

C 13.44:77

**NBS MONOGRAPH 77**

**Sound Insulation of Wall,  
Floor, and Door Constructions**

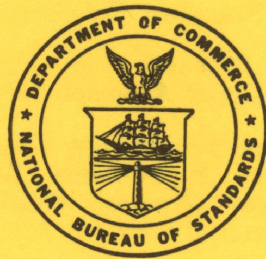

**U.S. DEPARTMENT OF COMMERCE  
NATIONAL BUREAU OF STANDARDS**

UNIVERSITY OF  
ARIZONA LIBRARY  
Documents Collection  
JAN 11 1965

## THE NATIONAL BUREAU OF STANDARDS

The National Bureau of Standards is a principal focal point in the Federal Government for assuring maximum application of the physical and engineering sciences to the advancement of technology in industry and commerce. Its responsibilities include development and maintenance of the national standards of measurement, and the provisions of means for making measurements consistent with those standards; determination of physical constants and properties of materials; development of methods for testing materials, mechanisms, and structures, and making such tests as may be necessary, particularly for government agencies; cooperation in the establishment of standard practices for incorporation in codes and specifications; advisory service to government agencies on scientific and technical problems; invention and development of devices to serve special needs of the Government; assistance to industry, business, and consumers in the development and acceptance of commercial standards and simplified trade practice recommendations; administration of programs in cooperation with United States business groups and standards organizations for the development of international standards of practice; and maintenance of a clearinghouse for the collection and dissemination of scientific, technical, and engineering information. The scope of the Bureau's activities is suggested in the following listing of its four Institutes and their organizational units.

**Institute for Basic Standards.** Electricity. Metrology. Heat. Radiation Physics. Mechanics. Applied Mathematics. Atomic Physics. Physical Chemistry. Laboratory Astrophysics.\* Radio Standards Laboratory: Radio Standards Physics; Radio Standards Engineering.\*\* Office of Standard Reference Data.

**Institute for Materials Research.** Analytical Chemistry. Polymers. Metallurgy. Inorganic Materials. Reactor Radiations. Cryogenics.\*\* Office of Standard Reference Materials.

**Central Radio Propagation Laboratory.\*\*** Ionosphere Research and Propagation. Troposphere and Space Telecommunications. Radio Systems. Upper Atmosphere and Space Physics.

**Institute for Applied Technology.** Textiles and Apparel Technology Center. Building Research. Industrial Equipment. Information Technology. Performance Test Development. Instrumentation. Transport Systems. Office of Technical Services. Office of Weights and Measures. Office of Engineering Standards. Office of Industrial Services.

---

\*NBS Group, Joint Institute for Laboratory Astrophysics at the University of Colorado.  
\*\*Located at Boulder, Colorado.

UNITED STATES DEPARTMENT OF COMMERCE • Luther H. Hodges, *Secretary*  
NATIONAL BUREAU OF STANDARDS • A. V. Astin, *Director*

# Sound Insulation of Wall, Floor, and Door Constructions

Raymond D. Berendt and George E. Winzer

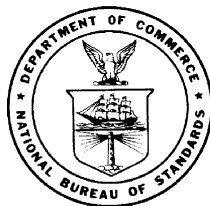

National Bureau of Standards Monograph 77  
Consolidated Supplement to Building Materials and Structures Report 144  
(Supersedes Supplements 1 and 2 of BMS Report 144)

Issued November 30, 1964

**Library of Congress Catalog Card Number: 64-60044**

## Foreword

The increasing concentration of dwellings in urban areas, along with the current trend toward lightweight structures, has recently placed emphasis upon noise control problems in multifamily dwellings. To erect buildings with good sound insulation, architects and builders need to know the acoustic properties of various building materials and structures. This publication, containing acoustical test results on over 100 building constructions, was prepared to meet their needs.

The National Bureau of Standards has investigated the sound insulating properties of building structures for many years and continues to strive toward improvement of the measuring techniques employed in these investigations.

In 1939, the Bureau's first summary report on sound insulation of building structures was published as NBS Building Materials and Structures Report 17, *Sound Insulation of Wall and Floor Constructions*. Supplements to BMS 17, were issued in 1940 and 1947. These earlier publications were superseded by BMS 144, *Sound Insulation of Wall and Floor Constructions* (1955), to which supplements were issued in 1956 and 1958.

The present Monograph supersedes the first and second supplements to BMS 144. It includes all the information contained in these supplements as well as additional data obtained through January 1964. New single-figure ratings are given for airborne sound transmission (STC) and impact sound transmission (INR). Octave-frequency band spectra of impact noise are included as additional information.

A. V. ASTIN, *Director*.



## Contents

	Page
1. Introduction.....	1
2. Measurement of sound transmission loss.....	1
3. Discussion of the single-figure ratings of airborne sound insulation...	2
4. Sound transmission class (STC).....	2
5. Measurement of impact sound pressure levels.....	2
6. Discussion of single-figure ratings of impact sound insulation.....	4
7. Impact noise ratings (INR).....	4

### LIST OF TABLES

1. Airborne sound transmission loss—doors.....	7
1-A. Airborne sound transmission loss—miscellaneous structures.....	17
2. Airborne sound transmission loss—walls.....	25
3. Sound transmission loss and impact sound pressure levels of floor-ceiling constructions.....	37
Index I. Numerical index of test panels.....	44
Index II. Sound transmission class index of test panels	
A. Doors.....	45
B. Walls.....	46
C. Floor-ceiling constructions.....	48
D. Miscellaneous structures.....	48
Index III. Impact noise rating index of floor-ceiling constructions.....	49
Appendix: Conversion of units to international system units.....	48





# Sound Insulation of Wall, Floor, and Door Constructions

Raymond D. Berendt and George E. Winzer

The data obtained at the National Bureau of Standards on the sound insulating properties of building structures are summarized. The results of the two previous Supplements to BMS Report 144 (1955) are included, together with later results obtained through January 1964. Single figure ratings, STC and INR, for airborne sound transmission and impact sound transmission, respectively, as well as the octave frequency band spectra of impact noise, are included as additional information. A brief description of the sound-measuring techniques is given.

## 1. Introduction

Building Materials and Structures Report 144,<sup>1</sup> issued February 1955, and its two supplements, issued in February 1956 and December 1958 respectively, included the results of sound insulation measurements made at the National Bureau of Standards through December 1957. This Monograph is designed to supersede Supplements 1 and 2 by including all the information contained in them as well as all results obtained in the period January 1958 through January 1964.

In recent years, the increasing severity of the noise control problem in multifamily dwellings has placed an emphasis upon impact sound insulation. Therefore, the octave band analyses of impact sound pressure level measurements (ISPL) are included in the results reported in this publication. In addition, the Sound Transmission Class<sup>2</sup> (STC) values have been included as a guide to classification of the sound insulation of walls, floors, and doors.

The authors express their sincere appreciation to the members of the Sound Section Staff, past and present, who performed the measurements cited here, and to the members of the section's Mechanical Support Group who produced the drawings of the test specimens.

Special thanks are due to Gary R. Kahler, who checked the data, and to David R. DeAngelis, whose drawings have greatly added to the clarity of the descriptions contained herein. The cooperation of Mrs. LaHoma Cloeren, who typed the manuscript, is sincerely appreciated.

## 2. Measurement of Sound Transmission Loss

Measurements are made in accordance with ASTM E90-61T.<sup>2</sup>

Figure 1 shows the test rooms in which most of the results contained in this report were obtained. Rooms A, B, and C are reverberant rooms which

have volumes of approximately 1213, 1691, and 1631 cubic feet, respectively. Wall test panels, usually built into a 2×8-in. wood frame with outside dimensions of 71×88 in., are installed in the test opening between rooms A and B. Floor-ceiling test panels of the same size are installed in the test opening between rooms C and A.

The method of test employs an interchange of source and receiving rooms, wherein first the A room is the source room and the B room the receiving room, and then vice versa. The results of the two tests are averaged. The sound source consists of four boxed loudspeakers placed in the lower trihedral corners of the room. In each room, six microphones, selectively placed at distances no less than one-quarter wavelength for the lowest test frequency from all reflecting surfaces, space-average the sound pressure levels which are automatically recorded by a sound level recorder.

The eleven test frequencies used are 125, 175, 250, 350, 500, 700, 1000, 1500, 2000, 3000, and 4000 hertz (Hz).<sup>\*</sup> The test signals are frequency modulated at a rate of 8 times per second to give bands of frequencies; approximate bandwidths are

<sup>\*</sup>One hertz=one cycle per second. This new symbol was adopted by the Eleventh General Conference on Weights and Measures, Paris, October 11-20, 1960.

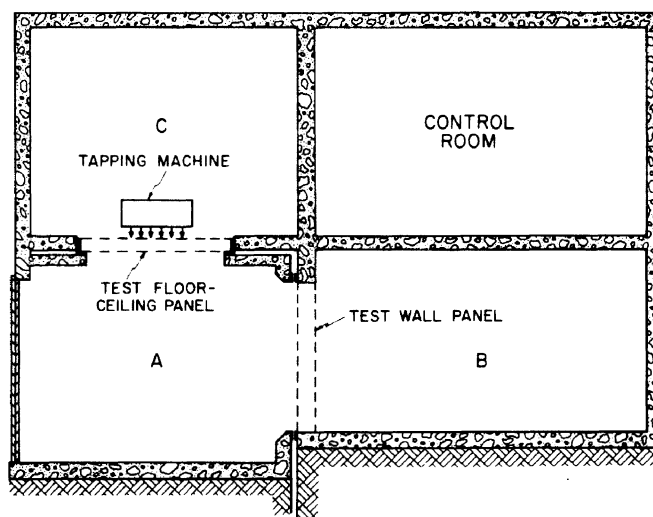

FIGURE 1. Vertical section of NBS sound transmission facilities.

<sup>1</sup> For sale by the Superintendent of Documents, U.S. Government Printing Office, Washington, D.C., 20402. Price, 40 cents.

<sup>2</sup> American Society for Testing and Materials "Tentative Recommended Practice for Laboratory Measurement of Airborne Sound Transmission Loss of Building Floors and Walls." ASTM Designation: E90-61T, issued 1961.

as follows:  $\pm 20$  percent of the nominal test frequency at 125 Hz,  $\pm 15$  percent at 175 Hz,  $\pm 13$  percent at 350 Hz,  $\pm 7$  percent at 3000 Hz,  $\pm 5$  percent at 4000 Hz, and  $\pm 10$  percent at the other frequencies. The signal received is filtered to improve the signal-to-noise ratio. The sound transmission loss (STL) is defined by the expression:<sup>3</sup>

$$\text{STL} = L_1 - L_2 + 10 \log_{10} \left( \frac{S}{A_2} \right) \text{ in decibels,}$$

where:

$L_1$  = time-space average sound pressure level in the source room,

$L_2$  = time-space average sound pressure level in the receiving room,

$S$  = area of sound transmitting surface of the test specimen,

$A_2$  = total absorption of the receiving room, in sabins.

### 3. Discussion of the Single-Figure Ratings of Airborne Sound Insulation

Since the beginning of investigations of the acoustic properties of architectural structures, several methods have been proposed and employed to classify such structures by means of a single-value rating as to their sound insulating properties. These ratings have all been based upon the physical measurements of STL at various frequencies.

The nine-frequency arithmetic average was reported in BMS Report 144 (1955), and in the interim, we have used single-figure ratings, such as the eleven-frequency arithmetic average and the energy average. These early ratings have been superseded by the sound transmission class (STC) in the present publication. It is commonly acknowledged that a single figure classification does serve a useful purpose in categorizing structures with similar sound insulation properties. *It should be emphasized that the sound transmission loss spectra should be studied in order to choose the proper construction to meet the sound insulation requirements of a particular installation.*

The sound transmission class, which is based on a minimum performance concept patterned after European rating systems, makes an attempt to rank-order panels with some regard to insulation from annoying frequencies. Since the methods of obtaining the various single figures differ, *caution must be exercised to avoid using different single figure classification values interchangeably; i.e., a test panel whose arithmetic or energy average is 45 dB will not necessarily have an STC of 45; more than likely it will differ.* If comparison of present results with earlier results

is desired, sufficient data are reported to enable one to readily obtain any of the other averages.

### 4. Sound Transmission Class (STC)<sup>4</sup>

In this classification system a test specimen is rated by comparing its sound transmission losses at the eleven test frequencies with the sound transmission class contours. STC contours may be constructed on conventional semi-logarithmic paper as follows:<sup>5</sup> a horizontal line segment from 1400 to 4000 Hz, at a sound transmission loss value corresponding to the sound transmission class; a middle line segment decreasing 6 dB in the interval 1400 to 350 Hz; a low-frequency segment decreasing 14 dB in the interval 350 to 125 Hz (see fig. 2). The sound transmission class for the specimen corresponds to the higher STC contour (to the nearest decibel) that fits the sound transmission loss measurements according to the following rules:

(1) The sound transmission loss values must be on or above the STC contour in the frequency range 350 to 1400 Hz.

(2) An average deviation of 1 dB or less is permitted in each of the frequency ranges below 350 and above 1400 Hz; (in calculating the average deviation in these ranges, points lying above the contour are assumed to lie on the contour).

Three examples are given in figure 2; the STC of Curve A is 50 as determined by the STL at 175 Hz; the STC of Curve B is 40 as determined by the STL at 500 Hz; and the STC of Curve C is 30 as determined by the STL values at 2000 and 3000 Hz. The foregoing examples illustrate the use of the rules for determining the STC, and also point up the advantage of having a single figure which drastically reduces the number of sound transmission loss spectra which have to be examined in order to choose a construction which will meet specific sound insulation requirements.

The STC values (indicated by \*) in the tables for panels 608-629, 237-238, 313-319, 438, and 711-712 were obtained from measurements at nine rather than eleven frequencies and should be regarded with caution since it is difficult to predict the behavior of test specimens at 1500 and 3000 Hz without actual measurements.

### 5. Measurement of Impact Sound Pressure Levels

The assessment of impact sound transmission through a floor-ceiling structure begins with the measurement of the sound pressure levels in the room below, which are generated by a standard tapping machine in operation on the test floor (see fig. 1).

Impact sound pressure level measurements are made in accordance with the ISO Recommenda-

<sup>3</sup> E. Buckingham, "Theory and Interpretation of Experiments on the Transmission of Sound through Partition Walls," BS Sci. Pap. #0, 193-219 (1925) 8506.

<sup>4</sup> ASTM E90-61T; A4., p. 1131.

<sup>5</sup> ASTM E90-61T; Note 2., p. 1131.

FIGURE 2. Sound Transmission Class (STC) contours with three typical spectra illustrating use of STC rating.

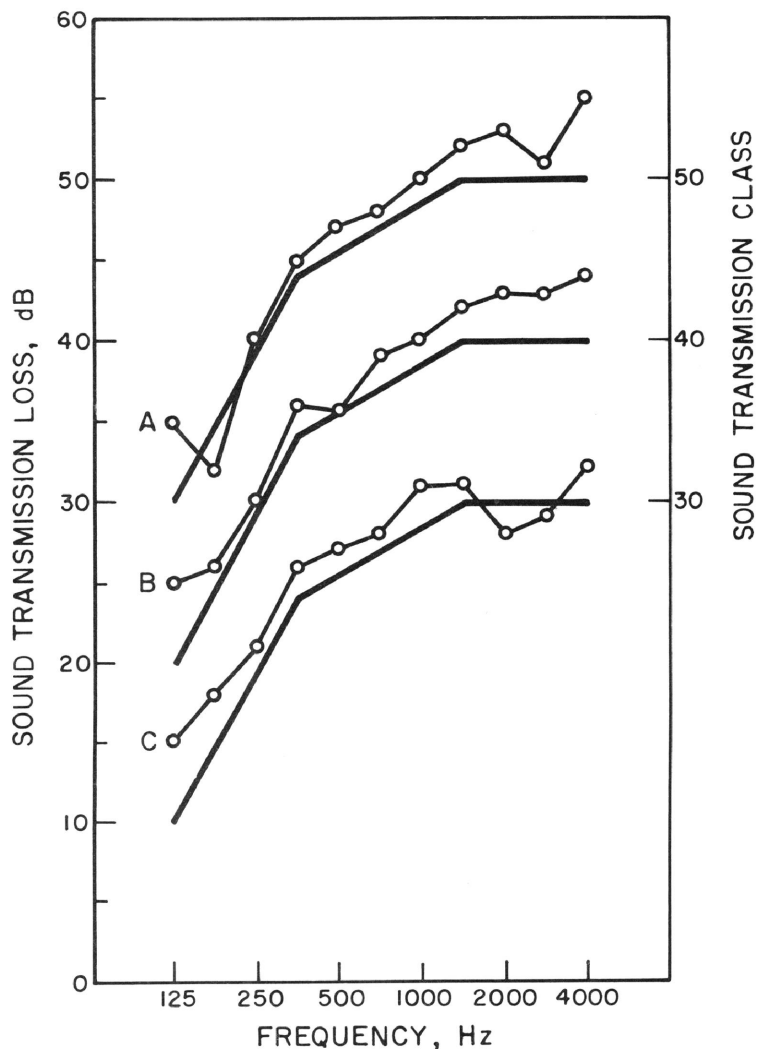

tion R140-1960 (E).<sup>6</sup> The impact sound is generated by a tapping machine, figure 3, placed successively in at least three positions on the test floor. For floors which are nonhomogeneous, the tapping machine position is carefully specified; e.g., for joist constructions the machine is placed with the line of hammers striking (a) between joists, (b) on a joist, and (c) across a joist with only the center hammer striking on the joist.

The tapping machine is constructed in accordance with the cited specification, as follows:

(a) Five hammers placed in a line, with the center to center distance of the two end hammers about 40 cm.

(b) The time between successive impacts should be  $100 \pm 5$  msec.

(c) The effective mass of each hammer should be 0.5 kg (within 2.5 percent).

(d) The drop of the hammer on a flat floor should be equivalent to a free drop without friction of 4 cm (within 2.5 percent).

(e) The part of the hammer which strikes the floor should be a cylinder of brass or steel, 3 cm

in diameter, with a spherical surface having a radius of about 50 cm.

(f) The hammer should strike the floor only

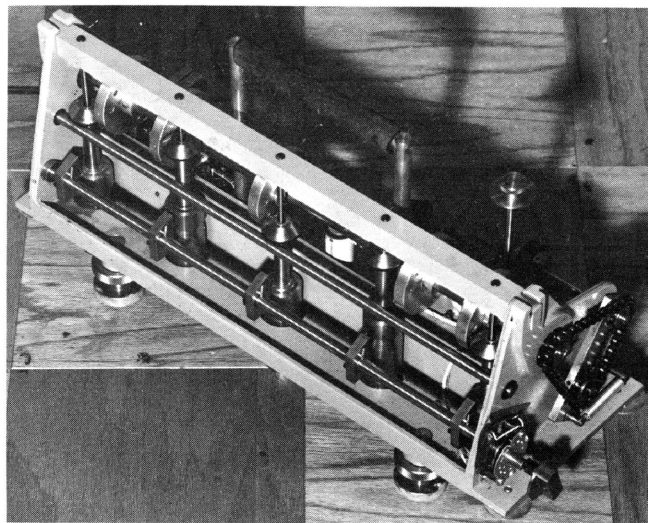

FIGURE 3. Tapping machine used for generating sound field for impact sound transmission measurements.

The five 0.5 kg hammers fall 4 cm to the floor and produce 10 impacts per second.

<sup>6</sup> International Organization for Standardization Recommendation R140, "Field and Laboratory Measurements of Airborne and Impact Sound Transmission," 1st ed., Jan. 1960.

once each time it is released and should always fall through an effective height of 4 cm.

(g) In the case of a fragile floor covering, hammers should be used which have the striking part coated with a layer of rubber, of which the dimensions, composition and vulcanization are specified.<sup>7</sup>

The space average sound pressure levels in the room below the floor-ceiling test panel are determined in octave wide frequency bands from 75 to 4800 Hz, with a reference sound pressure of 0.0002 dyne/cm<sup>2</sup>, and are adjusted to a reference absorption of  $A_0 = 10 \text{ m}^2$  or 107.6 ft<sup>2</sup> by the addition of

$$10 \log_{10} \left( \frac{A}{107.6} \right)$$

to the measured levels, where  $A$  is the absorption in the receiving room expressed in sabins.

## 6. Discussion of Single-Figure Ratings of Impact Sound Insulation

Impact test results presented as *tapping loss* in BMS Report 144, were obtained by a method

<sup>7</sup> International Organization for Standardization Recommendation R140, "Field and Laboratory Measurements of Airborne and Impact Sound Transmission," 1st ed., Jan. 1960.

which depended upon the sound pressure level in the room containing the tapping machine. That method of measurement has been superseded by the method described in the preceding section. The differences in the methods of measuring the *impact sound pressure levels* and the *tapping loss* are such that the conversion of numerical values from one to the other is not feasible.

In this Monograph, a computed overall value (OA), which is the sum total of the energy contributions of each frequency band, is reported. In addition, an impact noise rating (INR) is reported as will be described in the next section.

## 7. Impact Noise Ratings (INR)

The Federal Housing Administration has published a guide to impact noise control in multifamily dwellings.<sup>8</sup> The guide contains a curve of the recommended maximum impact sound pressure levels (ISPL) as measured in the room below floor-ceiling constructions, and a single figure impact noise rating (INR) indicating the degree

<sup>8</sup> "Impact Noise Control in Multifamily Dwellings," FHA No. 750, for sale by the Superintendent of Documents, U.S. Government Printing Office, Washington, D.C., 20402, price 50 cents.

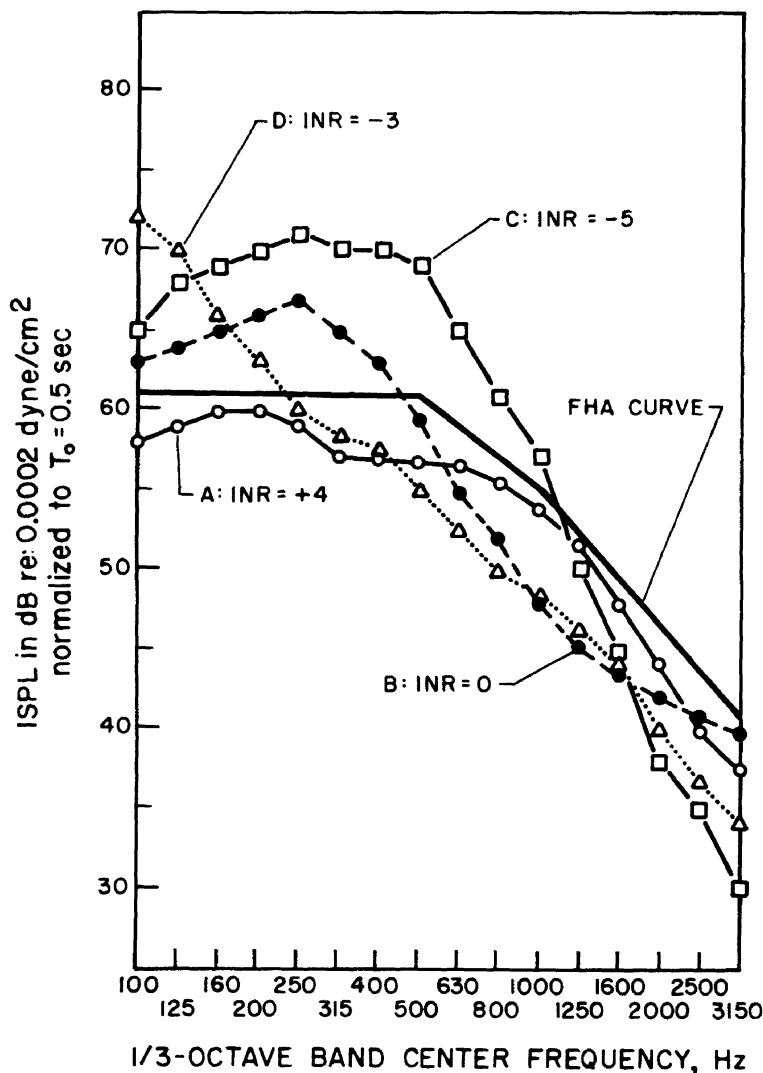

FIGURE 4. FHA Recommendation Curve with the measured impact sound pressure levels (ISPL) of four typical constructions and their single figure impact noise rating (INR).

[FHA curve should be raised 5 dB for use with octave-band data.]

of acceptance or nonacceptance, as well as descriptions and data of many constructions. Figure 4 shows the FHA Recommendation Curve along with the measured ISPL values of four typical constructions and their INR ratings.

In accordance with these recommendations, acceptability of a construction would be determined by the following rules:

(1) The measured ISPL curve may not exceed the recommended curve by more than 8 dB at any frequency.

(2) The mean deviation in the unfavorable sense may not exceed 2 dB as averaged over the sixteen 1/3-octave bands between 100 and 3150 Hz.

The impact noise rating (INR) may be determined by moving the FHA curve up or down until the measured ISPL curve meets the above requirements. To further illustrate these points, consider construction "A" in figure 4; it obviously meets the recommendation, and in fact, the FHA curve may be shifted downward 4 dB without exceeding the allowable deviation; thus the construction is given an INR=+4. Construction "B" meets the recommendation with a mean excess ISPL of less than 2 dB and does not exceed 8 dB at any frequency, hence an INR=0. Construction "C" has a mean excess ISPL (reading

from left to right) of

$$\frac{4+7+8+9+10+9+9+8+6+4+2}{16} = \frac{76}{16} = 4.75 \text{ dB}$$

and the construction fails on several counts—(1) the ISPL exceeds 8 dB at several frequencies and (2) the mean deviation is greater than 2 dB. However, if the FHA recommended curve were moved 5 dB upward, the measured ISPL would be within the tolerances, and the structure rates INR=-5. The measured ISPL of construction "D" exceeds the FHA curve by more than 8 dB at some frequencies, and consequently is given an INR=-3.

Since the measured sound pressure levels are a function of the absorption of the receiving room, the data in the tables are normalized to a reference absorption of  $A_0=10 \text{ m}^2$  or  $107.6 \text{ ft}^2$ .

In the FHA No. 750 Guide, the data are normalized to a reference reverberation time  $T_0=0.5$  sec. The distinction between the two normalization methods becomes significant with large departures from a receiving room volume of  $1100 \text{ ft}^3$ ; however, the laboratory test results reported in this Monograph were obtained in a  $1200 \text{ ft}^3$  room, in which case the two normalization methods yield results agreeing within 0.5 dB.

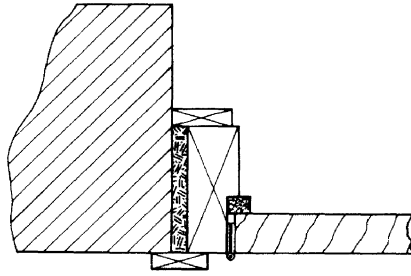

PANEL 616

PANEL 616. 3- by 30- by 84-in. solid wooden door; sponge rubber gaskets, approximately  $\frac{1}{2}$  by  $\frac{1}{2}$  in., around sides and top of door jamb; sponge rubber drop closure was installed in bottom of door.

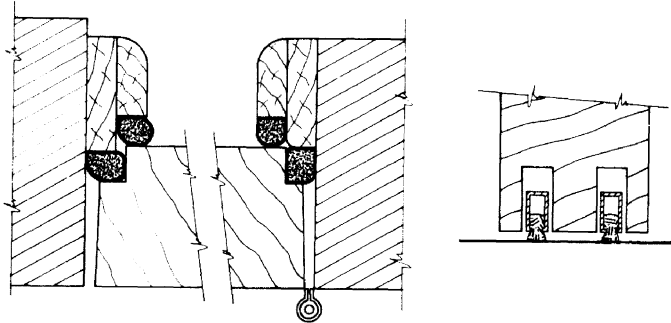

PANEL 617

- PANEL 617.  $2\frac{1}{2}$ - by 36- by 84-in. solid wooden door; 2 felt drop closures installed in bottom of door; two cylindrical foam rubber gaskets  $\frac{1}{2}$ -in. diam, covered with a plasticized fabric, mounted on door jamb, provided a double seal along top and sides.
- PANEL 618.  $2\frac{1}{2}$ - by 36- by 84-in. wooden door with  $25\frac{3}{8}$ - by  $70\frac{3}{8}$ -in. panels set into  $\frac{1}{4}$ -in. resilient rubber which separated the panels from the door frame (similar to panel 620). Gaskets and drop closures similar to those used with panel 617.
- PANEL 619.  $1\frac{3}{4}$ - by 36- by 84-in. wooden door similar to panel 620. Rectangular sponge rubber gaskets  $\frac{3}{4}$  by  $\frac{9}{16}$  in. on door stops,  $\frac{3}{4}$ -in. surface making contact with the door, provided seal at top and sides; sponge rubber drop closure was installed in bottom of the door.

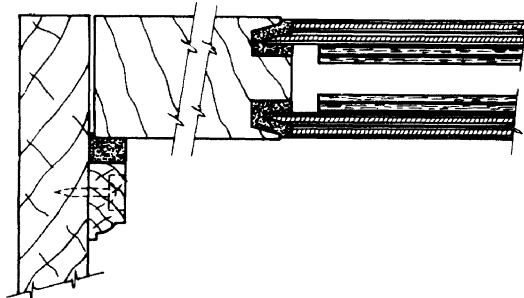

PANEL 620

- PANEL 620.  $2\frac{1}{2}$ - by 36- by 84-in. wooden door with  $\frac{1}{2}$ - by  $25\frac{3}{8}$ - by  $70\frac{3}{8}$ -in. plywood panels set into  $\frac{1}{4}$ -in. resilient rubber which separated the panels from the door frame. The plywood panels were backed with a laminated layer of damping material. The seals and drop closure were similar to those used with panel 619.
- PANEL 621. 3- by 36- by 84-in. wooden door similar to panel 620. Rectangular hard rubber gaskets used instead of sponge rubber on doorstops. A sponge rubber drop closure was installed in bottom of door.
- PANEL 622. Same as panel 621, except cracks between the door and doorjamb were completely sealed around the four edges on the side opposite the gaskets with a soft clay caulking compound.
- PANEL 623. Same as panel 621, except the hard rubber gaskets were replaced by soft sponge rubber gaskets.

TABLE 1. Airborne Sound Transmission Loss—DOORS

Panel No.	Airborne sound transmission loss (in dB) at frequencies (Hz)												Weight lb/ft <sup>2</sup>
	125	175	250	350	500	700	1000	1500	2000	3000	4000	STC	
616.....	31	27	32	30	33	31	29		37		41	*30	7.0
617.....	28	31	27	22	28	27	28		34		32	*28	5.6
618.....	27	32	33	31	36	35	32		39		34	*33	6.8
619.....	28	36	31	30	32	31	32		37		37	*33	4.3
620.....	26	31	30	30	33	32	29		36		38	*30	6.8
621.....	30	38	34	33	40	36	34		43		42	*35	7.3
622.....	32	40	35	38	44	44	46		49		55	*44	7.3
623.....	30	38	36	35	41	38	37		45		46	*38	7.3

\*STC based upon nine test frequencies.

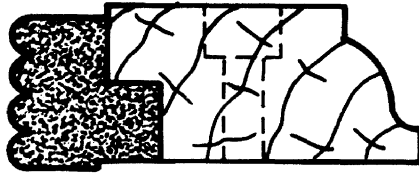

PANEL 624

- PANEL 624. 3- by 36- by 84-in. wooden door similar to panel 621, except the gasket was corrugated sponge rubber and glued to the doorstep with a lap joint, as illustrated. A sponge rubber drop closure was installed in bottom of door.
- PANEL 625. 2½- by 36- by 84-in. wooden door similar to panel 620, with same type gaskets as those used with panel 624. A sponge rubber drop closure was installed in bottom of door. **The door was completely sealed around the edges on both sides with a soft clay caulking compound.**
- PANEL 626. 1¼- by 36- by 84-in. wooden door similar to panel 625, including gaskets and drop closure. **The door was completely sealed around the edges on both sides with a soft clay caulking compound.**

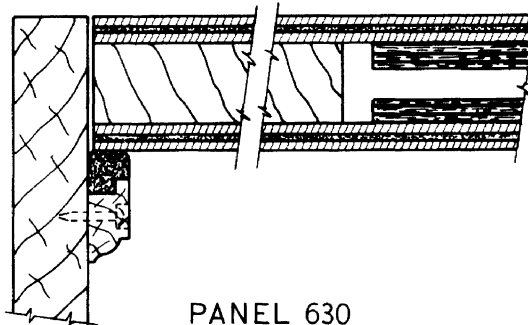

PANEL 630

- PANEL 630. 2½- by 36- by 84-in. wooden door with a 1½-in.-thick core; on each side, ½-in. seven-ply panels with ⅛-in. sponge rubber centers; panels backed with laminated layer of damping material. Corrugated sponge rubber gaskets similar to those of panel 624 were used, and a sponge rubber drop closure was installed in bottom of the door. **The door was completely sealed around the edges on the side opposite the gaskets with a soft clay caulking compound.**

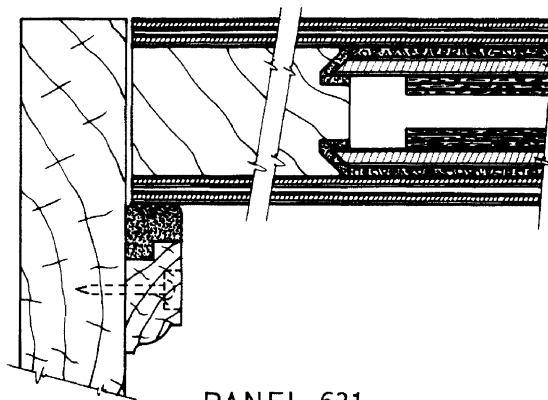

PANEL 631

- PANEL 631. 2½- by 36- by 84-in. wooden door with a 1¾-in. core; on each side, ¼-in. panels installed in rubber gaskets and recessed ⅛ in. below face of core; panels backed with laminated layer of damping material; ⅜-in. plywood panels applied to both sides of core assembly, with ⅛-in. cork between inner and outer panels. Corrugated sponge rubber gaskets on doorstops, such as with panel 624, and a sponge rubber drop closure were used. **The edges of the door on side opposite gasket were completely sealed with a soft clay caulking compound.**
- PANEL 632. 1¼- by 36- by 84-in. wooden door with a solid core. Corrugated sponge rubber gaskets on doorstops, similar to panel 624, and a sponge rubber drop closure were used. **The edges of the door on side opposite gasket were completely sealed with a soft clay caulking compound.**
- PANEL 633. 1¼- by 36- by 84-in., veneer face flush type, wooden door with hollow core installed in conventional manner, i.e., ¼-in. airspace at bottom, no drop closure, and no gaskets on ⅜-in. wooden doorstep.
- PANEL 634. Same door as panel 633, except all edges on side opposite doorstops were completely sealed with a soft clay caulking compound.

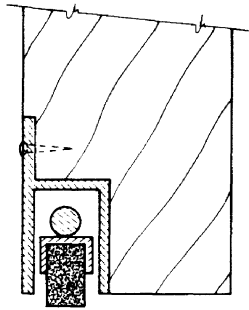

TABLE 1. Airborne Sound Transmission Loss—DOORS—Continued

Panel No.	Airborne sound transmission loss (in dB) at frequencies (Hz)												Weight lb/ft <sup>3</sup>
	125	175	250	350	500	700	1000	1500	2000	3000	4000	STC	
624.....	28	32	34	34	38	38	37	-----	42	-----	43	*38	7.3
625.....	25	32	36	35	38	39	43	-----	48	-----	54	*41	6.8
626.....	28	30	31	30	31	29	32	-----	39	-----	45	*32	4.3
630.....	32	33	36	36	37	34	34	36	38	35	38	35	7.7
631.....	35	32	36	24	36	36	39	44	43	38	40	30	8.2
632.....	30	34	30	29	30	28	29	33	38	41	44	30	4.6
633.....	14	18	19	17	23	17	18	18	17	16	21	18	1.9
634.....	19	22	22	19	24	19	19	20	20	21	29	20	1.9

\*STC based upon nine test frequencies.

- PANEL 635. 2½- by 36- by 84-in. wooden door similar to panel 631, except ⅛-in. cork layer omitted between inner and outer panels. Door mounted in conventional manner, i.e., ¼-in. airspace at bottom, no drop closure, and no gaskets on wooden doorstops.
- PANEL 636. Same as panel 635, except corrugated sponge rubber gaskets were applied to doorstops, and the edges on side opposite gaskets were sealed with a soft clay caulking compound at the top and two sides; ¼-in. airspace at bottom.



PANEL 637

- PANEL 637. Same as panel 636, except a sponge rubber drop closure was installed in bottom of door.
- PANEL 638. Same as panel 637, except all four edges on side opposite gaskets were sealed with a soft clay caulking compound.

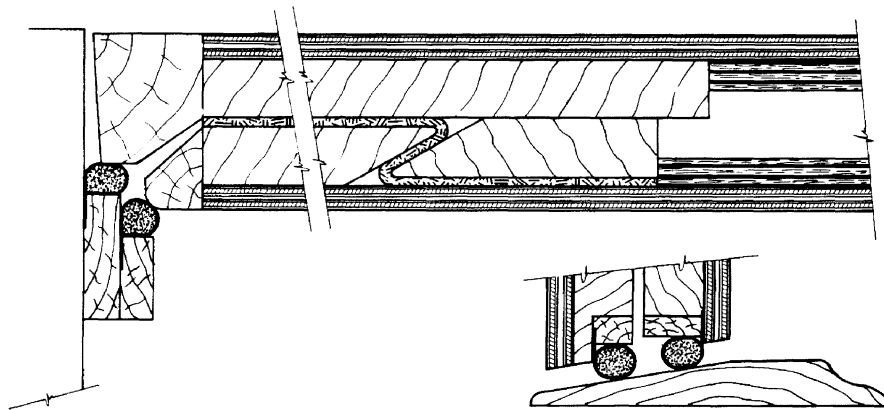

PANEL 639

- PANEL 639. 2½- by 36- by 84-in. wooden door of double construction with two interlocking frames separated by ½-in.-thick felt sheet; a viscous damping material applied to inner panel faces. Two cylindrical foam rubber gaskets, ⅝-in. diam, covered with a plasticized fabric, provided a double seal along top and sides; similar gaskets closed onto a tapered wooden threshold to provide seal at bottom.

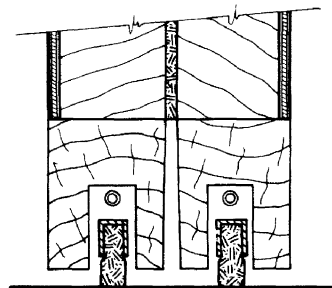

PANEL 640

- PANEL 640. 2½- by 36- by 84-in. wooden door similar to panel 639, except seals at bottom were replaced with two felt drop closures which closed onto a flat wooden threshold, as shown.
- PANEL 641. 4- by 36- by 84-in. wooden door; construction and seals similar to panel 640.
- PANEL 642. Same as panel 641, except door was completely sealed on both sides with plaster.

TABLE 1. Airborne Sound Transmission Loss—DOORS—Continued

Panel No.	Airborne sound transmission loss (in dB) at frequencies (Hz)												Weight lb/ft <sup>2</sup>
	125	175	250	350	500	700	1000	1500	2000	3000	4000	STC	
635.....	26	26	24	20	27	26	25	24	26	24	22	24	7.8
636.....	27	26	30	25	31	29	30	31	31	26	24	26	7.8
637.....	31	29	30	26	36	34	35	38	38	36	38	32	7.8
638.....	31	30	32	24	38	35	36	36	40	37	38	30	7.8
639.....	31	30	35	29	36	34	36	39	44	47	48	35	7.3
640.....	34	30	35	30	32	32	33	36	42	42	38	34	6.6
641.....	34	32	37	36	39	43	42	45	51	53	53	42	12.3
642.....	39	37	41	40	45	47	50	54	56	58	62	46	12.3

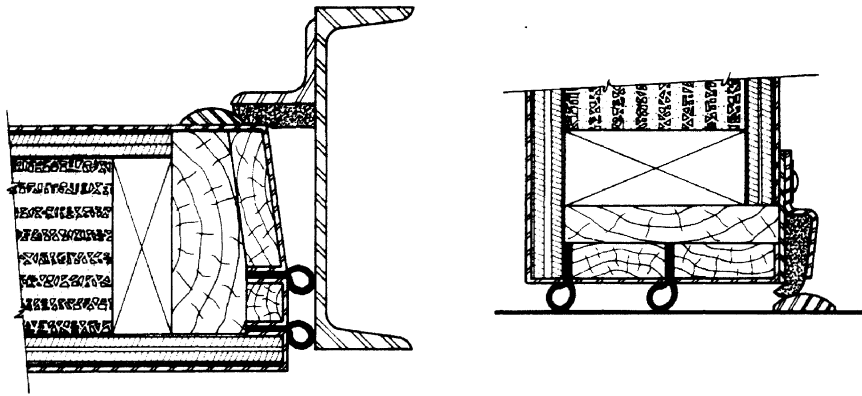

PANEL 643

PANEL 643.  $5\frac{3}{4}$ - by 56- by  $73\frac{3}{4}$ -in. metal-clad door. Front panel consists of  $\frac{3}{4}$ -in. plywood,  $\frac{1}{16}$ -in. asbestos paper, and 16 gage steel; back panel has  $\frac{3}{8}$ -in. plywood, a layer of damping material, and 16 gage steel; cork fill in 4-in. space between panels. Half-oval molding at top and sides of door closed against a  $\frac{1}{4}$ - by 2- by 2-in. steel angle lined with  $\frac{3}{8}$ -in. neoprene foam rubber gasket; two neoprene tubular gaskets attached to door helped to provide seal around all four edges; in addition, at the bottom of the door a  $\frac{3}{8}$ - by 2-in. neoprene foam rubber gasket closed against a half-oval metal threshold.

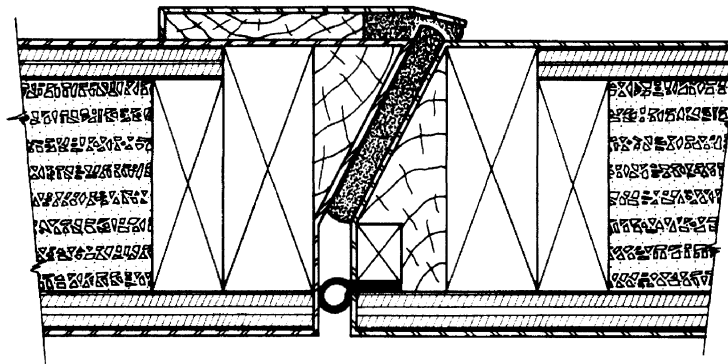

PANEL 644

PANEL 644. Metal-clad double door,  $5\frac{3}{4}$  by  $55\frac{1}{2}$  by  $73\frac{3}{4}$  in. overall; door construction and seals similar to panel 643, except the two tubular gaskets at bottom were replaced by a  $\frac{3}{8}$ -in.-thick foam rubber drop closure. The seal between the two doors was provided by a neoprene tubular gasket and a  $\frac{3}{8}$ - by 4-in. neoprene foam rubber gasket; a  $\frac{3}{8}$ - by 2-in. neoprene foam rubber gasket attached to overlapping flange sealed joint.

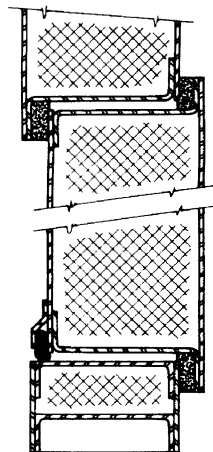

PANEL 645

PANEL 645.  $4\frac{1}{4}$ - by  $29\frac{1}{2}$ - by  $77\frac{1}{2}$ -in. door with unperforated sheet metal faces, mounted in a metal frame; void between faces filled with sound-absorptive material. Frame flanged with  $\frac{1}{16}$ - by  $1\frac{1}{16}$ -in. sponge rubber gaskets around top and sides; door similarly flanged with rubber around four edges; additional seal at bottom provided by  $\frac{1}{2}$ -in. solid rubber strip, held by an adjustable retainer, closing onto a metal threshold.

TABLE 1. Airborne Sound Transmission Loss—DOORS—Continued

Panel No.	Airborne sound transmission loss (in dB) at frequencies (Hz)												Weight lb/ft <sup>2</sup>
	125	175	250	350	500	700	1000	1500	2000	3000	4000	STC	
643.....	41	35	40	43	49	50	52	54	57	60	64	49	23.8
644.....	36	32	41	44	48	52	53	54	56	58	61	50	30.7
645.....	33	30	31	28	31	31	33	38	38	42	42	34	13.0

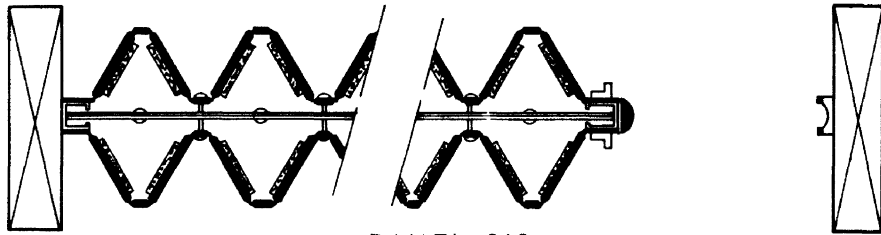

PANEL 646

PANEL 646. 60- by 74-in. accordion-type folding door. On each side, 20 vertical panels, forming 10 pleats, made of five-ply laminated material, i.e., outside ply of vinyl, three composition board core plys, and inner ply of impregnated sheeting; panels held on vertical steel pantographs. Liners of  $\frac{1}{8}$ -in. composition board covered with thin felt attached inside of panels. Rubber sweep strips attached to external covers at top and bottom on both sides, and a half-round rubber bumper on vertical edge, which closed into two  $\frac{1}{4}$ -in. sponge rubber strips on frame molding, sealed the door.

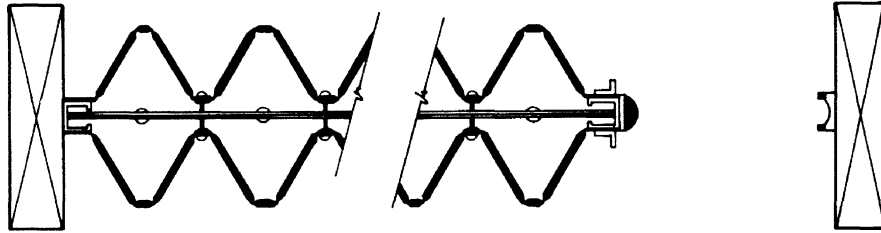

PANEL 646-A

PANEL 646-A. Same as panel 646 except the liners were removed, as well as the sweep strips at top and bottom on one side only.

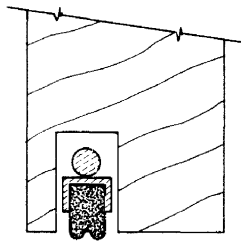

PANEL 651

PANEL 651.  $2\frac{1}{2}$ - by  $35\frac{3}{4}$ - by  $79\frac{1}{4}$ -in. wooden door with  $\frac{1}{2}$ - by  $25\frac{5}{8}$ - by  $66\frac{3}{4}$ -in. panels mounted in rubber similar to panel 620, p. 6. Seals similar to those illustrated with panel 624, p. 8. Sponge rubber drop closure installed in bottom of door; rubber was  $\frac{3}{4}$  in. high and  $\frac{5}{8}$  in. wide with a concave bottom surface.

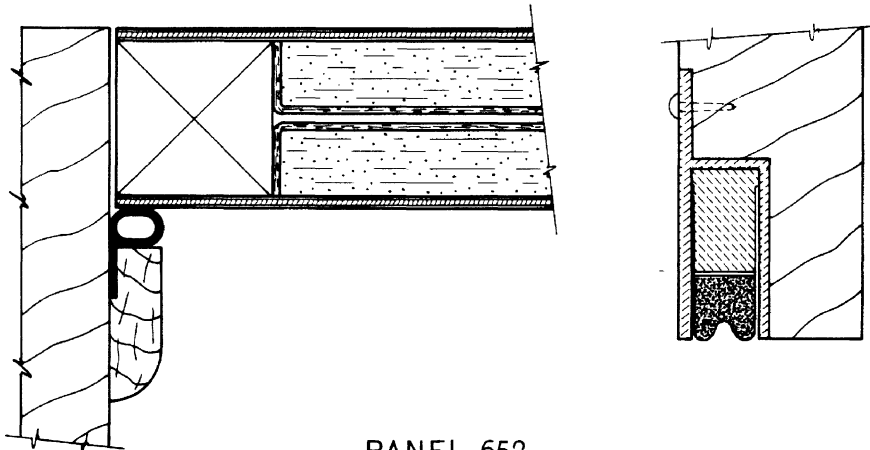

PANEL 652

PANEL 652.  $1\frac{3}{4}$ - by 36- by 84-in. door constructed of two panels held in a solid wooden frame; panels were  $\frac{5}{8}$ -in.-thick particle board composed of wood, silicates, and binder; density approximately 41.2 lb/ft<sup>3</sup>. The inner faces of the panels were coated with a bedding compound and  $\frac{1}{8}$ -in. felt building paper which extended around all four edges of each panel; approximately  $\frac{1}{16}$ -in. airspace between panels; the outer faces finished with  $\frac{1}{8}$ -in.-thick hardwood veneer. Tubular soft rubber gaskets,  $\frac{3}{32}$  in. thick and approximately  $\frac{1}{2}$  in. in diameter, stapled to  $\frac{1}{2}$ - by  $1\frac{1}{16}$ -in. wooden doorstops provided seal around top and sides; a sponge rubber drop closure with  $\frac{5}{8}$ -in. concave surface installed in bottom of door.

TABLE 1. *Airborne Sound Transmission Loss—DOORS—Continued*

Panel No.	Airborne sound transmission loss (in dB) at frequencies (Hz)												Weight lb/ft <sup>2</sup>
	125	175	250	350	500	700	1000	1500	2000	3000	4000	STC	
646.....	20	18	18	19	24	29	31	31	32	32	35	25	2.0
646-A.....	18	16	15	15	16	20	25	26	27	29	32	21	1.1
651.....	30	30	28	31	33	36	36	40	42	45	46	37	6.9
652.....	29	31	29	29	31	30	29	29	30	35	40	29	6.0

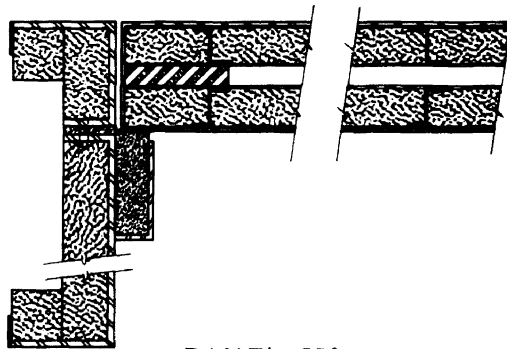

PANEL 653

PANEL 653. 2- by 36- by 84-in. metal door mounted in a 2- by 7½-in. "U" channel frame backed with 1-in.-thick fiberglass padding. The door was constructed of 18 gage sheet metal coated on the inside surfaces with an asphaltic compound and strengthened with vertical "Z" stiffening members, 7 in. on centers; ¼-in.-thick fiberglass insulation held by 24 gage perforated sheet metal liner on each side; ½-in. airspace between inner liners; ¾- by 2-in. asbestos strip at each edge. The door closed against soft sponge rubber gaskets, ¾- by 2-in., held by metal angle retainer at top and sides; two ¾- by ¾-in. sponge rubber drop closures installed in bottom of door.

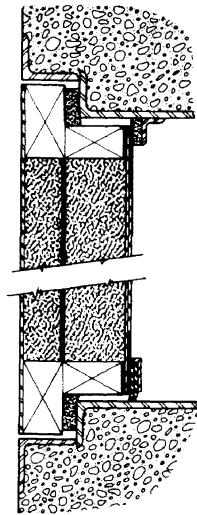

PANEL 654

PANEL 654. 6-in.-thick metal door with lapped closure, such that hinge side area was 45½ by 84½ in. and doorstop side area was 42 by 81 in., mounted in ¼- by 8-in. steel lap closure channel frame. The door was constructed of 18 gage metal sheets held by an inner wooden frame at the edges; 14 gage septum sheet placed between the two faces formed two chambers which contained mineral wool fill, density approximately 10.5 lb/ft³; ½-in.-thick felt liner along edges of one face separated it from the other face. The door closed against two vinyl-covered soft rubber gaskets mounted on lap closure at top and sides; inner gasket 1¾ by ¾ in., and outer gasket 1½ by ½ in.; bottom seal provided by a double layer of ⅛-in.-thick rubber held in an adjustable metal housing.

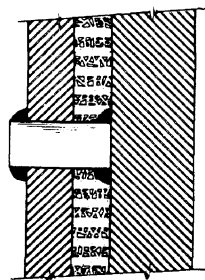

PANEL 608

PANEL 608. ⅝- and ⅜-in.-thick steel plates separated by ¼-in.-thick cork, under compression, in a panel with outside dimensions 59 by 77 by 1½ in.; ⅜-in.-diam steel studs penetrated ¼-in. cork and were welded to both steel plates; studs were placed approximately 12½ in. on centers vertically and 11¾ in. horizontally.

PANEL 609. Similar to panel 608, except the cork was replaced with an insulating material of polyvinyl acetate with cork granules, approximate density 0.6 lb/ft³.



TABLE 1. Airborne Sound Transmission Loss—DOORS—Continued

Panel No.	Airborne sound transmission loss (in dB) at frequencies (Hz)												Weight lb/ft <sup>2</sup>
	125	175	250	350	500	700	1000	1500	2000	3000	4000	STC	
653.....	36	36	39	40	35	36	38	36	37	43	44	36	8.4
654.....	36	37	43	44	50	48	46	52	57	61	61	47	23.0

TABLE 1-A. Airborne Sound Transmission Loss—MISCELLANEOUS STRUCTURES

Panel No.	Airborne sound transmission loss (in dB) at frequencies (Hz)												Weight lb/ft <sup>2</sup>
	125	175	250	350	500	700	1000	1500	2000	3000	4000	STC	
608.....	46	42	45	44	50	46	42	-----	48	-----	53	*43	36.7
609.....	46	42	45	44	48	48	46	-----	51	-----	55	*47	37.0

\*STC based upon nine test frequencies.

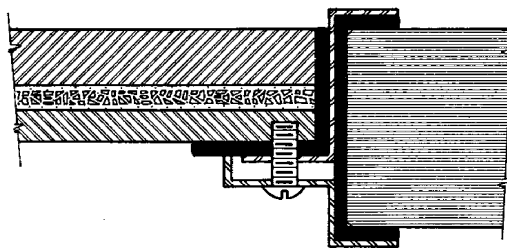

PANEL 610

PANEL 610. Similar to panel 608, except the outside dimensions of the panel were 71 by 89 in., and a 2- by 42- by 42-in. glass window was placed in the panel center. The window was mounted in rubber gaskets and held in place with a metal retaining frame screwed to the panel.

PANEL 611. Double-wall construction with a 4-in. airspace. One wall was panel 610 and the other wall consisted of  $\frac{1}{16}$ - and  $\frac{1}{16}$ -in.-thick steel plates separated by  $\frac{1}{4}$ -in.-thick cork, under compression, in a panel with outside dimensions of 59 by 77 in.; a 2- by 42- by 42-in. glass window was placed in the panel center, as in panel 610.

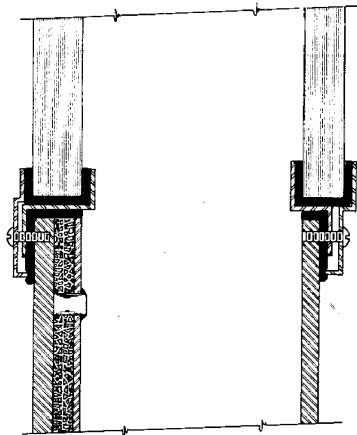

PANEL 614

PANEL 614. Double-wall construction with a 4-in. airspace. One wall consisted of  $\frac{1}{4}$ - by 59- by 77-in. steel plate with a  $\frac{5}{8}$ - by 42- by 42-in. glass window in the panel center. The other wall, with outside dimensions 71 by 89 in., consisted of  $\frac{5}{16}$ -in. and  $\frac{3}{32}$ -in. steel plates separated by  $\frac{5}{16}$ -in. insulating material of polyvinyl acetate with cork granules;  $\frac{3}{16}$ -in.-diameter studs, 12 in. on centers, penetrated the insulator and were welded to both plates a  $\frac{3}{4}$ - by 42- by 42-in. glass window was placed in the panel center. (Glass windows mounted as in panel 610.)

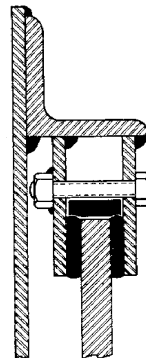

PANEL 615

PANEL 615. Double-wall construction with  $\frac{3}{4}$ -in. airspace. One wall consisted of a  $\frac{3}{16}$ -in. steel plate with  $1\frac{3}{4}$ - by  $1\frac{3}{4}$ - by  $\frac{1}{4}$ -in. angle welded to it. The other wall was a  $\frac{1}{16}$ -in. steel plate held in a channel, lined with  $\frac{1}{4}$ - by  $\frac{3}{4}$ -in. rubber under compression, formed by welding two pieces of steel 2 by  $\frac{3}{16}$ -in. to the angle.



PANEL 627

PANEL 627. Section of outer part of aircraft fuselage; 0.090-in.-thick aluminum alloy skin. The panel included some stiffening members not shown in drawing.

TABLE 1-A. Airborne Sound Transmission Loss—MISCELLANEOUS STRUCTURES—Continued

Panel No.	Airborne sound transmission loss (in dB) at frequencies (Hz)												Weight lb/ft <sup>2</sup>
	125	175	250	350	500	700	1000	1500	2000	3000	4000	STC	
610.....	44	40	42	44	45	45	47	-----	52	-----	55	*48	30.4
611.....	58	50	53	58	58	59	64	-----	64	-----	66	*62	57.3
614.....	54	51	50	56	55	58	60	-----	62	-----	67	*59	29.4
615.....	38	34	40	42	46	45	44	-----	51	-----	47	*45	29.3
627.....	22	16	14	18	24	23	23	-----	23	-----	23	*23	2.6

\*STC based upon nine test frequencies.

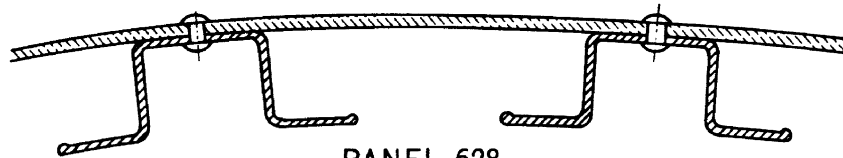

PANEL 628

PANEL 628. Section of outer part of aircraft fuselage; 0.090-in.-thick aluminum alloy skin. The panel included some stiffening members not shown in drawing.



PANEL 629

PANEL 629. Section of outer part of aircraft fuselage; outer skin 0.080-in.-thick and inner layer 0.063-in.-thick aluminum alloy. The panel included some stiffening members not shown in drawing.

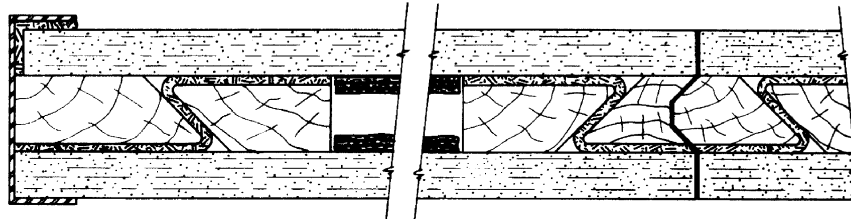

PANEL 647

PANEL 647. 2½-in.-thick movable partition composed of 36- by 88-in. tongue-and-groove panels set into a steel "U" channel frame ¼ in. thick, 2½ in. wide, and 1 in. deep. Each panel was constructed of two 1¼-in.-thick layers of particle board composed of wood, silicates, and binder, approximate density 41.2 lb/ft<sup>3</sup>, separated by a ½-in. airspace; both sides of particle board veneered with 1/28-in.-thick birch. The particle board layers were secured to an internal wooden frame of interlocking members separated by a ½-in.-thick layer of felt; also an "L"-shaped strip of ¼-in.-thick felt was attached to all four edges of one particle board layer; a laminated layer of damping material applied to inner faces adjoining the airspace. The "U" channel frame sealed in test opening with plaster.

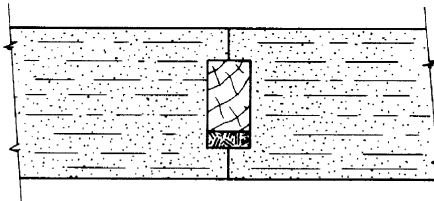

PANEL 648

PANEL 648. 1¾-in.-thick movable partition composed of 36- by 88½-in. panels. The panels were made of 1¾-in.-thick particle board composed of wood, silicates, and binder, approximate density 31.2 lb/ft<sup>3</sup>; the particle board panels were connected with a ½- by 1¼-in. wooden spline backed with a ¼- by ½-in. felt strip; the seam was caulked on both sides, and the edges sealed in test opening with plaster.

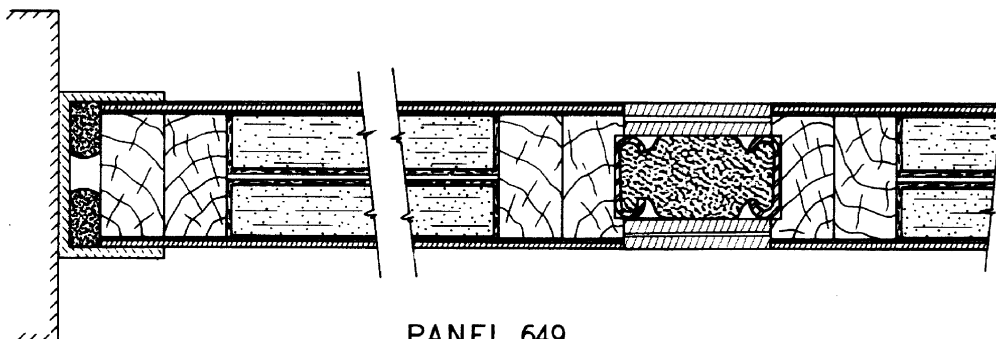

PANEL 649

PANEL 649. 1¾-in.-thick movable partition composed of 33¾- by 84-in. panels set into an aluminum "U" channel frame ½ in. thick, 2 in. wide, and 1¼ in. deep, lined with two ½- by ½-in. sponge rubber strips. Each panel was constructed of two layers of ½-in.-thick particle board, approximate density 41.2 lb/ft<sup>3</sup>, separated by 1/16-in. airspace; the opposing internal faces were coated with bedding compound and a 1/16-in.-thick layer of 55-lb felt building paper which extended around all four edges of the particle board layers. 1-in.-wide metal runners were screwed to inner edges of the panels and 1¼-in.-wide metal bridging strips, placed 15 in. on centers vertically, locked the panels together; the space between the runners was filled with mineral wool; ¾- by 1½- by 84-in. plywood strips, held to runners with spring clips, covered the joint. The bottom edges of the panels were supported by leveling screws leaving a 4-in. space which was filled with mineral wool and covered with ¾- by 5-in. plastic base plates screwed to external faces of partition.

TABLE 1-A. *Airborne Sound Transmission Loss*—MISCELLANEOUS STRUCTURES—Continued

Panel No.	Airborne sound transmission loss (in dB) at frequencies (Hz)												Weight lb/ft <sup>3</sup>
	125	175	250	350	500	700	1000	1500	2000	3000	4000	STC	
628.....	23	17	15	20	19	18	23		24		26	*21	2.6
629.....	23	17	13	20	25	22	24		29		27	*25	2.5
647.....	28	25	31	31	35	34	34	32	37	45	52	32	7.4
648.....	25	25	24	26	26	26	24	24	28	31	34	24	4.0
649.....	30	27	28	31	33	36	32	33	35	41	46	33	6.0

\*STC based upon nine test frequencies.

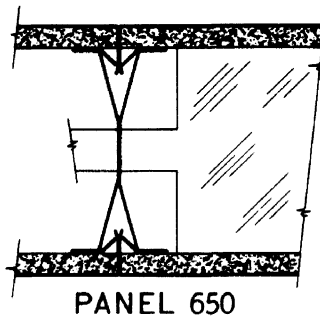

PANEL 650

PANEL 650. 3-in.-thick movable partition consisting of 2½-in. metal studs placed 24 in. on centers and braced with horizontal metal bridging members, approximately 20 in. apart. 24- by 79-in. #20 gage steel panels backed with ¼-in.-thick insulation board snap-fitted to the studs; each side of the partition was finished with a ¾-in. metal cornice section at the top; the 5½-in. airspace at the bottom covered on both sides with 6-in.-wide base sections clipped to the stud bases. The perimeter edges of the partition were sealed on both sides with a soft clay caulking compound.

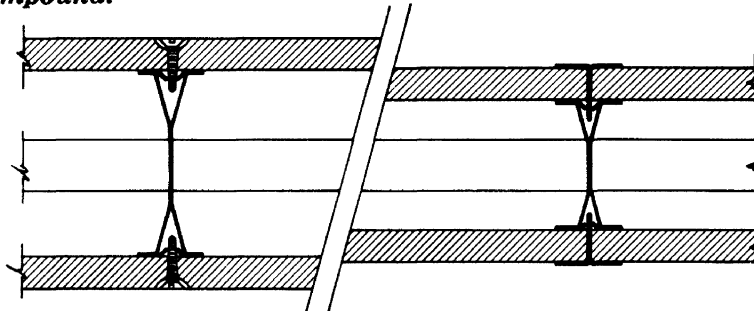

PANEL 655

PANEL 656

PANEL 655. 4⅛-in.-thick movable partition consisting of 3½-in. metal studs placed 24 in. on centers and braced with horizontal metal bridging members, approximately 24 in. on centers. On each side, ⅝- by 48- by 84-in. gypsum wallboard panels screwed, 8 in. on centers, to studs; all joints taped and finished. The partition was finished with 2-in.-wide metal cornices at the ceiling edge.

PANEL 656. 3¾-in.-thick movable partition similar to panel 655 except 2½-in. metal studs were used, and ⅝- by 24- by 84-in. gypsum wallboard panels were attached to the studs with 1¼-in.-wide metal "T" bar batten strips. Both sides of the partition were finished with 2-in.-wide metal cornices at the ceiling edge and 6-in.-wide metal base cover plates.

PANEL 657. 3-in.-thick movable partition similar to panel 656 except the gypsum wallboard was replaced with ¼- by 24- by 79-in. asbestos-cement board panels; the 5-in. airspace at the bottom was covered by 6-in. base cover plates.

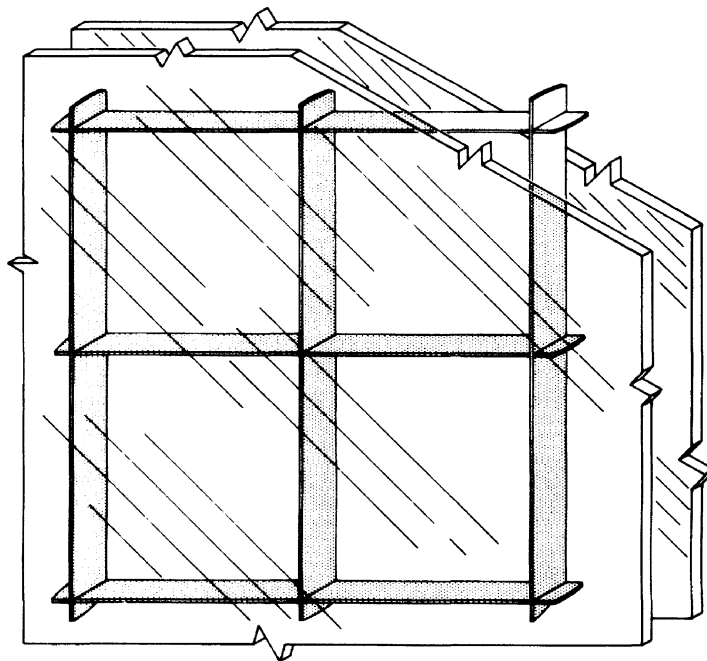

PANEL 658

PANEL 658. 3⅛-in.-thick partition of "shadow-box" construction consisting of ⅛- by 2¼-in. aluminum framing with ⅛-in.-thick transparent plastic panels bonded to both sides.

TABLE 1-A. Airborne Sound Transmission Loss—MISCELLANEOUS STRUCTURES—Continued

Panel No.	Airborne sound transmission loss (in dB) at frequencies (Hz)												Weight lb/ft <sup>2</sup>
	125	175	250	350	500	700	1000	1500	2000	3000	4000	STC	
650.....	21	25	31	37	43	48	50	51	51	54	58	41	4.6
655.....	25	30	27	30	34	37	39	39	36	37	41	36	6.1
656.....	24	28	26	28	32	38	42	43	36	37	42	34	6.4
657.....	22	24	18	20	24	33	35	30	31	29	31	26	5.8
658.....	14	18	25	28	28	33	40	43	46	49	51	32	2.9

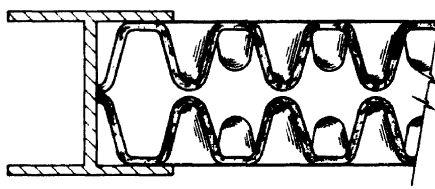

PANEL 250

PANEL 250.  $1\frac{3}{4}$ - by 23- by 23-in. hollow plastic panels with  $\frac{1}{32}$ -in.-thick skin, supported and joined with 2-in. aluminum and hardboard "H" beams; each panel surface contained 800 horn-shaped depressions of two sizes arranged in alternating rows  $1\frac{1}{8}$  in. on centers, one size depression tapered in diameter from  $\frac{1}{4}$  in. to  $\frac{1}{8}$  in. with a depth of  $\frac{1}{4}$  in., and the other tapered in diameter from  $\frac{1}{2}$  in. to  $\frac{1}{16}$  in. with a depth of  $\frac{1}{2}$  in.

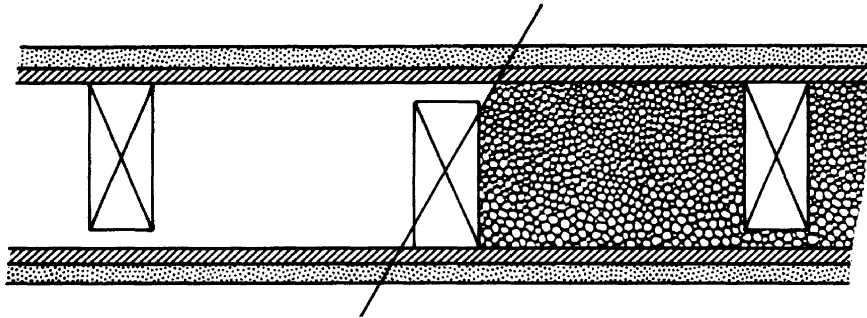

PANEL 237

PANEL 238

PANEL 237. Staggered 2- by 4-in. wood studs, each set 16 in. on centers and spaced 8 in. on centers with  $\frac{1}{2}$  in. offset from the other set. On each side  $\frac{3}{8}$ -in. plain gypsum lath nailed to studs,  $\frac{1}{2}$ -in. gypsum vermiculite plaster, machine-applied, and a hand-applied white-coat finish.

PANEL 238. Same as panel 237 except space between studs contained vermiculite fill. Density of fill was 6.3 lb/ft<sup>3</sup>.

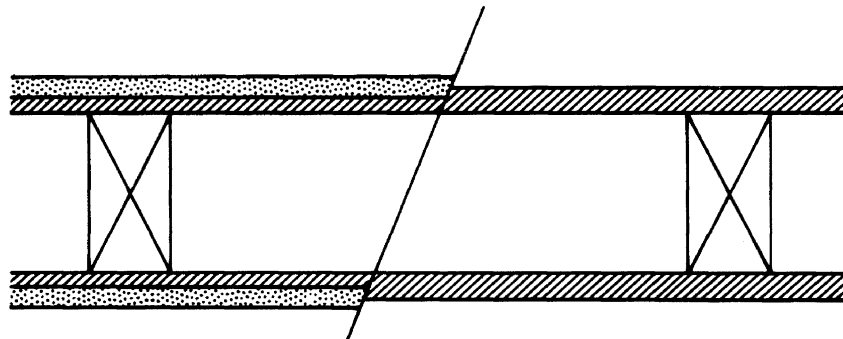

PANEL 239

PANEL 240

PANEL 239. 2- by 4-in. wood studs 16 in. on centers;  $\frac{3}{8}$ -in. perforated gypsum lath nailed to studs,  $\frac{1}{2}$ -in. sanded gypsum plaster with white-coat finish.

PANEL 240. 2- by 4-in. wood studs 16 in. on centers;  $\frac{5}{8}$ -in. tapered-edge gypsum wallboard nailed 7 in. on centers; joints taped and finished.

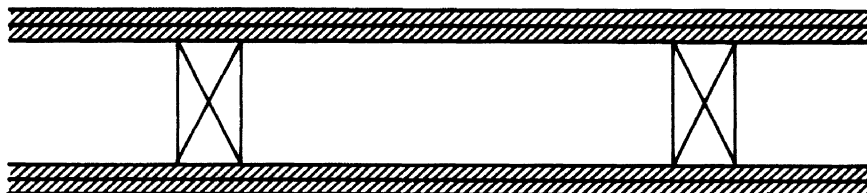

PANEL 241

PANEL 241. 2- by 4-in. wood studs 16 in. on centers; two layers of  $\frac{5}{8}$ -in. tapered-edge gypsum wallboard, first layer nailed 7 in. on centers and second layer 14 in. on centers; joints taped and finished.



TABLE 1-A. Airborne Sound Transmission Loss—MISCELLANEOUS STRUCTURES—Continued

Panel No.	Airborne sound transmission loss (in dB) at frequencies (Hz)												Weight lb/ft <sup>2</sup>
	125	175	250	350	500	700	1000	1500	2000	3000	4000	STC	
250.....	20	18	16	19	24	26	32	36	32	28	29	25	1.7

TABLE 2. Airborne Sound Transmission Loss—WALLS

Panel No.	Airborne sound transmission loss (in dB) at frequencies (Hz)												Weight lb/ft <sup>2</sup>
	125	175	250	350	500	700	1000	1500	2000	3000	4000	STC	
237.....	36	37	33	39	42	40	42	-----	41	-----	51	*43	11.1
238.....	37	37	37	42	49	49	50	-----	52	-----	66	*48	12.8
239.....	42	34	32	38	42	47	49	46	50	58	62	44	14.2
240.....	30	22	31	30	37	39	44	43	39	45	52	36	7.2
241.....	33	28	30	36	37	40	45	42	44	50	57	41	12.9

\*STC based upon nine test frequencies.

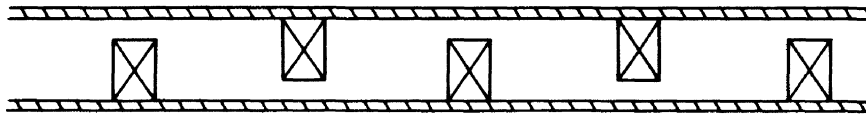

PANEL 242

- PANEL 242. 2- by 3-in. wood studs 16 in. on centers, staggered;  $\frac{1}{2}$ -in. tapered-edge gypsum wallboard nailed 7 in. on centers; joints taped and finished.
- PANEL 243. 2- by 3-in. wood studs 16 in. on centers, staggered;  $\frac{1}{8}$ -in. tapered-edge gypsum wallboard nailed 7 in. on centers; joints taped and finished.

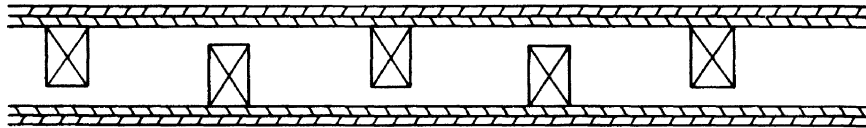

PANEL 244

- PANEL 244. 2- by 3-in. wood studs 16 in. on centers, staggered; two layers of  $\frac{1}{8}$ -in. tapered-edge gypsum wallboard, first layer nailed 7 in. on centers and second layer 16 in. on centers; joints taped and finished.

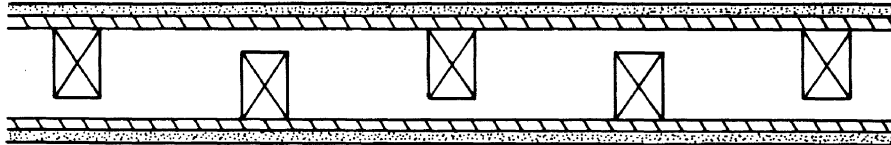

PANEL 245

- PANEL 245. 2- by 3-in. wood studs 16 in. on centers, staggered;  $\frac{1}{8}$ - by 16- by 48-in. perforated gypsum lath,  $\frac{1}{2}$ -in. sanded gypsum plaster including white-coat finish.

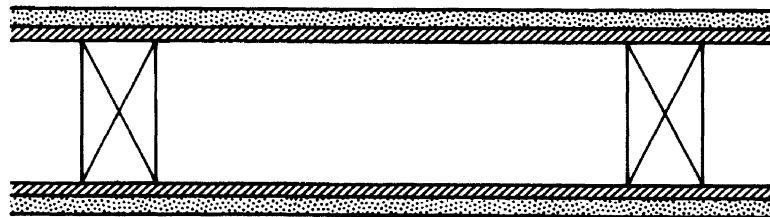

PANEL 251

- PANEL 251. 2- by 4-in. wood studs 16 in. on centers,  $\frac{1}{8}$ -in. plain gypsum lath nailed to studs,  $\frac{1}{2}$ -in. sanded gypsum plaster with white-coat finish.

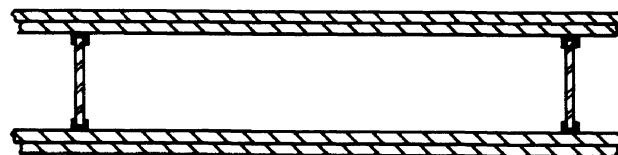

PANEL 247

- PANEL 247.  $\frac{3}{4}$ -in. steel studs, 16 in. on centers, attached to top and bottom by stud shoes, starter clips, and stud tracks; gypsum wallboard (backer board)  $\frac{1}{8}$ - by 24-in. clipped to studs with galvanized wire clips; edges of wallboard held together by galvanized steel clips [see "D" clip, p. 44 of BMS Report 144];  $\frac{1}{8}$ - by 48-in. gypsum wallboard laminated to the inner layer with joint cement.

TABLE 2. *Airborne Sound Transmission Loss—WALLS—Continued*

Panel No.	Airborne sound transmission loss (in dB) at frequencies (Hz)												Weight lb/ft <sup>2</sup>
	125	175	250	350	500	700	1000	1500	2000	3000	4000	STC	
242.....	36	31	36	40	40	46	47	50	52	41	45	44	6.2
243.....	43	44	37	38	40	46	48	47	41	44	50	44	7.7
244.....	41	41	41	43	46	48	49	45	41	49	54	44	13.4
245.....	48	48	46	47	48	47	48	43	48	55	59	43	15.6
251.....	30	34	42	41	40	44	48	39	39	44	51	39	13.4
247.....	35	34	39	43	44	49	50	51	50	47	51	48	7.5

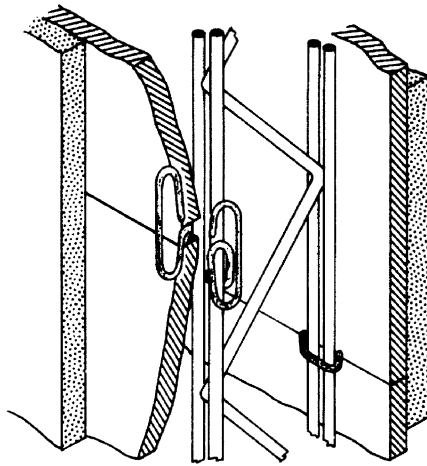

PANEL 438

PANEL 438.  $2\frac{1}{2}$ - by  $\frac{1}{2}$ -in. steel studs placed 16 in. on centers with stud shoes wire-tied to steel runners. Galvanized wire clips attached to studs on both sides, held  $\frac{3}{8}$ -in. plain gypsum lath, joined with sheet metal clips,  $\frac{1}{16}$ -in. gypsum vermiculite plaster, and  $\frac{1}{16}$ -in. white-coat finish. (Sheet metal clip similar to "D" clip, p. 44 of BMS Report 144.)

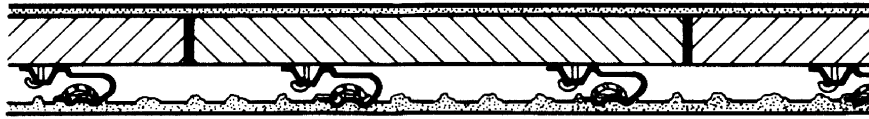

PANEL 313

PANEL 313. 3- by 12- by 30-in. hollow gypsum blocks cemented together,  $\frac{1}{2}$ -in. mortar joints. On one side  $\frac{1}{16}$ -in. sanded gypsum plaster; on the other side resilient clips, spaced 18 in. on centers vertically and 16 in. on centers horizontally, held  $\frac{3}{4}$ -in. metal channels 16 in. on centers, to which expanded metal lath was wire-tied;  $\frac{1}{16}$ -in. sanded gypsum plaster.  $\frac{1}{16}$ -in. white-coat finish applied to both sides. (Clip similar to one illustrated with panel 428, p. 22 of BMS Report 144.)

PANEL 317. Similar to panel 313, except 4- by 12- by 30-in. gypsum blocks were used.

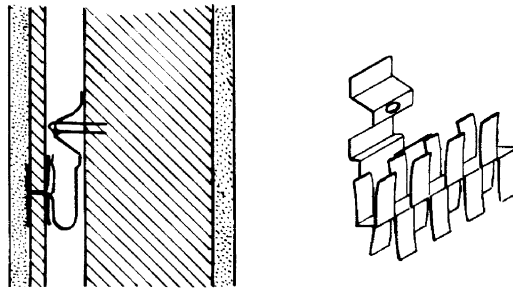

PANEL 314

PANEL 314. 3- by 12- by 30-in. hollow gypsum blocks cemented together,  $\frac{1}{2}$ -in. mortar joints. On one side  $\frac{1}{16}$ -in. sanded gypsum plaster; on the other side resilient clips, attached with 2-in. staples 16 in. on centers both vertically and horizontally,  $\frac{3}{8}$ -in. plain gypsum lath and  $\frac{1}{16}$ -in. sanded gypsum plaster;  $\frac{1}{16}$ -in. white-coat finish applied to both sides.

PANEL 318. Similar to panel 314, except 4- by 12- by 30-in. gypsum blocks were used.

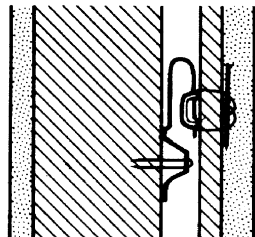

PANEL 315

PANEL 315. 3- by 12- by 30-in. hollow gypsum blocks cemented together,  $\frac{1}{2}$ -in. mortar joints. On one side  $\frac{1}{16}$ -in. sanded gypsum plaster; on the other side resilient clips, attached with 2-in. staples placed 24 in. on centers horizontally and  $28\frac{1}{4}$  in. on centers vertically, held  $\frac{3}{4}$ -in. horizontal metal channels wire-tied  $28\frac{1}{4}$  in. on centers to clips,  $\frac{1}{2}$ -in. "V" edge long-length gypsum lath wire-tied to channels, and  $\frac{1}{16}$ -in. sanded gypsum plaster;  $\frac{1}{16}$ -in. white-coat finish applied to both sides. (Clip similar to one illustrated with Panel 428, p. 22 of BMS Report 144.)

TABLE 2. Airborne Sound Transmission Loss—WALLS—Continued

Panel No.	Airborne sound transmission loss (in dB) at frequencies (Hz)												Weight lb/ft <sup>2</sup>
	125	175	250	350	500	700	1000	1500	2000	3000	4000	STC	
438.....	27	26	28	32	39	41	44		38		49	*38	9
313.....	38	40	37	40	44	48	51		56		59	*46	27
317.....	45	44	44	47	50	53	55		56		59	*53	31
314.....	42	41	43	46	48	51	53		56		60	*52	24
318.....	43	41	42	46	52	52	56		55		61	*52	26
315.....	48	43	41	43	47	48	44		55		62	*45	27

\*STC based upon nine test frequencies.

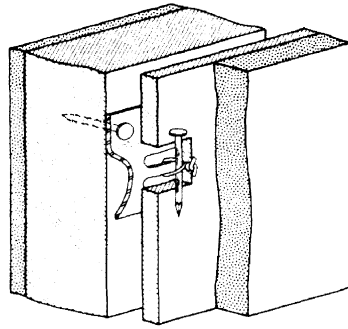

PANEL 316

PANEL 316. 3- by 12- by 30-in. hollow gypsum blocks cemented together,  $\frac{1}{2}$ -in. mortar joints. On one side  $\frac{1}{16}$ -in. sanded gypsum plaster; on the other side slotted resilient metal furring runners placed 25 in. on centers, nailed to mortar joints 12 in. on centers,  $\frac{1}{2}$ -in. long-length gypsum lath wire-tied to the runners, and  $1\frac{1}{16}$ -in. of sanded gypsum plaster;  $\frac{1}{16}$ -in. white-coat finish applied to both sides.

PANEL 319. Similar to panel 316, except 4- by 12- by 30-in. gypsum blocks were used.

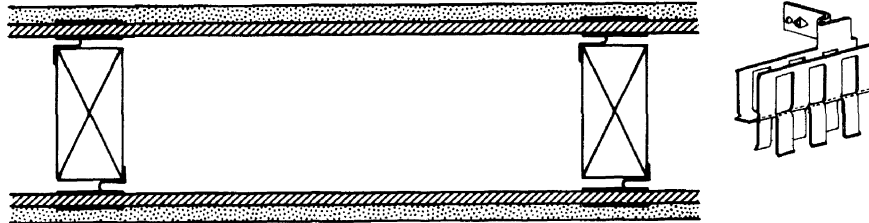

PANEL 439

PANEL 439. 2- by 4-in. wood studs 16 in. on centers; sheet metal resilient clips, nailed to studs on both sides, held  $\frac{3}{8}$ -in. gypsum lath,  $\frac{1}{16}$ -in. sanded gypsum plaster, and  $\frac{1}{16}$ -in. white-coat finish.

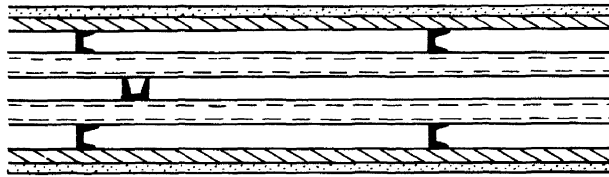

PANEL 440

PANEL 440. Five layers of  $\frac{3}{4}$ -in. cold-rolled steel channel, wire-tied together, formed core of panel. The center layer consisted of two pieces of channel 2 in. long placed vertically 40 in. apart and wire-tied between two horizontal lengths of channel. Vertical channels 16 in. on centers were wire-tied to the horizontal channels;  $\frac{3}{8}$ -in. plain gypsum lath, 16 in. wide, was wire-tied to vertical channels, with lath joints held by sheet metal clips;  $\frac{1}{2}$ -in. sanded gypsum plaster with white-coat finish applied to both sides. (See "D" clip illustration on p. 44 of BMS Report 144.)

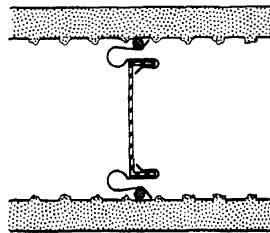

PANEL 441

PANEL 441. 2 $\frac{3}{4}$ -in. steel trusses, 16 in. on centers; on each side resilient clips fastened to studs 16 in. on centers,  $\frac{1}{4}$ -in. metal rod wire-tied to clips, and metal lath wire-tied to metal rods.  $\frac{3}{4}$ -in. sanded gypsum plaster, including white-coat finish, applied to both sides. (Similar to panel 429, p. 50 of BMS Report 144.)

PANEL 442. 2- by 4-in. wood studs placed 16 in. on centers. On each side resilient clips, nailed to studs, held  $\frac{3}{8}$ -in. plain gypsum lath,  $\frac{1}{16}$ -in. sanded gypsum plaster, and  $\frac{1}{16}$ -in. white-coat finish. (Similar to panel 439, above.)

TABLE 2. Airborne Sound Transmission Loss—WALLS—Continued

Panel No.	Airborne sound transmission loss (in dB) at frequencies (Hz)												Weight lb/ft <sup>3</sup>
	125	175	250	350	500	700	1000	1500	2000	3000	4000	STC	
316.....	41	40	40	43	46	44	46		58		61	*47	26
319.....	41	41	40	43	49	49	49		57		62	*49	26
439.....	43	38	41	47	48	48	50	44	42	51	56	44	14.4
440.....	46	42	44	48	54	55	55	48	50	57	62	48	13.5
441.....	49	48	49	51	53	56	59	53	58	63	63	53	18.6
442.....	47	47	46	45	52	55	55	44	42	52	57	44	12.4

\*STC based upon nine test frequencies.

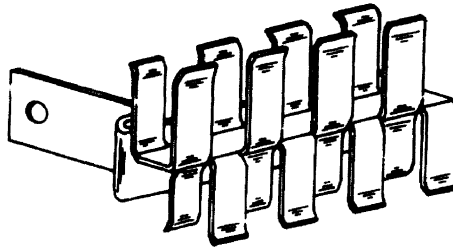

PANEL 443

PANEL 443. Similar to panel 442 with different resilient clips, as illustrated.

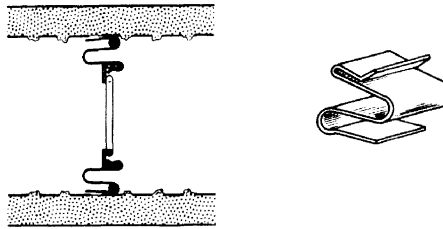

PANEL 444

PANEL 444.  $2\frac{1}{2}$ -in. steel studs held 16 in. on centers by stud tracks and stud shoes at top and bottom. On each side, resilient clips held  $\frac{1}{4}$ -in.-diameter pencil rods with 3.4 lb/ft<sup>2</sup> diamond-mesh metal lath wire-tied to rods,  $\frac{1}{16}$ -in. sanded gypsum plaster, and  $\frac{1}{16}$ -in. white-coat finish.

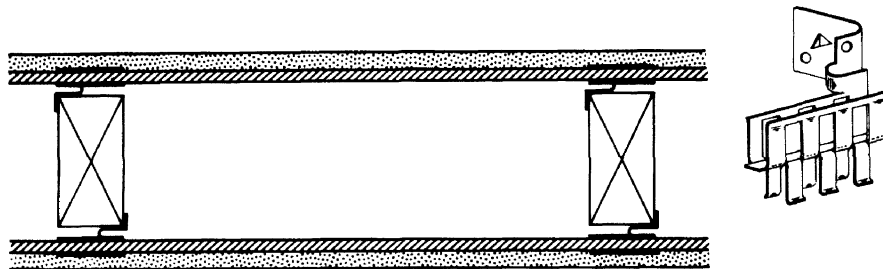

PANEL 445

PANEL 445. 2- by 4-in. wooden studs, 16 in. on centers, with resilient clips nailed to both sides. The clips held  $\frac{3}{8}$ - by 24-in. gypsum backer board, mounted horizontally with opposing joints staggered, and  $\frac{1}{2}$ -in. wallboard laminated to backer board with joint cement; all joints taped and finished.

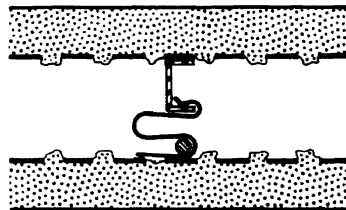

PANEL 446

PANEL 446.  $\frac{3}{4}$ -in. steel channel studs spaced 16 in. on centers. On one side resilient clips, attached 16 in. on centers to studs, held  $\frac{1}{4}$ -in.-diameter pencil rods with 3.4 lb/ft<sup>2</sup> diamond-mesh metal lath wire-tied to rods. On the other side, the metal lath was wire-tied directly to the steel channel studs.  $\frac{1}{16}$ -in. sanded gypsum plaster and  $\frac{1}{16}$ -in. white-coat finish applied to both sides.

PANEL 447.  $1\frac{1}{8}$ - by  $\frac{1}{2}$ -in. steel studs held 16 in. on centers top and bottom by metal tracks; studs held  $\frac{3}{8}$ -in. gypsum backer board with sheet metal clips joining the edges.  $\frac{1}{2}$ -in. gypsum wallboard was laminated to the backer board with joint cement, and all joints were taped and finished. A sheet metal base,  $2\frac{1}{2}$  in. wide, was attached to the bottom on both sides. (Clips and studs similar to those illustrated with panel 438, p. 28.)



TABLE 2. Airborne Sound Transmission Loss—WALLS—Continued

Panel No.	Airborne sound transmission loss (in dB) at frequencies (Hz)												Weight lb/ft <sup>2</sup>
	125	175	250	350	500	700	1000	1500	2000	3000	4000	STC	
443.....	46	46	44	46	52	55	57	46	43	51	60	46	12.5
444.....	45	43	47	49	51	51	48	41	48	54	60	41	21.7
445.....	39	36	41	47	48	52	53	55	53	49	54	52	9.3
446.....	32	32	40	41	46	47	44	36	42	46	51	36	18.9
447.....	21	24	33	35	41	42	46	49	46	47	51	41	8.4

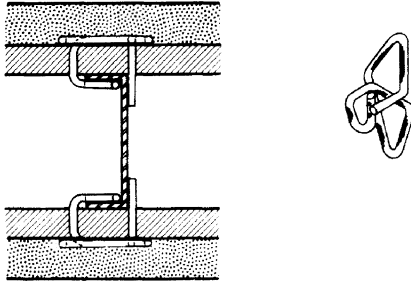

PANEL 448

PANEL 448.  $1\frac{1}{8}$ -in. steel channel studs placed 16 in. on centers in ceiling and floor tracks; studs had  $1\frac{1}{8}$ -in.-diameter holes  $\frac{1}{4}$  in. on centers. Galvanized wire loop clips, attached 16 in. on centers to both sides of the studs, held  $\frac{3}{8}$ - by 16- by 48-in. perforated gypsum lath; edges of lath joined with sheet metal clips.  $\frac{1}{16}$ -in. sanded gypsum plaster and  $\frac{1}{16}$ -in. white-coat finish applied to both sides. The airspace between lath faces measured approximately  $1\frac{1}{8}$  in., and the completed panel about  $3\frac{1}{2}$  in. thick.

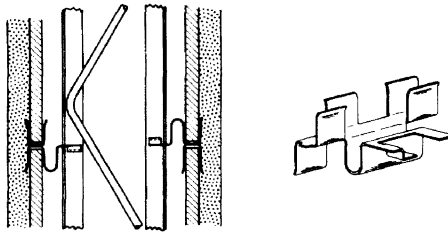

PANEL 449

PANEL 449. Similar to panel 448, except  $2\frac{1}{2}$ -in. truss type metal studs replaced channel studs; the gypsum lath was held by resilient clips. The airspace between lath faces measured approximately  $3\frac{3}{8}$  in., and the completed panel about  $5\frac{1}{4}$  in. thick.

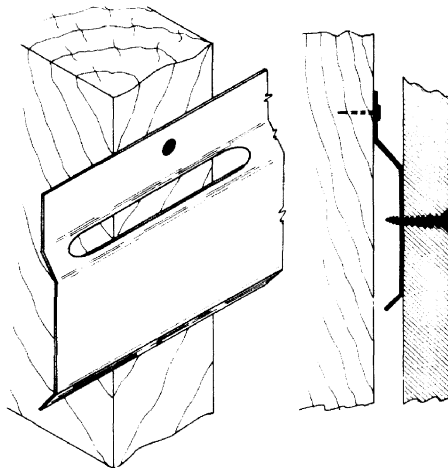

PANEL 450

PANEL 450. 2- by 4-in. wooden studs, 16 in. on centers, with resilient runners nailed horizontally to the studs 24 in. on centers.  $\frac{5}{8}$ -in. gypsum wallboard screwed, 12 in. on centers, to resilient runners; all joints taped and finished.

TABLE 2. Airborne Sound Transmission Loss—WALLS—Continued

Panel No.	Airborne sound transmission loss (in dB) at frequencies (Hz)												Weight lb/ft <sup>2</sup>
	125	175	250	350	500	700	1000	1500	2000	3000	4000	STC	
448.....	34	33	33	37	41	42	44	36	38	46	51	36	13.1
449.....	47	44	41	46	44	49	49	38	40	50	54	38	14.4
450.....	31	32	32	33	39	45	51	47	42	40	45	39	6.8

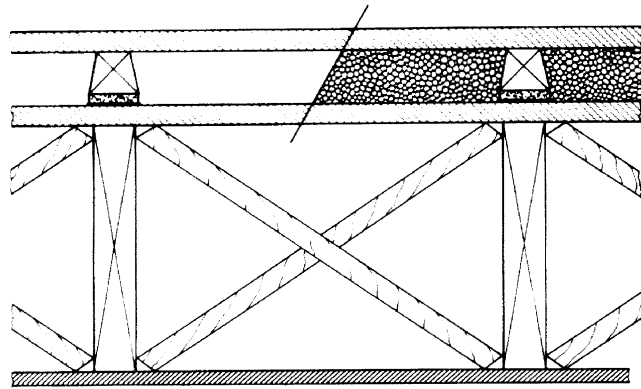

PANEL 711

PANEL 712

PANEL 711. 2- by 10-in. wooden joists 16 in. on centers, cross-braced with 1- by 3- by 18-in. wooden bridging strips bisecting length of panel between joists. On ceiling side, 1/2-in. gypsum wallboard nailed 8 in. on centers, with all joints taped and finished. On floor side, 3/4- by 3-in. subflooring, rosin paper, and floating floor consisting of 1/2- by 2-in. fiberboard strips placed 16 in. on centers in line with joists, trapezoidal (1 1/8 in. wide at top, 2 in. at bottom, 1 1/8 in. thick) sleepers nailed 16 in. on centers to fiberboard strips, and 2 1/2 in. oak flooring.

PANEL 712. Same as panel 711, except space in floating floor contained vermiculite fill. Density of fill was 7.3 lb/ft<sup>3</sup>.

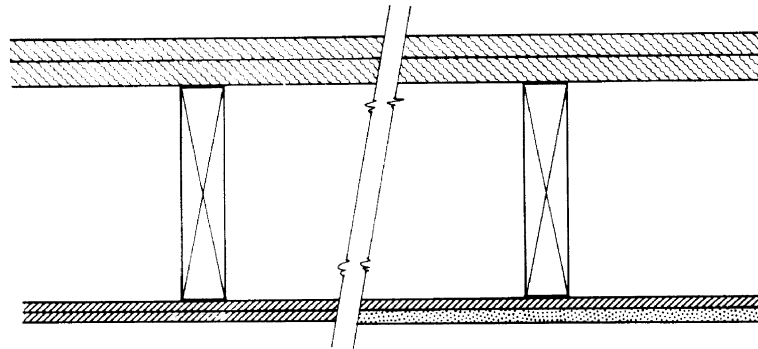

PANEL 713

PANEL 714

PANEL 713. 2- by 10-in. joists, 16 in. on centers; 1- by 6-in. tongue-and-groove subfloor; 2 1/2- by 4-in. fir finish floor; ceiling side, two layers of 3/8-in. gypsum wallboard, first layer nailed 6 in. on centers and second layer 12 in. on centers; joints taped and finished.

PANEL 714. Same as panel 713, except on ceiling side 3/8-in. perforated gypsum lath; 1/2-in. sanded gypsum plaster.

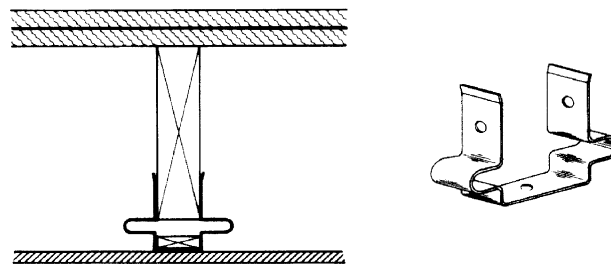

PANEL 715

PANEL 715. 2- by 8-in. wood joists, 16 in. on centers; 3/4-in. subfloor, building paper, and 3/4-in. tongue-and-groove fir finish floor; ceiling side 1/2-in. gypsum wallboard nailed to furring strips held by spring clips, the latter nailed to the floor joists; all joints taped and finished.

PANEL 716. Same as panel 715, except the 1/2-in. wallboard was nailed directly to the floor joists.

PANEL 717. 2- by 8-in. wooden joists spaced 16 in. on centers. On the floor side, 3/4-in. wood subfloor, a layer of building paper, and 3/4-in. tongue-and-groove fir finish flooring. On the ceiling side, resilient runners bridged across joists and nailed 12 in. on centers to the joists; 3/8-in. gypsum wallboard screwed to resilient runners, with all joints taped and finished. (Resilient runner similar to one illustrated with panel 450, p. 34.)

TABLE 3. Sound Transmission Loss and Impact Sound Pressure Levels (ISPL)—FLOOR-CEILING CONSTRUCTIONS

Panel No.	Airborne sound transmission loss (in dB) at frequencies (Hz)												ISPL (in dB re: 0.0002 dyne/cm <sup>2</sup> ) normalized to A <sub>0</sub> =10 m <sup>2</sup> in octave frequency bands (Hz)								Wt. lb/ft <sup>3</sup>
	125	175	250	350	500	700	1000	1500	2000	3000	4000	STC	75   150	150   300	300   600	600   1200	1200   2400	2400   4800	OA (dB)	INR	
711.....	30	20	29	30	37	40	42	---	50	---	56	*36	---	---	---	---	---	---	---	---	11.4
712.....	24	21	30	33	40	41	46	---	52	---	58	*39	---	---	---	---	---	---	---	---	12.6
713.....	28	27	28	34	32	36	44	48	52	51	55	36	---	---	---	---	---	---	---	---	12.4
714.....	33	32	26	32	33	39	41	45	48	56	62	37	---	---	---	---	---	---	---	---	15.6
715.....	47	40	40	45	52	51	54	58	58	59	63	51	---	---	---	---	---	---	---	---	9.8
716.....	34	25	24	30	36	39	42	48	51	51	56	36	---	---	---	---	---	---	---	---	9.6
717.....	43	44	41	41	41	49	52	53	50	56	60	45	70	75	72	64	62	57	78	-5	10.1

\*STC based upon nine test frequencies.

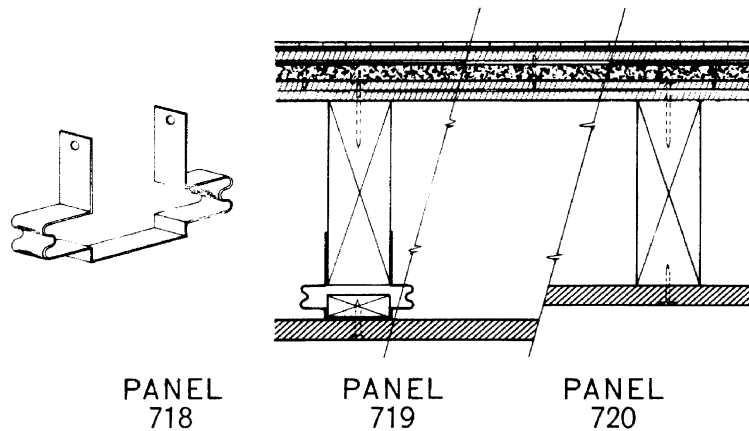

- PANEL 718. 2- by 6-in. wooden floor joists spaced 16 in. on centers. On the floor side,  $\frac{5}{8}$ -in. plyscore nailed to joists,  $\frac{1}{2}$ -in. porous wood-fiber board (approximate density 20.0 lb/ft<sup>3</sup>) stapled to subfloor,  $\frac{1}{2}$ -in. plywood underlayment glued to fiber board, and  $\frac{3}{32}$ -in. vinyl floor covering glued to underlayment board. On the ceiling side, resilient clips 24 in. on centers held 1- by 2-in. furring strips, parallel with joists, to which  $\frac{5}{8}$ -in. gypsum wallboard was screwed 12 in. on centers; all joints and screwheads taped and finished.
- PANEL 719. Similar to panel 718, except the  $\frac{1}{2}$ -in. plywood underlayment board and the  $\frac{1}{2}$ -in. wood-fiber board were nailed directly to the  $\frac{5}{8}$ -in. plyscore subfloor.
- PANEL 720. Similar to panel 718, except the resilient clips were omitted and the  $\frac{5}{8}$ -in. gypsum wallboard was nailed, 7 in. on centers, directly to the floor joists. All joints and nailheads were taped and finished.

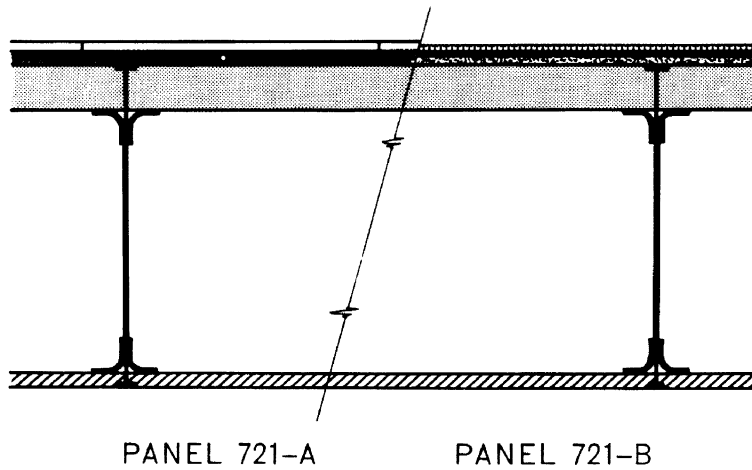

- PANEL 721-A. 8-in. steel joists spaced 16 in. on centers. (Joists had 2-in.-wide support flanges at top and bottom,  $2\frac{1}{4}$ -in. holes 30 in. on centers in  $\frac{1}{16}$ -in. thick body.) On the ceiling side,  $\frac{1}{2}$ -in. gypsum wallboard nailed 12 in. on centers, with all joints taped and finished. On the floor side,  $1\frac{1}{32}$ - by  $23\frac{1}{4}$ -in. compressed homogeneous paper pulp building board (approximate density 26.1 lb/ft<sup>3</sup>) nailed 8 in. on centers perpendicular to the joists,  $\frac{1}{8}$ -in. hardboard glued to building board, a single layer of 15 lb felt building paper glued to hardboard, and  $\frac{1}{8}$ - by 9- by 9-in. vinyl asbestos tile glued to felt paper.
- PANEL 721-B. Similar to panel 721-A, except the compressed paper pulp building board was covered with a foam rubber carpet pad and nylon carpet. The carpet pad had an uncompressed thickness of  $\frac{1}{4}$  in., backed with a woven jute fiber cloth; the rubber was perforated to approximately half its depth with holes  $\frac{1}{8}$  in. in diameter and spaced  $\frac{3}{4}$  in. on centers. The nylon carpet had  $\frac{1}{8}$ -in. woven backing and  $\frac{1}{4}$ -in. looped pile spaced seven loops per inch with a total carpet thickness of  $\frac{3}{8}$  in.
- PANEL 722-A. Similar to panel 721-A, except the steel joists were spaced 24 in. on centers and compressed paper pulp building board was  $1\frac{2}{32}$  in. thick.
- PANEL 722-B. Similar to panel 721-B, except the steel joists were spaced 24 in. on centers and the building board was  $1\frac{2}{32}$  in. thick.
- PANEL 723-A. Similar to panel 721-A, except the steel joists were replaced with 2- by 10-in. wooden joists.
- PANEL 723-B. Similar to panel 721-B, except the steel joists were replaced with 2- by 10-in. wooden joists.
- PANEL 724-A. Similar to panel 722-A, except the steel joists were replaced with 2- by 10-in. wooden joists.
- PANEL 724-B. Similar to panel 722-B, except the steel joists were replaced with 2- by 10-in. wooden joists.

TABLE 3. Sound Transmission Loss and Impact Sound Pressure Levels (ISPL)—FLOOR-CEILING CONSTRUCTIONS—Con.

Panel No.	Airborne sound transmission loss (in dB) at frequencies (Hz)												ISPL (in dB re: 0.0002 dyne/cm <sup>2</sup> ) normalized to A <sub>0</sub> =10 m <sup>2</sup> in octave frequency bands (Hz)								Wt. lb/ft <sup>2</sup>
	125	175	250	350	500	700	1000	1500	2000	3000	4000	STC	75   150	150   300	300   600	600   1200	1200   2400	2400   4800	OA (dB)	INR	
718.....	39	40	43	48	48	54	59	57	54	56	59	52	72	73	69	61	55	46	77	-2	9.6
719.....	39	34	39	47	47	52	52	51	49	53	58	50	74	75	69	60	58	49	78	-3	9.3
720.....	29	23	25	36	35	42	48	49	49	51	55	38	82	88	83	73	63	52	90	-15	9.5
721-A.....													82	82	78	66	55	51	86	-11	
721-B.....													64	54	45	30	27	24	65	+10	
722-A.....													73	75	75	68	56	51	80	-5	
722-B.....													59	47	39	26	20	12	59	+15	
723-A.....	24	17	33	29	34	41	39	44	41	41	49	*35	83	82	80	66	53	48	87	-12	8.4
723-B.....	27	20	33	33	38	44	44	50	49	54	60	38	65	56	47	32	26	14	66	+9	9.2
724-A.....													78	79	75	62	50	46	83	-8	
724-B.....													65	52	43	28	22	11	65	+9	

\*STL measured w/o hardboard, felt paper, and tile.

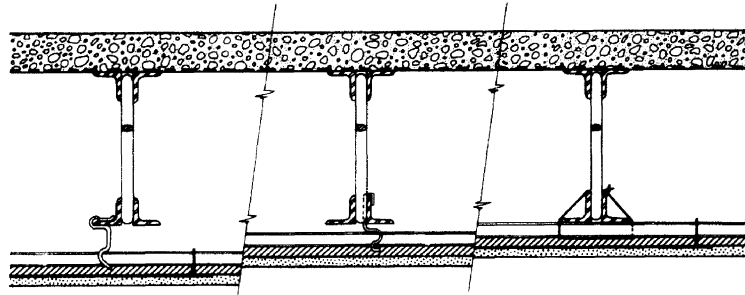

PANEL 725      PANEL 726      PANEL 727

- PANEL 725. 7-in. steel bar joists spaced 27 in. on centers. On the floor side,  $\frac{3}{8}$ -in. metal rib lath attached to top of joists, and 2-in.-thick poured concrete floor. On the ceiling side, resilient clips attached to joists held  $\frac{3}{4}$ -in. metal furring channels 16 in. on centers;  $\frac{3}{8}$ - by 16- by 48-in. plain gypsum lath held with wire clips and sheet metal end joint clips;  $\frac{1}{16}$ -in. sanded gypsum plaster and  $\frac{1}{16}$ -in. white-coat finish.
- PANEL 726. Similar to panel 725, except different resilient clips held the  $\frac{3}{4}$ -in. metal furring channels.
- PANEL 727. Similar to panel 725, except the  $\frac{3}{4}$ -in. metal furring channels were wire-tied directly to the bottom of the joists.
- PANEL 727-A. Similar to panel 727, except  $\frac{1}{8}$ -in.-thick vinyl asbestos tile was glued to concrete floor.
- PANEL 727-B. Similar to panel 727, except  $\frac{1}{4}$ -in.-thick foam rubber pad and  $\frac{3}{8}$ -in.-thick nylon loop carpet were placed on concrete floor. (Same carpet and pad as with panel 721-B.)
- PANEL 727-C. Similar to panel 727, except  $\frac{1}{2}$ -in.-thick compressed homogeneous paper pulp building board was glued to concrete floor.
- PANEL 727-D. Similar to panel 727, except  $\frac{1}{4}$ -in.-thick cork tile was glued to concrete floor.

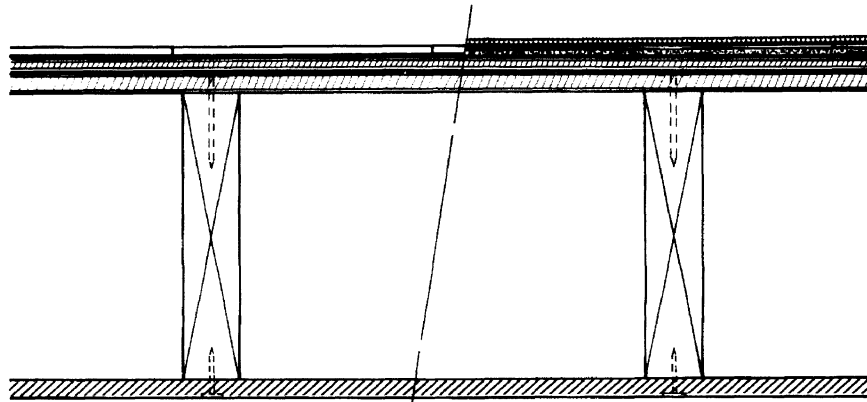

PANEL 728-A      PANEL 728-B

- PANEL 728-A. 2- by 10-in. wooden floor joists spaced 16 in. on centers.  $\frac{5}{8}$ -in. fir plywood subfloor nailed to joists 8 in. on centers;  $\frac{1}{2}$ -in. plywood underlayment nailed to subfloor with joints staggered to miss joints of the subfloor;  $\frac{1}{8}$ - by 9- by 9-in. vinyl asbestos tile glued to underlayment. On the ceiling side,  $\frac{1}{2}$ -in. gypsum wallboard nailed 12 in. on centers with all joints and nailheads taped and finished.
- PANEL 728-B. Similar to panel 728-A, except a  $\frac{1}{4}$ -in.-thick foam rubber pad and  $\frac{3}{8}$ -in.-thick nylon loop carpet replaced vinyl asbestos tile. (Same carpet and pad as used with panel 721-B.)

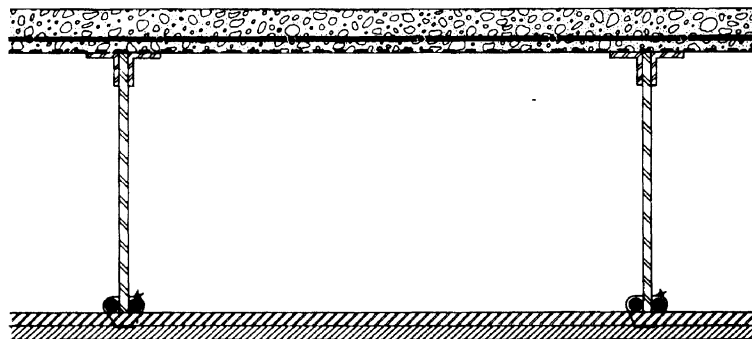

PANEL 806

- PANEL 806. 2-in. concrete slab, reinforced with 6- by 6-in. wire mesh, on  $\frac{3}{8}$ -in. metal lath; 12-in. open-web metal joists spaced 24 in. on centers; nailing channels wire-tied to joists;  $\frac{5}{8}$ -in. gypsum wallboard nailed to channels 6 in. on centers with flettering barbed nails; all joints taped and finished.
- PANEL 807. 3-in.-thick solid concrete wall poured in situ in test opening. All surface cavities were sealed with thin mortar mix. 1 to 2 in. slump concrete mixture consisted of 611 lb cement, 1480 lb sand, 1603 lb gravel, and 38 gal water per cubic yard.



TABLE 3. Sound Transmission Loss and Impact Sound Pressure Levels (ISPL)—FLOOR-CEILING CONSTRUCTIONS—Con.

Panel No.	Airborne sound transmission loss (in dB) at frequencies (Hz)												ISPL (in dB re: 0.0002 dyne/cm <sup>2</sup> ) normalized to A <sub>0</sub> =10 m <sup>2</sup> in octave frequency bands (Hz)								Wt. lb/ft <sup>2</sup>	
	125	175	250	350	500	700	1000	1500	2000	3000	4000	STC	75   150	150   300	300   600	600   1200	1200   2400	2400   4800	OA (dB)	INR		
725-----	43	41	41	44	45	49	53	48	53	58	60	48	67	68	71	74	78	69	81	-17	40.2	
726-----	43	43	48	52	49	57	56	51	52	60	60	51	65	65	65	71	74	66	77	-13	39.2	
727-----	42	41	44	43	44	47	51	51	51	58	61	48	66	67	73	76	77	68	81	-16	38.2	
727-A-----													64	65	73	74	72	58	78	-10		
727-B-----	39	41	43	40	44	48	52	53	52	61	65	46	48	39	35	27	20	9	49	+26	39.0	
727-C-----													66	64	68	59	46	32	71	+3		
727-D-----													62	67	72	70	59	42	75	-2		
728-A-----	30	19	38	32	36	38	43	47	48	46	49	37	87	85	86	82	70	64	92	-17	9.0	
728-B-----													69	57	52	40	34	19	69	+5		
806-----	40	38	40	43	46	48	51	54	53	51	54	49									34.2	
807-----	38	39	37	39	45	50	51	54	59	61	62	45									(Concrete Wall)	39.4

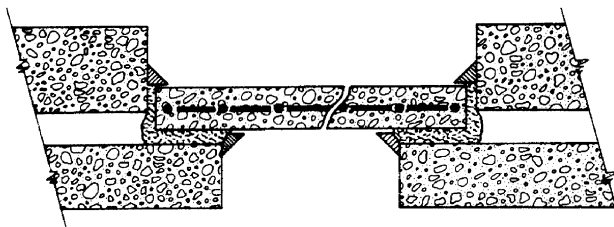

PANEL 808

- PANEL 808. 4-in.-thick reinforced concrete floor, isolated from support structure with fiberglass. Concrete mix the same as for panel 807; reinforcement consisted of 6- by 6-in. number 6 AWG reinforcing mesh placed at the centerline horizontal plane of the concrete slab. All surface cavities were sealed with a thin mortar mix.
- PANEL 808-A. Panel 808 with a floor covering of  $\frac{1}{8}$ - by 9- by 9-in. vinyl tile with an approximate density of 1.4 lb/ft<sup>2</sup>.
- PANEL 808-B. Panel 808 with a floor covering of  $\frac{1}{2}$ - by 9- by 9-in. laminated oak wood blocks with an approximate density of 1.8 lb/ft<sup>2</sup>.
- PANEL 808-C. Panel 808-B with carpeting and foam rubber pad. The carpeting was of  $\frac{1}{4}$ -in. wool loop pile with a  $\frac{1}{8}$ -in. woven jute backing and had an approximate density of 0.49 lb/ft<sup>2</sup>. The pad was  $\frac{1}{4}$ -in. thick and had an approximate density of 0.53 lb/ft<sup>2</sup>.
- PANEL 808-D. Panel 808 with same carpeting and pad as with panel 808-C.
- PANEL 809. Similar to panel 808-B, except different trowel was used which spread approximately 1.6 times more mastic per unit area.
- PANEL 809-A. Panel 809 with an underlayment of  $\frac{1}{4}$ -in.-thick polystyrene closed-cell foam, with an approximate density of 2 lb/ft<sup>3</sup>, sandwiched between two layers of kraft liner board facings, each having an approximate weight of 0.042 lb/ft<sup>2</sup>.
- PANEL 809-B. Similar to panel 809-A, except the polystyrene closed-cell foam was  $\frac{1}{8}$  in. thick with an approximate density of 4.5 lb/ft<sup>3</sup>.
- PANEL 809-C. Similar to panel 809-A, except the underlayment was  $\frac{1}{4}$ -in.-thick rigid polyurethane, approximate density 2.5 lb/ft<sup>3</sup>, between liner board facings.
- PANEL 809-D. Panel 809 with an underlayment of  $\frac{1}{2}$ -in.-thick fiber board having a density of approximately 21 lb/ft<sup>3</sup>.
- PANEL 809-E. Panel 809 with an underlayment of  $\frac{1}{4}$ -in.-thick semi-rigid polyurethane foam having an approximate density of 2.2 lb/ft<sup>3</sup>.
- PANEL 809-F. Panel 809 with an underlayment of  $\frac{1}{4}$ -in.-thick milling grade cork of mesh 8-14 to 1 in. having a density of approximately 24 lb/ft<sup>3</sup>.
- PANEL 809-G. ~~Similar to panel 809-F, except the cork was  $\frac{1}{8}$  in. thick.~~
- PANEL 809-H. Panel 809 with an underlayment of  $\frac{1}{8}$ -in.-thick molded corrugated pulp material of sulfate fibers, having approximately 33 corrugations per linear foot and an area density of approximately 0.05 lb/ft<sup>2</sup>.

C.B. 481 10/13/65

**Errata to accompany NATIONAL BUREAU OF STANDARDS MONOGRAPH 77,  
SOUND INSULATION OF WALL, FLOOR, AND DOOR CONSTRUCTIONS**

Correction on page 42:

The descriptions of Panels 809-G and 809-H should read as follows:

- Panel 809-G.** Panel 809 with an underlayment of 1/8-in.-thick molded corrugated pulp material of sulfate fibers, having approximately 33 corrugations per linear foot and an area density of approximately 0.05 lb/ft<sup>2</sup>.
- Panel 809-H.** Similar to Panel 809-F, except the cork underlayment was 1/8-in. thick.

October 13, 1965, 213.01

UNIVERSITY OF  
ARIZONA LIBRARY  
Special Collections  
NOV 5 1965

TABLE 3. Sound Transmission Loss and Impact Sound Pressure Levels (ISPL)—FLOOR-CEILING CONSTRUCTIONS—Con.

Panel No.	Airborne sound transmission loss (in dB) at frequencies (Hz)												ISPL (in dB re: 0.0002 dyne/cm <sup>2</sup> ) normalized to A <sub>0</sub> =10 m <sup>2</sup> in octave frequency bands (Hz)								Wt. lb/ft <sup>2</sup>
	125	175	250	350	500	700	1000	1500	2000	3000	4000	STC	75   150	150   300	300   600	600   1200	1200   2400	2400   4800	OA (dB)	INR	
808	48	43	42	38	45	46	56	51	57	65	66	44	63	69	79	81	82	80	87	b-26	53.2
808-A													61	67	77	80	79	76	84	b-22	
808-B													61	66	74	72	63	50	77	b-6	
808-C													44	33	34	21	12		45	b+33	
808-D													49	42	40	29	23		50	b+29	
809													65	70	77	76	68	54	80	b-9	
809-A													65	68	76	66	53	39	77	b-2	
809-B													66	70	76	74	54	48	79	b-7	
809-C													64	70	76	72	58	48	78	b-5	
809-D													65	67	75	72	54	44	78	b-5	
809-E													62	66	71	53	36	22	73	b+1	
809-F													64	67	76	75	57	45	79	b-7	
809-G													65	67	75	68	49	37	77	b-2	
809-H													65	67	76	76	58	46	80	b-8	

<sup>b</sup> INR based upon 1/3-octave frequency band data.

## Indices

As a convenience, several indices of the combined results of both publications are given here. All entries in bold-faced type refer to information contained in this monograph, and conversely,

light-faced type entries refer to information in the BMS Report 144 (1955). All STC values given for the results reported in the BMS Report 144 are based upon nine test frequencies.

### INDEX I. Numerical Index of Test Panels.

Panel No.	STC	Page	Panel No.	STC	Page	Panel No.	STC	Page	Panel No.	STC	Page
<sup>c</sup> 136-A	54	52	179-C	35	28	<sup>c</sup> 301	38	18	431	45	26
136-B	61	52	179-D	36	28	302	38	16	433	47	44
137	51	52	180-A	37	56	303	38	16	434	45	44
137-A	53	52	180-B	51	56	304	40	18	435	42	46
137-B	56	52	180-C	50	56				436	47	46
						305	42	18			
144	46	14	180-D	52	56	306	39	12	437	42	44
145	45	14	180-E	46	56	307	56	20	438	*38	28
146	33	12	180-F	49	56	308	48	14	439	44	30
147-A	41	12	181	27	10	309	37	18	440	48	30
147-B	49	12	182	27	10				441	53	30
						310	48	18			
148	40	36				311	21	14			
149	48	36	201	34	32	312	45	14	442	44	30
150	50	38	202	32	36	313	*46	28	443	46	32
151	50	38	203	31	36	314	*52	28	444	41	32
152	50	38	204	35	36				445	52	32
			205	42	30	315	*45	28	446	36	32
153	47	38				316	*47	30			
154	38	26	206	32	30	317	*53	28	447	41	32
155	44	14	207	32	30	318	*52	28	448	36	34
156	53	62	208	24	30	319	*49	30	449	38	34
157	55	62	209	40	30				450	39	34
			210	27	30						
158	55	62	211	25	28	401	42	38			
159	34	50	212	43	28	402	43	38	501	29	26
160-A	56	50	213	53	30	403	41	38	502	35	26
160-B	55	50	214	28	28	404	41	38	503	34	20
160-C	55	50	215	50	28	405	43	38	504	34	22
									505	35	24
160-D	52	50	216	36	28	406	41	38			
160-E	51	50	217	40	28	407	41	38	506	37	22
160-F	50	50	218	38	28	408	44	38	507	41	24
160-G	50	50	219	41	30	409	41	38	508	41	24
160-H	47	50	220	53	30	410	46	38	509	49	24
									510	34	22
160-I	47	50	221	49	50	411	42	38			
161	39	18	222	57	48	412	47	38			
162	43	32	223	56	48	413	46	40	511	38	22
163	31	32	224	38	34	414	47	40	512	39	22
164	45	32	225	40	34	415	42	40	513	38	24
									514	42	24
165	37	32	226	40	36				515	38	24
166-A	39	48	227	40	36	416	45	42			
166-B	39	48	228	41	32	417	44	42			
167	51	38	229	41	48	418	49	42	516	36	22
168	57	38	232	34	12	419	48	42	517	30	22
						420	52	42	518	36	26
			233	43	12				519	31	26
170	35	26	234	37	34				520	42	22
171-A	37	26	235	42	34	421	51	42			
171-B	34	26	236	46	36	422	50	42			
171-C	33	26	237	*43	24	423	53	42	521	32	22
172	39	26	238	*48	24	424	51	44	522	38	22
			239	44	24	425	53	34	523	37	26
173-A	38	14	240	36	24				524	38	26
173-B	35	14	241	41	24	426	43	46	525	31	26
173-C	12	14	242	44	26	427	46	46			
174	36	32	243	44	26	428	43	22	526	31	20
175	51	34	244	44	26	429	54	50	527	38	20
			245	43	26	430	45	26	528	32	22
176	49	40	246	43	26						
177	38	40	247	48	26						
178	47	40	250	25	24						
179-A	33	28	251	39	26						
179-B	36	28									

\*STC based upon nine test frequencies.

<sup>c</sup> All entries in light-faced type refer to BMS Report 144 (1955) with STC values based upon nine test frequencies.

INDEX I. Numerical Index of Test Panels—Continued

Panel No.	STC	Page	Panel No.	STC	Page	Panel No.	STC	INR	Page	Panel No.	STC	INR	Page
* 601	27	10	631	30	8	* 701	43		54				
602	31	12	632	30	8	702	47		54	727	48	-16	40
603	37	12	633	18	8	703	43		54	727-A		-10	40
604	37	12	634	20	8	704	46		54	727-B	46	+26	40
605	30	10	635	24	10	705	57		58	727-C		+3	40
										727-D		-2	40
606	19	10	636	26	10	706	54		58				
607	38	10	637	32	10	707	42		52	728-A	37	-17	40
608	*43	16	638	30	10	708	40		52	728-B		+5	40
609	*47	16	639	35	10	709	52		58				
610	*48	18	640	34	10	710	52		58				
										* 801	42		60
611	*62	18	641	42	10	711	*36		36	802	48		60
612	35	10	642	46	10	712	*39		36	803	47		60
613	41	10	643	49	12	713	36		36	804	48		60
614	*59	18	644	50	12	714	37		36	805	49		60
615	*45	18	645	34	12	715	51		36				
										806	49		40
616	*30	6				716	36		36	807	45		40
617	*28	6	646	25	14	717	45	-5	36	808	44	-26	42
618	*33	6	646-A	21	14	718	52	-2	38				
619	*33	6	647	32	20	719	50	-3	38	808-A		-22	42
620	*30	6	648	24	20	720	38	-15	38	808-B		-6	42
			649	33	20					808-C		+33	42
621	*35	6				721-A		-11	38	808-D		+29	42
622	*44	6	650	41	22	721-B		+10	38	809		-9	42
623	*38	6	651	37	14	722-A		-5	38	809-A		-2	42
624	*38	8	652	29	14	722-B		+15	38				
625	*41	8	653	36	16	723-A	35	-12	38	809-B		-7	42
			654	47	16					809-C		-5	42
626	*32	8				723-B	38	+9	38	809-D		-5	42
627	*23	18	655	36	22	724-A		-8	38	809-E		+1	42
628	*21	20	656	34	22	724-B		+9	38	809-F		-7	42
629	*25	20	657	26	22	725	48	-17	40	809-G		-2	42
630	35	8	658	32	22	726	51	-13	40	809-H		-8	42

\*STC based upon nine test frequencies.

\* All entries in light-faced type refer to BMS Report 144 (1955) with STC values based upon nine test frequencies.

INDEX IIA. Sound Transmission Class Index of Test Panels

A. DOORS—Type code:

- a. solid core
- b. hollow core
- c. special construction
- d. metal
- e. folding
- f. w/drop closure

STC	Panel No.	Type	Page
50	644	d, c, f	12
49	643	d, c	12
47	654	d, c	16
46	642	c, f	10
*44	622	c, f	6
42	641	c, f	10
* 41	613	c, f	10
*41	625	c, f	8
*38	623	c, f	6
*38	624	c, f	8
37	651	c, f	14
36	653	d, c, f	16
35	612	c, f	10
*35	621	c, f	6
35	630	c, f	8
35	639	c	10
34	640	c, f	10
34	645	d, c	12
*33	618	c, f	6
*33	619	c, f	6

STC	Panel No.	Type	Page
*32	626	c, f	8
32	637	c, f	10
*30	616	a, f	6
*30	620	c, f	6
30	631	c, f	8
30	632	a, f	8
30	638	c, f	10
29	652	c, f	14
*28	617	a, f	6
27	181	a, f	10
27	182	a, f	10
26	636	c	10
25	646	e	14
24	635	c	10
21	646-A	e	14
20	634	b	8
18	633	b	8

\*STC based upon nine test frequencies.  
 \* All entries in light-faced type refer to BMS Report 144 (1955) with STC values based upon nine test frequencies.

INDEX IIB. Sound Transmission Class Index of Test Panels

INDEX IIB. Sound Transmission Class Index of Test Panels—Continued

B. WALLS—Type code:

- a. wood stud
- b. metal stud
- c. masonry
- d. concrete
- e. staggered stud

- f. lath & plaster
- g. gypsum wallboard
- h. w/resilient element
- i. movable partition
- j. wooden panel

STC	Panel No.	Type	Page
c 57	168	a, f, h	38
57	222	b, f	48
56	160-A	b, f	50
56	223	b, f	48
56	307	c	20
55	160-B	b, f	50
55	160-C	b, f	50
54	429	b, f, h	50
53	213	a, f	30
53	220	a, f	30
*53	317	c, f, h	28
53	423	a, f, h	42
53	425	a, f, h	34
53	441	b, f, h	30
52	160-D	b, f	50
*52	314	c, f, h	28
*52	318	c, f, h	28
52	420	a, f, h	42
52	445	a, g, h	32
51	160-E	b, f	50
51	167	a, f, h	38
51	175	a, e, f	34
51	421	a, f, h	42
51	424	b, f	44
50	150	a, f, h	38
50	151	a, f, h	38
50	152	a, f, h	38
50	160-F	b, f	50
50	160-G	b, f	50
50	215	a, e, g, j	28
50	422	a, f, h	42
49	176	a, f, h	40
49	221	b, f	50
*49	319	c, f, h	30
49	418	a, f, h	42
49	509	f	24
48	149	a, f	36
*48	238	a, e, f	24
48	247	b, g	26
48	308	c	14
48	310	c, f, h	18
48	419	a, f, h	42
48	440	b, f	30
47	153	a, f	38
47	160-H	b, f	50
47	160-I	b, f	50
47	178	a, f	40
*47	316	c, f, h	30
47	412	a, f, h	38
47	414	a, f, h	40
47	433	b, f	44
47	436	b, f, h	46

B. WALLS—Type code:

- a. wood stud
- b. metal stud
- c. masonry
- d. concrete
- e. staggered stud

- f. lath & plaster
- g. gypsum wallboard
- h. w/resilient element
- i. movable partition
- j. wooden panel

STC	Panel No.	Type	Page
c 46	144	c	14
46	236	a, e, g, h	36
*46	313	c, f, h	28
46	410	a, f, h	38
46	413	a, f, h	40
46	427	b, f	46
46	443	a, f, h	32
45	145	c	14
45	164	a, f	32
45	312	c	14
*45	315	c, f, h	28
45	416	a, f	42
45	430	f	26
45	431	f	26
45	434	b, f	44
45	807	d	40
44	155	c	14
44	239	a, f	24
44	242	a, e, g	26
44	243	a, e, g	26
44	244	a, e, g	26
44	408	a, f, h	38
44	417	a, f	42
44	439	a, f, h	30
44	442	a, f, h	30
43	162	a, f	32
43	212	a, g, j	28
*43	237	a, e, f	24
43	245	a, e, f	26
43	402	a, f, h	38
43	405	a, f, h	38
43	426	b, f	46
43	428	g, h	22
42	205	a, f	30
42	235	a, e, g	34
42	305	c	18
42	401	a, f, h	38
42	411	a, f, h	38
42	415	a, f, h	40
42	435	b, e, f	46
42	437	b, f	44
42	514	f	24
42	520	f	22
41	219	a, j	30
41	228	a, f	32
41	229	b, f	48
41	241	a, g	24
41	403	a, f, h	38
41	404	a, f, h	38
41	406	a, f, h	38
41	407	a, f, h	38
41	409	a, f, h	38
41	444	b, f, h	32
41	447	b, g	32
41	507	f	24
41	508	f	24
41	650	i, b	22

\*STC based upon nine test frequencies.  
 c All entries in light-faced type refer to BMS Report 144 (1955) with STC values based upon nine test frequencies.

INDEX IIB. Sound Transmission Class Index of Test Panels—Continued

B. WALLS—Type code:

- a. wood stud
- b. metal stud
- c. masonry
- d. concrete
- e. staggered stud
- f. lath & plaster
- g. gypsum wallboard
- h. w/resilient element
- i. movable partition
- j. wooden panel

STC	Panel No.	Type	Page
<sup>c</sup> 40	148	a, f	36
40	209	a, g	30
40	217	a, j	28
40	225	a, g	34
40	226	a, f	36
40	227	a, f	36
40	304	c	18
39	161	c	18
39	166-A	b, f	48
39	166-B	b, f	48
39	172	b, f	26
<sup>39</sup>	<sup>251</sup>	<sup>a, f</sup>	<sup>26</sup>
39	306	c	12
<sup>39</sup>	<sup>450</sup>	<sup>a, g, h</sup>	<sup>34</sup>
39	512	f	22
38	154	b, f	26
38	173-A	c	14
38	177	a, f	40
38	218	a, g, j	28
38	224	a, g	34
38	301	c	18
38	302	c	16
38	303	c	16
<sup>*38</sup>	<sup>438</sup>	<sup>b, f</sup>	<sup>28</sup>
<sup>38</sup>	<sup>449</sup>	<sup>b, f, h</sup>	<sup>34</sup>
38	511	f	22
38	513	f	24
38	515	f	24
38	522	g	22
38	524	b, f	26
38	527	f	20
37	165	a, f	32
37	171-A	b, f	26
37	234	a, g	34
37	309	c	18
37	506	f	22
37	523	b, f	26
36	174	a, f	32
36	179-B	a, j	28
36	179-D	a, j	28
36	216	a, g, j	28
36	240	a, g	24
36	446	b, f, h	32
36	448	b, f	34
36	516	f	22
36	518	b, f	26
36	655	i, b, g	22

INDEX IIB. Sound Transmission Class Index of Test Panels—Continued

B. WALLS—Type code:

- a. wood stud
- b. metal stud
- c. masonry
- d. concrete
- e. staggered stud
- f. lath & plaster
- g. gypsum wallboard
- h. w/resilient element
- i. movable partition
- j. wooden panel

STC	Panel No.	Type	Page
<sup>c</sup> 35	170	b, f	26
35	173-B	c	14
35	179-C	a, j	28
35	204	a, f	36
35	502	b, f	26
35	505	f	24
34	159	b, f	50
34	171-B	b, f	26
34	201	a, f	32
34	503	f	20
34	504	f	22
34	510	f	22
34	656	i, b, g	22
33	171-C	b, f	26
33	179-A	a, j	28
33	649	i	20
32	202	a, f	36
32	206	a, j	30
32	207	a, j	30
32	521	f	22
32	528	g	22
32	647	i	20
31	163	a, f	32
31	203	a, f	36
31	519	b, f	26
31	525	b, f	26
31	526	f	20
30	517	f	22
29	501	b, f	26
28	214	a, e, j	28
27	210	a, j	30
26	657	i, b	22
25	211	a, j	28
24	208	a, g	30
24	648	i	20
21	311	c	14
12	173-C	c	14

\*STC based upon nine test frequencies.  
<sup>c</sup> All entries in light-faced type refer to BMS Report 144 (1955) with STC values based upon nine test frequencies.

INDEX IIC. Sound Transmission Class Index of Test Panels

C. FLOOR-CEILING CONSTRUCTIONS—Type code:

- a. wood joist
- b. metal joist
- c. concrete
- d. lath & plaster
- e. gypsum board
- f. w/resilient elements

STC	Panel No.	Type	INR	Page
c 61	136-B	b, c, d		52
57	705	a, d, f		58
56	137-B	b, c, d		52
55	157	c, d, f		62
55	158	c, d, f		62
54	136-A	b, c, d		52
54	706	a, d		58
53	137-A	b, c, d		52
53	156	c, d, f		62
52	180-D	a, d, f		56
52	709	a, d, f		58
52	710	a, d, f		58
52	718	a, e, f	-2	38
51	137	b, c, d		52
51	180-B	a, d, f		56
51	715	a, e, f		36
51	726	b, c, d, f	-13	40
50	180-C	a, d, f		56
50	719	a, e, f	-3	38
49	180-F	a, d, f		56
49	805	c		60
49	806	b, c, e		40
48	725	b, c, d, f	-17	40
48	727	b, c, d	-16	40
48	802	c, d		60
48	804	c		60
47	702	a, d		54
47	803	c, d		60
46	180-E	a, d, f		56
46	704	a, d		54
46	727-B	b, c, d	+26	40
45	717	a, e, f	-5	36
44	808	c	-26	42
43	701	a, d		54
43	703	a, d		54
42	707	a		52
42	801	c, d		60
40	708	a, d		52
*39	712	a, e, f		36
38	720	a, e	-15	38
38	723-B	a, e	+9	38
37	180-A	a, d		56
37	714	a, d		36
37	728-A	a, e	-17	40
*36	711	a, e, f		36
36	713	a, e		36
36	716	a, e		36
35	723-A	a, e	-12	38

\*STC based upon nine test frequencies.  
 ° All entries in light-faced type refer to BMS Report 144 (1955) with STC values based upon nine test frequencies.

INDEX IID. Sound Transmission Class Index of Test Panels

D. MISCELLANEOUS—Type code:

- a. plastic panels
- b. aircraft fuselage
- c. ship structures
- d. single layer of material

STC	Panel No.	Type	Page
*62	611	c	18
*59	614	c	18
c 49	147-B		12
*48	610	c	18
*47	609	c	16
*45	615	c	18
43	233		12
*43	608	c	16
41	147-A		12
38	607		10
37	603		12
37	604		12
34	232	d	12
33	146		12
32	658	a	22
31	602		12
30	605	d	10
27	601		10
25	250	a	24
*25	629	b	20
*23	627	b	18
*21	628	b	20
19	606	d	10

\*STC based upon nine test frequencies.  
 ° All entries in light-faced type refer to BMS Report 144 (1955) with STC values based upon nine test frequencies.

### Appendix: Conversion of Units to International System Units

The following table gives the conversion factors necessary to convert the units of the various quantities given in this publication in units other than the International System to the units of that system which were adopted by the Eleventh General Conference on Weights and Measures, Paris, October 11-20, 1960.

- Area: 1 sq foot (ft<sup>2</sup>)=0.092903 sq meter (m<sup>2</sup>)
- Area density: 1 pound per sq foot (lb/ft<sup>2</sup>)=4.88243 kilogram per sq meter (kg/m<sup>2</sup>)
- Frequency: 1 cycle per second (c/s)=1 hertz (Hz)
- Length: 1 inch (in.)=0.0254 meter (m)
- 1 foot (ft)=0.3048 meter (m)
- Pressure: 1 dyne per sq centimeter (dyne/cm<sup>2</sup>)=0.1 newton per sq meter (N/m<sup>2</sup>)

Volume: 1 cubic foot (ft<sup>3</sup>)=0.0283168 cubic meter (m<sup>3</sup>)



**INDEX III. Impact Noise Rating Index of Floor-Ceiling  
Constructions**

Type code:

- |                           |                                |
|---------------------------|--------------------------------|
| a. wood joist             | e. gypsum board ceiling        |
| b. metal joist            | f. w/resilient ceiling element |
| c. concrete               | g. w/resilient floor element   |
| d. lath & plaster ceiling | h. w/carpeting                 |

INR	Panel No.	Type	STC	Page
+ 33	808-C	c, h		42
+ 29	808-D	c, h		42
+ 26	727-B	b, c, d, h	46	40
+ 15	722-B	b, e, h		38
+ 10	721-B	b, e, h		38
+ 9	723-B	a, e, h	38	38
+ 9	724-B	a, e, h		38
+ 5	728-B	a, e, h		40
+ 3	727-C	b, c, d		40
+ 1	809-E	c, g		42
- 2	718	a, e, f, g	52	38
- 2	727-D	b, c, d		40
- 2	809-A	c, g		42
- 2	809-G	c, g		42
- 3	719	a, e, f, g	50	38
- 5	717	a, e, f	45	36
- 5	722-A	b, e		38
- 5	809-C	c, g		42
- 5	809-D	c, g		42
- 6	808-B	c		42
- 7	809-B	c, g		42
- 7	809-F	c, g		42
- 8	724-A	a, e		38
- 8	809-H	c, g		42
- 9	809	c		42
- 10	727-A	b, c, d		40
- 11	721-A	b, e		38
- 12	723-A	a, e	35	38
- 13	726	b, c, d, f	51	40
- 15	720	a, e, g	38	38
- 16	727	b, c, d	48	40
- 17	725	b, c, d, f	48	40
- 17	728-A	a, e	37	40
- 22	808-A	c		42
- 26	808	c	44	42





