

Spectrophotometric sensor system based on a liquid waveguide capillary cell for the determination of titanium: Application to natural waters, sunscreens and a lake sediment

Ricardo N.M.J. Páscoa^a, Ildikó V. Tóth^b, Agostinho A. Almeida^b, António O.S.S. Rangel^{a,*}

^a CBQF/Escola Superior de Biotecnologia, Universidade Católica Portuguesa, Rua Dr. António Bernardino de Almeida, 4200-072 Porto, Portugal

^b REQUIMTE, Departamento de Química, Faculdade de Farmácia, Universidade do Porto, Rua Aníbal Cunha, 164, 4050-047 Porto, Portugal

A B S T R A C T

An analytical procedure for the spectrophotometric determination of titanium at trace levels was developed. The procedure involves the use of a multi-pumping flow system (MPFS) coupled with a liquid waveguide capillary cell (LWCC) with 1.0 m path length, 550 μm i.d. and 250 μL internal volume, which enabled to enhance the sensitivity of the determination and thus avoid complex and time-consuming pre-concentration steps. The determination is based on the colorimetric reaction of titanium with chromotropic acid. The limit of detection (3σ) was 0.4 $\mu\text{g/L}$ and a linear response up to 100 $\mu\text{g/L}$ with a sample throughput of 46 h^{-1} , and a low reagent consumption/effluent production was achieved. The developed procedure was applied to natural waters, sunscreen formulations and one certified lake sediment sample.

Keywords:

Titanium

Multi-pumping flow system

Liquid waveguide capillary cell

Spectrophotometry

Trace analysis

1. Introduction

Titanium is the ninth most abundant element in earth's crust, a natural constituent of rocks, soils and sediments [1]. The levels of Ti in rocks are lower than 2% (w/w) [2]. The Ti concentrations found in riverine, estuarine and coastal waters range from 0.005 to more than 4.8 $\mu\text{g/L}$ [3] and from 0.2 to 17 ng/L in ocean waters [1]. The Ti minerals are very resistant to chemical weathering in soil and sedimentary environments, allowing the common use of Ti as a guide element to compare the mobility of the different elements [1].

In recent years, Ti has acquired growing importance in several industrial fields because of its particular physical and chemical characteristics. The main commercially available compound, titanium dioxide, is used in solar energy cells [4], as a photocatalyst in sterilization, air cleaning and water purification processes [5,6], as an ingredient of sunscreens, cosmetics, toothpastes, paints and plastics, and in the manufacture of building materials, aircrafts and missiles [7,8]. It also shows great promise in the development of antitumor agents [9], and for drug delivery, environmental cleanup and computer manufacture [10]. Titanium dioxide nanoparticles also shows durable photocatalytic activity, induced by UV-light, causing photochemical degradation of organic

compounds [6,11], suggesting a potential use in wastewater treatment plants [8].

TiO₂ in the form of nanoparticles is not considered as new materials, as bulk TiO₂ has been incorporated into various products as a white pigment for decades; it is therefore categorized as a new form of an existing substance. Nanoparticles are ultrafine particles with length in two or three dimensions greater than 1 nm and smaller than 100 nm [10,12]. Despite the large scale and increasing production of these materials, few studies have addressed the possible environmental threat posed by nanoparticles.

The nanoparticles toxicity differs with particle type, size, surface area and functional groups attached [6,12]. Oberdörster et al. revealed that the smaller the size of the nanoparticles, stronger the exerted toxicity is [13], although the relation between the physicochemical properties of nanoparticles and their toxicity appears to be more complex [14].

In a recent study [15], based on the already existing quantitative toxicity data (ex. LC₅₀ or EC₅₀) for the evaluation of the potential hazardous effects of nanoparticles [16], TiO₂ was classified as "harmful". This classification is based on studies that involved different groups of organisms (crustaceans, bacteria, algae, fish, nematodes and yeasts) and concluded that algae are the most sensitive ones. In the case of bulk TiO₂ the toxicity falls into the same classification, showing a lowest LC₅₀ value for algae, similar to the value found for the nanoparticles formulation.

The aquifers may be the principal receiver of nanotechnology industry discharges. Therefore, ecotoxicology studies on water col-

* Corresponding author. Tel.: +351 225580064; fax: +351 225090351.

E-mail address: aorangel@esb.ucp.pt (A.O.S.S. Rangel).

umn organisms and across several taxonomic groups are of great interest for the comprehensive effect assessment of the nanoparticles in the aquatic environment [5,7,14,17,18].

The development of analytical methods focused on understanding the fate of nanoparticles in the aquatic environment is important, as the lack of detection/quantification tools hampers the advancements on other areas related to its toxicity.

In general, flow systems are very suitable for water analysis because of increased accuracy, good repeatability, low equipment cost, high sample throughput, simplified sample handling, reduced contamination risks, high degree of automation and reduction in sample/reagents consumption and effluent production [19,20].

Regarding flow methodologies for the determination of Ti, the majority are based on molecular absorption spectrophotometry [2,8,21,22], although there are some works exploiting other detection techniques such as chemiluminescence [23], ICP-AES [24] and ICP-MS [25].

The spectrophotometric procedures are simple, fast and robust and there are some colorimetric reagents used for titanium determination as chromotropic acid, tiron, sulfosalicylic acid [2] and 4,4'-diantipyrilmethane [21]. However, to reach the determination of titanium at trace levels with spectrophotometric procedures, a preconcentration step is necessary [26], significantly increasing the complexity of the flow systems manifold and decreasing the determination rate.

To overcome these difficulties, in this work we propose the use of a liquid waveguide capillary cell (LWCC), a sample cell where the optical path length is increased without light attenuation [27], which enables to significantly increase sensitivity, in order to attain the direct determination (i.e., without a pre-concentration step) of trace levels of titanium in samples of different types (as natural waters, sunscreens and lake sediments). This approach was already successfully used in the determination of iron at low concentration levels [28]. The characteristics of this device permit total internal reflection of the light on the walls as the light conducting path is transparent to the wavelength of interest and has a refractive index higher than the walls material. Thus, light is kept in the optically denser core.

To carry out the in-line sample reaction needed for the spectrophotometric determination of Ti, an option was made for the utilization of a manifold based on the recently proposed multi-pumping flow technique. This is characterized by a pulsed flow capable of producing an improved sample/reagent mixing and reaction zone homogenization [29]. Multi-pumping flow systems (MPFS) use multiple low-cost solenoid micro-pumps strategically positioned in the manifold, which, when controlled by computer software, provide easy and versatile automated fluid handling operations. The solenoid micro-pumps require low-power supply voltage to work and have a small size when compared to peristaltic pumps, making it an advantageous alternative for portable equipment/in situ analysis.

2. Experimental

2.1. Reagents and solutions

All solutions were prepared with analytical reagent-grade chemicals and deionized water. Titanium (IV) stock standard solution (100 mg/L) was prepared by diluting the respective 1000 mg/L atomic absorption standard (Fluka, 04689) with 0.01 mol/L HCl solution. Calibrating solutions in the range of 10–100 µg/L were daily prepared by rigorous dilution of the Ti stock solution with 0.01 mol/L HCl.

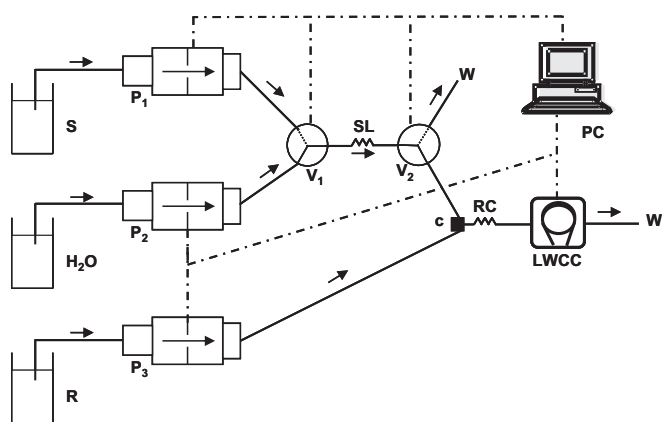

Fig. 1. Multi-pumping flow system for the determination of titanium. Pi, pumps; Vi, solenoid valves; SL, sample loop (200 µL); RC, reaction coil (50 cm); c, confluence; LWCC, detector (100 cm optical path, 425 nm); PC, computer; W, waste; S, sample or standard; and R, colour reagent (chromotropic acid) and buffer solution (acetate buffer with ascorbic acid).

A certified reference material (CRM), a lake sediment sample ref.^a IAEA-SL-1, was analysed in order to evaluate the accuracy of the developed analytical procedure.

Five sunscreen samples were also analysed by the developed method and the results obtained were compared with the alternative ICP MS procedure.

The TiO₂ nanoparticles (<100 nm) used in the recovery tests performed with the CRM sample were from Sigma–Aldrich (Ref. 634662).

The solutions used in interference studies were prepared by diluting commercial atomic absorption standard solutions (Spectrosol, BDH) of Fe, Al, Cu or Pb by dissolving the respective salts NH₄VO₃, K₂Cr₂O₇ and NaF (Merck), in the case of V, Cr and F.

Chromotropic acid colour reagent was daily prepared by dissolving 0.025 g of C₁₀H₆Na₂O₈S₂·2H₂O (Sigma–Aldrich) and 1.0 g of ascorbic acid (VWR International) in 100 mL of a 0.2 mol/L acetic acid–sodium acetate solution, resulting in a solution with 1.25 mmol/L and 0.113 mol/L of chromotropic acid and ascorbic acid, respectively.

2.2. Apparatus

The manifold used for the determination of Ti is shown in Fig. 1 and comprised three micro-pumps (Bio-Chem Valve Inc., Boonton, NJ, USA, Ref. 120SP1220 and 120SP1230), with nominal dispensing volumes of 20 and 30 µL per stroke, and two commutation valves (NResearch, Caldwell, NJ, USA, Ref 161T031) with an internal volume of 27 µL. To control both micro-pumps and commutation valves, an I/O digital card with eight optocoupled digital input channels and eight digital relay output channels was used. This card was connected to a personal computer through an RS485/RS232 interface and can independently control the operation of up to eight micro-pumps and/or commutation valves. These devices are set on a motherboard connected to a protection interface, which is connected to the relay outputs and an additional power source of 12 V is required to activate the solenoid devices. In order to minimize the heat generation and extend the lifetime of the valves, a solenoid protection system (Sciware, Mallorca, Spain) was used. The power source, the RS serial interface and the I/O cards were integrated into a unique module (Ref. Module1 Sciware). The volumes dispensed by the micro-pumps in each stroke were verified and are shown in Table 1.

For the solenoid valves, the exchange options were classified in on/off lines. The “on” line was assigned to the flow manifold and

Table 1

Volumes actually propelled by the MPFS micro-pumps.

Micro-pump	Nominal volume per stroke (μL)	Actual volume per stroke (μL) ^a
P ₁	20	14.0 \pm 0.1
P ₂	20	17.2 \pm 0.1
P ₃	30	20.4 \pm 0.4

^a Mean and standard deviation of 20 replicates.

the “off” line to the solutions flasks (represented with a solid line and dotted line, respectively, on Fig. 1).

The connection of the different components of the flow system was made with PTFE tubes with 0.8 mm id (Omnifit, Cambridge, UK). End-fitting and connectors (Gilson, Villiers-le-Bel, France) were also used. The sample loop (SL) and the reaction coil (RC) were 40 and 50 cm long, respectively.

A personal computer Pentium II, running AutoAnalysis version 5.0.3.5 software (Sciware), controlled the micro-pumps and the commutation valves.

The spectrophotometric measurements were carried out at 425 nm. Reference wavelength for minimizing the schlieren effect was set at 800 nm [30]. The principle of the signal compensation is to measure simultaneously the signal at two different wavelengths: one at which the reaction product absorbs predominantly the light and a reference wavelength at which no absorbance change due to the chemical reaction is observed.

As detection system, an Ocean Optics PC2000-ISA spectrophotometer (Dunedin, FL, USA), two 200 μm fibre optic cables, a DH-2000 deuterium halogen light source (Top Sensor Systems, Eerbeek, The Netherlands) and a liquid waveguide capillary cell (LWCC 2100; World Precision Instruments, Sarasota, FL, USA) with 1.0 m path length, 250 μL inner volume and 550 μm inner diameter was used. Data acquisition was also performed by the Sciware AutoAnalysis software.

An Anton Paar (Graz, Austria) Multiwave 3000 microwave oven, with a rotating turntable (a 16MF100/HF100 rotor with sixteen PTFE vessels of 50 mL maximum capacity), a 2455 MHz magnetron and a nominal exit power of 1400 W was employed for acid digestion of the samples.

A VG Elemental (Winsford, UK), PlasmaQuad 3 ICP-MS instrument, equipped with a Meinhard type A pneumatic concentric nebulizer, a quartz water cooled impact-bead spray chamber, a standard quartz tube torch and nickel sample and skimmer cones, was used in the comparison method. Both the spray chamber and sampling interface were cooled to 10 °C by circulating water. Argon of 99.9999% purity (Alphagaz 2, supplied by Air Liquide, Maia, Portugal) was used as plasmogenic gas. For ICP-MS sample introduction and waste draining, a Gilson Minipuls 3 peristaltic pump was used. The main operating conditions for the ICP-MS determination of Ti are indicated in electronic Supplementary data in Table S1. The isotopes (m/z ratios) ⁴⁷Ti (as analyte) and ⁴⁵Sc (as internal standard) were monitored. Both the ICP-MS instrument control and data acquisition were accomplished by using the VG Elemental PlasmaLab software.

Table 2

MPFS sequence of operations for the determination of titanium.

Step	Pump	Volume (mL)	Flow rate (mL/min)	Valve position		Action
				V1	V2	
1	P ₂	0.5	5	1	1	Sampling
2	P ₁	0.1	1	0	0	Propelling sample with carrier to the confluence
3	P ₁ and P ₃	0.1 C 0.1 R	1	0	0	Propelling sample with carrier and colour reagent to the detector
4	P ₁	5	5	0	0	Propelling the mixture to the detector and signal registration

C, carrier; R, colour reagent; 0, off; 1, on.

2.3. MPFS configuration and procedure

The MPFS (Fig. 1) was designed to allow the determination of titanium in waters, cosmetic and other environmental samples digests at very low levels. The set-up included three solenoid pumps and two commutation valves. The volume of the sample introduced into the MPFS can be set by controlling the volume dispensed in each stroke and/or the frequency of the strokes, however, the analytical repeatability is affected by the variation of the dispensed volume. Therefore, an option for a volume-based sample injection was taken, instead of a time-based injection approach. To implement this strategy, two commutation valves were used and the sample volume was controlled by the length of the sample loop placed between them. A confluence point was added downstream to promote mixing between sample/standard and colour reagent.

The operation sequence of the MPFS is listed in Table 2. The first step consisted of the introduction of 500 μL of sample/standard in the SL by pump 2. Subsequently, the sample/standard and colour reagent (100 μL) were propelled to the confluence by pump 2 and 3, respectively. In the final step, the resulting mixture was propelled to the detector and the analytical signal was registered.

At the end of a working day, the LWCC was sequentially washed in counter current with HCl (0.05 mol/L) and NaOH (0.05 mol/L) solutions, and finally with water.

2.4. Microwave digestion procedure

The microwave digestion procedures used for each type of samples are summarized in electronic complementary data in Table S2. Samples were directly weighed into the PTFE reactors of the microwave digestion unit and, after addition of the digestion reagents, the mixture was subjected to the following program: a pre-set time period to attain the maximum power of 800 W, followed by a holding period at this power and a 15 min cooling period at 0 W. After that, and to complex free fluoride, saturated boric acid solution was added at a ratio of 6 ml per each mL of HF used in the digestion. The resulting clear solutions were quantitatively transferred to volumetric flasks and, after appropriate dilution with deionized water, they were analysed both by the developed and the reference procedure.

3. Results and discussion

3.1. Study of physical and chemical parameters of the MPFS

The optimization studies included both physical parameters (flow rate, plug size, reaction coil length, sample and reagent volumes) and chemical parameters (reagents concentration and pH) of the whole analytical procedure. The univariate method was used, where only one parameter was changed while the others were kept constant. The results are summarized in Fig. 1 and in Table 2.

Initially, the volumes actually dispensed by the micro-pumps were evaluated. Two different flow rates (1 and 5 mL/min) and two different volumes (1 and 5 mL) were selected to perform this evaluation in each micro-pump. The results obtained are summarized in

Table 3

Interferences study. Results expressed as the relative deviation from the absorbance value of a 20 $\mu\text{g/L}^{-1}$ titanium standard solution.

Species tested	Concentration ($\mu\text{g/L}$)	Relative deviation (%)
Iron ^a	20	+5.4
Iron ^b	2000	-2.4
Aluminium	100	+4.5
Copper	500	+5.6
Lead	1000	+4.9
Vanadium	500	+5.6
Chromium	200	+2.9
Fluoride	200	+3.9

^a Without ascorbic acid.

^b With ascorbic acid.

Table 1 and represent the mean of twenty replicates (five replicates for each flow rate and volume).

As referred above, the sample volume introduced in the system was controlled by the length of the tube placed between the two commutation valves (the "sample loop"—SL), since in preliminary experiments an improvement in the repeatability was verified using this sampling mode.

The SL volume was varied within 100 and 400 μL and 200 μL was the selected value. The reaction coil length was studied in the range of 10–150 cm and 50 cm was the length that allowed better sensitivity. The flow rate was varied within 0.5 and 5 mL/min in all the steps of the analytical cycle (Table 2). In the first and fourth steps, the sensitivity and the blank values were independent of the flow rate, therefore 5 mL/min was used in order to maximize the sampling rate. In the second and third steps, the sensitivity and the blank values increased for lower flow rates. The best compromise between sensitivity and blank values was achieved at 1 mL/min.

The analytical wavelength was evaluated in the range from 415 to 445 nm and 425 nm allowed the best compromise regarding sensitivity and low blank values.

Following this study, reagent volumes from 60 to 200 μL were tested and 100 μL (corresponding to 5 micro-pump pulses) were chosen as this volume provided a better repeatability (RSD < 3%). The chemical parameters evaluated in the optimization of the methodology included the concentration of the colour reagent (chromotropic acid) and reducing agent (ascorbic acid), and the concentration and pH of the buffer solution (sodium acetate/acetic acid). Firstly, the reagent concentration was studied in the range of 1.25×10^{-4} to 2.5×10^{-3} mol/L and the best sensitivity with a relatively low blank value (0.030) was obtained for 1.25×10^{-3} mol/L. High blank values shorten the application range of the methodology since CCD spectrophotometers performance deteriorates for absorbance values over 1.8 [31].

The concentration (in the range of 0.05–1 mol/L) and the pH (in the range of 4.2–5.0) of the acetate buffer were then studied. The best sensitivity was obtained for a concentration of 0.2 mol/L and a pH of 4.6, and these values were used in subsequent experiments.

Finally, the ascorbic acid concentration was evaluated. Ascorbic acid was necessary to assure the complete reduction of iron(III) to iron(II), since iron(III) interferes with titanium determination (Table 3). The ascorbic acid concentration was varied between 1 and 4% (w/v) and a concentration of 2% showed to guarantee the total iron(III) reduction at concentrations up to 2 mg/L.

3.2. Interference studies

The interference of several ions on the determination of titanium was tested. Solutions with a fixed concentration of titanium (20 $\mu\text{g/L}$) and increasing concentrations of the tested ions were prepared. Ions causing deviations higher than 5% in the absorbance value of the pure 20 $\mu\text{g/L}$ titanium standard solution, were consid-

Table 4

Figures of merit of the developed methodology.

Parameters	Values
Limit of detection ($\mu\text{g/L}$)	0.4
Limit of quantification ($\mu\text{g/L}$)	0.8
Analytical working range ($\mu\text{g/L}$)	Up to 100
Analytical throughput (/h)	46
Reagent consumption per assay (μmol)	
Chromotropic acid	0.125
Ascorbic acid	5.68
Sodium acetate	20
Acetic acid	20
Waste produced per assay (mL)	5.8

ered as interferents. The ions studied were Fe(III), Pb(II), Al(III), F⁻, Cu(II), V(V) and Cr(VI) at concentrations of 20, 40, 100, 200, 500, 1000 and 2000 $\mu\text{g/L}$, respectively (Table 3). The major interference was from Fe(III) at the same level of titanium. This interference was minimized by the addition of ascorbic acid to the colour reagent as can be seen in Table 3. The other main interferences were from aluminium at a concentration five times higher than titanium and fluorine and chromium at a concentration ten times higher than titanium.

3.3. Figures of merit

All the analytical performance characteristics obtained for titanium determination are summarized in Table 4. The limit of detection (LOD) and limit of quantification (LOQ) were calculated as the concentration corresponding to three and ten times the standard deviation of the blank, respectively [32].

3.4. Application to water samples

Concluded the optimization of all of the physical and chemical parameters, the proposed analytical procedure was applied to different types of water in order to assess its accuracy.

Initially, recovery tests were carried out on different types of water samples: surface (sea and river) and ground (well and mine) waters. Table 5 summarizes the results obtained for three levels of analyte addition (4, 10 and 20 $\mu\text{g/L}$). They suggest that the matrix of water samples does not appreciably interfere in the determination of titanium.

Chromotropic acid reacts with Ti(IV). However, TiO₂ is the most frequent form of the analyte present in environmental and cosmetic samples. Therefore, a comparison study using similar concentrations of standards of Ti(IV) (prepared both from the commercial standard solution and from the dissolved/digested TiO₂) was performed. The linear relationship between the molar concentration of Ti ($C_{\text{Ti(IV)}}$; C_{TiO_2}) obtained using Ti(IV) standards or TiO₂ standards was $\text{Abs}_{425\text{ nm}} = 0.0121 (\pm 2 \times 10^{-4}) C_{\text{Ti(IV)}} + 0.0026 (\pm 0.0040)$ and

Table 5

Recovery tests. Results (%) obtained in different types of water for three different addition levels.

Water types	Concentration added		
	4 $\mu\text{g/L}$	10 $\mu\text{g/L}$	20 $\mu\text{g/L}$
Well	95 \pm 3	106 \pm 1	105 \pm 1
Polluted river not filtered	89 \pm 2	94 \pm 1	98 \pm 2
Sea	92 \pm 1	106 \pm 3	106 \pm 2
Sea	96 \pm 8	102 \pm 6	96 \pm 4
Estuarine	88 \pm 3	102 \pm 1	107 \pm 1
Mine	96 \pm 3	94 \pm 1	99 \pm 1
Polluted river	90 \pm 4	96 \pm 1	98 \pm 1
Polluted river	91 \pm 2	93 \pm 2	97 \pm 1

Mean and standard deviation of 5 replicates.

Table 6

Comparison of the results obtained in the determination of TiO₂ in five commercial sunscreens products.

Sample	TiO ₂ % (w/w)	
	Developed method ^a	ICP-MS ^b
1	2.33 ± 0.01	2.29 ± 0.13
2	1.77 ± 0.01	1.70 ± 0.11
3	1.66 ± 0.01	1.65 ± 0.10
4	2.29 ± 0.02	2.33 ± 0.07
5	1.40 ± 0.01	1.35 ± 0.12

^a Mean and standard deviation of 5 replicate analysis of the same digestion solution.

^b Mean and standard deviation of 2 replicate analysis of the same digestion solution.

Table 7

Recovery tests. Results obtained with a certified lake sediment sample.

Assay number	Expected Ti concentration (µg/L)	Recovery (%) ^a
1	41.1	97 ± 1
2	29.7	105 ± 1
3	18.9	97 ± 1
4	26.2	108 ± 1
5	25.5	92 ± 1
6	37.6	93 ± 1

^a Mean and standard deviation of 5 replicates.

$Abs_{425\text{ nm}} = 0.0122 (\pm 1 \times 10^{-4}) C_{TiO_2} + 0.0052 (\pm 0.0011)$, respectively. The equation parameters obtained for the two standard curves show no significant difference (standard errors on the estimated parameters are indicated between brackets). These results demonstrate that the developed method is applicable to the determination of Ti in both chemical forms.

3.5. Application to commercial sunscreens

Although the primary objective of the proposed method is to determine Ti in waters, it was also applied to different commercial sunscreen samples, previously submitted to a microwave acid digestion. To assess the quality of the results, they were compared with those obtained by ICP-MS (Table 6). The calculated *t*-values were below the critical *t*-value (6.31) and the linear regression parameters showed no significant difference between the results obtained by the developed system (C_{MPFS}) and by the alternative procedure, $C_{MPFS} = 0.94 (\pm 0.15) C_{ICP-MS} + 0.13 (\pm 0.29)$, where the values between brackets are the limits of the 95% confidence intervals.

3.6. Application to lake sediment

The developed analytical procedure was also applied to one reference lake sediment material (IAEA-SL-1) with a certified value of 5170 ± 430 mg Ti per kg of sediment. When analysed by the developed procedure the result obtained was 5155 ± 113 mg/kg. This result corresponds to the average of 5 assays and the half width of the 95% confidence interval. The solution obtained in the sample digestion was diluted 1000 times in order to adjust its concentration to the linear response range of the MPFS analytical procedure. The result shows a good accuracy of the developed procedure.

Additionally, recovery tests were performed on the certified lake sediment sample, to which TiO₂ nanoparticles were added in their solid form. The recovery results, presented in Table 7, are relative to the expected concentrations in the digests after spiking the sediment sample.

4. Conclusions

This work presents a reliable spectrophotometric determination of titanium at low levels applicable to different water samples, digested commercial sunscreens and sediments. The proposed methodology is relatively simple and inexpensive, with a good analytical throughput and low reagent consumption/effluent production (green chemistry approach). The employment of a LWCC allows the determination of Ti at very low levels without using a preconcentration step.

When compared to previous works, this analytical procedure allows titanium determinations in different types of samples with a low detection limit, low reagent consumption and high throughput.

Acknowledgements

The authors thank Fundação para a Ciência e a Tecnologia (FCT) for financial support through Projects PTDC/AMB/64441/2006 and PTDC/AAC-AMB/104882/2008. Ricardo Páscoa acknowledges financial support from FCT through the grant SFRH/BD/30621/2006. I.V. Tóth thanks FSE and Ministério da Ciência, Tecnologia e Ensino Superior (MCTES) for the financial support through the POPH-QREN program.

Appendix A. Supplementary data

Supplementary data associated with this article can be found, in the online version, at doi:10.1016/j.snb.2011.03.025.

References

- [1] S.A. Skrabal, C.M. Terry, Distributions of dissolved titanium in porewaters of estuarine and coastal marine sediments, *Mar. Chem.* 77 (2002) 109–122.
- [2] R.E. Santelli, R.C.S. Araujo, Spectrophotometric flow-injection determination of titanium in rocks, *Analyst* 117 (1992) 1519–1521.
- [3] S.A. Skrabal, Distributions of dissolved titanium in Chesapeake Bay and the Amazon river estuary, *Geochim. Cosmochim. Acta* 59 (1995) 2449–2458.
- [4] A.N. Shipway, E. Katz, I. Willner, Nanoparticle arrays on surfaces for electronic, optical and sensor applications, *Chem. Phys. Chem.* 1 (2000) 18–52.
- [5] S.B. Lovern, R. Klaper, *Daphnia magna* mortality when exposed to titanium dioxide and fullerene (C₆₀) nanoparticles, *Environ. Toxicol. Chem.* 25 (2006) 1132–1137.
- [6] K. Hund-Rinke, M. Simon, Ecotoxic effect of photocatalytic active nanoparticles (TiO₂) on algae and daphnids, *Environ. Sci. Pollut. Res.* 13 (2006) 225–232.
- [7] G. Federici, B.J. Shaw, R.D. Handy, Toxicity of titanium dioxide nanoparticles to rainbow trout, (*Oncorhynchus mykiss*): gill injury, oxidative stress, and other physiological effects, *Aquat. Toxicol.* 84 (2007) 415–430.
- [8] F.S. Kika, D.G. Themelis, Selective stopped-flow sequential injection method for the spectrophotometric determination of titanium in dental implant and natural Moroccan phosphate rock, *Talanta* 71 (2007) 1405–1410.
- [9] R. Cai, Y. Kubota, T. Shuin, H. Sakai, K. Hashimoto, A. Fujishima, Introduction of cytotoxicity by photoexcited TiO₂ particles, *Cancer Res.* 52 (1992) 2346–2348.
- [10] T. Masciongioli, W.-X. Zhang, Environmental technologies at nanoscale, *Environ. Sci. Technol.* 37 (2003) 102A–108A.
- [11] R.A. Caruso, M. Antonietti, M. Giersig, H.P. Hentze, J. Jia, Modification of TiO₂ network structures using a polymer gel coating technique, *Chem. Mater.* 13 (2001) 1114–1123.
- [12] S.B. Lovern, J.R. Stricker, R. Klaper, *Daphnia magna* when exposed to nanoparticle suspensions (titanium dioxide, nano-C₆₀, and C₆₀HxC₇₀Hx), *Environ. Sci. Technol.* 41 (2007) 4465–4470.
- [13] G. Oberdörster, E. Oberdörster, J. Oberdörster, Nanotoxicology: an emerging discipline evolving from studies of ultrafine particles, *Environ. Health Perspect.* 113 (2005) 823–839.
- [14] S.-W. Lee, S.-M. Kim, S.-M.J. Choi, Genotoxicity and ecotoxicity assays using the freshwater crustacean *Daphnia magna* and the larva of the aquatic midge *Chironomus riparius* to screen the ecological risks of nanoparticle exposure, *Environ. Toxicol. Pharmacol.* 28 (2009) 86–91.
- [15] A. Kahru, H.-C. Dubourguier, From ecotoxicology to nanoecotoxicology, *Toxicology* 269 (2010) 105–119.
- [16] EC (European Commission) Technical Guidance Document in Support of Commission Directive 93/67/EEC on Risk Assessment for New Notified Substances. Part II. Environmental Risk Assessment. Office for Official Publications of the European Communities, Luxembourg, 2003.
- [17] X. Zhang, S. Hongwen, Z. Zhang, Q. Niu, Y. Chen, J.C. Crittenden, Enhanced bioaccumulation of cadmium in carp in the presence of titanium dioxide nanoparticles, *Chemosphere* 67 (2007) 160–166.

- [18] C.S. Ramsden, T.J. Smith, B.J. Shaw, R.D. Handy, Dietary exposure to titanium dioxide nanoparticles in rainbow trout, (*Oncorhynchus mykiss*): no effect on growth, but subtle biochemical disturbances in the brain, *Ecotoxicology* 18 (2009) 939–951.
- [19] M.A. Segundo, A.O.S.S. Rangel, Flow analysis: a critical view of its evolution and perspectives, *J. Flow Inj. Anal.* 19 (2002) 3–8.
- [20] V. Cerdà, R. Forteza, J.M. Estela, Potential of multisyringe flow-based multicommutated systems, *Anal. Chim. Acta* 600 (2007) 35–45.
- [21] M. Munoz, J. Alonso, J. Bartolí, M. Valiente, Automated spectrophotometric determination of titanium(IV) in water and brines by flow injection analysis based on its reaction with hydrogen peroxide, *Analyst* 115 (1990) 315–318.
- [22] S. Kozuka, K. Saito, K. Oguma, R. Kuroda, Simultaneous determination of trace amounts of iron(III) and titanium(IV) by flow injection with spectrophotometric detection, *Analyst* 115 (1990) 431–434.
- [23] A.A. Alwarthan, A. Townshend, Chemiluminescence determination of iron(II) and titanium(III) by flow-injection analysis based on reactions with and without luminol, *Anal. Chim. Acta* 196 (1987) 135–140.
- [24] S. Hirata, Y. Umezaki, M. Ikeda, Determination of chromium(III), titanium, vanadium, iron(III), and aluminium by inductively coupled plasma atomic emission-spectrophotometry with an online preconcentration ion-exchange column, *Anal. Chem.* 58 (1986) 2602–2606.
- [25] K.L. Yang, T.J. Jiang, J. Hwang, Determination of titanium and vanadium in water samples by inductively coupled plasma mass spectrometry with on-line preconcentration, *J. Anal. Atom. Spectrom.* 11 (1996) 139–143.
- [26] M.J. Ruedas-Rama, A. Ruiz-Medina, A. Molina-Díaz, Resolution of biparametric mixtures using bead injection spectroscopic flow-through renewable surface sensors, *Anal. Sci.* 21 (2005) 1079–1084.
- [27] K. Fuwa, W. Lei, K. Fujiwara, Colorimetry with a total-reflection long capillary cell, *Anal. Chem.* 56 (1984) 1640–1644.
- [28] R.N.M.J. Páscoa, I.V. Tóth, A.O.S.S. Rangel, Sequential injection trace determination of iron in natural waters using a long-pathlength liquid core waveguide and different spectrophotometric chemistries, *Limnol. Oceanogr.: Methods* 7 (2009) 795–802.
- [29] R.A.S. Lapa, J.L.F.C. Lima, B.F. Reis, J.L.M. Santos, E.A.G. Zagatto, Multi-pumping in flow analysis: concepts, instrumentation, potentialities, *Anal. Chim. Acta* 466 (2002) 125–132.
- [30] E.A.G. Zagatto, M.A.Z. Arruda, A.O. Jacintho, I.L. Mattos, Compensation of the Schlieren effect in flow injection analysis by using dual wavelength spectrophotometry, *Anal. Chim. Acta* 234 (1990) 153–160.
- [31] J. Galbám, S. Marcos, I. Sanz, C. Ubide, J. Zuriarrain, CCD detectors for molecular absorption spectrophotometry. A theoretical and experimental study on characteristics and performance, *Analyst* 135 (2010) 564–569.
- [32] IUPAC-International Union of Pure and Applied Chemistry, Analytical Chemistry Division, Commission on spectrochemical and other optical procedures

for analysis. Nomenclature, symbols, units and their usage in spectrochemical analysis. II. Data interpretation (Rules approved 1975), *Pure Appl. Chem.* 45 (1976) 99–103.

Biographies

Ricardo N.M.J. Páscoa is a PhD student at Universidade Católica Portuguesa-Escola Superior de Biotecnologia, Porto. He has MSc degree from the Faculty of Pharmacy of the University of Porto on Environmental Analytical Chemistry (2006) and a university degree on Microbiology from Universidade Católica Portuguesa-Escola Superior de Biotecnologia. He has been working with flow analysis methodologies in his PhD and worked with chemometrics in his MSc degree. He is the first author of a few number of papers in both fields.

Idikó V. Tóth is an assistant researcher at the Requimte, Faculty of Pharmacy at the University of Porto. She received her university (1993) degree in Food Engineering from the University of Hortofruticulture and Food Industry (Budapest), and a PhD (2001) in Biotechnology, speciality in Chemistry, from the Universidade Católica Portuguesa-Escola Superior de Biotecnologia (Porto). She is a co-author of 30 papers in international peer reviewed journals. Her current research interests include chemical sensors for emerging environmental contaminants and laboratory automation.

Agostinho A. Almeida is an auxiliary professor at the Faculty of Pharmacy of the University of Porto. After his graduate studies in Pharmaceutical Sciences, he received his PhD degree in Analytical Chemistry from the University of Porto in 2000. His current research interests are the development and validation of analytical methodologies for trace element analysis in clinical, toxicological, forensic and environmental fields, particularly by using graphite furnace atomic absorption spectrometry (GFAAS) and inductively coupled plasma-mass spectrometry (ICP-MS) techniques.

António O.S.S. Rangel is associate professor at the Universidade Católica Portuguesa-Escola Superior de Biotecnologia, Porto. He got his degree in Chemistry from University of Porto and his PhD degree in Biotechnology (specialization in Chemistry) from Universidade Católica Portuguesa-Escola Superior de Biotecnologia. He co-authored more than 100 papers in international journals, he is member of the Editorial Advisory Board of *Analytica Chimica Acta* and is President of the Analytical Chemistry Division of the Portuguese Chemical Society. His research interests are focused on the development of flow methods for the automation and miniaturization of (bio)chemical assays, with applications in the food and environmental sectors.