

2-1974

Macromodular Computer Design, Part 2, Volume 01, General Standards and System Maintenance

Computer Systems Laboratory, Washington University

Follow this and additional works at: http://digitalcommons.wustl.edu/bcl_techreports

Recommended Citation

Computer Systems Laboratory, Washington University, "Macromodular Computer Design, Part 2, Volume 01, General Standards and System Maintenance" (1974). *Technical Reports*. Paper 6.
http://digitalcommons.wustl.edu/bcl_techreports/6

This Technical Report is brought to you for free and open access by the Institute for Biomedical Computing at Digital Commons@Becker. It has been accepted for inclusion in Technical Reports by an authorized administrator of Digital Commons@Becker. For more information, please contact engeszer@wustl.edu.

MACROMODULAR
COMPUTER DESIGN
PART 2
MANUFACTURING DESCRIPTION

VOLUME I

GENERAL STANDARDS AND SYSTEM MAINTENANCE

Technical Report No. 30

FINAL REPORT - FEBRUARY, 1974

CONTRACT SD-302 (ARPA)

COMPUTER SYSTEMS LABORATORY

WASHINGTON UNIVERSITY

ST. LOUIS, MISSOURI

MACROMODULAR COMPUTER DESIGN
FINAL REPORT - CONTRACT SD-302
FEBRUARY, 1974

Technical Report No. 30

PART 2 - MANUFACTURING DESCRIPTION
VOL. I-GENERAL STANDARDS AND SYSTEM MAINTENANCE

This work has been supported by the Advanced Research Projects Agency of the Department of Defense under Contract SD-302 and by the Division of Research Facilities and Resources of the National Institutes of Health under Grant RR-00396.

The views and conclusions contained in this document are those of the authors and should not be interpreted as necessarily representing the official policies either expressed or implied, of the Advanced Research Projects Agency or the U.S. Government.

Computer Systems Laboratory
Washington University
St. Louis, Missouri

ABSTRACT

Metal finishes, assembly specifications for printed circuit boards, standards for manufacture of printed circuit boards, description of electrical and mechanical properties of macromodular data and control cables, manufacturing specification of Sprague LTN-2 and LTN-3 resistor networks, description and data sheets of BERNE, Inc. CTS 750 cermer resistor networks, wiring paths and pictorial assembly drawings of types of faceplate subassemblies are given.

INDEX

GENERAL STANDARDS

PAGES 010-1 thru 010-58

SYSTEM MAINTENANCE

PAGES 012-1 thru 012-60

COMPUTER SYSTEMS LABORATORY
WASHINGTON UNIVERSITY

010

GENERAL STANDARDS

PAGE	TITLE	CHANGE
010-1, 1A	TITLE PAGE	N
010-2X 010-3X	MACROMODULAR CONTROL CABLE CAS-5X (OBSOLETE)	
010-4X 010-5X	MACROMODULAR DATA CABLE CAS-6X (OBSOLETE)	
010-10 010-11	MF-1, MF-2 & MF-3 METAL FINISHES	F, I
010-12 thru 010-16	PC-1 PRINTED CIRCUIT STANDARDS	A,D,K,M
010-17 010-18	SPRAGUE LTN-2 NETWORK	
010-19 thru 010-23	SPRAGUE LTN-3 NETWORK	G
010-24 thru 010-34	GENERAL PRINTED CIRCUIT BOARD ASSEMBLY SPECIFICATIONS	B, E
010-35 thru 010-40	ASSEMBLY SPECIFICATION FOR POWER CONVERTER BOARDS	B
010-41 THRU 010-46	MACROMODULAR DATA CABLE CAS-6	C
010-47 010-48	MACROMODULAR CONTROL CABLE CAS-7	H
010-49 010-50	INTERLOCK NETWORK	L
010-51 010-52	CTS 750 SERIES DATA SHEET	L

CHG.	E.C.O.	DATE	APPR	CHG.	E.C.O.	DATE	APPR	CHG.	E.C.O.	DATE	APPR.
ISSUE	-	1-7-71	<i>DCJ</i>	E	0230	11-11-71	<i>MRK</i>	J	0265	6-16-72	<i>DCJ</i>
A	0171	4-19-71	<i>carh</i>	F	0231	11-16-71	<i>RJA</i>	K	0266	7-5-72	<i>DCJ</i>
B	0178	5-10-71	<i>cem</i>	G	0243	1-6-72	<i>DCJ</i>	L	0287	3-3-73	<i>DCJ</i>
C	0222	7-29-71	<i>DCJ</i>	H	0246	1-11-72	<i>DCJ</i>	M	0289	3-22-73	<i>DCJ</i>
D	0225	9-8-71	<i>MRK</i>	I	0262	5-2-72	<i>RJA</i>	N	0296	9-7-73	<i>MRK</i>

COMPUTER SYSTEMS LABORATORY

WASHINGTON UNIVERSITY



GENERAL STANDARDS (CONT.)

PAGE	TITLE	CHANGE
010-53 THRU 010-58	MULTI-LAYER P.C. BOARD SPECIFICATION PC-2	N

CHG.	E.C.O.	DATE	APPR	CHG.	E.C.O.	DATE	APPR	CHG.	E.C.O.	DATE	APPR.
N	0296	9-7-73	<i>JUR</i>								

MACROMODULAR SYSTEMS PROJECT

METAL FINISHES
Specification MF-1

I. Introduction

The most prevalent structural material in the Macromodular Computer System is aluminum, in several popular alloys. This specification describes a decorative and protective finish, and gives an outline of the processing steps required.

II. Decorative Finish

This document is a performance specification rather than a specific manufacturing recipe. The general description which follows gives an outline of the process; but due to the many variables in the metal finishing industry, samples must be provided for the approval of CSL by any new vendor or by any vendor who wishes to change an established processing sequence.

The desired finish is a clear anodize coating of low reflectance. All surfaces shall be smooth (32 microinch or less roughness) and have a uniform matte finish. In addition, the metal finish procedure must not alter in any way the physical size of a component such that the manufacturing tolerances are exceeded. In the event that this should occur manufacturer and metal finisher must decide on a course of action to correct this problem. A successful process has been:

1. Glass Ball Peen
2. Caustic Etch
3. Sulfuric Acid Anodize

Each of these steps requires some clarification, based upon painful past experience.

III. Glass Ball Peening

Glass Ball Peening is frequently used for deburring and for stress relief, but some adjustments must be made to achieve the MF-1 finish. The processor should use the smallest available glass ball, and a lower air pressure than for stress relieving.

Thin section panels must be peened on both sides, and care must be taken to achieve an even surface. Parts shall be supported by simple jigs to prevent deformation when necessary.

IV. Caustic Etch

After the aluminum parts are completely cleaned of glass residue, they are given a light caustic etch. The strength and period shall be controlled to bring out the grain in rolled materials. In no case shall the parts be etched long enough to remove or enlarge holes.

V. Sulfuric Acid Anodize

The aluminum parts shall be anodized by a process similar to Alcoa Alumilite 201. The coating thickness shall be approximately 0.0002 inches.

The color of the coating may vary over the several alloys used. The color is not as important as the freedom from blemishes and the uniformity of the matte finish.

CHG.	E.C.O.	DATE	APPR.
ISSUE	-	1-7-71	JCL
F	0231	11-16-71	RJA
I	0262	5-2-72	RJA

VI. Qualification

Any new vendor will be given samples of properly finished articles. The vendor must then produce samples in his own process and return them to CSL for approval. This approval must be obtained before any substantial runs are made, as parts will be rejected for poor finish.

Specification MF-2

This specification, MF-2, is essentially a black anodize finish for various aluminum parts in the macromodular system requiring a decorative and protective finish. As such, proper care in preparation and execution of the finishing process must be exercised in order that a uniform surface finish results from the process. This will usually require caustic etch to remove any surface residues that may interfere with achieving uniform finishes. In no case should etch continue long enough to seriously alter specified dimensional accuracy of parts. In the event that this should occur vendor and metal finisher must decide on a course of action to correct this problem.

This document is not intended to indicate a specific anodize procedure. Due to the many variables in the metal finishing industry the vendor must produce samples in his own process and return them to CSL for approval. This approval must be obtained before any production runs are made as parts will be rejected for poor finish. Samples of properly finished articles will be provided by CSL upon request.

Specification MF-3

The intent of this specification, MF-3, is to caution the vendor against surface damage to finished parts while undergoing assembly. As care has been taken to achieve a decorative and protective finish for certain parts in the macromodular system it is essential that similar care be exercised during operations of assembly involving riveting, insertion of screws, fitting of parts or any other procedure which may jeopardize the cosmetic and protective qualities of finishes.

Before production assembly of parts begins the vendor must produce samples of completed assemblies and submit them to CSL for approval. This approval must be granted as parts will be rejected for damage in assembly.

CHG.	E.C.O.	DATE	APPR.
1	0262	5-2-72	RJA

Two-Sided Plated Through Circuit Board

General Specification PC-1

I. Scope:

This document provides general specifications for two-sided printed circuit boards with solder plated plated-through holes for use in macromodule subassemblies. These general specifications apply to all circuit board types unless specific exception is made within the documents describing a particular circuit board type.

II. Material:

Material is to be type FR-4 glass epoxy laminate with 1 oz. copper on both sides. Initial laminate thickness before plating and etching is to be 0.0625 + or - 0.005 inches.

III. Plating:

Finished thickness of copper on conductors, pads and terminal areas shall be from 0.002 to 0.003 inches. Thickness in holes is given below. A layer of lead-tin alloy shall be plated to a depth of 0.0003 to 0.0007 over all copper surfaces. All circuit boards shall have the solder plating on both surfaces reflowed by means of a hot peanut oil, hydro-squeegee, or similar process in order to melt back plating overhang. Final plated surface shall be free of contamination and shall be free from defects that may be detrimental to good soldering.

When areas of gold plating are specified (such as contact fingers), there shall be a minimum of 0.000050 inches of gold over a minimum of 0.000150 inches of nickel. The gold shall be free of porosity or nodules.

CHG.	E.C.O.	DATE	APPR.
K	0266	5-7-72	<i>DCJ</i>
M	0289	3-22-73	<i>DCJ</i>

CHG.	E.C.O.	DATE	APPR.
ISSUE	-	11-23-70	<i>DCJ</i>
A	0138	12-29-70	<i>DCJ</i>
B	0144	1-7-71	<i>DCJ</i>
A	0171	4-19-71	<i>CEH</i>
D	0225	9-8-71	<i>NTK</i>
E	0265	6-16-72	<i>DCJ</i>

IV. Etching:

Areas not intended to have conductor shall be etched free of any copper residue. Undercutting should not exceed copper thickness. Undercutting should not produce splinters along conductor edges.

V. Dimensional tolerances on final etch pattern:

A. Conductor paths corresponding to 0.050 tape in the 4:1 artwork shall have a minimum width of 0.009 inch and a maximum width of 0.015 inch. Width as narrow as 0.005 inch is acceptable for a distance not exceeding 0.020 inch along a line, but not in the area where a line joins a pad. No more than five such narrowings are allowable on one surface of any circuit board.

B. Width greater than 0.015 inch shall be acceptable if minimum clearances are maintained between conducting paths and providing that no more than 10% of the length of a given line exceeds a width of 0.015 inch.

C. A minimum clearance of 0.007 inch between adjacent conducting areas shall be maintained.

VI. Plated-through holes:

A. Four plated-through hole types are general used. Additional plated-through and non-plated-through hole types may be specified for individual board designs.

1. Type "A" holes, for special components, are plated through with a finished diameter after copper and solder plating of 0.045 to 0.051 inches.

2. Type "B" holes, for male and female amp modu connectors and component leads, are plated through with a finished diameter after copper and solder plating of 0.033 to 0.037 inches.

3. Type "C" holes, for special components, are plated through with a finished diameter after copper and solder plating of 0.069 to 0.077 inches.

4. Type "D" holes, for special components, are plated through with a finished diameter after copper and solder plating of 0.057 and 0.065 inches.

5. Type "E" holes, for special components, are plated through with a finished diameter after copper and solder plating of 0.142 to 0.152 inches.

B. Holes should be plated through unless otherwise specified. Finished Plating thickness of copper on the wall of the hole shall be a minimum average of 0.001 inch as measured at three points at least 0.010 inches apart. No single measurements shall be less than 70% of this minimum. Pinholes, voids, pits and projections are excluded from these measurements.

C. No more than three voids per hole are permitted. Total area of the voids shall not exceed 10% of the total wall area. Largest dimension not to exceed 25% of the core circumference or 25% of the thickness of the board.

D. No plated hole shall have voids or pits at the junction of the hole wall and terminal area to a depth of 1 1/2 times the total copper thickness on the surface.

E. Hole diameter tolerances given apply prior to the reflow operation. Reduction of hole diameter of 15 percent or less during reflow is acceptable.

VII. Unplated holes:

Registration and reference holes are not plated through, and generally are 0.093 + or -0.003 inches unless otherwise shown on individual board documents. Additional types may be specified for individual board designs.

VIII. Hole positioning:

A. Drilling coordinates may be referenced either to artwork or to registration holes or both on a specific circuit board. This is designated separately for each circuit board type.

B. All holes of a given size are to be registered to within ± 0.003 inches of true position with respect to other holes of the same size.

IX. Artwork:

A. Artwork for circuit boards is prepared as follows: Master Pad Patterns are taped at 4:1 on 7 mil mylar on an etched glass grid plate with 0.050 spacing between grid lines. Cronaflex prints made from the Master Pad Pattern are used for taping the artwork for both sides of the circuit board to ensure registration.

B. Minimum clearance of 0.045 is maintained between taped regions that are not in contact. This minimum clearance generally occurs only at the nearest approach of a printed circuit line to a pad.

C. Minimum pad size of 0.250 inch O.D.

D. No conducting paths are taped with tape less than 0.050 inches wide.

E. Artwork is generally supplied in the form of 4:1 Cronaflex contact prints of the taped artwork. The Cronaflex print may contain small amounts of tape used for adjustments or corrections. These Cronaflex prints should be returned to Washington University following their use in preparing reductions.

X. Artwork Identification:

A. All artwork is identified by a number appearing on the artwork within the region that will be reproduced on the circuit board. Artwork for the two sides of a circuit board bears an identical number, typically in the form XXX NNNN-N, where X designates letters A through Z and N designates numbers 0 through 9. All letters and numbers of this group are significant and should correspond exactly on the artwork for the two sides of a specific board. Two additional letters may follow the above identifying number. They are for reference only and are not a part of the artwork identification number.

B. Numbers are to be reproduced so that they are right-reading on the completed circuit board.

XI. Board finish:

When specified, the component side of the circuit board will have a screened pattern for component identification applied. The material applied shall be non-conductive, permanent, and resistant to materials and procedures used in board assembly, inspection, and cleaning.

Delivered circuit boards shall be free of scratches, abrasions, other physical damage, and contamination by foreign substances or residues. Any damage that exposes copper underlying solder plating is cause for board rejection.

XII. Board packaging:

Circuit boards shall be shipped in individual plastic covers to prevent contact between the surfaces of adjoining circuit boards and to protect board from abrasion. They shall be secured so as to prevent slipping against one another during shipment.

MANUFACTURING SPECIFICATION
LINE TERMINATION NETWORK LTN-2

July 15, 1968

Revised January 4, 1971

INTRODUCTION:

This specification describes a four resistor network which will be used to terminate high speed pulse transmission lines. The network shall be manufactured in the Sprague Metanet technology or equivalent.

ELECTRICAL CHARACTERISTICS:

The network shall consist of four 130 ohm $\pm 1\%$ resistors with a power rating of 120 milliwatts. The resistors shall have a temperature coefficient of ± 500 ppm/ $^{\circ}\text{C}$ or less over an ambient temperature range of -55°C to $+85^{\circ}\text{C}$.

MECHANICAL CHARACTERISTICS:

The four resistors shall be packages in an 8 lead ceramic package with maximum overall dimensions of 0.125" x 0.350" x 0.900". The leads shall be #24 AWG tinned copper wire, spaced at multiples of 0.100" ± 0.005 ". The leads shall be 0.5" minimum length.

GENERAL:

An electrical schematic and a package outline sketch are included with this specification. The package is to be identified with the marking LTN-2, and the leads are to be numbered 1 through 8.

RESISTOR CHARACTERISTICS:

1. Power Rating: The power rating of each resistor is as specified and is based on continuous operation up to 85°C .

CHG.	E.C.O.	DATE	APPR.
ISSUE	-	1-7-71	<i>SCJ</i>

ELECTRICAL SCHEMATIC

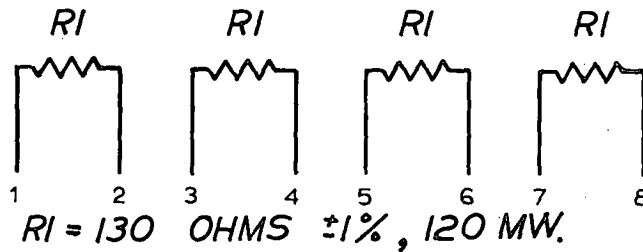

PHYSICAL DIMENSIONS

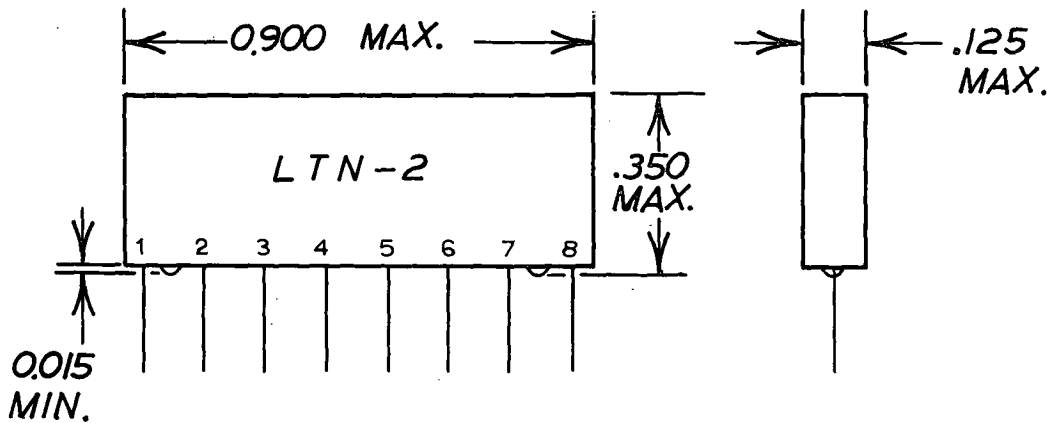

COMPUTER SYSTEMS LABORATORY WASHINGTON UNIVERSITY ST. LOUIS, MISSOURI			MACROMODULAR PROJECT			
			TITLE CASE DIMENSIONS AND INTERNAL CONNECTIONS			
			APPROVED		ENG GCJ	DRAWING NO. 010-18
			BY <i>gcj</i>	FOR PROD.	DATE 1-7-71	DRAWN BY DHO
CHANGE NO.	DATE	DESCRIPTION	CHECKED GCJ		DATE 1-6-71	
ISSUE 1-7-71	<i>gcj</i>					

October 13, 1970

Manufacturing Specification

LTN-3 Terminating Network

Introduction:

This specification describes a ceramic base resistor-capacitor network designed in the Sprague "Bulplate" technology. The general specifications and descriptions are contained in Sprague Engineering Bulletin 6600A, July 1966.

Resistors:

The resistors are the standard thick film resistors of the Bulplate series. There are two values, 1290 ohms and 488 ohms, both at a tolerance of plus or minus 20 per cent and a power rating of 1/5 watt.

Capacitors:

The three capacitors are intended to bypass interfering signals with frequencies as low as 10 megahertz. The capacitors should be as large as possible while maintaining minimum seated height and a voltage rating of 10 volts. The capacitors are shown as being distributed on the schematic, but may be discrete chips if so specified by Sprague. A nominal value of 30 pfd is considered adequate.

General:

The maximum voltage which will be applied to this network in service is 5.2 volts.

The case shall be marked with the terminal numbers as shown on the outline drawing, and the designation LTN-3.

CHG.	E.C.O.	DATE	APPR.
ISSUE	-	1-7-71	<i>rcj</i>
G	0243	1-6-72	<i>rcj</i>

2. Resistance: The resistance values shall be within the specified tolerances for each resistor. Measurements shall be made at 3VDC and 25°C or else referred to measurements at that voltage and temperature.

Note: Resistor elements in series with other circuit elements may not be directly measurable. In such cases, impedance measurements may be necessary. Also some circuit configurations may include closed resistance loops which require extra calculations to determine individual resistant values.

3. Voltage Rating: The maximum voltage rating on any resistor shall be determined by the maximum power rating specified.
4. Short Time Overload: All resistors shall withstand for five (5) seconds a voltage equal to 2.5 times the rated continuous voltage without exhibiting a permanent change of more than $\pm 1\%$ of the resistance value.
5. Temperature Coefficient: The temperature coefficient of all resistors shall be within ± 500 ppm/°C for operation in temperature range of -55°C to +85°C.
6. Humidity Resistance: After exposure for a period of 250 hours to an atmosphere of 95% relative humidity at a temperature of 65°C and one hour exposure of 40% maximum relative humidity at 25°C, the maximum resistance change shall be 1.0%.
No more than one (1) failure shall be permitted in twelve (12) units tested.
7. Life Test: When these resistors are operated at rated wattage and 85°C for 1,000 hours, the maximum change in resistance shall be less than $\pm 1\%$ for all resistance values.
No more than one (1) failure shall be permitted in twelve (12) units tested.

8. Temperature Cycling: Resistors shall show no mechanical damage nor change of resistance greater than $\pm 1\%$ when subject to 5 temperature cycles from $+25^{\circ}\text{C}$ to -55°C to $+85^{\circ}\text{C}$ to $+25^{\circ}\text{C}$.

No more than one (1) failure shall be permitted in twelve (12) units tested.

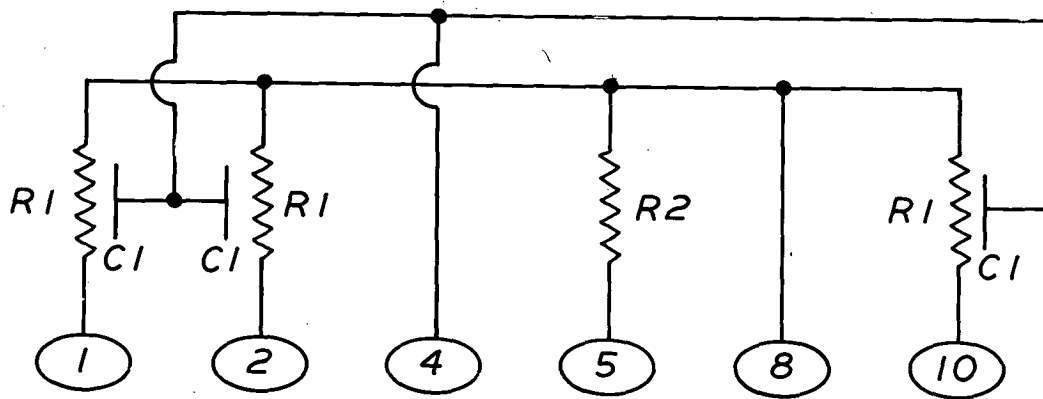

VALUES

$R1 = 1,290 \text{ OHMS}$

$R2 = 488 \text{ OHMS}$

$C1 = 30 \times 10^{-12} \text{ FARAD}$

COMPUTER SYSTEMS LABORATORY WASHINGTON UNIVERSITY ST. LOUIS, MISSOURI			MACROMODULAR PROJECT			
			TITLE SPRAGUE LTN-3 TERMINATING NETWORK (PARAMETER PLUG)			
			APPROVED		ENG	DRAWING NO.
G	1-6-72	E.C.O. 0243	BY	FOR	DATE	GCJ 010-22
ISSUE	1-8-71	gcj	gcj	MANUF	12-22-70	DRAWN BY PLL
CHANGE NO.	DATE	DESCRIPTION				CHECKED gcj DATE 10-13-70

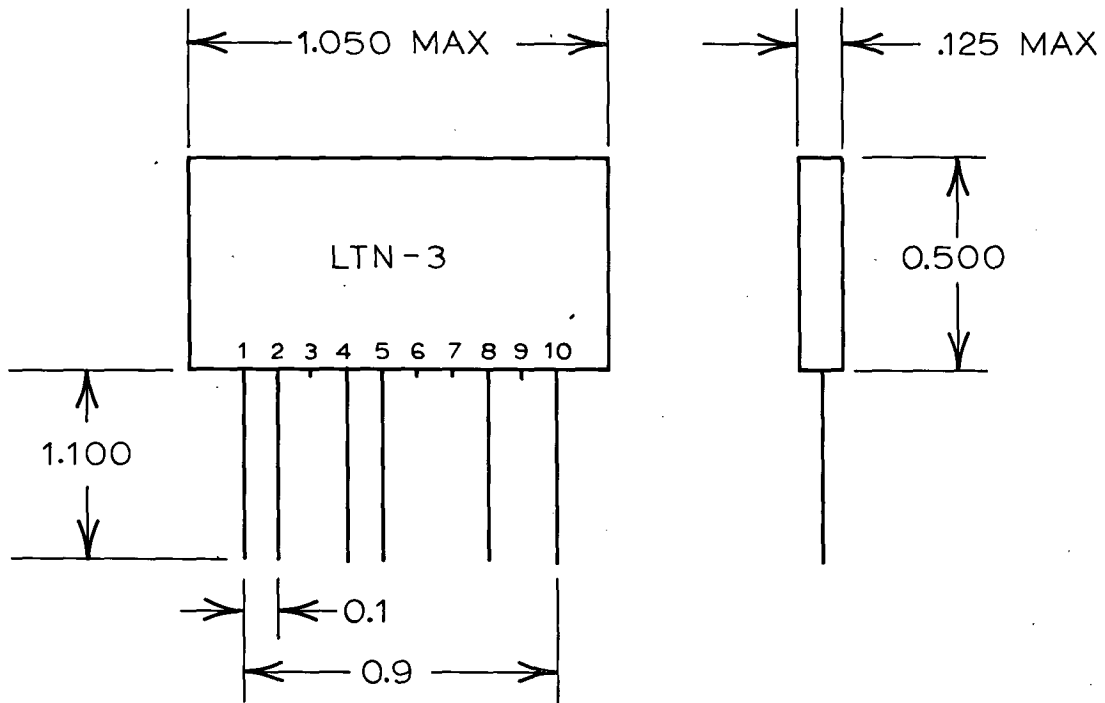

LEADS MISSING IN POSITIONS 3,6,7, & 9.

COMPUTER SYSTEMS LABORATORY WASHINGTON UNIVERSITY ST. LOUIS, MISSOURI			MACROMODULAR PROJECT				
			TITLE LTN-3 PACKAGE OUTLINE				
			APPROVED		ENG	DRAWING NO.	
G	1-6-72	E.C.O. 0243	GCJ	GCJ		010-23	
ISSUE	1-8-71	GCJ	GCJ	PROD	1-8-71		DRAWN BY PLL
CHANGE NO.	DATE	DESCRIPTION				CHECKED GCJ	DATE 10-13-70

General Printed Circuit Board Assembly Specification

General:

This specification covers the component assembly on three Macro-modular board types, the vertical board, the long and short mother boards. It does not cover the assembly of the Power Supply board which is covered separately by specification 010-35 thru 40. These boards are two sided 0.062" FR-4 laminate with plated through holes. For plating, hole dimensions and other details see Printed Circuit Specification PC-1. After cleaning, boards should be handled by the edges to avoid contamination of circuit surfaces with perspiration and skin oils. If surface contact is unavoidable, clean cotton gloves should be worn. Surfaces of areas used to handle or store circuit boards should be kept clean and free of material that might contaminate or damage board surfaces, and covered with carpeting or similar protective material. Circuit boards shall not be stacked on top of one another without the use of protective separators.

Components:

1. Integrated Circuits:

- a. Integrated circuits are 14 pin or 16 pin dual-in-line packages of the Motorola MC1000-P (plastic), MC1000-L (ceramic), or MC1200-L (ceramic) series that have been specially tested for use in these circuit boards. The dimensions and identifying marks are specified by the attached Motorola General Information Sheets for these series, pages 0.2-6. Parts are identified on assembly documents by a special number assigned by Washington University, consisting of the letter "M" followed

CHG.	E C C	DATE	APPR
-	0116	May 71	CLM
B	0178	5-11-71	CLM
E	0230	11-11-71	MTK

by two numerals and possibly a suffix letter (e.g. M01B). In general, the two digits in our designation match the last two digits of Motorola's part number. Material from the Motorola MC1000 series or MC1200 series in either the plastic or ceramic package may qualify according to our tests for interchangeable use in a particular circuit location. Parts are supplied by us with no additional identification other than the Motorola identification, except that parts bearing a suffix letter (e.g. M01B) bear an identifying colored dot.

The color code of the dot is as follows:

No color dot	No suffix
Red	A
White	B
Green	C
Blue	D
Yellow	E

Parts bearing different color dots should not be interchanged unless such interchange is specifically approved by Washington University. No integrated circuit material not supplied by us or tested to our specifications shall be used.

- b. Insertion of integrated circuits is accomplished by use of a special insertion tool, Dual In-Line Insert, #52, made by Techni-Tool. The use of this tool is facilitated by using a small metal block dimensioned to fit between the pins of the package. The block dimensions can be taken from Motorola descriptive literature for this type of integrated

circuit. The integrated circuits are to be inserted fully, so that the shoulders of all pins are in contact with the surface of the printed circuit conductor. In the insertion process, care must be taken that the portions of pins, close to the body of the package, are not compressed excessively in a manner that overstresses the bond of the pin to the body of the package. Pins number 7 and 14 (8 and 16 on 16 pin packages) may be bent over flush with their mounting pad to hold the package in place for soldering. These pins must be trimmed so that they do not extend beyond the edge of the conductor surface to which they are soldered.

2. Resistors

- a. Two types of resistors are used. Electra Type MF5C 1/8 watt 1% metal film resistors comprise approximately 90% of all axial lead components. They are fragile and subject to breakage by mechanical shock, compression, or lead stress. The second type used is Electra Type MF 07C 1/4 watt 5% carbon composition. They are supplied in reels and are color coded as follows.

1. Solid body color with colored stripe around middle. Stripe color conforms to standard electronic color code and is related to resistor part number in assembly documentation.

Resistor Identification Color Code

- | | |
|-------------------|----------------------|
| R0 - Black Stripe | - Zero Ohms (Jumper) |
| R1 - Brown Stripe | - 1.5 K Ohms |
| R2 - Red Stripe | - 750 Ohms |

Resistor Identification Color Code

R3 - Orange Stripe	- 121 Ohms
R4 - Yellow Stripe	- 15K Ohms
R5 - Green Stripe	- 57.6 Ohms
R6 - Blue Stripe	- 130 Ohms
R7 - Violet Stripe	- Unassigned
R8 - Gray Stripe	- Unassigned
R9 - No color	- Special

3. Jumpers:

- a. Jumpers are of two types. One type is identical with resistor body and is described above. Where other than standard component hole spacing is used and a jumper must be fabricated to fit, use #24 AWG tinned solid copper wire, encased in Teflon sleeving that provides a snug fit. The sleeving must cover the wire to within 1/16 inch of the point where the wire passes through the plated-through hole.

4. Diodes:

- a. Glass body diodes, 1N3604 are used.

5. Capacitors:

- a. Capacitors are Elemenco Dipped Silver Mica Capacitors - Type DM-15 500 WVDC 5% with radial leads.

Assembly:

1. Orientation:

Those components requiring orientation, diodes and integrated circuits, have the orientation specified on the assembly document.

Diode polarity is given by the color band designating the cathode end. Integrated circuits have a notch on the end of the package as described above.

2. Insertion:

Axial leads are, wherever possible, to be installed in plated-through holes 0.700 inch apart. Occasionally, mounting holes are a non-standard distance apart. Components for standard mounting holes may be pre-formed and pre-trimmed. Components for non-standard mounting holes need not be pre-formed and in addition the leads should be sleeved with close fitting Teflon sleeving. Leads may be bent, if necessary, for secure mounting during handling and soldering. Bent leads must be trimmed so that they do not extend beyond the edge of the conductor to which they are soldered.

3. Female connector sockets:

These are AMPMODU Model II type C female sockets with gold-plated finish, AMP number 85863-4, and are furnished as loose pieces.

They are used only on the vertical boards and must be oriented as shown on Enclosure A.

Connectors are mounted by inserting prongs through a pair of plated-through holes spaced 0.255 inch apart. Connector prongs are to be inserted fully so that the connector body is flush with and in contact with the conductor surface of the circuit board. Prongs are bent, as shown in Enclosure "A", so that they are flush with and in contact with the conductor surface of the printed circuit board. Care must be taken to ensure that bending the prongs does not lift the connector body from being flush

VERTICAL BOARD FEMALE INSTALLATION

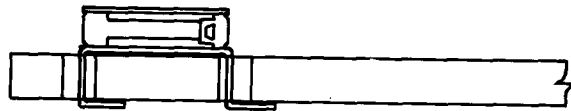

NOTE UNIDIRECTIONAL CRIMPING OF FEMALE

ENCL. "A"

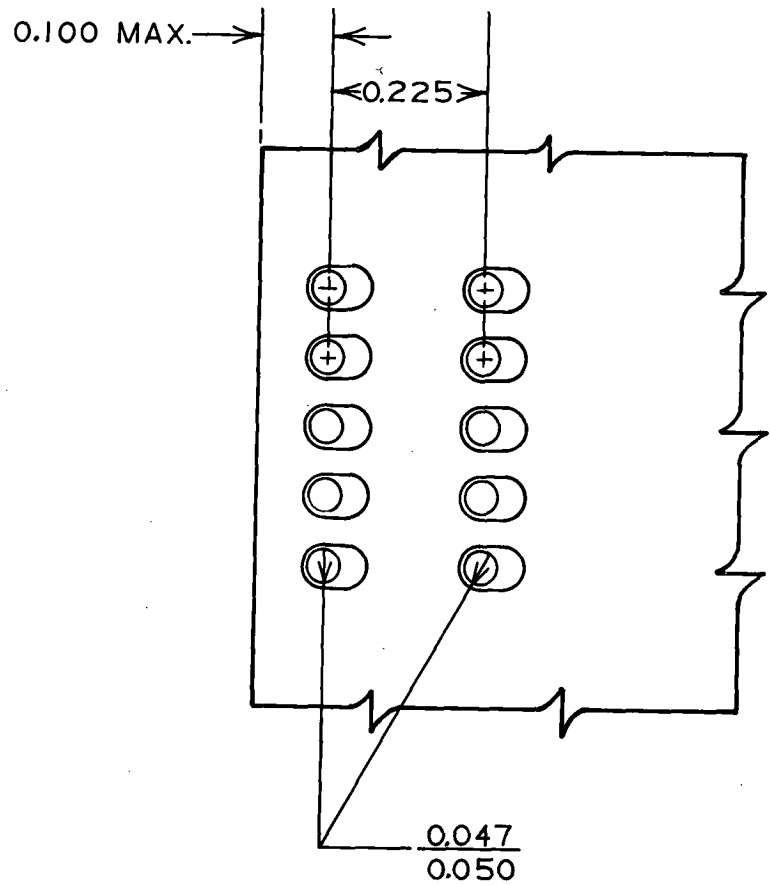

TYPICAL PAD LAYOUT FOR FEMALE

DRILL & TAP FOR 1-72 SCREW
C'SINK .125 D (3 HOLES)

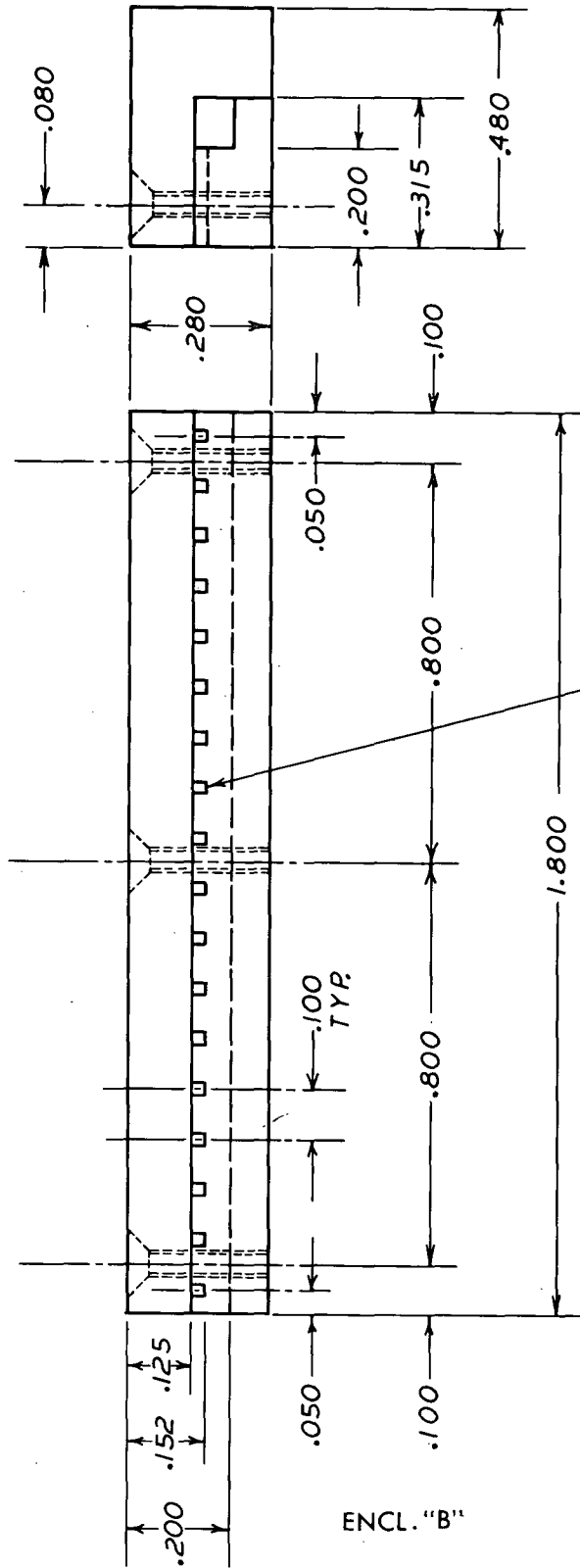
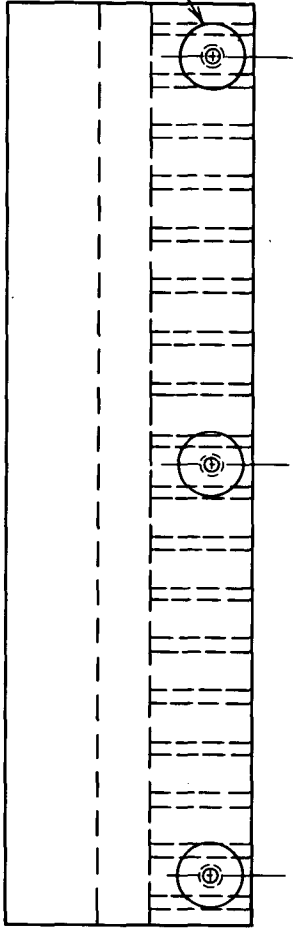

ENCL. "B"

18 NOTCHES .027 DEEP X .027 WIDE

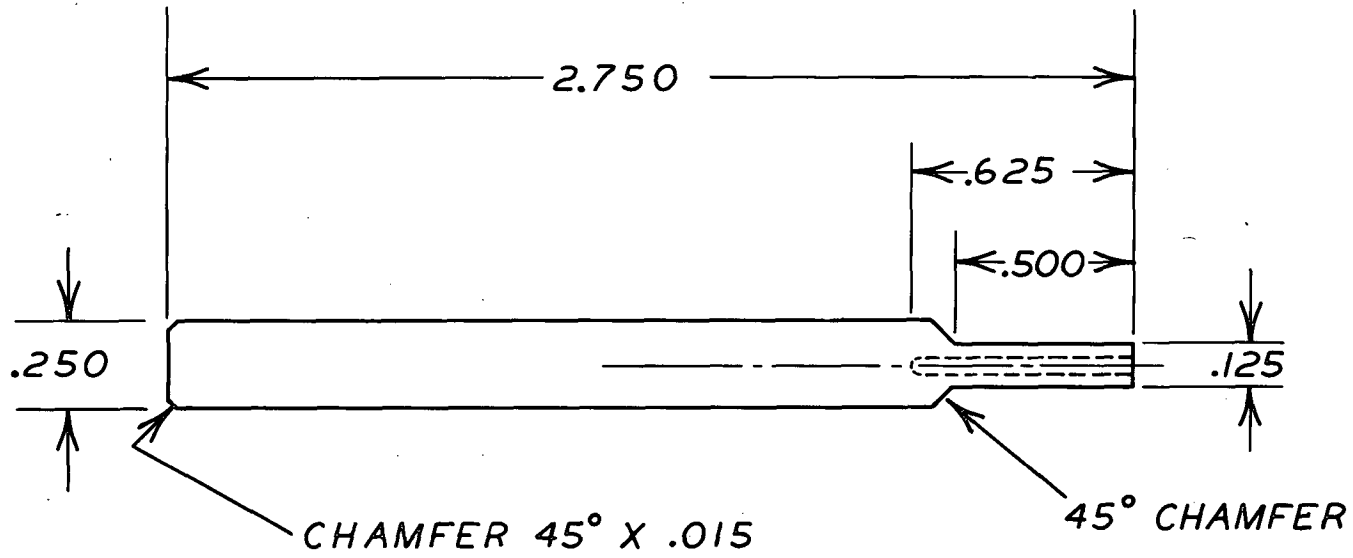

MATERIAL: .250 DELRIN
DIMENSIONS: $\pm .005$

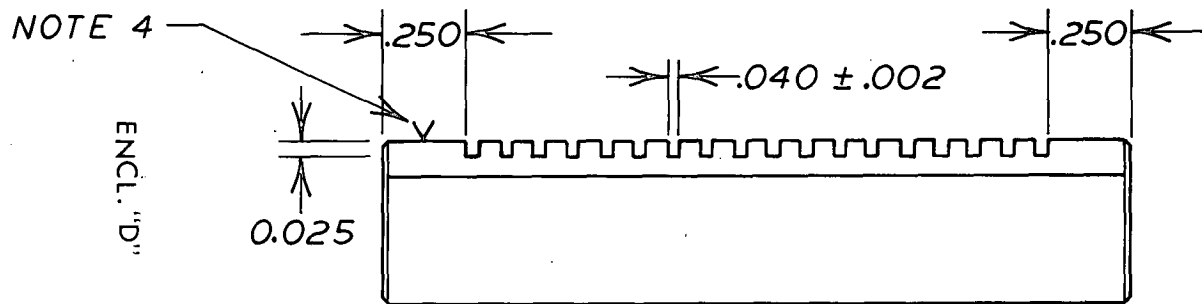
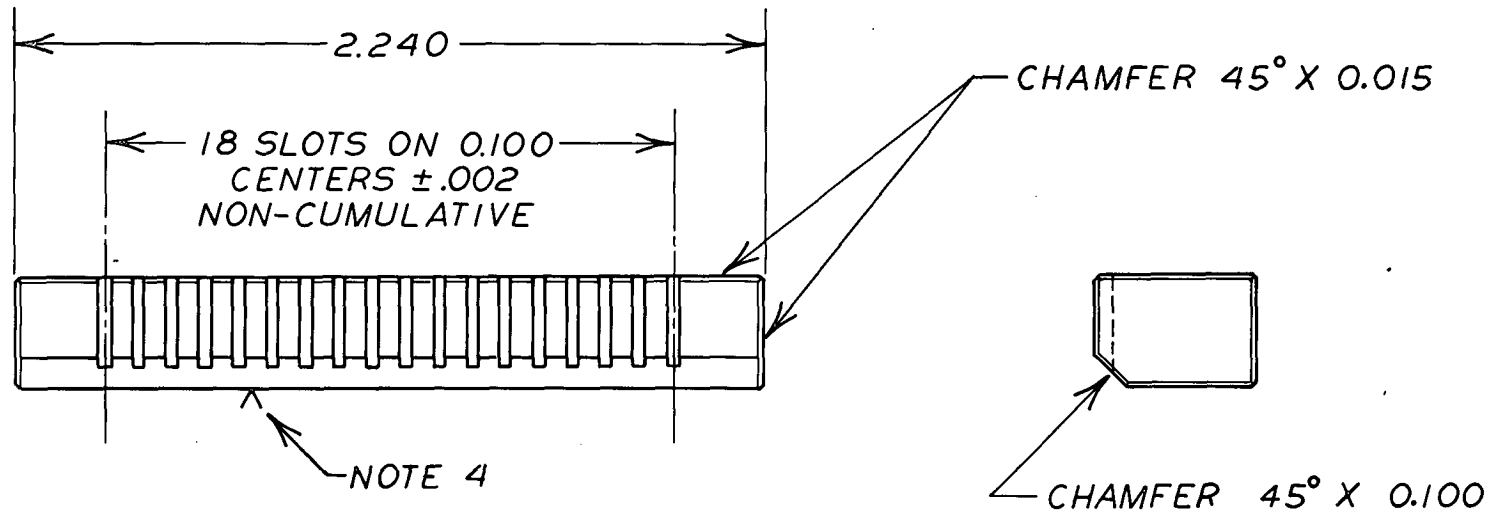

NOTES

1. DO NOT SCALE FROM PRINT.
2. MATERIAL IS T2024-T3 ALUM. °
3. TOLERANCES $\pm .005$ U.O.N.
4. MARKED SURFACES TO BE MILLED FLAT.
5. EDGES ARE TO BE FREE OF BURRS.

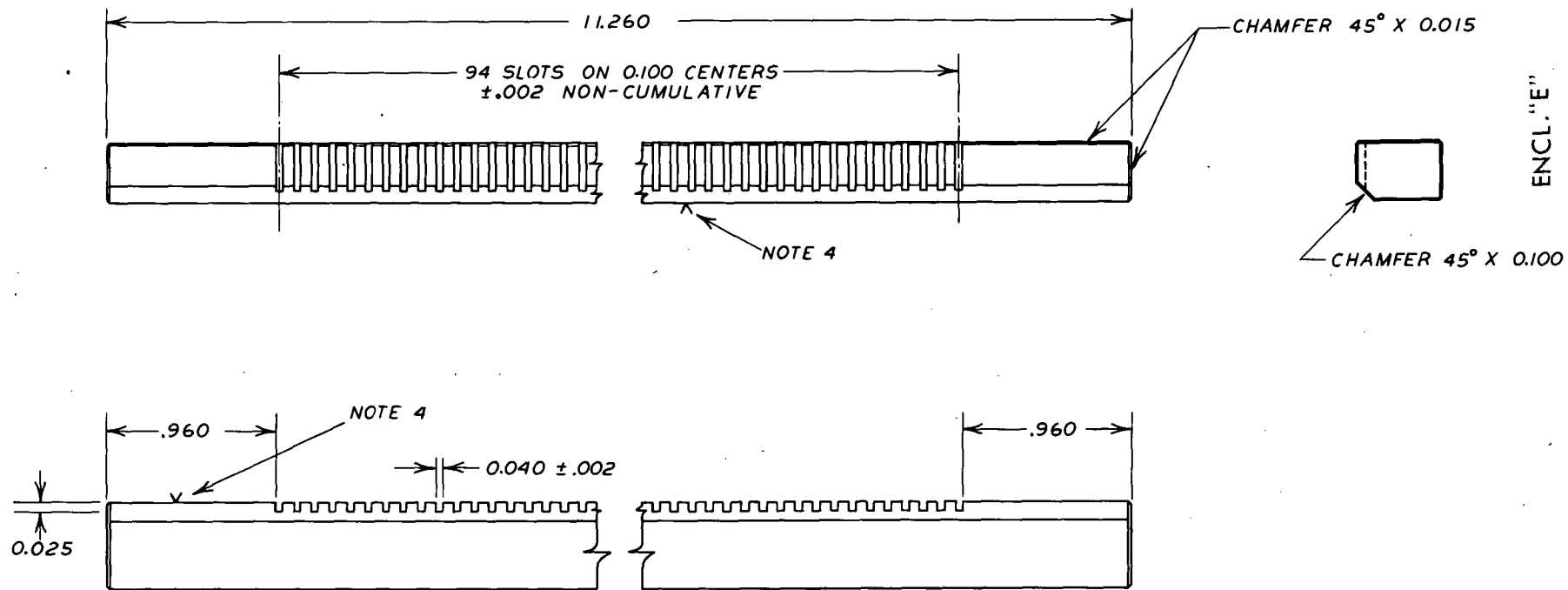

NOTES:

1. DO NOT SCALE FROM PRINT.
2. MATERIAL IS T2024-T3 ALUM
3. TOLERANCES ±.005 U.O.N.
4. MARKED SURFACES TO BE MILLED FLAT.
5. EDGES ARE TO BE FREE OF BURRS.

MOTHERBOARD MALE PIN ALIGNMENT

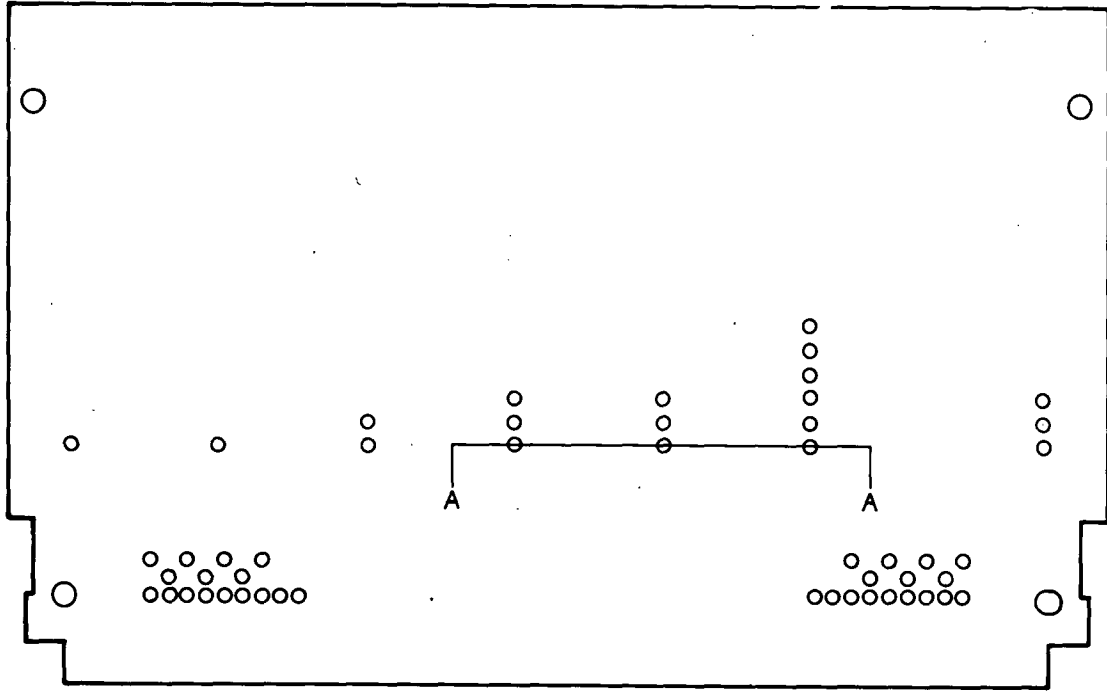

SECTION "A-A"

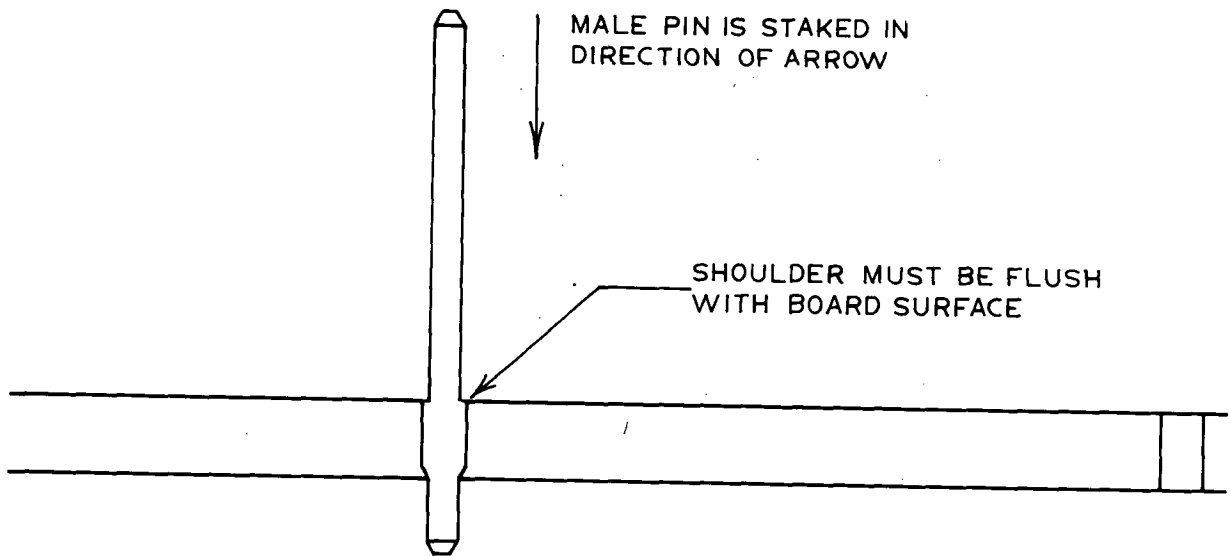

MALE PIN IS PRESS FIT IN 0.036 DIA. HOLE

ENCL. "F"

GENERAL ALIGNMENT—
MALE HAS TWO SMOOTH SURFACES AND MUST MATE
WITH FEMALE AS SHOWN

MALE 85931-5

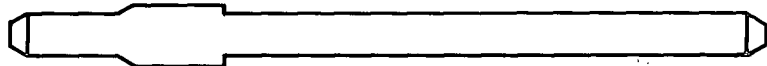
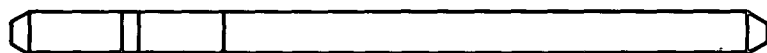

FEMALE 85863-4

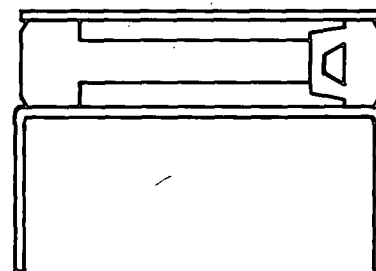

ENCL. "G"

with the printed circuit board surface. Any means of holding the connector sockets flush with the board, during this process, may be used that does not damage the connector.

4. Male connector pins:

These are AMPMODU MOD II gold-plated pins, Amp number 85931-5, supplied either on a reel or as loose parts. These pins are used only on the long and short mother boards and are staked in positions shown on individual assembly drawings. Pin shoulders are to be flush with the board surface to within ± 0.010 inches. See Enclosure "B" for sample staking tool used for this purpose with arbor press. Connector pins are to be inserted in the correct orientation as shown in Enclosure "F" & "G" to within ± 10 degrees rotation about the long axis. Pin alignment in the vertical shall be checked and corrected by means of alignment tools and pin straightener shown in Enclosures "C", "D", & "E". In no case should pins be straightened by use of metal tools, to avoid nicking the pin, and pins can only be bent a very few times before breaking.

5. Resistor Networks:

These are Sprague LTN-2, which are four 130 ohm resistors encapsulated in plastic to form one unit. They are sometimes shown with certain of the leads clipped. Care must be taken when inserting these units that the end of the clipped leads does not touch the circuit board. Scotch brand No. 33 tape shall be placed between the circuit board and the clipped portion of the LTN-2 with care being taken that the clipped ends do not penetrate the insulation material.

6. Mother Board Connectors, 90 Pin:

There are two types in use, the long mother board uses AMP 1-202-845-5 and the short mother board uses AMP 583 464-1.

The long mother board connectors come individually in plexi-glass tubes. The short mother Board connectors come two to a box. The connectors are fastened to the circuit boards by means of brass eyelets, E.B. Stimson A 1425. One of the two connector mounting holes in the circuit board is round and the other elongated to allow for connector tolerances. The eyelet must be fastened in the round hole first and must be pressed and not stamped in order to avoid breaking plastic ear of connector. See drawings 200.50D26, 200.50D27, 200.50D28 and 200.50D29 for proper orientation of connector on board, particularly note side of board that connector ear is in contact with.

On the short mother board the right angle connector pins pass through holes in the board. On the long mother board the board is placed between the rows of connector pins. In both cases during assembly and soldering, the connector should be mated with a female connector to protect pins from damage and to position pins properly within the connector block.

Soldering:

Soldering may be by flow techniques or hand techniques. Flow solder temperatures should be less than 600° F and hand solder tools must be equipped with a temperature controlled tip of 600° or less. Higher temperatures will raise the copper from the laminate. When soldering by flow techniques is used, the boards must be baked or preheated to remove residual moisture. If this is not done the heat of the solder bath will

cause the moisture to explode the copper from the laminate. Solder should form a clean, shiny surface with concave fillets. There should be good wetting of the surface of the pad and the component leads. Preferably the solder should penetrate through the plated-through holes and be visible from the component side but this is not a necessity. Proper solder temperature and eutectic control of solder has a direct bearing on this problem. In any case the solder-tin ratio should be properly maintained to do proper soldering.

Extreme care must be taken not to contaminate the female AMPMODU connectors with solder. Any solder on the connector which obstructs the opening for the male pin, contaminates the contact surfaces, or restricts the free motion of the contact springs is cause for rejection.

The male AMPMODU pins shall be free of solder to within 0.120 inch of the board surface. Solder is acceptable within this tolerance provided that it is a thin film rather than a blob or thick layer.

Cleaning:

After assembly and after any board repair the boards must be thoroughly cleaned of flux and other residues with DuPont TE35 Freon Flux Remover. Boards should then be scribed with a nylon bristle brush in a weak detergent solution in water to remove the residue from the flux remover. Boards should then be dried with a clean air blast to remove the water and any other foreign materials, slivers, clipped wire leads, etc. that might have lodged under the components.

Inspection:

1. Presoldering Inspection:

Before any assembly starts the printed circuit board should be examined to see that it is clean and free from oil, fingerprints,

dirt, moisture and other foreign material. The Institute of Printed Circuits, Inc. 1717 Howard Street, Evanston, Illinois 60202 puts out a book titled "Acceptability of Printed Circuit Boards" which shows what to look for in this inspection.

After assembly and before soldering, the boards should be inspected for proper component insertion and orientation. Correct component identification should be verified and all errors corrected before soldering.

2. Final Inspection:

Soldering:

All component leads requiring soldering are to be inspected for proper soldering and retouched as needed. As a general rule, solder touch up on the component side should be avoided. However when component side soldering is necessary, extreme care should be exercised to avoid creating solder bridges between closely mounted leads. Touch up of female AMPMODU connections generally leads to solder contamination of the connector. Touch up around the male AMPMODU pins tends to wick solder up the pin. Generally no solder should be found on any connector surface other than the portion in contact with the printed circuit board.

Care should be taken to differentiate between cold solder joints and dull discolored joints which resemble cold solder joints.

Nicks in copper paths greater than 30% of the conductor width are unacceptable.

Severe dewetting that leaves bare copper exposed is unacceptable.

Scratches or gouges causing functional board damage are unacceptable.

External stains, residue or contaminates between or adjacent to either conductors are unacceptable.

Circuit Board:

Any physical damage to the conductors or separation from the laminate base material is cause for rejection. Circuit board warpage that can be corrected by a five pound flattening weight is acceptable.

Trimming:

All component leads shall protrude less than 0.10 inch beyond the circuit board surface except 0.05 inches on short mother boards. All bent leads shall be trimmed so that they do not extend beyond the edge of the pad to which they are soldered.

Components:

Components should be examined for chipping and cracks. Resistors are susceptible to hair line cracks if lead bending is done improperly. Top of integrated circuits tend to separate from body if unit is improperly mounted so that a torque is present. Male AMPMODU pins bend very easily if board is mishandled. Female AMPMODU pins tend to stand up from board if not help properly when bending prongs. Check to see that no component lead is touching a copper path passing under it.

Shipping:

Printed circuit boards must be packed for shipment in such a manner that will effectively protect them from contamination and physical damage.

CHG.	E.C.O.	DATE	APPR.
E	0230	11-11-71	WTK.

Printed Circuit Board

Repair Criterion

- A. Defects on circuit boards found during inspection shall be corrected in a manner that will leave the resulting circuit board as similar as possible in appearance and reliability to a perfect board. Solder touch-up must be done with a temperature-controlled soldering iron such as the Weller WTCP, thermostatically controlled not to exceed a tip temperature of 600° F.
- B. Replacement of damaged or defective components shall be accomplished by first removing the excess solder by means of a vacuum device, then clipping off leads, and finally removing the leads one at a time. The printed circuit board shall be examined for evidence of separation of laminate after component removal and before insertion of a replacement component. The replacement component shall be of a type identical to that replaced unless specific approval is given for a substitution.
- C. Repair of defective or delaminated printed circuit conductors shall be made by soldering a piece of teflon sleeved tinned #30 solid wire so as to interconnect the two terminal points of the defective conductor. The defective conductor shall be removed from the circuit board. Conductor runs of greater than two inches will not be repaired in this manner.
- D. Boards shall be cleaned and inspected for residues following any rework.

Assembly Specification for Power Converter Boards

General:

Unless specifically modified herein, general assembly specification 010-24 thru 010-34 applies.

Assembly:

1. Axial-lead Components:

(a) Orientation

Those components requiring orientation (electrolytic capacitors and diodes) have orientation specified on the assembly document. Diode polarity is given by a white band, which designates the cathode end; or a diode symbol on the case of the diode. Capacitor polarity is printed as (+) or (-) on the capacitor body.

(b) Insertion

There is no standard distance between mounting holes. Components are formed to fit. Leads may be bent if required for secure mounting during handling and soldering. Bent leads must be trimmed so that they do not extend beyond the edge of the conductor to which they are soldered.

2. Power Transistors:

(a) Orientation

The power transistors will fit the mounting holes in only one orientation. In no instance is the orientation to be based upon the transistor identification number or date code orientation.

CHG.	E.C.O	DATE	APPR
-	ORIG	7 May 71	CEM
B	0178	5-11-71	CEM

(b) Insertion

The transistors are to be inserted fully, so that all the dimples on the bottom of the transistor are in contact with the surface of the printed circuit board. The leads may be bent if required for secure mounting during handling and soldering. Bent leads must be trimmed so that they do not extend beyond the edge of the conductor to which they are soldered.

3. Inductors:

(a) Orientation

L1 may be mounted in two orientations, either is acceptable. L2 must be mounted to provide maximum spacing between L2 and C2. In no instance is the orientation of either inductor to be based on the identification number orientation.

(b) Insertion

The inductors are mounted with RTV silicone rubber between the inductor and the printed circuit board. The inductor feet shall be within 0.020 inches of the printed circuit board and the RTV shall fill at least 3/4 of the area under the inductor. No RTV shall extend more than 0.050 inches beyond the edge of the inductor. The leads may be bent if required for secure mounting during handling and soldering. Bent leads must be trimmed so that they do not extend beyond the edge of the conductor to which they are soldered.

4. Transformers:

(a) Orientation

T1 can be mounted in only one orientation. T2 must be mounted with the wires extending from the transformer oriented as shown on assembly document. In no instance is the orientation to be based upon the transformer identification number orientation.

(b) Insertion

T1 must be inserted fully, so that the feet on the bottom of the transformer are in contact with the surface of the printed circuit board.

T2 is mounted with RTV silicone rubber between the transformer and the printed circuit board. The transformer is to be inserted fully, so that the shoulders of all pins are in contact with the surface of the printed circuit board. The RTV shall fill at least 3/4 of the area under the transformer. No RTV shall extend more than 0.050 inches beyond the edge of the transformer. The two leads extending from the transformer that are twisted together are inserted into the two holes marked "8" on the printed circuit board. The other two wires are inserted into the holes marked "7" and "9" in any order.

Leads may be bent if required for secure mounting during handling and soldering. Bent leads must be trimmed so that they do not extend beyond the edge of the conductor to which they are soldered.

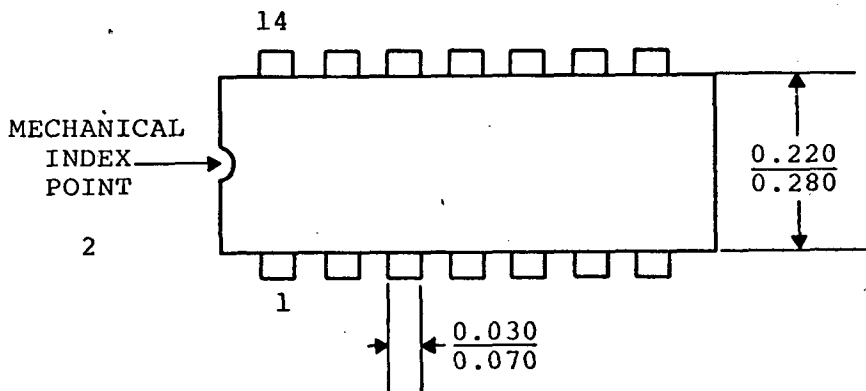

L SUFFIX
CERAMIC PACKAGE
CASE 605C
TO-116

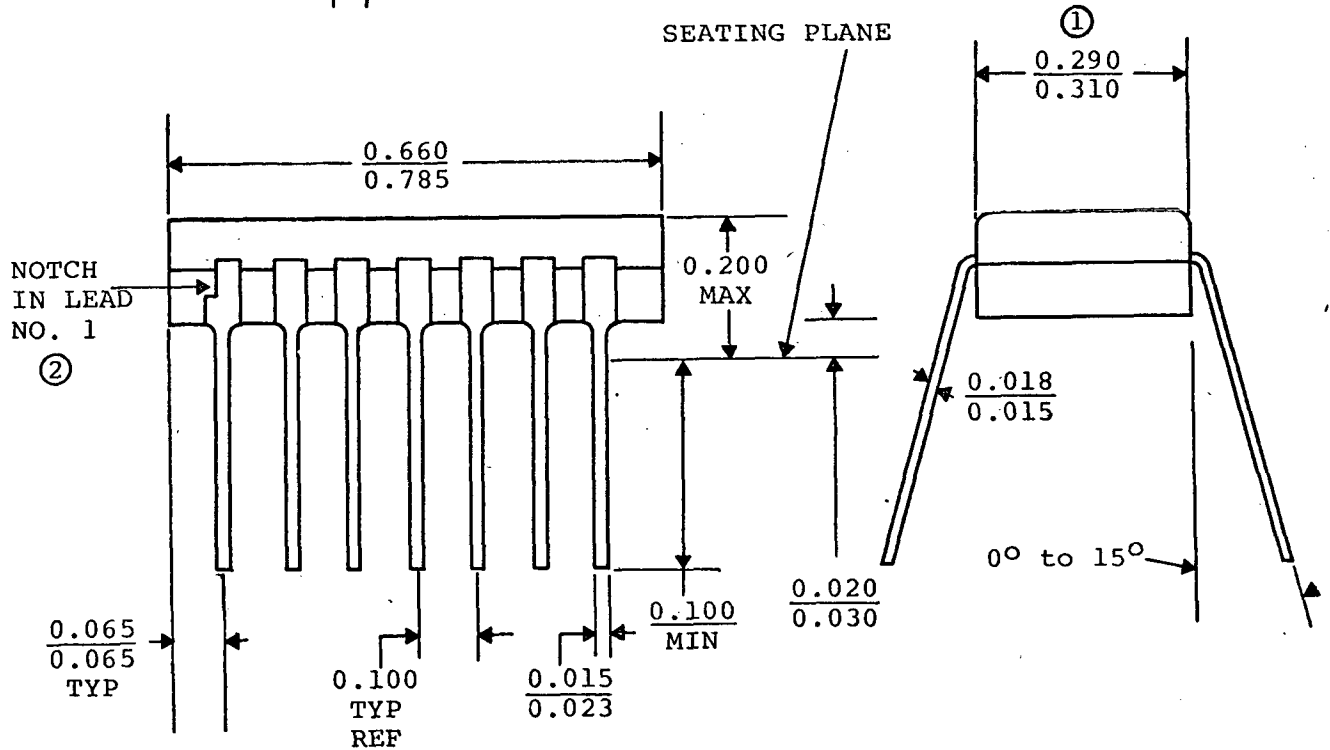

- ① This dimension is measured from the lead centers at the seating plane.
- ② Orientation will be indicated either by mechanical index point or notch in pin 1 as shown.

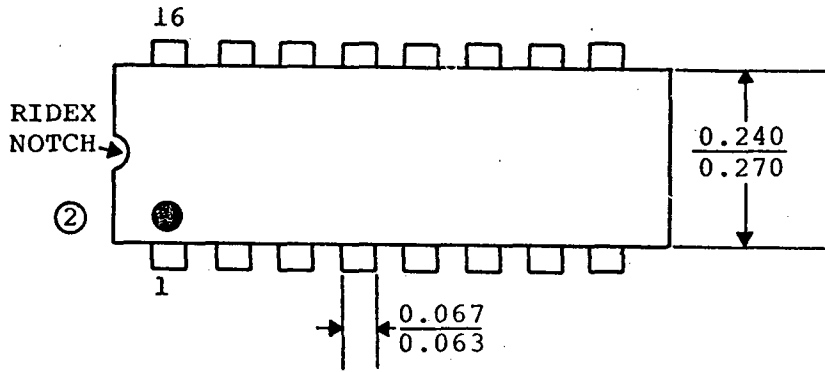

L SUFFIX
 CERAMIC PACKAGE
 CASE 620

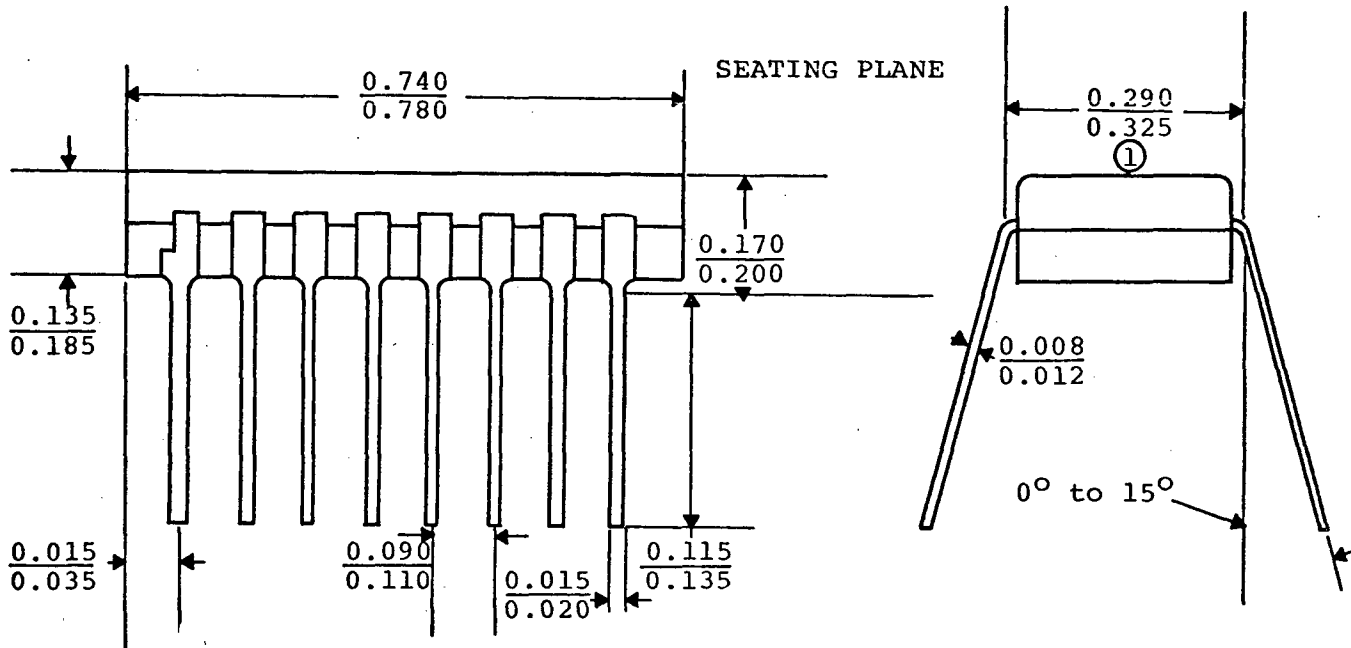

- ① This dimension is measured from the lead centers at the seating plane with leads vertical.
- ② Lead 1 identified by color dot, notch in lead, or notch in ceramic.

FREON® T-E 35

PRODUCT DESCRIPTION

"Freon" T-E 35 is a blend of "Freon" TF with 35% specially denatured ethyl alcohol. It is designed to combine the properties of ethyl alcohol with those of "Freon" TF for cold cleaning process.

WHERE USED

"Freon T-E 35 provides good solvency for both organic and polar soils. It is one of the most gentle and effective rosin flux removers and is used to clean:

- Printed Circuit Boards
- Electrical Relays
- Precision Capacitors
- Potentiometers.
- Hearing Aids
- Electrical Meters & Timers
- Missile Guidance Systems

COMPATIBILITY

"Freon" T-E 35 is useful for cleaning components whose materials of construction are quite sensitive to strong organic solvents.

CLEANING PROCESSES

"Freon" T-E 35 is designed to be used only in cold cleaning processes. They include dipping with or without ultrasonics, and flushing. It readily fits into multi-stage operations where it is usually followed by a rinse in "Freon" TF. Since "Freon" T-E is a blend of "Freon" TF and ethyl alcohol, the composition of liquid and vapor will change during evaporation. As it evaporates, the residual solvent will become flammable due to alcohol enrichment.

PACKAGING AND AVAILABILITY

"Freon" cleaning agents are available in 5, 20 and 55 gallon drums, in tank truck and tank car quantities. They can be ordered by contacting these offices:

E. I. du Pont de Nemours & Co. (Inc.)
"Freon" Products Division
Wilmington, Delaware 19898
Phone: (302) 774-8341

From New York City Area:
(212) 265-1391

From Northern New Jersey Area:
(201) 622-3680

E. I. du Pont de Nemours & Co. (Inc.)
"Freon" Products Division
701 Welch Road
Palo Alto, California 94304
Phone: (415) 326-2840

From Southern California:
(213) 443-0191

From all other locations East of the Rocky Mountains: (800) 441-9450

FREON is Du Pont's registered trademark for its fluorocarbon compounds.

The information contained herein is based on technical data and tests which we believe to be reliable and is intended for use by persons having technical skill, at their own discretion and risk. Since conditions of use are outside of Du Pont's control, we can assume no liability for results obtained or damages incurred through the application of the data presented, nor can we assure customers of freedom from patent infringement in the use of any formula or process described herein.

E. I. DU PONT DE NEMOURS & CO. (INC.) • "FREON" PRODUCTS DIVISION • WILMINGTON, DELAWARE 19898



Better things for better living ... through chemistry

Boiling Point at One Atmosphere, °F	119 ^a
Freezing Point, °F	-108
Liquid Density at 77°F, lbs/gal	9.75
grams/cc	1.168
Surface Tension at 75°F, dynes/cm	19.6
Solubility of Water at 75°, wt %	6.3
Latent Heat of Vaporization at the Boiling Point, Btu/lb	149.
Flash Point	None to boil ^b
Color	Clear, colorless
Toxicity (TLV) ppm by volume	ca. 1000*

a. Initial boiling point

b. None to about 25 volume % evaporation

*Calculated from recommended Threshold Limit Values for the individual components.

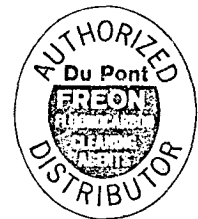

"Freon" cleaning agents are also available from authorized distributors throughout the United States who are identified by this symbol.



COMPUTER SYSTEMS LABORATORY
724 SOUTH EUCLID AVENUE

TELEPHONE: AREA CODE 314
FO 1 - 7356

July 28, 1971

MACROMODULAR DATA CABLE MODEL D SPECIFICATION CAS-6

PREPARED BY: *Gerald C. Johns* 8-5-71

INTRODUCTION:

This specification gives complete electrical and mechanical details for a part which is known as the Macromodular Data Cable Model D. This cable will be used to transmit high speed digital information between modular computer assemblies. The twisted pairs used in this cable will also be packaged separately for a wire harness assembly.

GENERAL:

The wire and cable described here shall conform to the quality and workmanship standards outlined in Brand Rex Commercial Specification BR-212C, November 1966. The Model D cable has insulation materials, color codes, and certain mechanical characteristics which are similar to Brand Rex Type BDW Twisted Pair Buried Distribution Wire (Catalog W668).

INDIVIDUAL CONDUCTORS:

WIRE:

The individual conductors shall be #30 AWG oxygen free copper with a silver coating.

CONDUCTOR: #30 solid OFHC copper

NOMINAL DIAMETER: 0.0100 inches

MINIMUM DIAMETER: 0.0099 inches

MAXIMUM DIAMETER: 0.0103 inches

COATING: Silver (not less than 40 microinches thick)

CHG.	E.C.O.	DATE	APPR.
C	0222	7-28-71	<i>gcj</i>

INSULATION:

The wires shall be covered with extruded high density, heat stabilized polyethylene.

MATERIAL: extruded polyethylene

WALL THICKNESS NOMINAL: 0.007 inches

WALL THICKNESS MINIMUM: 0.006 inches

WALL THICKNESS MAXIMUM: 0.008 inches

COLORS: white, red, yellow, violet, blue, orange, green, brown, and slate

MATERIAL DIELECTRIC CONSTANT: 2.34 nominal

POWER FACTOR: less than 0.0005 at one megahertz

TWINNING:

There shall be seventeen twisted pairs with colors and pitch as shown in the following table.

PAIR NUMBER	TIP	RING	PITCH (INCHES PER TWIST)
1	Violet	Blue	1/2
2	Violet	Orange	3/4
3	White	Green	1
4	Red	Brown	1 1/4
5	Yellow	Slate	1 1/2
6	White	Blue	3/4
7	Red	Orange	1
8	Yellow	Green	1 1/4
9	White	Brown	1 1/2
10	Red	Slate	3/4
11	Yellow	Blue	1
12	White	Orange	1 1/4
13	Red	Green	1 1/2
14	Yellow	Brown	3/4
15	White	Slate	1
16	Red	Blue	1 1/4
17	Yellow	Orange	1 1/2

CABLE DESCRIPTION:

The seventeen twisted pairs shall be bunched in a unidirectional lay with the core of the bundle made up of pairs 1 through 5 inclusive. The spatial arrangement of the pairs shall be as close as possible to Drawing 010-46. The bundle of seventeen pairs shall be wrapped with an 0.001 inch Mylar tape with a 10% overlap.

INNER JACKET:

The wrapped bundle shall be covered by an extruded black high density polyethylene jacket.

MATERIAL: high density polyethylene

WALL THICKNESS NOMINAL: 0.007 inches

WALL THICKNESS MINIMUM: 0.005 inches

WALL THICKNESS MAXIMUM: 0.009 inches

DIELECTRIC CONSTANT: 2.34 nominal

SHIELD:

The jacketed pairs shall be covered by a braided copper shield with a high braid angle.

WIRE: #34 AWG tinned copper

BRAID ANGLE: 50 degrees nominal

WALL THICKNESS: 0.028 inches nominal

OUTER JACKET:

The cable shall be finished with an extruded soft PVC jacket.

MATERIAL: PVC (similar to Geon 8806 black)

WALL THICKNESS NOMINAL: 0.030 inches

WALL THICKNESS MINIMUM: 0.025 inches

WALL THICKNESS MAXIMUM: 0.035 inches

COLOR: chrome grey

MANUFACTURING:

The outside surface of the cable shall be smooth and bear no brand or model markings. The maximum outside diameter of the completed cable shall be 0.312 inches. The minimum acceptable length for shipping is 100 feet. A sketch of the completed cable is shown on Drawing 010-45.

The completed cable shall be put up on large diameter spools with a low winding tension to insure maintenance of a round shape.

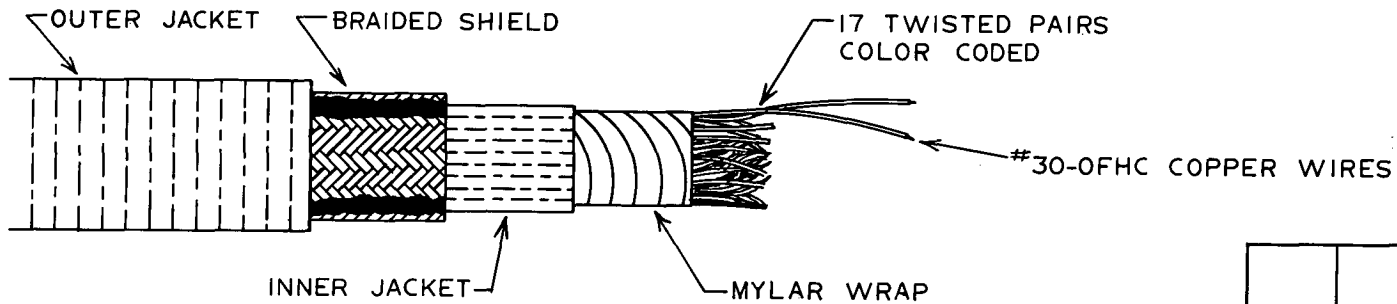

	C	7-29-71	E.C.O. 0222 <i>gcj</i>
CHANGE NO.	DATE	DESCRIPTION	
COMPUTER SYSTEMS LABORATORY WASHINGTON UNIVERSITY ST. LOUIS, MISSOURI			
MACROMODULAR PROJECT			
TITLE			
MACROMODULAR DATA CABLE MODEL C			
APPROVED			ENC.
BY	FOR	DATE	G C J
<i>gcj</i>	PROD	7-29-71	DRAWN BY
			P L L
			CHECKED
			G C J
			DATE
			7-29-71
			DRAWING NO.
			010-45

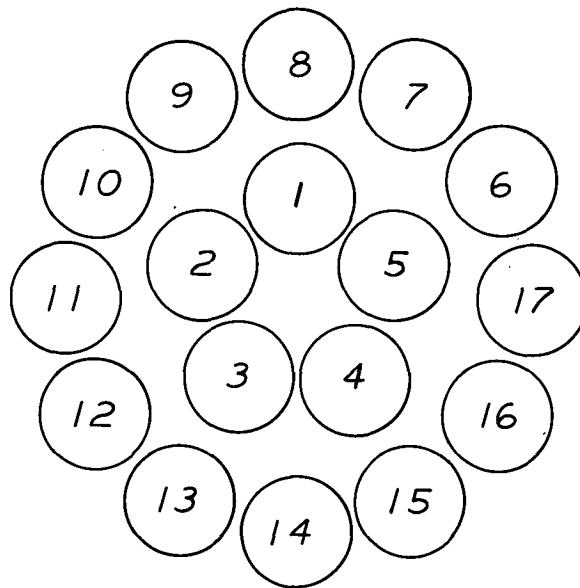

C	7-29-71	E.C.O. 0222	<i>gcj</i>
CHANGE NO.	DATE	DESCRIPTION	
COMPUTER SYSTEMS LABORATORY WASHINGTON UNIVERSITY ST. LOUIS, MISSOURI			
MACROMODULAR PROJECT			
TITLE DATA CABLE PAIR ORIENTATION			
APPROVED		ENG.	DRAWING NO.
BY	FOR	DATE	
<i>gcj</i>	PROD.	7-29-71	010-46
		DRAWN BY	
		PLL	
		CHECKED	DATE
		GCJ	7-29-71

MACROMODULAR CONTROL CABLE SPECIFICATION CAS-7

Introduction:

This specification gives an electrical and mechanical description of the Macromodular Control Cable. This cable will be used to transmit high speed digital control information between modular computer assemblies.

General Specifications:

The cable described here shall conform to quality and workmanship standards such as those outlined in Brand Rex Commercial Specification BR-212C, November 1966.

Mechanical Description:

The cable is a two conductor, twisted pair, shielded cable similar to CAS-4 with a stronger shield.

2 Components - F03013 SPCWLD - Solid Colors
(Conductor #30 Solid - Annealed - Silver Plated
Copperweld - .010" O.D.)
(Insulation - .013" Nom. Wall FEP - Colors
Natural and Yellow)

2 Components Twisted @ 1.0" L.H. Lay - .072" O.D.
Shield Jacket - #34 T/C - 90% Coverage
Jacket PVC -.035" Nom. Wall - Color Black - .160" \pm .010 O.D.

CHG.	F.C.O.	DATE	APPR.
H	0246	1-11-72	DCJ

Electricals:

DC-R 0.263 OHMS/FT @ 68° F

Mutual Capacitance - 25 MMF/FT

Impedance 120 OHMS \pm 10%

Conductivity - 40%

55,000PSI Min.

8% Elongation - Min.

Random Lengths - 100 Ft. Min.

The outside diameter is constrained by the connector to be 0.160 \pm 0.010 inches. The outside jacket is to be black, pressure molded PVC with no brand markings.

Electrical Description:

The major electrical requirement is that the balanced impedance between the inner conductors shall be 120 ohms. The characteristic impedance will meet the following limits:

Maximum Z_0 132 ohm

Nominal Z_0 120 ohm

Minimum Z_0 110 ohm

The manufacturer shall adjust the internal dimensions to achieve the specified impedance.

CHG.	E.C.O.	DATE	APPR.
H	0246	1-11-72	<i>dcj</i>

INTERLOCK NETWORK

This resistor network is used in the interlock module to provide the offset voltages necessary to detect the metastable condition of the arbitrating latch.

CHG.	E.C.D.	DATE	APPR.
L	0287	3-3-73	<i>scj</i>

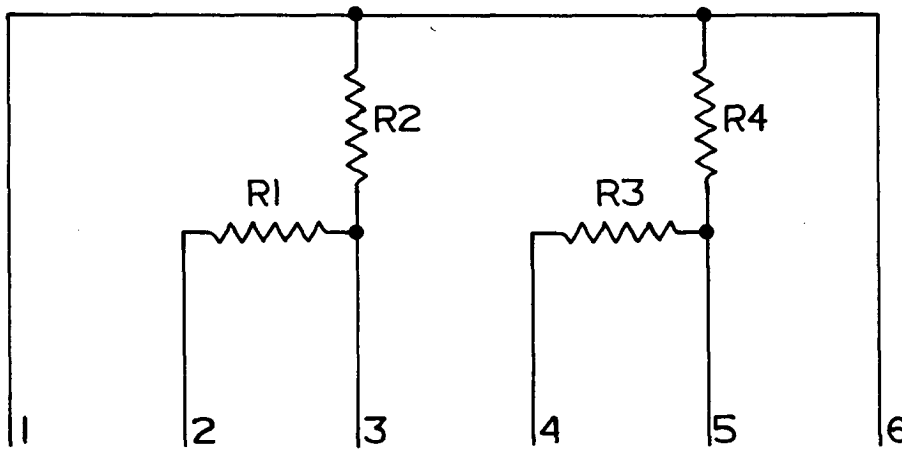

R1, R3 253 OHMS $\pm 0.5\%$, T.C. ± 100 ppm/ $^{\circ}$ C
 R2, R4 1745 OHMS $\pm 0.5\%$, T.C. ± 100 ppm/ $^{\circ}$ C

CTS SERIES 750 PACKAGE*, 6 PIN, 0.1" LEAD CENTERS, PACKAGE:

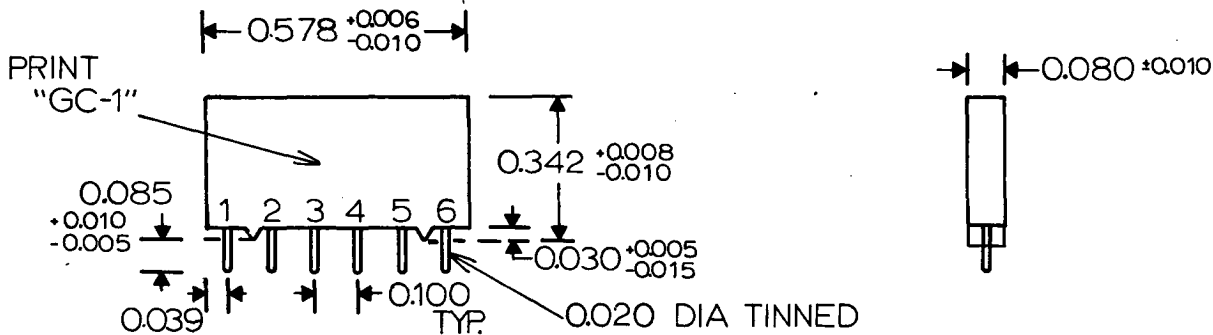

*750 SERIES PACKAGE DEFINED BY CTS DATA SHEET NUMBERED 3750D (SEE CSL 010-51 AND 010-52).

COMPUTER SYSTEMS LABORATORY WASHINGTON UNIVERSITY ST. LOUIS, MISSOURI			MACROMODULAR PROJECT			
L	3-2-73	E.C.O. 0287 <i>ecj</i>	APPROVED BY <i>T.J.C.</i> FOR _____ DATE <i>3-2-73</i>		ENG TJC	DRAWING NO. 010-50
A	2-15-73	MOVED R4 FROM PIN 4 TO PIN 5	CHECKED <i>T.J.C.</i>		DRAWN BY MAC	
CHANGE NO.	DATE	DESCRIPTION			CHECKED <i>T.J.C.</i>	DATE 11-10-72

CTS series 750 cermet resistor networks

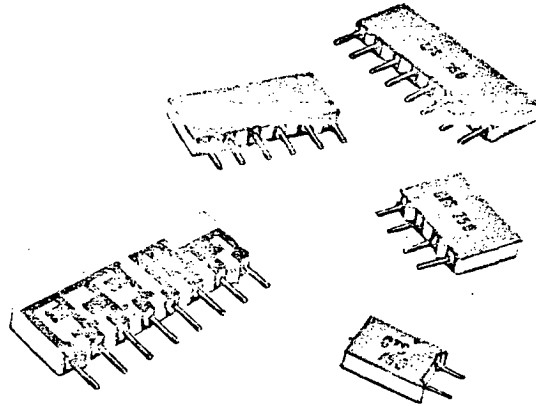

electrical and mechanical specifications

Resistance Range:

- Standard - 50 ohms through 100K ohms
- Special - 10 ohms to 50 ohms and above 100K ohms through 1 megohm

Temperature Coefficient:

- Standard - +250 ppm/°C
- Special - to +100 ppm/°C

Resistor Material:

Cermet - thick film

Resistance Tolerance:

- Standard - +5%
- Special - to +0.5%

Lead Strength:

5# pull

Power Rating, Watts:

Module @ 70°C

Lead Centers	Number of Pins										
	2	4	5	6	7	8	9	10	11	12	13
.100"	-	.7	-	1.0	-	1.3	-	2.0	2.3	-	-
.125"	.5	1.0	-	1.5	-	2.0	-	-	-	-	-
.150"	-	1.3	1.7	2.0	2.3	2.6	3.0	3.3	3.6	4.0	4.3

DATA SHEET 3750D

CHG.	E.C.O.	DATE	APPR.
L	0287	3-3-73	DCJ

ENVIRONMENTAL PERFORMANCE CHARACTERISTICS

TEST	Allowable Resistance Change	
	CTS Max. ΔR	CTS Avg. ΔR
SHORT TIME OVERLOAD: 2.5 times rated voltage, 5 sec.	+0.25%	+0.05%
LOW TEMPERATURE EXPOSURE: -63°C, 4 hrs.	+0.10%	+0.04%
TERMINAL STRENGTH: 5 lb. tensile & compression, 30 sec.	+0.10%	+0.03%
EFFECT OF SOLDERING: 63/37 solder, 246°C, 2 sec.	+0.10%	+0.05%
LOAD LIFE: 0.1 watt per resistor at 70°C, 1000 hrs.	+0.40%	+0.20%
MOISTURE RESISTANCE: .1 rated wattage at 70°C, 90-98% humidity, 1000 hrs.	+0.50%	+0.20%
INSULATION RESISTANCE: Measured wet after moisture resistance test, 200 VDC	500 megohm	
THERMAL SHOCK: 5 cycles, -63°C to +125°C, no load	+0.10%	+0.03%

CTS SERIES 750

NO. OF PINS	A DIMENSION
2	.228
4	.478
6	.728
8	.978

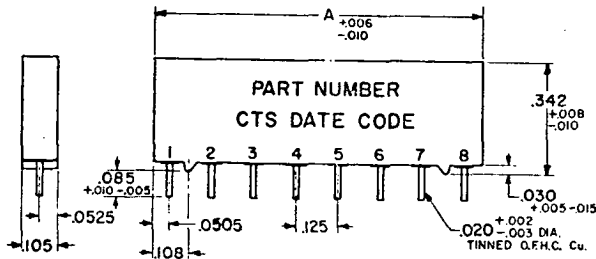

.125" centers

NO. OF PINS	A DIMENSION
4	.588
5	.738
6	.888
7	1.038
8	1.188
9	1.338
10	1.488
11	1.638
12	1.788
13	1.938

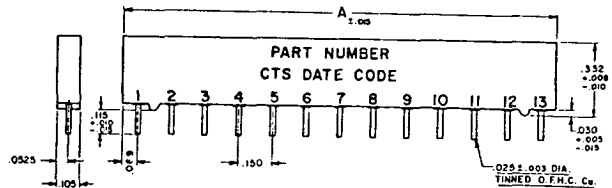

.150" centers

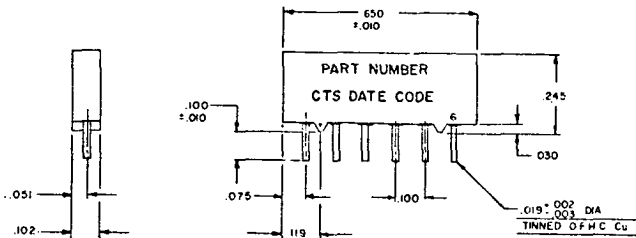

.100" centers (low profile)

NO. OF PINS	A DIMENSION	B DIMENSION	C DIMENSION
4	.578	.342	.080
6	.578	.342	.080
8	.778	.342	.080
10	.978	.342	.080
11	1.078	.332	.088

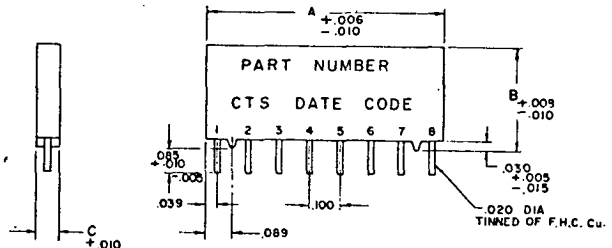

.100" centers

order from:

CTS OF BERNE, INC./405 Parr Road/Berne, Indiana 46711/(219) 589-3111
(Subsidiary of CTS Corporation, Elkhart, Indiana 46514)

CHG.	E.C.O.	DATE	APPR.
L	0287	3-3-73	<i>pcj</i>

Multi-Layer P.C. Board Specification PC-2

I. Scope:

This document provides general specifications for multi-layer printed circuit boards with solder plated plated-through holes for use in macromodule subassemblies. These general specifications apply to all multi-layer circuit board types unless specific exception is made within the documents describing a particular circuit board type.

II. Material:

Material is to be type FR-4. Thickness of finished boards is to be as shown in Figures 1 and 2.

III. Plating:

Finished thickness of copper on conductors, pads and terminal areas shall be from 0.002 to 0.003 inches. Thickness in holes is given below. A layer of lead-tin alloy shall be plated to a depth of 0.0003 to 0.0007 over all copper surfaces. All circuit boards shall have the solder plating on both surfaces reflowed by means of a hot peanut oil, hydro-squeegee, or similar process in order to melt back plating overhang. Final plated surface shall be free of contamination and shall be free from defects that may be detrimental to good soldering.

When areas of gold plating are specified (such as contact fingers) there shall be a minimum of 0.000050 inches of gold over a minimum of 0.000150 inches of nickel. The gold shall be free of porosity or nodules.

IV. Etching:

Areas not intended to have conductor shall be etched free of any copper residue. Undercutting should not exceed copper thickness. Undercutting should not produce splinters along conductor edges.

CHG.	E.C.O.	DATE	APPR.
N	0296	9-7-73	J. KR

V. Dimensional tolerances on final etch pattern:

A. Conductor paths corresponding to 0.040 tape in the 4:1 artwork shall have a minimum width of 0.008 inch and a maximum width of 0.012 inch. Width as narrow as 0.005 inch is acceptable for a distance not exceeding 0.020 inch along a line, but not in the area where a line joins a pad. No more than five such narrowings are allowable on one surface of any circuit board.

B. Width greater than 0.012 inch shall be acceptable if minimum clearances are maintained between conducting paths and providing that no more than 10% of the length of a given line exceeds a width of 0.012 inch.

C. A minimum clearance of 0.007 inch between adjacent conducting areas shall be maintained.

VI. Plated-through holes:

A. One plated-through hole type is generally used. Additional plated-through and non-plated-through hole types may be specified for individual board designs.

1. Type "1" holes are plated through with a finished diameter after copper and solder plating of .033 to .038.

B. Holes should be plated through unless otherwise specified. Finished Plating thickness of copper on the wall of the hole shall be a minimum average of 0.001 inch as measured at three points at least 0.010 inches apart. No single measurements shall be less than 70% of this minimum. Pinholes, voids, pits and projections are excluded from these measurements.

C. No more than three voids per hole are permitted. Total area of the voids shall not exceed 10% of the total wall area. Largest dimension not to exceed 25% of the core circumference or 25% of the thickness of the board.

D. No plated hole shall have voids or pits at the junction of the hole wall and terminal area to a depth of 1-1/2 times the total copper thickness on the surface.

E. A minimum annular ring of .005 inches must be maintained around each hole for external layers.

F. Hole diameter tolerances given apply prior to the reflow operation. Reduction of hole diameter of 15 percent or less during reflow is acceptable.

VII. Unplated holes:

Registration and reference holes are not plated through, and generally are 0.093 + or - 0.003 inches unless otherwise shown on individual board documents. Additional types may be specified for individual board designs.

VIII. Hole positioning:

A. All holes are to be registered to within \pm 0.005 inches of true position with respect to other holes.

IX. Artwork:

A. Artwork for circuit boards is prepared as follows: Master Pad Patterns are taped at 4:1 on 7 mil mylar on an etched glass grid plate with 0.050 spacing between grid lines. Cronaflex prints made from the Master Pad Pattern are used for taping the artwork for both sides of the circuit board to ensure registration.

B. Minimum clearance of 0.045 is maintained between taped regions that are not in contact. This minimum clearance generally occurs only at the nearest approach of a printed circuit line to a pad.

C. Minimum pad size of 0.250 inch O.D.

D. Pads used for clearance on inner layer will be enlarged to .340 inch O.D.

E. No conducting paths are taped with tape less than 0.040 inches wide.

F. Artwork is generally supplied in the form of 4:1 Cronaflex contact prints of the taped artwork. The Cronaflex print may contain small amounts of tape used for adjustments or corrections. These Cronaflex prints should be returned to Washington University following their use in preparing reductions.

X. Artwork Identification:

All artwork is identified by a number appearing on the artwork within the region that will be reproduced on the circuit board, Artwork for each layer of a circuit board bears a number, typically, in the form XXX NNN-N, where X designates letters A through Z and N designates numbers 0 through 9. All letters and numbers of this group are significant and should correspond exactly on the

artwork for each of the layers of a specific board. Two additional characters will follow the above identifying number. They are used to specify the artwork of the layers. The designations L1, L2, L3, L4, specify the artwork orientation as shown in Figures 1 and 2.

XI. Board finish:

When specified, the component side of the circuit board will have a screened pattern for component identification applied. The material applied shall be non-conductive, permanent, and resistant to materials and procedures used in board assembly, inspection, and cleaning.

Delivered circuit boards shall be free of scratches, abrasions, other physical damage, and contamination by foreign substances or residues. Any damage that exposes copper underlying solder plating is cause for board rejection.

XII. Board packaging:

Circuit boards shall be shipped in individual plastic covers to prevent contact between the surfaces of adjoining circuit boards and to protect board from abrasion. They shall be secured so as to prevent slipping against one another during shipment.

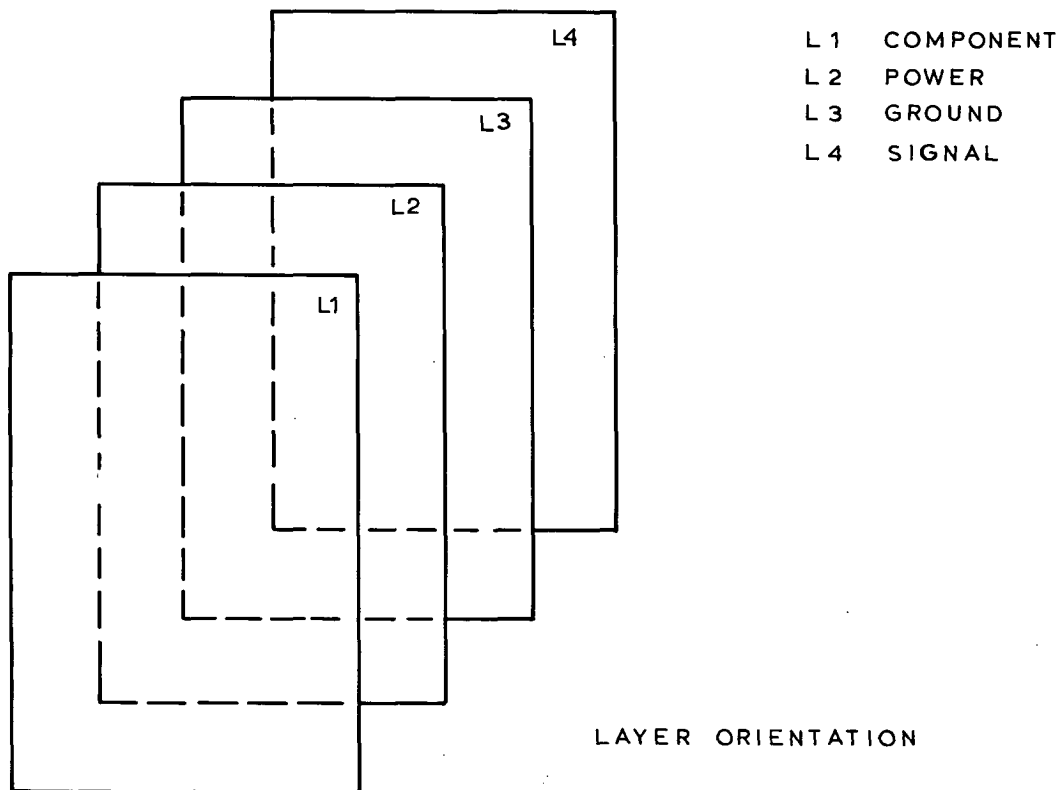
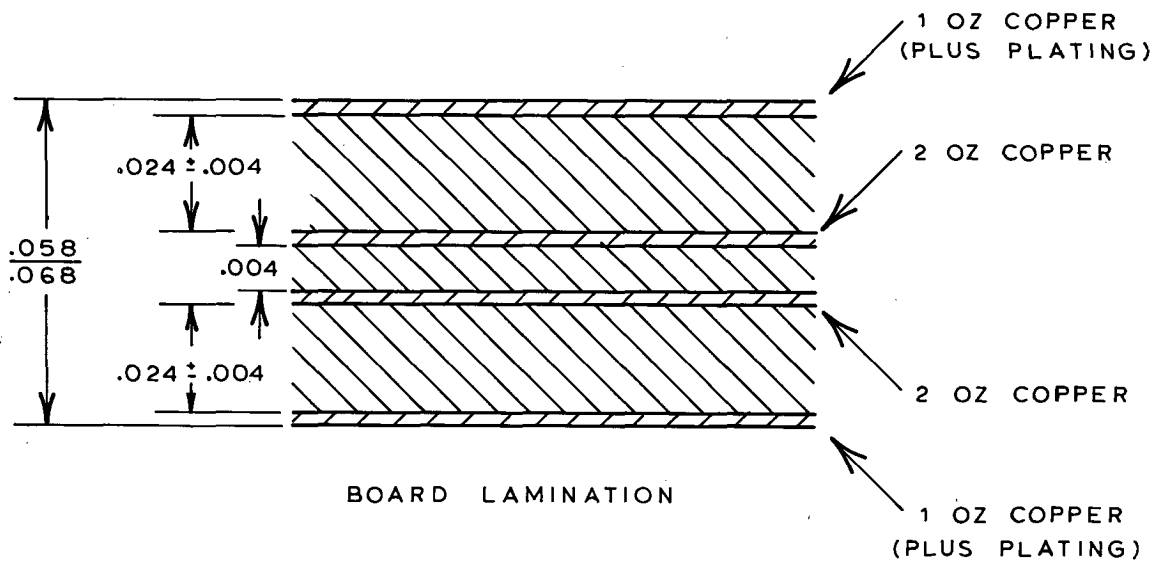

FIGURE 1
4 LAYER BOARD CONSTRUCTION

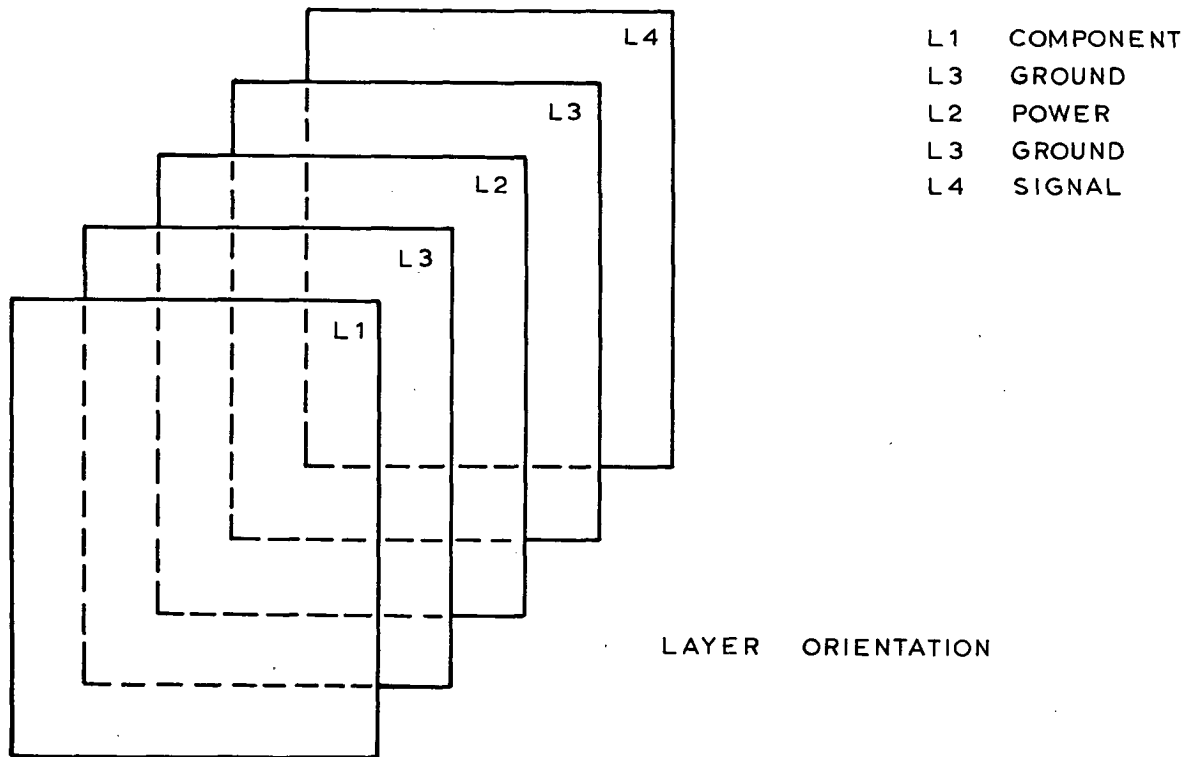
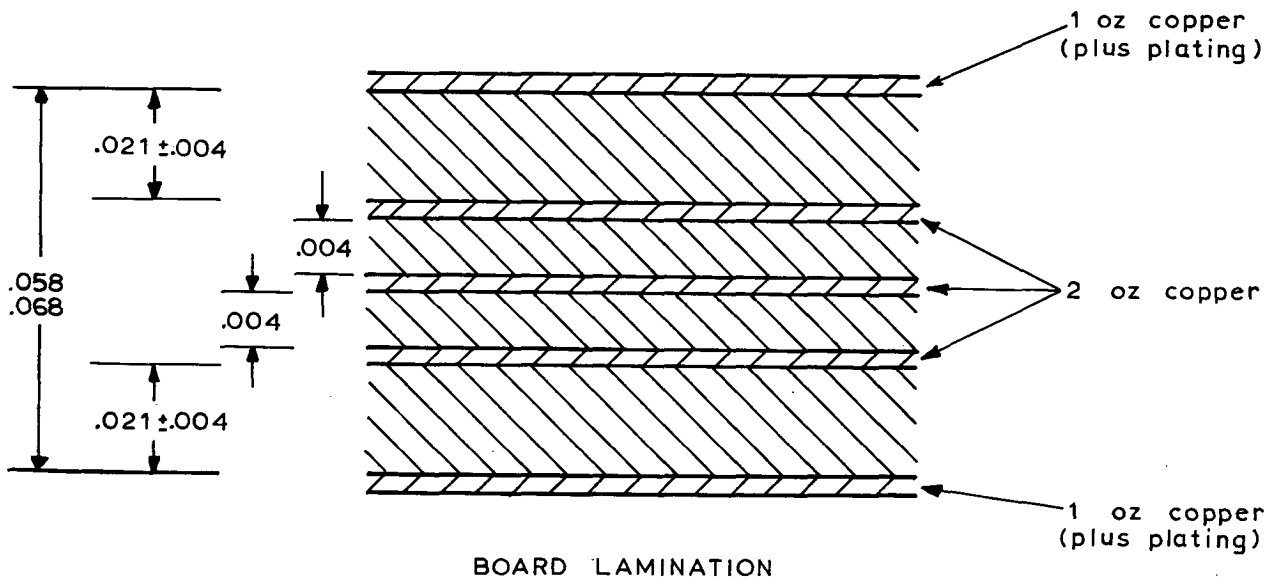

FIGURE 2
5 LAYER BOARD CONSTRUCTION

COMPUTER SYSTEMS LABORATORY
WASHINGTON UNIVERSITY

012

SYSTEM MAINTENANCE

PAGE	TITLE	CHANGE
012-1	TITLE PAGE	D
012-2	TITLE PAGE (cont)	
012-3	INTRODUCTION	
012-4	REAR CONNECTOR	
012-5	TYPE 1 FACEPLATE SUB SUBASSEMBLY	
012-6 thru 012-12	TYPE 1 WIRING LIST (LOGIC, ADDITION, SHIFT, LOAD AND COMPARE)	A C
012-13	TYPE 2 FACEPLATE SUB SUBASSEMBLY	
012-13A	TYPE 2 TO MERGE OR CALL MAP	B
012-14 thru 012-20	TYPE 2 WIRING LIST (DECISION CALL)	A
012-21 thru 012-27	TYPE 2 WIRING LIST (MERGE/RENDEZVOUS BRANCH)	
012-28	TYPE 3 FACEPLATE SUB SUBASSEMBLY	
012-29 thru 012-35	TYPE 3 WIRING LIST (REGISTER)	
012-36	TYPE 4 FACEPLATE SUB SUBASSEMBLY	
012-37 thru 012-42	TYPE 4 WIRING LIST (DECODER)	
012-43	TYPE 5 FACEPLATE SUB SUBASSEMBLY	
012-44 thru 012-52	TYPE 5 WIRING LIST (DATA BRANCH)	
012-53	TYPE 6 FACEPLATE SUB SUBASSEMBLY	
012-54 thru 012-57	TYPE 6 WIRING LIST (DIGITAL TO ANALOG D/A)	

CHG.	E.C.O.	DATE	APPR	CHG.	E.C.O.	DATE	APPR	CHG.	E.C.O.	DATE	APPR.
ISSUE	---	4-5-71	<i>RCJ</i>								
A	0229	11-16-71	<i>RJA</i>								
B	0233	11-24-71	<i>UMKP</i>								
C	0247	1-13-72	<i>RJA</i>								
D	0286	3-22-73	<i>RCJ</i>								

MACROMODULAR SYSTEMS PROJECT

SYSTEM MAINTENANCE

(cont.)

PAGE	TITLE	CHANGE
012-58	Pin Assignments Fan-Center Channel Connector	D
012-59	Pin Assignments Lateral Channel to Module	D
012-60	Lateral Channel Connector Numbering	D

CHG.	E.C.O.	DATE	APPR	CHG.	E.C.O.	DATE	APPR	CHG.	E.C.O.	DATE	APPR.
D	0286	2-28-73	<i>rcj</i>								

INTRODUCTION

This is a collection of documents which should aid in tracing wiring paths through Faceplate Boxes. Each of the Faceplate Box types is represented by a wiring list on which all connections are given their logic names and wire colors. A picture of the rear connectors is included here for convenience, and a picture of the front panel of each type of Faceplate Box immediately precedes the corresponding wiring list.

When probing with an ohm meter - PLEASE USE GOLD CONTACTS. An appropriate mating contact should always be inserted, rather than a probe tip or copper wire.

For Astro-348 Connectors, use the loose piece male or female contact. For the Blue Amp Box Connectors, use an AMP-MODU male pin. Control connectors require the use of an ohm meter probe tip - but be sure the tip touches only the outer portion of the contact.

Refer to other Faceplate Box documents (300 series) for information not contained here.

CHG	ECO	DATE	APPR.
ISSUE	—	4-15-71	<i>gcj</i>

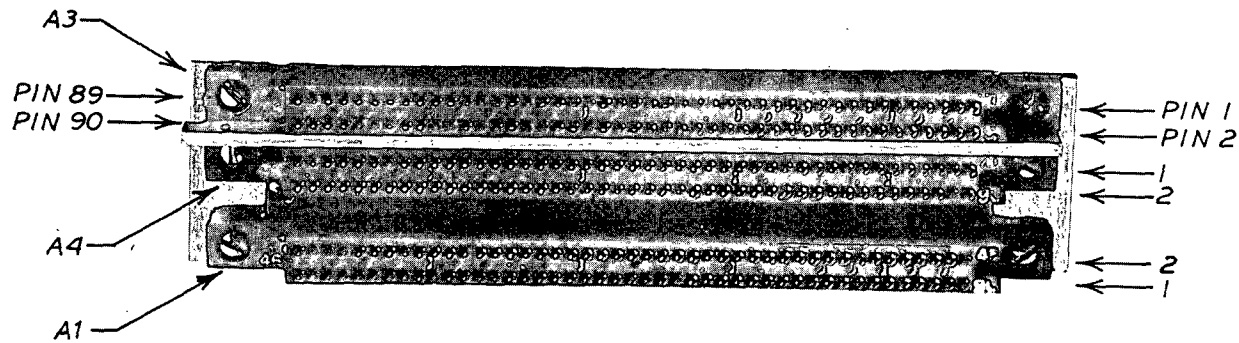

			COMPUTER SYSTEMS LABORATORY WASHINGTON UNIVERSITY ST. LOUIS, MISSOURI		TITLE REAR CONNECTORS			
			MACROMODULAR PROJECT		APPROVED BY <i>rcj</i> FOR MAINT. DATE 4-15-71		ENG. WAC DRAWN BY DHO	DRAWING NO. 012-4
CHANGE NO. ISSUE 4-2-71	DATE 4-2-71	DESCRIPTION <i>rcj</i>			CHECKED <i>rcj</i>		DATE 4-2-71	

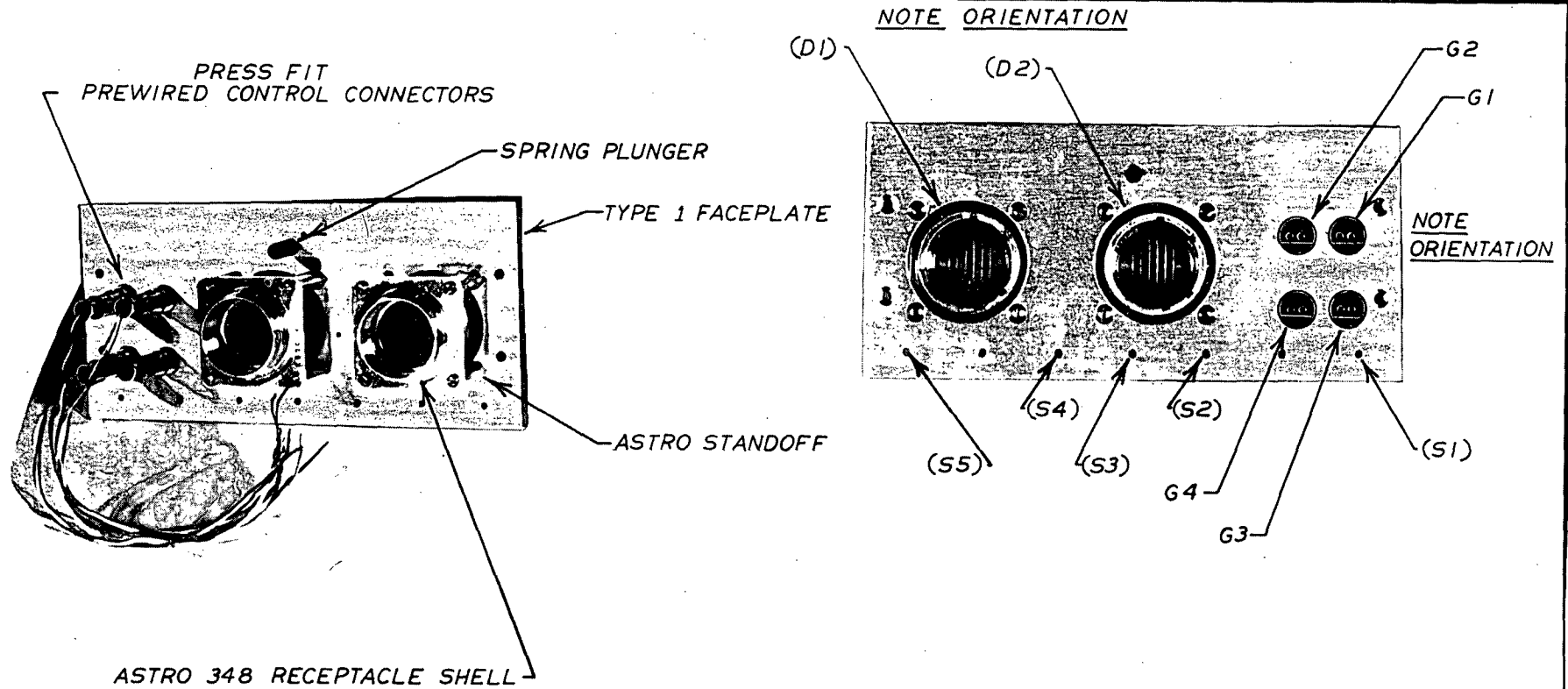

			COMPUTER SYSTEMS LABORATORY WASHINGTON UNIVERSITY ST. LOUIS, MISSOURI		TITLE TYPE 1 FACEPLATE SUB-SUBASSEMBLY	
			MACROMODULAR PROJECT		APPROVED FOR DATE BY <i>907</i> FOR MAINT. 4-15-71	
ISSUE 4-2-71 <i>907</i>					ENG. WAC DRAWN BY DHO	
CHANGE NO.	DATE	DESCRIPTION			CHECKED <i>907</i>	DATE 4-2-71

```

16A3 [ARG1 H FF
30D2 [BIT 1 H [ YELLOW
>>>>>>>>>>>>>>>
#
17A3 [ARG0 L FF
37D2 [BIT ZERO L [ ORANGE
#
18A3 [ARG0 H FF
36D2 [BIT ZERO H [ YELLOW
>>>>>>>>>>>>>>>
#
19A3 [GROUND
22D1 [GROUND [ BLUE
>>>>>>>>>>>>>>>
#
20A3 [GROUND
22D2 [GROUND [ BLUE
>>>>>>>>>>>>>>>
#
21A3 [MASK7 L FF
21D1 [BIT 7 L [ BROWN
#
22A3 [MASK7 H FF
20D1 [BIT 7 H [ YELLOW
#
>>>>>>>>>>>>>>>
23A3 [MASK6 L FF
17D1 [BIT 6 L [ GREEN
#
24A3 [MASK6 H FF
16D1 [BIT 6 H [ YELLOW
#
>>>>>>>>>>>>>>>
25A3 [MASK5 L FF
28D1 [BIT 5 L [ SLATE
#
26A3 [MASK5 H FF
27D1 [BIT 5 H [ WHITE
#
>>>>>>>>>>>>>>>
27A3 [MASK4 L FF
26D1 [BIT 4 L [ BROWN
#
28A3 [MASK4 H FF
25D1 [BIT 4 H [ RED
#
>>>>>>>>>>>>>>>
29A3 [ARG7 L FF
21D2 [BIT 7 L [ BROWN
#
30A3 [ARG7 H FF
20D2 [BIT 7 H [ YELLOW
#
>>>>>>>>>>>>>>>
31A3 [ARG6 L FF
17D2 [BIT 6 L [ GREEN
#

```

```

#       32A3 [ARG6 H FF
        16D2 [BIT 6 H [ YELLOW
#
>>>>>>>>>>>>>>>>>
#       33A3 [ARG5 L FF
        28D2 [BIT 5 L [ SLATE
#
        34A3 [ARG5 H FF
        27D2 [BIT 5 H [ WHITE
#
>>>>>>>>>>>>>>>>>
#       35A3 [ARG4 L FF
        26D2 [BIT 4 L [ BROWN
#
        36A3 [ARG4 H FF
        25D2 [BIT 4 H [ RED
        >>>>>>>>>>>>>>>>>
#
        37A3 [GROUND
        3G1 [ GROUND [ BLUE
        >>>>>>>>>>>>>>>>>
#
        38A3 [GROUND
        3G2 [ GROUND [ BLUE
        >>>>>>>>>>>>>>>>>
#
        39A3 [MASK11 L FF
        9D1 [BIT 11 L [ ORANGE
#
        40A3 [MASK11 H FF
        8D1 [BIT 11 H [ WHITE
#
>>>>>>>>>>>>>>>>>
#       41A3 [MASK10 L FF
        15D1 [BIT 10 L [ GREEN
#
        42A3 [MASK10 H FF
        14D1 [BIT 10 H [ RED
#
>>>>>>>>>>>>>>>>>
#       43A3 [MASK9 L FF
        13D1 [BIT 9 L [ GREEN
#
        44A3 [MASK9 H FF
        12D1 [BIT 9 H [ WHITE
#
>>>>>>>>>>>>>>>>>
#       45A3 [MASK8 L FF
        11D1 [BIT 8 L [ BROWN
#
        46A3 [MASK8 H FF
        10D1 [BIT 8 H [ WHITE
#
>>>>>>>>>>>>>>>>>
#       47A3 [ARG11 L FF
        9D2 [BIT 11 L [ ORANGE
#

```

```

48A3 [ARG11 H FF
8D2 [BIT 11 H [ WHITE
#
>>>>>>>>>>>>>>>>>>>>>>>>>
49A3 [ARG10 L FF
15D2 [BIT 10 L [ GREEN
#
50A3 [ARG10 H FF
14D2 [BIT 10 H [ RED
>>>>>>>>>>>>>>>>>>>>>>>>>
#
51A3 [GROUND
3G3 [ GROUND [ BLUE
#
>>>>>>>>>>>>>>>>>>>>>>>>>
52A3 [GROUND
3G4 [ GROUND [ BLUE
#
>>>>>>>>>>>>>>>>>>>>>>>>>
53A3 [ARG9 L FF
13D2 [BIT 9 L [ GREEN
#
54A3 [ARG9 H FF
12D2 [BIT 9 H [ WHITE
#
>>>>>>>>>>>>>>>>>>>>>>>>>
55A3 [ARG8 L FF
11D2 [BIT 8 L [ BROWN
#
56A3 [ARG8 H FF
10D2 [BIT 8 H [ WHITE
#
>>>>>>>>>>>>>>>>>>>>>>>>>
57A3 [C1 H TF
1G3 [ CONTROL HIGH [ WHITE
#
58A3 [C1 L TF
2G3 [ CONTROL LOW [ GREEN
#
>>>>>>>>>>>>>>>>>>>>>>>>>
59A3 [C2 H TF
1G4 [ CONTROL HIGH [ WHITE
#
60A3 [C2 L TF
2G4 [ CONTROL LOW [ BROWN
#
>>>>>>>>>>>>>>>>>>>>>>>>>
61A3 [DDR ARG H TF
18D2 [ DD RETURN H [ VIOLET
#
62A3 [DDR ARG L TF
19D2 [ DD RETURN L [ BLUE
#
>>>>>>>>>>>>>>>>>>>>>>>>>
63A3 [DDR MASK H TF
18D1 [ DD RETURN H [ VIOLET
#

```

64A3 [DDR MASK L TF
 19D1 [DD RETURN L [BLUE

 >>>>>>>>>>>>>>>>>>>>>>>>>

65A3 [GROUND [NO CONNECTION

 66A3 [GROUND [NO CONNECTION

 >>>>>>>>>>>>>>>>>>>>>>>>>

67A3 [I2 H FF
 1G2 [CONTROL HIGH [WHITE

 68A3 [I2 L FF
 2G2 [CONTROL LOW [ORANGE

 >>>>>>>>>>>>>>>>>>>>>>>>>

69A3 [I1 H FF
 1G1 [CONTROL HIGH [WHITE

 70A3 [I1 L FF
 2G1 [CONTROL LOW [BLUE

 >>>>>>>>>>>>>>>>>>>>>>>>>

71A3 [DD MASK H FF
 6D1 [D DELIVER H [VIOLET

 72A3 [DD MASK L FF
 7D1 [D DELIVER L [ORANGE

 >>>>>>>>>>>>>>>>>>>>>>>>>

73A3 [DD ARG H FF
 6D2 [D DELIVER H [VIOLET

 74A3 [DD ARG L FF
 7D2 [D DELIVER L [ORANGE

 >>>>>>>>>>>>>>>>>>>>>>>>>

75A3 [NO CONNECTION
 29D2 [CABLE SENSE [GREEN

 >>>>>>>>>>>>>>>>>>>>>>>>>

76A3 [NO CONNECTION
 29D1 [CABLE SENSE [GREEN

 >>>>>>>>>>>>>>>>>>>>>>>>>

[
 [TWO WIRES ARE SOLDERED TO PIN 77A3
 [

77A3 [POWER
 5D1 [POWER [YELLOW
 5D2 [POWER [YELLOW

 >>>>>>>>>>>>>>>>>>>>>>>>>

78A3 [GROUND [SIX INCH BLUE WIRE WITH GROUND LUG
 [CONNECT TO D1

 >>>>>>>>>>>>>>>>>>>>>>>>>

[ONE WIRE TO PIN 79A3 AND TWO WIRE CONNECTIONS ON EACH COMMON PIN OF THE SWITCHES

79A3 [CODE DRIVER H TF

1S1 [COMMON [YELLOW

1S2 [COMMON [YELLOW

1S3 [COMMON [YELLOW

1S4 [COMMON [YELLOW

1S5 [COMMON [YELLOW

#

[

80A3 [GROUND [SIX INCH BLUE WIRE WITH GROUND LUG

[CONNECT TO D2

#

81A3 [RMB H FF

2S1 [NORMAL CLOSED [RED

#

82A3 [GROUND [NO CONNECTION

#

83A3 [FN3 L FF

2S5 [NORMAL CLOSED [RED

#

84A3 [GROUND [NO CONNECTION

#

85A3 [FN2 L FF

2S4 [NORMAL CLOSED [RED

#

86A3 [GROUND [NO CONNECTION

#

87A3 [FN1 L FF

2S3 [NORMAL CLOSED [RED

#

88A3 [GROUND [NO CONNECTION

#

89A3 [FNO L FF

2S2 [NORMAL CLOSED [RED

#

90A3 [GROUND [NO CONNECTION

#

[

[THE FOLLOWING CONNECTIONS ARE RESISTORS WITH THEIR LEADS CRIMPED DIRECTLY INTO THE INDICATED CONNECTOR CONTACTS. THE EXPOSED PORTION OF THE LEADS SHALL BE COVERED BY TEFLON SLEEVING. THE COLOR CODE MAY BE IGNORED.

[

>>>>>>>>>>>>>>>>

1D1 [SPARE 1 [RED

1R601 [130 OHM RESISTOR

#

2D1 [SPARE 2 [SLATE

2R601 [130 OHM RESISTOR

#

>>>>>>>>>>>>>>>>

1D2 [SPARE 1 [RED

1R602 [130 OHM RESISTOR

#

2D2 [SPARE 2 [SLATE

2R602 [130 OHM RESISTOR

CHG.	E.C.O.	DATE	APPR.
A	0229	11/16/71	RJA
C	0247	1-13-72	RJA

PRESS-FIT PREWIRED
COAXICONS

SPRING PLUNGER

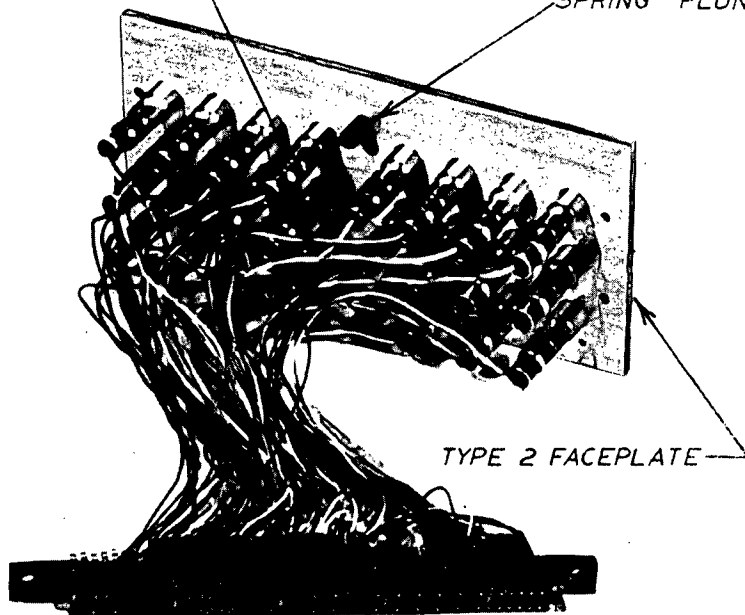

TYPE 2 FACEPLATE

FPB REAR CONNECTOR A3

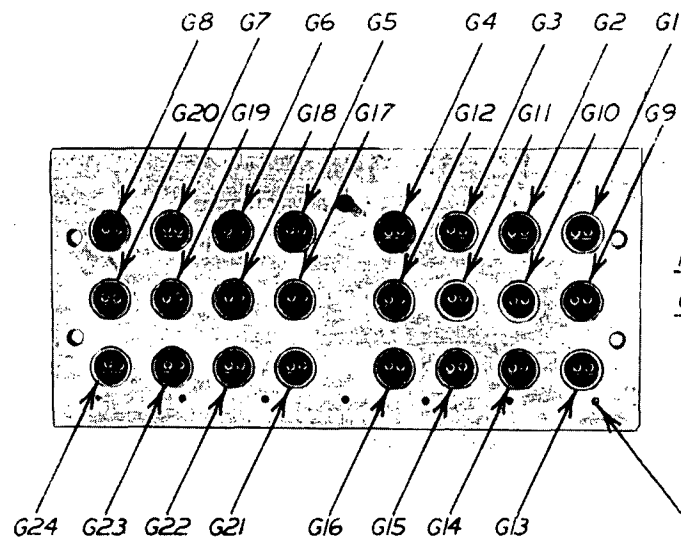

NOTE
ORIENTATION

ROLL PIN SUNK FLUSH
WITH REAR SURFACE

			COMPUTER SYSTEMS LABORATORY WASHINGTON UNIVERSITY ST. LOUIS, MISSOURI		TITLE TYPE 2 FACEPLATE SUB-SUBASSEMBLY				
			MACROMODULAR PROJECT		APPROVED			ENG. WAC	DRAWING NO. 012-13
ISSUE 4-2-71 <i>90f</i>					BY <i>90f</i>	FOR MAINT.	DATE 4-15-71	DRAWN BY DHO	
CHANGE NO.	DATE	DESCRIPTION						CHECKED <i>90f</i>	DATE 4-2-71

Type 2 to Merge or Call Map

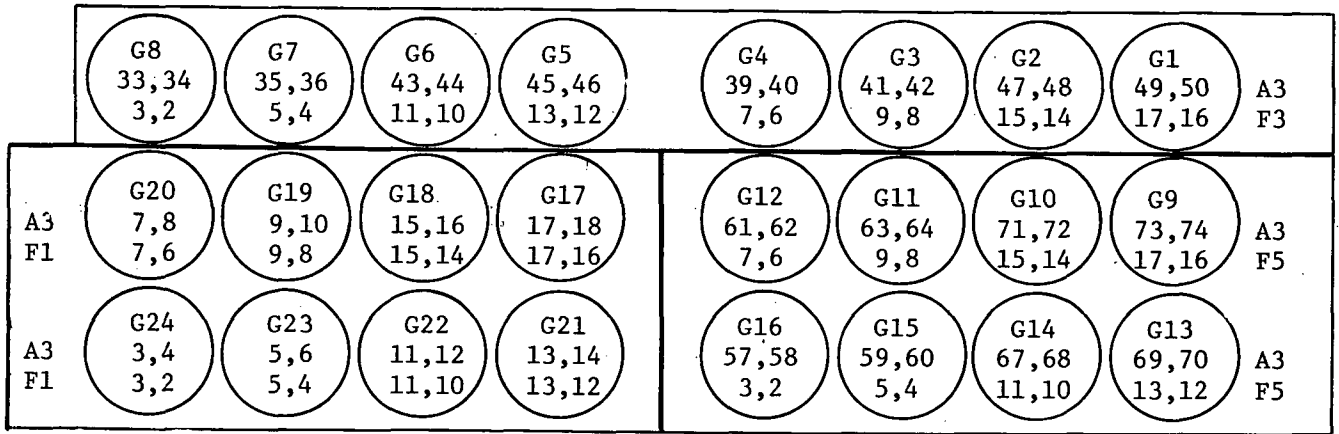

Map from Type II faceplate box (G1-G24), through PTF0091-1 motherboard (A3), to vertical boards (F1, F3, F5).

USE: to track a failure from a known faceplate location (G_) to the corresponding AMP-MODU on a logic drawing.

EXAMPLE:



1G15-59A3-5F5 HIGH } POLARITY FOR PRESET
2G15-60A3-4F5 LOW }

COAXICON PIN DESIGNATION

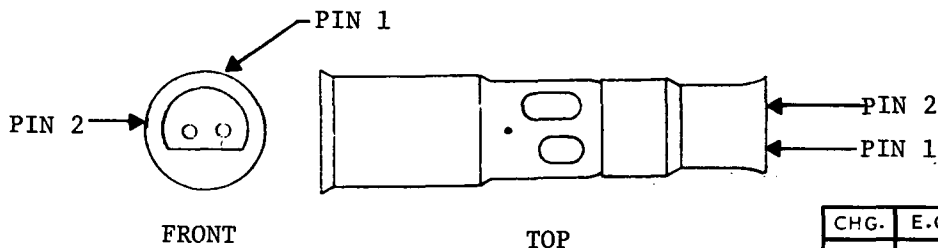

CHG.	E.C.O.	DATE	APPR.
B	0233	11-24-71	IMK P

```
#
  50A3  [I3B L FF
  2G1 [ CONTROL LOW [ BLUE
#
  >>>>>>>>>>>>>>>>
  51A3  [GROUND
  3G3 [ GROUND [ BLUE
  3G4 [ GROUND [ BLUE
#
  >>>>>>>>>>>>>>>>
  52A3  [GROUND
  3G11 [ BLUE
  3G12 [ BLUE
#
  >>>>>>>>>>>>>>>>
  53A3  [NO CONNECTION [NO CONNECTION
#
  54A3  [NO CONNECTION [NO CONNECTION
#
  55A3  [NO CONNECTION [NO CONNECTION
#
  56A3  [NO CONNECTION [NO CONNECTION
#
  >>>>>>>>>>>>>>>>
  57A3  [YB H FF
  1G16 [ YELLOW
#
  58A3  [YB L FF
  2G16 [ GREEN
#
  >>>>>>>>>>>>>>>>
  59A3  [Y1B H TF
  1G15 [ YELLOW
#
  60A3  [Y1B L TF
  2G15 [ ORANGE
#
  >>>>>>>>>>>>>>>>
  61A3  [NB H FF
  1G12 [ RED
#
  62A3  [NB L FF
  2G12 [ BROWN
#
  >>>>>>>>>>>>>>>>
  63A3  [N1B H TF
  1G11 [ RED
#
  64A3  [N1B L TF
  2G11 [ GREEN
#
  >>>>>>>>>>>>>>>>
  65A3  [GROUND
  3G15 [ BLUE
  3G16 [ BLUE
#
  >>>>>>>>>>>>>>>>
```

FPT2NC,6 LN=436

82A3 [GROUND [NO CONNECTION

83A3 [NO CONNECTION [NO CONNECTION

84A3 [GROUND [NO CONNECTION

85A3 [NO CONNECTION [NO CONNECTION

86A3 [GROUND [NO CONNECTION

87A3 [NO CONNECTION [NO CONNECTION

88A3 [GROUND [NO CONNECTION

89A3 [NO CONNECTION [NO CONNECTION

90A3 [GROUND [NO CONNECTION

[
[SWITCHES ARE WIRED WITH SINGLE WIRES
[

79A4 [NO CONNECTION

80A4
2S1 [NORMAL CLOSED [RED

81A4 [NO CONNECTION

82A4
2S2 [NORMAL CLOSED [RED

83A4 [NO CONNECTION

84A4
2S3 [NORMAL CLOSED [RED

86A4 [NO CONNECTION

87A4 [NO CONNECTION

88A4
1S1 [COMMON [YELLOW
1S2 [COMMON [YELLOW
1S3 [COMMON [YELLOW

89A4 [NO CONNECTION

[
[
[
[END OF WIRING LIST
[
[
[

[FPT2NC
[GERALD C JOHNS

CHG.	E.C.O.	DATE	APPR.
A	0229	11/16/77	RJA

FPT2NC,7 LN=527

[26 MARCH 1971

```

2G8 [ GREEN
#
>>>>>>>>>>>>>>>>>>>>>>
35A3 [I1D H FF
1G7 [ YELLOW
#
36A3 [I1D L FF
2G7 [ ORANGE
#
>>>>>>>>>>>>>>>>>>>>>>
37A3 [GROUND
3G17 [ BLUE
3G18 [ BLUE
#
>>>>>>>>>>>>>>>>>>>>>>
38A3 [GROUND
3G21 [ BLUE
3G22 [ BLUE
#
>>>>>>>>>>>>>>>>>>>>>>
39A3 [I2C H FF
1G4 [ CONTROL HIGH [ WHITE
#
40A3 [I2C L FF
2G4 [ CONTROL LOW [ BROWN
#
>>>>>>>>>>>>>>>>>>>>>>
41A3 [I1C H FF
1G3 [ CONTROL HIGH [ WHITE
#
42A3 [I1C L FF
2G3 [ CONTROL LOW [ GREEN
#
>>>>>>>>>>>>>>>>>>>>>>
43A3 [C2D H TF
1G6 [ YELLOW
#
44A3 [C2D L TF
2G6 [ BLUE
#
>>>>>>>>>>>>>>>>>>>>>>
45A3 [C1D H TF
1G5 [ WHITE
#
46A3 [C1D L TF
2G5 [ SLATE
#
>>>>>>>>>>>>>>>>>>>>>>
47A3 [C2C H TF
1G2 [ CONTROL HIGH [ WHITE
#
48A3 [C2C L TF
2G2 [ CONTROL LOW [ ORANGE
#
>>>>>>>>>>>>>>>>>>>>>>
49A3 [C1C H TF
1G1 [ CONTROL HIGH [ WHITE

```

```

#
50A3 [C1C L TF
2G1 [ CONTROL LOW [ BLUE
#
>>>>>>>>>>>>>>>>>>>>>>
51A3 [GROUND
3G3 [ GROUND [ BLUE
3G4 [ GROUND [ BLUE
#
>>>>>>>>>>>>>>>>>>>>>>
52A3 [GROUND
3G11 [ BLUE
3G12 [ BLUE
#
>>>>>>>>>>>>>>>>>>>>>>
53A3 [NO CONNECTION [NO CONNECTION
#
54A3 [NO CONNECTION [NO CONNECTION
#
55A3 [NO CONNECTION [NO CONNECTION
#
56A3 [NO CONNECTION [NO CONNECTION
#
>>>>>>>>>>>>>>>>>>>>>>
57A3 [I2F H FF
1G16 [ YELLOW
#
58A3 [I2F L FF
2G16 [ GREEN
#
>>>>>>>>>>>>>>>>>>>>>>
59A3 [I1F H FF
1G15 [ YELLOW
#
60A3 [I1F L FF
2G15 [ ORANGE
#
>>>>>>>>>>>>>>>>>>>>>>
61A3 [I2E H FF
1G12 [ RED
#
62A3 [I2E L FF
2G12 [ BROWN
#
>>>>>>>>>>>>>>>>>>>>>>
63A3 [I1E H FF
1G11 [ RED
#
64A3 [I1E L FF
2G11 [ GREEN
#
>>>>>>>>>>>>>>>>>>>>>>
65A3 [GROUND
3G15 [ BLUE
3G16 [ BLUE
#
>>>>>>>>>>>>>>>>>>>>>>

```



```
        66A3 [GROUND  
        3G1 [ GROUND [ BLUE  
        3G2 [ GROUND [ BLUE  
#  
>>>>>>>>>>>>>>>>>>>>>>  
        67A3 [C2F H TF  
        1G14 [ YELLOW  
#  
        68A3 [C2F L TF  
        2G14 [ BLUE  
#  
>>>>>>>>>>>>>>>>>>>>>>  
        69A3 [C1F H TF  
        1G13 [ RED  
#  
        70A3 [C1F L TF  
        2G13 [ SLATE  
#  
>>>>>>>>>>>>>>>>>>>>>>  
        71A3 [C2E H TF  
        1G10 [ RED  
#  
        72A3 [C2E L TF  
        2G10 [ ORANGE  
#  
>>>>>>>>>>>>>>>>>>>>>>  
        73A3 [C1E H TF  
        1G9 [ RED  
#  
        74A3 [C1E L TF  
        2G9 [ BLUE  
#  
>>>>>>>>>>>>>>>>>>>>>>  
        75A3 [NO CONNECTION [NO CONNECTION  
#  
        76A3 [NO CONNECTION [NO CONNECTION  
#  
>>>>>>>>>>>>>>>>>>>>>>  
        77A3 [POWER  
        90A4 [POWER [YELLOW  
#  
>>>>>>>>>>>>>>>>>>>>>>  
        78A3 [GROUND  
        3G9 [ BLUE  
        3G10 [ BLUE  
#  
>>>>>>>>>>>>>>>>>>>>>>  
        79A3 [NO CONNECTION [NO CONNECTION  
#  
>>>>>>>>>>>>>>>>>>>>>>  
        80A3 [GROUND  
        3G13 [ BLUE  
        3G14 [ BLUE  
#  
>>>>>>>>>>>>>>>>>>>>>>  
        81A3 [NO CONNECTION [NO CONNECTION  
#
```

FPT2NCM,6 LN=436

82A3 [GROUND [NO CONNECTION

83A3 [NO CONNECTION [NO CONNECTION

84A3 [GROUND [NO CONNECTION

85A3 [NO CONNECTION [NO CONNECTION

86A3 [GROUND [NO CONNECTION

87A3 [NO CONNECTION [NO CONNECTION

88A3 [GROUND [NO CONNECTION

89A3 [NO CONNECTION [NO CONNECTION

90A3 [GROUND [NO CONNECTION

[
[SWITCHES ARE WIRED WITH SINGLE WIRES
[

79A4 [GROUND [NO CONNECTION

80A4 [FNO L FF
3S1 [NORMAL CLOSED [RED

81A4 [GROUND [NO CONNECTION

82A4 [FN1 L FF
3S2 [NORMAL CLOSED [RED

83A4 [GROUND [NO CONNECTION

84A4 [FN2 L FF
3S3 [NORMAL CLOSED [RED

86A4 [NO CONNECTION [NO CONNECTION

87A4 [GROUND [NO CONNECTION

88A4 [CODE DRIVER H TF
1S1 [COMMON [YELLOW
1S2 [COMMON [YELLOW
1S3 [COMMON [YELLOW

89A4 [GROUND [NO CONNECTION

[
[END OF WIRING LIST
[

[FPT2NCM
[GERALD C JOHNS

FPT2NCM,7 LN=527

[26 MARCH 1971

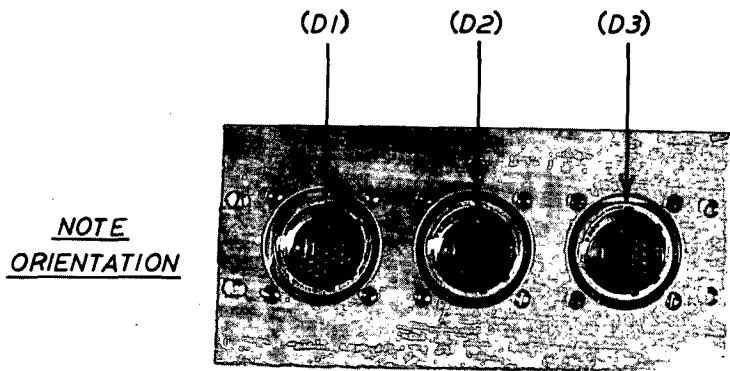

NOTE
ORIENTATION

TYPE 3 FACEPLATE

ASTRO STANDOFF

SPRING PLUNGER



ASTRO 348 RECEPTACLE SHELLS

		COMPUTER SYSTEMS LABORATORY WASHINGTON UNIVERSITY ST. LOUIS, MISSOURI		TITLE TYPE 3 FACEPLATE SUB-SUBASSEMBLY	
		MACROMODULAR PROJECT		APPROVED	
ISSUE 4-2-71 <i>gcf</i>				BY <i>gcf</i>	FOR MAINT.
CHANGE NO.	DATE	DESCRIPTION		CHECKED <i>gcf</i>	DRAWING NO. 012-28
				DATE 4-2-71	

[TYPE THREE FACEPLATE BOX WIRING LIST

```

[
[
>>>>>>>>>>>>>>>>>>>>>>>>>>>>
#
1A3 [GROUND [NO CONNECTION
#
>>>>>>>>>>>>>>>>>>>>>>>>>>>>
#
2A3 [GROUND [NO CONNECTION
#
>>>>>>>>>>>>>>>>>>>>>>>>>>>>
#
3A3 [R3 L TF
24D1 [BIT 3 L [ ORANGE
#
4A3 [R3 H TF
23D1 [BIT 3 H [ RED
#
>>>>>>>>>>>>>>>>>>>>>>>>>>>>
#
5A3 [R2 L TF
33D1 [BIT 2 L [ BLUE
#
6A3 [R2 H TF
32D1 [BIT 2 H [ RED
#
>>>>>>>>>>>>>>>>>>>>>>>>>>>>
#
7A3 [R1 L TF
31D1 [BIT 1 L [ SLATE
#
8A3 [R1 H TF
30D1 [BIT 1 H [ YELLOW
#
>>>>>>>>>>>>>>>>>>>>>>>>>>>>
#
9A3 [R0 L TF
37D1 [BIT ZERO L [ ORANGE
#
10A3 [R0 H TF
36D1 [BIT ZERO H [ YELLOW
#
>>>>>>>>>>>>>>>>>>>>>>>>>>>>
#
11A3 [R3 L TF
24D2 [BIT 3 L [ ORANGE
#
12A3 [R3 H TF
23D2 [BIT 3 H [ RED
#
>>>>>>>>>>>>>>>>>>>>>>>>>>>>
#
13A3 [R2 L TF
33D2 [BIT 2 L [ BLUE
#
14A3 [R2 H TF
32D2 [BIT 2 H [ RED
#
>>>>>>>>>>>>>>>>>>>>>>>>>>>>
#
15A3 [R1 L TF
31D2 [BIT 1 L [ SLATE
#
16A3 [R1 H TF
  
```

CHG	E.C.O	DATE	APPR.
ISSUE	—	4-15-71	<i>gcj</i>

```
#
  30D2 [BIT 1 H [ YELLOW
>>>>>>>>>>>>>>>>>>>
  17A3 [R0 L TF
  37D2 [BIT ZERO L [ ORANGE
#
  18A3 [R0 H TF
  36D2 [BIT ZERO H [ YELLOW
#
>>>>>>>>>>>>>>>>>>>
  19A3 [GROUND
  22D1 [GROUND [ BLUE
#
  20A3 [GROUND
  22D2 [GROUND [ BLUE
#
>>>>>>>>>>>>>>>>>>>
  21A3 [R7 L TF
  21D1 [BIT 7 L [ BROWN
#
  22A3 [R7 H TF
  20D1 [BIT 7 H [ YELLOW
#
>>>>>>>>>>>>>>>>>>>
  23A3 [R6 L TF
  17D1 [BIT 6 L [ GREEN
#
  24A3 [R6 H TF
  16D1 [BIT 6 H [ YELLOW
#
>>>>>>>>>>>>>>>>>>>
  25A3 [R5 L TF
  28D1 [BIT 5 L [ SLATE
#
  26A3 [R5 H TF
  27D1 [BIT 5 H [ WHITE
#
>>>>>>>>>>>>>>>>>>>
  27A3 [R4 L TF
  26D1 [BIT 4 L [ BROWN
#
  28A3 [R4 H TF
  25D1 [BIT 4 H [ RED
#
>>>>>>>>>>>>>>>>>>>
  29A3 [R7 L TF
  21D2 [BIT 7 L [ BROWN
#
  30A3 [R7 H TF
  20D2 [BIT 7 H [ YELLOW
#
>>>>>>>>>>>>>>>>>>>
  31A3 [R6 L TF
  17D2 [BIT 6 L [ GREEN
#
  32A3 [R6 H TF
  16D2 [BIT 6 H [ YELLOW
```

```

#
>>>>>>>>>>>>>>>>>>
33A3 [R5 L TF
28D2 [BIT 5 L [ SLATE
#
34A3 [R5 H TF
27D2 [BIT 5 H [ WHITE
#
>>>>>>>>>>>>>>>>>>
35A3 [R4 L TF
26D2 [BIT 4 L [ BROWN
#
36A3 [R4 H TF
25D2 [BIT 4 H [ RED
#
>>>>>>>>>>>>>>>>>>
37A3 [GROUND [NO CONNECTION
#
38A3 [GROUND [NO CONNECTION
#
>>>>>>>>>>>>>>>>>>
39A3 [R11 L TF
9D1 [BIT 11 L [ ORANGE
#
40A3 [R11 H TF
8D1 [BIT 11 H [ WHITE
#
>>>>>>>>>>>>>>>>>>
41A3 [R10 L TF
15D1 [BIT 10 L [ GREEN
#
42A3 [R10 H TF
14D1 [BIT 10 H [ RED
#
>>>>>>>>>>>>>>>>>>
43A3 [R9 L TF
13D1 [BIT 9 L [ GREEN
#
44A3 [R9 H TF
12D1 [BIT 9 H [ WHITE
#
>>>>>>>>>>>>>>>>>>
45A3 [R8 L TF
11D1 [BIT 8 L [ BROWN
#
46A3 [R8 H TF
10D1 [BIT 8 H [ WHITE
#
>>>>>>>>>>>>>>>>>>
47A3 [R11 L TF
9D2 [BIT 11 L [ ORANGE
#
48A3 [R11 H TF
8D2 [BIT 11 H [ WHITE
#
>>>>>>>>>>>>>>>>>>
49A3 [R10 L TF

```



```

>>>>>>>>>>>>>>>>
85A3 [FN2 L FF
33D3 [BIT 2 L [ BLUE
#
86A3 [FN2 H FF
32D3 [BIT 2 H [ RED
#
>>>>>>>>>>>>>>>>
87A3 [FN1 L FF
31D3 [BIT 1 L [ SLATE
#
88A3 [FN1 H FF
30D3 [BIT 1 H [ YELLOW
#
>>>>>>>>>>>>>>>>
89A3 [FNO L FF
37D3 [BIT ZERO L [ ORANGE
#
90A3 [FNO H FF
36D3 [BIT ZERO H [ YELLOW
#
>>>>>>>>>>>>>>>>

```

[THE FOLLOWING CONNECTIONS ARE RESISTORS WITH THEIR LEADS CRIMPED DIRECTLY INTO THE INDICATED CONNECTOR CONTACTS. THE EXPOSED PORTION OF THE LEADS SHALL BE COVERED BY TEFLON SLEEVING. THE COLOR CODE MAY BE IGNORED.

```

1D1 [SPARE 1 [ RED
1R601 [ 130 OHM RESISTOR
#
2D1 [SPARE 2 [ SLATE
2R601 [ 130 OHM RESISTOR
#
>>>>>>>>>>>>>>>>
1D2 [SPARE 1 [ RED
1R602 [ 130 OHM RESISTOR
#
2D2 [SPARE 2 [ SLATE
2R602 [ 130 OHM RESISTOR
#
>>>>>>>>>>>>>>>>
3D1 [SPARE 3 [ YELLOW
1R603 [ 130 OHM RESISTOR
#
4D1 [SPARE 4 [ BLUE
2R603 [ 130 OHM RESISTOR
#
>>>>>>>>>>>>>>>>
3D2 [SPARE 3 [ YELLOW
1R604 [ 130 OHM RESISTOR
#
4D2 [SPARE 4 [ BLUE
2R604 [ 130 OHM RESISTOR
#
>>>>>>>>>>>>>>>>
34D1 [SPARE 5 [ WHITE

```

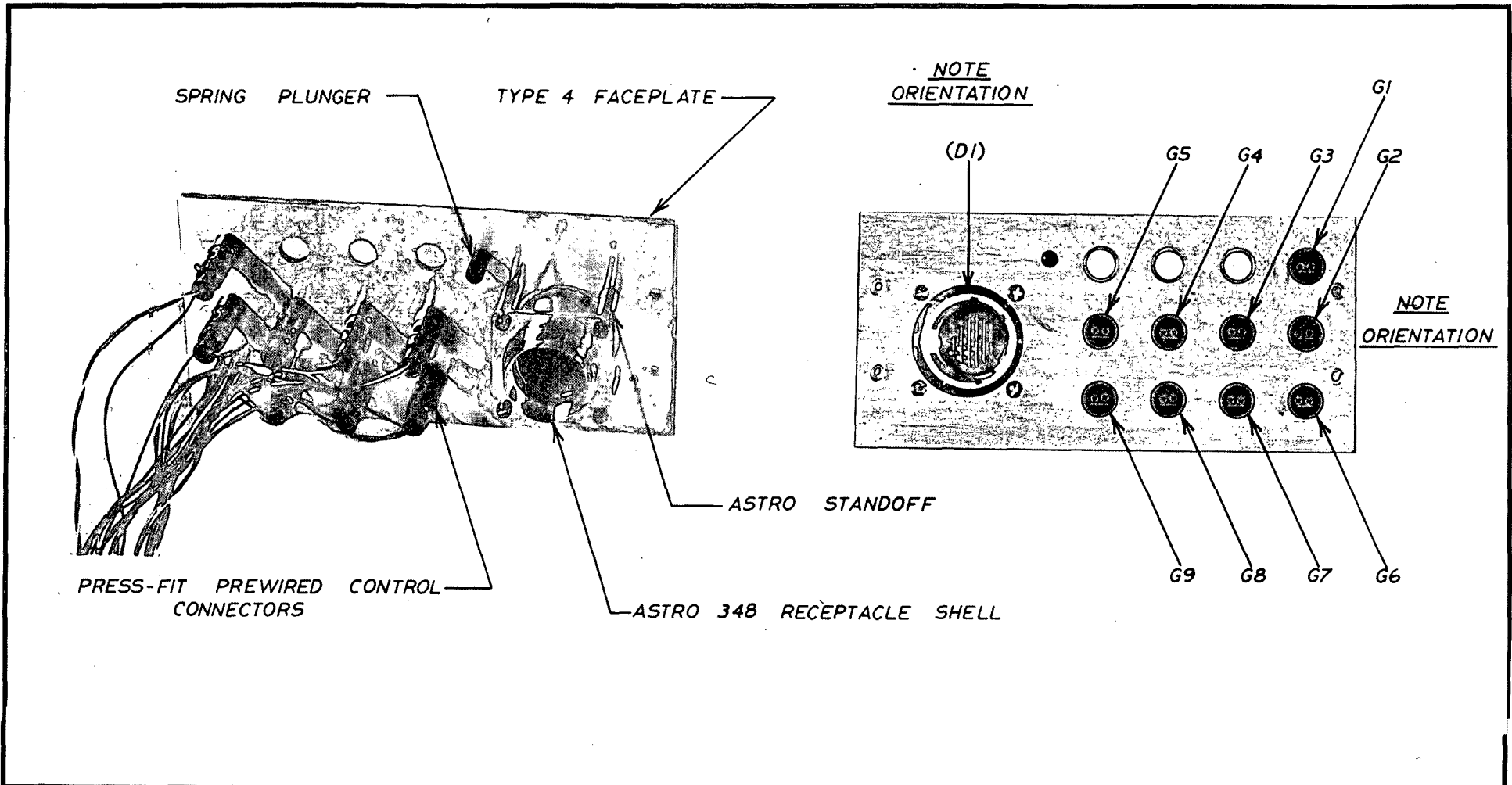
			COMPUTER SYSTEMS LABORATORY WASHINGTON UNIVERSITY ST. LOUIS, MISSOURI		TITLE TYPE 4 FACEPLATE SUB-SUBASSEMBLY	
			MACROMODULAR PROJECT		APPROVED	
ISSUE 4-2-71 <i>gjc</i>					BY <i>gjc</i>	FOR MAINT
CHANGE NO.	DATE	DESCRIPTION			CHECKED <i>gjc</i>	DRAWING NO. 012-36
						DATE 4-2-71

[TYPE FOUR FACEPLATE BOX WIRING LIST

[
[

>>>>>>>>>>>>>>>>>>>>>>>>>>>>

1A3 [GRD [NO CONNECTION

>>>>>>>>>>>>>>>>>>>>>>>>>>>>
2A3 [GRD [NO CONNECTION

>>>>>>>>>>>>>>>>>>>>>>>>>>>>
3A3 [M3 L FF
24D1 [BIT 3 L [ORANGE

4A3 [M3 H FF
23D1 [BIT 3 H [RED

>>>>>>>>>>>>>>>>>>>>>>>>>>>>
5A3 [M2 L FF
33D1 [BIT 2 L [BLUE

6A3 [M2 H FF
32D1 [BIT 2 H [RED

>>>>>>>>>>>>>>>>>>>>>>>>>>>>
7A3 [M1 L FF
31D1 [BIT 1 L [SLATE

8A3 [M1 H FF
30D1 [BIT 1 H [YELLOW

>>>>>>>>>>>>>>>>>>>>>>>>>>>>
9A3 [M0 L FF
37D1 [BIT ZERO L [ORANGE

10A3 [M0 H FF
36D1 [BIT ZERO H [YELLOW

>>>>>>>>>>>>>>>>>>>>>>>>>>>>
11A3 [RO CONNECTION [NO CONNECTION

12A3 [NO CONNECTION [NO CONNECTION

13A3 [NO CONNECTION [NO CONNECTION

14A3 [NO CONNECTION [NO CONNECTION

15A3 [NO CONNECTION [NO CONNECTION

16A3 [NO CONNECTION [NO CONNECTION

17A3 [NO CONNECTION [NO CONNECTION

18A3 [NO CONNECTION [NO CONNECTION

>>>>>>>>>>>>>>>>>>>>>>>>>>>>
19A3 [GRD

CHG.	E.C.O.	DATE	APPR
ISSUE	---	4-15-71	<i>gcf</i>

```

#
>>>>>>>>>>>>>>>>
39A3 [M11 L FF
9D1 [BIT 11 L [ ORANGE
#
40A3 [M11 H FF
8D1 [BIT 11 H [ WHITE
#
>>>>>>>>>>>>>>>>
41A3 [M10 L FF
15D1 [BIT 10 L [ GREEN
#
42A3 [M10 H FF
14D1 [BIT 10 H [ RED
#
>>>>>>>>>>>>>>>>
43A3 [M9 L FF
13D1 [BIT 9 L [ GREEN
#
44A3 [M9 H FF
12D1 [BIT 9 H [ WHITE
#
>>>>>>>>>>>>>>>>
45A3 [M8 L FF
11D1 [BIT 8 L [ BROWN
#
46A3 [M8 H FF
10D1 [BIT 8 H [ WHITE
#
>>>>>>>>>>>>>>>>
47A3 [C0 H TF
1G2 [ CONTROL HIGH [ WHITE
#
48A3 [C0 L TF
2G2 [ CONTROL LOW [ ORANGE
#
>>>>>>>>>>>>>>>>
49A3 [C1 H TF
1G3 [ CONTROL HIGH [ WHITE
#
50A3 [C1 L TF
2G3 [ CONTROL LOW [ GREEN
#
>>>>>>>>>>>>>>>>
51A3 [GRD
3G4 [ GROUND [ BLUE
3G8 [ BLUE
#
>>>>>>>>>>>>>>>>
52A3 [GRD
3G3 [ GROUND [ BLUE
3G7 [ BLUE
#
>>>>>>>>>>>>>>>>
53A3 [C2 H TF
1G4 [ CONTROL HIGH [ WHITE
#

```



```

# 70A3 [I L FF
  2G1 [ CONTROL LOW [ BLUE
# >>>>>>>>>>>>>>>>>>>>>>>>>>>>
  71A3 [MD H FF
  6D1 [ D DELIVER H [ VIOLET
#
  72A3 [MD L FF
  7D1 [ D DELIVER L [ ORANGE
#
# >>>>>>>>>>>>>>>>>>>>>>>>>>>>
  73A3 [NO CONNECTION [NO CONNECTION
#
  74A3 [NO CONNECTION [NO CONNECTION
#
  75A3 [NO CONNECTION [NO CONNECTION
#
# >>>>>>>>>>>>>>>>>>>>>>>>>>>>
  76A3 [NO CONNECTION
  29D1 [CABLE SENSE [ GREEN
  >>>>>>>>>>>>>>>>>>>>>>>>>>>>
#
  77A3 [POWER
  5D1 [POWER [ YELLOW
#
# >>>>>>>>>>>>>>>>>>>>>>>>>>>>
  78A3 [GRD
  3G1 [ GROUND [ BLUE
#
# >>>>>>>>>>>>>>>>>>>>>>>>>>>>
  79A3 [NO CONNECTIONIOM [NO CONNECTION
  >>>>>>>>>>>>>>>>>>>>>>>>>>>>
#
  80A3 [GRD [ SIX INCH BLUE WIRE WITH GROUND LUG
  [CONNECT TO D1
#
# >>>>>>>>>>>>>>>>>>>>>>>>>>>>
  81A3 [NO CONNECTION [NO CONNECTION
#
# >>>>>>>>>>>>>>>>>>>>>>>>>>>>
  82A3 [GRD [NO CONNECTION.
#
# >>>>>>>>>>>>>>>>>>>>>>>>>>>>
  83A3 [NO CONNECTION [NO CONNECTION
#
# >>>>>>>>>>>>>>>>>>>>>>>>>>>>
  84A3 [GRD [NO CONNECTION
#
# >>>>>>>>>>>>>>>>>>>>>>>>>>>>
  85A3 [NO CONNECTION [NO CONNECTION
#
# >>>>>>>>>>>>>>>>>>>>>>>>>>>>
  86A3 [GRD [NO CONNECTION
#
# >>>>>>>>>>>>>>>>>>>>>>>>>>>>
  87A3 [NO CONNECTION [NO CONNECTION
#

```

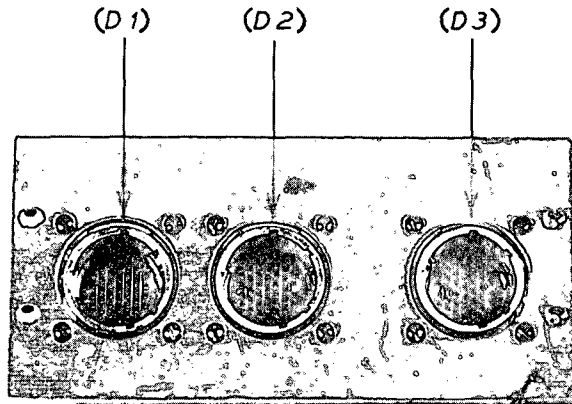

NOTE
ORIENTATION



TYPE 5 FACEPLATE

ASTRO STANDOFF

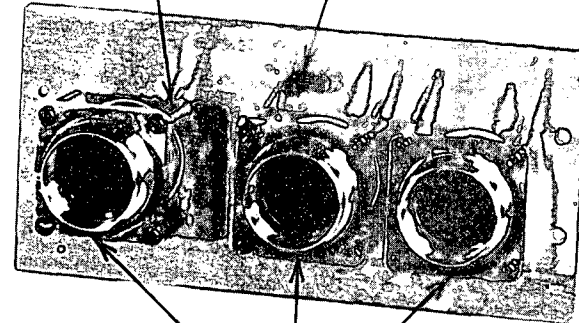
SPRING PLUNGER



ROLL PIN SUNK FLUSH
WITH REAR SURFACE

ASTRO 348 RECEPTACLE SHELLS

			COMPUTER SYSTEMS LABORATORY WASHINGTON UNIVERSITY ST. LOUIS, MISSOURI			TITLE TYPE 5 FACEPLATE SUB-SUBASSEMBLY			
			MACROMODULAR PROJECT			APPROVED BY <i>907</i> FOR MAINT. DATE 4-15-71		ENG. WAC	DRAWING NO. 012-43
ISSUE 4-2-71 <i>907</i>						CHECKED <i>907</i>		DRAWN BY DHO	
CHANGE NO.	DATE	DESCRIPTION							

[FPT5C
[FACEPLATE TYPE 5 WIRING LIST
[

>>>>>>>>>>>>>>>>

1A3 [GRD [SIX INCH WIRE WITH GROUND LUG
[CONNECT TO D1

>>>>>>>>>>>>>>>>

2A3 [GRD [SIX INCH WIRE WITH GROUND LUG
[CONNECT TO D2

>>>>>>>>>>>>>>>>

3A3 [B1-3 L TF
24D1 [BIT 3 L [ORANGE

4A3 [B1-3 H TF
23D1 [BIT 3 H [RED

>>>>>>>>>>>>>>>>
5A3 [B1-2 L TF
33D1 [BIT 2 L [BLUE

6A3 [B1-2 H TF
32D1 [BIT 2 H [RED

>>>>>>>>>>>>>>>>
7A3 [B1-1 L TF
31D1 [BIT 1 L [SLATE

8A3 [B1-1 H TF
30D1 [BIT 1 H [YELLOW

>>>>>>>>>>>>>>>>
9A3 [B1-0 L TF
37D1 [BIT ZERO L [ORANGE

10A3 [B1-0 H TF
36D1 [BIT ZERO H [YELLOW

>>>>>>>>>>>>>>>>
11A3 [B2-3 L TF
24D2 [BIT 3 L [ORANGE

12A3 [B2-3 H TF
23D2 [BIT 3 H [RED

>>>>>>>>>>>>>>>>
13A3 [B2-2 L TF
33D2 [BIT 2 L [BLUE

14A3 [B2-2 H TF
32D2 [BIT 2 H [RED

>>>>>>>>>>>>>>>>
15A3 [B2-1 L TF
31D2 [BIT 1 L [SLATE

CHG.	E.C.O.	DATE	APPR.
ISSUE	—	4-15-71	<i>gcj</i>

```

#
    16A3 [B2-1 H TF
    30D2 [BIT 1 H [ YELLOW
#
    >>>>>>>>>>>>>>>>
    17A3 [B2-0 L TF
    37D2 [BIT ZERO L [ ORANGE
#
    18A3 [B2-0 H TF
    36D2 [BIT ZERO H [ YELLOW
#
    >>>>>>>>>>>>>>>>
    19A3 [GRD
    22D1 [GROUND [ BLUE
#
    >>>>>>>>>>>>>>>>
    20A3 [GRD
    22D2 [GROUND [ BLUE
#
    >>>>>>>>>>>>>>>>
    21A3 [B1-7 L TF
    21D1 [BIT 7 L [ BROWN
#
    22A3 [B1-7 H TF
    20D1 [BIT 7 H [ YELLOW
#
    >>>>>>>>>>>>>>>>
    23A3 [B1-6 L TF
    17D1 [BIT 6 L [ GREEN
#
    24A3 [B1-6 H TF
    16D1 [BIT 6 H [ YELLOW
#
    >>>>>>>>>>>>>>>>
    25A3 [B1-5 L TF
    28D1 [BIT 5 L [ SLATE
#
    26A3 [B1-5 H TF
    27D1 [BIT 5 H [ WHITE
#
    >>>>>>>>>>>>>>>>
    27A3 [B1-4 L TF
    26D1 [BIT 4 L [ BROWN
#
    28A3 [B1-4 H TF
    25D1 [BIT 4 H [ RED
#
    >>>>>>>>>>>>>>>>
    29A3 [B2-7 L TF
    21D2 [BIT 7 L [ BROWN
#
    30A3 [B2-7 H TF
    20D2 [BIT 7 H [ YELLOW
#
    >>>>>>>>>>>>>>>>
    31A3 [B2-6 L TF
    17D2 [BIT 6 L [ GREEN

```

```

#
32A3 [B2-6 H TF
16D2 [BIT 6 H [ YELLOW
#
>>>>>>>>>>>>>>>>>>>>>>
33A3 [B2-5 L TF
28D2 [BIT 5 L [ SLATE
#
34A3 [B2-5 H TF
27D2 [BIT 5 H [ WHITE
#
>>>>>>>>>>>>>>>>>>>>>>
35A3 [B2-4 L TF
26D2 [BIT 4 L [ BROWN
#
36A3 [B2-4 H TF
25D2 [BIT 4 H [ RED
#
>>>>>>>>>>>>>>>>>>>>>>
37A3 [GRD [NO CONNECTION
#
>>>>>>>>>>>>>>>>>>>>>>
38A3 [GRD [NO CONNECTION
#
>>>>>>>>>>>>>>>>>>>>>>
39A3 [B1-11 L TF
9D1 [BIT 11 L [ ORANGE
#
40A3 [B1-11 H TF
8D1 [BIT 11 H [ WHITE
#
>>>>>>>>>>>>>>>>>>>>>>
41A3 [B1-10 L TF
15D1 [BIT 10 L [ GREEN
#
42A3 [B1-10 H TF
14D1 [BIT 10 H [ RED
#
>>>>>>>>>>>>>>>>>>>>>>
43A3 [B1-9 L TF
13D1 [BIT 9 L [ GREEN
#
44A3 [B1-9 H TF
12D1 [BIT 9 H [ WHITE
#
>>>>>>>>>>>>>>>>>>>>>>
45A3 [B1-8 L TF
11D1 [BIT 8 L [ BROWN
#
46A3 [B1-8 H TF
10D1 [BIT 8 H [ WHITE
#
>>>>>>>>>>>>>>>>>>>>>>
47A3 [B2-11 L TF
9D2 [BIT 11 L [ ORANGE
#
48A3 [B2-11 H TF

```

8D2 [BIT 11 H [WHITE

>>>>>>>>>>>>>>>>>>
49A3 [B2-10 L TF
15D2 [BIT 10 L [GREEN

50A3 [B2-10 H TF
14D2 [BIT 10 H [RED

>>>>>>>>>>>>>>>>>>
51A3 [GRD [NO CONNECTION

>>>>>>>>>>>>>>>>>>
52A3 [GRD [NO CONNECTION

>>>>>>>>>>>>>>>>>>
53A3 [B2-9 L TF
13D2 [BIT 9 L [GREEN

54A3 [B2-9 H TF
12D2 [BIT 9 H [WHITE

>>>>>>>>>>>>>>>>>>
55A3 [B2-8 L TF
11D2 [BIT 8 L [BROWN

56A3 [B2-8 H TF
10D2 [BIT 8 H [WHITE

>>>>>>>>>>>>>>>>>>
57A3 [NO CONNECTION [NO CONNECTION

>>>>>>>>>>>>>>>>>>
58A3 [NO CONNECTION [NO CONNECTION

>>>>>>>>>>>>>>>>>>
59A3 [NO CONNECTION [NO CONNECTION

>>>>>>>>>>>>>>>>>>
60A3 [NO CONNECTION [NO CONNECTION

>>>>>>>>>>>>>>>>>>
61A3 [B2DDR H FF
18D2 [DD RETURN H [VIOLET

62A3 [B2DDR L FF
19D2 [DD RETURN L [BLUE

>>>>>>>>>>>>>>>>>>
63A3 [B1DDR H FF
18D1 [DD RETURN H [VIOLET

64A3 [B1DDR L FF
19D1 [DD RETURN L [BLUE

>>>>>>>>>>>>>>>>>>
65A3 [GRD [NO CONNECTION

```
# 1D1 [SPARE 1 [ RED
# 2R601 [ 130 OHM RESISTOR
2D1 [SPARE 2 [ SLATE
#
>>>>>>>>>>>>>>>>>>>>>>>>>>>>
1R602 [ 130 OHM RESISTOR
3D1 [SPARE 3 [ YELLOW
#
2R602 [ 130 OHM RESISTOR
4D1 [SPARE 4 [ BLUE
#
>>>>>>>>>>>>>>>>>>>>>>>>>>>>
1R603 [ 130 OHM RESISTOR
34D1 [SPARE 5 [ WHITE
#
2R603 [ 130 OHM RESISTOR
35D1 [SPARE 6 [ BLUE
#
>>>>>>>>>>>>>>>>>>>>>>>>>>>>
1R604 [ 130 OHM RESISTOR
1D2 [SPARE 1 [ RED
#
2R604 [ 130 OHM RESISTOR
2D2 [SPARE 2 [ SLATE
#
>>>>>>>>>>>>>>>>>>>>>>>>>>>>
1R605 [ 130 OHM RESISTOR
3D2 [SPARE 3 [ YELLOW
#
2R605 [ 130 OHM RESISTOR
4D2 [SPARE 4 [ BLUE
#
>>>>>>>>>>>>>>>>>>>>>>>>>>>>
1R606 [ 130 OHM RESISTOR
34D2 [SPARE 5 [ WHITE
#
2R606 [ 130 OHM RESISTOR
35D2 [SPARE 6 [ BLUE
#
>>>>>>>>>>>>>>>>>>>>>>>>>>>>
1R607
1D3 [SPARE 1 [ RED
#
2R607
2D3 [SPARE 2 [ SLATE
#
>>>>>>>>>>>>>>>>>>>>>>>>>>>>
1R608
3D3 [SPARE 3 [ YELLOW
#
2R608
4D3 [SPARE 4 [ BLUE
#
>>>>>>>>>>>>>>>>>>>>>>>>>>>>
1R609
34D3 [SPARE 5 [ WHITE
```

FPT5NC,11 LN=705

#

2R609
35D3 [SPARE 6 [BLUE

#

>>>>>>>>>>>>>>>>>>>>>>

[
[END OF WIRING LIST

[

[

[FPT5NC
[GERALD C JOHNS
[29 SEPT 1970

BLANK

COMPUTER SYSTEMS LABORATORY WASHINGTON UNIVERSITY ST. LOUIS, MISSOURI			MACROMODULAR PROJECT				
			TITLE TYPE 6 FACEPLATE SUB-SUBASSEMBLY				
			APPROVED			ENG	DRAWING NO.
			BY	FOR	DATE	DRAWN BY	012-53
						CHECKED	DATE
CHANGE NO.	DATE	DESCRIPTION					4-2-71

012-53

[FPT6C
[FACEPLATE TYPE 6 WIRING LIST

```

#
#
# 1A3 [NO CONNECTION
#
# >>>>>>>>>>>>>>>>>>>>>>>>>>>>
# 2A3 [GROUND
# 3V1 [BLUE
# >>>>>>>>>>>>>>>>>>>>>>>>>>>>
#
# 3A3 [NO CONNECTION
#
# >>>>>>>>>>>>>>>>>>>>>>>>>>>>
# 4A3 [NO CONNECTION
#
# >>>>>>>>>>>>>>>>>>>>>>>>>>>>
# 5A3 [ANALOG 0 OUT
# 1V1 [WHITE
#
# 6A3 [ANALOG 0 RETURN
# 2V1 [GREEN
#
# >>>>>>>>>>>>>>>>>>>>>>>>>>>>
# 7A3 [NO CONNECTION
#
# >>>>>>>>>>>>>>>>>>>>>>>>>>>>
# 8A3 [NO CONNECTION
#
# >>>>>>>>>>>>>>>>>>>>>>>>>>>>
# 9A3 [ NO CONNECTION
#
# >>>>>>>>>>>>>>>>>>>>>>>>>>>>
# 10A3 [GROUND
# 3V2 [BLUE
#
# >>>>>>>>>>>>>>>>>>>>>>>>>>>>
# 11A3 [NO CONNECTION
#
# >>>>>>>>>>>>>>>>>>>>>>>>>>>>
# 12A3 [NO CONNECTION
#
# >>>>>>>>>>>>>>>>>>>>>>>>>>>>
# 13A3 [ANALOG 1 OUT
# 1V2 [RED
#
# 14A3 [ANALOG 1 RETURN
# 2V2 [ORANGE
#
# >>>>>>>>>>>>>>>>>>>>>>>>>>>>
# 15A3 [GROUND
# 3G5 [BLUE
#
# >>>>>>>>>>>>>>>>>>>>>>>>>>>>
# 16A3 [GROUND
# 3G1 [GROUND [BLUE
  
```

CHG.	E.C.O.	DATE	APPR
ISSUE	—	4-15-71	<i>rcj</i>

FAN-CENTER CHANNEL CONNECTOR

Pin Assignments

1	Power + TL		47	NC
3	+		49	Power Down Request
5	+		51	Data Protect TR
7	+		53	Preset
9	+		55	Power Down Ack
11	+		57	Spare 1
13	+		59	Sense -
15	Power - TL		61	Sense +
17	-		63	Power - TR
19	-		65	-
21	-		67	-
23	-		69	-
25	-		71	-
27	-		73	-
29	Sense + TL		75	-
31	Sense - TL		77	Power + TR
33	Spare 1		79	+
35	Power Down Ack		81	+
37	Preset		83	+
39	Data Protect TL		85	+
41	Power Down Request TL		87	+
43	NC		89	+
45	NC			

SIC.	E.C.C.	DATE	APPR.
D	0286	2-28-73	<i>SCJ</i>

All even numbered pins are ground

Pin Assignments Lateral Channel to Module

	<u>Pin</u>	<u>Dir.</u>	<u>Name</u>					
Left side	1		F ₃					
	3		F ₂					
	5	L	F ₁					
	7		F ₀					
	9		INH					
	11		E _R					
	13	R	LMB					
	15		LFB					
	17		E _D					
	19	L	RDB	Add	Comp.	Load	Logic	Shift
	21		p11	---	---	---	---	---
	23	L	p12	C=0	---	---	---	BFR
	25		p13	---	C ₀	---	---	BFL
	27	R	p14	ITR	C ₀	ITR	ITR	RDY
	29	L	p15	C=1	C ₁	RDY	RDY	ITR
Common	31		power dn req					
	33		protect					
	35		pwr sns +					
	37		pwr sns -					
	39		preset					
	41		pwr dn ack					
	43		spare common					
	45		gnd					
	47		pwr -	} 0 VDC				
	49		pwr -					
	51		pwr -					
	53		pwr +	} 55 VDC				
	55		pwr +					
	57		pwr +					
	59		gnd	Add	Comp.	Load	Logic	Shift
Right side	61	L	p15	C=1	---	RDY	RDY	ITR
	63	R	p14	IRT	C ₁	ITR	ITR	RDY
	65		p13	---	C ₀	---	---	BFL
	67	L	p12	C=0	---	---	---	BFR
	69		p11	---	---	---	---	---
	71		RDB					
	73	L	E _D					
	75		LFB					
	77	R	LMB					
	79		E _R					
81		INH						
83		F ₀						
85	L	F ₁						
85		F ₂						
87		F ₃						

NOTE: All even numbered pins are ground.

CHG.	E.C.O.	DATE	APPR.
D	0286	2-28-73	<i>gof</i>

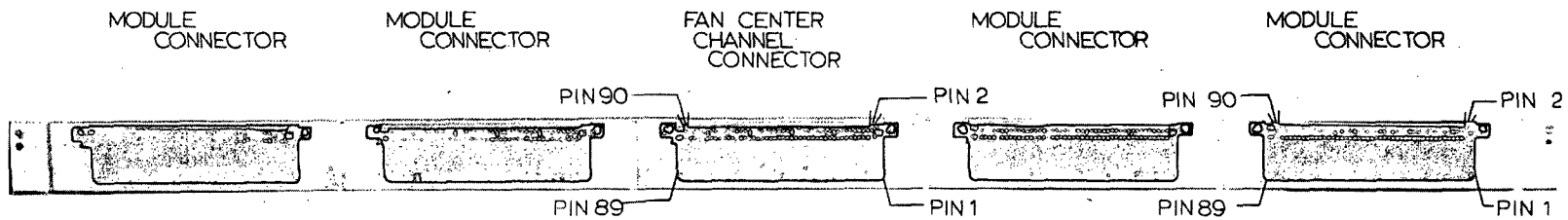

NOTE: SAME NUMBERING ON ALL MODULE CONNECTORS

		COMPUTER SYSTEMS LABORATORY WASHINGTON UNIVERSITY ST. LOUIS, MISSOURI		TITLE LATERAL CHANNEL CONNECTOR NUMBERING	
D	3-22-73	ECO 0286 <i>GCJ</i>	MACROMODULAR PROJECT		APPROVED
			BY <i>GCJ</i>		FOR MAINT.
				DATE 6-12-73	ENG. GCJ
				DRAWN BY DLS	DRAWING NO. 012-60
				CHECKED <i>GCJ</i>	DATE 4-16-73
CHANGE NO.	DATE	DESCRIPTION			

UNCLASSIFIED
Security Classification

DOCUMENT CONTROL DATA - R & D

(Security classification of title, body of abstract and indexing annotation must be entered when the overall report is classified)

1. ORIGINATING ACTIVITY (Corporate author) Computer Systems Laboratory Washington University St. Louis, Missouri		2a. REPORT SECURITY CLASSIFICATION UNCLASSIFIED	
		2b. GROUP	
3. REPORT TITLE GENERAL STANDARDS AND SYSTEM MAINTENANCE			
4. DESCRIPTIVE NOTES (Type of report and inclusive dates) Final Report 4/1/65 through 12/31/73			
5. AUTHOR(S) (First name, middle initial, last name) Norman T. Kinch, Editor			
6. REPORT DATE February, 1974		7a. TOTAL NO. OF PAGES 119	7b. NO. OF REFS
8a. CONTRACT OR GRANT NO. DOD (ARPA) Contract SD-302		9a. ORIGINATOR'S REPORT NUMBER(S) Volume 1 of Part 2	
b. PROJECT NO. ARPA Project Code No. 655		9b. OTHER REPORT NO(S) (Any other numbers that may be assigned this report) Technical Report No. 30	
c.			
d.			
10. DISTRIBUTION STATEMENT Distribution of this document is unlimited.			
11. SUPPLEMENTARY NOTES		12. SPONSORING MILITARY ACTIVITY ARPA - Information Processing Techniques, Washington, D.C.	
13. ABSTRACT Metal finishes, assembly specifications for printed circuit boards, standards for manufacture of printed circuit boards, description of electrical and mechanical properties of macromodular data and control cables, manufacturing specifications of Sprague LTN-2 and LTN-3 resistor networks, description and data sheets of BERNE, Inc. CTS 750 cermet resistor networks, wiring paths and pictorial assembly drawings of types of faceplate subassemblies are given.			

DD FORM 1473
1 NOV 65

REPLACES DD FORM 1473, 1 JAN 64, WHICH IS
OBSOLETE FOR ARMY USE.

UNCLASSIFIED
Security Classification

14. KEY WORDS	LINK A		LINK B		LINK C	
	ROLE	WT	ROLE	WT	ROLE	WT
Printed Circuit Boards						
Macromodules						
Metal Finishes						
Printed Circuit Standards						
Macromodule Assembly Specifications						
Macromodule Data Cable						
Macromodule Control Cable						
Macromodule Interlock Network						
Macromodule Faceplate Subassembly						
Macromodule Faceplate Wiring List						
Macromodule Pin Assignments						
Macromodule Lateral Channel						

