

From DEPARTMENT OF CLINICAL NEUROSCIENCE
DIVISION OF OPHTHALMOLOGY AND VISION
UNIT OF OPTOMETRY
Karolinska Institutet, Stockholm, Sweden

EFFECTS OF GLARE ON BINOCULAR VISION AND READING BEHAVIOUR PERFORMING COMPUTER WORK

Susanne Glimne



**Karolinska
Institutet**

Stockholm 2015

All previously published papers were reproduced with permission from the publisher.

Published by Karolinska Institutet.

Printed by Eprint AB 2015

© Susanne Glimne, 2015

ISBN 978-91-7549-655-9

EFFECTS OF GLARE ON BINOCULAR VISION AND
READING BEHAVIOUR PERFORMING COMPUTER
WORK
THESIS FOR DOCTORAL DEGREE (Ph.D.)

By

Susanne Glimne

Principal Supervisor:

Associate Professor
Rune L Brautaset
Karolinska Institutet
Department of Clinical Neuroscience
Division of Ophthalmology and Vision
Unit of Optometry

Opponent:

Associate Professor
Hans Richter
University of Gävle
Department of Occupational and Public Health
CBF, Center for Musculoskeletal Research

Co-supervisors:

PhD
Gustaf Öqvist Seimyr
Karolinska Institutet
Department of Clinical Neuroscience
Division of Ophthalmology and Vision

Examination Board:

Adjunct Professor
Mikael Forsman
Karolinska Institutet
Institute of Environmental Medicine
Unit of Occupational Medicine

Adjunct Professor
Kristina Teär Fahnehjelm
University of Gothenburg, Sahlgrenska Academy
Institute of Neuroscience and Physiology
Department of Clinical Neuroscience

Professor
Anna-Lisa Osvalder
Chalmers University of Technology
Department of Product and Production
Development
Division of Design & Human Factors

Associate Professor
Per Nylén
Royal Institute of Technology
School of Technology and Health
Division of Ergonomics

Associate Professor
Magne Helland
Buskerud and Vestfold University College
Faculty of Health Sciences
Department of Optometry and Visual Science

To my amazing son and daughter, with a patience beyond their years

And

To my dearest, always infinite being of love, light and endlessly supportive



The first book on occupational health,
“De Morbis Artificum Diatriba”,
included a chapter dedicated to
“illness of people working with small
objects”.

Author: Bernardino Ramazzini, 1739



ABSTRACT

We spend more and more time working with computers. When we do so our central visual field lacks three-dimensional (3D) features and this leads to reduced binocular control and may result in eye-related symptoms. When other factors such as direct and indirect glare are added to a computer work situation further stress is placed on the visual system and binocular control may be even further reduced and our reading behaviour may also be influenced. These factors are likely to contribute to the vision- and eye symptoms referred to collectively as computer vision syndrome (CVS).

Three areas of clinical study are included in the context of using a computer screen for demanding near visual tasks. This research aimed to explore the theoretical relationship between: (1) the importance of centrally placed 3D features in respect to accommodation and vergence mechanisms; (2) the influence of degraded stimuli and/or degraded retinal image on the quality of binocular vision as an indicator of visual fatigue; (3) the influence of degraded stimuli and/or degraded retinal image on eye movements when reading.

Paper I clarified the importance of implementing centrally placed 3D fixation stimuli to contribute to increase vergence accuracy and fixation stability. Paper II evaluated the influence of disability glare on binocular coordination. The results indicated that binocular coordination increased in instability with the severity of glare and there was a more pronounced effect when lighting condition created direct glare. Paper III described the influence of disability glare on eye movements when reading. It is clear that these eye movements were negatively affected in the direct- and indirect glare lighting conditions. Paper IV evaluated the threshold luminance of direct glare using a subjective response regarding eye symptoms in addition to an evaluation of the effect on binocular coordination as a benchmark. Direct glare of 2000 cd/m^2 was found to decrease the instability of binocular coordination with an increased level of eye pain.

In conclusion, these findings argue for a more pronounced relationship between reduced cues of centrally placed 3D features when working with computers with elevated exposure to disability glare. Direct glare appears to degrade the visibility of the retinal image to such a high degree that it can be identified as the most pronounced inappropriate lighting condition. Evaluation of the luminance threshold of direct glare suggests that it reasonable to recommend that stray light toward the eyes should be significantly lower than 2000 cd/m^2 . This research has taken a step in the direction of justifying the importance of following lighting design recommendations in computer work environments.

Keywords

Workplace luminance, Lighting conditions, Computer work, Vergence control, Fixation disparity, Reading, Eye movements

LIST OF PUBLICATIONS

- I. **Glimne S**, Öqvist Seimyr G, Brautaset RL. Effect of three-dimensional central stimuli on near point of convergence. (Accepted for publication in *Strabismus* April 29th 2015)
- II. **Glimne S**, Öqvist Seimyr G, Ygge J, Nylén P, Brautaset RL. Measuring glare induced visual fatigue by fixation disparity variation. *Work*. 2013;45(4):431–437.
- III. **Glimne S**, Brautaset RL, Öqvist Seimyr G. The effect of glare on eye movements when reading. *Work*. 2015;50(2):213–220.
- IV. **Glimne S**, Öqvist Seimyr G, Brautaset RL. Luminance treshold level in direct glare induced visual fatigue objectively measuring horizontal fixation disparity in addition to a subjective assessment of visual perception. (Manuscript)

ADDITIONAL SCIENTIFIC PUBLICATIONS

Favero F, **Glimne S**, Teär Fahnehjelm K, Eklund J. Kunskapsöversikt. Syn och belysning för äldre i arbetslivet. Report 2012:16. ISSN: 1650–3171. A report in Swedish on vision and lighting for older employees in workplaces published by the Swedish Work Environment Authority (Arbetsmiljöverket). 2012.

Glimne S, Törnquist AL, Nylén P, Eklund J, Teär Fahnehjelm K. Lighting and task analysis in an eye hospital. Proceedings of the 44th Annual Nordic Ergonomics Society Conference – Ergonomics for Sustainability and Growth, Saltsjöbaden, Sweden, 19–21 August 2012.

Teär Fahnehjelm K, Aronsson K, Ejhed J, Eklund J, Favero F, **Glimne S**, Moberg C, Nylén P, Törnquist AL. Belysning och utveckling av undersökningsrum. Multifunktionsrum i sjukvården. Rapport, S:t Eriks Ögonsjukhus och KTH. A report in Swedish on lighting in eye examination room in Eye hospitals supported by the Swedish Energy Agency. 2012. [<http://goo.gl/X2jSCV>].

Nylén P, Favero F, **Glimne S**, Teär Fahnehjelm K, Eklund J. Vision, light and aging: A literature overview on older-age workers. *Work*. 2014;47:399–412.

CONTENTS

1	Introduction	5
1.1	Aims of thesis	6
2	Background.....	7
2.1	Lighting condition and visual ability in work environment.....	9
2.1.1	The structures of the eye	9
2.1.2	Visual ability and target visibility.....	11
2.1.3	Photometry - The measurement of light.....	13
2.2	Theoretical framework	15
2.2.1	Accommodation and vergence mechanism.....	15
2.2.2	Fixation disparity (FD).....	16
2.2.3	Reading behaviour	18
3	Material and methods	20
3.1	Material/Data collection.....	20
3.2	Methods	21
3.3	Statistics	27
3.4	Ethics.....	27
4	Results.....	29
4.1	Paper I.....	29
4.2	Paper II.....	29
4.3	Paper III	30
4.4	Paper IV	32
5	Discussion.....	34
5.1	Clinical guidance	37
5.1.1	Computer workplace environment	37
5.1.2	Optometric considerations	37
5.1.3	Age related considerations	38
5.2	Future research	38
6	Conclusions	39
7	Acknowledgements	40
8	References	42
9	Supplementary work	50
10	Svensk populärvetenskaplig sammanfattning	53

LIST OF ABBREVIATIONS

AC	Accommodative Convergence
ANOVA	Analysis of Variance
AOA	American Optometric Association
ARMD	Age-Related Macular Degeneration
BCVA	Best Corrected Visual Acuity
CA	Convergence Accommodation
CVS	Computer Vision Syndrome
FD	Fixation Disparity
ICOH	International Commission on Occupational Health
IESNA	Illuminating Engineering Society of North America
IReST	International Readings Speed Text
LCD	Liquid Crystal Display
LGN	Lateral Geniculate Nucleus
LIX	Readability Index
NPC	Near Point of Convergence
RAF	Royal Air Force
SS-EN	The European Standard (EN) - has the status of a Swedish Standard (SS)
SWEA	Swedish Work Environment Authority
TFT	Thin-Film Transistor
VA	Visual Acuity
VDU	Visual Display Unit
VDT	Visual Display Terminal
WPM	Words Per Minute (reading speed)
2D	Two-Dimensional
3D	Three-Dimensional

1 INTRODUCTION

The main theme of this thesis is the evaluation of the influence of different, though commonly present, glare conditions in computer work environments on binocular control and reading behaviour. Although several studies have been devoted to the effect of induced glare in relation to disparity errors and reading behaviour in visual tasks while using a computer screen, rather less attention has been paid to the impact of glare, from inappropriate lighting design, on the capacity for binocular coordination and eye movements. When the central visual field lacks three-dimensional (3D) features, which is the case with computer work, it will cause reduced binocular control (Blythe et al., 2012). A reduced visibility, e.g. from inappropriate lighting design, will further add stress on the visual system (Jainta et al., 2011; Jaschinski-Kruza, 1994; Pickwell et al., 1987). These factors are likely to contribute to the vision- and eye symptoms referred to collectively as computer vision syndrome (CVS).

This thesis presents data from three areas of clinical studies in the context of using a computer screen for demanding near visual tasks. This research, using exploratory analyses, aimed to explore clinical hypotheses of the theoretical relationship between: (1) the importance of centrally placed three-dimensional (3D) features in respect to the accommodation and vergence mechanisms; (2) the influence of degraded stimuli and/or degraded retinal image on the quality of binocular vision as an indicator of visual fatigue; (3) the influence of degraded stimuli and/or degraded retinal image on eye movements when reading.

1.1 AIMS OF THESIS

This thesis comprises four clinical studies in the context of undertaking demanding visual tasks in a two-dimensional (2D) visual environment. The purpose of these investigations is to emphasize the impact of degradation of visibility on the capacity for binocular coordination and reading behaviour when working with computers.

More specific aims of the four studies were;

Paper I

To investigate the influence of binocular disparity on the vergence response through measurements of vergence ability with only two-dimensional features in the central field as compared to when three-dimensional features are available.

Paper II

To evaluate the effect of different glare conditions on vergence control while performing computer work through measurements of horizontal fixation disparity.

Paper III

To assess the effect of different glare conditions on eye movement patterns when reading from a computer screen through simultaneous objective measurements of eye movements.

Paper IV

To determine the threshold luminance value of direct glare while performing computer work through measurements of horizontal fixation disparity variance in addition to a subjective evaluation of eye-related symptoms.

2 BACKGROUND

We spend more and more time in front of the computer screen. Computer work involves demanding visual tasks in which the two eyes both need to be directed (converged) toward the same fixation point (since most people use both eyes simultaneously). A clear image of the screen should be projected on the retina of the eyes either through the capability the eye to change focus (a change of the power in the ocular lenses, i.e. accommodation) or by the use of refractive aids (e.g. contact lenses or glasses). Computer users often perform prolonged tasks which cause static ocular muscle load in combination with static load on the muscles of the neck and upper extremities. Computer screens only provide two-dimensional (2D) features in the central visual field because the screen is flat. In computer work environments light from other light sources than the screen (e.g. ceiling or desk luminaire, or the sun) also may enter the eyes either directly or through reflections from the computer screen or other surrounding surfaces. Accordingly, this glare will reduce the visibility of the task and/or the image on the retina.

In 2003 it was estimated that 55% of all employees in the USA used computers at work (U.S. Department of Labor, 2005), a number that is likely to have increased over the last 12 years. Similar figures apply also in Sweden. For women there has been an increase from 69.6 in 2005 to 81 percent in 2013, the equivalent increase for men was from 68.1 percent to 75 (The Work Environment, 2013). The incidence rate of musculoskeletal disorders in North America in clerical workers (private industry, state government, and local government) was 6.4 in 2013. The incidence rates represent the number of injuries and illnesses per 10,000 full-time workers. According to the Swedish Work Environment Authority (SWEA) work-related disorders due to working in front of monitors in 2012 were to be found in 2.3 (± 0.3) percent of the population of employed women, and 1.3 (± 0.2) percent of the population of employed men (Work-related disorders, 2012).

Using computers may cause work-related visual strain (occupational asthenopia) due to the fact that the visual demands of the task exceed the visual abilities of the individual (Sheedy & Shaw-McMinn, 2003). In less demanding visual tasks individuals are less likely to experience visual related strain. However, any work-related activity involving intense visual concentration might induce visual strain (Anshel, 2005). The American Optometric Association (AOA, 2015) describes computer vision syndrome (CVS) as eye- and vision-related problems that result from prolonged computer, tablet, e-reader and/or cell-phone use. The symptoms most commonly associated with CVS are eyestrain, headaches, blurred vision, dry eyes, and neck- and shoulder pain. Eyestrain is the major eye-related problem, defined as asthenopia. As a prediction for the future, Rosenfield (2011) concluded in a literature review that asthenopia due to oculomotor anomalies and dry eyes would account for a significant proportion of the number of visual display unit users with CVS presenting for an eye examination.

Research reports associated with visual strain in workers commonly have computer users as their study population. An early investigation (Rossignol et al., 1987) reported that the prevalence of visual symptoms increased among computer users who spent more than 4 hours per day in front of the computer screen. The prevalence of asthenopia among computer users has

been found over the past 20 years to be between 31 and 57% (Han et al., 2013; Portello et al., 2012; Bhandari et al., 2008; Mocci et al., 2001; Sanchez-Roman et al., 1996). Studies on visual symptoms, i.e. asthenopia, related to computer work have tended to divide the cause of asthenopia into two categories: (1) *external factors*, which include refractive anomalies, dry eyes (including the sensation of burning, irritation, ocular dryness and tearing); and (2) *internal factors*, which include the vergence and/or accommodation mechanism but also include headache, eye pain, diplopia and blur (Portello et al., 2012; Sheedy et al., 2003). Tyrell & Leibowitz (1990) included both categories of eyestrain in one broader category which they termed *visual fatigue*. Further, a recent study (Robertson et al., 2015) found a significant relationship between increased number of hours working with computers and visual discomfort including headaches.

There is a wealth of knowledge concerning age-related changes in visual functions among older workers. Disability glare increases with age (Ljspeert et al., 1991; Le Claire et al., 1982; Allen & Vos, 1967). A recent paper describes changes in visual function among elderly workers in relation to the need to continue professional careers after retirement (Nylén et al., 2014). The study suggested that deterioration of visual function might, secondarily, induce strained postures and musculoskeletal symptoms, pain and injury. A previous study has concluded that older subjects (age 50-82 years) are more sensitive to reduced visibility than younger subjects (age 15-41 years), probably due to a reduced visual acuity (VA) induced by increased scatter of the ocular media with age (Bailey & Bullimore, 1991). Moreover, Sheedy et al., (2005) found that older subjects (age 47-63 years) needed longer to complete computer task than younger subjects (age 23-39 years) because of slower adaptation to new brightness levels.

In a consensus document of the ICOH Committee (International Commission on Occupational Health) on “Work and Vision” Piccoli (2003) concluded that an integrated body of knowledge is required for trustworthy assessment of occupational asthenopia. In the document the author goes on to specify three essential prerequisites for a proper definition of an “occupational asthenopic syndrome”: (a) collecting research data related to the exposed population; (b) analysis of symptoms and subjective reports in relation to exposure conditions (task and environment); (c) adequate ophthalmic information on all the subjects involved.

One of the primary causes of glare associated with computer work is the use of wide angle luminaires (fluorescent lighting) which results in exposure to direct glare. In comparison with reading printed text, wide angle luminaires may cause direct glare because of the more horizontal (19-22° downward) direction of the gaze direction when working with a screen. Direct glare can also be caused by light entering through windows (Anshel, 2005). A recent study has focused on evaluating discomfort glare when using computers by comparing elderly subjects (aged 50 years or more) to younger subjects (i.e. younger than 35 years of age) (Wolska & Sawicki, 2014). Discomfort glare was evaluated in relation to a subjective assessment of discomfort glare on a glare rating scale, contrast and glare sensitivity, lighting quality, and asthenopic symptoms. The results showed that younger subjects more frequently suffered from visual fatigue (i.e. increased asthenopic symptoms) and assessed lighting as less comfortable.

However, glare sensitivity increased significantly after the experiments under both glare conditions in the 50+ group only. Furthermore, another study has studied perceived viewing distance, productivity (correct responses per minute) and font size while adding reflective glare when visually demanding text-based tasks are undertaken on a computer (Ko et al., 2014). They found that reflective glare on the monitor surface led to a reduced viewing distance but had no effect on productivity or accuracy.

Studies have determined an association between musculoskeletal complaints on upper extremities, i.e. in the neck- and shoulder region, and an increased level of oculomotor load due to visual stress in for instance tasks that demanded vision (Richter et al., 2011a, b; Li & Watten, 1987). Richter et al. (2011a) were the first group to show a significant relationship between the load on the ciliary muscle (through indirect measures), i.e. the eye-lens accommodation load, and static trapezius muscle activity. Furthermore, a cross-sectional study focusing on low vision patients suffering from age-related macular degeneration (ARMD) concluded that a reduced visual function is associated with muscular complaints in neck- and shoulder area (Zetterlund et al., 2009).

Further, Schiøtz Thorud et al. (2012) found that eyestrain during visually demanding computer tasks was related to the orbicularis oculi muscle and an increase in muscle blood flow. Moreover, recent research indicates a connection between close focus and increased muscle activity in the trapezius during dynamic focusing changes between near and far sight (Zetterberg et al., 2015). Other researchers have demonstrated an association between visual discomfort and shoulder-neck symptoms when performing computer tasks (Helland et al., 2008; Wiholm et al., 2007; Aarås et al., 2005; Horgen et al., 2005; Wahlström, et al., 2004; Aarås et al., 2001, 1998; Sauter et al., 1991). Accordingly there has been substantial research on computer work-station design in order to minimize discomfort and fatigue (Portello et al., 2013; Jaschinski, 2001, 1998; Turville et al., 1998; Jaschinski-Kruza, 1991; Sauter et al., 1991).

2.1 LIGHTING CONDITION AND VISUAL ABILITY IN WORK ENVIRONMENT

In order to understand general concepts included in this thesis this section provides an introductory background with descriptions and definitions with regard to illumination characteristics and visibility.

2.1.1 The structures of the eye

The eyeball's outermost layer is the tough and strong white sclera. Below this is the choroid which consists of blood vessels and connective tissue which supplies the retina. The retina comprises among other cell types, two forms of light receptors (rods and cones), see figure 1. The rods are more numerous, on average 92 million (Curcio et al., 1990), and more sensitive to light than the cones. However, they are not sensitive to colour and have a low spatial acuity. The 4 to 5.3 million cones provide the eye's colour sensitivity (Curcio et al., 1990), are responsible for high spatial acuity and they are much more concentrated in the central yellow spot known as the macula. In the center of that region is the "fovea centralis", a 0.3 mm diameter rod-free area with very thin, densely packed cones, we have the highest spatial

resolution (i.e. highest visual acuity, VA). Rods are present in the retinal periphery which has a very good ability to adapt to reduced brightness. The retina (i.e. the rods and cones) transforms light stimuli via chemical reactions into nerve impulses which are transmitted through the optic nerve to the visual cortex. These three layers/coats; sclera, choroid and retina, form a solid wall of the eyeball. Within these coats are the aqueous humour, the vitreous body, and the flexible lens. The aqueous humour is a clear fluid that is contained in two areas: the anterior chamber between the cornea and the iris, and the posterior chamber between the iris and the lens. The iris controls the diameter and size of the pupil (i.e. the eye's aperture) and thus the quantity of light reaching the retina. The lens is suspended to the ciliary body by the suspensory ligament (Zonule of Zinn), made up of fine transparent fibers. Contraction of the ciliary body changes the tension on the Zonula of Zinn which causes the lens to change shape so that the eye is able to change focus (i.e. accommodation). The lens is biconvex and can change its shape by a sphincter contraction that makes the lens steeper. The vitreous body is a clear jelly that is much larger than the aqueous humour present behind the lens, and the rest is bordered by the sclera, zonule, and lens. The human eye is shown in figure 2.

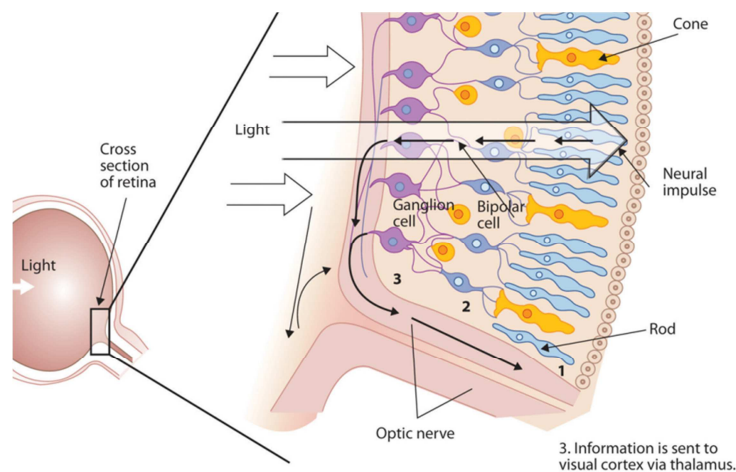

Figure 1. Illustration of the retina of the eye. (Picture from <http://images.flatworldknowledge.com/> printed with permission).

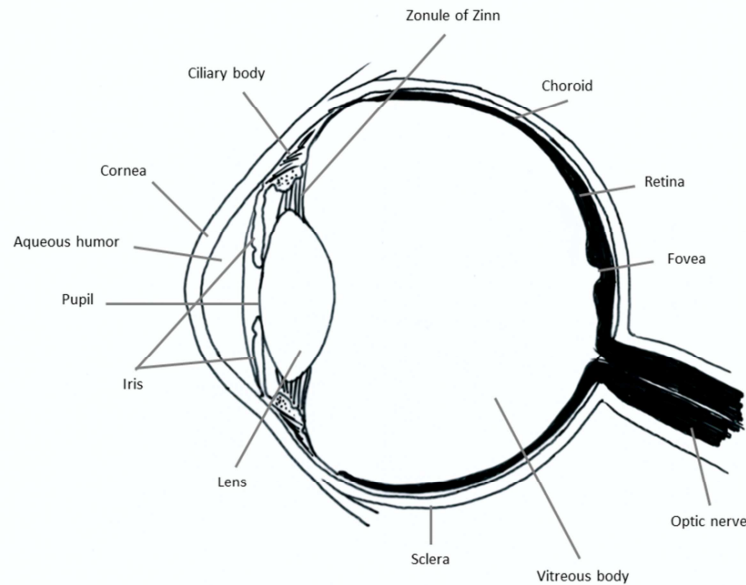

Figure 2. Illustration of the structure of the eye. Illustration: S. Glimne. The figure is based on the original by <http://se.vectorhq.com>

2.1.2 Visual ability and target visibility

The visual system includes the eyes, connecting pathways through the brain to the visual cortex, and associated areas of the brain (figure 3). The neural signals initially processed by the retina travel via the axons of the ganglion cells through the optic nerves, dividing and partially crossing over into the optic chiasm and then travel via the optic tracts to the lateral geniculate nucleus (LGN). From the LGN, the signals continue to the primary visual cortex, where further visual processing takes place. In a simplified manner the scotopic system (i.e. vision under low light conditions) enables an excellent spatial summation with an outcome of high sensitivity but poor spatial resolution. Scotopic vision is enabled exclusively through rod cells which are most sensitive to wavelengths of light around 498 nm (green-blue) and are insensitive to wavelengths longer than about 640 nm (red). The photopic system (i.e. vision under light conditions between 10 to 10^8 candela per square meter (cd/m^2)) enables less spatial summation contributing to poor sensitivity but an excellent spatial resolution (Schwartz, 2010). Photopic vision is enabled by the three types of cone cell which have maximum absorption values at wavelengths of about 420 nm (blue, mediated by the “blue cones”), 534 nm (bluish-green, mediated by the “green cones”), resp. 564 nm (yellowish-green, mediated by the “red cones”). However, their sensitivity ranges overlap to provide vision throughout the visible spectrum. The maximum efficacy is at a wavelength of 555 nm (green). As a consequence of this dual system we can see a dim star at night and yet have a scotopic VA of 0.1 (Schwartz, 2010) in contrast to the photopic visual system which reaches VA between 1.0 to 2.0 and even higher.

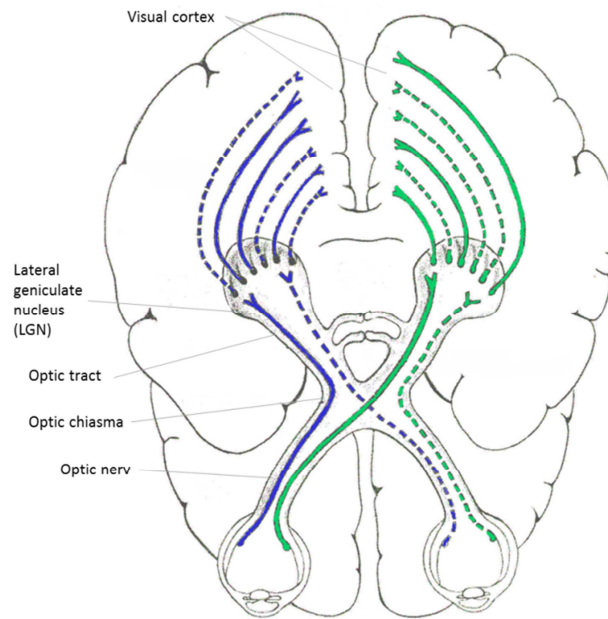

Figure 3. Illustration of the pathways from the retina to the visual cortex. Illustration: S. Glimne. The figure is based on the original by <http://www.skidmore.edu/~hfoley/images/>.

Contrast sensitivity of the eye can be defined as a contrast threshold which denotes the smallest amount of contrast required to be able to see a target. When an increased contrast threshold is required to see a target, conditions of decreased contrast sensitivity are present and vice versa (Benjamin, 2006). Contrast threshold varies with the brightness of the background. Accordingly, VA is influenced by luminance and contrast affects the visibility of the task. The following formula may be used to describe the contrast commonly applicable in the context of lighting and conditions where small features are present on a large uniform background (Pelli & Bex, 2013):

$$\text{Weber contrast} = \frac{\text{maximum luminance} - \text{minimum luminance}}{\text{background luminance}}$$

Light and dark adaptation denotes the eye’s ability to adapt to changes in illumination levels through interactions between a photochemical process in the retina, adaptive process in the nervous system and by adaptation of the pupil diameter. A stronger pupillary constriction generates a reduced exposure of the retina decreasing the risk of glare. Glare is defined by the Illuminating Engineering Society of North America (IESNA) as “the sensation produced by luminances within the visual field that are sufficiently greater than the luminance to which the eyes are adapted, which causes annoyance, discomfort, or loss in visual performance and visibility” (Lighting Research Center, 2015). Generally, glare can be categorized as disability glare (physiological) and discomfort glare (psychological). Disability glare refers to a reduction in visibility caused by intense light sources in the field of view and discomfort glare refers to sensation of annoyance or even pain induced by extremely bright light sources (Rea, 2000). Further, disability glare is caused by light scattering within the eye, causing a haze of veiling luminance, i.e. a luminance superimposed on the retinal image which decreases contrast and reduces visibility. Where lighting design for work environments is concerned discomfort glare is

a well-documented phenomenon (Garzia, 1996). A synergy between light, contrast and glare is needed to maximize visual performance (Pitts & Kleinstein, 1993).

2.1.3 Photometry - The measurement of light

Light distribution in space is very important for vision and the overall impression of the visual space. If luminance is inappropriately distributed and causes visual deterioration, unpleasantness can be experienced due to excessive luminance in the visual field.

Photometry is the science of the measurement of light in terms of its perceived brightness to the human eye. In photometry, the radiant power at each wavelength is weighted by a luminosity function that models human brightness sensitivity. Photopic vision is characteristic of the eye’s response at luminance levels over 3 cd/m². Scotopic vision occurs below 2×10⁻⁵ cd/m². Mesopic vision occurs between these limits and is not well characterized for spectral response (Bass, 1995).

Many different units are used for photometric measurements (e.g. lumens and candelas). The adjective “bright” can refer to a light source which delivers a high luminous flux (measured in lumens), or to a light source which concentrates its luminous flux into a very narrow beam (candelas), or to a light source that is seen against a dark background. Because of the ways in which light is transmitted through three-dimensional space — spreading out, becoming concentrated, reflecting from shiny or matte surfaces — and because light consists of many different wavelengths, the number of fundamentally different kinds of light measurement that can be made is large, and so are the numbers of quantities and units that represent them. Offices are typically “brightly” illuminated by an array of many recessed fluorescent lights for a combined high luminous flux. A laser pointer has very low luminous flux (it could not illuminate a room) but is blindingly bright in one direction (high luminous intensity in that direction).

Lighting *E* is the luminous flux/unit area that hits an illuminated surface (figure 4) and is measured in [lux] = [lumen (lm)/m²].

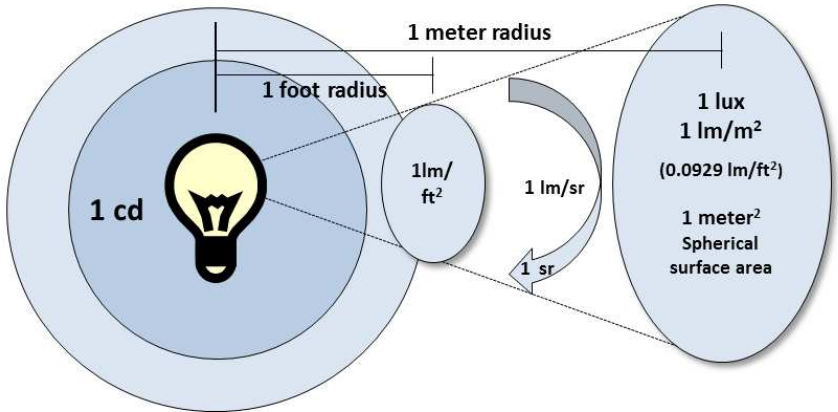

Figure 4. Illustration of luminous flux. If 1 lumen (lm) falls on a 1 m² surface area then the illuminance *E* is 1 lumen/m², or 1 lux. Illustration: S. Glimne. The figure is based on the original by Tunnacliffe (1997).

In most cases light is emitted or reflected from surfaces. When light is reflected from surfaces there is a luminous intensity I in each direction from which it is viewed (figure 5).

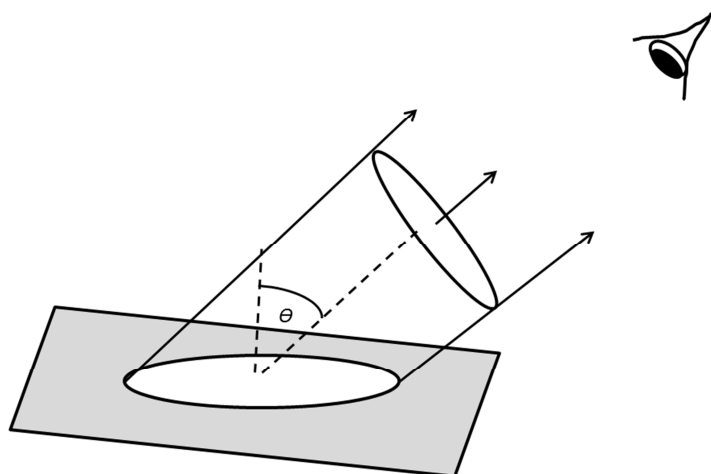

Figure 5. Illustration of luminous intensity I (Luminance L) towards a direction from which it is viewed. Illustration: S. Glimne. The figure is based on the original by Tunnacliffe (1997).

Luminance $L = I/(A \cos \Theta)$ cd/m^2 is measured in cd/m^2 and is dependent on surface reflection properties (gloss unit 0-100) and may be calculated according to the formula;

$$\text{Luminance } L = \text{reflectance} \times \text{illuminance } I$$

There are recommendations for illuminance in working environments. Visual requirements and visual stress are likely to increase under conditions that do not follow these recommendations. A uniformity of illuminance with a minimum of 0.5 (i.e. the ratio between minimum illuminance and average illuminance of a surface) is recommended (SS-EN 12464-1, 2011) for office work. Lighting is essential in visual demanding activities. If lighting is not optimal it will commonly attribute to visual disturbance. Glare, i.e. difficulty in seeing in the presence of bright light which enters they eyes either directly (direct glare) or through reflection (indirect glare) is a major source of visual discomfort when working with computer screens. When designing work stations luminaires should be placed so that direct or indirect glare does not exist in relation to the user's gaze angles. There is, however, general awareness that open-plan offices increases the risk of glare even though nearby luminaires are placed sited correctly since those located further away in the room will still be within a user's field of view either directly or through reflection from other computer screens or glossy surfaces. Environmental factors such as poor lighting design in a computer work-place contribute to reduced visual ability. Reduced visual ability may be the cause of asthenopia experienced while working with computers, but reduced visual ability may also contribute to an increase in static muscle activity in the neck- and shoulder region (Richter et al., 2012). Furthermore, even lower degree of blurring, caused for example by refractive correction not being adequately adjusted for the working distance, may lead to deterioration of work performance (Hemphälä & Eklund, 2012) and therefore be a source of discomfort during computer work.

2.2 THEORETICAL FRAMEWORK

The research work in this thesis includes three areas of clinical study which evaluate the effect of disability glare on binocular vision and reading behaviour while performing computer work. This section is intended to explain the theoretical background of this thesis.

2.2.1 Accommodation and vergence mechanism

The process of accommodation involves coordinated contraction and relaxation of the six extra ocular muscles in the two eyes in order to adjust eye position and adjustment of the ciliary muscle to change the refractive power. For prolonged close work the level of innervation to obtain single and clear vision has to be maintained.

When binocular fixation of an object is required at varying object distances, three distinct oculomotor activities occur which are intrinsically linked. If the object of interest moves closer to a subject, accommodation increases, the eyes converge (by equal amounts if the object is equidistant from both eyes) and the pupils constrict. If the object moves away, the opposite occurs.

The synkinesis of the three systems controlling accommodation, convergence or divergence and pupil size to produce a focused image of the object of interest on the fovea has been termed the “near triad” (Burian & von Noorden, 1974; Fincham, 1951). The effect of pupil size in relation to accommodation and vergence is outside the scope of this thesis.

Accommodation is the adjustment of the power of the eye. This takes place so that objects of interest at any distance from the eye can be focused on the retina. Accommodation has been described, analogous to the components of vergence discussed below, as having the following features (Heath, 1956): (1) Reflex accommodation, the part of accommodation response, which occurs solely in response to changes in the vergence of incident light. (2) Tonic accommodation, the resting state of accommodation that is assumed when the eye has no stimulus, e.g. in complete darkness or in a uniformly bright field of view. This resting state is determined by the balance of sympathetic and parasympathetic innervations (Gilmartin et al., 2002; Winn et al., 2002; Culhane & Gilmartin, 1999). (3) Proximal accommodation, the accommodation response stimulated by the awareness of an object being near. (4) Convergence accommodation (CA), the accommodation response that occurs due to changes in convergence. If a vergence eye movement is prompted while viewing a stimulus in which all visual stimuli for accommodation have been removed, the eyes will show a change in the level of accommodation. The visual stimuli for accommodation can be removed most easily by viewing the target through a pinhole to ensure a large depth of field. Preventing the change in accommodation affecting the clarity of the retinal image in this way is referred to as “open-looping” the accommodative system.

A noteworthy feature of the accommodation system is the ability to adapt to changing conditions. Following prolonged accommodative effort, for example viewing a near target, the eyes return much more slowly than normal to their tonic position when the stimulus is removed

(see for example Rosenfield & Gilmartin, 1989; Miles, 1985). This effect is known as accommodative adaptation.

Vergence eye movements (the common term for either convergence or divergence) are prerequisites of normal binocular vision. Vergence movements minimize retinal disparity and place the two retinal images of a single object on corresponding retinal points. Analogous to accommodation, vergence movements have been identified as containing the following four features (Maddox, 1886): (1) Fusional vergence, the part of the vergence movement necessary to achieve sensory fusion and avoid diplopia and which occurs in response to retinal disparity. Retinal disparity provides information about both direction and magnitude for the fusional vergence movement needed. (2) Tonic vergence, a continuous effort of convergence, which maintains the eyes in their physiological position of rest. (3) Proximal vergence, the part of the vergence movement initiated by an awareness of a near object. (4) Accommodative vergence (accommodative convergence, AC), the part of the vergence reflex that occurs solely due to changes in accommodation. If one eye is occluded so that there is no stimulus for vergence movements and the other eye is presented with an accommodative stimulus, then the occluded eye will make a vergence movement. The process of removing vergence stimuli is referred to as making the vergence system “open-loop”.

In a similar manner to the accommodation system, the vergence system exhibits adaptation (Schor, 1986; Miles, 1985; Henson & North, 1980),

Binocular disparity within Panum’s fusional area is the slightly different view of an object due to the horizontal separation of the two eyes. When fixating a 3D object without any retinal disparity (i.e. the two visual lines from the foveas, which are corresponding points, meet exactly on the same part of the object) all other parts of the object will not project to corresponding retinal locations. Due to neural coding of binocular disparity in the two eyes’ 2D images we are able to perceive the world in 3D (Qian, 1997). Cumming & Parker (1997) and Howard & Rogers (1995) have further shown that binocular disparity within Panum’s fusional area is a signal not only to compute stereoscopic depth, but also provides information to the vergence system for fine eye alignment. This interaction of binocular disparity visual input and the vergence system takes place in order to help the vergence system not only reduce retinal disparity, i.e. reduce fixation disparity within Panum’s fusional area to a minimum, but also to bring both eyes in register in order to optimize stereoscopic perception (see next section for further description of fixation disparity). In computer work the central visual field, i.e. the visual field subtended by the computer screen, will only contain 2D stimulation and hence the visual system lacks one source of information for the fine vergence control needed to avoid seeing double (diplopia). This will increase the load on the vergence system and may induce symptoms.

2.2.2 Fixation disparity (FD)

Fixation disparity (FD) is the condition in which the images of a binocularly fixated object are not imaged on exactly corresponding retinal points but are still within Panum’s fusional area (figure 6). Therefore, a FD may be present when a subject has binocular single vision. When

measuring subjective FD with nonius lines it is assumed that the positions of the lines accurately reflect eye position. The accuracy of the ocular muscular system can therefore be assessed using this measurement (Jainta & Jaschinski, 2002). In optimal and precise binocular vision images in the two eyes of the fixated target are projected centrally in the fovea and the visual axes of both eyes intersect at the fixation point, see figure 6 and 7. FD is typically determined using dichoptic nonius lines adjusted for alignment. When a vergence error is present a deviation of the positions of the nonius lines is concurrently present (figure 6 and 7).

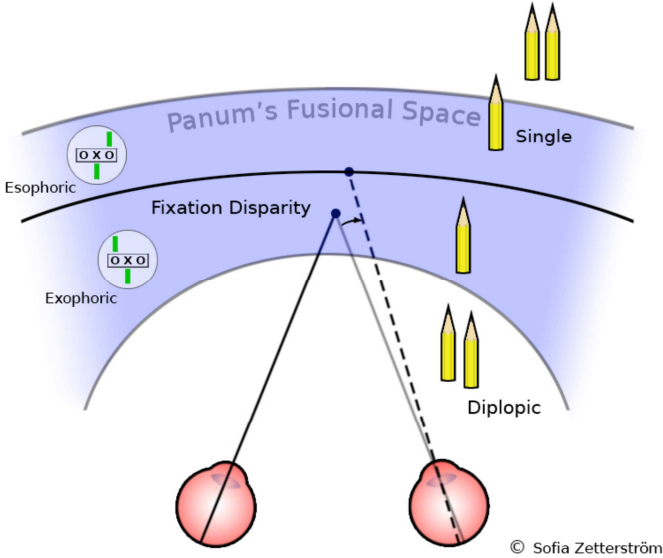

Figure 6. Illustration of Panum’s fusional space (area). Illustration: S. Zetterström (printed with permission).

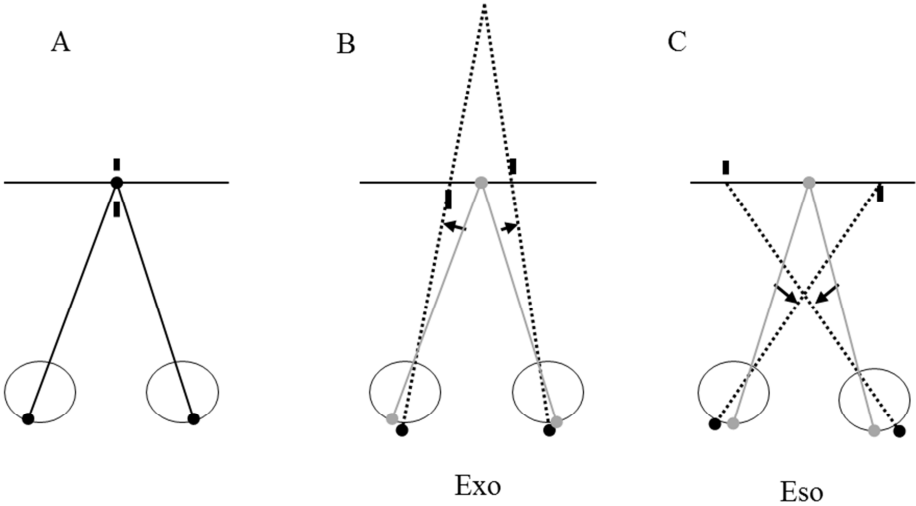

Figure 7. Illustration of the retinal projection of the nonius lines in each eye and required physical position for perceived alignment. Figure A represents accurate vergence; B Exo deviation; and C Eso deviation. Illustration: S. Glimne. The figure is based on the original by Jainta & Jaschinski (2002).

Small errors in vergence (a few minutes of arc), i.e. slight deviations within Panum’s fusional area, are to be expected (Howard & Rogers, 1995). Panum’s area is the region of sensory

fusion where small vergence deviations do not lead to the perception of double vision. Measurement of FD larger than a few minutes of arc is considered to be an indicator of oculomotor stress (Pickwell, 1997; Jaschinski-Kruza, 1993; Pickwell et al., 1987; Yekta et al., 1987) that provides information about the quality of the disparity vergence system. As far as the visual system and binocular control is concerned, Jainta et al. (2011), Jaschinski-Kruza (1994) and Pickwell et al. (1987) identified degraded stimuli contrast as reducing the capacity for binocular coordination, i.e. blur had a strong effect on fixation disparity. In relation to visually demanding tasks the presence of FD has been shown to be associated with visual symptoms and complaints (Jaschinski-Kruza, 1993).

2.2.3 Reading behaviour

While reading the eyes make short and rapid movements (saccades) that generally move the eyes forward approximately 6-9 character spaces, although with a considerable variation. The duration of saccades (20-50 milliseconds) depends upon the length of the movement. Fixations are between the saccades where the eye remains stationary with duration of approximately 200-250 milliseconds (Rayner, 1998, 1978). When moving to the next line return sweeps are performed that are of similar duration as saccadic eye movements. Illustrations of eye movements when reading can be seen in figure 8. To refixate words regression eye movement (10-15% of the saccades) are performed directed from right to left. Regressions have a tendency to be only a few letters long and may be due to over-long saccades. Regression may be necessary for efficient perception but those that are more than 10 letter spaces result from text confusion or comprehension problems (Rayner, 1998).

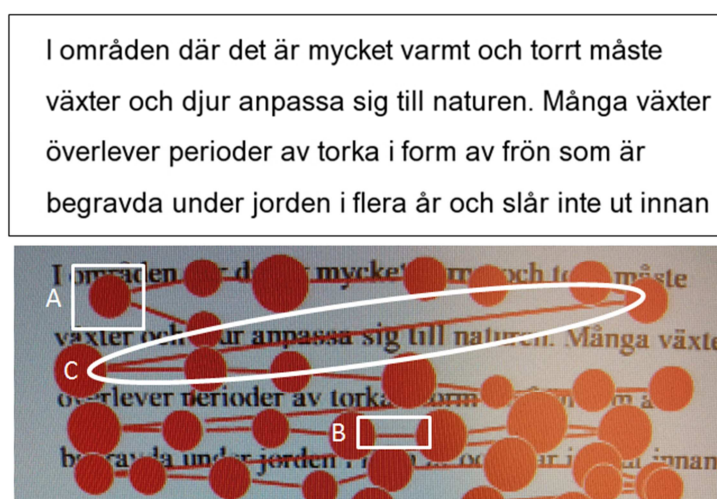

Figure 8. Illustration of eye movements when reading. The upper text illustrates part of an original IReST-text. The lower text illustrates an overlay of eye movements when reading the text showed above. The reader is moving forward in the text reading from left to right. Figure A represents fixation (the eye remains stationary with duration); B saccade (move the eyes forward); and C return sweep (moving to the next line). Illustration: S. Glimne.

The considerable variation in saccade length and fixation duration is related to ease or difficulty involved in processing the target text (Rayner, 1998). Reading speed and reading

performance has been widely studied and it has been concluded that only a few letters are recognized on each fixation. Legge et al. (2001) suggested that reading speed is limited by the number of letters recognized in parallel, i.e. visual span (for reference, see O'Regan, 1991, 1990). Visual span is defined as the area around the fixation point within which characters of a given size can be detected (O'Regan, 1991, 1990). A reduced contrast in the retinal image or reduced contrast sensitivity decreases the visual span. Accordingly, Legge et al. (2001) have viewed the reader as recognizing fewer letters per fixation and as a consequence saccades involve smaller steps with a corresponding decline in reading speed.

A report by Jainta et al. (2011) has showed that text comprehension did not change, even though moderate text degradation increased fixation times when reading. Further, they found that saccade amplitude decreased and the fixation duration increased blurring the visual task. The result suggested that reading comprehension was robust in withstanding changes in binocular coordination. They concluded that these changes were likely to be linked to the development of visual fatigue and eye strain. Their observations indicated impact of blur on the disparity-driven fine-tuning of the vergence adjustments due to the impairment of the blurred image in terms of high spatial frequencies. Moreover, due to a decrease of luminance contrast between digital characters and background on computer screens fixation rates and fixation duration increased (Ojanpää & Näsänen, 2003; Legge et al., 1997). Ojanpää & Näsänen (2003) suggested that reduction of reading speed (words per minute, WPM) was a result of increased fixation rates and fixation duration. Furthermore, a study (Johansson et al., 2014) has examined the extent to which binocularity contributes to reading performance as stimuli contrast decreases compared to monocular reading. Their results showed that binocularity provided an advantage with reduced stimuli contrast, due to the processes affecting fixation duration.

Computational models allow recording eye movements in order to support, explain, and guide empirical research on reading behaviours (Nuthmann, 2014; Rayner, 1998). These computerized models can enable researchers to inspect and manipulate various assumptions about cognitive processes to verify that interactions between these elements influence the simulated reading behaviours. Measured reading performance is valuable in predicting visual ability and may therefore be useful in the assessment of visual impairment (McClure et al., 2000). Measuring reading performance provides the text presentation format that best support reading (Öquist, 2006). Further, Öquist (2006) concluded that tracking and analysis of eye movements becomes interesting as the reading process can proceed and “be used as an additional measure of how the reading process has proceeded”. To evaluate digital reading, i.e. computer work, in terms of different glare conditions reading behaviour can be assessed to provide information on the efficiency of reading performance. Standardized texts can be used for repeated measurements to assess reading performance. Paragraphs are preferable to single sentences for accurate measurement (Trauzettel-Klosinski et al., 2012). When determining reading behaviour it is necessary to use highly comparable sentences (test task) in order to minimize variation in reading performance due to differences in the test sentences (Radner et al., 2002).

3 MATERIAL AND METHODS

This section contains detailed descriptions of the procedures that were followed in completing the four included studies in this thesis. Material and methods are presented from study design.

3.1 MATERIAL/DATA COLLECTION

In Paper I twenty-three subjects (21 women and 2 men, age 30.0 years \pm 7.36) were recruited from a list at the University Open Clinic, Karolinska Institutet, of university students who had agreed to be contacted for future research studies. Inclusion criteria for the trial were limited near point of convergence (NPC) between 5 and 15 cm and a fusional vergence which was twice the near phoria. Participants were excluded if they reported subjective symptoms that could be related to accommodation and vergence disorders, i.e. visual and ocular discomfort when performing near visual tasks.

Participants in Paper II-IV were students, randomly approached on the university campus at Karolinska Institutet and invited to participate. Subjects with refractive errors and heterophoria were included as long as the heterophoria did not give rise to any symptoms. The order of test conditions was determined for each volunteer by Graeco-Latin Square design to avoid test order effects (Euler square: Euler, 1782, cited in Kotz, 2006), and in total sixteen subjects were included in each paper; Paper II: 16 women (age 25.5 years \pm 3.56); Paper III: 14 women and 2 men (age 24.4 years \pm 2.4); Paper IV: 15 women and 1 man (age 30.5 years \pm 7.04) respectively. The design involves two sets of $n \times n$ elements; lower-case and capital letters in each box, so that all n^2 possible pairs appear in the array, and such that in each row (4), and in each column (4), all the n^2 elements are different, see table 1. Accordingly, settings of lighting conditions (A-D) and reading tasks (a-d) are randomized orthogonally for each order. To carry out an experiment with this type of design a population of sixteen subjects will be needed, one for each series (1-16):

Table 1. Graeco-Latin Square Design.

1. Aa Bc Cd Db	5. Bb Ad Dc Ca	9. Cc Da Ab Bd	13. Dd Cb Ba Ac
2. Bc Db Aa Cd	6. Ad Ca Bb Dc	10. Da Bd Cc Ab	14. Cb Ac Dd Ba
3. Cd Aa Db Bc	7. Dc Bb Ca Ad	11. Ab Cc Bd Da	15. Ba Dd Ac Cb
4. Db Cd Bc Aa	8. Ca Dc Ad Bd	12. Bd Ab Da Cc	16. Ac Ba Cb Dd

When evaluating reading behaviour the factor of presentation order has to be taken into account. Öquist (2006) adopted randomization of presented texts by transposition creating three additional fourth order squares, i.e. table of sixteen rows and four columns (for detailed information and illustration, see Öquist, 2006). With the Graeco-Latin Square design, reading tasks used and the lighting designs were balanced to enable evaluation of the lighting designs presented. The design included a within-subject repeated-measurement experimental design limiting the effects of variance on the results caused by the subjects' performance. The study

design adopted took the fatigue that arises during the final sessions of such prolonged visually demanding near work into account.

Inclusion criteria for all trials included asymptomatic, free of ocular pathology and strabismus, no history of ocular treatment, no medication with known effect on VA and/or binocular vision, BCVA (best corrected visual acuity) of at least 1.0 both monocularly and binocularly, and stereo acuity with the TNO (random-dot) stereo test of 60 sec or better. The age inclusion criterion was set to 45 to avoid unreliable measurements due to human presbyopia (Benjamin, 2006).

3.2 METHODS

To evaluate the capacity of the vergence control mechanism in the first study centrally placed 3D features were introduced and compared to a target containing only 2D features. Three repeated measurements of near point of convergence (NPC) were performed using a modified RAF-ruler with 3D- and 2D stimuli. The 2D object was a colour printed image of the 3D object (figure 9). Participants fixated the same star during the test procedure with instructions to keep the star single for as long as possible and to report as soon as they perceived the star as double, i.e. break point of NPC. Initially the target was placed 50 cm from the subject's eyes. An apparent increase in the size of the cube was perceived by the subject due to decreased distance when the object was moved closer to the eyes (table 2). The distance at which the subject reported double vision of the star was noted. The order of the 3D and 2D NPC measurements was randomized but not counterbalanced, i.e. testing started with 2D and 3D alternately when changing test subject.

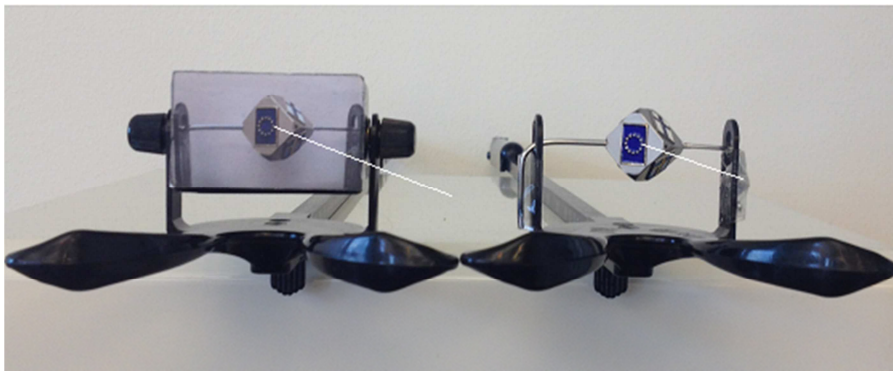

Figure 9. Illustration of the stimulus for the 3D condition (1.5 × 1.5 cm), a metal cube with coloured flags elevated 0.5 mm from the surface, and the stimulus for the 2D condition.

Table 2. Field size, in degrees, of the visual field covered by the cube at different distances.

Distance (cm)	10	20	30	40	50
Field size (degrees)	8.53 × 8.53	4.30 × 4.30	2.86 × 2.86	2.15 × 2.15	1.72 × 1.72

In Paper II-IV studies were designed as balanced repeated measurements experiments introducing four lighting conditions (Graeco Latin Square) to avoid test order errors. The luminance levels were measured where the eyes were placed during the task and test periods. The measurements of luminance were carried out using a Hagner luminance meter (Model S2), Hagner AB, Sweden. It is a convenient study design that takes into account light-adaptation (i.e. the ability of the visual system to adjust to various levels of light). Induced glare produced by a light source endures for a period of time normally up to 50 seconds (Benjamin, 2006) according to photo stress recovery time, i.e. the period between when the light is removed and the subject is able to read on the visual acuity chart just above the initial VA. Based on recommendations (ISO 9241-302:2008 standard; U.S. Department of Labor, 1995) the topmost line of the computer screen (17") was placed at or slightly below the subject's eye level, i.e. with the centre of the computer screen approximately 19-22° below horizontal eye level.

Paper II and IV included repeated measurements of horizontal FD performed on a 17" LCD computer screen (Eizo FlexScan™ S1721) customized in an in-house display program written in Matlab (Nilsson et al., 2011, 2008) with the Psychophysics toolbox (Brainard, 1997; Pelli, 1997), for illustration, see figure 10. The setup used red/green separated nonius lines as a dichoptic vernier alignment task similar to a Sheedy disparometer or the instrumentation used for FD measurements by Ogle & Prangen (1953, 1951), and the computerized method used by Jaschinski (1998). The nonius lines were monocularly separated when wearing red/green filters. The lines subtended approximately 15 min of arc vertically, 1.5 min of arc horizontally and were separated by 2 min of arc using a horizontal black line. A text in a font with a height of 2 mm (black on white background) covered the whole computer screen. The text and the black line were both seen binocularly to help maintaining stable and horizontal vertical vergence from central and peripheral fusion. The system enables settings of fixation disparity with increment steps of 0.05 min of arc through sub-pixel calculation of the Gaussian luminance profile of the nonius lines. Accordingly, step size was 20 times more sensitive than normal, so that subjects had precise control over the nonius position (Nilsson et al., 2008). The participant's task during measurements was to set the nonius lines to what they considered the perfect horizontal alignment by moving the green nonius line which was seen by the left eye (by sliding a computer mouse forwards and backwards (Paper II) or clicking on a keyboard (Paper IV)). The program automatically recorded the nonius line settings each time the space bar was clicked to signify that alignment had been attained and randomly displaced the green nonius line after each setting to provide repeated measurements. During all testing periods the positions of the subjects' heads were restrained with the help of a chin and forehead rest at a distance of 60 cm from the screen.

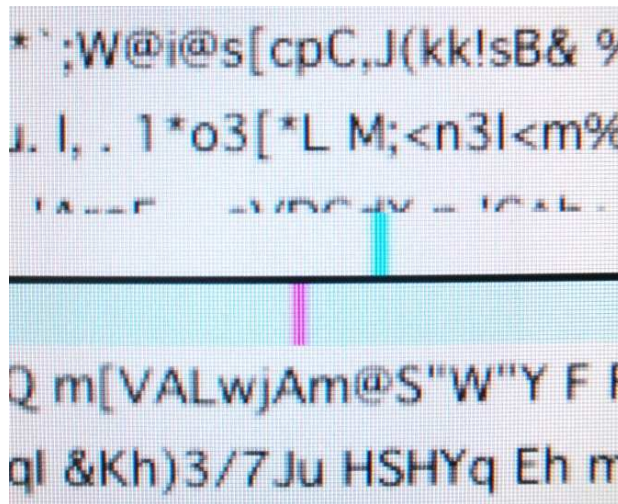

Figure 10¹. Illustration of the red and the green nonius lines placed in the middle of the computer screen. Test used in study II and IV.

To investigate the impact of different glare conditions as induced stress on binocular vision while performing computer work repeated FD measurements were used as a measure of vergence control. During the test procedure for all four lighting conditions in Paper II, all volunteers viewed an LCD-screen uninterruptedly except for periods of 40 seconds (range 30-50 seconds) when the lighting conditions were changed. Each session with a different lighting condition lasted until the volunteer had finished the task and the fixation disparity measurements were completed. The computer tasks included locating ten cities on a map and then a reading task (LIX 39-43; Björnsson, 1968, figure 12). The task in each of the lighting condition took about 15 minutes including the FD measurement of approximately 1-2 minutes. In addition to a non-glare condition (ceiling luminary, placed above, 800 cd/m²), three controlled glare conditions were used: (1) direct light from a ceiling luminary in front facing 80° toward subject (6100 cd/m²); (2) indirect light from an artificial window behind the screen (1850 cd/ m²); and (3) a desk luminary to the right (450 cd/ m²). The surrounding area had a luminance level of 200 cd/m². To avoid uncontrolled surface reflections the table had a non-glossy black surface with a light mouse pad placed in front of the eyes. For illustration, see figure 11.

¹ Reprinted from Publication Work, 45, S. Glimne, G Öqvist Seimyr, J Ygge, P Nylén and RL Brautaset, Measuring glare induced visual fatigue by fixation disparity variation, p 433., Copyright (2013), with permission from IOS Press.



Figure 11². Illustration of the computerized FD test and lighting conditions used in study II.

In Paper III, the participants' eye movements were recorded using a Tobii T120 Eye Tracker to investigate the effect of glare conditions while performing computer work. Eye movement recordings were analysed in two steps: (1) fixations were detected; (2) categorized movements between the fixations were detected. Fixations were defined as periods when the eye was within 1.5 degrees from a cumulative midpoint for at least 100 milliseconds (i.e. gaze kept stabilized in the fovea). Movements between fixations were categorized by length and direction. Movements of less than 6.3 degrees (movements within parafovea) were classified as saccades if the movements went in the reading direction (forward/down), otherwise as regressions. Movements longer than 6.3 degrees were categorized as forward sweep, reverse sweep, sweep upward or downward sweep.

Subjects read two short readability controlled text, i.e. IReST, 146 words (Trauzettel-Klosinski et al., 2012) before and after a longer newspaper text (~800 words, LIX 39-43; Björnsson, 1968). The near task was performed on a 17" TFT computer screen at a distance of 65 cm. All in all the trial included eight short and four longer texts. For illustration, see figure 12. Reading speed, fixation rates, fixation duration, saccade rates and regression rates were analysed. The recorded data were processed using Visiolyzer software. Repeated measurements of eye movements were recorded in four controlled lighting conditions: (1) no glare (ceiling luminary, placed above, 800 cd/m²); (2) direct light from a ceiling luminary in front (1250 cd/m²); (3) indirect light from an artificial window behind the screen (1850 cd/m²); and (4) a desk luminary to the right (450 cd/m²). The surrounding area had a luminance level of 200 cd/m². The subjects were instructed to read silently and questions were asked after every trial to ensure that they read for comprehension. During the test procedure of all four lighting conditions, all subjects were

² Reprinted from Publication Work, 45, S. Glimne, G Öqvist Seimyr, J Ygge, P Nylén and RL Brautaset, Measuring glare induced visual fatigue by fixation disparity variation, p 433., Copyright (2013), with permission from IOS Press.

looking at the Tobii screen. There were short interruptions of approximately 130 seconds when lighting conditions were changed and subjects answered comprehension questions. Each session with different lighting condition lasted until the subject had finished the tasks which usually took about 7-10 minutes (in total 32 ± 5). As in Paper II, the table had a non-glossy black surface to avoid uncontrolled reflection with a light mouse pad placed in front of the eyes. For illustration, see figure 13.

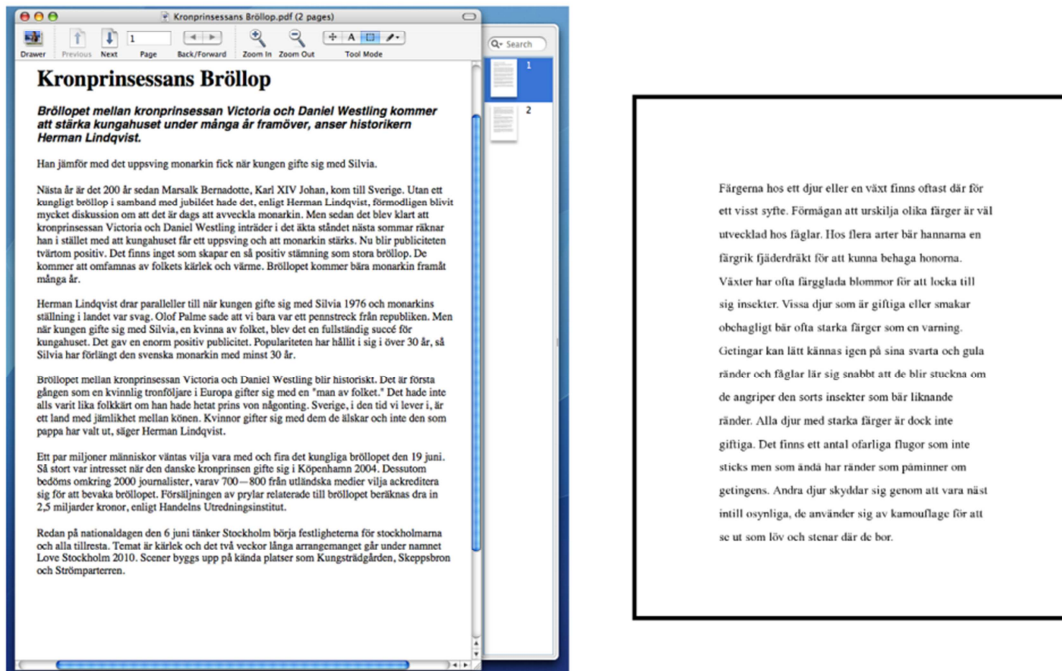

Figure 12. Illustration of examples of reading tasks used in study II-IV.



Figure 13³. Illustration of the Tobii Eye Tracker and lighting conditions used in study III.

In Paper IV repeated measurements of horizontal FD were obtained to evaluate the threshold luminance level of direct glare, i.e. to evaluate at what level vergence control starts being affected by glare. Four controlled lighting conditions of direct glare were used: (1) no glare (recessed ceiling luminary placed above with a luminance of 600 cd/m^2); (2) 2000 cd/m^2 ; (3) 4000 cd/m^2 , and (4) 6000 cd/m^2 . In all glare conditions a ceiling luminary in front was used at a distance of 100 cm. In order to induce direct glare the luminary was turned 80° toward the subjects' eyes with a vertical angle of 10° . The surrounding area had an average illuminance level of 450 lux (illuminance uniformity ratio: 0.4) and an average luminance level of 125 cd/m^2 . During the test procedure for all four lighting conditions, all subjects initially looked at a computer screen without interruption performing repeated FD measurement in terms of the lighting condition used. Secondly, subjects were asked to reposition themselves in front of an additional computer screen to undertake three tasks continuously: initially they read a standardized text, IReST (Trauzettel-Klosinski et al., 2012), then a longer newspaper text, and finally a second IReST text. The subjects then moved back to the screen to perform repeated FD tests to finish the session. In total eight short and four longer texts were used. The subjects were instructed to read silently for comprehension. At the end of each trial, subjects answered comprehension questions and finally survey questions on the impact of glare on computer work performance using a score between 0-4: (0) Never; (1) Seldom; (2) Sometimes; (3) Often; (4) Constantly, (tired eyes, headache, difficulties in remembering the text, double vision, blurred vision, needing to reread the text). The only interruption of the near visual tasks during the test

³ Reprinted from Publication Work, 50, S. Glimne, RL Brautaset and G Öqvist Seimyr, The effect of glare on eye movements when reading, p 215., Copyright (2015), with permission from IOS Press.

process for each lighting condition session comprised periods of nearly 5 seconds while subjects moved between the computer screens. The reading task was normally finished after approximately 10 minutes, the FD measurement took about 1-2 minutes, and answering the questionnaire including change of lighting condition took about 3 minutes (in total 68 ± 2). The table had a non-glossy black surface (gloss unit: 7) to avoid uncontrolled surface reflection. For illustration, see figure 14.



Figure 14. Illustration of the setup using a luminaire in front to induce direct glare when performing reading task in study IV.

3.3 STATISTICS

The Instat™ GraphPad Software Inc. version 3.00 (Paper I, III, IV) and OriginPro 8 (OriginLab Corporation) (Paper II) were used for calculations. For comparison between normally distributed data a paired two-tailed t-test (Paper I), one-way repeated-measures ANOVA with Tukey-Kramer Multiple Comparisons Test with Post-hoc Tukey tests (Paper II-IV) and Mauchly's Test of Sphericity (Paper II) were used. Additional comparisons in Paper II-IV were analysed using paired two-tailed t-test. Throughout the thesis the significance level was set at 0.05 and the confidence coefficient to 0.95.

3.4 ETHICS

Ethical approval (DNR 2008/552-31) was granted by the Regional Ethical Review Board in Stockholm and informed consent was obtained from all subjects before participation. The studies included adhered to the tenets of the Declaration of Helsinki.

4 RESULTS

4.1 PAPER I

Based on the average of the three repeated measurements of break point NPC in 23 subjects a significant difference ($p = 0.0172$) was found with the 3D condition giving the better result compared to the 2D condition. Comparison of the most remote recorded NPC values of the three repeated measurements under each stimulus condition revealed a significant difference with 3D stimuli giving the better result ($p = 0.0159$).

4.2 PAPER II

The results from the FD measurements were found to increase toward esophoric (crossed) vision with increased severity of glare condition. No differences were found between the lightning conditions when analysing the average (mean) of the first 15 FD measurements from the sixteens subjects included but a significant difference could be determined based on the standard deviations ($p < 0.001$), i.e. differences in variation. The variation (SD) among FD measurements evidently increases with increased degree of glare (figure 15). In the lighting condition of direct glare ($p = 0.002$) and the desk luminary condition ($p = 0.007$) there was a significant higher FD variation compared to no glare. The average amount and confidence interval of all FD measurements under the different lighting conditions can be seen in figure 16.

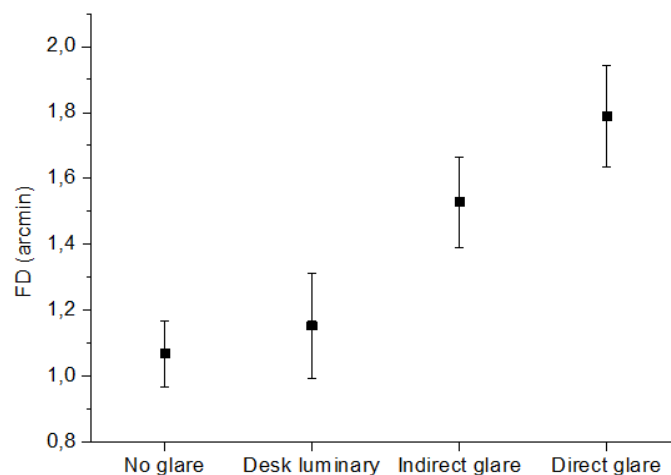

Figure 15⁴. Average FD variation (SD) between the conditions, whiskers indicates standard error.

⁴ Reprinted from Publication Work, 45, S. Glimne, G Öqvist Seimyr, J Ygge, P Nylén and RL Brautaset, Measuring glare induced visual fatigue by fixation disparity variation, p 435., Copyright (2013), with permission from IOS Press.

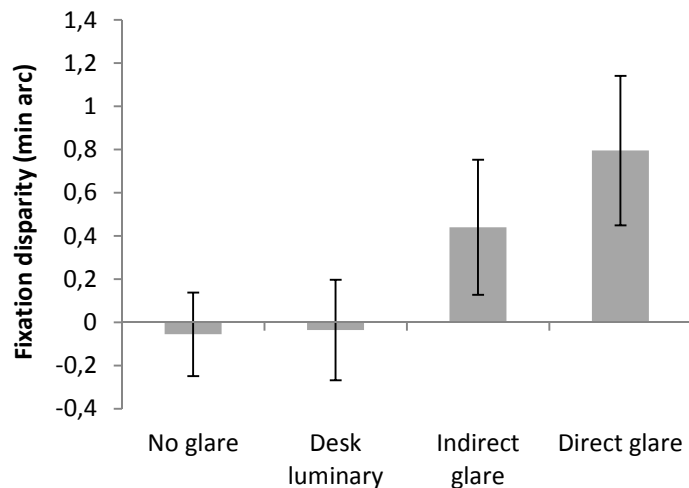

Figure 16. Average (mean) of the first 15 FD measurements between the conditions with 95% confidence interval. Negative values represent exophoric deviation whereas positive values represent esophoric deviation.

4.3 PAPER III

Statistical analysis of reading speed indicated no significant difference between lighting conditions regarding the short standardized texts (IReST). There were significant differences for the long texts independent of lighting condition so that no further analysis was undertaken with regard to the newspaper texts. Comparisons showed that all the newspaper texts except 2 and 4 differed significantly from each other ($t > 8.8$, $p < 0.001$).

Pairwise comparisons of the short pre- and post-readability controlled texts revealed a significant difference in increased reading speed ((WPM) between the texts in relation to the desk luminary lighting condition ($p < 0.05$) and close to significance in the no glare lighting condition. There was no significant difference between the texts in direct and indirect glare lighting conditions. In addition a significant difference was found in fixation rates per second with an increased rate for the second IReST texts in the desk luminary lighting condition ($p < 0.005$). The difference in fixation durations were significant concerning shorter durations for the second IReST texts in lighting conditions of no glare ($p < 0.01$), desk luminary and indirect glare ($p < 0.05$). The saccade rates per second differed significantly with an increased rate for the second IReST texts in the no glare ($p < 0.05$) and desk luminary ($p < 0.05$) lighting conditions. There were no significant differences in regression rates per second between pre and post IReST texts under the different lighting conditions.

Further analysis of the second IReST text revealed slower reading speed (WPM) in all glare conditions but the difference was not significant. Fixation rates per second decreased significantly in direct ($p < 0.01$) -and indirect ($p < 0.05$) glare conditions. Fixation duration was longer in all glare conditions and differed significantly in the direct glare lighting condition ($p < 0.01$). There were lower saccade rates per second in all glare conditions with a significant decrease for direct glare ($p < 0.05$) and indirect glare ($p < 0.05$). Regression rates

per second did not differ significantly under the four lighting conditions. An illustration of individual's recorded result can be seen in figure 17. The average results and standard deviation for all tests of measured reading eye movements, including reading speed (WPM), under the different lighting conditions can be seen in table 3 and 4.

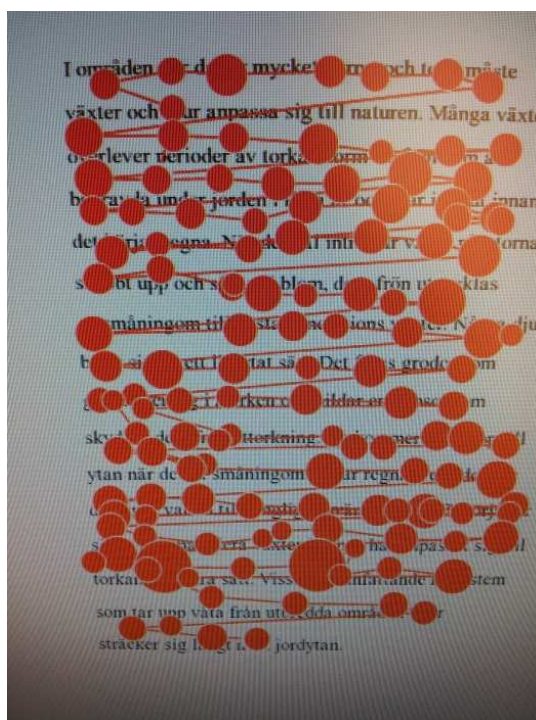

Figure 17⁵. Illustration of an individual result recorded by Tobii T120 Eye Tracker using an IReST text.

Table 3. Mean and standard deviation of reading eye movements of the first IReST texts.

Eye movements	No glare		Desk luminary		Indirect glare		Direct glare	
	Mean	SD	Mean	SD	Mean	SD	Mean	SD
Reading speed (WPM)	276.58	±77.37	251.01	±72.50	257.12	±74.27	263.67	±96.31
Fixation rates/sec	2.96	±0.43	2.85	±0.38	2.90	±0.41	2.85	±0.35
Fixation durations (msec)	299.09	±49.14	312.82	±56.26	307.24	±54.84	311.06	±48.36
Saccade rates/sec	2.17	±0.24	2.05	±0.22	2.11	±0.29	2.03	±0.25
Regression rates/sec	0.24	±0.14	0.25	±0.15	0.26	±0.12	0.27	±0.16

⁵ Reprinted from Publication Work, 50, S. Glimne, RL Brautaset and G Öqvist Seimyr, The effect of glare on eye movements when reading, p 218., Copyright (2015), with permission from IOS Press.

Table 4. Mean and standard deviation of reading eye movements of the second IReST texts.

Eye movements	No glare		Desk luminary		Indirect glare		Direct glare	
	Mean	SD	Mean	SD	Mean	SD	Mean	SD
Reading speed (WPM)	300.28	±97.82	286.84* ¹	±92.25	264.85	±86.67	263.29	±67.77
Fixation rates/sec	3.14	±0.43	3.03* ¹	±0.44	2.96* ²	±0.35	2.91* ²	±0.38
Fixation durations (msec)	280.22* ¹	±47.42	293.65* ¹	±46.78	291.38* ¹	±45.45	304.92* ²	±45.88
Saccade rates/sec	2.25* ¹	±0.23	2.16* ¹	±0.24	2.10* ²	±0.22	2.10* ²	±0.20
Regression rates/sec	0.28	±0.12	0.29	±0.19	0.31	±0.13	0.26	±0.19

*¹ Significant difference between pre and post texts.

*² Significant difference between lighting conditions.

4.4 PAPER IV

In accordance with Paper II the results from the FD measurements were found to increase toward esophoric (crossed) vision with increasing severity of glare. No differences were found between the lightning conditions when analysing the average (mean) of the first 15 FD measurements before and after a near visual reading task from the sixteens subjects included. However, a significant difference could be determined based on the standard deviations ($p = 0.0358$). Pairwise comparisons between initial measurements in the lighting condition of no glare and measurements performed after reading tasks in all glare conditions revealed a significantly higher variation in all three lighting conditions (2000 cd/m^2 , $p = 0.0451$; 4000 cd/m^2 , $p = 0.0425$; 6000 cd/m^2 , $p = 0.0297$). The average results and standard deviation for all FD measurements under the different lighting conditions can be seen in table 5.

Table 5. The average amount (mean) and standard deviation (SD) for all fixation disparity (FD) measurements under the different lighting conditions.

	No glare		2000 cd/m^2		4000 cd/m^2		6000 cd/m^2	
	First	Second	First	Second	First	Second	First	Second
Mean	-0.69	-0.68	-0.66	-0.89	-0.51	-0.58	-0.43	-0.25
SD	±1.55	±1.87	±2.00	±2.30*	±1.67	±2.08*	±1.31	±1.78*

* Significant difference between initial measurements in the lighting condition of no glare and measurements performed after reading tasks.

No significant difference was found between lighting conditions in the responses to the subjective assessment of the impact of glare on computer work performance. However, the

subjective response regarding pain in the eyes was considered close to significance ($p = 0.0907$). Furthermore, pairwise comparisons of 2000 cd/m^2 and 6000 cd/m^2 lighting conditions displayed a significant difference ($p = 0.0317$). The average responses and standard deviation for the subjective grading of the impact of glare on computer work performance under the different lighting conditions can be seen in table 6.

Table 6. The average responses (mean) and standard deviation (SD) for subjective grading of the impact of glare on computer work performance under the different lighting conditions.

	No glare		2000 cd/m ²		4000 cd/m ²		6000 cd/m ²	
	Mean	SD	Mean	SD	Mean	SD	Mean	SD
Tired eyes (Fatigue)	1.75	±1.24	1.81	±1.11	2.00	±1.21	2.25	±1.18
Headache	0.94	±2.74	0.25	±0.45	0.50	±1.15	0.44	±1.09
Difficulties in remembering the text	1.37	±0.81	1.75	±1.06	1.94	±1.06	1.87	±1.20
Double vision	0.19	±0.54	0.06	±0.25	0.19	±0.54	0.19	±0.54
Pain in the eye	0.43	±0.81	0.31	±0.60	0.87	±1.15	1.12*	±1.31
Blurred vision	0.37	±0.88	0.50	±0.97	0.50	±0.89	0.37	±0.81
Needing to reread the text	1.25	±0.86	1.25	±0.77	1.31	±0.70	1.37	±0.88

Note: The questionnaire use a score between 0-4: (0) Never; (1) Seldom; (2) Sometimes; (3) Often; (4) Constantly.

* Significant difference between the 2000 cd/m^2 and 6000 cd/m^2 lighting conditions.

5 DISCUSSION

The overall aim of this research was to investigate different glare conditions commonly present in a computer work environment and in addition to determine the severity of glare conditions by evaluating the impact on the capacity for binocular coordination and eye movements when reading. The theories on which the research in this thesis was based on were that disability glare itself and in combination with the lack of three-dimensional (3D) features in the central visual field contributes to asthenopia. It has been demonstrated that computer work is a demanding near visual task that contributes to an increased occupational visual work load that gives rise to computer vision syndrome, CVS (for a review, see Rosenfield, 2011). It is a common knowledge that CVS typically occurs after prolonged computer-related visual activity. Disability glare and the lack of 3D features further increase the work load by reducing stimuli contrast, the contrast of the retinal image and the stimuli for vergence control.

The four studies that this thesis is based on investigated the effect of 3D as compared to only two-dimensional (2D) features in the central most visual field on vergence control (study I, Paper I); evaluated the influence of glare on fixation disparity (FD) while performing computer work (study II, Paper II); evaluated the effect of glare on eye movements when reading on a computer screen (study III, Paper III); and determined the threshold luminance value for direct disability glare using repeated FD measurements as a benchmark while performing computer work (study IV, Paper IV). The fourth study also included subjective grading of the impact of glare on computer work performance.

In the first study (Paper I) a target with centrally placed 3D features was used while performing near point of convergence (NPC) measurements. This demonstrated that vergence control improved with the presence of 3D features, a finding that concurs with the results of Blythe et al. (2012), who found that the vergence system seemed to be more sensitive and responsive to disparity cues in the fovea. Their results showed that using stereoscopic images (3D stimuli) enhances depth-appropriated vergence response. Using centrally placed 3D features while measuring NPC provided a significantly better average NPC value. Repeated measurements with the 3D test target were found to result in less remote NPC values. These findings indicated that vergence control is reduced when the most central element of the visual task only embodied 2D features. Moreover, Blythe et al. (2012) found an inefficiently adapted vergence response to parafoveal disparity cues. This supports our proposed explanation that 3D stimuli act as a fusional guidance for fixations leading to an increase in fixation accuracy and stability. Accordingly, we may expect that subjects with the most remote NPC under 2D conditions have a less remote NPC under 3D conditions.

The visual environment in which work with computers, tablets or mobile phones takes place lacks 3D features in the central part of the visual field. Our findings in the first study make it reasonable to believe that the 2D visual environment for computer work contributes to related visual symptoms, i.e. CVS. Additionally, since the stimuli supporting the vergence control

are limited and the fact that long periods are spent working with different types of screens vergence control is negatively affected and symptoms arise.

In the second study (Paper II) we found that the variation within FD measurements increased with severity of glare condition while working with computers. The result showed that the variation was significantly higher in the direct glare lighting condition. Our findings confirm previous reports identifying degradation of stimuli contrast in relation to a reduction of the capacity for binocular coordination, i.e. blur had a strong effect on FD (Jainta et al., 2011; Jaschinski-Kruza, 1994; Pickwell et al., 1987). Previous research has similarly found that degradation contributed to a reduction of the quality of the disparity vergence system. Further, since disability glare degraded the visibility of the work task, there was a reduction of image and image contrast cues for fine alignment. In other words, a disruption of binocular vision was present. Our findings in this study support the contention that the accommodation and vergence mechanism was affected when blur of the retinal image and/or the visual task increased. FD derives from the components of the control mechanism of disparity vergence and accommodation (Hung, 1992). These results indicate that glare placed higher demands on the oculomotor system to maintain precise adjustment. Increased demands on the oculomotor system are strongly associated with asthenopia (Goss, 1995). If we divide asthenopia on the basis of internal and external symptoms, internal symptoms are believed to be due to the vergence or accommodation mechanism and include eyestrain, headache, eye pain, diplopia and blur (Portello et al., 2012; Sheedy et al., 2003). Our findings support the hypothesis that disability glare had a negative effect on binocular vision. The results indicated that the variation within FD measurements would probably be a better indicator of visual stress, i.e. visual fatigue (Tyrell & Leibowitz, 1990), than the average value. In this study we used representative luminance levels (SS-EN 12464-1) except for the direct glare condition. Although subjects in this study had normal binocular vision, FD was induced by glare.

In study III (Paper III) reading speed was found to decrease with adverse lighting conditions while performing computer work. The result was mainly the outcome of increased fixation durations. A comparison of pre- and post IReST texts (standardized texts) indicated that reading speed were comparable in direct - and indirect glare conditions. Reading speed was considered to be higher in lighting conditions with moderate glare and no glare. Induced indirect glare and direct glare resulted in increased fixation rates, longer fixation durations and increased saccade rate with shorter lengths. This result was derived from analysis of the second IReST texts. This is in line with an earlier report that determined that saccade amplitude decreased and fixation duration increased to blur the visual task, i.e. the stimulus was readable but substantially out of focus (Jainta et al., 2011). Their findings also indicated the impact of blur on the disparity-driven fine-tuning of the vergence adjustments. Because of the blurred image there was reduction of these vergence adjustments in terms of high spatial frequencies.

Additionally, this study included comprehension questions which showed no difference between lighting conditions. This indicates that it takes more time to read in improper

lighting condition to attain the same degree of reading comprehension, which therefore corresponds to a reduction in reading speed related to the severity of lighting condition. In study II (Glimne et al., 2013) we found that glare had an adverse effect on binocular coordination due to a reduced capacity of the accommodation and vergence mechanism. These findings support the view that environmental factors are an indicator of visual stress. As there were equal differences in the lighting conditions used in this study it is reasonable to speculate that reduced binocular coordination (FD) caused by disability glare results in reduced reading performance found here. In one study the authors proposed that reading speed is limited by the number of letters recognized in parallel, i.e. visual span (Legge et al., 2001). Further, they concluded that eccentric stimuli (retinal eccentricities) decrease the visual span. Their explanation of this phenomenon was therefore that the reader recognized fewer letters per fixation and in consequence saccades become smaller with a corresponding decline in reading speed. Our findings in this study support the hypothesis that glare has a negative effect on eye movements when reading and these demonstrated that both direct and indirect glare affected eye movements significantly. The results suggest that degradation of stimuli contrast and the contrast of the retinal image impairs eye movements when reading. These findings are consistent with a number of previous reports (Ojanpää & Näsänen, 2003; Bowers & Reid, 1997; Legge et al., 1997). The illuminance levels used in this study were typical for computer workplaces (SS-EN 12464-1). Although all the subjects in this study had normal eye movement glare impacted negatively on reading eye movements.

In the fourth study (Paper IV) we aimed to implement an objective measurement of the quality of binocular coordination (FD) as a benchmark. This study was designed to determine the luminance threshold of direct glare while performing computer work. In addition to the measurement of FD, a subjective grading of the impact of glare was included. Direct glare appears to reduce visibility highly. This was observed in a study where the subjects' eyes were placed approximately 19-22° below horizontal eye level while performing computer tasks. Using FD measurement as a guide to the quality of binocular vision i.e. binocular coordination, has previously (study II, Glimne et al., 2013) turned out to be a valuable tool for evaluating the impact of the visual environment on accommodation and vergence systems. Earlier report concluded that disability glare places stress on binocular vision due to the decreased visibility of the visual task (Jainta et al., 2011; Jaschinski-Kruza, 1994; Pickwell et al., 1987). Induced glare conditions were set to 2000 cd/m², 4000 cd/m² and 6000 cd/m². We found in this study that direct glare of 2000 cd/m² affects the stability of fixation negatively with an induced pain level in the eyes when performing tasks binocularly. According to the result in this study it seems reasonable to recommend that stray light toward the eyes (direct glare) should be significantly lower than 2000 cd/m².

Decreased visibility causes eye-related problems, anxiety, tiredness and loss of visual performance. In addition to the sources included in this thesis the phenomenon can be furthermore due to frequent changes to adapt to different luminance levels and contrast glare. This has been recorded in the in driver's cab of a commuter train (for further detailed

information, see “Supplementary work”). Both disability glare and discomfort glare with severe light sensitivity were increasingly present in work conditions where the visual ergonomic aspects did not follow recommendations. Direct sunlight and high brightness contrast caused visual discomfort at work. The symptoms that most often accompany this condition were eye fatigue, tearing, headache and light sensitivity.

5.1 CLINICAL GUIDANCE

The results, based on the included studies in this thesis, can be a complementary basis to further show that there are major advantages to consider visual ergonomics related to computer work environments. Since computer work is visually demanding task several aspects of visual function should be evaluated among computer users. Clinical guidance is therefore included in this thesis.

5.1.1 Computer workplace environment

In order to avoid further instability of binocular fixation and impairment of reading behaviour neither direct nor indirect glare should be present in the computer worker’s visual field.

Computer users suffering from binocular problems are likely to experience visual discomfort even at low luminance values regarding lighting conditions which induce disability glare. Therefore, special care must be taken to enable computer workers with binocular problems to avoid oculomotor imbalance.

5.1.2 Optometric considerations

There are several visually related differences between performing near visual tasks using display devices as compared to reading printed text. These include reading distance, gaze angle and font size. In optometric practice reading distance is traditionally assumed to be 40 cm and reading performed with a downward gaze angle, i.e. what was considered the natural way of viewing a newspaper or printed book while seated and holding the text at a “comfortable” distance with one’s arms and hands. A 40 cm viewing distance and downward gaze is still the golden standard for normal optometric testing. However, with display units (i.e. computer screens) a viewing distance of 40 cm with a downward directed gaze similar to reading a book/newspaper is not a standard. Computer screens are often placed further away than 40 cm and the direction of gaze is closer to straight ahead than downwards.

According to Bhandari et al. (2008) 10-15% of routine eye examinations are due to CVS-related symptoms. However, standard optometric testing procedures will identify few of the CVS subjects as being in need of special correction or other needs. The distances and gaze angles tested do not match the way in which the subjects use their eyes while doing computer work. Rosenfield (2011) therefore proposed changes in routine eye examination in order to detect and help subjects with CVS. His suggestions included recommending the use of near visual function tests. Tests should consider requirements of oculomotor assessment in multiple viewing distances and gaze angles. Further, the practitioners should consider the

need to correct small refractive errors if they are associated with prolonged display-related work in conjunction with the specific viewing distance of the screen.

5.1.3 Age related considerations

For elderly workers assessment of glare problems and reduced contrast should be considered in addition to common assessment tests of visual function. Supplementary test are required because of ocular changes associated with increasing age, e.g. natural aging of the lens, degenerative processes in the retina, decreased contrast sensitivity, reduced night vision, increased glare sensitivity, as well as changes in refraction accommodative capacity and pupil size (Grosvenor, 2007; Neitz & Neitz, 2000).

5.2 FUTURE RESEARCH

There are several additional topics for further research that have been highlighted by the studies undertaken during this thesis.

The effects of glare on binocular coordination and eye movements when reading in subjects older than 45 years of age and in subjects who have a diagnosed weakened function of the vergence system, were outside the scope of this thesis. Subjects with a weakened vergence system are likely to be affected more negatively by glare than the study population evaluated in this thesis. Further research will therefore explore if this assumption is true. In subjects older than 45 years of age ocular diseases, especially cataract, are more common. Cataract will increase the sensation of glare and further research will therefore evaluate threshold glare levels in subjects with cataract. For all computer workers glare is likely to reduce productivity and efficiency. It would therefore be interesting to evaluate if threshold glare levels can be defined to optimize productivity and efficiency.

6 CONCLUSIONS

The theoretical framework presented in this thesis comprises computer work as a stationary demanding near visual task and hence more susceptible to environmental factors such as incorrect workplace lighting design.

Based on the results of this thesis the following conclusions were reached:

- The occurrence of three-dimensional (3D) features in the most central element of the visual task provided a significantly better average value of near point of convergence. A two-dimensional (2D) visual environment contributes to deterioration of binocular coordination due to a weakened vergence. Therefore, we argue for a more pronounced relationship between reduced cues of centrally placed 3D features when working with computers with elevated exposure to disability glare.
- Disability glare impaired the disparity vergence system. The result showed that the variation within fixation disparity measurements was significantly higher in the direct glare lighting condition. Glare induced an increased instability of fixation as a result of stress on binocular vision, i.e. an increased oculomotor load. Oculomotor load increased with the severity of the glare condition while performing computer work and may therefore be a contributory factor to computer vision syndrome (CVS). This fact is an important aspect to take into account with regard to computer workers with binocular problems since they are more likely to experience visual discomfort due to oculomotor imbalance under working conditions of glare even at levels lower than those present in these studies.
- Reading speed was found to decrease with adverse lighting conditions while performing computer work. The result was mainly the outcome of increased fixation durations. Induced indirect glare and direct glare resulted in increased fixation rates, longer fixation durations and increased saccade rate with shorter lengths. The result indicated that it takes more time to read in improper lighting condition to attain the same degree of reading comprehension, which therefore corresponds to a reduction in reading speed related to the severity of lighting condition.
- Direct glare of 2000 cd/m^2 affects the stability of fixation negatively with an induced pain level in the eyes when performing tasks binocularly. The introduction of a subjective assessment of the impact of glare in addition to objective measurement of the quality of binocular coordination as a benchmark makes it reasonable to recommend that stray light toward the eyes should be significantly lower than 2000 cd/m^2 .

The research findings presented in this thesis support the relevance of providing an optimized visual environment that takes into account lighting design in computer workplaces.

7 ACKNOWLEDGEMENTS

This thesis is a fruit of a long and challenging journey with a passionate interest in the topic of visual ergonomics. This thesis represents not only my academic education and research work it is also a milestone in my life.

I want to express my warm and genuine gratitude to those who had, in many ways, been involved generously supported and encouraged me during all this years and made this thesis possible. A number of people greatly contributed. I am severely thankful to mentors, colleagues, friends and family members, some of whom are mentioned here:

Firstly, I would like to express my sincere gratitude to my main supervisor, Associate Professor **Rune Brautaset**, for the continuous support of my Ph.D. study and related research, for your patience, motivation, and tremendous knowledge. You have always been there for me willing to share your time contributing to move my work forward in the right direction.

I owe my deepest gratitude to my co-supervisors. Without their continuous optimism concerning this work, enthusiasm and support this thesis would hardly have been completed. Ph.D. **Gustaf Öqvist Seimyr**, for providing me with brilliant advices and valuable tools. Adjunct Professor **Kristina Teär Fahnehjelm** and Associate Professor **Per Nylén**, for your constant support, excellent guidance and motivation.

I benefited greatly from many fruitful discussions with my colleague and mentor Senior Lecturer Ph.D. **Maria Nilsson**. Thank you for your patient guidance, enthusiastic encouragement and useful advices. I would also like to extend my appreciation for being chairperson at the public defense.

Over the research educational years of my Ph.D. project I have had the opportunity to be guided by several supervisors: Professor **Per Söderberg** at Uppsala Universitetet, Department of Neuroscience, Associate Professor **Stefan Löfgren** at Karolinska Institutet, Department of Clinical Neuroscience, Professor and Senior Physician **Jan Ygge** at Karolinska Institutet, Department of Clinical Neuroscience. I offer my sincere appreciation for the opportunity to do this project and for believing in me.

I would like to express my very great appreciation to **Optikbranschen** for important financial contribution.

It is a great pleasure to thank my dearest colleagues at the Unit of Optometry for having a supportive spirit and great understanding during this project: Ph.D. **Anna Lindskoog Pettersson**, **Annika Botes**, **Elin Zetterberg**, Ph.D. **Fredrik Källmark**, **Inga-Lill Thunholm-Henriksson**, **Jaana Johansson**, **Kerstin Lutteman**, **Lovisa Pettersson**, Ph.D. **Marika Wahlberg Ramsay**, **Monica Ferrato Sandén**, **Rebecka Rosén**, **Sten Lutteman**, **Ulla Bremö**, and **Ulrika Birkeldh**.

I wish to thank the staff at Marianne Bernadotte Center for your support and generosity, not forgetting your open-hearted humor and wonderful coffee breaks with much laughter: Associate Professor **Agneta Rydberg**, **Annika Pettersson**, **Jan Johansson**, Ph.D. **Mattias Nilsson Benfatto**, and Ph.D. **Monica Olsson**. Special thanks to Associate Professor **Tony Pansell**. I am truly grateful for valuable advice and discussions involving both this research project and future projects. I would like to thank **Mia Pettersson** and **Ulla-Britt Schützler-Peterson**, administrators at our department, for their endless help with all administrative matters during my Ph.D. project.

I also place on record, my sense of gratefulness to one and all, who directly or indirectly, have lent their time contributing to my research work during this project.

I wish to thank all my friends for everlasting friendship and for always being there for me. I am grateful to my parents, brothers and their families; **Anneli**, **Age**, **Jan** and **Stefan**, for supportive encouragement throughout the years.

Finally, to my caring, loving and supportive family: I would like to express my deepest gratitude and heartfelt thanks to **Kenneth**, my love of my life. Your encouragement when time got rough is truly appreciated. You always believed in me and motivated me to complete this project. To my wonderful son and daughter, **Gustav** and **Emelie**, you have so much patience.

8 REFERENCES

- Aarås A, Horgen G, Bjørset HH, Ro O, Thoresen M. Musculoskeletal, visual and psychosocial stress in VDU operators before and after multidisciplinary ergonomic interventions. *Appl Ergon.* 1998;29:335–354.
- Aarås A, Horgen G, Bjørset HH, Rod O, Wals H. Musculoskeletal, visual and psychosocial stress in VDU operators before and after multidisciplinary ergonomic interventions. A 6 years prospective study - Part II. *Applied Ergonomics.* 2001;32:559–571.
- Aarås A, Horgen G, Ro O, Løken E, Mathiasen G, Bjørset HH, Larsen S, Thoresen M. The effect of an ergonomic intervention on musculoskeletal, psychosocial and visual strain of VDT data entry work: the Norwegian part of the international study. *Int J Occup Saf Ergon.* 2005;11(1):25–47.
- Allen MJ, Vos JJ. Ocular scattered light and visual performance as a function of age. *Am J Optom Arch Am Optom.* 1967;44:717–727.
- American Optometric Association. AOA. <http://www.aoa.org>. Last accessed: June 20, 2015.
- Anshel, J. *Visual Ergonomics Handbook*. USA: Taylor & Francis Group: 2005.
- Bass M (ed.), *Handbook of Optics Volume II - Devices, Measurements and Properties*, 2nd Ed. USA: McGraw-Hill: 1995;24–40.
- Bailey IL, Bullimore MA. A new test for the evaluation of disability glare. *Optometry & Vision Science.* 1991;68(12):911–917.
- Benjamin WJ, editor. *Borish's clinical refraction*. 2nd ed. Oxford (UK): Butterworth-Heinemann: 2006.
- Bhanderi DJ, Choudharg S, Doshi VG. A community based study of asthenopia in computer operators. *Indian J Ophthalmol.* 2008;56:51–55.
- Björnsson CH. *Läsbarhet*. Stockholm. Liber: 1968.
- Blythe HI, Holliman NS, Jainta S, Tbaily LW, Liversedge SP. Binocular coordination in response to two-dimensional, three-dimensional and stereoscopic visual stimuli. *Ophthalmic & Physiological Optics: The journal of the British College of Ophthalmic Opticians (Optometrists).* 2012;32(5):397–411.
- Bowers R, Reid VM. Eye movements and reading with simulated visual impairment. *Optom.* 1997;17(5):392–402.
- Brainard DH. The psychophysics toolbox. *Spat. Vis.* 1997;10:433–436.

Bureau of Labor Statistics. U.S Department of Labor. Report USDL-14-2246: Nonfatal Occupational Injuries and Illnesses Requiring days away from Work, 2013. Retrieved August 24, 2015 from: <http://www.bls.gov/news.release/pdf/osh2.pdf>

Burian HM, von Noorden GK. Binocular vision and ocular motility. St Louis: C.V. Mosby Ltd: 1974.

Culhane HM, Gilmartin B. Human dynamic closed-loop accommodation by sympathetic inhibition. *Invest. Ophthalmol. Vis. Sci.* 1999;40:1137–1143.

Cumming BG, Parker AJ. Responses of primary visual cortical neurons to binocular disparity without depth perception. *Nature.* 1997;389(6648):280–283.

Curcio CA, Sloan KR, Kalina RE, Hendrickson AE. Human photoreceptor topography. *Journal of Comparative Neurology.* 1990;292(4):497–523.

Euler L. Recherches syr une nouvelle esp ece de quarrès magiques. *Verh Zeeuwsch Genoot Weten Vliss.* 1782;9:85–239. In: Kotz S. *Encyclopedia of Statistical Sciences*, Volym 5. New Jersey: John Wiley & Sons: 2006.

Fincham EF. The accommodation reflex and its stimulus. *Br. J. Ophthalmol.* 1951;35(7):381–393.

Garzia RP. *Vision and reading.* Mosby-Year Book, Inc., St. Louis Missouri, USA: 1996. 102–103.

Gilmart B, Mallen EAH, Wolffsohn JS. Sympathetic control of accommodation: evidence for inter-subject variation. *Ophthal. Physiol. Opt.* 2002;22:366–371.

Glimne S, Seimyr GÖ, Ygge J, Nylén P, Brautaset RL. Measuring glare induced visual fatigue by fixation disparity variation. *Work.* 2013;45(4):431–437.

Goss DA. *Ocular accommodation, convergence, and fixation disparity: a manual of clinical analysis* (2nd ed.). Newton, USA: Butterworth-Heinemann: 1995;67–75.

Grosvenor T. Primary Care Optometry. In: *Age-related vision problems.* St. Louis, Missouri: Butterworth-Heinemann. Elsevier Inc: 2007.

Han CC, Liu R, Liu RR, Zhu ZH, Yu RB, Ma L. Prevalence of asthenopia and its risk factors in Chinese college students. *Int J Ophthalmol.* 2013;6(5):718–722.

Heath GG. Components of accommodation. *Am. J. Optom. Arch. Am. Acad. Optom.* 1956;33:569–578.

Helland M, Horgen G, Kvikstad TM, Garthus T, Aaras A. Will musculoskeletal, visual and psychosocial stress change for visual display unit (VDU) operators when moving from a single occupancy office to an office landscape? *Int J Occup Saf Ergon.* 2008;14:259–274.

- Hemphälä H, Eklund J. A visual ergonomics intervention in mail sorting facilities: Effects on eyes, muscles and productivity. *Applied Ergonomics*. 2012;43(1):217–229.
- Henson DB, North R. Adaptation to prism-induced heterophoria. *Am. J. Optom. Physiol. Opt.* 1980;57:129–137.
- Horgen G, Aarås A, Dainoff MJ, Konarska M, Thoresen M, Cohen BG, et al. A cross-country comparison of short- and long-term effects of an ergonomic intervention on musculoskeletal discomfort, eyestrain and psychosocial stress in VDT operators: selected aspects of the international project. *Int J Occup Saf Ergon.* 2005;1:77–92.
- Howard IP, Rogers BJ. *Binocular vision and stereopsis*. New York: Oxford University Press: 1995.
- Hung GK. Adaptation model of accommodation and vergence. *Ophthalmol Physiol Opt.* 1992; 12:319–326.
- Hung K. *Models of Oculomotor Control*. River Edge, NJ, USA: World Scientific Publishing, Singapore. 2001. ProQuest ebrary. Web. 26 June 2015.
- Illuminating Engineering Society. *IES recommended practice for lighting offices containing computer visual display terminals*. (New York: Illuminating Engineering Society of North America, IESNA). 1989.
- International Organization for Standardization (ISO). *Ergonomics of human-system interaction- Part 302: Terminology for electric visual displays (Standard No. ISO 9241–302:2008)*. Geneva, Switzerland: ISO. 2008.
- Jainta, S, Dehnert A, Heinrich SP, Jaschinski W. Binocular coordination during reading of blurred and nonblurred text. *Investigate Ophthalmology & Visual Science*. 2011;52(13):9416–9424.
- Jainta S, Jaschinski W. Fixation Disparity: Binocular Vergence Accuracy for a Visual Display at Different Positions Relative to the Eyes. *Human Factors*. 2002;44(3):443–450.
- Jaschinski W. Fixation disparity at different viewing distances and the preferred viewing distance in a laboratory near-vision task. *Ophthalm. Physiol. Opt.* 1998;18(1):30–39.
- Jaschinski, W. Fixation disparity and accommodation for stimuli closer and more distant than oculomotor tonic positions. *Vision Research*. 2001;41:923–933.
- Jaschinski-Kruza W. Fixation disparity at different viewing distances of a visual display unit. *Optical. Physiol. Opt.* 1993;13(1):27–34.
- Jaschinski-Kruza W. Eyestrain in VDU Users: Viewing Distance and the Resting Position of Ocular Muscles. *Human Factors: The Journal of the Human Factors and Ergonomics Society* 1991;33(1): 69–83.

- Jaschinski-Kruza W. Dark vergence in relation to fixation disparity at different luminance and blur levels. *Vision Res.* 1994;34(9):1197–1204.
- Johansson J, Pansell T, Ygge J, Seimyr GÖ. Monocular and binocular reading performance in subjects with normal binocular vision. *Clinical and Experimental Optometry.* 2014;97(4):341–348.
- Ko P, Mohapatra A, Bailey IL, Sheedy J, Rempel DM. Effect of font size and glare on computer tasks in young and older adults. *Optometry & Vision Science.* 2014;91(6):682–689.
- Le Claire J, Nadler MP, Weiss S, Miller D. New glare tests for clinical testing. *Arch Ophthalmol.* 1982;100:153–158.
- Legge GE, Mansfield JS, Chung ST. Psychophysics of reading: XX. Linking letter recognition to reading speed in central and peripheral vision. *Vision research.* 2001; 41(6): 725–743.
- Legge GE, Ahn SJ, Klitz TS, Luebker A. Psychophysics of reading: XVI. The visual span in normal and low vision *Vision. Res.* 1997;37:1999–2010.
- Lie I, Watten R. Oculomotor factors in the aetiology of occupational cervico-brachial diseases (OCD). *Eur J Physiol.* 1987;56:151–156.
- Lighting Research Center. Illuminating Engineering Society of North America (IESNA). February 2007. Retrieved August 21, 2015 from:
<http://www.lrc.rpi.edu/programs/nlpip/lightinganswers/lightpollution/glossary.asp>
- Ljspeert JK, de Waard PWT, van den Berg TJTP, de Jong PTVM. The intraocular straylight function in 129 healthy volunteers; dependence on angle, age and pigmentation. *Vision Res.* 1990;30:699–707.
- Maddox EE. Investigations in the Relation between Convergence and Accommodation of the Eyes. *J Anat Physiol.* 1886; 20:565–584.
- McClure ME, Hart PM, Jackson AJ, Stevenson MR, Chakravarthy U. Macular degeneration: do conventional measurements of impaired visual function equate with visual disability? *British Journal of Ophthalmology.* 2000;84(3):244–250.
- Miles FA. Adaptive regulation in the vergence and accommodation control systems. *Rev. Oculomot. Res.* 1985;1:81–94.
- Mocci F, Serra A, Corrias GA. Psychological factors and visual fatigue in working with video display terminals. *Occup Environ Med.* 2001;58:267–271.
- Neitz M, Neitz J. Molecular genetics of color vision and color vision defects. *Arch Ophthalmol.* 2000;118(5): 691–700.

Nilsson M, Stevenson B, Leach N, Bergmanson JP, Brautaset R. Vertical imbalance induced by prism-ballasted soft toric contact lenses fitted unilaterally. *Ophthalmol. Physiol. Opt.* 2008;28:1–6.

Nilsson A, Nilsson M, Stevenson SB, Brautaset RL. The influence of unilateral uncorrected astigmatism on binocular vision and fixation disparity. *Strabismus.* 2011;19(4):138–141.

Nuthmann, A. Eye movements and visual cognition lecture 2. 2014, September: University of Edinburgh, UK.

Nylén P, Favero F, Glimne S, Teär Fahnehjelm K, Eklund J. Vision, light and aging: A literature overview on older-age workers. *Work.* 2014;47:399–412.

Ogle KN, Prangen AD. Further considerations of fixation disparity and the binocular fusional process. *Am. J. Ophthalmol.* 1951;34:57–72.

Ogle KN, Prangen AD. Observations on vertical divergences and hyperphorias. *Arch. Ophthalmol.* 1953;49:313–334.

Ojanpää H, Näsänen R. Effects of luminance and colour contrast on the search of information on display devices. *Displays.* 2003;24:167–178.

O'Regan JK. Eye movements and reading. In E. Kowler (Ed.), *Eye movements and their role in visual and cognitive processes.* New York: Elsevier: 1990; 395–453.

O'Regan JK. Understanding visual search and reading using the concept of stimulus "grain". *IPO Annual Progress Reports.* 1991;26:96–108.

Pelli DG. The Video Toolbox software for visual psychophysics: transforming numbers into movies. *Spat. Vis.* 1997;10:437–442.

Pelli DG, Bex P. Measuring contrast sensitivity. *Vision Research.* 2013;90:10–14.

Piccoli B. A critical appraisal of current knowledge and future directions of ergophthalmology: consensus document of the ICOH Committee on 'Work and Vision'. *Ergonomics.* 2003;46(4):384–406.

Pickwell L D. *Binocular vision anomalies – investigation and treatment, third edition.* London, UK: Butterworth-Heinemann: 1997;53–61.

Pickwell L D, Yekta A A, Jenkins T C A. Effects of reading in low illumination on fixation disparity. *Am. J. Optom. Physiol. Opt.* 1987;64:513–518.

Pitts DG, Kleinstein OD. *Environmental Vision. Interactions of the Eye, Vision, and the Environment.* Stoneham, USA. Butterworth-Heinemann: 1993;116–1128.

Portello JK, Rosenfield M, Bababekova Y, Estrada JM & Leon A. Computer-related visual symptoms in office workers. *Ophthalmic Physiol Opt.* 2012;32:375–382.

- Portello JK, Rosenfield M, Chu CA. Blink Rate, Incomplete Blinks and Computer Vision Syndrome. *Optometry and Vision Science*. 2013;90(5):482–487.
- Radner W, Obermayer W, Richter-Mueksch S, Willinger U, Velikay-Parel M, Eisenwort B. The validity and reliability of short German sentences for measuring reading speed. *Graefes Arch Clin Exp Ophthalmol*. 2002;240:461–467.
- Rayner K. Eye movements in reading and information processing. *Psychological Bulletin*. 1978;85:618–660.
- Rayner K. Eye movements in reading and information processing: 20 years of research. *Psychological Bulletin*. 1998;124(3):372–422.
- Rea MS. *Lighting handbook reference & application*. 9th ed. New York: Illuminating Engineering Society of North America (IESNA). 2000.
- Richter HO, Bänziger T, Forsman M. Eye-lens accommodation load and static trapezius muscle activity *Eur J Appl Physiol*. 2011(a);111:29–36.
- Richter HO, Zetterlund C, Lundqvist L-O. Eye-neck interactions triggered by visually deficient computer work. *Work*. 2011(b);39(1):67–78.
- Richter HO, Lodin C, Forsman M. Temporal aspects of increases in eye-neck activation levels during visually deficient near work. *Work*. 2012;41(1):3379–3384.
- Robertson MM, Huang YH, Larson N. The relationship among computer work, environmental design, and musculoskeletal and visual discomfort: examining the moderating role of supervisory relations and co-worker support. *International archives of occupational and environmental health*. 2015:1–16. Epub, DOI 10.1007/s00420-015-1046-x.
- Rosenfield M. Computer vision syndrome: a review of ocular causes and potential treatments. *Ophthalmic Physiol Opt*. 2011;31:502–515.
- Rosenfield M, Gilmartin B. Temporal aspects of accommodative adaptation. *Optom. Vis. Sci*. 1989;66:229–234.
- Rossignol AM, Morse EP, Summers VM, Pagnotto LD. Visual display terminal use and reported health symptoms among Massachusetts clerical workers. *J. Occup. Med*. 1987;29:112–118.
- Sanchez-Roman FR, Pererz-Lucio C, Juarez-Ruiz C, Velez-Zamora NM, Jimenez-Villarruel M. Risk factors for asthenopia among computer terminal operators. *Salud Publica Mex*. 1996;38:189–196.
- Sauter SL, Schleifer LM, Knutson SJ. Work posture, workstation design, and musculoskeletal discomfort in a VDT data entry task. *Human Factors*. 1991;33(2):151–167.

Schiøtz Thorud, H-M, Helland M; Aarås A, Kvikstad, T M, Lindberg LG, Horgen G. Eye-Related Pain Induced by Visually Demanding Computer Work. *Optometry & Vision Science*. 2012;89(4):452–464.

Schor CM. Adaptive regulation of accommodative vergence and vergence accommodation. *Am. J. Optom. Physiol. Opt.* 1986;63:587–609.

Schwartz S. *Visual Perception: A Clinical Orientation, Fourth Edition*. U.S. McGraw-Hill Medical: 2010;44–54. ISBN: 9780071604611

Sheedy JE, Hayes J, Engle J. Is all asthenopia the same? *Optom Vis Sci*. 2003;80:732–739.

Sheedy JE, Shaw-McMinn PG. *Diagnosis and Treating Computer-Related Vision Problems*. Butterworth-Heinemann. Elsevier Science, Inc: 2003;2–5.

Sheedy JE, Smith R, Hayes J. Visual effects of the luminance surrounding a computer display. *Ergonomics*. 2005;48:1114–1128.

SS-EN 12464-1, SIS. Ljus och belysning - Belysning av arbetsplatser - Del 1: Arbetsplatser inomhus. SIS, Swedish Standards Institute, Stockholm. 2011.

The Work Environment 2013. The Swedish Work Environment Authority (SWEA). *Arbetsmiljöstatistik Rapport 2014:3*. ISSN 1652-1110. June 2014. Retrieved August 24, 2015 from: http://www.av.se/dokument/statistik/officiell_stat/ARBMIL2013.pdf

Trauzettel-Klosinski S, Dietz K, and the IReST study group. Standardized Assessment of Reading Performance: The New International Reading Speed Texts (IReST). *Invest. Ophthalmol. Vis. Sci*. 2012;53(9):5452–5461.

Tunnacliffe AH. *Introduction to Visual optics*. 4th edition. The Association of British Dispensing Opticians. UK, London. ABDO. 1997.

Turville KL, Psihogios JP, Ulmer TR, Mirka GA. The effects of video display terminal height on the operator: a comparison of the 15° and 40° recommendations. *Applied Ergonomics*. 1998;29(4):239–246.

Tyrrell RA, Leibowitz HW. The relation of vergence effort to reports of visual fatigue following near work. *Human Factors*. 1990;2:341–357.

U.S. Department of Labor. Safety with video display terminals, Fact Sheet:1995;95–24.

Wahlström J, Hagberg M, Toomingas A, Wigaeus Tornqvist E. Perceived muscular tension, job strain, physical exposure, and associations with neck pain among VDU users; a prospective cohort study. *Occupational and Environmental Medicine*. 2004;61(6):523–528.

Wiholm C, Richter H, Mathiassen, SE, Toomingas, A. Associations between eyestrain and neck-shoulder symptoms among call-center operators. *Scandinavian Journal of Work Environment and Health*. 2007;3:54–59.

- Winn B, Culhane HM, Gilmartin B, Strang NC. Effect of β -adrenoceptor antagonists on autonomic control of ciliary smooth muscle. *Ophthal. Physiol. Opt.* 2002;22:359–365.
- Wolska A, Sawicki D. Evaluation of discomfort glare in the 50+ elderly: experimental study. *Int J Occup Med Environ Health.* 2014;27(3):444–459.
- Work-related disorders 2012. The Swedish Work Environment Authority (SWEA). *Arbetsmiljöstatistik Rapport 2012:5.* ISSN 1652-1110. September 2012. Retrieved August 24, 2015 from: http://www.av.se/dokument/statistik/officiell_stat/ARBORS2012.pdf
- Yekta AA, Jenkins T, Pickwell D. The clinical assessment of binocular vision before and after a working day. *Ophthalmic and Physiological Optics.* 1987;4:349–352.
- Zetterberg C, Richter HO, Forsman M. Temporal Co-Variation between Eye Lens Accommodation and Trapezius Muscle Activity during a Dynamic Near-Far Visual Task. *PLoS ONE.* 2015;10(5):e0126578.
- Zetterlund C, Lundqvist L.O, Richter HO. The relationship between low vision and musculoskeletal complaints. A case control study between age-related macular degeneration patients and age-matched controls with normal vision. *Journal of Optometry.* 2009;2(3):127–133.
- Qian N. Binocular disparity and the perception of depth. *Neuron.* 1997;18:359–368.
- Öquist G. Evaluating readability on mobile devices. PhD Thesis in Computational Linguistics. Department of Linguistics, Uppsala University. 2006. Retrieved August 24, 2015 from: <http://uu.diva-portal.org/smash/get/diva2:800998/FULLTEXT02.pdf>

9 SUPPLEMENTARY WORK

During a six-month period between May and September, 2014, the author of this thesis undertook a survey focusing on visual ergonomics in the driver's cabs of commuter trains. The main purpose was to assess the need for work-related optometric correction. The survey was carried out using a questionnaire, in-depth interviews and by accompanying five train drivers in the cab. Assessment of the need for work-related optometric correction was based on the relevant regulations and guidelines from the Swedish Work Environment Authority (SWEA) in view of vision defects and age-related physiological changes relating to frequent changes in focusing distance.

The visual ergonomic aspects of the commuter cab were described for three different lighting conditions: daylight, twilight and night driving. Three of the five drivers described ocular problems they experienced as work-related. The symptoms that most often accompany this condition were eye fatigue, tearing, headache and light sensitivity. All of the drivers described a work-related increase of discomfort glare and disability glare due to disparity in luminance, i.e. contrast glare, within the visual field. Contrast glare affected their ability to see clearly while working in their cab (for specific information regarding luminance- and illuminance levels, see table 7). Contrast glare occurred in both the central and the peripheral field of vision (for illustration of the cab, see figure 18). Experiences of severe light sensitivity were described by two of the five train drivers. When driving at night similar glare-related eye problems were experienced due to high luminance on the dashboard, signal lights next to the railroad tracks, and from oncoming trains in environments with otherwise low luminance.

Table 7. Measured values (cd/m^2 and Lux) in driver's cab of commuter trains.

Measured surface (within visual field)	Luminance (cd/m^2)	Illuminance (Lux) Horizontal
On Left/Right side - In front of dashboard	Hazy: 5-20 Cloudy: 150-650 Sunny: 1,300-1,500	Hazy: 10-20 Cloudy: 1,200-6,000 Sunny: 20,000-40,000
In front of dashboard	Hazy: 25-50 Cloudy: 250-400 Sunny: 1,500-2,500	Hazy: 10-80 Cloudy: 3,500-10,500 Sunny: 20,000-40,000
Top side of dashboard	Hazy: 5-10 Cloudy: 80-100 Sunny: 600-900	Hazy: 5-10 Cloudy: 700-1,200 Sunny: 15,000-30,000
Dashboard with neighbouring areas	Hazy: 0.5-10 Cloudy: 80-100 Sunny: 350-700	Hazy: 2-30 Cloudy: 80-750 Sunny: 10,000-25,000
Through the front glass (Given luminance is measured against the sky, the mean of the three measurements (centrally, left and right))	Hazy: 2,000-3,000 Cloudy: 30,000-40,000 Sunny: $-100,000 >$	

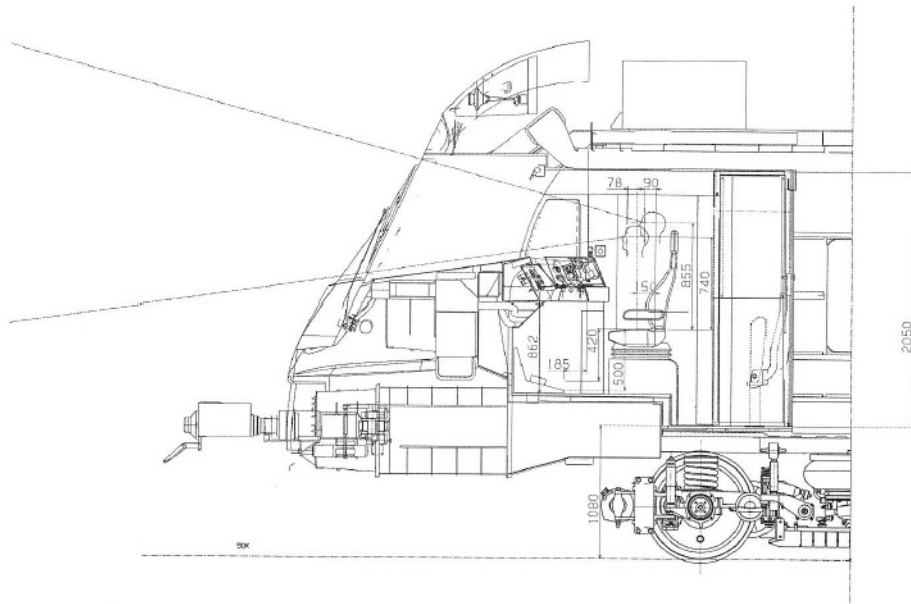

Figure 18. Illustration of a cab of the commuter trains studies.

10 SVENSK POPULÄRVETENSKAPLIG SAMMANFATTNING

Den teoretiska bakgrunden som presenteras i denna avhandling består av datorarbete (bildskärmsarbete) som ett stationärt visuellt krävande närarbete och därmed är mer mottaglig för yttre miljöfaktorer såsom felaktig ljusdesign. I arbetsmiljöer som inkluderar bildskärmsarbete finns, utöver skärmens, ljuskällor från t.ex. takarmatur, pendelarmatur, skrivbordsarmatur och solens inflöde från fönster. Dessa ljusflöden kan antingen direkt eller indirekt (reflexer från skärm eller andra omgivande ytor) påverka den visuella kvaliteten på synobjektet.

Vi tillbringar mer och mer tid åt att arbeta med datorer. Bildskärmsarbete innebär krävande visuella arbetsuppgifter där båda ögonen måste riktas (konvergera) mot samma fixationspunkt (eftersom de flesta människor använder båda ögonen samtidigt).

När vi utför bildskärmsarbete saknar vårt centrala synfält tre-dimensionella (3D) synintryck på grund av att skärmen är platt. Detta leder till minskade kontrollfunktioner för det binokulära seendets (samsynens) koordination och kan därför resultera i ögonrelaterade symptom. När den visuella miljön är försämrad såsom vid direkt- och indirekt bländning läggs ytterligare belastning på det visuella systemet. I dessa situationer kan den binokulära kontrollen reduceras ytterligare och därför även påverka vårt beteende vid läsning. Dessa faktorer kommer sannolikt att bidra till synrelaterade symptom i samband med bildskärmsarbete, s.k. Computer Vision Syndrom (CVS).

Tre områden av kliniska studier ingår i avhandlingen. Denna forskning syftade till att utforska det teoretiska sambandet mellan: (1) vikten av centralt placerade 3D-funktioner i synfältet med avseende på ackommodations- och vergens mekanismer; (2) påverkan av en reducerad synbarhet på stimuli och/eller en försämrad bild på näthinnan på kvaliteten på binokulära seendet som en indikator på visuell trötthet; (3) påverkan av en reducerad synbarhet på stimuli och/eller försämrad bild på näthinnan på ögonrörelser vid läsning.

Studie I klargjorde för vikten av att det i centrala synfältet finns synintryck (stimuli för fixation) som är i 3D för att bidra till att öka konvergensfunktionens noggrannhet och stabilitet i fixation. Studie II utvärderade påverkan av synförsvårande bländning på den binokulära kontrollen. Resultaten visade att den binokulära kontrollen ökade i instabilitet med svårighetsgraden av bländning i samband med bildskärmsarbete och det fanns en mer uttalad effekt när ljusförhållanden skapade direkt bländning. Studie III beskrev påverkan av synförsvårande bländning på ögonrörelser vid läsning. Resultaten påvisade att ögonrörelser vid läsning på skärm påverkades negativt i ljusförhållanden som inducerade direkt- och indirekt bländning. Studie IV utvärderade tröskelvärdet för luminans vid direkt bländning genom att använda inducerad instabilitet i fixation (indikator för visuell trötthet, studie II) som ett riktmärke. Utöver att en bedömning gjordes på effekten på binokulära seendets kontroll utvärderades även en subjektiv respons när det gäller ögonsymtom. Direkt bländning

av 2000 cd/m² konstaterades att minska instabiliteten i binokulär koordination med en ökad grad av ögonsmärta.

Sammanfattningsvis bidrar bildskärmsarbete till en försämring av den binokulära koordinationen på grund av en försvagad kontroll av konvergensen. Arbete vid bildskärm ger i allmänhet en två-dimensionell (2D) visuell miljö. Resultatet från denna forskning talar för en mer uttalad relation mellan reducerat synintryck för 3D stimuli centralt placerade i synfältet med förhöjd exponering av synförsvårande bländning i samband med bildskärmsarbete. Direkt bländning verkar försämra kvaliteten på näthinnans bild i så hög grad att det kan identifieras som det mest uttalade olämpliga ljusförhållandet. Utvärdering av tröskelvärde för luminans gällande direkt bländning tyder på att det är rimligt att rekommendera att ljusflöde mot ögonen ska vara betydligt lägre än 2000 cd/m². Denna forskning har tagit ett steg i riktning mot att motivera vikten av att följa rekommendationerna för ljusdesign i arbetsmiljöer som inkluderar bildskärmsarbete.

Resultaten grundat på studierna i denna avhandling kan ligga till grund för att ytterligare visa på att det finns stora fördelar med att beakta synergonomi i arbetsmiljön. Då synkraven är förhöjda vid datorarbete bör den individuella synstatusen utvärderas i större utsträckning i samband med optometrisk undersökning.