

From the DEPARTMENT OF DENTAL MEDICINE
Karolinska Institutet, Stockholm, Sweden

HEALTH IMPLICATIONS OF DENTAL AMALGAM

Aron Naimi-Akbar



**Karolinska
Institutet**

Stockholm 2013

All previously published papers were reproduced with permission from the publisher.
Cover illustration painted by Clara Naimi-Akbar.
Published by Karolinska Institutet. Printed by Larserics Digital Print AB, Sundbyberg

© Aron Naimi-Akbar, 2013
ISBN 978-91-7549-066-3

*BÉRALDE: When you put on the cap and gown of a doctor, all that will come of itself,
and you will afterwards be much more clever than you care to be.*

.ABSTRACT

Dental amalgam is one of the most widely used, but also the most controversial of dental restorative materials. Since its introduction during the first half of the 19th century, concerns have been raised about health hazards related to the toxicity of a major component of amalgam, mercury. This has been a particularly contentious issue in Sweden, where amalgam use was discontinued in 2009, on environmental grounds.

Two aspects of particular concern are the release of mercury vapour from dental amalgam fillings in patients and occupational exposure to mercury in clinical dental personnel handling amalgam. The aims of this thesis were twofold: to follow the progress of patients with health problems which they attribute to dental amalgam fillings and secondly, to investigate whether the offspring of female dental personnel handling amalgam were at increased risk of adverse effects from potential exposure to mercury vapour *in utero*.

In Study I we examined symptoms, perceived health changes over time and health-related quality of life (HRQoL) among applicants for subsidized replacement of amalgam fillings. We used a questionnaire to collect data. The results showed that the applicants had a wide range of symptoms and that their HRQoL was much poorer than in the general population in Sweden.

Study II documented the use of social security benefits by applicants for replacement of amalgam fillings. The data were retrieved from Swedish registers for the years 1994 to 2006. The cohort of dental filling replacement patients had a significantly higher number of days on sick leave and disability pension than the general population. These differences increased during follow-up. In the replacement cohort, the highest number of sick-leave days was recorded in the year they applied for subsidized replacement of fillings. While sick leave decreased following the year of application, the number of days on disability pension increased and peaked at the end of follow-up.

Study III compared cognitive function among the sons of female dentists and dental nurses with that of sons of female physicians and assistant nurses. The aim was to determine whether the sons of female dentists and dental nurses had been harmed by the mothers' potential occupational exposure to mercury while handling amalgam. The cognitive test scores were for a test undergone by all young men in Sweden when they were conscripted for military service. Data were retrieved from national registers. Sons of dental workers had cognitive function test results similar to, or higher than their comparison cohorts.

Study IV investigated the risk of early mortality among the sons of female dental personnel. Using data from the national registers, neonatal, infant and childhood mortality rates were compared for the sons of dental and of non-dental health care personnel. The sons of female dentists were compared with those of female physicians and the sons of female dental nurses with those of female assistant nurses. Analysis of data from the 1960's disclosed a statistically significantly higher risk of neonatal

mortality among the sons of dental nurses than the sons of assistant nurses. In the subsequent two decades, this difference no longer reached statistical significance and a trend test demonstrated a consistent decrease in risk over the three decades (1960's, 1970's and 1980's).

The following conclusions may be drawn from the results of the studies:

- A) In patients who attribute their poor health to their amalgam fillings, replacement of the fillings does not seem to lead to marked improvement in quality of life; HRQoL is well below the national average. Nor does filling replacement facilitate a return to workforce participation: in the years following filling replacement, these patients remain largely reliant on sick-leave or disability benefits. While the decreasing use of amalgam in recent years and its discontinuation from 2009 should lead to fewer and fewer people claiming amalgam-related ill-health, failure of current measures to improve the HRQoL in these patients and facilitate their return to the workforce is not only unsatisfactory for the individual patients, but also unacceptable to society. Further research is warranted to find ways of improving the status of these patients.
- B) There is no evidence that exposure to mercury vapour *in utero* has an adverse effect on the cognitive function of the offspring of female dental professionals who handled amalgam during pregnancy. For the decade of highest use of amalgam, higher rates of neonatal mortality, but not of infant or childhood mortality, were disclosed among the offspring of female dental professionals.
- C) In Sweden, amalgam use decreased during the 1970's and 1980's and was finally discontinued in 2009. Thus the potential hazards of mercury exposure from amalgam fillings in patients and occupational exposure in dental personnel handling amalgam, no longer apply in Sweden. Nevertheless, these findings on the health implications of dental amalgam, reliably supported by the Swedish national registers, provide an important frame of reference for countries with high caries activity, where amalgam use remains high.

LIST OF PUBLICATIONS

- I. **Naimi-Akbar A**, Svedberg P, Alexanderson K, Carlstedt-Duke B, Ekstrand J, Englund GS. Health-related quality of life and symptoms in patients with experiences of health problems related to dental restorative materials. *Community Dent Oral Epidemiol.* 2012 Sep 10. [Epub ahead of print]
- II. **Naimi-Akbar A**, Svedberg P, Alexanderson K, Ekstrand J, Sandborgh-Englund G. Reliance on social security benefits by Swedish patients with ill-health attributed to dental fillings: a register-based cohort study. *BMC Public Health.* 2012 Aug 30;12:713.
- III. **Naimi-Akbar A**, Sandborgh Englund G, Ekbom A, Ekstrand J, Montgomery S. Cognitive function among sons of women who worked in dentistry. *Scand J Work Environ Health.* 2012 Nov 1;38(6):546-52
- IV. **Naimi-Akbar A**, Sandborgh Englund G, Ekbom A, Ekstrand J, Näsman P, Montgomery S. Mortality among sons of female dental personnel - a national cohort study. Submitted

CONTENTS

| | | |
|-------|---|----|
| 1 | Introduction..... | 1 |
| 1.1 | Dental amalgam..... | 1 |
| 1.2 | Amalgam wars..... | 2 |
| 1.3 | Human exposure..... | 3 |
| 1.3.1 | Exposure levels..... | 4 |
| 1.3.2 | Exposure from dental restorations..... | 4 |
| 1.3.3 | Occupational exposure..... | 5 |
| 1.3.4 | Foetal exposure..... | 5 |
| 1.4 | Health effects..... | 5 |
| 1.4.1 | Health effects and amalgam restorations..... | 6 |
| 1.4.2 | Health effects and occupational exposure..... | 6 |
| 1.4.3 | Health effects on offspring and occupational exposure..... | 7 |
| 1.5 | Filling replacement as part of medical rehabilitation..... | 7 |
| 1.6 | Social security benefits..... | 8 |
| 1.6.1 | Aims..... | 9 |
| 2 | Methods..... | 10 |
| 2.1 | data sources..... | 10 |
| 2.1.1 | Applications for subsidized filling replacement (Study I and II)..... | 10 |
| 2.1.2 | Questionnaire (Study I)..... | 11 |
| 2.1.3 | Total Population Register (Study II, IV)..... | 13 |
| 2.1.4 | The Longitudinal integration database for health insurance and labour market studies - LISA (Study II)..... | 13 |
| 2.1.5 | Population and Housing Censuses (Study III and IV)..... | 14 |
| 2.1.6 | Multi-Generation Register (Study III and IV)..... | 14 |
| 2.1.7 | The Conscript Register (Study III)..... | 15 |
| 2.1.8 | The Patient Register (Study IV)..... | 15 |
| 2.2 | Study designs..... | 16 |
| 2.3 | Statistical methods..... | 18 |
| 2.3.1 | The Chi ² -test..... | 18 |
| 2.3.2 | Student's t-test..... | 18 |
| 2.3.3 | Generalized Estimating Equations (GEE)..... | 18 |
| 2.3.4 | Linear regression..... | 19 |
| 2.3.5 | Cox proportional hazards model..... | 19 |
| 3 | Results..... | 21 |
| 3.1 | Study I..... | 21 |
| 3.1.1 | General symptoms..... | 21 |
| 3.1.2 | Oral Symptoms..... | 21 |
| 3.1.3 | Health Related Quality of Life..... | 21 |
| 3.1.4 | Health changes over time..... | 23 |
| 3.2 | Study II..... | 24 |
| 3.2.1 | Study III..... | 27 |
| 3.2.2 | Study IV..... | 28 |
| 4 | Discussion..... | 30 |
| 4.1 | Main findings..... | 30 |

| | | |
|-------|--|----|
| 4.1.1 | Study I | 30 |
| 4.1.2 | Study II | 30 |
| 4.1.3 | Study III | 31 |
| 4.1.4 | Study IV | 32 |
| 4.2 | Methodological considerations | 32 |
| 4.2.1 | Study designs | 32 |
| 4.2.2 | Internal validity | 33 |
| 4.2.3 | Bias | 34 |
| 4.2.4 | Confounding | 34 |
| 4.2.5 | Effect modification | 35 |
| 4.2.6 | External validity | 36 |
| 4.2.7 | Causal inference | 36 |
| 4.3 | General discussion and Future research | 41 |
| 5 | Conclusions | 42 |
| 6 | Svensk sammanfattning | 43 |
| | Acknowledgements | 45 |
| | References | 47 |

LIST OF ABBREVIATIONS

| | |
|-------|---|
| CI | Confidence Interval |
| DAG | Directed Acyclic Graph |
| GEE | Generalized Estimating Equations |
| Hg | Mercury |
| HR | Hazard Ratio |
| HRQoL | Health Related Quality of Life |
| LISA | The Longitudinal integration database for health insurance and labour market studies |
| MCS | SF-12 mental health summary measure |
| PCS | SF-12 physical health summary measure |
| SF-12 | Short Form survey with 12 questions |

1 INTRODUCTION

Dental amalgam is acknowledged as a useful restorative material, but there have long been concerns about the potential health hazards associated with the release of mercury vapour. Extensive research has failed to disclose any strong association between mercury release from amalgam fillings and poor health.

Despite the lack of evidence, some people associate poor health with amalgam restorations and undergo replacement with alternative restorative materials. Several studies have shown improvement in self-rated health following replacement of amalgam fillings, but there is no conclusive evidence that this is attributable to the decrease in mercury exposure. Little is known about the impact of their health impairment, or subsequent filling replacement, on such aspects of the patient's life as work force participation.

Another important issue is the potential risk to dental personnel of exposure to mercury vapour when working with dental amalgam. Mercury can pass through the placental barrier in pregnant women, potentially constituting a health hazard to the offspring of female dental personnel handling amalgam while pregnant. There are, however, few studies of the long-term effects on the offspring of exposure to mercury *in utero*.

1.1 DENTAL AMALGAM

Long before the Christian era, different materials were used to restore decayed teeth (1). One of the most important, as well as one of the most controversial restorative materials is dental amalgam, first introduced during the first half of the 19th century (1-3).

Dental amalgam is produced by mixing liquid mercury with a powder of different metals (an alloy). Mercury can amalgamate with most metals, but the commonly used dental amalgam contains one part liquid mercury and one part alloy. About 70% of the alloy is silver, about 25% tin with smaller amounts of copper and zinc. This composition has varied over the years. The mixed amalgam is pliable and easy to insert and model in the prepared tooth cavity; on hardening it forms a durable, albeit unaesthetic, restoration.

1.2 AMALGAM WARS

Dental amalgam has been used to restore teeth for almost 200 years. Despite its favourable properties, its use has been highly controversial because of concerns about its potential effects on health. These controversies are often referred to as amalgam wars.

The first amalgam war began during the first half of the 19th century, when amalgam was a relatively new dental restorative material. In 1833, two brothers named Crawcour moved from France to New York and set up a dental practice. The Crawcour brothers are famous for their production and promotion of a filling material comprising a mixture of crushed silver coins and liquid mercury (1-3). They called their new material “royal mineral succedaneum”. They actually started production in France before they moved to the US and started to market their product in New York (1-3). Compared to gold, which was the main filling material at the time, the advantages were that it was much cheaper and quicker to insert (1-3).

It is alleged that the Crawcour brothers had only rudimentary knowledge and skills in dentistry and their incompetence actually caused their patients considerable harm (3). The association between the Crawcour brothers’ incompetence and their use of amalgam is thought to have contributed to concerns about dental amalgam from the start. The treatment of syphilis with a mercury-containing ointment, which had devastating effects on the patient’s health, is also thought to have contributed to scepticism towards amalgam fillings (1-3).

American dentists were divided in their opinions as to whether mercury- containing amalgam was an acceptable restorative material, or if it was so harmful that it should never be used (1-3). In the 1840’s, the American Society of Dental Surgeons banned the use of amalgam by its members. It became a requirement for continued membership of the association that members sign a pledge not to use dental amalgam (1-3). This period, when amalgam was banned, is referred to as the first amalgam war. In 1855, as the use of amalgam had continued, the ban against members who used dental amalgam was lifted (1-3).

In 1926 Alfred Stock, a professor of chemistry at the Kaiser Wilhelm Institute in Berlin published a scientific paper “Die Gefährlichkeit des Quecksilberdampfes” (The hazard of mercury vapour). He had observed what he suspected to be mercury poisoning in his laboratory where he had been working for 25 years. In this paper Stock also addressed the topic of dental amalgam, concluding that it should no longer be used in dentistry. Subsequently, Alfred Stock continued his research into the hazards of mercury and dental amalgam and published 50 papers on this topic. “Die Gefährlichkeit des Quecksilberdampfes” led to heated debate in Germany about the safety and use of dental amalgam (1-3). This dispute was the second amalgam war. Once again the dispute was highly polarised. The second amalgam war continued in Germany, without consensus, until the start of the real war in 1939.

The third amalgam war began in Sweden in the late 1970's. In 1978 an interest organization was founded for people who considered that they were the victims of dental malpractice (Tandvårdsskadeförbundet) (4). For the following two decades, debate over dental amalgam continued. Today, in what might be the end of the third amalgam war, the intensity of the debate has faded, together with the use of dental amalgam. In 2009, the use of dental amalgam was discontinued in Sweden, on environmental grounds.

Dental amalgam is still in use in most other parts of the world. However, a treaty to prevent emission of mercury was just recently agreed to at a UN meeting on the topic (5, 6). While the use of dental amalgam has not been banned, it will gradually be reduced: thus in years to come, there should be a global decrease in amalgam use.

1.3 HUMAN EXPOSURE

Mercury vapour is the gas that vaporizes from liquid mercury. Human exposure to metallic mercury mainly occurs through inhalation of elemental mercury vapour (7). Mercury vapour is lipid soluble and easily crosses cell membranes. It is absorbed by the lungs into the blood stream and dissolved in the red blood cells and plasma (7-9). About 80% of the inhaled mercury vapour is absorbed in the lungs. It is distributed by the blood to the tissues of the body (7-9) (Figure 1). In the cells, the elemental mercury can be oxidized into mercuric mercury through the hydrogen peroxide catalase pathway (7, 8): oxidation can occur in the red blood cells as well as in the brain and probably most other tissues (7, 8). If oxidized in the brain, the mercuric ion is trapped there for a long time, as it does not cross the blood-brain barrier as readily as elemental mercury (7, 8).

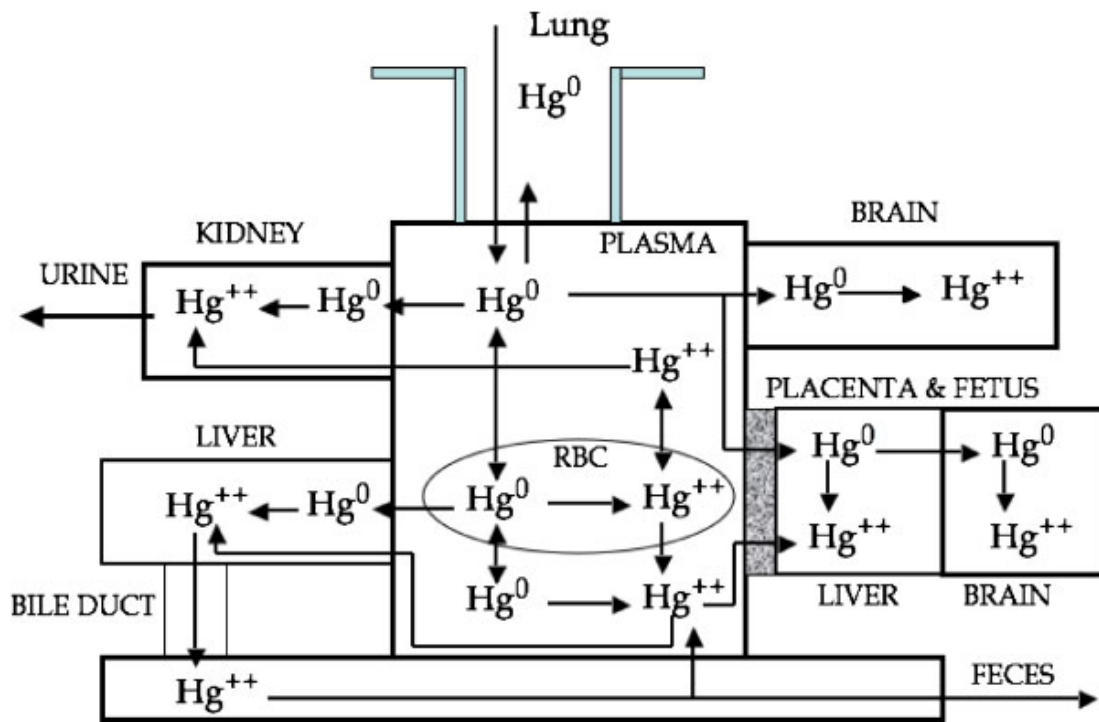

Figure 1. The disposition and metabolism of inhaled mercury vapour by Clarkson et al (9). Reproduced with permission of *John Wiley and Sons*.

1.3.1 Exposure levels

The two main sources of exposure to inhaled mercury vapour are through occupational exposure to mercury vapour and exposure from dental amalgam fillings. There are several biological markers of elemental mercury exposure, such as mercury concentrations in blood, faeces, hair or urine. Urinary mercury concentration has been used mainly to monitor chronic mercury exposure. Although different measures of urinary mercury concentrations are used in the literature, in the present thesis mercury concentrations in urine are expressed as $\mu\text{g Hg/l}$.

1.3.2 Exposure from dental restorations

Patients with amalgam fillings are chronically exposed to low doses of elemental mercury through its release from the amalgam fillings (7, 8). There is a correlation between exposure levels and the number of fillings, but it is also influenced by such habits as excessive gum chewing (10-14). After removal of amalgam fillings, mercury concentrations in blood plasma decrease (15, 16). In an adult population with amalgam restorations, average urinary mercury levels are reported to be about 1 to 4 $\mu\text{g/l}$ (17-19). In extreme cases, urinary levels as high as about 50 $\mu\text{g/l}$ have been reported (20).

1.3.3 Occupational exposure

Industrial exposure to mercury vapour occurs in the production of caustic soda, thermometers, batteries and small scale gold mining (8, 21). Occupational exposure to elemental mercury vapour can also occur in clinical dental practice, in association with the preparation of dental amalgam for restorations (8).

However, dental personnel working with amalgam were previously exposed to higher levels of elemental mercury vapour than they are today. Not only has the amount of amalgam used varied over time, but also the handling of the material. Up until the 1970's, there was little awareness of the need for caution with respect to mercury exposure in clinical dentistry in Sweden. The amalgam was prepared by mixing liquid mercury and alloy in a mortar in the open air and then expressing the excess liquid mercury through a chamois or cloth to achieve the right texture. The risk of mercury spillage was high and mercury exposure was increased. In the 1970's, semi-automatic mixing devices were gradually introduced, followed in the 1980's by pre-measured sealed capsules for amalgam preparation. These more hygienic ways of handling amalgam reduced the risk of mercury spillage (22). Thus from the 1960's, improved methods of preparing amalgam, together with the decrease in amalgam use as alternative filling materials were introduced, resulted in a gradual decrease in exposure among dental personnel.

The average urinary mercury levels reported in dental personnel in the 1960's were approximately 40-50 µg/l (23, 24). This decreased in the 1970's to 10-20 µg/l urine (24) and in the 1980's to below 10 µg/l (24, 25). Swedish studies from the 1980's and 1990's reported only slightly higher mercury concentrations in dental personnel than in control groups from the general population (25, 26). In Sweden, where amalgam restorations are no longer allowed, the exposure levels among dental personnel are now likely to be similar to the population average.

1.3.4 Foetal exposure

Foetal mercury exposure is a potential health hazard for the offspring of female dental personnel, who may be exposed to mercury due to their daily handling of amalgam. Foetal exposure is mainly through cord blood (27); the magnitude of mercury concentration in maternal plasma is reflected by the magnitude of the foetal mercury concentration in blood plasma (27-29).

1.4 HEALTH EFFECTS

Although extreme exposure levels among patients with amalgam fillings have been reported, the present project is concerned with the health implications of two different

types of exposure to dental amalgam: occupational exposure among dental personnel and exposure from amalgam fillings in patients.

The mechanisms of the adverse effects of mercury are complex and not completely clear, but the major mechanism of biological activity is thought to be binding of the mercuric ion to thiol or sulphhydryl groups (7). Through this binding it is thought to have several potential effects in human tissues, such as inactivation of various enzymes or transport processes or altering cell membrane permeability, oxidative stress or impairment of synaptic transmission (7).

1.4.1 Health effects and amalgam restorations

A number of patients suffering ill health attribute their symptoms to mercury release from their dental amalgam fillings (30, 31). These patients experience a wide variety of symptoms and impaired health related quality of life (19, 30). However, a causal relationship between these symptoms and mercury release has yet to be disclosed: studies have shown that there is no increased risk for health problems among patients with dental amalgam fillings and no association between mercury levels in patients and symptoms (31-34). Alternative explanations for these patients' symptoms are that they are primarily psychological in origin, or heavily influenced by negative life events (33, 35).

In the New England Children Amalgam trial children were randomly assigned for either amalgam fillings or other filling materials not containing mercury; no negative effects were disclosed among the children in the amalgam group (36-39).

Several randomized trials as well as observational studies have examined the effect of filling replacement on self-perceived health among patients attributing their health issues to dental amalgam. Improvement in self-perceived health has been reported after replacement of amalgam fillings (19, 40-42). However, there is a high risk for measurement bias in these studies, because the patients have not been blinded to their treatment. One study found improvement in the group undergoing amalgam replacement and similar improvement in a control group which did not undergo filling replacement, but participated in a health promotion program (19). Alternative explanations are that this improvement is just a part of the natural course of health changes in these patients, that it is a placebo effect or that it is the effect of regression to the mean.

1.4.2 Health effects and occupational exposure

Acute exposure to high levels of elemental mercury vapour might cause damage to the respiratory and cardiovascular systems, with increased blood pressure and heart rate (7). There may also be negative gastrointestinal effects, with abdominal pain and oral

mucositis, fatigue, fever and tremors (7) and even to death. Our knowledge of the symptoms of acute toxicity is based primarily on documentation of industrial accidents involving workers handling metallic mercury.

With respect to chronic exposure to elemental mercury, adverse neurobehavioural effects have been reported in several occupations, at levels similar to those present in dentistry in the 1960's and 1970's (21, 43-45). Most results concern impaired motor function among the workers. There seems to be a dose-dependent relationship, where the level of exposure is reflected by the magnitude of adverse effects, but it is unclear at what exposure level adverse effects begin to occur (43, 44). Toxic effects on renal function have also been seen in workers with chronic mercury exposure (7).

Studies of dental personnel report slightly impaired cognitive function and self-reported symptoms such as concentration problems as well as motor problems (18, 43, 46, 47). One Danish nationwide register-based cohort study on renal, neurological and Parkinson's disease covering the years 1964 to 2006, found no association between occupation in dentistry and any of the outcomes (48).

1.4.3 Health effects on offspring and occupational exposure

Animal studies have found negative effects on neurodevelopment in offspring after exposure to mercury vapour (49-51). Epidemiological studies of negative effects in offspring from occupational exposure to mercury vapour provide limited, contradictory evidence (52-58). Research has focused primarily on fertility and pregnancy outcomes. A study from 1987 found an association between mercury exposure in female dental personnel and reproductive failures (57). The study was criticized for methodological flaws (59). One Swedish study on pregnancy outcomes in dental personnel found no increased risk for adverse pregnancy outcomes such as perinatal death, congenital malformations, stillbirths and spontaneous abortions (53).

A study investigating the association between the mother's dental amalgam fillings and early cognitive development in offspring found no such association (60).

1.5 FILLING REPLACEMENT AS PART OF MEDICAL REHABILITATION

Under the Swedish National Dental Insurance Scheme, dental treatment may be available as part of the general medical system. This aspect of the Dental Insurance Scheme is the responsibility of the county authorities. In 1999, reform of the National Dental Insurance Scheme included subsidized replacement of dental restorations, primarily for patients with a long history of symptoms allegedly due to the adverse effect of dental restorative materials. The criteria according to the Act and the Ordinance on state dental care are that the patients should have undergone a thorough medical investigation and that the dental restoration replacement constitutes a part of an

overall medical treatment plan for the patient. The overall treatment plan is the responsibility of a specialist physician in a field related to the patient's symptoms (61). As shown in Figure 2, in recent years, there has been a dramatic decrease in the number of patients receiving subsidized treatment.

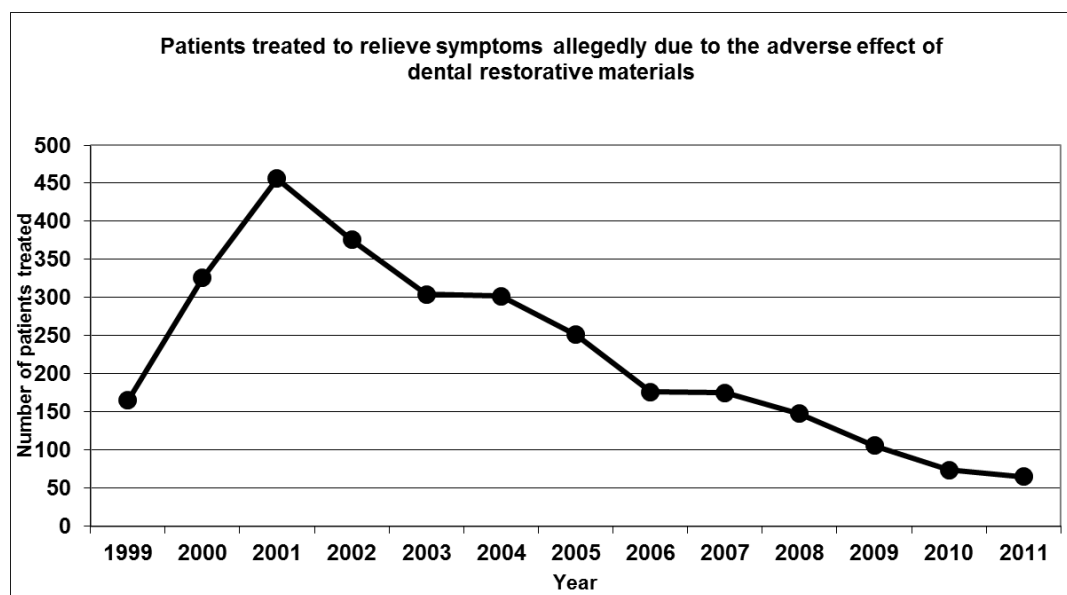

Figure 2. Number of patients undergoing filling replacement as part of medical rehabilitation in Sweden for the years 1999 to 2011.

1.6 SOCIAL SECURITY BENEFITS

There are few studies examining sick leave among patients attributing ill-health to their amalgam fillings. It was reported that compared to a matched comparison population, patients with health complaints attributed to dental amalgam had a significantly increased probability of being sick-listed (35). Apart from this study, to our knowledge there are no longitudinal studies on sick leave and use of the social insurance benefits by these patients. There is no specific diagnosis for sick-listing someone presenting with health problems allegedly due to adverse reactions to dental amalgam fillings.

All residents of Sweden are covered by the National Social Insurance Scheme. All adult residents with income from work or unemployment benefits are entitled to sickness benefits covering up to 80% of lost income when unable to work due to sickness, disorders or injury. The first sick-leave day is a qualifying day with no benefits. After the 7th sick-leave day, further leave requires a sickness certificate, issued by a physician. The employer provides sick pay for the first 14 days of sick-leave; thereafter, *i.e.* from day 15, the sickness benefits are provided by the Social Insurance Agency.

Individuals with a medically confirmed disease or injury which permanently restricts their work capacity can be granted a disability pension, covering at least 65% of lost income. The general old-age retirement age is 65 years but can be accessed earlier.

1.6.1 Aims

1.6.1.1 *General aim*

The general aim of this epidemiological research project was twofold: to gain a deeper understanding of patients with health problems purportedly related to dental amalgam fillings and secondly to investigate whether the offspring of female dental personnel were adversely affected by their mothers' occupational exposure to mercury.

1.6.1.2 *Specific aims*

The specific aims of this research project were:

- To investigate symptoms, perceived health changes over time, and health-related quality of life (HRQoL) in subjects with subjective health impairment, allegedly due to amalgam fillings (Study I).
- To analyse reliance on different forms of social security benefits by patients who attribute their poor health to dental amalgam fillings (Study II).
- To investigate whether the offspring of Swedish female dental personnel have impaired cognitive function. During the study period mercury levels in dental personnel were higher than are typical in Sweden today (Study III).
- To investigate whether the sons of female Swedish dental personnel exhibit an increased childhood mortality risk (Study IV).

2 METHODS

2.1 DATA SOURCES

The data for this research project were obtained by two different methods: from registers kept by Swedish authorities and by the use of a questionnaire, supplying data reported by the patients. The population-based registers provide an effective source of reliable research data in large populations. Since 1947, all residents in Sweden have been issued with a unique personal identity number: this is the key variable that enables linkage between registers in epidemiological research (62). Questionnaires have other advantages, as they have the potential to disclose information that is not stored in registers, but which may be of specific relevance to the aim of the study.

2.1.1 Applications for subsidized filling replacement (Study I and II)

Applications for dental filling replacement as part of medical rehabilitation are made to the Swedish county authorities. To compile the study population, we contacted the dental units at the county councils. The study population comprised 546 applicants for subsidized dental restoration replacement between 1999 and 2005, i.e. all applicants in seven out of the 21 Swedish counties, covering about 39% of the Swedish population (Figure 3).

In 2008, background information on the applicants was collected from the seven county councils. It included data on sex and date of birth, the number and date of the subsidized dental restoration replacement applications, as well as the resultant decision about whether the application was fully or partially approved, or rejected.

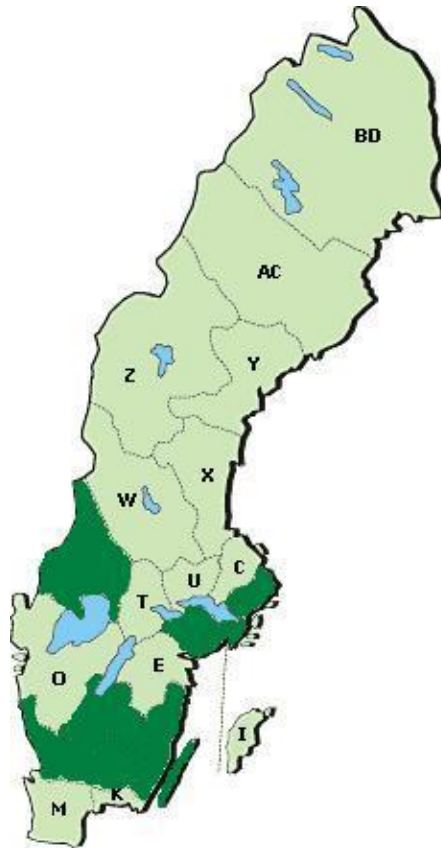

Figure 3. Map showing the parts of Sweden covered in the study of applicants for filling replacement. The seven counties are Stockholm, Södermanland, Jönköping Kronoberg, Kalmar, Halland and Värmland.

2.1.2 Questionnaire (Study I)

A questionnaire was constructed to include items about restoration removal, self-rated health over time, symptoms, and Health Related Quality of Life (HRQoL). The questionnaire was sent to applicants for subsidized filling replacement.

2.1.2.1 SF-12 -Health Related Quality of Life

HRQoL is a useful instrument for estimating the impact of ill-health on a patient's quality of life. We used the Swedish version of SF-12 "SF-12 Health Survey: Swedish User Handbook" to obtain data on HRQoL on the filling replacement cohort (63). The SF-12 instrument includes twelve questions about physical and mental wellbeing and functioning and provides two summary scale scores, one for mental (MCS) and one for physical (PCS) health.

2.1.2.2 General symptoms

The participants were asked to indicate whether they had any of 21 general symptoms (Table 1). The absence of a response to a particular symptom in the list was recorded as a negative response.

2.1.2.3 Oral symptoms

Twelve oral symptoms were listed in the questionnaire (Table 1). The absence of a response to a particular symptom in the list was recorded as a negative response.

Table 1. General and oral symptoms

| General symptoms | Oral symptoms |
|--|---------------------------------|
| Joint and muscle pain | Dry mouth |
| Sleep problems | Fatigue in the jaws |
| Fatigue | Pain in the jaws |
| General weakness | Tenderness from the teeth |
| Impaired short term memory | Bleeding gums |
| Concentration problems | Burning mouth |
| Low tolerance to environmental factors | Taste disturbances |
| Visual disturbances | Metallic taste |
| Diarrhea/ constipation | Sore mouth |
| Increased sensitivity to electric or magnetic fields | Toothache |
| General skin problems | Ulcers/sores in the oral mucosa |
| Respiratory problems | Increased salivation |
| Dizziness | |
| Irritability | |
| Heart palpitations and/or irregular cardiac rhythm | |
| Depression | |
| Tinnitus | |
| Anxiety | |
| Headache | |
| Infection susceptibility | |
| Nausea | |

2.1.2.4 *Health over time*

On the topic “How has your health been in recent years?” the subjects were requested to rate their health for each year between 1996 and 2008, on an ascending, six-point scale (64) (very poor, poor, moderate, good, very good, or excellent). For descriptive statistics and statistical analyses, the scores were aggregated into three categories, by combining the lowest two scores as poor health, the middle two as moderate, and the highest two as good health.

2.1.3 Total Population Register (Study II, IV)

The total population register is an amalgamation of several other national registers. It is maintained by Statistics Sweden and contains individual data, including personal identity number, sex, age, place of birth, date of death, date of immigration and other basic demographic information.

For Study II, a comparison population representative of the general population was selected by random sampling from The Total Population Register of all residents of Sweden, to match, at a ratio of 3:1, the population of applicants for filling replacement with respect to sex and year of birth.

In Study IV, mortality data were obtained from the total population register, as date of death. Data were retrieved for the sons of female dental personnel and their comparison cohorts, comprising the sons of female health care personnel. Mortality was categorised into three periods of life as follows.

- 1) Neonatal mortality - death of the child within the first 28 days after birth. Due to confidentiality constraints, the data included year and month of birth, but not the day. The date of birth was therefore set to the first of the month for everyone. As this could exclude up to half of the neonatal deaths, we extended the time period by 15 days to 43 days after birth, as an approximation of the first 28 days.
- 2) Infant mortality - death of the child within the first year of birth.
- 3) Childhood mortality - death within the first 16 years of birth.

2.1.4 The Longitudinal integration database for health insurance and labour market studies - LISA (Study II)

LISA is a database maintained by Statistics Sweden. It was constructed to facilitate data retrieval for research, and contains data from several national registers, to provide annually registered longitudinal data related to the individual’s life situation, relation to the labour market, work and health (65).

Through linkage to (LISA), using the Swedish personal identification number (62), individual information was retrieved for both the filling replacement and the general population cohorts, for each of the years 1994 to 2006. The data included educational level, other socio-demographic factors, as well as different sources of income, social welfare benefits and the number of days on unemployment benefits, sick leave, and disability pension. The outcome measures were the annual number of days on disability pension, sick leave, and unemployment benefits, respectively. Income data were retrieved as the total income in Swedish kronor for each subject each year. Receiving social welfare benefits or the old-age pension during a year was categorized as yes or no.

2.1.5 Population and Housing Censuses (Study III and IV)

Mothers of the study subjects in Studies III and IV were identified using Swedish population and housing censuses.

Between the years 1960 and 1990, regular population and housing censuses were conducted in Sweden every fifth year, covering such information as demographics, employment and education. The censuses are kept by Statistics Sweden.

The occupations of women were identified using the Population and Housing Censuses (1960, 1970, 1980, 1985 and 1990), which include information about a person's occupation at the time of the Census. Women identified as dentists or dental nurses for at least two consecutive census years were defined as being at greater risk, if pregnant during this period, of having an offspring exposed to mercury *in utero*. For the comparison cohorts, the censuses were also used to identify women working as physicians and assistant nurses.

2.1.6 Multi-Generation Register (Study III and IV)

The sons of female dental personnel as well as sons of female health care personnel were identified using the Multi-Generation Register.

This Register includes all people, born in 1932 or later, who have been registered in Sweden at any time since 1961. The register provides linkage between first-degree relatives (66). Several subjects could be the sons of the same mother. The boys in the exposed cohorts were individually matched with boys born during the same year with a mother of the same age, who was working as a physician or an assistant nurse. The matching ratio was planned as 1:5; where this was not achievable, all available subjects were selected. The offspring of dentists were matched with the offspring of physicians and those of dental nurses with those of assistant nurses.

2.1.7 The Conscript Register (Study III)

Universal military service applied in Sweden between 1901 and 2010; i.e. all men were conscripted into military service. Since the 1940's, conscripts have undergone a cognitive function examination on enlistment. Cognitive ability was assessed in order to allot the conscript to an appropriate deployment. Practically all able bodied young men in Sweden took the tests; the data for each individual are held in the Conscript Register.

Our main outcome measures in Study III were cognitive tests used and registered in the Conscript Register until 1997 (referred to as Enlistment Battery 67 and Enlistment Battery 80), which were undertaken by conscripts born between 1960 and 1978. The examination consisted of four tests, which we used separately as our outcome measures. Two tests assess linguistic understanding and the ability to use oral and written language. The first test, Linguistic Understanding 1, evaluated the conscript's ability to interpret and follow written instructions. The second test, Linguistic Understanding 2, examined the ability to identify synonyms. The third test, Spatial Recognition, examined the ability to visualize manipulation of objects mentally and to recognize objects in different positions. The fourth test, Technical Comprehension, consisted of problems which could be solved by applying knowledge of mechanics and basic physics (67-70). Each test consisted of 40 units. The scores were transformed into a value on a normalized standard scale of nine units, with an average of 5 (67). We used the standardized scores ranging from 1 to 9 for each test.

2.1.8 The Patient Register (Study IV)

In Study IV, the Patient Register was used to obtain information on the diagnoses preceding deaths among the offspring of female dental personnel.

Since 1964 The National Board of Health and Welfare has maintained data on hospital discharges in the Swedish National Inpatient Register (71). Initially comprising data from only six Swedish counties, the register was gradually expanded, reaching full national coverage in 1987. The positive predictive value of diagnoses in the register is about 0.85 - 0.95; in general it is higher for more severe disease and lower for less severe disease diagnoses.

2.2 STUDY DESIGNS

All four studies in the project are cohort studies, the most common design for epidemiological studies. The main features are that cohorts are defined according to an exposure and then followed over time, and outcomes are measured. Study designs can typically be divided into observational and experimental studies. Epidemiological research is strongly associated with observational research, but it may be stated that a randomized clinical trial represents a special type of cohort study in which the exposure is randomly assigned. A summary of the study designs used are presented in Table 2.

Table 2. Study designs.

| | Study I | Study II | Study III | Study IV |
|-----------------------|--|---|--|---|
| Study design | Retrospective cohort, cross-sectional | Retrospective cohort with prospective data. longitudinal measurements | Retrospective cohort with prospective data | Retrospective cohort with prospective data |
| Data sources | Applications for filling replacement, questionnaire | Applications for filling replacement, Total Population Register, LISA | Population and Housing Censuses (1960, 1970, 1980, 1985 and 1990), Multigeneration Register, Conscript Register | Population and Housing Censuses (1960, 1970, 1980, 1985 and 1990), Multi generation Register, Total Population Register, Patient Register |
| Study population | Applicants for filling replacement n – 515 | Applicants for filling replacement <65 years. General population sample Replacement cohort: n - 505 General population cohort: n - 1496 | Sons of female dental personnel and sons of health care personnel born between 1960 and 1978 Dentist cohort: n - 365 Dental nurse cohort: n - 3181 Physician cohort: n - 378 Assistant nurse cohort: n - 12667 | Sons of female dental personnel and sons of health care personnel born between 1960 and 1990 Dentist cohort: n - 1690 Dental nurse cohort: n - 10420 Physician cohort: n - 2683 Assistant nurse cohort: n - 44908 |
| Exposure | Filling replacement due to health problems | Application for filling replacement | Mother's occupation | Mother's occupation |
| Outcomes | General symptoms, oral symptoms, HRQoL, health changes | Disability pension, sick leave, unemployment benefits, income, early old-age pension, social welfare benefits | Cognitive test scores | Neonatal mortality, infant mortality, childhood mortality |
| Potential confounders | Disability pension | Educational attainment, age, sex, birth country | Father's educational level, mother's age at delivery, older siblings, decade | Father's educational level, mother's age at delivery, older siblings, decade |
| Statistical tests | Chi2-test, Student's t-test | Generalized Estimating Equations (GEE) | Linear regression | Cox proportional hazards model |

2.3 STATISTICAL METHODS

2.3.1 The Chi²-test

The Chi²-test is commonly applied to compare proportional differences of independent observations between groups. The Chi²-test was used for inter-group comparison of such characteristics as age and sex distribution. (Studies I-III). In Study I the Chi²-test was also used to compare the prevalence of symptoms and the proportions of subjects in the exposure groups reporting improved health. The level of significance was set at 0.05.

2.3.2 Student's t-test

Student's t-test is commonly used to analyse normally distributed mean values. This was used in Study I. The HRQoL (MCS and PCS) mean scores in the exposure groups (replacement group/non-replacement group) were compared using a two-sided t-test for independent samples under the heteroscedastic assumption. The mean scores were also compared with the means of the general population, using a two-sided one sample t-test. To compare the SF-12 scores with that of the general population, a stratified analysis was used, excluding study participants receiving disability pensions.

2.3.3 Generalized Estimating Equations (GEE)

Generalized Estimating Equations (GEE) is an appropriate tool for analysing longitudinal data when the outcome measure is not continuous and normally distributed (72). It also offers the opportunity to control for potential confounding factors. For the years 1994 to 2006, the annual number of days on disability pension, sickness benefits, and unemployment benefits and income were modelled as a series of repeated measures. The assumption of the Poisson distribution of the dependent variable was used, with an autoregressive correlation structure and the log link function. The model included cohort (replacement/general population), year modelled as a series of dichotomised dummy variables, and an interaction term between year and cohort. Analyses were adjusted for educational level, country of birth, and sex as dichotomous dummy variables, and age as a continuous variable.

Early old-age pension and social welfare benefits (yes or no) were also analysed with GEE, but assumed the binomial distribution and the logit link function.

The analyses were performed within the replacement cohort in relation to the application year, that is, the year of application (T0), and included the previous five years as well as the subsequent five years. Differences in days on disability pension and sickness benefits between those whose applications had been approved or rejected, respectively, were analysed using GEE. We used the assumption of the Poisson

distribution of the dependent variable, with an autoregressive correlation structure and the log link function. The model included application approval (approval/rejection), year modelled as a series of dichotomised dummy variables and an interaction term between year and application approval. Analyses were controlled for educational level, country of birth and sex as dichotomous dummy variables, and age as a continuous variable.

Subjects were included in the analyses up to the year of their 65th birthday. Subjects who emigrated were not included following the year of emigration.

IBM SPSS Statistics 20 and STATA version 12 was used for statistical analyses. P-values less than 0.05 were considered as statistically significant.

2.3.4 Linear regression

The standard application of regression models in epidemiology is to estimate the effect of a risk factor on an outcome, while controlling for potential confounding factors. We used linear regression to estimate associations between continuous, normally distributed means and our exposures.

In Study III, the mean scores for the four components of Enlistment Battery 67 and Enlistment Battery 80 (Linguistic Understanding 1, Linguistic Understanding 2, Spatial Recognition and Technical Comprehension) were compared between the cohorts, using linear regression, adjusted for father's educational level, mother's age at birth, older siblings and decade of birth, modelled as series of dichotomous categorical variables. An approximation of potential maternal exposure prior to birth was based on the number of years elapsing between the first census in which the dentist or dental nurse was registered in the profession and the time of delivery. This was categorized as higher (over five years) or lower exposure (up to five years). In the cohorts comprising the sons of dental personnel, more than one could have the same mother. As independence of the observations is assumed, additional analyses were limited to the first born to individual mothers during the study period.

PASW Statistics 18 software was used for statistical analyses with linear regression. P-values less than 0.05 and confidence intervals not including 0 were considered as statistically significant.

2.3.5 Cox proportional hazards model

The Cox proportional hazards model is one of the most commonly applied models in medical time-to-event studies. In Study IV, Cox proportional hazards models were applied to calculate hazard ratios for the outcomes, with separate models for mortality

categorized into three periods of life and separate models for each of the three calendar periods (1960's, 1970's and 1980's). Exposure to mercury was high in the 1960's and then declined in the 1970's and 1980's (22-25). Dental nurses were compared with assistant nurses and dentists were compared with physicians. Analyses were adjusted for maternal age and the father's educational level, both modelled as a series of dichotomous dummy variables. As the same mother could have had several children, the standard errors (and confidence intervals) were corrected by clustering the subjects by their mothers.

To test for a possible trend in mortality risk over the three decades of the study period, the interaction of decade by cohort (dental worker or other health worker) was assessed in a single model to identify effect modification, after adjustment for the main effects.

The proportional hazards assumption was tested using Schoenfeld residuals. This confirmed that the proportional hazards assumption was not violated in any of the regression models.

Statistical tests were performed using STATA 12. Confidence intervals not including 1 were considered as statistically significant.

3 RESULTS

3.1 STUDY I

The questionnaire was sent to 515 of the total of 546 applicants for subsidized restoration replacement: 31 had been lost due to death or emigration. There were 280 respondents to the questionnaire (54.4%). The response rate was significantly higher for women than for men and lowest in the youngest age group. The application approval rate was lower among non-responders than responders. The age and sex distributions were similar in the replacement and the non-replacement groups.

3.1.1 General symptoms

The most common symptoms reported were joint and muscle pain, disturbed sleep, fatigue, and a sensation of weakness, with prevalence all well above 50%. Joint and muscle pain, susceptibility to infection, low tolerance to environmental factors and sensitivity to electric or magnetic fields were all significantly more common among those who stated that they had undergone replacement of fillings because of health issues than among those who had not had fillings replaced.

3.1.2 Oral Symptoms

About a third of the patients reported dry mouth, jaw fatigue, pain in the jaws and tenderness of the teeth. These were the most common oral symptoms. There was no statistically significant difference in oral symptoms between the replacement and the non-replacement groups. Metallic taste and increased salivation were more common among men than women. Bleeding gums were more common in the youngest age group and dry mouth more common in the oldest age group.

3.1.3 Health Related Quality of Life

There were no significant differences between men and women, younger and older age groups, the replacement and non-replacement groups or application approval/rejection with respect to MCS or PCS. Compared with the general population in Sweden, the subjects had significantly lower HRQoL in terms of both MCS and PCS (63) (Figures 4 A and B).

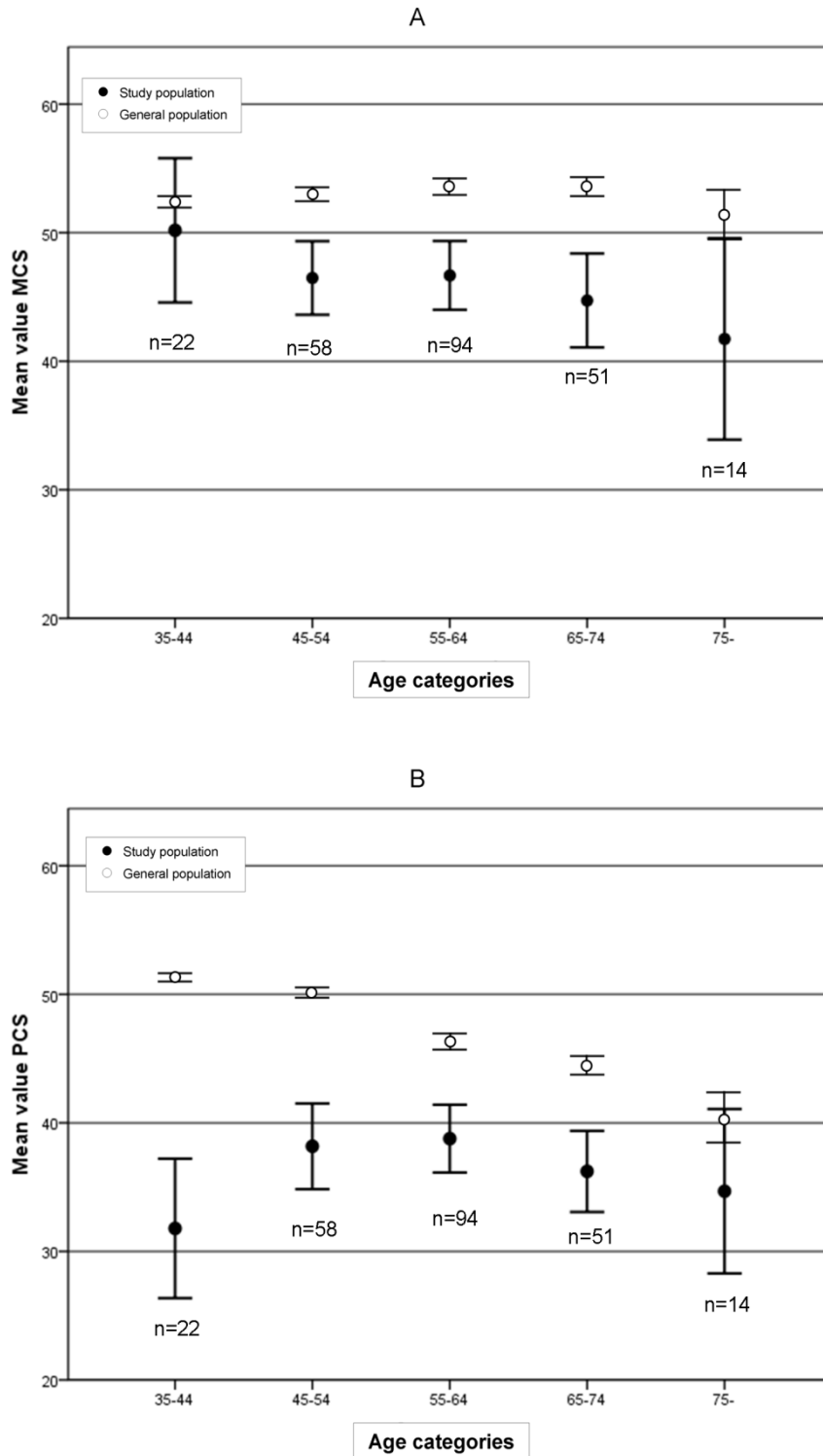

Figure 4. (A) MCS. SF-12 mental health: mean score with 95% CI in the study population and in the general population in Sweden. (B) PCS. SF-12 physical health: mean score with 95% CI in the study population and in the general population in Sweden. The age categories were adjusted to the categories used in the reference study (63). The number of subjects in the study population in each age category is shown in the figure.

3.1.4 Health changes over time

The distribution of subjects in the three health categories (poor, moderate, and good) is presented in Figure 5. In the replacement group a distinct pattern could be seen in the proportion reporting poor health. It was most common in the year of application when almost two-thirds of the replacement group reported poor health. Thereafter self-rated health ratings improved in the 1-3 years after the application for subsidized restoration replacement.

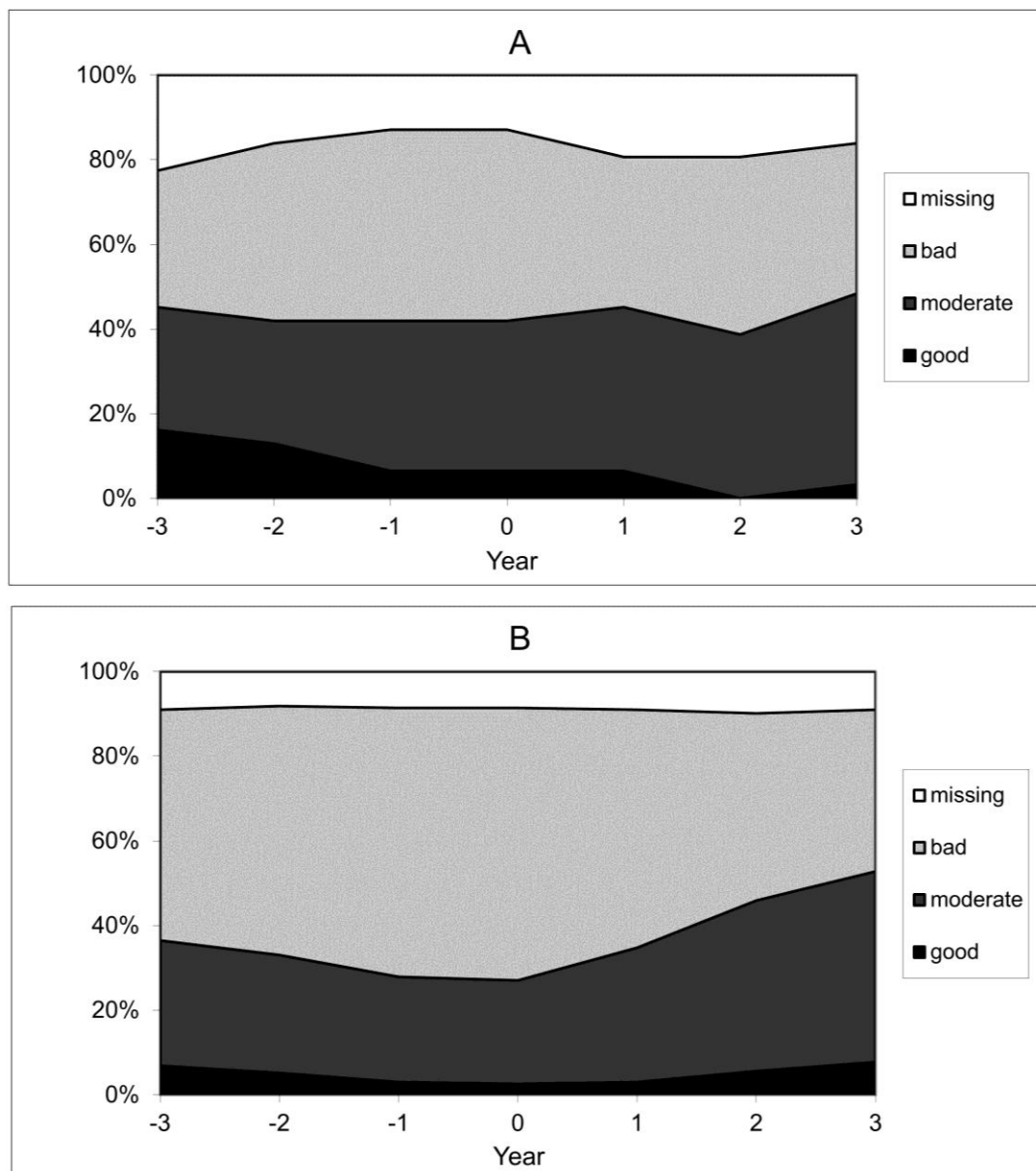

Figure 5. Distribution of subjects according to health status: year 0 represents the year of application for subsidized restoration replacement. (A) Non replacement group (n=31), (B) Replacement group (n=233). In years 2 and 3, the changes in proportions of subjects reporting poor, moderate and good health differed significantly between the exposure groups.

3.2 STUDY II

Of the 546 patients who applied for subsidized filling replacement, 505 were aged 65 years or younger in the year of application. They were included in the study of sick-leave and disability pension. The cohort from the general population comprised 1496 subjects. In the replacement cohort, subsidised filling replacement was approved for 322 subjects (63.8 %).

The pattern of changes in number of sick-leave days showed an increasing difference between the two cohorts until 2002. It then began to decrease until the last year of follow-up (2006) (Figure 6). There was a significant association between being in the replacement cohort and an increase in sick-leave days. The longitudinal changes in days on sick leave differed between the two cohorts.

In the longitudinal comparison of disability pension, there was a steeper increase in the replacement cohort (Figure 6). The difference between the replacement cohort and the general population cohort in days on unemployment benefits was highest early in the follow-up and decreased over time (Figure 6).

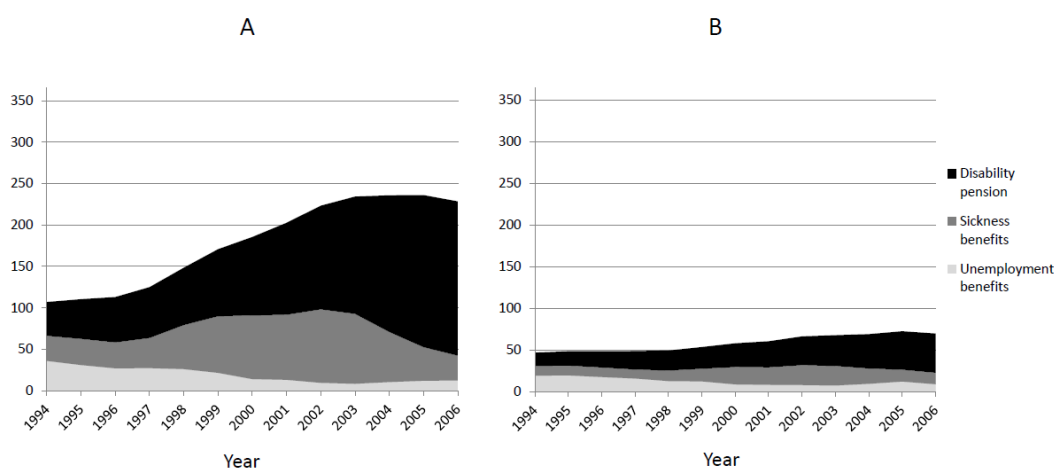

Figure 6. Mean number of days on sick leave, disability pension, and unemployment benefits between 1994 and 2006, (A) in the replacement cohort and (B) in the general population cohort.

After the year of application (T_0), the number of days on sick-leave decreased dramatically in the replacement cohort. However, the total number of days absent from work, on a disability pension and/or sick leave did not change, because the days on disability pension continued to increase rapidly in the same years (Figure 7).

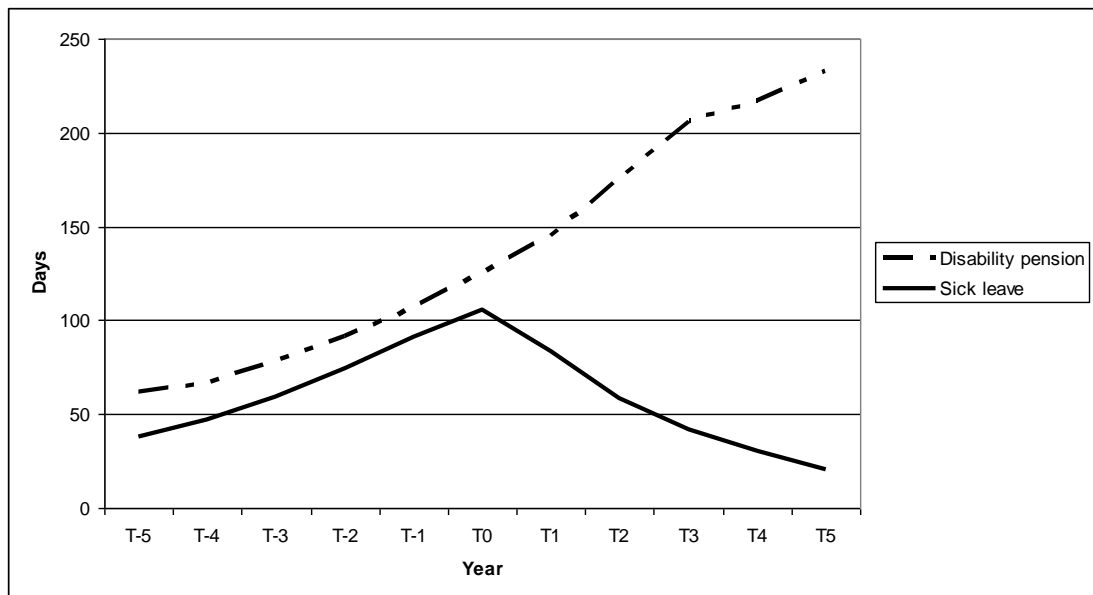

Figure 7. Annual sick-leave days and disability pension in the replacement cohort five years before and after the year of application for replacement of dental fillings. Averages derived from regression analyses with GEE.

The differences in income between the two cohorts increased between 1994 and 2006 and the changes over time were statistically significant (Figure 8). The proportions taking early old-age pension (before age 65) were significantly higher in the replacement cohort at baseline but there was no increased difference over time (Figure 8). Similarly, the proportion depending on social welfare support was significantly higher in the replacement cohort at baseline, but there was a no statistically significant difference in the pattern of change over time (Figure 8).

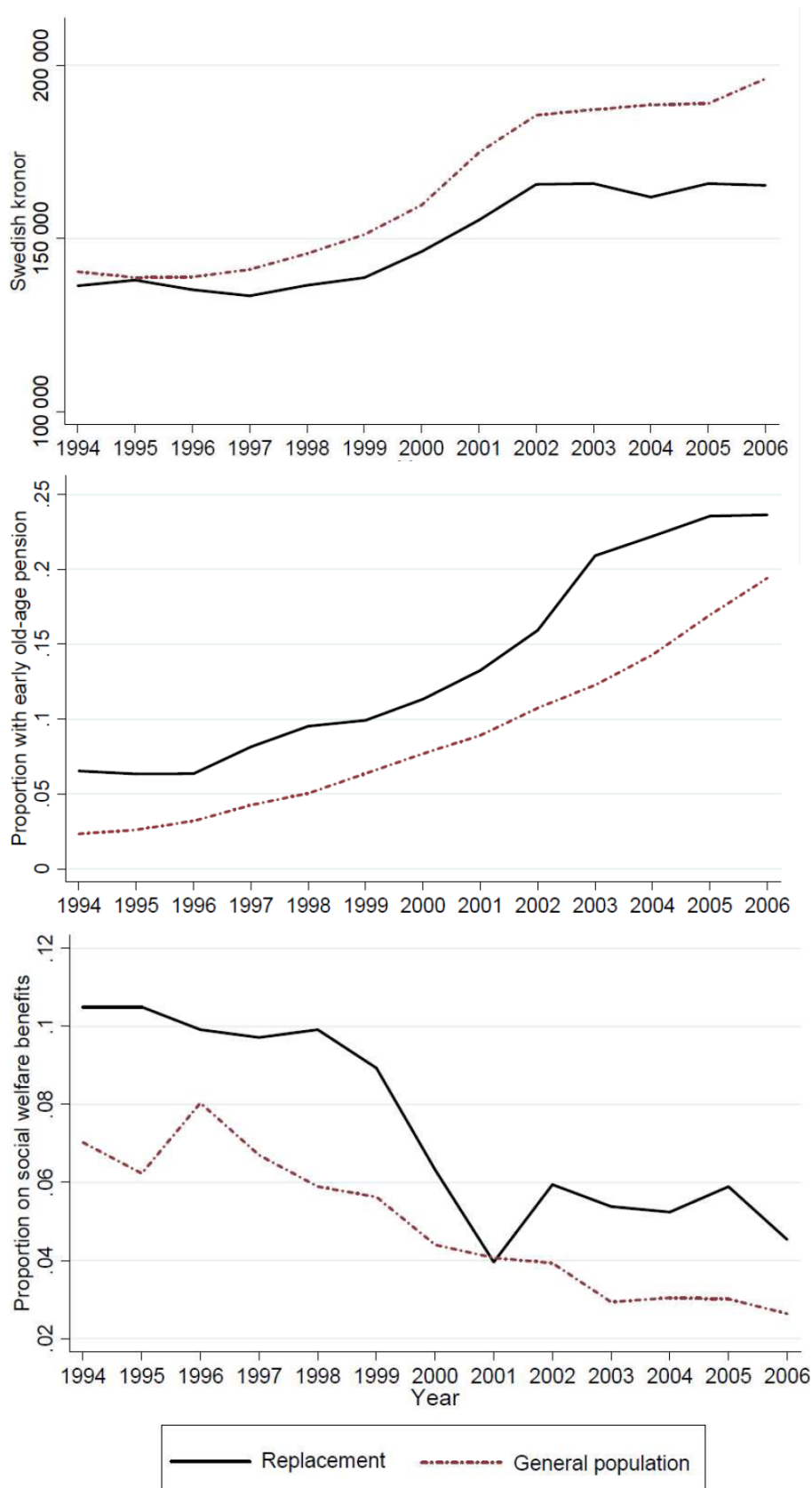

Figure 8. Annual income in Swedish kronor (SEK), early old-age pension, social welfare support in the replacement cohort and the general population cohort in 1994 - 2006. Predicted measures from regression analyses with GEE.

3.2.1 Study III

The dentist cohort comprised 365 sons born between 1960 and 1978 to female dentists; the dental nurse cohort comprised 3181 sons, the physician cohort 378 sons and the assistant nurse cohort 12667 sons.

For all four cognitive tests, the dentist cohort had slightly lower scores than the physician cohort, but none of the differences was statistically significant. The dental nurse cohort had significantly higher scores than the assistant nurse cohort; the results were almost unaltered after adjustment for father's educational level, mother's age at time of birth, presence of older siblings and decade of birth. The differences between the dentist and physician cohorts were not statistically significant after adjustment. The distribution of test scores (Linguistic Understanding 1, Linguistic Understanding 2, Spatial Recognition and Technical Comprehension) are presented in Figures 9 and 10.

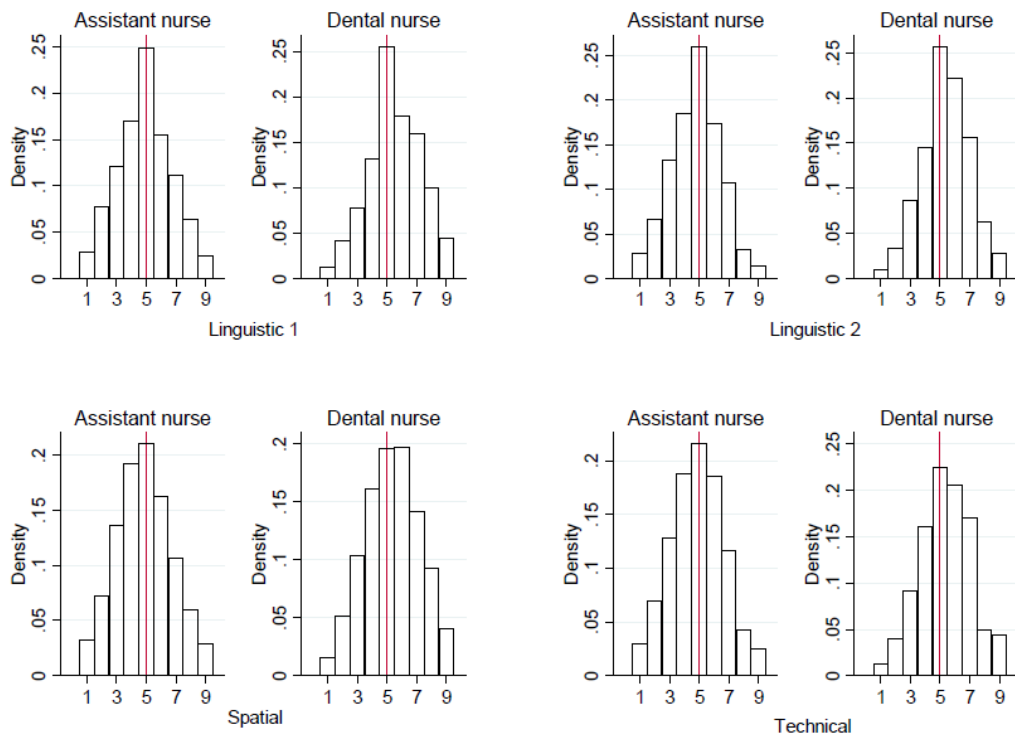

Figure 9. The distribution of test scores in the four cognitive tests for the assistant nurse cohort and the dental nurse cohort. The average scores were clearly slightly higher in the dental nurse cohort.

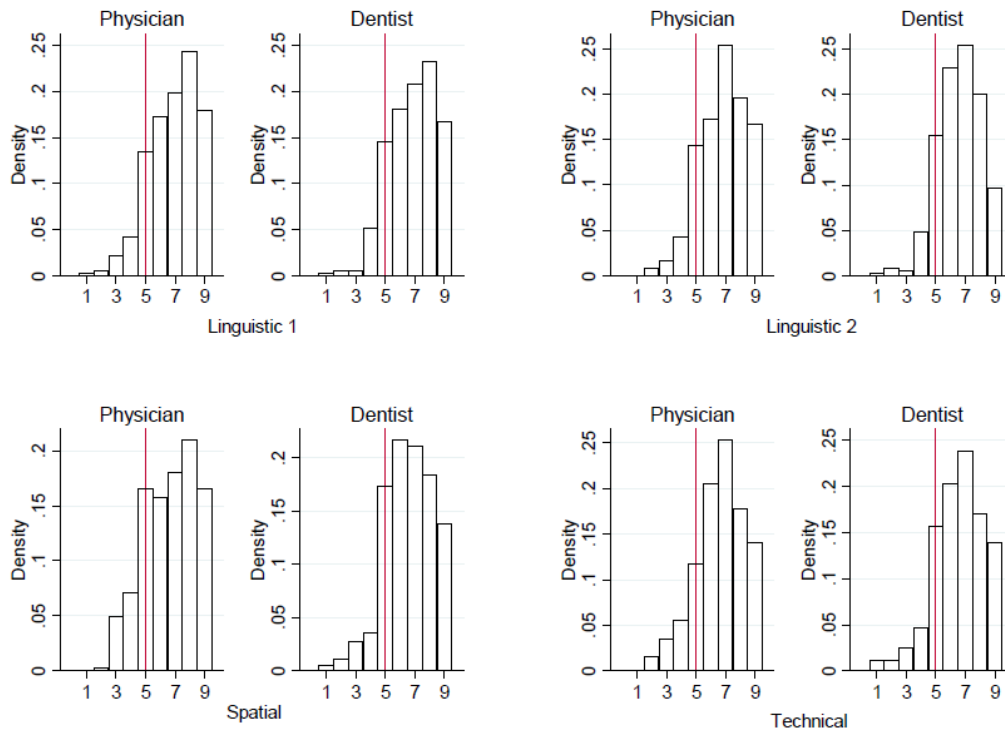

Figure 10. The distribution of test scores on the four cognitive tests for the physician cohort and the dentist cohort. The majority of the scores are to the right of 5, the standardized average of the entire population.

3.2.2 Study IV

In both the dental nurse cohort and the assistant nurse cohort the highest hazard rates were found in the 1960's and then decreased in the 1970's and 1980's (Figure 11). Comparison of the cohorts showed a significantly increased risk among sons of dental nurses in the 1960's, HR: 1.83 (95% CI; 1.04 - 3.22). There was effect modification by decade on the HR, that is, the HR decreased significantly in later decades. The interaction between dental nurse cohort and decade was statistically significant, HR: 0.63 (95% CI; 0.44 - 0.90).

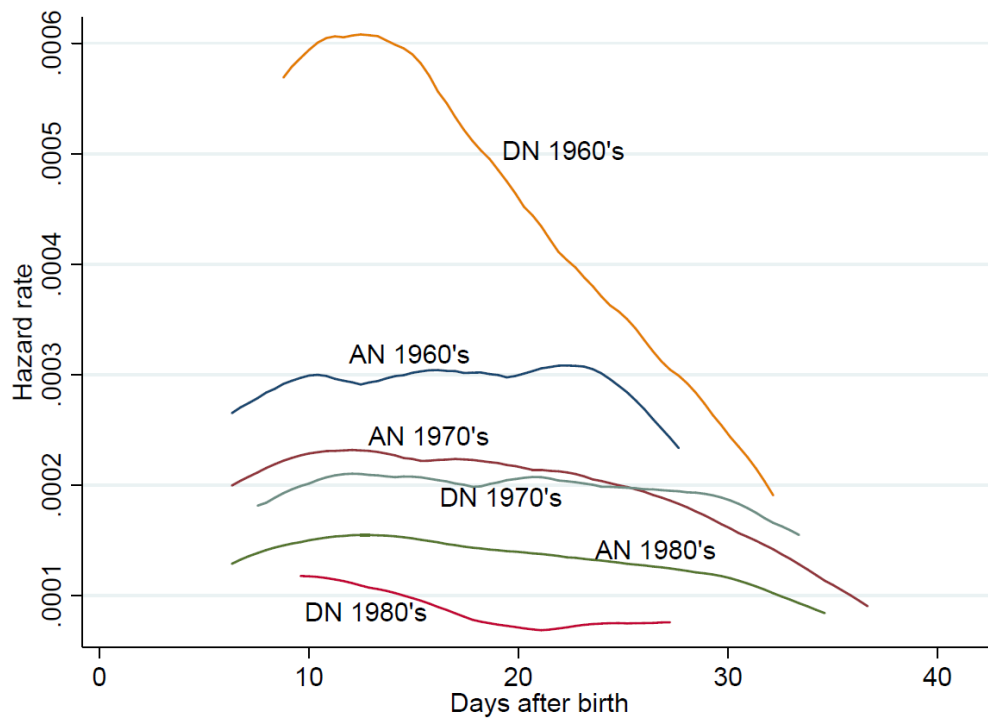

Figure 11. Neonatal hazard rates by decade and cohort, dental nurse (DN) cohort and assistant nurse cohort (AN).

For comparison of neonatal, infant and childhood mortality, the dentist and physician cohorts were underpowered; hence it was not possible to determine differences between the cohorts.

4 DISCUSSION

4.1 MAIN FINDINGS

In this section the findings are discussed in the context of existing knowledge.

4.1.1 Study I

The pattern of symptoms reported by the study subjects is similar to that of several other studies (40, 41, 73, 74). Thus while the present study does not provide new insights, it corroborates the findings of previous studies. In contrast to other studies (40, 41, 73, 74), the intensity of symptoms was not measured in the present study.

The reduction in metallic taste was not unexpected among those who underwent replacement of amalgam fillings, as the restorative materials used for replacement were usually non-metallic. Similar results have been reported previously (41, 75). There was a trend towards increased prevalence of toothache among those who replaced fillings: this might be attributable to untoward sequelae of the operative procedures necessary to remove the restorations, such as pulpal trauma, which may lead to postoperative pulpitis and pulpal necrosis.

In the present study, HRQoL scores were obtained several years after the application for dental restoration replacement. One finding in the present study was that PCS scores were considerably lower than in the previous trial by Melchart et al. (19), and far lower than in the Swedish general population. This highlights the high vulnerability of the patient group.

Although the improvement in self-rated health over time observed in the replacement group may be questioned, the results are in accordance with those of other studies (19, 41, 42, 76). Other contributing factors which should be considered after dental restoration replacement are the placebo effect and a natural reduction in symptoms over time (77, 78).

4.1.2 Study II

One study reported that patients with health complaints attributed to dental amalgam had a significantly increased probability of being sick-listed compared to a matched comparison population (35). The findings are in accordance with ours but longitudinal changes in sick-listing were not reported (35). The rapid transition from sick leave to a disability pension following filling replacement is consistent with the results of a Swedish study of long-term sickness absentees who were referred for multidisciplinary medical assessment by the National Social Insurance Agency (79). The same pattern emerges in the present studies: neither multidisciplinary medical assessment nor dental filling replacement improves the likelihood of a return to work, but seems to accelerate

the path towards disability pension. Our results corroborate the difficulties associated with helping patients on long-term sick leave to resume workforce participation.

Several risk factors are known to be associated with disability pension (80), such as self-assessed poor health. As shown in Study I, the applicants for filling replacement perceived themselves to be in poor health, hence they were at increased risk of a disability pension (81-83).

4.1.3 Study III

This study compared cognitive function in cohorts potentially exposed to mercury *in utero* through the mother's occupation as a dental professional, with comparison cohorts of subjects whose mothers did not work in dentistry. Potentially harmful mercury levels, with median urinary levels of approximately 20 to 50µg/l, were common in dental personnel in the 1960's and 1970's (24, 70).

Besides clinical dentistry, there are other occupations with potential exposure to elemental mercury, such as the chloralkali industries (electrolysis of sodium chloride solution) and cinnabar mining (7). Adverse effects on neurological function, such as impaired motor skills and reduced cognitive function, have been found among workers in these occupations. Adverse neurological effects in children, due to exposure associated with small-scale gold mining, have been reported at a median urinary mercury level of 10.05µg/l (21). There seems to be a dose-dependent relationship, where the level of exposure is reflected by the magnitude of adverse effects, but it is unclear at what exposure level adverse effects begin to occur (43, 44). Since elemental mercury can pass the placenta, there is a potential hazard to the foetus if the mother's blood mercury levels are increased (22, 27, 28, 84, 85).

Studies of exposure to dental amalgam fillings in children have not disclosed any inverse associations with cognitive function; nor did our study of another potential exposure route; *in utero*, due to maternal employment in dentistry (36-38). Studies examining the effect on the offspring of pregnant rats exposed to mercury vapour found dose-dependent negative behavioral effects in the offspring (50, 51). A study of *in utero* exposure in squirrel monkeys showed similar results with long-term effects in the offspring (86). Yet the results of the present studies show that the sons of dental personnel had cognitive function test results similar to or higher than their comparison cohorts. The sons of dentists had somewhat lower average cognitive function scores than the sons of physicians, but adjustment, particularly for father's education, attenuated or reversed the direction of the differences between the cohorts. This suggests that the variation in cognitive function between the cohorts is largely explained by differences in parental and familial characteristics, rather than occupational maternal exposure in dentistry.

4.1.4 Study IV

There are few epidemiological studies of occupational mercury exposure and the risk to foetal development and reproductive health. One Swedish study on pregnancy outcomes in dental personnel found no increased risk for complications such as perinatal death, congenital malformations, stillbirths and spontaneous abortions (53). The study covered the years 1976 and 1981 to 1986: the results, during the periods of lower exposure to mercury, are consistent with our results for the same time period. A Finnish study of miscarriages in female dental personnel in the 1990's found no consistent evidence of an increased risk (87). However, at the time of the study, exposure levels were assumed to be low. Another study on dental personnel employed in the 1980's showed decreased fecundity associated with poor working hygiene in combination with high levels of mercury use in dental assistants (56). A large Norwegian cohort study found no evidence of adverse pregnancy outcomes in dental personnel between the years 1967 and 2006 (54). The disparity between these results and those of the present study may either be because our findings are due to chance or because the earlier period of that study began later, in 1967. It should be noted that the above-mentioned studies measured different outcomes: malformations, prenatal deaths and stillbirths, whereas the present study investigated mortality after birth. One study from the 1980's showed increased risk for reproductive failures (57), but the findings have been questioned on the grounds of methodological limitations (59).

4.2 METHODOLOGICAL CONSIDERATIONS

This section describes important epidemiological concepts and their relevance to the present research project. Some examples are included, for clarification.

4.2.1 Study designs

In a cohort study people with certain exposures are followed over time and risks of disease are measured and compared between different exposure groups. A cohort study is usually a more effective study design for rare exposures; in contrast a case-control study is usually more effective when there is a rare outcome. A crucial point in a cohort study is that there must be adequate numbers of subjects to allow study of the disease: in the case of a rare disease, a large number of subjects and prolonged follow-up may be required. Thus the cohort study might become very costly and time-consuming. Cohort studies may be classified as prospective or historical/retrospective. In a prospective cohort study, measures are made after the initiation of the study, whereas a historical cohort study measures exposures and events that have happened in the past. The prospective cohort is generally seen as a study of higher quality with less bias, because it is easier to measure correctly an event which is currently happening than to measure something that happened a long time ago. If the measures of the historical cohort are of a high standard, it is a very efficient study design. Such is the case with measures recorded prospectively in registers, as in several of our studies.

In our studies on the offspring of female dental personnel, the aim was to investigate the effect of potential mercury exposure *in utero* because of the mother's occupation. A comparison cohort was required to enable measurement of differences due to the exposure in question. A comparison cohort should match the exposed cohort in every aspect apart from the exposure. In this context, the cohorts are exchangeable, *i.e.* the same results would be expected if the exposure states of the groups were exchanged.

To make the cohorts more comparable with respect to social and material status, comparison cohorts were constructed on the basis of mothers in comparable occupations to the dental professionals: the sons of physicians for comparison with those of dentists and the sons of assistant nurses for comparison with those of dental nurses.

With respect to study design, some potential limitations should be highlighted for Study I. Some contributing factors have been addressed in earlier sections, where we presented the annual number of patients treated with amalgam filling replacement in the whole of Sweden. We had initially planned a prospective cohort study of all new applicants in Sweden. However, there was a dramatic decline in number of patients during the period in which we initiated the study. Moreover, fewer than half of the counties consented to participate; hence only about 20 subjects had been included during our first year of inclusion and the study had to be terminated. A prospective follow-up study would have had much greater potential to disclose factors associated with health improvement among these patients.

As mentioned above, some counties decided not to participate and provide study subjects, because of ethical concerns. Informed consent is an essential ethical aspect in all medical research involving human study subjects. Our approach, which had been approved by the ethical review board, was that we would send the questionnaire, with information about the study, to all eligible participants; return of the questionnaire would be regarded as consent to participate. However, county officials disapproved of this proposal on the grounds that it would intrude on the personal integrity of the patients.

4.2.2 Internal validity

Internal validity is an important factor to be considered in epidemiological research, *i.e.* whether the measurements actually measure what they are intended to measure. A systematic error in measurement (88) might compromise the internal validity of a study. Such flaws are generally classified into selection bias, measurement bias and confounding.

4.2.3 Bias

Selection bias results from the method of recruiting patients to the study and arises if the participants have a different association between the exposure and outcome from those who were eligible to participate but declined. Selection bias may therefore be likely in Study I, in which a large proportion of eligible subjects declined to participate. Measurement bias or information bias, as it is usually referred to, is a systematic error in measurement, usually associated with the exposure. This might also be a considerable issue in Study I, with reference to retrospective measurement of self-rated health. Some uncertainty or error in the measures is likely when subjects are asked to recall the state of their health several years previously. A form of measurement bias, called recall bias, may have been introduced: it might be argued that the subject's memory of their health status some years earlier was influenced by whether he or she had undergone filling replacement. This seems likely in the context of the present study.

The register data, which were recorded prospectively, are less likely to have outcomes that are subject of differential misclassification. That the outcome mortality should be subject to any misclassification seems highly unlikely. The cognitive tests we used as our outcome measures in Study III have been used in other studies to show adverse effects from ionizing radiation (89); thus they are sensitive markers of environmental exposures.

4.2.4 Confounding

Confounding may be described as a blending of effects: analysis of the results of a study may disclose an association between exposure and outcome, but it is actually due to a common, extraneous factor associated with both outcome and exposure (Figure 12). There are three necessary characteristics for a confounding factor (88); 1 – it must be an extraneous risk factor for the disease, 2 – it must be associated with the exposure under study in the source population and 3 – it must not be affected by the exposure or the disease. In particular it may not be an intermediate step in the causal pathway between the exposure and disease.

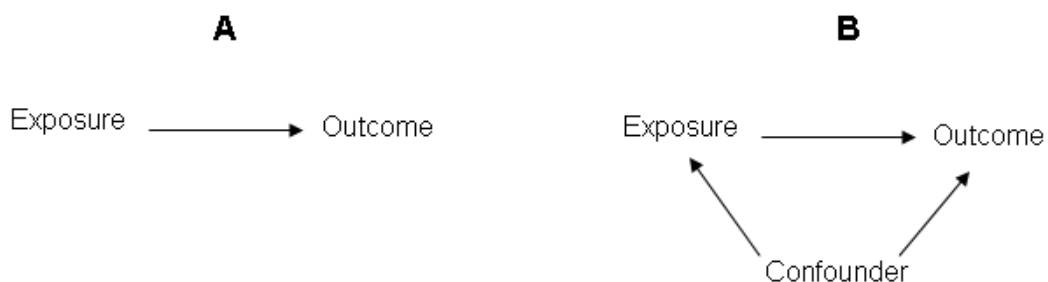

Figure 12 DAG (directed acyclic graph) showing (A) the causal pathway, where the association between exposure and outcome is a true causal relationship and (B) an association between exposure and outcome due to an extraneous factor.

In epidemiological research, the risk of confounding can be managed in several ways. Randomization, restriction, or matching may be applied to the study design. Restriction was applied, for example, in Study III. If it had been assumed that sex would fit the criteria for a confounding factor for the association between potential mercury exposure and cognitive function, the risk of confounding by sex might have been avoided by restricting the study subjects to include only one sex. This study was in fact restricted to male subjects, not, however, in order to avoid confounding, but to ensure adequate numbers of subjects. Very few women enlisted for military service. Had matching been applied instead, one unexposed girl would have been included for every girl in the exposed cohort, and one boy for every exposed boy: the sex distribution would be exactly the same. Thus there cannot be an association between sex and exposure: therefore it does not fit the necessary criteria for a confounder. Matching might be preferable to restriction, as it does not limit generalizability as much. With randomization, all potential confounders, known as well as unknown, should be evenly distributed between exposure groups. However, randomization is only an option in experimental research.

If confounding was not avoided in the study design, there are several means of redressing the issue during data analysis, for example by stratification, or by using regression models. Regression models were applied to control for confounding factors in Studies II-IV.

It is acknowledged that social class might play an important role in epidemiological research. This was particularly evident in the study on cognitive function (Study III) (90). Social class was a potential confounder in the present studies and therefore needed to be controlled for. In Studies II-IV, educational level, one of the most commonly used markers of social class, was applied: it is considered to be an important influence on social standing, facilitating advantageous behaviour and enhancing occupational advancement (88, 90). Educational level is also a stable measure, as it is usually established in early adulthood and then fixed for the rest of a person's life. However, the magnitude of the positive effects of education is not constant over different time periods or between different societies (88).

4.2.5 Effect modification

Another concept in epidemiological research is effect modification, which should be distinguished from confounding. Effect modification is where the association of two factors is altered by a third: this is investigated using statistical interaction testing. It is described as departure from additivity of effects on the chosen outcome scale (88). The emergence of effect modification on a selected outcome scale is noteworthy, as it may

be affect one scale but not another. This was a factor in Study IV, in which the differences in relative risk varied between decades. One assumption made for this statistical interaction to be considered an effect modification is that the effect is not caused by bias. As mentioned previously, it was important to avoid confounding in order to achieve correct results in our studies. Effect modification, however, is in itself an interesting result which should be presented as a finding.

4.2.6 External validity

In order to apply the study findings and to place them in context, assessment of external validity is important *i.e.* assessment of the generalizability of these findings. However, before any attempt is made to generalize the findings, the internal validity must be confirmed.

In Studies I and II, the population from which the subjects were drawn comprised all applicants for subsidized removal and replacement of amalgam fillings over a large region of Sweden: such a large geographical uptake area should contribute to good external validity. However, generalization was complicated by the heterogeneous nature of the group of applicants for removal and replacement of amalgam fillings.

In Studies III and IV the subjects were exclusively male. This complicates generalization. Moreover, as occupational exposure to mercury is no longer an issue in Swedish dentistry, it is unlikely that the results are generalizable to the offspring of today's Swedish female dental personnel. The results might more readily be generalized to the offspring of female dental personnel in countries where amalgam use is similar to that in Sweden during the study period, or perhaps to other occupations with mercury exposure at similar levels to those in Swedish dentistry during the study period.

4.2.7 Causal inference

An association between an exposure and an outcome found in a study needs to be interpreted with caution. It is important to be aware of several possible reasons for the association of an increased risk of an outcome in one exposure group, *e.g.* there may be an actual causal effect of the exposure in question, the effect may be attributable to unknown confounders which were not controlled for, it may be due to bias, or to chance.

4.2.7.1 Study I

Study I disclosed an improvement in health among those who stated that they had undergone replacement of amalgam fillings for health reasons, compared to those who stated that they had not replaced fillings. As mentioned earlier, it is not clear that the positive effect is caused by the reduction in mercury release due to replacement of amalgam. The effect might be attributable to recall bias, as shown in Figure 13. It might also be due to an unknown confounder. An empathic, caring health care provider might be independently associated with both replacement of fillings and health improvement. The direct path from filling replacement to health improvement might include not only a decrease in mercury levels, but also a placebo effect. Because of these uncertainties, the results must be interpreted with caution.

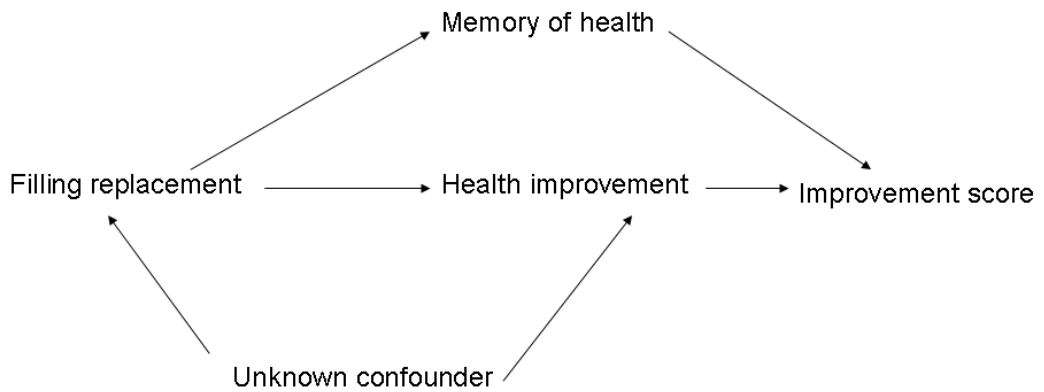

Figure 13. DAG presenting potential pathways to explain the association between filling replacement and improved health found in Study I.

4.2.7.2 Study II

Study II disclosed an association between the replacement cohort and a reduction in work force participation. However, a causal pathway from increased mercury levels due to amalgam fillings to less than full work force participation is not the only possible explanation. A patient's sick-leave might be for other reasons, also associated with amalgam-related health problems (Figure 14). Negative life events might also be a confounding factor in the association between health issues and dental amalgam (35).

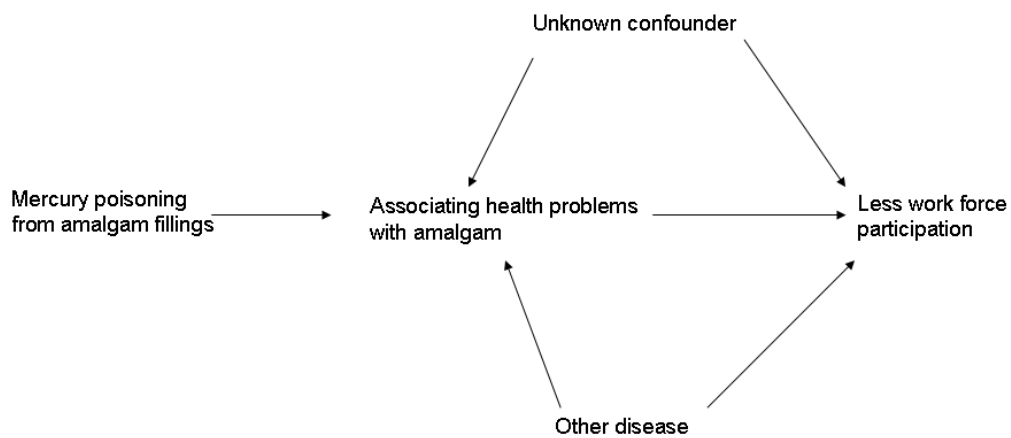

Figure 14. DAG showing potential reasons for association in Study II.

4.2.7.3 Study III

With reference to cognitive function, the only significant differences disclosed in Study III were the higher scores among the sons of female dental nurses compared with those of female assistant nurses. However, it is highly unlikely that mercury exposure *in utero* would enhance cognitive function. Although controlling for parental education reduced the differences, they remained significant. This suggests that social factors, other than those implied by the parents' educational level, might also have an influence (Figure 15). Assistant nurses may be exposed to other harmful, unidentified factors which were not controlled for. There may be harmful associations among sons of female dental personnel that were masked by higher social position.

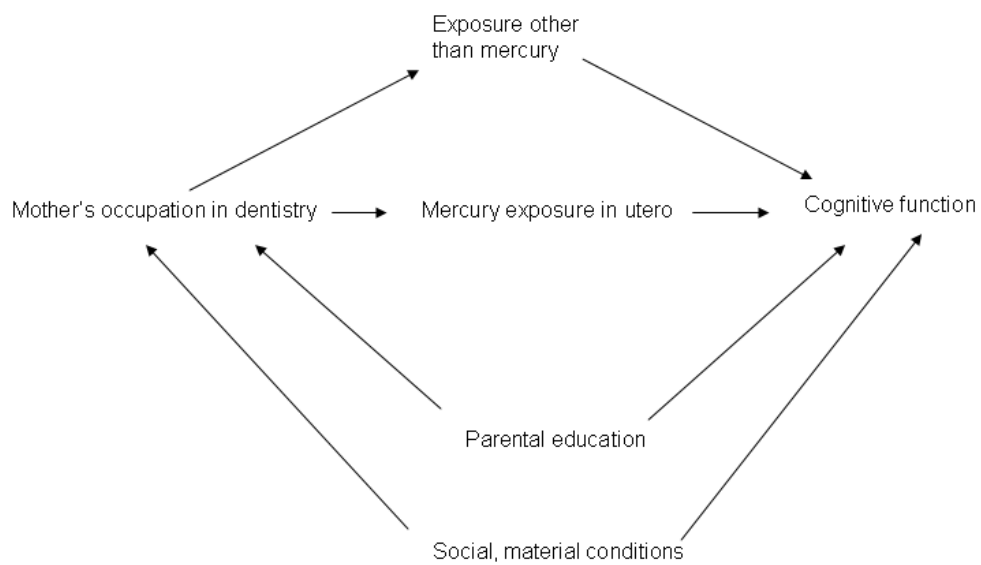

Figure 15. DAG offering an explanation for the association found in Study III.

4.2.7.4 Study IV

In Study IV, comparative analysis of early mortality among the offspring of female health professionals disclosed a statistically significant association between the mother's occupation in dentistry and neonatal mortality in the 1960's. We examined the statistical interaction between the decade and mother's occupation in dentistry and found a statistically significant decrease in HR over the decades. If this is an actual causal effect, it seems likely that the relative risk would decrease, as exposure to mercury decreased over the same time period (Figure 16). The results of Study III suggested that the social standing of the offspring of dental nurses was higher than that of the sons of assistant nurses and that this difference was not completely controlled for by parental education. If that is the case, it is likely that a true causal effect would be somewhat masked in this study. Yet as the number of deaths was quite small, there is also the risk of a chance finding.

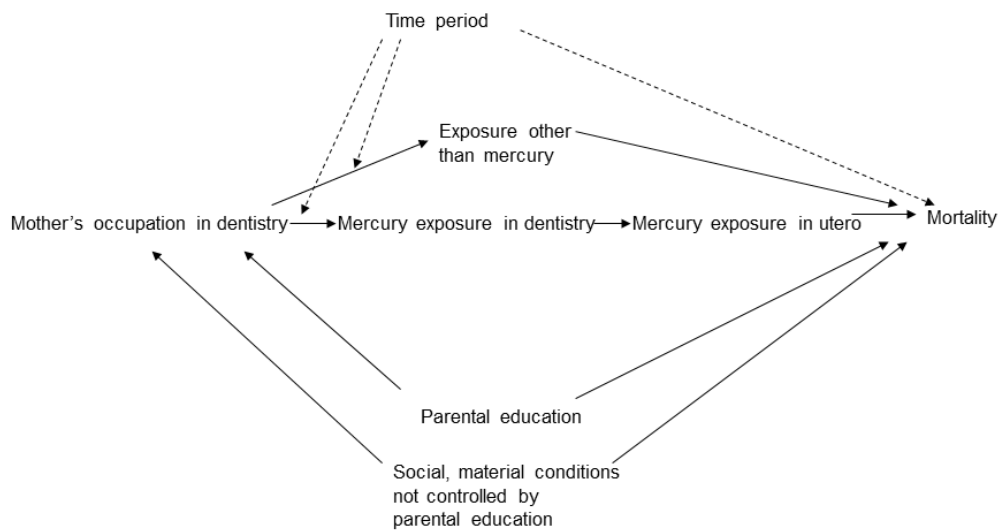

Figure 16. DAG showing potential explanations for the findings in Study IV.

4.3 GENERAL DISCUSSION AND FUTURE RESEARCH

There is still uncertainty about a causal relationship between dental amalgam fillings and health impairment and the potential treatment effects of replacing filling materials. The treatment effects or lack of improvement in health are difficult to interpret: while persistent health impairment after treatment might be interpreted as no treatment effect, it might also be attributable to permanent irreversible damage to organ systems, caused by exposure to mercury. As discussed earlier, self-reported health improvement following filling replacement has several potential explanations besides the decreased mercury exposure. This is a challenging field for future research, where further investigation is warranted to find ways of rehabilitating this group of patients.

Conditions in Sweden may limit further research into these issues. Amalgam is no longer in use and the number of patients presenting with these problems is declining. It may be difficult to justify the use of further resources for research into a problem which now affects relatively few people in Sweden. On the other hand, dental amalgam is still in use in most other parts of the world and so increased knowledge of the purported health implications is still relevant (91). It might be feasible to study populations in countries where amalgam use is still extensive. There seems to be a genetic factor which increases susceptibility to mercury toxicity and more clinical research into this subject would be an important step for the future (92-94). Amalgam removal has been associated with decreased levels of cytokines: further investigation is warranted of a possible relationship between activation of the inflammatory system and health complaints associated with dental amalgam (95).

With reference to the potential risks posed by exposure to mercury by dental personnel and their offspring, continued research in Sweden might not be feasible: now that amalgam use has been discontinued, the level of mercury exposure among dental personnel is low. Such research could be conducted more readily in clinical settings where amalgam is still in use and mercury hygiene varies, for example in less developed countries. In this context, identifying health risks related to occupational exposure to mercury would be potentially more beneficial, as it might lead to measures to improve mercury hygiene with respect to the use of amalgam. A possible extension of Study IV would be the inclusion of female offspring in future studies. Other questions warranting further investigation are the estimation of exposure levels and searching for more detailed information about the causes of neonatal death.

5 CONCLUSIONS

The present study showed that the self-perceived health of patients who have undergone subsidized dental amalgam replacement continues to be poor several years after application for restoration replacement. This finding tends to support the opinion that replacement of restorations alone is insufficient to achieve improved health and HRQoL in patients with symptoms allegedly attributable to dental restorative materials.

Dental filling replacement does not seem to improve workforce participation. Ill health related to dental materials is likely to be associated with dependence on social security benefits. The failure of present measures to achieve an improved HRQoL in these patients and facilitate a return to workforce participation, with subsequent reliance on social benefits, is not only unsatisfactory for the individual patient, but also represents an unacceptable financial burden on society: to the cost of subsidizing filling replacement must be added the considerable cost of life-long social security benefits. The results indicate that further investigation is warranted to find ways of rehabilitating this group of patients and to improve their chances of returning to the workforce.

The studies disclosed no evidence that the male offspring of female dental workers in Sweden suffered from impaired cognitive function. Our results indicate that there was no increased risk for such teratogenic effects during the study period, when the levels of elemental mercury in dentistry were much higher than in Sweden today. An increased risk for impaired cognitive function of offspring to mothers working in modern dentistry seems highly unlikely. In some parts of the world where mercury exposure in dental offices still are at levels comparable with those in our study period, these results suggest that related occupational exposure among female dental workers will not adversely influence cognitive function among their offspring.

There were indications of a higher mortality rate in the offspring of female dental professionals. If such an effect exists, these results suggest that it is limited to neonatal mortality and this putative risk has diminished in Sweden since the 1960's.

6 SVENSK SAMMANFATTNING

Amalgam är ett av de mest använda materialen för att laga hål i tänderna och har varit det sedan tidigt artonhundratals. Det är ett material med fördelaktiga egenskaper för att återuppbygga skadade tänder, men användandet har omgärdats av debatt och misstankar om att vara farligt nästan lika länge som det har använts. Att amalgam innehåller kvicksilver som är välkänt för sin giftighet är orsaken till oron för att det ska vara hälsovådligt. Oron rör inte bara patienter med amalgamfyllningar i tänderna, utan också tandvårdspersonal utsätts för kvicksilverånga i sitt arbete med amalgam.

Syftet med den här avhandlingen var att få mer kunskap och förståelse kring patienter med hälsoproblem som de kopplar till tandfyllningsmaterial och att studera om barn till kvinnor som arbetat inom tandvården har påverkats av att mamman arbetat med kvicksilver.

Vi undersökte patienter som ansökt om att få byta ut sina tandfyllningar på grund av hälsoproblem som de kopplat till fyllningarna. Riskerna för hälsoeffekter hos barn till mammor som arbetat med amalgam i tandvården undersöktes genom att vi studerade söner till kvinnor som arbetade i den svenska tandvården under en tidsperiod då amalgam var det huvudsakliga tandfyllningsmaterialet.

I studie I undersökte vi symptom, upplevda hälsoförändringar och hälsorelaterad livskvalitet bland sökande om tandfyllningsbyte. Vi använde ett frågeformulär för att samla in informationen. Resultaten visade att de sökande hade avsevärt sämre livskvalitet än befolkningen i Sverige i allmänhet och hade omfattande hälsobesvär. Resultaten indikerar att tandfyllningsbyte i sig är otillräcklig för att hjälpa de här patienterna till god hälsa.

I studie II kartlades de sökande om tandfyllningsbytes användning av samhällets skyddsnet. Uppgifterna samlades in från svenska register för åren 1994 till 2006. Patienterna som ansökt om att få byta fyllningar var i högre grad beroende av förtidspension och sjukskrivning än den svenska befolkningen i allmänhet. Skillnaderna mot den övriga befolkningen ökade under uppföljningen. Bland patienterna som ansökt om att byta fyllningar ökade antalet sjukdagar fram till det år de ansökte om att få byta fyllningar. Efter det minskade sjukskrivningen men förtidspension fortsatte att öka i högre takt än sjukskrivningen minskade. Slutsatserna var att patienterna med hälsoproblem som de kopplar till tandfyllningsmaterial i hög grad är beroende av ekonomiskt stöd från samhället. Tandfyllningsbyte framstår inte som en faktor som hjälper patienterna att komma i arbete.

Studie III undersöktes intellektuella funktioner hos söner till kvinnliga tandläkare och tandsköterskor som arbetat i tandvården under en tidsperiod då tänder i huvudsak lagades med amalgam. De intellektuella funktionerna jämfördes med söner till undersköterskor för tandsköterskornas söner och söner till läkare för tandläkarnas

söner. Det som jämfördes var deras resultat på ett test av intellektuella funktioner som genomförts då de mönstrat inför militärtjänstgöring. All information till studien hämtades från register som finns hos olika myndigheter. Vi hittade inga tecken på sämre intellektuella funktioner hos söner till kvinnliga tandläkare eller tandsköterskor då söner till tandvårdspersonal hade liknande eller högre resultat jämfört med kontrollgrupperna vars mödrar arbetat i sjukvården.

I studie IV undersöktes om det fanns en ökad risk att dö tidigt i livet hos söner till tandvårdspersonal. Dödligheten jämfördes med samma grupper som i studie III. Återigen samlades informationen in från svenska register. Bland söner som föddes under 1960-talet fanns en ökad risk att dö under den första levnadsmånaden för söner till tandsköterskor jämfört med undersköterskesöner. De relativa skillnaderna minskade de följande decennierna. Att den minskade dödligheten följde minskningen av amalgamanvändning i tandvården får ses som ett intressant fynd som stärker antagandet att det kan vara en effekt av amalgamanvändandet. Resultaten bör tolkas med försiktighet men det stödjer antagandet att det fanns en måttligt ökad risk för dödlighet under den första levnadsmånaden hos söner till kvinnor som arbetat inom tandvården under graviditeten, under den tidsperiod då de utsattes för mest kvicksilver.

ACKNOWLEDGEMENTS

I am very grateful for the privilege of studying for my PhD at The Karolinska Institutet.

I wish to acknowledge the contributions of many colleagues, family members and friends. Without their encouragement and support, this project could not have come to fruition.

Special thanks are due to

My dedicated supervisors, Gunilla Sandborgh Englund, Pia Svedberg, Kristina Alexanderson and Scott Montgomery, for guiding and encouraging me throughout this project;

Jan Ekstrand, for the opportunity to participate not only in this research project, but also The Research School in Epidemiology;

Sofia Tranaeus, my mentor, for unfailing support and boosting my self-confidence;

My friends and colleagues, Lena Karlsson, Peggy Näsman, Kåre Buhlin and Alfheidur Astvaldsdottir, for sharing the everyday ups and downs of a research student's life;

Colleagues at the Cariology unit: Conny, Lars-Erik, Magda, Stein, Margaret and all the others;

Joan Bevenius, for language revision of my papers and thesis;

Inger Wårdh, for our collaboration on student projects;

Odontologiska Föreningen;

All former co-workers at Medicinsk Tandvård at Huddinge and AGEA Medicinsk Tandvård, Peter Lundholm and Royne Thorman for guidance in my clinical work as a hospital dentist and for unfailing encouragement of my research;

Helen Frylmark, for sharing daily issues in the clinic and rescuing me in troublesome situations;

Gudmundur Axelsson, for inspiring me to apply scientific principles to my clinical work;

Anders Ekblom, for inspiring our research projects and The Research School in Epidemiology;

Karin Ekström Smedby, director of studies at The Research School in Epidemiology;

My study group at the Research School; David, Cecilia, Sophie and Malin;

Former and current PhD students in our department. Nikos, Sofia, Abier, Nilminie, Sara, Maha, Tassos, Jannis, Tove, Taraneh, Anna and others too numerous to mention;

The Summer School on Modern Methods in Biostatistics and Epidemiology;

My beloved Hedvig, Mamma and Pappa and my siblings Clara and Frej. I can always rely on you.

I further acknowledge financial support for the project, provided by grants from The National Board of Health and Welfare, The Swedish Dental Society, the Swedish Society of Medicine and Karolinska Institutet.

.

REFERENCES

1. Bjorklund G. [The history of dental amalgam]. *Tidsskr Nor Laegeforen*. 1989;109(34-36):3582-5. Epub 1989/12/10. Fra tannamalgamets historie.
2. Bird DJ. The amalgam war: an historical review. *N Y State Dent J*. 1972;38(1):5-8. Epub 1972/01/01.
3. Hyson JM, Jr. Amalgam: Its history and perils. *J Calif Dent Assoc*. 2006;34(3):215-29. Epub 2006/08/10.
4. Leonhardt T. [The amalgam syndrome from a historical perspective. The Swedish amalgam disease epidemics]. *Lakartidningen*. 2001;98(37):3940-5, 7-8. Epub 2001/10/06. Amalgamsyndromet ur ett idehistoriskt perspektiv. Den svenska amalgamsjukepidemin.
5. UNEP. MERCURY TIME TO ACT. In: Division of Technology IaECB, editor. Geneva, Switzerland 2013.
6. UNEP. Global Mercury Assessment 2013: Sources, Emissions, Releases and Environmental Transport. In: UNEP Chemicals Branch G, Switzerland, editor. 2013.
7. ATSDR. Toxicological profile for mercury. In: Services UDoHaH, editor.: Agency for Toxic Substances and Disease Registry; 1999.
8. Clarkson TW, Magos L. The toxicology of mercury and its chemical compounds. *Crit Rev Toxicol*. 2006;36(8):609-62. Epub 2006/09/16.
9. Clarkson TW, Vyas JB, Ballatori N. Mechanisms of mercury disposition in the body. *Am J Ind Med*. 2007;50(10):757-64. Epub 2007/05/05.
10. Ekstrand J, Bjorkman L, Edlund C, Sandborgh-Englund G. Toxicological aspects on the release and systemic uptake of mercury from dental amalgam. *Eur J Oral Sci*. 1998;106(2 Pt 2):678-86. Epub 1998/05/19.
11. Olstad ML, Holland RI, Wandel N, Pettersen AH. Correlation between amalgam restorations and mercury concentrations in urine. *J Dent Res*. 1987;66(6):1179-82. Epub 1987/06/01.
12. Sallsten G, Thoren J, Barregard L, Schutz A, Skarping G. Long-term use of nicotine chewing gum and mercury exposure from dental amalgam fillings. *J Dent Res*. 1996;75(1):594-8. Epub 1996/01/01.
13. Geier DA, Carmody T, Kern JK, King PG, Geier MR. A dose-dependent relationship between mercury exposure from dental amalgams and urinary mercury levels: a further assessment of the Casa Pia Children's Dental Amalgam Trial. *Human & experimental toxicology*. 2012;31(1):11-7. Epub 2011/08/02.
14. Isacson G, Barregard L, Selden A, Bodin L. Impact of nocturnal bruxism on mercury uptake from dental amalgams. *Eur J Oral Sci*. 1997;105(3):251-7. Epub 1997/06/01.
15. Sandborgh-Englund G, Elinder CG, Langworth S, Schutz A, Ekstrand J. Mercury in biological fluids after amalgam removal. *J Dent Res*. 1998;77(4):615-24. Epub 1998/04/16.
16. Begerow J, Zander D, Freier I, Dunemann L. Long-term mercury excretion in urine after removal of amalgam fillings. *Int Arch Occup Environ Health*. 1994;66(3):209-12. Epub 1994/01/01.
17. Kingman A, Albertini T, Brown LJ. Mercury concentrations in urine and whole blood associated with amalgam exposure in a US military population. *J Dent Res*. 1998;77(3):461-71. Epub 1998/03/13.
18. Baelum J, Pöckel H. Reference document on exposure to metallic mercury and the development of symptoms with emphasis on neurological and neuropsychological diseases or complaints. Odense: Department of Occupational and Environmental Medicine, Odense University Hospital, 2007.
19. Melchart D, Vogt S, Kohler W, Streng A, Weidenhammer W, Kremers L, et al. Treatment of health complaints attributed to amalgam. *J Dent Res*. 2008;87(4):349-53.

20. Barregard L, Sallsten G, Jarvholm B. People with high mercury uptake from their own dental amalgam fillings. *Occup Environ Med.* 1995;52(2):124-8. Epub 1995/02/01.
21. Bose-O'Reilly S, Lettmeier B, Gothe RM, Beinhoff C, Siebert U, Drasch G. Mercury as a serious health hazard for children in gold mining areas. *Environmental research.* 2008;107(1):89-97.
22. Svendsen K, Syversen T, Melo I, Hilt B. Historical exposure to mercury among Norwegian dental personnel. *Scand J Work Environ Health.* 2010;36(3):231-41. Epub 2009/12/03.
23. Joselow MM, Goldwater LJ, Alvarez A, Herndon J. Absorption and excretion of mercury in man. XV. Occupational exposure among dentists. *Arch Environ Health.* 1968;17(1):39-44. Epub 1968/07/01.
24. Lenvik K, Woldbæk T, Halgard K. Kvikksølveksponering blant tannhelsepersonell: en presentasjon av historiske måledata [Exposure to mercury among dental personnel: a presentation of historic measurement data; English summary]. *Nors Tannlegeforenings Tid.* 2006;116(6):350-6.
25. Nilsson B. Mercury in dental practice. II. Urinary mercury excretion in dental personnel. *Swed Dent J.* 1986;10(6):221-32. Epub 1986/01/01.
26. Langworth S, Sallsten G, Barregard L, Cynkier I, Lind ML, Soderman E. Exposure to mercury vapor and impact on health in the dental profession in Sweden. *J Dent Res.* 1997;76(7):1397-404. Epub 1997/07/01.
27. Bjornberg KA, Vahter M, Berglund B, Niklasson B, Blennow M, Sandborgh-Englund G. Transport of methylmercury and inorganic mercury to the fetus and breast-fed infant. *Environ Health Perspect.* 2005;113(10):1381-5.
28. Sandborgh-Englund G, Ask K, Belfrage E, Ekstrand J. Mercury exposure in utero and during infancy. *J Toxicol Environ Health A.* 2001;63(5):317-20.
29. Palkovicova L, Ursinyova M, Masanova V, Yu Z, Hertz-Picciotto I. Maternal amalgam dental fillings as the source of mercury exposure in developing fetus and newborn. *Journal of exposure science & environmental epidemiology.* 2008;18(3):326-31.
30. Furhoff AK, Tomson Y, Ilie M, Bagedahl-Strindlund M, Larsson KS, Sandborgh-Englund G, et al. A multidisciplinary clinical study of patients suffering from illness associated with release of mercury from dental restorations. Medical and odontological aspects. *Scand J Prim Health Care.* 1998;16(4):247-52. Epub 1999/02/05.
31. Melchart D, Wuhr E, Weidenhammer W, Kremers L. A multicenter survey of amalgam fillings and subjective complaints in non-selected patients in the dental practice. *Eur J Oral Sci.* 1998;106(3):770-7.
32. Ahlqwist M, Bengtsson C, Furunes B, Hollender L, Lapidus L. Number of amalgam tooth fillings in relation to subjectively experienced symptoms in a study of Swedish women. *Community Dent Oral Epidemiol.* 1988;16(4):227-31. Epub 1988/08/01.
33. Bailer J, Rist F, Rudolf A, Staehle HJ, Eickholz P, Triebig G, et al. Adverse health effects related to mercury exposure from dental amalgam fillings: toxicological or psychological causes? *Psychol Med.* 2001;31(2):255-63. Epub 2001/03/10.
34. Langworth S, Bjorkman L, Elinder CG, Jarup L, Savlin P. Multidisciplinary examination of patients with illness attributed to dental fillings. *J Oral Rehabil.* 2002;29(8):705-13. Epub 2002/09/11.
35. Sundstrom A, Bergdahl J, Nyberg L, Bergdahl M, Nilsson LG. Stressful negative life events and amalgam-related complaints. *Community Dent Oral Epidemiol.* 2011;39(1):12-8. Epub 2010/08/26.
36. Bellinger DC, Daniel D, Trachtenberg F, Tavares M, McKinlay S. Dental amalgam restorations and children's neuropsychological function: The New England children's amalgam trial. *Environmental Health Perspectives.* 2007;115(3):440-6.
37. Bellinger DC, Trachtenberg F, Barregard L, Tavares M, Cernichiari E, Daniel D, et al. Neuropsychological and renal effects of dental amalgam in children - A randomized clinical trial. *Jama-Journal of the American Medical Association.* 2006;295(15):1775-83.

38. Bellinger DC, Trachtenberg F, Daniel D, Zhang A, Tavares MA, McKinlay S. A dose-effect analysis of children's exposure to dental amalgam and neuropsychological function - The new England children's amalgam trial. *Journal of the American Dental Association*. 2007;138(9):1210-6.
39. Bellinger DC, Trachtenberg F, Zhang A, Tavares M, Daniel D, McKinlay S. Dental amalgam and psychosocial status: The new England children's amalgam trial. *Journal of Dental Research*. 2008;87(5):470-4.
40. Lygre GB, Gjerdet NR, Bjorkman L. Patients' choice of dental treatment following examination at a specialty unit for adverse reactions to dental materials. *Acta Odontol Scand*. 2004;62(5):258-63.
41. Lygre GB, Gjerdet NR, Bjorkman L. A follow-up study of patients with subjective symptoms related to dental materials. *Community Dent Oral Epidemiol*. 2005;33(3):227-34.
42. Sjursen TT, Lygre GB, Dalen K, Helland V, Laegreid T, Svahn J, et al. Changes in health complaints after removal of amalgam fillings. *J Oral Rehabil*. 2011. Epub 2011/04/27.
43. Meyer-Baron M, Schaeper M, Seeber A. A meta-analysis for neurobehavioural results due to occupational mercury exposure. *Arch Toxicol*. 2002;76(3):127-36. Epub 2002/04/23.
44. Meyer-Baron M, Schaeper M, van Thriel C, Seeber A. Neurobehavioural test results and exposure to inorganic mercury: in search of dose-response relations. *Arch Toxicol*. 2004;78(4):207-11. Epub 2003/11/05.
45. Piikivi L, Hanninen H. Subjective symptoms and psychological performance of chlorine-alkali workers. *Scand J Work Environ Health*. 1989;15(1):69-74. Epub 1989/02/01.
46. Echeverria D, Woods JS, Heyer NJ, Rohlman DS, Farin FM, Bittner AC, Jr., et al. Chronic low-level mercury exposure, BDNF polymorphism, and associations with cognitive and motor function. *Neurotoxicol Teratol*. 2005;27(6):781-96. Epub 2005/11/23.
47. Ritchie KA, Gilmour WH, Macdonald EB, Burke FJ, McGowan DA, Dale IM, et al. Health and neuropsychological functioning of dentists exposed to mercury. *Occup Environ Med*. 2002;59(5):287-93. Epub 2002/05/02.
48. Thygesen LC, Flachs EM, Hanehoj K, Kjuus H, Juel K. Hospital admissions for neurological and renal diseases among dentists and dental assistants occupationally exposed to mercury. *Occup Environ Med*. 2011;68(12):895-901. Epub 2011/04/22.
49. Huang CF, Liu SH, Hsu CJ, Lin-Shiau SY. Neurotoxicological effects of low-dose methylmercury and mercuric chloride in developing offspring mice. *Toxicol Lett*. 2011;201(3):196-204. Epub 2011/01/05.
50. Danielsson BR, Fredriksson A, Dahlgren L, Gardlund AT, Olsson L, Dencker L, et al. Behavioural effects of prenatal metallic mercury inhalation exposure in rats. *Neurotoxicol Teratol*. 1993;15(6):391-6. Epub 1993/11/01.
51. Fredriksson A, Dahlgren L, Danielsson B, Eriksson P, Dencker L, Archer T. Behavioural effects of neonatal metallic mercury exposure in rats. *Toxicology*. 1992;74(2-3):151-60. Epub 1992/09/01.
52. De Rosis F, Anastasio SP, Selvaggi L, Beltrame A, Moriani G. Female reproductive health in two lamp factories: effects of exposure to inorganic mercury vapour and stress factors. *Br J Ind Med*. 1985;42(7):488-94. Epub 1985/07/01.
53. Ericson A, Kallen B. Pregnancy outcome in women working as dentists, dental assistants or dental technicians. *Int Arch Occup Environ Health*. 1989;61(5):329-33.
54. Heggland I, Irgens A, Tollanes M, Romundstad P, Syversen T, Svendsen K, et al. Pregnancy outcomes among female dental personnel--a registry-based retrospective cohort study. *Scand J Work Environ Health*. 2011;37(6):539-46. Epub 2011/06/17.
55. Roeleveld N, Zielhuis GA, Gabreels F. Mental retardation and parental occupation: a study on the applicability of job exposure matrices. *Br J Ind Med*. 1993;50(10):945-54.

56. Rowland AS, Baird DD, Weinberg CR, Shore DL, Shy CM, Wilcox AJ. The effect of occupational exposure to mercury vapour on the fertility of female dental assistants. *Occup Environ Med.* 1994;51(1):28-34. Epub 1994/01/01.
57. Sikorski R, Juskiewicz T, Paszkowski T, Szprengier-Juskiewicz T. Women in dental surgeries: reproductive hazards in occupational exposure to metallic mercury. *Int Arch Occup Environ Health.* 1987;59(6):551-7. Epub 1987/01/01.
58. Dahl JE, Sundby J, Hensten-Pettersen A, Jacobsen N. Dental workplace exposure and effect on fertility. *Scand J Work Environ Health.* 1999;25(3):285-90. Epub 1999/08/18.
59. Larsson KS. The dissemination of false data through inadequate citation. *J Intern Med.* 1995;238(5):445-50. Epub 1995/11/01.
60. Daniels JL, Rowland AS, Longnecker MP, Crawford P, Golding J. Maternal dental history, child's birth outcome and early cognitive development. *Paediatric and perinatal epidemiology.* 2007;21(5):448-57.
61. The Swedish Code of Statutes SFS 1998:1338, (1998).
62. Ludvigsson JF, Otterblad-Olausson P, Pettersson BU, Ekblom A. The Swedish personal identity number: possibilities and pitfalls in healthcare and medical research. *Eur J Epidemiol.* 2009;24(11):659-67. Epub 2009/06/09.
63. Sullivan M, Karlsson J, Taft C. SF-12 Hälsoenkät: Svensk användarhandbok (SF-12 Health Survey: Swedish User Handbook). Gothenburg: Sahlgrenska University Hospital; 1997.
64. Ringsberg KC, Alexanderson KA, Borg KE, Hensing GK. The health-line--a method for collecting data on self-rated health over time: a pilot study. *Scand J Public Health.* 2001;29(3):233-9. Epub 2001/10/30.
65. Sweden S. Background Facts, Labour and Education Statistics 2009:1, Integrated database for labour market research. 2009.
66. Ekblom A. The Swedish Multi-generation Register. *Methods Mol Biol.* 2011;675:215-20. Epub 2010/10/16.
67. Carlstedt B. Cognitive abilities - aspects of structure, process and measurement. Gothenburg: University of Gothenburg; 2000.
68. Zammit S, Allebeck P, David AS, Dalman C, Hemmingsson T, Lundberg I, et al. A longitudinal study of premorbid IQ Score and risk of developing schizophrenia, bipolar disorder, severe depression, and other nonaffective psychoses. *Arch Gen Psychiatry.* 2004;61(4):354-60. Epub 2004/04/07.
69. David AS, Malmberg A, Brandt L, Allebeck P, Lewis G. IQ and risk for schizophrenia: a population-based cohort study. *Psychol Med.* 1997;27(6):1311-23. Epub 1997/12/24.
70. Hemmingsson T, Kriebel D, Melin B, Allebeck P, Lundberg I. How does IQ affect onset of smoking and cessation of smoking--linking the Swedish 1969 conscription cohort to the Swedish survey of living conditions. *Psychosom Med.* 2008;70(7):805-10. Epub 2008/07/09.
71. Ludvigsson JF, Andersson E, Ekblom A, Feychting M, Kim JL, Reuterwall C, et al. External review and validation of the Swedish national inpatient register. *BMC Public Health.* 2011;11:450. Epub 2011/06/11.
72. Fitzmaurice GM, Laird NM, Ware JH. *Applied Longitudinal Analysis.* Second edition ed2011.
73. Weidenhammer W, Bornschein S, Zilker T, Eyer F, Melchart D, Hausteiner C. Predictors of treatment outcomes after removal of amalgam fillings: associations between subjective symptoms, psychometric variables and mercury levels. *Community Dent Oral Epidemiol.* 2010;38(2):180-9. Epub 2010/01/16.
74. Sundstrom A, Bergdahl J, Nyberg L, Bergdahl M, Nilsson LG. Cognitive status in persons with amalgam-related complaints. *J Dent Res.* 2010;89(11):1236-40. Epub 2010/08/27.
75. Tillberg A, Berglund A, Marell L, Bergdahl J, Eriksson N, Linden G, et al. Changes in health over time in patients with symptoms allegedly caused by their dental restorative materials. *Community Dent Oral Epidemiol.* 2005;33(6):427-37. Epub 2005/11/03.
76. Lygre GB, Sjørusen TT, Svahn J, Helland V, Lundekvam BF, Dalen K, et al. Characterization of health complaints before and after removal of amalgam fillings - 3-year follow-up. *Acta Odontol Scand.* 2012. Epub 2012/07/04.

77. Finnis DG, Kaptchuk TJ, Miller F, Benedetti F. Biological, clinical, and ethical advances of placebo effects. *Lancet*. 2010;375(9715):686-95. Epub 2010/02/23.
78. Grandjean P, Guldager B, Larsen IB, Jorgensen PJ, Holmstrup P. Placebo response in environmental disease. Chelation therapy of patients with symptoms attributed to amalgam fillings. *J Occup Environ Med*. 1997;39(8):707-14. Epub 1997/08/01.
79. Gustafsson K, Lundh G, Svedberg P, Linder J, Alexanderson K, Marklund S. Disability, sickness, and unemployment benefits among long-term sickness absentees five years before, during, and after a multidisciplinary medical assessment. *J Multidiscip Healthc*. 2011;4:25-31. Epub 2011/04/07.
80. Alexanderson K, Norlund A. Swedish Council on Technology Assessment in Health Care (SBU). Chapter 1. Aim, background, key concepts, regulations, and current statistics. *Scand J Public Health Suppl*. 2004;63:12-30. Epub 2004/10/30.
81. Karpansalo M, Manninen P, Kauhanen J, Lakka TA, Salonen JT. Perceived health as a predictor of early retirement. *Scand J Work Env Hea*. 2004;30(4):287-92.
82. Mansson NO, Merlo J. The relation between self-rated health, socioeconomic status, body mass index and disability pension among middle-aged men. *European Journal of Epidemiology*. 2001;17(1):65-9.
83. Mansson NO, Rastam L. Self-rated health as a predictor of disability pension and death - A prospective study of middle-aged men. *Scand J Public Healt*. 2001;29(2):151-8.
84. Horsted-Bindslev P. Amalgam toxicity--environmental and occupational hazards. *J Dent*. 2004;32(5):359-65. Epub 2004/06/15.
85. Ask K, Akesson A, Berglund M, Vahter M. Inorganic mercury and methylmercury in placentas of Swedish women. *Environ Health Perspect*. 2002;110(5):523-6.
86. Newland MC, Warfvinge K, Berlin M. Behavioral consequences of in utero exposure to mercury vapor: alterations in lever-press durations and learning in squirrel monkeys. *Toxicol Appl Pharmacol*. 1996;139(2):374-86. Epub 1996/08/01.
87. Lindbohm ML, Ylostalo P, Sallmen M, Henriks-Eckerman ML, Nurminen T, Forss H, et al. Occupational exposure in dentistry and miscarriage. *Occup Environ Med*. 2007;64(2):127-33.
88. Rothman. KJ, Greenland. S, Lash. T. *Modern Epidemiology*. Third edition ed. Philadelphia: LIPPINCOTT WILLIAMS & WILKINS; 2008.
89. Hall P, Adami HO, Trichopoulos D, Pedersen NL, Laggiou P, Ekbom A, et al. Effect of low doses of ionising radiation in infancy on cognitive function in adulthood: Swedish population based cohort study. *Bmj*. 2004;328(7430):19.
90. Miech RA, Hauser RM. Socioeconomic status and health at midlife. A comparison of educational attainment with occupation-based indicators. *Ann Epidemiol*. 2001;11(2):75-84. Epub 2001/02/13.
91. Nascimento MM, Gordan VV, Qvist V, Litaker MS, Rindal DB, Williams OD, et al. Reasons for placement of restorations on previously unrestored tooth surfaces by dentists in The Dental Practice-Based Research Network. *J Am Dent Assoc*. 2010;141(4):441-8. Epub 2010/04/01.
92. Gundacker C, Gencik M, Hengstschlager M. The relevance of the individual genetic background for the toxicokinetics of two significant neurodevelopmental toxicants: mercury and lead. *Mutat Res*. 2010;705(2):130-40. Epub 2010/07/06.
93. Woods JS, Heyer NJ, Echeverria D, Russo JE, Martin MD, Bernardo MF, et al. Modification of neurobehavioral effects of mercury by a genetic polymorphism of coproporphyrinogen oxidase in children. *Neurotoxicol Teratol*. 2012;34(5):513-21. Epub 2012/07/07.
94. Ekstrand J, Nielsen JB, Havarinasab S, Zalups RK, Soderkvist P, Hultman P. Mercury toxicokinetics--dependency on strain and gender. *Toxicol Appl Pharmacol*. 2010;243(3):283-91. Epub 2009/09/08.
95. Bjorkman L, Brokstad KA, Moen K, Jonsson R. Minor changes in serum levels of cytokines after removal of amalgam restorations. *Toxicol Lett*. 2012;211(2):120-5. Epub 2012/04/06.