

From the Division of Biochemistry,
Department of Medical Biochemistry and Biophysics
Karolinska Institutet, Stockholm, Sweden

THIOREDOXIN REDUCTASE AS A TARGET ENZYME FOR ELECTROPHILIC ANTICANCER DRUGS

Sofi Eriksson



**Karolinska
Institutet**

Stockholm 2011

All previously published papers were reproduced with permission from the publisher.

Printed by Larserics Digital Print AB, Sweden.

Published by Karolinska Institutet.

© Sofi Eriksson, 2011

ISBN 978-91-7457-502-6

De omnibus dubitandum

René Descartes

ABSTRACT

Induced production of reactive oxygen species (ROS) is a common attribute of most cancer cells. One strategy for cancer cells to maneuver the increased and potentially toxic levels of ROS is to induce the expression of cellular antioxidants and redox regulators, such as the thioredoxin (Trx) system. The Trx system consists of Trx and the NADPH-dependent thioredoxin reductase (TrxR protein/*Txnrd1* gene). TrxR reduces Trx, which subsequently reduces disulfides in various proteins and supplies ribonucleotide reductase with electrons for DNA synthesis. Mammalian TrxRs have wide substrate specificity, also reducing other targets than Trx. Cytosolic Trx1 and TrxR1 are induced upon oxidative stress and both have proven to be overexpressed in many tumors. They are therefore proposed as potential targets for anticancer therapy. TrxR is a selenoprotein and contains selenium in the form of selenocysteine (Sec). The Sec residue is mostly de-protonated at physiological pH and is highly nucleophilic, thus being easily targeted by electrophilic drugs.

The aim of this thesis was to address the role of TrxR1 as a potential drug target for anticancer therapy and evaluate its importance for side effects associated with the widely used anticancer drug cisplatin (cDDP).

This thesis reports that RITA, a compound shown to induce p53 dependent cell-death by interacting and restoring p53 activity, caused inhibition of TrxR1. Cell culture experiments showed that RITA induced a 130 kDa covalently linked TrxR1-dimer, in a p53 dependent fashion. Furthermore, red wine, rich of polyphenols and flavonoids, was also shown to efficiently inhibit TrxR activity and to be highly toxic to various cancer cell lines.

Transient TrxR1 knockdown in a lung carcinoma cell line lowered the TrxR activity by 90% and caused increased sensitivity towards menadione and 1-chloro-2,4-dinitrobenzene. TrxR1 knockdown cells were, however, more resistant towards cDDP. Depleting the glutathione (GSH) levels in knockdown cells had no effect on cell growth, suggesting that the remaining TrxR activity still was enough to sustain Trx function. Recent experiments in mice showed that normal replication of hepatocytes required either one functional copy of the *Txnrd1* gene or a functional GSH system, agreeing with the previous interpretation.

cDDP treatment is associated with side effects such as ototoxicity and nephrotoxicity. cDDP inhibits TrxR1 and cDDP-derivatized enzyme species have previously been shown to gain a pro-oxidant role in the cells. Data on cDDP-triggered nephrotoxicity in mice presented herein suggest that the degree of kidney damage is influenced by the TrxR status in both liver and kidney. Decreased TrxR activity in liver was associated with more renal damage, while high TrxR expression in kidney correlated with increased kidney toxicity. Pharmacokinetic studies on cDDP and oxaliplatin (Oxa) in guinea pig, showed that the cochlear uptake of cDDP was significantly higher than for Oxa, thus explaining why Oxa only rarely causes ototoxicity. Using a cancer cell line it was also shown that cDDP, but not Oxa, induced cell death which was dependent on calcium and superoxide levels and caused TrxR inhibition.

In summary, this thesis shows that TrxR1 is an anticancer drug target that can have an important impact on the outcome of chemotherapy and its associated side effects.

LIST OF PUBLICATIONS

- I. **Eriksson SE**, Prast-Nielsen S, Flaberg E, Szekeley L, Arnér ES. High levels of thioredoxin reductase 1 modulate drug-specific cytotoxic efficacy. *Free Radic Biol Med.* 2009 Dec 1;47(11):1661-71.
- II. Hedström E, **Eriksson S**, Zawacka-Pankau J, Arnér ES, Selivanova G. p53-dependent inhibition of TrxR1 contributes to the tumor-specific induction of apoptosis by RITA. *Cell Cycle.* 2009 Nov 1;8(21):3576-83.
- III. Wallenborg K, Vlachos P, **Eriksson S**, Huijbregts L, Arnér ES, Joseph B, Hermanson O. Red wine triggers cell death and thioredoxin reductase inhibition: effects beyond resveratrol and SIRT1. *Exp Cell Res.* 2009 May 1;315(8):1360-71.
- IV. Hellberg V, Wallin I, **Eriksson S**, Hernlund E, Jerremalm E, Berndtsson M, Eksborg S, Arnér ES, Shoshan M, Ehrsson H, Laurell G. Cisplatin and oxaliplatin toxicity: importance of cochlear kinetics as a determinant for ototoxicity. *J Natl Cancer Inst.* 2009 Jan 7;101(1):37-47.
- V. Prigge JR, **Eriksson S**, Iverson SV, Meade TA, Capecchi MR, Arnér ES, Schmidt EE. Hepatocyte DNA replication in growing liver requires either glutathione or a single allele of *txnr1*. *Submitted Manuscript*.
- VI. **Eriksson S**, Iverson SV, Prigge JR, Capecchi MR, Arnér ES, Schmidt EE. Thioredoxin reductase 1 status in liver and kidney influences the extent of nephrotoxicity triggered by cisplatin. *Manuscript*.

Articles not included in this thesis:

Brown KK, **Eriksson SE**, Arnér ES, Hampton MB. Mitochondrial peroxiredoxin 3 is rapidly oxidized in cells treated with isothiocyanates. *Free Radic Biol Med.* 2008 Aug 15;45(4):494-502.

Iverson SV, **Eriksson S**, Xu J, Prigge JR, Meade TA, Talago EA, Meade E, Capecchi MR, Arnér ES, Schmidt EE. Genetic disruption of hepatocyte TrxR1 expression attenuates acetaminophen-induced liver damage in mice. *Manuscript*.

TABLE OF CONTENTS

1	Introduction	1
1.1	Cancer	1
1.2	Redox signaling	1
1.3	Cancer and oxidative stress	3
1.3.1	Nrf2 regulation of antioxidants	3
1.4	Mammalian selenoproteins at a glance	4
1.4.1	Biosynthesis of selenoproteins in eukaryotes	5
1.4.2	Selenium nutrition in relation to health and cancer	5
1.5	Antioxidants	6
1.5.1	Low molecular weight antioxidants	6
1.5.2	Antioxidant enzymes	7
1.6	Ribonucleotide reductase	7
1.7	The glutathione system	7
1.7.1	GSH synthesis	8
1.7.2	GPx	8
1.7.3	Grx	9
1.7.4	GSTs	9
1.8	The thioredoxin system	10
1.8.1	The different forms of mammalian Trx and TrxR	10
1.8.2	The Trx system in relation to cancer	10
1.8.3	Trx	11
1.8.4	TrxR	13
2	Aims of this thesis	19
3	Present investigation	21
3.1	Methodology	21
3.1.1	Cell cultures	21
3.1.2	RNA silencing	21
3.1.3	⁷⁵ Se radioisotope labeling	21
3.1.4	Measuring ROS	21
3.1.5	Cell proliferation and viability assays	22
3.1.6	Measuring enzyme activity	22
3.1.7	Guinea pig model for inner ear studies	23
3.1.8	The Cre/LoxP recombination systems	23
3.2	Results and conclusions	26
3.2.1	Paper I	26
3.2.2	Paper II	27
3.2.3	Paper III	28
3.2.4	Paper IV	29
3.2.5	Paper V	30
3.2.6	Paper VI	31
4	Discussion and future perspective	33
5	Acknowledgements	37
	References	39

LIST OF ABBREVIATIONS

ARE	Antioxidant responsive element
AP-1	Activator protein 1
ASK-1	Apoptosis signal-regulating kinase 1
ATP	Adenosine-5'-triphosphate
BSO	L-Buthionine-SR-sulphoximine
cDDP	Cisplatin, cis-Diaminedichloroplatinum
Cys	Cysteine
DNCB	1-chloro-2,4-dinitrobenzene
dNTPs	Deoxyribonucleoside triphosphates
DTNB	5,5'-dithio-bis(2-nitrobenzoic acid)
FAD	Flavin adenine dinucleotide
G6PD	Glucose-6-phosphate dehydrogenase
γ -GCS	γ -Glutamyl cysteine synthetase
GPx	Glutathione peroxidase
GR	Glutathione reductase
Grx	Glutaredoxin
GS	GSH synthetase
GSH/GSSG	Glutathione, reduced/oxidized form
GST	Glutathione-S-transferase
HIF1 α	Hypoxia-inducible factor 1
Keap-1	Kelch-like ECH-associated protein 1
MDM2	Mouse double minute 2
MRP	Multidrug resistance-associated protein / ATP-binding cassette transporters
MS	Mass spectrometry
NADPH	Nicotinamide adenine dinucleotide phosphate
NCS	Primary embryonic neural stem cell
NF- κ B	Nuclear factor kappa-light-chain-enhancer of activated B cells
Nox	NADPH oxidase
Nrf2	Nuclear factor (erythroid-derived 2)-like 2
Oxa	Oxaliplatin, (trans-L-1,2-diaminocyclohexane oxalotoplatinum(II))
Prx	Peroxiredoxin
PTEN	Phosphatase and tensin homolog
RITA	Reactivation of p53 and induction of tumor cell apoptosis
RNR	Ribonucleotide reductase
ROS	Reactive oxygen species
Sec	Selenocysteine / single letter code U
SECIS	Selenocysteine insertion sequence
SecTRAP	Selenium compromised thioredoxin reductase-derived apoptotic proteins
SIRT1	NAD-dependent deacetylase sirtuin-1
SOD	Superoxide dismutase
TBP2	Thioredoxin-binding protein 2
TGR	Thioredoxin and glutathione disulfide reductase
TRP14	Thioredoxin related protein of 14 kDa
Trx	Thioredoxin
TrxR	Thioredoxin reductase protein
Txnrd1	Thioredoxin reductase mouse gene / TXNRD1 human gene
UTR	Untranslated region
xCT	Cystine/glutamate exchange transporter

1 INTRODUCTION

1.1 CANCER

Cancer is an age-related disease and one of the dominant causes of death in high-income countries. In 2009, 54,611 new cases of cancer were diagnosed in Sweden and the calculated risk of developing cancer at some point in life was about 30% [1]. Cancer is a collective name for multiple disorders. Each individual cancer or solid tumor is unique and consists of a heterogenic population of chronically proliferating cells. Cancer is a genetic disease and a series of mutations are often the underlying cause for disturbances in cell signaling pathways. During recent years the scientific research community has expanded our perspectives, looking beyond the tumor mass, realizing there is a complex interplay between the tumor cells and the tissues and molecules surrounding the tumor.

Certain characteristics are however shared by most cancers, which have previously been extensively described by Hanahan and Weinberg [2,3]. The necessary and acquired capability for tumor development includes sustained proliferative signaling, evading growth suppressors, activating invasion and metastasis, enabling replicative immortality, inducing angiogenesis and resisting cell death. Extensive research over the past years has shown that perhaps two additional features should be added to the list, namely the capability to avoid immune destruction and cellular metabolism reprogramming. By up-regulating the glycolysis pathway, tumor cells have for instance adjusted to low oxygen levels, this is called the Warburg effect [4].

1.2 REDOX SIGNALING

Oxygen plays an important role in energy metabolism and the formation of reactive oxygen species (ROS) is therefore a normal consequence of aerobic metabolism [5,6]. ROS are oxygen species that are in a more reactive state than molecular oxygen and encompasses a diverse range of molecular species, for example superoxide ($O_2^{\cdot-}$), hydrogen peroxide (H_2O_2), nitric oxide (NO), peroxyxynitrite ($OONO^{\cdot}$), hypochlorous acid (HOCl) and the hydroxyl radical (OH^{\cdot}). Each of these molecules has its own reaction preferences. ROS can be categorized as free radicals, possessing one or more unpaired electrons, or as non-radical ROS. Reactive nitrogen species (RNS) are many times also regarded separately. Excess levels of ROS can be dangerous to cells but at low and controlled levels they have important physiological functions.

The major endogenous producers of cellular ROS are the mitochondria, which drive the synthesis of adenosine-5'-triphosphate (ATP) via the respiratory chain [7,8,9,10]. Superoxide is produced due to electron leakage, which occurs when electrons passing down the respiratory chain exit prematurely. The two main sites in the respiratory chain where this can happen are complex I (NADH dehydrogenase) and complex III (ubisemiquinone) [11,12]. There are also numerous other sources for ROS production in the mitochondria that are important and significantly affect the total ROS levels. Consequently, the mitochondria are also a central target for ROS toxicity and dedicated antioxidants systems therefore play a crucial role in protecting and sustaining mitochondrial functions. Other

cellular sources of ROS production include nicotinamide adenine dinucleotide phosphate (NADPH) oxidases (Nox), xanthine oxidase, glucose oxidase, lipoxygenases, nitric oxide synthase (NOS), flavoprotein reductases and myeloperoxidase [8]. There are also several possible exogenous ROS sources such as UV-light, ionizing radiation and metabolism of different xenobiotics.

ROS also function as cellular signaling molecules. Superoxide radicals and hydrogen peroxide can modify the activity of nuclear transcription factors such as nuclear factor kappa B (NF-κB) and activator protein-1 (AP-1) [13,14,15]. ROS can furthermore modulate the activity of protein tyrosine kinases and phosphatases. The production of hydrogen peroxide is for instance required for insulin and growth factor-induced tyrosine kinase signaling [16,17,18]. Growth factors will activate Nox enzymes, whose specific subcellular localization regulates specificity and selectivity in oxidant signaling [19,20]. Nox derived reactive oxygen species act as a second messenger and can for example inactivate certain phosphatases. The regulation mechanism is often due to the oxidation and reduction of certain cysteine residues, causing transient inactivation or activation of proteins. This type of reaction is called a redox reaction and involves the transfer of electrons between two compounds. In a redox reaction one molecule loses electrons and become oxidized while the other molecule gain electrons and is thereby reduced. In an oxidizing environment, thiol-groups are often reversibly modified to inter- or intradisulfide bond (-SS-) or a sulfenic (-SOH) acid [8].

Redox homeostasis is the balance between oxidants and antioxidants [6]. An imbalance between oxidants and antioxidants is called oxidative stress. Certain exogenous toxic agents, for instance different quinones, can cause increased amounts of oxygen radicals via redox cycling. Redox cycling reactions are self-perpetuating coupled reactions that many times can lead to the generation of ROS. In the presence of transition metal ions, both superoxide radicals and hydrogen peroxide can form the highly reactive and aggressive hydroxyl radicals (OH[•]) [6].

Hydrogen peroxide can undergo the Fenton reaction:

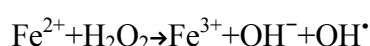

and together with superoxide

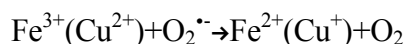

the Haber-Weiss reaction (the net reaction)

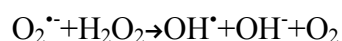

Too high levels of ROS can cause oxidative damage towards cellular compounds such as proteins, nucleic acids, and lipid membranes. Furthermore, breakdown products produced during lipid peroxidation can cause further damage to the cell [21]. The breakdown products are often aldehydes, such as malonaldehyde and 4-hydroxy-2-nonenal (4-HNE), which among other things can covalently modify proteins. Under conditions of oxidative stress superoxide radicals can directly react with nitric oxide (an important signaling molecule of several physiological processes e.g. involved in the cardiovascular system) to form peroxynitrite

(OONO⁻). Peroxynitrite is a highly reactive oxidant involved in protein nitration, which can also convert into other toxic species (OH[•] and NO₂) [22]. The degree of intracellular oxidative stress will result in different cellular outcomes and too high levels of ROS can lead to cell death. The amount of ROS will also determine how the cell will undergo cell death, since several of the proteins involved in the cell death machinery are redox sensitive, for example proteases belonging to the caspase family [23,24].

1.3 CANCER AND OXIDATIVE STRESS

Increased levels of ROS have been implicated in age-associated diseases such as neurodegenerative diseases, atherosclerosis and cancer [9,10,25]. ROS can stimulate cell proliferation and motility, and promote tumor formation and progression [9,26,27,28]. For instance, ROS can inactivate the function of the phosphatase and tensin homolog (PTEN), a known tumor suppressor gene. The inactivation of PTEN effects downstream events and ultimately promotes cellular growth, survival and metabolism [29]. Increased levels of ROS can also induce DNA damage and might cause genomic instability. Enhanced production of cellular ROS can be detected in many cancer cells, and to balance the increased levels of ROS tumor cells very often increase their expression of antioxidant enzymes [30]. The balance between oxidants and antioxidants appears to be more fragile in cancer cells than in normal cells. Chemotherapy mediated increases of intracellular ROS levels could therefore be a general mechanism in several cases of anticancer therapy.

1.3.1 Nrf2 regulation of antioxidants

Many of the proteins that are studied in this thesis show increased gene expression after exposure to oxidative or xenobiotic stress [15,31]. These proteins have antioxidant response element (ARE)-bearing genes that are regulated via the Keap1-Nrf2-ARE signaling pathway. Under non-stressed conditions the transcription factor nuclear factor erythroid 2-related factor 2 (Nrf2) is negatively regulated by kelch-like ECH-associated protein 1 (Keap1), promoting ubiquitin-mediated proteasomal degradation of Nrf2. Keap1 works as an oxidative stress sensor, containing redox sensitive cysteine residues. Changes in the cellular redox homeostasis cause modifications of Keap1 cysteine residues, disrupting the association between Nrf2 and Keap1. Upon release, Nrf2 translocates to the nuclear space and activates ARE-responsive genes. The induction of Nrf2 target gene protects cells against genotoxic damage and cancer initiation [32,33]. However, once a cell has transformed, the Nrf2 activation will rather be an advantage for the cancer cell as this promotes cell proliferation and survival. A high constitutive expression of Nrf2 has for instance been found in certain forms of lung cancer [34,35].

Examples of Nrf2 target genes described in this thesis are: γ -glutamylcysteine synthetase (γ -GCS), γ -glutamyl transferase (γ GGT), glutathione peroxidase 2 (GPx2), glutathione S-transferases (GSTs), glutathione reductase (GR), peroxiredoxin 1 (Prx1), thioredoxin reductase 1 (TrxR1), thioredoxin 1 (Trx1) and the cystine/glutamate exchange transporter (xCT) [36,37,38,39,40]. Additionally, activation of Nrf2 has been shown to increase cellular NADPH production [41].

1.4 MAMMALIAN SELENOPROTEINS AT A GLANCE

The Swedish chemist Jöns Jacob Berzelius, known as the founder of what would later become Karolinska Institutet, discovered the element selenium (Se) in 1817. In the beginning selenium was regarded as an environmental toxin, but during the 1950s it was recognized as an essential trace element for mammals [42,43].

Selenium is most commonly present in proteins in the form of selenocysteine (Sec), which is recognized as the 21st amino acid [44]. Random and non-specific selenium incorporation in the form of selenomethionine can also occur, but in this case the resulting proteins are not defined as selenoproteins [45]. Sec is a cysteine-analogue (see Fig 1) where the sulfur atom is replaced by selenium, hence changing its chemical properties. Sec has, compared to cysteine, a stronger nucleophilicity and a lower pKa value (5.2 for the selenol versus 8.5 for the thiol), resulting in most of the Sec being in the deprotonated selenolate form at physiological pH [44].

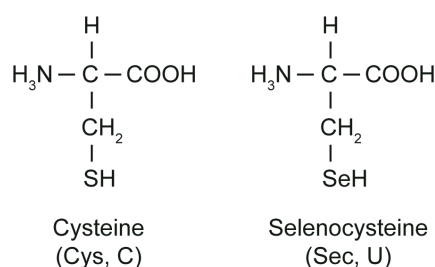

Fig 1. The chemical structure of Cys and Sec.

The number of selenoproteins varies across eukaryotes. Zebrafish, for instance, have 37 selenoproteins while the roundworm *Caenorhabditis elegans* has only one selenoprotein, an orthologue to TrxR1 [45,46]. In humans 25 different selenoprotein coding genes have been found, whereas rodents have 24 recognized selenoproteins. Some organisms lack selenoproteins completely, for instance higher plants and fungal species. However, many of these species have Cys-containing counterparts instead.

In proteins Sec is almost always placed in the active site of enzymes, serving catalytic functions [45,46]. Most of the characterized selenoproteins so far are oxidoreductases and have redox regulatory and protective functions in the cell. Mammalian selenoproteins can generally be divided into two groups based on the location of their Sec-residue. The first group has their Sec-residue close to their C-terminal end and includes proteins like TrxRs and methionine sulfoxide reductase 1B (MsrB1 or selenoprotein R). Msr is a protein involved in protein repair and protects cells against oxidative stress by taking care of oxidized methionine-residues. The second group of selenoproteins has their Sec-residue located in the N-terminal or center regions and includes, for instance, GPxs, iodothyronine deiodinase, and selenophosphate synthetase 2 (SPS2). Only one selenoprotein contains multiple Sec residues, selenoprotein P, hence it cannot be placed in any of the two groups. Selenoprotein P has one Sec, supposedly redox active, located in the N-terminal region of the proteins and nine additional Sec-residues, which are located in the C-terminal domain. Selenoprotein P has a

important role in selenium transport and selenium homeostasis [47]. Selenoproteins, such as selenoprotein I, K, M, O, T have physiological functions which are still largely unknown.

1.4.1 Biosynthesis of selenoproteins in eukaryotes

Sec incorporation is encoded by a dedicated UGA codon, which otherwise usually specifies termination of protein synthesis. Various factors are required for the ribosomes not to recognize the Sec-encoding UGA as a stop codon, the selenocysteine insertion sequence (SECIS) element being one of these essential factors. The SECIS element is an mRNA secondary stem-loop structure normally located in the 3' untranslated region (UTR) of the mRNA [48,49,50]. Its presence does not always lead to Sec incorporation and under certain conditions Cys can be incorporated instead [51,52,53]. This seems to be dependent on selenium availability since mice fed a selenium deficient diet showed incorporation of Cys instead of Sec into TrxR1 [52,53]. The complex needed for the translation and incorporation of Sec consists of the SECIS-binding protein 2 (SBP2), which is associated to the elongation factor EFSec and the Sec specific tRNA, SECp43, and the ribosomal protein L30. SBP2 have different binding affinity towards various SECIS elements and can thereby to some extent regulate the production and the amounts of selenoproteins. Furthermore, increased levels of ROS have been shown to affect the SECIS affinity of SBP2 and result in decreased Sec incorporation [54].

Sec synthesis is special, since it does not occur as a free amino acid in the cell. Instead Sec is synthesized directly onto the tRNA. Sec synthase (SecS) converts the phosphoserine moiety of the tRNA^{sec} into a selenocysteinyl group by using selenophosphate (SePO₃), giving rise to Sec-tRNA^{sec}. The selenophosphate is produced via SPS2 from selenide (Se²⁻) and ATP. *In vitro*, SPS2 has also been shown to generate thiophosphate (SPO₃) by using sulfide (S²⁻) instead of selenide as a substrate. Though, SPS2 has a much lower substrate specificity towards sulfide compared to selenide. Thiophosphate can then potentially be used by SecS, hence leading to the formation of Cys-tRNA^{sec} instead of Sec-tRNA^{sec} [53].

Selenide, in turn, originates from selenite (SeO₃²⁻), which can be reduced to selenide by either the thioredoxin system or glutathione [55,56]. Selenide is highly reactive and can easily oxidize into selenite again. TrxR1 is believed to be the major reductant of selenite in the mammalian system and should therefore be required for selenoprotein synthesis.

1.4.2 Selenium nutrition in relation to health and cancer

In nature, selenium is found in the -2 (selenide), 0 (selenium), +4 (selenite), and +6 (selenate) oxidation states. The dose of 50% lethality (LD50) ranges between 1.5 and 6 mg/kg for many selenium compounds and animal species [57]. Selenium is an essential micronutrient for humans and selenium deficiency is associated with a wide array of diseases including cancer, cardiovascular diseases, male reproductive problems and immune suppression [58,59]. In Sweden and US the recommended daily intake is between 70 and 55 µg Se. Supranutritional selenium supplementation (~ 200 µg Se/day) has been recognized as cancer preventive, though only individuals with low baseline levels of selenium may show reduced

cancer incidence [60,61,62]. The beneficial affects of selenium likely arise from both low molecular weight selenium compounds and selenoproteins [63]. There has also been conflicting data reported concerning selenium supplementation and cancer prevention, which reflects the complexity of the roles of selenium in human health [62]. There is an ongoing discussion arguing that it is not only the amount of selenium intake that is important, but also its form. Furthermore, the level of selenium intake varies substantially between individuals due to dietary reasons. For example, selenium levels in food vary due to geographical location [64,65]. The role of selenium in the biology of human health is still far from fully understood and will continue to be an interesting area of research.

1.5 ANTIOXIDANTS

Antioxidants regulate the cellular redox environment and protect cells against oxygen-induced toxicity. Cellular antioxidants are often divided into two groups, enzymatic and low molecular weight antioxidants [6].

1.5.1 Low molecular weight antioxidants

Ascorbate (vitamin C) is water-soluble antioxidant scavenging radicals such as superoxide- ($O_2^{\bullet -}$), hydroxyl- (OH^{\bullet}), alkoxyl (RO^{\bullet}) peroxy- (ROO^{\bullet}), urate (UH^{\bullet}) and tocopheryl-radicals (TO^{\bullet}) [6]. The tocopheryl radical is reduced by the ascorbate to tocopherol (vitamin E) generating an ascorbyl radical instead. Two ascorbyl radicals can then spontaneously react with each other, forming an ascorbic acid and a dehydroascorbic acid, thereby acting as a radical chain-breaker. α -Tocopherol is the most potent and biologically active form of the tocopherols. It is a lipid-soluble antioxidant that can quench free radicals by becoming a stable radical itself, the tocopheryl-radical, and is thereby protecting the integrity of lipid membranes. Other examples of low molecular weight antioxidants are: R- α -Lipoic acid (thioctic acid), a sulfur-containing antioxidant and enzyme cofactor, and glutathione (GSH), which will be further described in the next section.

Consumption of food and beverages rich in flavonoids and polyphenols is associated with a reduced risk of age-associated diseases [66,67,68]. Several naturally occurring flavonoids and phenolic compounds have been shown to possess antioxidant and anti-inflammatory properties, having chemopreventive- and chemotherapeutic functions. Their abilities as antioxidants include chelating transition metals and scavenging radicals. Their direct cellular antioxidant functions have however been challenged by data showing that polyphenols under certain conditions can act as pro-oxidants [67,69]. A number of flavonoids can form semiquinone- and quinone like metabolites which potentially can redox cycle in the cell and lead to ROS formation. It is suggested that their pro-oxidant action as modifiers of signal transduction pathway is responsible for attributed health beneficial effects. Several of these phenolic chemopreventive compounds have for instance been identified to induce the Nrf2 pathway [32].

1.5.2 Antioxidant enzymes

The glutathione (GSH) system together with the thioredoxin (Trx) system are considered to be the major antioxidant and redox regulatory enzyme systems in the mammalian cells. The list of cellular redox-regulatory enzymes is long and also includes enzymes such as the mitochondrial and cytosolic superoxide dismutases (MnSOD and Cu/ZnSOD), important for catalyzing the dismutation of superoxide, producing hydrogen peroxide and oxygen [70]. Other important enzymes are peroxiredoxins (Prx) and catalase, abundant proteins catalyzing the conversion of hydrogen peroxide to water and oxygen [6,71].

Because the GSH and Trx system are central to this thesis, especially in relation to cancer therapy, these aspects shall be discussed in further detail.

1.6 RIBONUCLEOTIDE REDUCTASE

Ribonucleotide reductase (RNR) catalyzes the rate-limiting step in *de novo* synthesis of 2'-deoxyribonucleotides (dNTPs) from the corresponding ribonucleotides. RNR thereby provides the pool of deoxyribonucleotides required for DNA replication and repair [72,73]. The activity of RNR, as well as its substrate specificity, is highly regulated via allosteric interactions. Besides the salvage pathway of nucleotides, RNR is the only enzyme known to produce dNTPs. RNR is a complex of two dimeric proteins (R1 and R2) and its activity is mostly restricted to the S-phase (synthesis phase), making it a well-suited target for the development of anticancer and antiviral agents. Electrons for the catalytic activity of RNR are provided via the Glutaredoxin (Grx) and Trx system respectively [74,75,76]. Trx and the GSH-dependent electron donor Grx were originally discovered in different strains of *Escherichia coli* (*E.coli*) due to their ability to serve as cofactors for RNR [74,76].

1.7 THE GLUTATHIONE SYSTEM

GSH is a major intracellular antioxidant present in millimolar concentration (0.5-10 mM) [11,77]. GSH is nucleophilic and can directly react with both electrophilic and oxidizing species, or by itself to reduce substrates such as dehydroascorbate. It is also used as a cofactor by glutathione peroxidase (GPx), glutaredoxin (Grx) and glutathione S-transferase (GST) (see Fig 2). Glutathione reductase (GR) is responsible for keeping the cellular GSH pool in a reduced state. GR is a homodimeric flavoprotein and belongs to the family of pyridine nucleotide-disulfide oxidoreductases, reducing the oxidized form of GSH, glutathione disulfide (GSSG), by transferring electrons from its cofactor nicotinamide adenine dinucleotide phosphate (NADPH) [78]. Levels of NADPH are maintained by the cytosolic enzyme glucose-6-phosphate dehydrogenase (G6PD) in the pentose mono phosphate pathway [79].

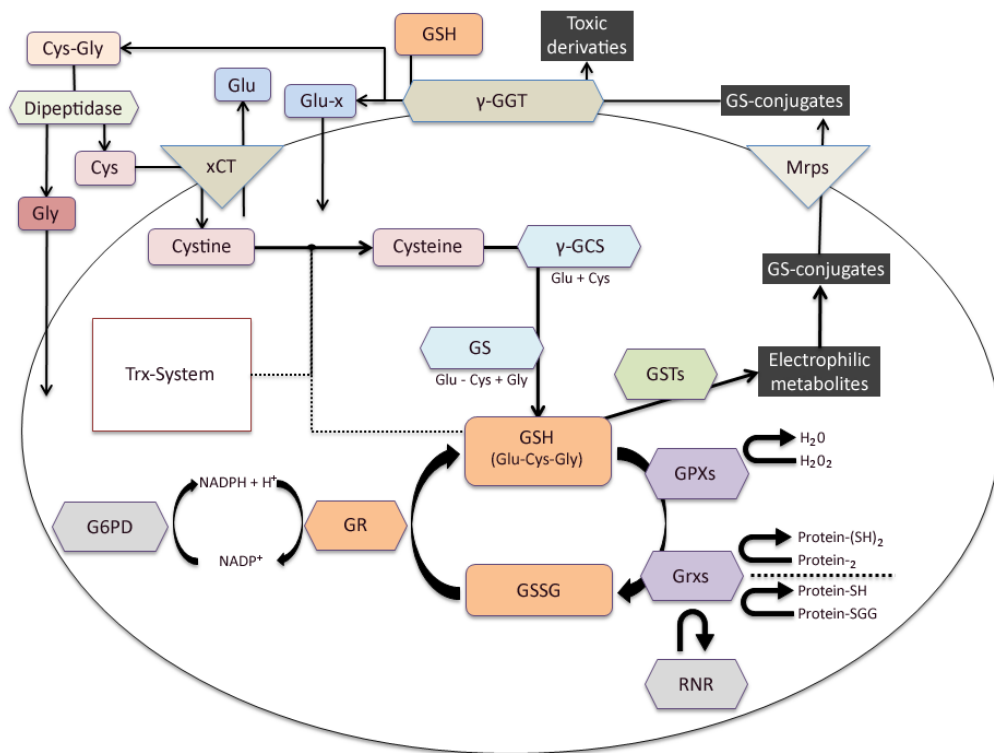

Fig 2. A schematic overview of the GSH system. GSH supports the functions of GPx, Grx and GST, thereby getting oxidized to GSSG. GSH can be regenerated from GSSG by GR using the reductant NADPH+H⁺. γ -GGT is the enzyme catalyzes the first step in GSH salvage pathway. γ -GGT may under certain circumstances metabolize certain GSH-conjugates to more reactive thiols, giving rise to very toxic metabolites. The principle steps of the GSH biosynthesis are also illustrated in the figure.

1.7.1 GSH synthesis

GSH (L- γ -glutamyl-L-cysteinyl-glycine) is a tripeptide comprised of glutamate (Glu), cysteine (Cys) and glycine (Gly). GSH is synthesized by γ -glutamylcysteine synthetase (γ -GCS) and GSH synthetase (GS), where γ -GCS catalyzes the rate-limiting step in *de novo* biosynthesis of GSH. The availability of cysteine is often the limiting and critical factor for the GSH biosynthesis. Cysteine used for the GSH synthesis is for instance provided via the cystine/glutamate exchange transporters (xCT). xCT facilitates the uptake of cystine (Cys-S-S-Cys), which is reduced to cysteine inside the cell, either by the Trx-system or by GSH [36].

1.7.2 GPx

Glutathione peroxidases (GPxs) were the first mammalian proteins discovered to be selenoproteins [43]. Today five selenium-containing GPxs have been identified in humans (GPx1-4 and 6) and the various isoforms of GPx differ in their cellular localization and substrate specificity [80]. GPx protect the cells against oxidative damage by catalyzing the reduction of H₂O₂, organic hydroperoxides and lipid hydroperoxides.

1.7.3 Grx

The two major forms of Grx in mammals are Grx1 and Grx2 (additionally there are two monothiol forms; Grx3 and Grx5) [81]. Upon reduction of substrates, the active site dithiol of Grx gets oxidized, but can be reactivated and reduced by two molecules of GSH. Grx can reduce substrates either by a dithiol or by monothiol mechanism. The monothiol mechanism involves in this case the formation and reduction of protein-GSH mixed disulfides. The reduction of protein-GSH mixed disulfides (deglutathionylation) is often the favored monothiol reaction. Proteins have been shown to be glutathionylated during conditions such as oxidative stress, thus protection and redox regulation could potentially also occur via protein s-glutathionylation [82]. It should be noted that the importance of glutathionylation and its mechanism is still largely unknown. Grx1 contains the active site Cys-Pro-Tyr-Cys and is mainly located in the cytosol. Grx1 acts as a hydrogen donor for RNR and has been shown to redox regulate transcription factors such as nuclear factor κ B (NF- κ B) [83]. Grx2 is localized to the mitochondria and contains the active site Cys-Ser-Tyr-Cys. Grx2 can catalyze deglutathionylation of mitochondrial proteins, and one of its suggested targets is mitochondrial complex I. Interestingly, oxidized Grx2 is not exclusively reduced by GSH but also by thioredoxin reductase (TrxR) [84].

1.7.4 GSTs

Mammalian GSTs are a multi gene family of phase II detoxification enzymes that can be divided into three principle groups, cytosolic, mitochondrial and microsomal GSTs. [85,86]. GSTs catalyse the conjugation of GSH to a large variety of endogenous and exogenous electrophilic compounds, and the addition of GSH usually results in less reactive and more water-soluble compounds. Subsequently GSH conjugates are exported from the cell by multiple drug resistance associated proteins (MRPs or ATP-binding cassette transporters C). There are some cases where the conjugation of GSH can lead to the formation of metabolites that are more reactive than the parent compound [77,87,88]. γ -GGT is catalyzing for the first step in the GSH salvage pathway and can potentially metabolize extracellular GSH-conjugates to more potent and toxic products. γ -GGT is situated on the extracellular cell-surface and normally hydrolysis the γ -glutamyl bond between glutamate and cysteine in excreted GSH. The cleaved glutamate can be transported back into the cell, often after conjugated to an amino acid. The cysteinylglycine is then cleaved by a membrane dipeptidase, generating cysteine and glycine, which also can be taken up by different amino acid transporters and be re-used by the cell.

1.8 THE THIOREDOXIN SYSTEM

The thioredoxin (Trx) system, consisting of thioredoxin, thioredoxin reductase (TrxR) and the cofactor NADPH, is a ubiquitously expressed redox regulatory system. The active site disulfide in oxidized Trx is reduced and thereby reactivated via TrxR, using NADPH as the electron donor [89]. The Trx system has a diverse set of functions in the cell (see Fig 3), which are described in further detail below.

1.8.1 The different forms of mammalian Trx and TrxR

There are two different major forms of Trx in mammals. Trx1 is predominantly found in the cytoplasm and in the nuclei, whereas Trx2 is localized in the mitochondria. Trx1, and a truncated form of Trx1 (Trx80), can also be found extracellularly carrying out immunomodulatory functions [90,91]. The homozygous *Txn1* and *Txn2* knockout mice both show early embryonic lethality [92,93], whereas mice with overexpressed Trx1 showed greater resistance towards oxidative stress [94].

There are three different isoforms of mammalian TrxR; cytosolic TrxR1 [89], mitochondrial TrxR2 [95], and thioredoxin glutathione reductase (TGR) mainly expressed in testis [96]. The homozygous mouse knockouts of *Txnrd1* and *Txnrd2* are both embryonically lethal [97,98,99]. Two different *Txnrd1* knockout mice have been described in the literature, and interestingly these knockouts show somewhat different time-points for embryonic death. With the mouse strain published by Jakupoglu *et al*, where only the last exon of the *Txnrd1* gene was removed, death occurred between embryonic day (ED) 8.5 and 10.5. In contrast, the mouse strain published by Schmidt *et al*, where exons 1 and 2 were deleted, showed embryonic lethality slightly earlier (ED 8.5). The slight difference in lethality between these two strains has a major functional impact, since in the latter strain no mesoderm was formed, whereas it was formed in the strain published by Jakupoglu *et al*. The molecular explanation for these differences is still unknown. Different tissue specific *Txnrd1* knockouts have also been established and have recently been reviewed [100]. Knockout mice with a nervous-system specific deletion of the *Txnrd1* gene experienced ataxia and tremor, and showed incomplete developed of cerebellum [101]. However, the mice with a neuron specific *Txnrd1* gene deletion did not show any phenotype. Moreover, untreated knockouts with either a heart- or hepatocyte specific *Txnrd1* gene deletion showed no obvious phenotype [98,102,103]. *Txnrd1* deficient hepatocytes showed induced Nrf2-dependent gene transcription, which could be seen as a form of compensatory response potentially explaining the lack of phenotype after gene deletion.

1.8.2 The Trx system in relation to cancer

Both Trx and TrxR have been shown to be up-regulated in a large number of tumor cells [104]. In addition, increased expression of Trx1 has been associated with more aggressive tumors and decreased patient survival [104,105,106]. Rapid proliferation and cell growth, with accompanying increased ROS production, is one of the main characteristics of cancer. Inhibition of cellular antioxidant systems in cancer can thereby cause massive accumulation of ROS due to the higher basal ROS output in these cells. The Trx system plays a central role in deoxyribonucleotide production and cellular redox regulation, as described above. Hence, targeted inhibition of the Trx system could have a crucial effect on cell

viability or increase the sensitivity of the tumor cells towards other chemotherapeutic agents. Several of the anticancer drugs available today indeed target the Trx-system. The Trx-system has therefore been proposed to be a potential and promising target for anticancer therapy [107].

It has been implicated that TrxR1 has a role in cancer prevention, but its functions in this context are complex and under certain conditions it seems to take part in promoting cancer [59,108]. The role of TrxR1 in cancer development clearly needs to be further elucidated. Previous results from mice injected with siRNA-mediated TrxR1 knockdown lung carcinoma cancer cells showed that TrxR1 was required to sustain tumorigenic properties [109]. On the other hand, in a different tumor mouse model system where tumor cells had a genetic deletion of the *Txnrd1* gene, the expression of TrxR1 was not required for the tumorigenesis [110]. These studies further illustrate the complexity at play. Some other important factors in need of consideration are base line levels of selenium and TrxR activity levels, effects of TrxR depletion on compensatory systems and of course other genetic differences.

1.8.3 Trx

Trx is a small (~12 kDa) and globular disulfide reductase with a conserved Cys-Gly-Pro-Cys active site, present throughout all kingdoms of life [111]. Besides providing RNR with reducing equivalents, Trx1 catalyzes the reduction of peroxiredoxins (Prx) [71] and methionine sulfoxide reductase (Msr) [112]. Reduced Trx1 has also been shown to block the degradation of I- κ B in the cytosol, preventing nuclear translocation of NF- κ B. In the nuclear compartment, Trx1 affects the function of several transcription factors, by reducing critical cysteine residues. The regulation either occurs directly, reducing the transcription factor NF- κ B for example [113,114,115], or indirectly via redox factor-1 (APE/Ref-1), which can reduce activator protein 1 (AP-1) and HIF1 α [116,117]. In addition, the total protein levels of HIF1 α also seem to be affected by the Trx1 activity [118]. Examples of *in vitro* non-protein substrates of Trx1 are GSSG, insulin and H₂O₂ [119,120]. In *Drosophila melanogaster*, all GSSG is reduced not by GR but by Trx and it is thus possible that a similar Trx-dependent backup system for GSSG reduction exists also in mammalian cells [121].

Trx may also act as a molecular switch, activating/inactivating target protein and thus down-stream signaling events. The reduced form of Trx1 can noncovalently interact with apoptosis signal-regulating kinase (ASK1) [122] and PTEN and thus acts a negative regulator [123]. The association is redox dependent and upon oxidation of Trx the complexes are dissociated. Trx1 can also interact with the thioredoxin binding protein 2 (TBP2), which as been identified as a negative regulator of Trx1 [124].

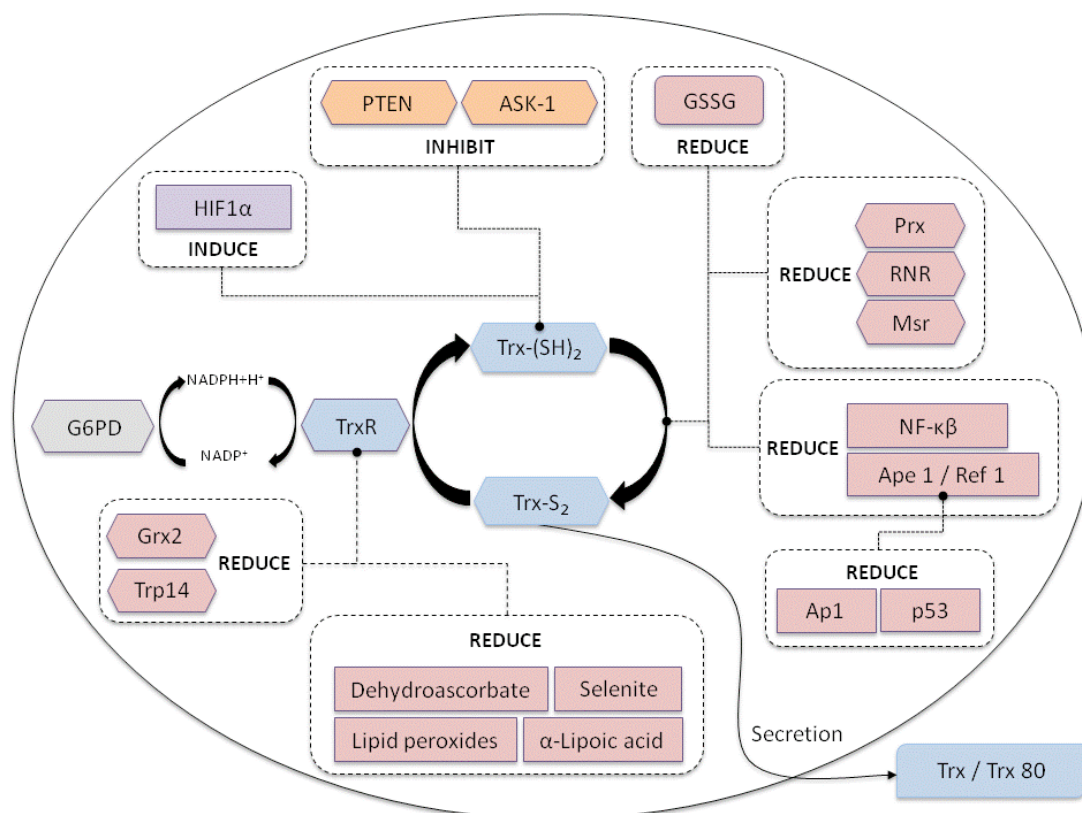

Fig 3. Schematic illustration of the Trx system and its principal cellular functions. The Trx-system acts as an electron donor for e.g. Prx, RNR, and Msr proteins. Trx also act as a redox dependent molecular switch, regulating the activity of target proteins such as ASK1 and PTEN. Trx is kept in a reduced state via TrxR, using NADPH as a source of electrons. TrxR may also reduce several other cellular targets, both other proteins, e.g. TRP14, and low-molecular weight compounds such as lipoic acid and dehydroascorbate.

1.8.3.1 The Trx system in relation to p53 activity

p53 is a transcription factor regulating genes involved in cell cycle arrest, DNA-repair, senescence and cell death [125]. Due to its major regulatory impact on cell fate, the expression and activity of p53 in the cell is tightly regulated. p53 is redox regulated and the activities of antioxidant systems, such as the Trx system, have been linked to p53 functions. One study showed for instance that the deletion of the yeast orthologue of TrxR1 (*Trr1*) significantly impaired p53 activity [126]. Additionally, inhibition and modification of TrxR1 by lipid electrophiles in a mammalian cancer cell line caused conformational changes to p53 and impaired its function [127]. The cancer cells depleted of their TrxR1 were however less sensitive towards the electrophile-induced disruption of p53 [128]. Some of these results could partly be linked to the oxidation status and function of Trx. The DNA binding affinity of p53 is regulated via APE/Ref-1, which in turn needs to be reduced by Trx [129].

1.8.4 TrxR

TrxR is a homodimeric flavoprotein (FAD) (~ 110 kDa) belonging to the family of pyridine nucleotide-disulfide oxidoreductases [130,131]. Mammalian TrxR was originally purified from bovine and rat [89,119] and recognized to be a selenoprotein by Stadtman in 1995 [132,133,134]. The structure and the first part of the enzymatic reaction of mammalian TrxR is highly similar to GR, TrxR does however carry an extra 16 amino acid long C-terminal tail [135]. This C-terminal tail is flexible and includes the Sec-containing redox active motif, Gly-Cys-Sec-Gly, conserved in all mammalian TrxRs.

Comparing the human TXNRD1 gene with its mouse orthologue renders a conserved genomic organization and their cDNA sequences share ~ 80% homology [131,135]. TrxRs between higher and lower organisms, for instance in bacteria, yeast and plants differ substantially. The TrxRs in lower organisms are smaller (the dimer is ~70 kDa) and their substrate spectrum is narrower. The small form of TrxR1 also lack the Sec-residue and instead has a redox active dithiol [136].

1.8.4.1 Transcriptional regulation of TrxR1 expression

The transcriptional regulation of the mammalian gene encoding TrxR1 is very complex and involves alternative promoters and extensive alternative splicing [135,137,138]. The core-promoter of the gene has no TATA box, but instead DNA-binding sites for Oct-1, Sp1 and Sp3. Upstream of the core promoter there is a Nrf2 ARE binding motif and in the 3'UTR, downstream of SECIS, there are AU-rich elements. AU-rich elements are mRNA sequence elements rich in adenosine and uridine bases, mediating recognition of RNA binding proteins. These proteins can regulate splicing, stability or translation of mRNAs. AU-rich elements are generally found in transiently expressed genes, such as different transcription factors. The gene for TrxR1 contains 7 AU-rich motifs and deletion of these generally result in stabilization of the mRNA [139]. The mRNA binding and regulating proteins which have been shown to bind to the mRNA of TrxR1 are human antigen R (HuR) and tristetraprolin (TTP) [140,141].

1.8.4.2 Catalytic function

Mammalian TrxR is generally described as a dimeric enzyme arranged in a head to tail direction with active sites located in the N- and C-terminals (see Fig 4). The catalytic mechanism has been thoroughly studied and described [130,142,143,144]. The completely oxidized form of TrxR1 (E_{ox}) is in the first round reduced by one equivalent of NADPH. The FAD will accept the electrons, giving rise to a two electron reduced flavine ($FADH_2$). The N-terminal active site contains a redox active dithiol motif, Cys-Val-Asn-Val-Gly-Cys, to which the FAD will donate the electrons. One of electrons is transferred to Cys 59 and a charge-transfer complex is created between the FAD and Cys 64 (EH_2). This charge-transfer complex (EH_2) can be detected spectrophotometrically at a wavelength of 540 nm. The N-terminal redox motif of one subunit will subsequently shuttle the electrons to the C-terminal active site of the other subunit, giving rise to the selenolthiol. Upon reduction with a second equivalent of NADPH, a new thiolate-FAD charge-transfer complex can be formed, thus resulting in a four electron reduced enzyme species (EH_4). The four electron reduced enzyme species is believed to be the major form catalyzing substrate reduction. Reduction of Trx is mediated via the C-terminal selenolthiol

motif (of EH_4), giving rise to the two electron reduced enzyme with the thiolate-FAD charge-transfer complex (EH_2) and a selenenylsulfide. Upon reduction with another equivalent of NADPH, the four electron reduced enzyme can be recycled and reduce the next substrate. Important to note is that TrxR1 also has a Sec-independent inherent superoxide producing NADPH oxidase activity [145].

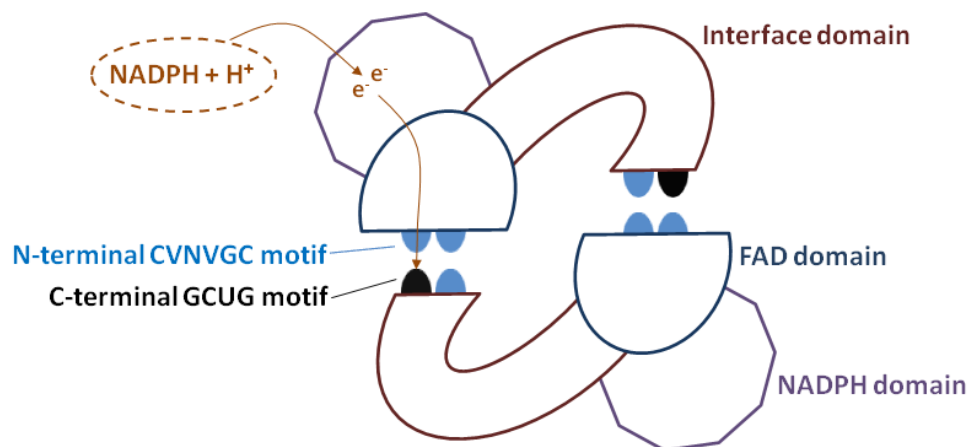

Fig 4. Overview of TrxR1 homodimer. The two enzyme subunits are arranged in a head-to-tail orientation where each subunit consists of three domains. TrxR1 has a dithiol (Cys 59 and Cys 64) catalytic motif in the N-terminal and the main catalytic motif located in the C-terminal and containing a selenothiol (Cys 497 and Sec 498).

1.8.4.3 Substrates of TrxR

With the Sec residue being surface exposed and very reactive, TrxR1 has broad substrate specificity. Beside Trx, which is regarded as the major cellular substrate, TrxR1 can reduce a number of low molecular weight compounds such as selenite [146] and methylseleninate [56], DTNB (5,5'-Dithio-bis(2-nitrobenzoic acid) [147], lipid hydrogen peroxides [148], lipoic acid [149], dehydroascorbate [150,151] and menadione (vitamin K3) [89]. Other protein substrates of TrxR1 are thioredoxin-related protein 14 (TRP14) [152,153], glutaredoxin 2 (Grx2) [84] and endoplasmic reticulum (ER) binding protein disulfide isomerase (PDI) [131].

1.8.4.4 TrxR inhibitors

Oxidized enzyme species, containing the selenenylsulfide bond between the C-terminal Cys and Sec is very resistant to modifications by electrophilic agents. The C-terminal selenolate is however very susceptible and easily targeted by electrophilic compounds. Irreversible Sec-derivatized TrxR1 enzyme species are no longer capable of reducing Trx or any other substrate requiring an intact C-terminus. Many inhibitors of TrxR1 have been published over the years and some of these are also clinically used [107,131,154,155]. Examples of typical TrxR inhibitors include: gold compounds (auranofin and aurothioglucose) used in the treatment of rheumatoid arthritis, ifosfamid [156,157], arsenic trioxide [158], platinum compounds [159] and nitrogen mustards (chlorambucil, melphalan) [160], which are all used in chemotherapy. Several naturally occurring agents, such as 4-HNE [161], different flavonoides [162,163] and isothiocyanates [162] are also efficient inhibitors of TrxR1. Some inhibitors, such as DNCB (1-chloro-2, 4-

dinitrobenzene) [163], curcumin [164] and juglone (5-hydroxy-1,4-naphthoquinone) [165], efficiently bind to and inhibit the C-terminal Sec of TrxR1 while also being capable of promoting maintained redox cycling with the inhibited enzyme and NADPH. The compounds can hence get reduced via FAD/ N-terminal dithiol-motif, strongly inducing the NADPH oxidase activity of TrxR1 and therefore converting the protein into a pro-oxidant ROS producer [166]. It is worth noting that the previously mentioned TrxR inhibitors, arsenic trioxide and auranofin, also have been shown to block general selenoprotein synthesis [167]. Electrophilic compounds utilized in the different papers included in this thesis are summarized in table I.

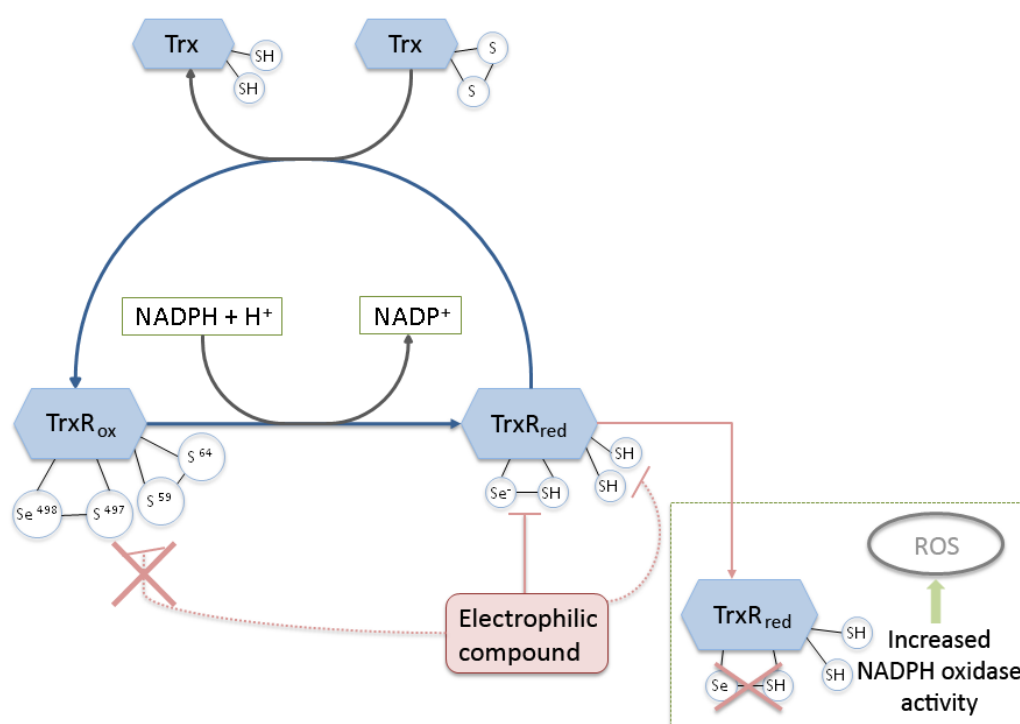

Fig 5. Schematic illustration of TrxR1 inhibition by electrophilic compounds. Many electrophilic drugs can specifically and irreversibly targeted the Sec-residue located in C-terminal active site, responsible for the reduction of Trx. Alternatively, both active sites can be targeted by electrophilic agents. If only the C-terminal motif is modified by the electrophilic agent and the N-terminal redox active motif remains intact, the NADPH-oxidase activity of the enzyme may become induced, hence giving rise to pro-oxidant enzyme species.

1.8.4.4.1 Cisplatin and other platinum drugs in relation to Trx system

cDDP was first synthesized by Peyrone in 1845, and its function as an inhibitor of cell division was discovered by Rosenberg in 1965 (see Fig 6) [168]. cDDP has been clinically used for more than 30 years and several different platinum compounds have been synthesized since then. Oxaliplatin (Oxa) (see fig 6) and carboplatin (*cis*-diammine-1,1-cyclobutane-dicarboxylatoplatinum(II)) are two other platinum anticancer drugs which are in clinical use today [169].

The molecular mechanism of cDDP was originally attributed to its ability to crosslink DNA. More recently, cDDP has been shown to cause extensive oxidative and nitrosative stress, which has a significant impact on its cytotoxicity [170].

cDDP and Oxa have been shown to efficiently inhibit TrxR1 *in vitro* [159,160]. Carboplatin, in contrast, could not inhibit the enzyme *in vitro*. cDDP is a platinum compound with two amine groups and two chlorides in the *cis*-orientation and upon administration cDDP undergoes non-enzymatic hydrolysis whereby the chlorine atoms bound to the platinum are replaced by water. The hydrolysed species are suggested to be the major cytotoxic forms [171,172]. cDDP is used to treat non-small cell lung cancer as well as bladder, ovary, testis, head and neck cancers. However, side effects such as renal insufficiency and ototoxicity limit the use. Increased ROS production is believed to play a central role in both cDDP-derived nephrotoxicity and ototoxicity [170,173]. cDDP accumulates rapidly in the kidneys cortex and mice treated with cDDP showed significant inhibition of TrxR [174,175]. The principle site of cDDP-derived toxicity in kidneys is the proximal straight tubule. In cochlea, the cDDP targets outer hair cells in the basal turn of the organ of Corti, cells of the stria vascularis and the spirial ganglion neurons [173]. cDDP and carboplatin have similar clinical profile but carboplatin is more stable and causes less severe side effects [176]. Oxa has another clinical profile and is used for treatment of colon cancer. Kidney and ototoxicity are both less common side effects of Oxa treatment.

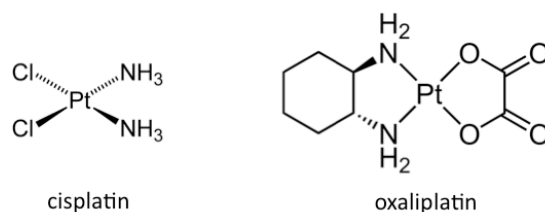

Fig 6. Structural Illustration of the platinum drugs cDDP and Oxa.

Increased expression and activity of Trx have been shown to correlate with increased cellular cDDP resistance and could therefore be a contributing factor [177,178]. In agreement with this, down-regulation of Trx by RNA interference enhanced cDDP-induced cytotoxicity [179]. Increased expression of TrxR1 does not necessarily cause protection and cellular resistance towards cDDP. Previously published results show that cDDP-derivatized TrxR1 species gain a new pro-oxidant function, capable of inducing cell death. cDDP-derivatized TrxR1 species have been named: selenium compromised thioredoxin reductase derived apoptotic proteins (SecTRAPs). SecTRAPs have a non-functional C-terminal active site, while the redox-function in FAD/ N-terminal dithiol-motif is maintained, thereby still having NADPH oxidase activity. The truncated form of TrxR1, lacking the last two amino acids (Sec-Gly), has been shown to have a similar activity [166].

Table I. Chemicals used in papers I-VI

Chemical	Effects on TrxR	Paper
Cisplatin (cDDP)	Inhibitor of TrxR and can generate SecTRAPs Crosslinks DNA and proteins. Increases cellular ROS levels	I, IV, VI
Oxaliplatin (Oxa)	Inhibitor of TrxR Forms DNA adducts	I, IV
DNCB (CDNB)	Inhibitor of TrxR and causes increased superoxide generating NADPH-oxidase activity	I
Auranofin	Inhibitor of TrxR Inhibits overall selenoprotein synthesis	I, II
Juglone 5-Hydroxy-1,4-naphthoquinone	Inhibitor of TrxR and causes increased superoxide generating NADPH-oxidase activity	I
Menadione 2-Methyl-1,4-naphthoquinone, Vitamin K ₃	Substrate of TrxR Can redox-cycle and causes oxidative stress and depletion of cellular GSH	I
Resveratrol 3,5,4'-trihydroxy-trans-stilbene	Weak inhibitor of TrxR. Activates Sirt1 activity	III
RITA (NSC 652287) 2,5-bis(5-hydroxymethyl-2-thienyl)Furan	Reversible inhibitor of TrxR. Targets p53 and prevent its interaction with Mdm2	II

2 AIMS OF THIS THESIS

The main aim of this thesis was to investigate the potential importance of TrxR1 as a target for anticancer therapy and its possible association with therapy related adverse side effects.

Specific objectives in papers I-VI were to:

- Explore the function and implications of high TrxR1 expression in cancer cells.
- Assess the molecular mechanism of TrxR inhibition by RITA.
- Investigate the molecular mechanism behind resveratrol-mediated inhibition of neural differentiation of neural stem cells (NSC) as well as to study the potential effects of wine and resveratrol on NSC and cancer cell survival.
- Elucidate pharmacokinetics and ototoxicity profile differences between the two platinum anticancer drugs cDDP and Oxa.
- Elucidate the role and importance of the two different electron donor systems based upon Trx and GSH for replicative potential in hepatocytes, thus *de novo* synthesis of dNTPs by RNR.
- Investigate whether targeting of TrxR1 by cDDP in kidneys is significant for the cDDP-induced adverse nephrotoxicity.

3 PRESENT INVESTIGATION

3.1 METHODOLOGY

Here follows a brief introduction to some of the methods used in *paper I-VI*. For more detailed information, see *Materials and methods* sections for each paper.

3.1.1 Cell cultures

For most cell-culture experiments described in *papers I-IV*, commercially available human cancer cell lines were used. The most frequently used cell lines were A549 lung carcinoma cells, colon cancer HCT116 cells, HCT116 *TP53*^{-/-} cells and neuroblastoma SH-SY5Y cells. Additionally, fibroblasts were used for experiments in *paper II*, and in *paper III* a major part of the experiments were performed using primary embryonic neural stem cells (NSCs) isolated from rat.

3.1.2 RNA silencing

In *papers I-III*, a widely applied RNA interference technique to induce silencing of gene expression was used [180]. Short double-stranded RNA molecules, 21 nucleotides long and referred to as small interference RNA or siRNA, were introduced by a transient delivering system. siRNA can induce a sequence-specific degradation of homologous mRNA sequences, subsequently causing a down-regulation of protein levels. However, the technique rarely results in a complete knockdown of target genes and there is a risk of off-target effects.

3.1.3 ⁷⁵Se radioisotope labeling

⁷⁵Se-labeling is a convenient and sensitive method for detecting Sec-incorporation into proteins. The method is very specific and only proteins having the UGA-codon together with a SECIS element will be radioactively labeled. This method was applied in *paper I* to determine the degree of siRNA-mediated knockdown of TrxR1 protein levels in cell cultures, by growing A549 cells in the presence of ⁷⁵Se-labeled selenite.

3.1.4 Measuring ROS

In *papers II and III* two different probes were used for detecting possible induction of ROS levels in cell cultures.

- 2,7-Dichlorodihydrofluorescein diacetate (DCF-DA) – mainly used as an indicator of peroxynitrite anions (ONOO⁻). Upon oxidation, the fluorescent molecule DCF is formed (*paper II*).
- Dihydroethidium – mainly used as a superoxide-indicator. Upon oxidation, ethidium is formed which can intercalate with DNA, resulting in a red fluorescent nucleus (*paper III*).

The specificity of these probes has been discussed quite extensively [181]. Questions such as sensitivity, marker specificity and probe-product reactivity should be considered carefully and taken into evaluation. Samples were analyzed by fluorescence-activated cell sorting (FACS).

3.1.5 Cell proliferation and viability assays

Depending on the material and desired readout, exposure to drugs was evaluated differently in *papers I-VI*. An overview to the methods used in *papers I-VI* is presented in table II. Samples were analyzed using normal light or fluorescence microscopy and for some of the applications, analyses were performed using FACS or a custom modified automated microscope system.

Table II. Methods applied to assess cell viability and growth.

Method	Staining mechanism	Paper
SubG1 Propidium iodide (PI)	Stains DNA and can be used to distinguish necrotic and apoptotic cells from each other. Can also be used for DNA content in cell cycle analysis.	I, II
Vital Dye	Assay based on plasma membrane integrity, a mixture of dyes detecting live and dead cells. Analyses were automated.	I
Annexin V Fluorescently labeled with FITC	Annexin V is a protein preferentially binding to Phosphatidylserin and thereby stains apoptotic cells.	III
DAPI Hoechst 33342	Stains DNA of living and dying cells. Detecting morphological changes.	III
Apoptosens	Measuring DEVDase activity by detecting caspase-cleaved keratin 18.	IV
anti-PCNA Proliferating cell nuclear antigen	Antibody detecting PCNA, synthesized mainly in G1 and S phase.	V
anti-PHH3 Phosphorylated histone H3	Antibody detecting PHH3, a marker for late G2 and M phase.	V
anti-BrdU 5-bromo-2'-deoxy-uridine	BrdU can be incorporated into DNA, which then can be detected with an antibody towards BrdU.	V
TUNEL	Catalytic incorporation of fluorescein-12-dUTP at 3'-OH DNA ends.	VI
H&E Hematoxyline & eosin	Hematoxylin is a basic dye staining the nuclei. Eosin is a acid dye staining the cytoplasm.	VI

3.1.6 Measuring enzyme activity

3.1.6.1 Trx and TrxR activity assay

Enzyme activity assays were performed on cell- or tissue lysates in *paper I-VI*. To measure total activity of Trx or TrxR, a previously developed endpoint insulin assay was applied [147]. The assay can be used for determination of either Trx or TrxR activity, using a relative excess of one of the proteins. The assay is based upon the fact that Trx is rapidly oxidized by insulin and TrxRs are the only enzymes known to reduce Trx. Appropriate amounts of samples were incubated at 37°C with NADPH, excess amounts of insulin and recombinant human Trx1 or rat

TrxR1. To stop the enzymatic reaction, a high concentration guanidine hydrochloride (GuHCl) solution is added to the reaction mixture. The GuHCl solution also contains DTNB, hence the number TNB anions formed will reflect the number of Trx-dependent insulin thiols in the reaction. The activity is determined by spectrophotometric measurements at 412 nm (TNB $\epsilon = 13.600 \text{ M}^{-1} \text{ cm}^{-1}$). A background absorbance reference was included for each sample. It should be noted that with the herein described standard assay it is not possible to distinguish between TrxR1 and TrxR2, and the activity is therefore always referred to as total TrxR activity.

3.1.6.2 GR and GST activity assay

Glutathione reductase (GR) activity was measured by detecting the NADPH-dependent reduction of oxidized glutathione (GSSG) at 340 nm (NADPH $\epsilon = 6200 \text{ M}^{-1} \text{ cm}^{-1}$) in *paper I* [182]. Glutathione S-transferase (GST) activity was measured in *paper VI* using DNCB, which is a substrate for a broad range of GSTs. GST catalyze the conjugation of GSH to DNCB, the product formation can then be monitored as a change in absorbance at 340 nm [183,184].

3.1.6.3 GSH depletion and total GSH+GSSG levels determination

L-Buthionine-SR-sulphoximine (BSO) is a potent inhibitor of γ -GCS and thereby inhibits the GSH synthesis and was therefore used to deplete cellular levels of GSH in *papers I and V*. Total levels of GSH, not distinguishing between the reduced and oxidized form, was quantified according to the GR-DTNB recycling assay [185].

3.1.6.4 Recombinant protein assay

Standard *in vitro* assays with recombinant rat TrxR1 enzyme, used in *paper II and III*, were the DTNB (5,5'-dithio-bis(2-nitrobenzoic acid)) assay and the insulin-coupled Trx assay [147]. DTNB is a direct substrate of TrxR, which is reduced to two TNB anions and can be detected at 412 nm. DTNB can be reduced both at the C-terminal active site (95% of the substrate molecules) and to a small part also via the FAD/N-terminal dithiol-motif (5%). In the Trx assay, the NADPH consumption is detected at 340 nm and the assay reflects possible changes, e.g. inhibition, to both TrxR and Trx. The Trx is only reduced through the C-terminal active site of TrxR.

3.1.7 Guinea pig model for inner ear studies

A guinea pig model was used to study differences between cDDP and Oxa in pharmacokinetics and cochlear hair cell toxicity in *paper IV*. This system is a well-established model for studying cochlear effects of ototoxic drugs since structure and hearing range of the guinea pig ear is similar to that of humans [186].

3.1.8 The Cre/LoxP recombination systems

Homozygous inactivation of the *Txnrd1* gene results in embryonic lethality. However, the Cre/LoxP inducible site-specific recombination technology makes it possible to circumvent this problem and assess the *Txnrd1* gene function in adult mice. The Cre/LoxP system enables site-specific DNA recombination of LoxP flanked chromosomal DNA sequences [187]. With the Cre/LoxP technology it is therefore possible to generate tissue-specific knockouts and it also allows genetic

disruption of the target gene under specific conditions. Hence, in *paper V and VI* an already established conditional *Txnrd1* knockout mouse model was used [99,102,103]. The conditional *Txnrd1* knockout mice are born as functional wild type animals. It is first upon the expression of Cre recombinase as the first two exons from the *Txnrd1* gene are excised [99]. The first two exons of the *Txnrd1* gene are placed between two LoxP sites (see fig 7). mRNA is still issued from the *Txnrd1* null allele, but these mRNA molecules are not engaged by ribosomes and will therefore not be translated. Furthermore, to be able to distinguish cells with active Cre, the *Txnrd1* conditional knockout mice also have a two-color Cre-responsive reporter gene (*ROSA^{mT-mG}*) (see fig 7) [188]. Accordingly, generated *Txnrd1* null cells will turn green-fluorescent while cells without conversion remain red-fluorescent. It should here be noted that the intracellular protein status of Cre-targeted cells will also depend upon the half-life of TrxR1 and the fluorescent proteins.

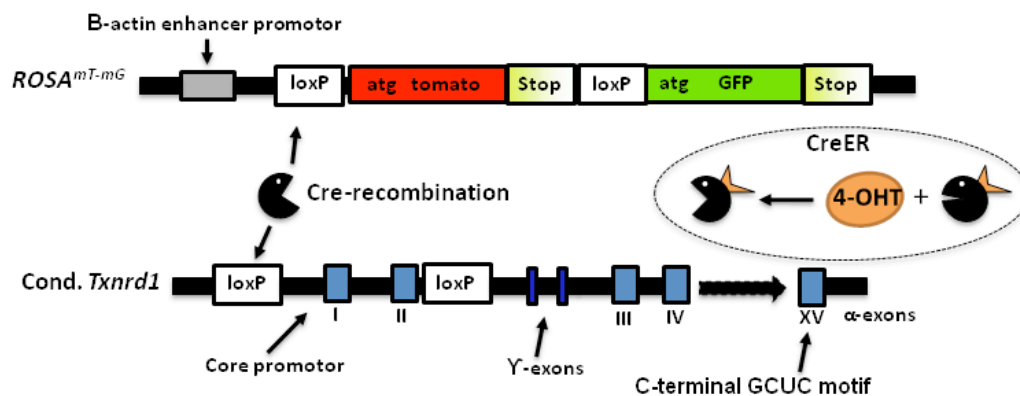

Fig 7. Schematic illustration of Cre recombination of the *ROSA^{mT-mG}* allele and *Txnrd1* conditional allele. The β -actin enhancer enhances expression of the ROSA26 promoter, driving strong expression of a membrane-targeted version of the tdTomato (mT). The *ROSA^{mT-mG}* mouse have Cre recognizable loxP sites on both sides of the mT cassette and upon Cre expression the mT cassette is deleted, allowing expression of membrane tagged GFP instead. Concerning the *Txnrd1* conditional allele, the Cre excises exons I and II, including the ATG start codon and the N-terminal redox-motif

Mice with a hepatocyte specific Cre expression were used in *paper V* to knockout *Txnrd1*. The Cre expression is here under the control of the albumin promoter (*AlbCre*), consequently giving a hepatocyte specific gene inactivation [189]. A tissue specific knockdown may be preferable to complete knockouts, since total knockout of a gene could be embryonic lethal or lead to a very complex phenotype and thereby making results difficult to interpret. The negative aspect is however having a constantly active Cre, which potentially can have affects on cellular function. In *paper VI*, mice ubiquitously expressing an inducible form of Cre in all tissues were also used. The Cre gene has in this case been fused to a mutant form of the ligand binding domain of the estrogen receptor (CreER) [190]. Hence the mutant receptor binds tamoxifen or 4-hydroxytamoxifen (4-OHT), but not estradiol. In its inactive form, CreER is retained in the cytosol, but when CreER binds 4-OHT, CreER translocates to the nucleus. The activation of Cre will give

rise to cell-specific deletion of genes, creating a mosaic mouse having both *Txnrd1* null and non-converted *Txnrd1*-containing cells in all tissues. An advantage with CreER mice is the inducibility of Cre recombination expressed in all tissues. On the other hand, depending on local concentrations of 4-OHT, the conversion efficiency could differ substantially between animals, as well as between different tissues in a single animal. Furthermore, the 4-OHT exposure can in itself potentially have effects on the animal. The different mouse models used in *paper V and VI* are summarized in table III.

Table III. *Txnrd1* status in liver and kidney of the different mouse models used in paper V and VI.

Mouse strain	<i>Txnrd1</i> status	
	Liver	Kidney
C57BL/6J wild types	+/+	+/+
Mosaics after 4-OHT <i>Txnrd1 cond/cond</i>	+/+ and -/-	+/+ and -/-
<i>AlbCre controls</i>	+/+	+/+
<i>Txnrd1 cond/null AlbCre</i>	-/-	+/-
<i>Txnrd1 cond/+ AlbCre</i>	+/-	+/+

3.2 RESULTS AND CONCLUSIONS

3.2.1 Paper I

Eriksson SE, Prast-Nielsen S, Flaberg E, Szekely L, Arnér ES. High levels of thioredoxin reductase 1 modulate drug-specific cytotoxic efficacy.

The Trx-system has been shown to be over-expressed in many tumors and cancer cell lines [104,191]. Hence, the aim of this study was to further investigate the role of high TrxR1 expression in cancer cells. To study this, siRNA was utilized to transiently down-regulate the levels of TrxR1 in a human lung cancer cell line (A549), which is known to express very high levels of both TrxR1 and Trx1 (www.proteinatlas.org). A549 cells have previously been shown to harbor a mutation in the Keap1 gene, leading to a constitutive activation of the Nrf2 pathway, which might explaining the high expression levels of TrxR and Trx [35].

In this study it was found that down-regulation of TrxR1 levels to ~ 10% of the original levels had no apparent effect on the cell growth or on cell cycle distribution. Even if the TrxR1 deficient A549 cells were subjected to GSH depletion there was hardly any effect on the cell viability or on the cell growth after 72 h. By growing cells in the presence of BSO, the total cellular GSH+GSSG pool was decreased by 98 %. The lack of distinct phenotypic effects after knockdown, with and without GSH depletion, indicated that the remaining TrxR activity was enough to sustain the activity of Trx, and subsequently for example support DNA synthesis. The TrxR activity remaining in TrxR1 siRNA-mediated knockdown cells were in the same range as the activity in measured tissue extracts from normal mouse liver or kidney (see paper V and VI).

The TrxR1 activity originally measured in the A549 cells, grown in the presence of 25 nM selenite, was substantially higher than the measured Trx activity, suggesting that TrxR1 might have other cellular functions as well, or (less likely) not being used at all. Furthermore, it was investigated whether A549 cells, after transiently lowering the levels of TrxR1, showed different toxicity profiles towards a set of compounds typical known to interact or target TrxR1. The resulting drug sensitivity assays showed a multifaceted picture. A549 cells with the endogenous high expression of TrxR1 were less sensitive towards DNCB and menadione compared to the siRNA treated cells. There was however no difference in sensitivity detected towards auranofin or juglone. Interestingly, cells with high expression of TrxR1 were more sensitive towards cDDP. The increased sensitivity towards cDDP-derived damage in cells overexpressing TrxR1 can be explained by earlier published data, which shows that cDDP derivatized TrxR1 protein species can gain a new and pro-oxidant function in a cellular system [166].

3.2.2 Paper II

Hedström E, **Eriksson S**, Zawacka-Pankau J, Arnér ES, Selivanova G. p53-dependent inhibition of TrxR1 contributes to the tumor-specific induction of apoptosis by RITA.

Inactivation of p53 is one of the most frequent alterations in a tumor cell [192,193]. This can be achieved either by direct mutation of the *TP53* gene or via the up-regulation of its negative regulators. p53 is a key regulator of cell fate upon cellular damage. The p53 pathway is therefore seen as a prime target in the development of new chemotherapeutic drugs. Pharmacological approaches of reactivating the tumor suppressor functions of wild-type p53 could be a very efficient and valuable strategy in anticancer therapy [194]. Several p53-targeting low molecular weight compounds have been shown to efficiently inhibit tumor growth. RITA (reactivation of p53 and induction of tumor cell apoptosis, NSC 652287) is one example of such a compound, proposed to bind to the N-terminal domain of p53, thereby blocking interactions with its negative regulators, such as the ubiquitin ligase Mdm2 [195]. p53 is a redox regulated transcription factor, hence several connections have been made between the Trx-system and p53 [127,129,196]. In the light of these earlier findings, the aim of paper II was to further explore the molecular mechanism of RITA and investigate if TrxR1 could be an additional target of RITA.

In this study, it was shown that RITA binds non-covalently to TrxR1 and inhibits its activity *in vitro*. Even more interesting was that HCT116 tumor cells exposed to RITA showed, together with a reduced cellular TrxR activity, induced formation of a stable high molecular weight form of TrxR1. This high molecular form of TrxR1 was detected upon immunoblotting and was not observed upon exposure to auranofin, which is a very efficient inhibitor of TrxR. It was also seen that siRNA-mediated knockdown of TrxR1 eliminated the high molecular weight TrxR1 form. Mass spectrometry (MS) analysis confirmed that the high molecular form of TrxR1 was a covalently linked dimer. The TrxR1-dimer was also ⁷⁵Se-labeled. Nevertheless, the covalently linked dimer could not be detected *in vitro*, using incubation of RITA with purified recombinant TrxR1. However, it has been proposed that RITA could become metabolized to more reactive species, which are capable of binding covalently to different cellular targets. The metabolism of RITA into more reactive metabolites can thus be one explanation to why the dimer of TrxR1 was not formed upon incubation *in vitro* with intact RITA [197].

Furthermore, cells treated with RITA showed induced cellular ROS levels, which were correlating with the formation of the TrxR1-dimer and the subsequent induction of cell death. The increased ROS production was also p53-dependent. HCT116 *TP53*^{-/-} cells exposed to RITA showed no increase in ROS production, less TrxR inhibition, and had only minor amounts of the TrxR1-dimer as compared to the HCT116 wild type cells. Cells exposed to auranofin also showed increased ROS production and cell death, although the effects could not be correlated to covalently linked TrxR1-dimer. Additionally, fibroblasts treated with RITA showed increased total TrxR activity and there was no increase in ROS production.

3.2.3 Paper III

Wallenborg K, Vlachos P, **Eriksson S**, Huijbregts L, Arnér ES, Joseph B, Hermanson O. Red wine triggers cell death and thioredoxin reductase inhibition: effects beyond resveratrol and SIRT1.

Moderate consumption of red wine has long been postulated to have positive health effects [198]. Red wine contains a cocktail of polyphenols and many of these have antioxidant properties [68]. Resveratrol is one of these polyphenols and several studies have speculated that resveratrol could be responsible for some (or most) of the beneficial health effects of red wine. Resveratrol has for example been suggested to be a cancer chemopreventive agent. The aims of paper III were to investigate potential effects of wine and resveratrol on neural stem cells (NSC) and cancer cell survival. Furthermore, it was assessed whether resveratrol-mediated effects on NSC and cancer cells were dependent on SIRT1 activity. SIRT1 is a NAD⁺-dependent class III histone deacetylase, important for many cellular processes including gene silencing, regulation of p53 and NF-κB activity [199]. It was discovered that low concentrations (0.5-3 μM) of resveratrol inhibited neural but not astroglia differentiation of NSC via a SIRT1-dependent mechanism. These results indicate that SIRT1 could act as a repressor of neural differentiation.

Resveratrol at higher concentrations (≥10 μM), however, induced NSC and neuroblastoma cell death independent of the cellular SIRT1 status. Furthermore, NSC and various cancer cell lines exposed to red wine (1-5 % v/v) showed a rapid onset of cell death. White wine on the other hand, at the same concentrations, had no effects on the cell viability. This red wine-induced cell death was also shown to be independent of ethanol, SIRT1 and resveratrol and was instead associated with increased oxidative stress and inhibition of cellular TrxR activity.

Inhibition studies using recombinant TrxR1 showed that the inhibition potential of red wine could be correlated to the increase in absorbance at 520 nm, and therefore linked to the color compounds in wine. Incubating recombinant TrxR1 with resveratrol resulted in a weak enzyme inhibition (< 20%) and no inhibition was detected in a cellular system. Wine is a complex mixture of many different substances, for instance polyphenols, such as resveratrol and tannins, and flavonoids, such as quercetin, myricetin and anthocyanins, several being important for giving wine its color. Many of these compounds are mainly found in the skin of grapes, depending on the vinification process and the grapes used, the concentration of these will therefore vary. Two flavonoids which can be found in wine, quercetin and myricetin, are known to irreversibly inhibit TrxR1 [200]. Red wine dependent inhibition of TrxR is however most likely an additive effect of several molecules.

Although red wine as such is unlikely to reach TrxR1 in cancer cells, this study showed that *i)* red wine contains substances other than resveratrol that have strong effects on cells, and *ii)* some of those compounds are efficient inhibitors of TrxR1.

3.2.4 Paper IV

Hellberg V, Wallin I, **Eriksson S**, Hernlund E, Jerremalm E, Berndtsson M, Eksborg S, Arnér ES, Shoshan M, Ehrsson H, Laurell G. Cisplatin and oxaliplatin toxicity: importance of cochlear kinetics as a determinant for ototoxicity.

Ototoxicity is a dose-limiting side effect of cDDP treatment. cDDP targets all sub-regions of the cochlea and the cDDP-induced hearing loss is usually irreversible [201]. Oxa is another platinum compound used in chemotherapy, which has a different clinical profile and ototoxic side effects are rarely observed. Both compounds have previously been shown to inhibit TrxR1 *in vitro*, and Oxa was shown to be the most efficient inhibitor of TrxR1 [159]. The aims of paper IV were to elucidate the differences in toxicity profile and pharmacokinetics between these two platinum anticancer drugs. It was discovered that the cochlear uptake of Oxa was lower than for cDDP, this being most likely the main explanatory factor to why Oxa does not cause ototoxicity to the same extent as cDDP. Inner ear studies were performed in guinea pigs, which were also shown to express TrxR1 in the organ of Corti.

cDDP and Oxa showed similar levels of apoptosis induction in HCT116 cells. Pre-treatment of cells with a superoxide scavenger (Tiron), or a calcium chelator (BAPTA-AM), reduced the cDDP-induced apoptosis while pre-incubation with Tiron or BAPTA-AM had no effect on Oxa-induced apoptosis. Furthermore, HCT116 cells incubated with 20 μ M cDDP showed inhibition of total TrxR activity, which was not seen after similar treatment with Oxa in the HCT116 cells. Hence, cDDP and Oxa induce cell death through different pathways. cDDP treatment causes increased levels of ROS and induced cell death, which is partly nucleus-independent. Since the hair cells in cochlea are terminally differentiated, DNA independent derived toxicity may perhaps be more crucial.

3.2.5 Paper V

Prigge JR, **Eriksson S**, Iverson SV, Meade TA, Capecchi MR, Arnér ES, Schmidt EE. Hepatocyte DNA replication in growing liver requires either glutathione or a single allele of *Txnrd1*.

RNR sustains the cellular homeostasis of nucleotides by catalyzing the rate-limiting *de novo* synthesis of 2'-deoxyribonucleotides (dNTP) from the corresponding ribonucleotides [72,73]. The redox active cysteine residues in RNR can be reduced by either Grx or Trx [74,75,76]. Previous studies have shown that *Txnrd1* null/null hepatocytes can replicate normally [103]. Hence, the aims of this study were to explore the role of the two different electron donor systems, Grx and Trx, for hepatocyte replicative potential and thus *de novo* synthesis of dNTPs by RNR.

The mitochondrial TrxR2 has also been shown to catalyze the reduction of cytosolic Trx1. Therefore it was previously proposed that there could be different splice forms of TrxR2 in the cytosol, potentially capable of supplying reducing equivalents to Trx1 [202]. It was therefore investigated whether these potential cytosolic mRNA forms of TrxR2 exist in mammalian hepatocytes. To approach these questions inducible Cre/loxP mediated tissue-specific hepatocyte *Txnrd1*-knockouts were used.

Results from this study show that *Txnrd1* null/null livers had a ~75 % reduction in total TrxR activity as compared to wild types. The remaining TrxR activity most likely derives from TrxR2 and the non-hepatocytic cell fraction present in liver. There was virtually no expression of the TrxR2 mRNA cytosolic splice forms, neither in normal nor in *Txnrd1* null/null livers, suggesting that TrxR2 is unlikely to compensate for the loss of TrxR1 in this system. Furthermore, wild type mice or mice heterozygous for the *Txnrd1* gene, subjected to GSH depletion by BSO treatment, showed no effect on hepatocyte replication index. The replicative potential was only affected in *Txnrd1* null/null livers of mice treated with BSO, which show a significant decrease in replication. These results show that the Trx-system and GSH-system act in a complementary fashion, and can independently from each other support hepatocyte proliferation by delivering electrons to RNR. The requirement of nucleotides varies between different cell types, and the accessibility of reducing equivalents from either the GSH or Trx system might also differ depending on the cellular situation or on the cell type. This is the first mammalian *in vivo* model studying the role of the two different RNR electron providers in relation to DNA replicative potential in hepatocytes.

3.2.6 Paper VI

Eriksson S, Iverson SV, Prigge JR, Capecchi MR, Arnér ES, Schmidt EE. Thioredoxin reductase 1 status in liver and kidney influences the extent of nephrotoxicity triggered by cisplatin. *Manuscript*.

cDDP is a widely used anticancer drug displaying nephrotoxicity as a major dose-limiting side effect. The mechanism of cDDP-derived nephrotoxicity is not yet entirely understood and damage is primarily located to the proximal tubule cells. However, oxidative stress has been shown to be an important factor for the derived toxicity [170,203]. TrxR1 is a known cDDP-target, thus the aim of the present study was to investigate whether the targeting of TrxR1 by cDDP in kidneys is significant for cDDP-induced adverse effects. To evaluate this hypothesis inducible Cre/loxP mediated conditional *Txnrd1* knockout mice were used.

The cDDP-induced kidney toxicity was first studied in a 4-OHT induced CreER mosaic mice, having both *Txnrd1* null and wild type *Txnrd1* containing cells in all tissues. Secondly, to investigate whether changes in liver xenobiotic metabolism, as a result of TrxR1 deficiency and Nrf2-activation [102], could affect the outcome of cDDP-derived nephrotoxicity, *AlbCre* hepatocyte-specific *Txnrd1* knockout mice were used. Both mosaics and tissue-specific *Txnrd1* knockouts express a two color Cre-responsive reporter gene (ROSA^{mT-mG}).

Animals were intraperitoneal injected with either cDDP or saline. Hepatocyte-specific *Txnrd1* knockout mice and the *AlbCre* control mice had a significantly higher TrxR1 activity in kidney compared to both mosaics and wild type animals. *AlbCre* animals showed in general more cDDP-induced kidney damage as compared to wild type controls. There seems to be a difference in cDDP-induced pathology between the different mouse models, which most likely can be explained by the TrxR1-status in the kidneys. Mosaic mice were also more susceptible towards cDDP-induced nephrotoxicity as compared to wild types. Interestingly TrxR enzyme activity in total kidney was not altered between mosaics and wild types. Results showed, however, that mosaic animals had reduced levels of TrxR activity in the liver as compared to wild types, which could be correlated to the degree of kidney injury. The results from immunohistochemistry on kidney using a TrxR1 antibody revealed that mosaics, compared to wild type animals, had a more heterogeneous expression pattern of TrxR1. Thus the *Txnrd1* genetic conversion in mosaic kidneys seems to have given null cells in parallel with compensatory increased levels of TrxR1 in other cells, and the compensatory effect was even more apparent after cDDP treatment. Results presented in manuscript VI reveals a complex mechanism and the major conclusions drawn from the current data suggests that a *Txnrd1* genetic deficiency in liver together with high expression levels of TrxR1 in kidney increase the susceptibility to cDDP-induced kidney damage.

Yet, to be truly able to draw conclusion from the data presented, there is a need to further assess and validate the data. There are a number of confounding factors that need to be further evaluated:

- The selenium status in mice. There is significant difference in the total TrxR activity in kidney between the wild types and AlbCre control animals. Differences in dietary selenium status could be one plausible explanation to variations in enzyme activity [52].
- Gender differences. To correct for this factor several animals will be needed in future experiments [204,205].
- Potential limitations in the Cre-mediated gene inactivation approach. Possible adverse effects from the 4-OHT administrations and the potential impact of the Cre-expression *per se* needs to be ruled out [190,206].

Furthermore, to be able to draw conclusions from the kidney histology of the mosaic model, there is a need to securely identify what cell types that are converted as well as being damaged by the cDDP-treatment the existing mosaic models.

4 DISCUSSION AND FUTURE PERSPECTIVE

The main objective of this thesis was to explore the role of TrxR1 as a drug target and its significance for chemotherapy derived side effects. The effect of TrxR1 targeting was shown to be drug-specific and dependent on the cellular levels of TrxR1.

In *paper I*, the effects of siRNA-mediated TrxR1 knockdown in a cancer cell line (A549), normally overexpressing TrxR1, was investigated. The TrxR1-deficient cancer cells showed no effects on cell growth or viability and they were shown to be insensitive to GSH depletion. The total TrxR activity remaining in the deficient cells was ~ 10% of that found in the control cells. Protein analysis by MS indicated that most of the remaining TrxR activity in TrxR1-deficient cells was due to TrxR1, and not because of TrxR2 as originally thought. Hypothetical calculations, as to the DNA synthesis potential, imply that the activity still remaining in TrxR1-deficient cells would be enough reducing power to sustain the Trx-related functions in the cell. Results from *in vivo* experiments presented in *paper V* support this notion. In this paper it was shown that the total TrxR activity measured in the extracts from wild type mice was comparable to the total activity measured in TrxR1-deficient cancer cells.

In addition, it was also shown that siRNA-mediated TrxR1 knockdown in cancer cells caused increased sensitivity towards the typical oxidative stress inducing agents menadione and DNCB. Interestingly, the TrxR1 deficient cells were found to be more resistant towards cDDP treatment. These results go well together with previously reported data, which show that cDDP alkylated TrxR1 potentially can gain a new and pro-oxidant function in cancer cells (SecTRAP) [166]. cDDP treatment could also result in covalently linked complexes of TrxR together with either Trx or TRP14 [207]. These complexes were also recently detected in kidney and liver extracts from cDDP treated mice (*unpublished results*). The mechanism for producing the complexes and their potentially cellular function is currently under investigation. Furthermore, recent experiments from our lab, with recombinantly produced proteins, show that the Sec to Cys mutant of TrxR1 is not as easily inhibited by cDDP. In cell culture experiments, where the formation of the Sec to Cys variant of TrxR1 was induced by growing cells in the presence of thiophosphate, the cytotoxicity towards cDDP was reduced (*submitted manuscript Peng et al*).

As described above, the A549 cancer cell line used in *paper I* had ~ 10 times more TrxR activity as compared to normal liver or kidney, hence these cells seem to have large overcapacity and the function of overexpressed TrxR1 protein has not been fully elucidated. Is the sole effect of the extra enzyme species to serve as a backup or are there other dedicated substrates in need of reducing equivalents? TrxR1 has been shown to have broad substrate specificity *in vitro*, reducing not only Trx, but also other proteins and low molecular weight substances. TRP14 is a quite recently discovered protein shown to be a substrate of TrxR1 and the functions of this protein are still largely unknown [152,153,208]. Recent unpublished results from our group show that the efficiency of TRP14 reduction by TrxR1 is similar to the activity with Trx. These results however need to be confirmed, enzymatic properties of TRP14 are currently being characterized. TrxR has also been implicated to play a role in mammalian selenium metabolism by reducing different selenium species into selenide (Se^{2-}), which subsequently can be used for selenophosphate synthesis [56,209]. To further study the role of TrxR1 in selenium metabolism and homeostasis, the different *Txnrd1* knockout mouse models utilized in *papers V and VI* could become valuable tools.

In *paper II* it was demonstrated that RITA could cause increased levels of ROS and inhibition of TrxR activity, in a p53-dependent manner. *In vitro*, RITA was found to be a reversible inhibitor of TrxR1. Nonetheless, RITA treatment of cancer cells gave a covalently linked TrxR1-dimer. It has been suggested that RITA is metabolized to more reactive species capable of covalently linking different cellular targets, hence potentially explaining this phenomenon [197,210]. The dimerization however, seems to only occur with a fraction of the cellular TrxR1 protein, correlating with the RITA-induced ROS production. The dimerization could be a result of increased ROS levels confined to specific subcellular areas, where ROS directly or indirectly might effect the function of TrxR1 [20,211]. We recently discovered that RITA induced apoptosis as well as the covalent TrxR1 dimerization, could be prevented by pre-incubating cells with nordihydroguaiaretic acid (NDGA). NDGA is a lipoxygenase inhibitor having ROS scavenging capacity [212]. Ongoing studies are aiming to elucidate the mechanism behind the covalent TrxR1-dimerization.

In *paper III* it was shown that red wine but not white wine could inhibit the TrxR activity, both *in vitro* and in cell cultures. Red wine contains a complex mixture of polyphenols and flavonoids, many of these could potentially affect the function of TrxR. Isolating naturally occurring inhibitors could be a beneficial strategy to find new drug candidates, which potentially would possess less toxic side effects. However, fractionation and identification of different phenolic compounds and flavonoids in red wine is a time-consuming and difficult task. A more efficient alternative to characterize new candidates of TrxR1 inhibitors and substrates, is to use small molecule libraries for high-throughput biochemical drug-screenings [213].

Cochlea and kidney related side effects from cDDP treatment have been linked to increased ROS production [173,201,214]. Thus, the aims of *papers IV* and *VI* were to explore the pharmacological targeting of TrxR1 by cDDP and its potential role in adverse side effects. In *paper IV* it was shown that cDDP, but not Oxa, induced cell death that involved increased ROS production, which should be of major importance for inducing damage in terminally differentiated cells, such as cochlear hair cells. Most importantly, it was here shown that the cochlear uptake of Oxa compared to cDDP was lower, likely explaining why Oxa only rarely cause hearing loss. Results showed that TrxR1 is expressed in cochlea, however, the potential correlation to degree of cDDP-induced damage has not yet been evaluated. The mosaic mouse models, having both *Txnrd1*-deficient and *Txnrd1*-containing cells in all tissues, could potentially be utilized for evaluating the significance of TrxR1 in cochlea. Studying ototoxicity in mice could become technically challenging due to their fast metabolic rate, making them less sensitive towards the cDDP-derived ototoxic side effects, and their small size [186].

cDDP treatment has previously been shown to affect the TrxR activity in kidney and to be associated to the degree of damage [156]. In *paper VI* it was shown that the expression level of TrxR1 affected the degree of cDDP-induced renal damage. The degree of damage appeared not only to be dependent on the TrxR status in kidney, but also on the status in liver, making the output data rather complex and challenging to interpret. At this point, further analyses and more control experiments are still required to securely interpret the data and to identify the mechanism. cDDP treatment is suggested to primarily damage proximal tubule cells, thus it could be of interest to generate a proximal tubule specific *Txnrd1* knockout, and there are already several mouse strains with kidney specific expression of Cre established [215].

In *paper V* it was shown that either the GSH-system or the TrxR1-dependent pathway, independently of each other, were able to support proliferation of hepatocytes. Furthermore, having only one functional *Txnrd1* allele was still sufficient to sustaining the proliferation. Only livers from *Txnrd1* null animals treated with BSO showed reduced DNA replication and none of these animals showed any signs of general effect on cell survival. Previous results from animals with *Txnrd1* null livers showed chronic transcriptional induction of Nrf2 regulated genes [102]. Elevated Nrf2 transcriptional activity has also been described for γ -GCS knockout mice, while GSH-depletion in itself does not trigger Nrf2 activation [216,217]. The redox state of Trx has not been evaluated in the *Txnrd1* null livers and since TrxRs are so far the only enzymes known to reduce Trx, evaluating the redox state of Trx could potentially be of high interest. Previous results from cancer cells with a transient siRNA mediated knockdown of TrxR1, showed no changes to cellular Trx redox state [218]. However, these cells also had a significant residual TrxR activity (*see paper I*), which could be enough for keeping Trx in a reduced state under non-stressing conditions. The mammalian Trx and GSH systems are clearly complementary to each other, but if and how they crosstalk in different mammalian cells and tissues has not been completely elucidated and will take much effort to fully characterize.

The requirement for producing DNA precursors varies depending on cell type. Additionally, increased levels of ROS have been shown to diminish cellular dNTP pools [219]. Induced dNTP production and oxidative stress is a common attribute of cancer cells. Simultaneous inhibition of two major antioxidant systems, the Trx- and the GSH-system, will disturb the cellular redox balance and impair the dNTP synthesis, and could be a efficient strategy for killing tumor cells. It was recently shown that *Txnrd1* null tumor established in mice, were highly susceptible towards BSO treatment and the subsequent GSH depletion [110].

TrxR1 appears to have an important role in preventing tumor development, but it seems to be a double-edged sword as it also has a role in promoting cancer under certain conditions. TrxR1 and Trx have both been shown to be highly expressed in tumors and have been proposed as promising targets for anticancer therapy. However, the targeting of TrxR1 could also be important for, and associated with, certain chemotherapy-derived side effects. The picture gets even more complicated by TrxR1 having a number of splice variants with still unknown tissue distribution and functions. The role of TrxR1 in general and its importance in tumor cells is still far from being fully understood. The role and targeting of TrxR1 should therefore be further explored. Acquired knowledge could in the future form the basis for improved therapeutic function of anticancer therapy and decrease the risks for associated side effects.

Based upon the results from the studies described in this thesis and the discussion above, the following experiments/studies could be a potential next step in order to improve understanding of the role(s) of TrxR in cancer therapy:

- The highly interesting data collected and presented in *paper VI* promote further investigation of the role of TrxR1 in cDDP-derived toxicity. Generating proximal tubule specific knockouts of *Txnrd1* would be a useful tool to study this.

- Determining the mechanism behind the RITA-induced covalently linked TrxR1-dimer and the cDDP-induced TrxR-TRP14/Trx complexes. MS-based techniques could be used to analyze the protein complexes and results could potentially provide clues about mechanism and function. Furthermore, radioactively labeled RITA could be used to investigate if RITA metabolites can potentially covalently link TrxR1.
- The knockout mouse models with conditional expression of TrxR1 described in this thesis could form the basis for studying the role of TrxR1 during tumor initiation/formation and progression.
- By utilizing the hepatocyte specific *Txnrd1* knockout mouse, the functions of Trx system in relation to selenium metabolism (and selenium toxicity), could potentially be clarified.

5 ACKNOWLEDGEMENTS

The work on this thesis was performed at the Division of Biochemistry, Department of Medical Biochemistry and Biophysics, Karolinska Institutet.

For the last ten years I have been studying at Karolinska Institutet. Now in retrospect it sounds like a very long time, but time goes so fast when you are having fun! I would like to take this opportunity to thank some of the wonderful and inspiring people that I have had the great pleasure of meeting and working with during these years:

My supervisor Prof. Elias Arnér, you are an excellent researcher and you have been a terrific supervisor. I am so pleased and grateful for getting the opportunity to study for my PhD within your lab. Your interest, passion for science and support during these years have made my time as a graduate student fun and rewarding.

Prof. Arne Holmgren, for invaluable discussions during my Wednesday seminars and otherwise. Your genuine commitment to research is a source of inspiration and it is always entertaining to listen to you telling stories about the old days.

Lena Ringdén for the enormous amount of administrative help and for always being so cheerful and willing to help.

Thanks to my fellow group members (past and present)
Drs. Qing Cheng and Jianqiang Xu for all your help, warmth and enthusiasm and for the good times in Japan.

Drs. Hanna-Stina Ahlzén, Pascal Dammeyer and Victor Croitoru for great discussions about science and life.

Dr. Katarina Johansson for being so joyful and energizing. Irina Pader for great support and Schoko-Bons. Dr. Olle Rengby for all the singing and entertainment in the lab and for making a superb fish soup.

My current office buddies for creating a great atmosphere at work. Marcus Cebula for always being so patient and willing to have discussions with me. Eldsjälén William Stafford, the king of ice-cream making, and Xiaoxiao Peng (alias Alex the great) for a lot of fun and good teamwork.

Drs. Stefanie Prast-Nielsen, Karin Anestål, Thomas Nordman and Linda Johansson for introducing me to the lab. Karin Anestål for being my supervisor during my *master's* thesis. Stefanie Prast-Nielsen for all the nice discussions and good work together.

Thanks to present and past members of the Arne Holmgren group:
Lars Bräutigam for being a great friend! For sharing your oranges with me, buying me Schoko-Bons and for always being so willing to help both within and outside the lab.

Also many thanks to Tomas Gustafsson, Sergio Montano, Zhang Xu, Jacek Andrzejewski, Monica Riveros and Drs. Jun Lu, Johanna Ungerstedt, Rajib Sengupta, Yatao Du, Hui-Hui Zhang.

And past members:

Drs. Maria Lönn, Christoph Hudemann, Eva-Maria Hanschmann, Malin Fladvad, Carsten Berndt, Alexios Vlamis-Gardikas, Eng-Hui Chew, Farnaz Zahedi Avval, Isaac Hashemy, Christopher Horst Lilling and Cristina Carvalho, Rolf Eliasson and my external mentor Dr. Aristi Fernandes.

Thank you all for creating the open and friendly atmosphere we have at Biochemistry and for the good company during coffee breaks, lunches and more.

Many thanks to all my brilliant co-authors and collaborators

Paper I

Emilie Flaberg, Laszlo Szekely.

Paper II

Karolina Wallenborg, Ola Hermansson, Pinelopi Vlachos and Bertrand Joseph,

Paper III

Elisabeth Hedström, Joanna Zawacka-Pankau and Galina Selivanova.

Paper IV

Victoria Hellberg, Inger Wallin, Emma Hernlund, Elin Jerremalm, Maria Berndtsson, Staffan Ekborg, Maria Shoshan, Hans Ehrsson and Göran Laurell.

Paper V and VI

Edward Schmidt, Sonya Iverson, Justin Prigge, Emily Talago and Jean Kundert, Mario Capecchi, Tesia Meade.

Thank you Ed, Sonya, Emily, Justin and Jean for welcoming and introducing me to life in Bozeman. I had a great time in Montana!

Wig-1 project

Dr. Anna Vilborg, Cinzia Bersani and Prof. Klas Wiman.

People who I have met and gotten to know through MF and the GSA, Emma, Anestis, Mélanie, Adina, Samuel, Melissa, Ulf and many more...

And outside KI...

My dear friends

Lina, Hanna, Nicklas, Sara, Mickan, Susanne, Åsa, Catharina, Charlotte, Jessica, Kåringön girl crew and TUT05.

My family

Jonas, my mother Sonja, Isabella, Olle, Gunnar, Martin, Micke, meine Oma und Opa, Tina, Ulf and Jesper.

REFERENCES

1. Cancerfonden (2010) Cancerfondsrapporten 2010.
2. Hanahan D, Weinberg RA (2000) The hallmarks of cancer. *Cell* 100: 57-70.
3. Hanahan D, Weinberg RA (2011) Hallmarks of cancer: the next generation. *Cell* 144: 646-674.
4. Gogvadze V, Zhivotovsky B, Orrenius S (2010) The Warburg effect and mitochondrial stability in cancer cells. *Mol Aspects Med* 31: 60-74.
5. Winterbourn CC, Hampton MB (2008) Thiol chemistry and specificity in redox signaling. *Free Radic Biol Med* 45: 549-561.
6. Nordberg J, Arnér ESJ (2001) Reactive oxygen species, antioxidants, and the mammalian thioredoxin system. *Free Radic Biol Med* 31: 1287-1312.
7. Finkel T (2003) Oxidant signals and oxidative stress. *Curr Opin Cell Biol* 15: 247-254.
8. Finkel T (2011) Signal transduction by reactive oxygen species. *J Cell Biol* 194: 7-15.
9. Liou GY, Storz P (2010) Reactive oxygen species in cancer. *Free Radic Res* 44: 479-496.
10. Castro L, Freeman BA (2001) Reactive oxygen species in human health and disease. *Nutrition* 17: 161, 163-165.
11. Barbazette J (2008) *Redox Biochemistry*. ; Ruma Banerjee DFB, Martin B. Dickman, Vadim N. Gladyshev, Stephen W. Ragsdale, editor. Hoboken, New Jersey: John Wiley & Sons, Inc. .
12. Hamanaka RB, Chandel NS (2010) Mitochondrial reactive oxygen species regulate cellular signaling and dictate biological outcomes. *Trends Biochem Sci* 35: 505-513.
13. Schreck R, Albermann K, Baeuerle PA (1992) Nuclear factor kappa B: an oxidative stress-responsive transcription factor of eukaryotic cells (a review). *Free Radic Res Commun* 17: 221-237.
14. Nishiyama A, Masutani H, Nakamura H, Nishinaka Y, Yodoi J (2001) Redox regulation by thioredoxin and thioredoxin-binding proteins. *IUBMB Life* 52: 29-33.
15. Brigelius-Flohe R, Flohe L (2011) Basic principles and emerging concepts in the redox control of transcription factors. *Antioxid Redox Signal* 15: 2335-2381.
16. Mahadev K, Wu X, Zilbering A, Zhu L, Lawrence JT, et al. (2001) Hydrogen peroxide generated during cellular insulin stimulation is integral to activation of the distal insulin signaling cascade in 3T3-L1 adipocytes. *J Biol Chem* 276: 48662-48669.
17. Lee SR, Kwon KS, Kim SR, Rhee SG (1998) Reversible inactivation of protein-tyrosine phosphatase 1B in A431 cells stimulated with epidermal growth factor. *J Biol Chem* 273: 15366-15372.
18. Finkel T, Holbrook NJ (2000) Oxidants, oxidative stress and the biology of ageing. *Nature* 408: 239-247.
19. Chen K, Craige SE, Keaney JF, Jr. (2009) Downstream targets and intracellular compartmentalization in Nox signaling. *Antioxid Redox Signal* 11: 2467-2480.
20. Ushio-Fukai M (2009) Compartmentalization of redox signaling through NADPH oxidase-derived ROS. *Antioxid Redox Signal* 11: 1289-1299.
21. Gueraud F, Atalay M, Bresgen N, Cipak A, Eckl PM, et al. (2010) Chemistry and biochemistry of lipid peroxidation products. *Free Radic Res* 44: 1098-1124.

22. Baker PR, Schopfer FJ, O'Donnell VB, Freeman BA (2009) Convergence of nitric oxide and lipid signaling: anti-inflammatory nitro-fatty acids. *Free Radic Biol Med* 46: 989-1003.
23. Groeger G, Quiney C, Cotter TG (2009) Hydrogen peroxide as a cell-survival signaling molecule. *Antioxid Redox Signal* 11: 2655-2671.
24. Hampton MB, Fadeel B, Orrenius S (1998) Redox regulation of the caspases during apoptosis. *Ann N Y Acad Sci* 854: 328-335.
25. Toyokuni S (2008) Molecular mechanisms of oxidative stress-induced carcinogenesis: from epidemiology to oxygenomics. *IUBMB Life* 60: 441-447.
26. Burdon RH (1995) Superoxide and hydrogen peroxide in relation to mammalian cell proliferation. *Free Radic Biol Med* 18: 775-794.
27. Felty Q, Roy D (2005) Mitochondrial signals to nucleus regulate estrogen-induced cell growth. *Med Hypotheses* 64: 133-141.
28. Nishikawa M (2008) Reactive oxygen species in tumor metastasis. *Cancer Lett* 266: 53-59.
29. Lee SR, Yang KS, Kwon J, Lee C, Jeong W, et al. (2002) Reversible inactivation of the tumor suppressor PTEN by H₂O₂. *J Biol Chem* 277: 20336-20342.
30. Szatrowski TP, Nathan CF (1991) Production of large amounts of hydrogen peroxide by human tumor cells. *Cancer Res* 51: 794-798.
31. Kensler TW, Wakabayashi N, Biswal S (2007) Cell survival responses to environmental stresses via the Keap1-Nrf2-ARE pathway. *Annu Rev Pharmacol Toxicol* 47: 89-116.
32. Lau A, Villeneuve NF, Sun Z, Wong PK, Zhang DD (2008) Dual roles of Nrf2 in cancer. *Pharmacol Res* 58: 262-270.
33. Ramos-Gomez M, Kwak MK, Dolan PM, Itoh K, Yamamoto M, et al. (2001) Sensitivity to carcinogenesis is increased and chemoprotective efficacy of enzyme inducers is lost in nrf2 transcription factor-deficient mice. *Proc Natl Acad Sci U S A* 98: 3410-3415.
34. Singh A, Bodas M, Wakabayashi N, Bunz F, Biswal S (2010) Gain of Nrf2 function in non-small-cell lung cancer cells confers radioresistance. *Antioxid Redox Signal* 13: 1627-1637.
35. Singh A, Misra V, Thimmulappa RK, Lee H, Ames S, et al. (2006) Dysfunctional KEAP1-NRF2 interaction in non-small-cell lung cancer. *PLoS Med* 3: e420.
36. Mandal PK, Seiler A, Perisic T, Kolle P, Banjac Canak A, et al. (2010) System x(c)- and thioredoxin reductase 1 cooperatively rescue glutathione deficiency. *J Biol Chem* 285: 22244-22253.
37. Sakurai A, Nishimoto M, Himeno S, Imura N, Tsujimoto M, et al. (2005) Transcriptional regulation of thioredoxin reductase 1 expression by cadmium in vascular endothelial cells: role of NF-E2-related factor-2. *J Cell Physiol* 203: 529-537.
38. Taniguchi Y, Taniguchi-Ueda Y, Mori K, Yodoi J (1996) A novel promoter sequence is involved in the oxidative stress-induced expression of the adult T-cell leukemia-derived factor (ADF)/human thioredoxin (Trx) gene. *Nucleic Acids Res* 24: 2746-2752.
39. Zhang H, Liu H, Dickinson DA, Liu RM, Postlethwait EM, et al. (2006) gamma-Glutamyl transpeptidase is induced by 4-hydroxynonenal via EpRE/Nrf2 signaling in rat epithelial type II cells. *Free Radic Biol Med* 40: 1281-1292.
40. Harvey CJ, Thimmulappa RK, Singh A, Blake DJ, Ling G, et al. (2009) Nrf2-regulated glutathione recycling independent of biosynthesis is critical for cell survival during oxidative stress. *Free Radic Biol Med* 46: 443-453.
41. Wu KC, Cui JY, Klaassen CD (2011) Beneficial role of nrf2 in regulating NADPH generation and consumption. *Toxicol Sci* 123: 590-600.

42. Schwarz K (1965) Role of vitamin E, selenium, and related factors in experimental nutritional liver disease *Fed Proc* 24: 58-67.
43. Flohe L (2009) The labour pains of biochemical selenology: the history of selenoprotein biosynthesis. *Biochim Biophys Acta* 1790: 1389-1403.
44. Arner ES (2010) Selenoproteins-What unique properties can arise with selenocysteine in place of cysteine? *Exp Cell Res* 316: 1296-1303.
45. Lobanov AV, Hatfield DL, Gladyshev VN (2009) Eukaryotic selenoproteins and selenoproteomes. *Biochim Biophys Acta* 1790: 1424-1428.
46. Kryukov GV, Castellano S, Novoselov SV, Lobanov AV, Zehtab O, et al. (2003) Characterization of mammalian selenoproteomes. *Science* 300: 1439-1443.
47. Burk RF, Hill KE (2009) Selenoprotein P-expression, functions, and roles in mammals. *Biochim Biophys Acta* 1790: 1441-1447.
48. Xu XM, Carlson BA, Zhang Y, Mix H, Kryukov GV, et al. (2007) New developments in selenium biochemistry: selenocysteine biosynthesis in eukaryotes and archaea. *Biol Trace Elem Res* 119: 234-241.
49. Allmang C, Wurth L, Krol A (2009) The selenium to selenoprotein pathway in eukaryotes: more molecular partners than anticipated. *Biochim Biophys Acta* 1790: 1415-1423.
50. Berry MJ, Banu L, Harney JW, Larsen PR (1993) Functional characterization of the eukaryotic SECIS elements which direct selenocysteine insertion at UGA codons. *EMBO J* 12: 3315-3322.
51. Turanov AA, Lobanov AV, Fomenko DE, Morrison HG, Sogin ML, et al. (2009) Genetic code supports targeted insertion of two amino acids by one codon. *Science* 323: 259-261.
52. Lu J, Zhong L, Lonn ME, Burk RF, Hill KE, et al. (2009) Penultimate selenocysteine residue replaced by cysteine in thioredoxin reductase from selenium-deficient rat liver. *FASEB J* 23: 2394-2402.
53. Xu XM, Turanov AA, Carlson BA, Yoo MH, Everley RA, et al. (2010) Targeted insertion of cysteine by decoding UGA codons with mammalian selenocysteine machinery. *Proc Natl Acad Sci U S A* 107: 21430-21434.
54. Papp LV, Lu J, Striebel F, Kennedy D, Holmgren A, et al. (2006) The redox state of SECIS binding protein 2 controls its localization and selenocysteine incorporation function. *Mol Cell Biol* 26: 4895-4910.
55. Lu J, Holmgren A (2009) Selenoproteins. *J Biol Chem* 284: 723-727.
56. Gromer S, Gross JH (2002) Methylseleninate is a substrate rather than an inhibitor of mammalian thioredoxin reductase. Implications for the antitumor effects of selenium. *J Biol Chem* 277: 9701-9706.
57. (TOXNET®) NLoMsTDN (2011-10-11) Hazardous Substances Data Bank (HSDB®) <http://toxnet.nlm.nih.gov/cgi-bin/sis/search/f?./temp/~EjV9IG:1>.
58. Papp LV, Holmgren A, Khanna KK (2009) Selenium and selenoproteins in health and disease. *Antioxid Redox Signal* 12: 793-795.
59. Ganther HE (1999) Selenium metabolism, selenoproteins and mechanisms of cancer prevention: complexities with thioredoxin reductase. *Carcinogenesis* 20: 1657-1666.
60. Clark LC, Combs GF, Jr., Turnbull BW, Slate EH, Chalker DK, et al. (1996) Effects of selenium supplementation for cancer prevention in patients with carcinoma of the skin. A randomized controlled trial. Nutritional Prevention of Cancer Study Group. *Jama* 276: 1957-1963.
61. Clark LC, Dalkin B, Krongrad A, Combs GF, Jr., Turnbull BW, et al. (1998) Decreased incidence of prostate cancer with selenium supplementation: results of a double-blind cancer prevention trial. *Br J Urol* 81: 730-734.

62. Irons R, Carlson BA, Hatfield DL, Davis CD (2006) Both selenoproteins and low molecular weight selenocompounds reduce colon cancer risk in mice with genetically impaired selenoprotein expression. *J Nutr* 136: 1311-1317.
63. Rayman MP (2009) Selenoproteins and human health: insights from epidemiological data. *Biochim Biophys Acta* 1790: 1533-1540.
64. Duffield-Lillico AJ, Reid ME, Turnbull BW, Combs GF, Jr., Slate EH, et al. (2002) Baseline characteristics and the effect of selenium supplementation on cancer incidence in a randomized clinical trial: a summary report of the Nutritional Prevention of Cancer Trial. *Cancer Epidemiol Biomarkers Prev* 11: 630-639.
65. Navarro-Alarcon M, Cabrera-Vique C (2008) Selenium in food and the human body: a review. *Sci Total Environ* 400: 115-141.
66. Galati G, O'Brien PJ (2004) Potential toxicity of flavonoids and other dietary phenolics: significance for their chemopreventive and anticancer properties. *Free Radic Biol Med* 37: 287-303.
67. Halliwell B (2008) Are polyphenols antioxidants or pro-oxidants? What do we learn from cell culture and in vivo studies? *Arch Biochem Biophys* 476: 107-112.
68. Kraft TE, Parisotto D, Schempp C, Efferth T (2009) Fighting cancer with red wine? Molecular mechanisms of resveratrol. *Crit Rev Food Sci Nutr* 49: 782-799.
69. Forester SC, Lambert JD The role of antioxidant versus pro-oxidant effects of green tea polyphenols in cancer prevention. *Mol Nutr Food Res* 55: 844-854.
70. D'Alessandro A, Zolla L (2011) The SODyssey: superoxide dismutases from biochemistry, through proteomics, to oxidative stress, aging and nutraceuticals. *Expert Rev Proteomics* 8: 405-421.
71. Rhee SG, Kang SW, Chang TS, Jeong W, Kim K (2001) Peroxiredoxin, a novel family of peroxidases. *IUBMB Life* 52: 35-41.
72. Thelander L, Reichard P (1979) Reduction of ribonucleotides. *Annu Rev Biochem* 48: 133-158.
73. Nordlund P, Reichard P (2006) Ribonucleotide reductases. *Annu Rev Biochem* 75: 681-706.
74. Laurent TC, Moore EC, Reichard P (1964) Enzymatic Synthesis of Deoxyribonucleotides. Iv. Isolation and Characterization of Thioredoxin, the Hydrogen Donor from *Escherichia Coli* B. *J Biol Chem* 239: 3436-3444.
75. Zahedi Avval F, Holmgren A (2009) Molecular mechanisms of thioredoxin and glutaredoxin as hydrogen donors for Mammalian s phase ribonucleotide reductase. *J Biol Chem* 284: 8233-8240.
76. Holmgren A (1976) Hydrogen donor system for *Escherichia coli* ribonucleoside-diphosphate reductase dependent upon glutathione. *Proc Natl Acad Sci U S A* 73: 2275-2279.
77. Pompella A, Visvikis A, Paolicchi A, De Tata V, Casini AF (2003) The changing faces of glutathione, a cellular protagonist. *Biochem Pharmacol* 66: 1499-1503.
78. Thieme R, Pai EF, Schirmer RH, Schulz GE (1981) Three-dimensional structure of glutathione reductase at 2 Å resolution. *J Mol Biol* 152: 763-782.
79. Cappellini MD, Fiorelli G (2008) Glucose-6-phosphate dehydrogenase deficiency. *Lancet* 371: 64-74.
80. Brigelius-Flohe R, Kipp A (2009) Glutathione peroxidases in different stages of carcinogenesis. *Biochim Biophys Acta* 1790: 1555-1568.
81. Lillig CH, Berndt C, Holmgren A (2008) Glutaredoxin systems. *Biochim Biophys Acta* 1780: 1304-1317.
82. Berndt C, Lillig CH, Holmgren A (2006) Thiol-based mechanisms of the thioredoxin and glutaredoxin systems: implications for diseases in the cardiovascular system. *Am J Physiol Heart Circ Physiol*.

83. Hirota K, Matsui M, Murata M, Takashima Y, Cheng FS, et al. (2000) Nucleoredoxin, glutaredoxin, and thioredoxin differentially regulate NF-kappaB, AP-1, and CREB activation in HEK293 cells. *Biochem Biophys Res Commun* 274: 177-182.
84. Johansson C, Lillig CH, Holmgren A (2004) Human mitochondrial glutaredoxin reduces S-glutathionylated proteins with high affinity accepting electrons from either glutathione or thioredoxin reductase. *J Biol Chem* 279: 7537-7543.
85. Townsend DM, Tew KD (2003) The role of glutathione-S-transferase in anti-cancer drug resistance. *Oncogene* 22: 7369-7375.
86. Hayes JD, Flanagan JU, Jowsey IR (2005) Glutathione transferases. *Annu Rev Pharmacol Toxicol* 45: 51-88.
87. Dekant W (2003) Biosynthesis of toxic glutathione conjugates from halogenated alkenes. *Toxicol Lett* 144: 49-54.
88. Hanigan MH, Townsend DM, Cooper AJ (2009) Metabolism of cisplatin to a nephrotoxin. *Toxicology* 257: 174-175; author reply 176-177.
89. Luthman M, Holmgren A (1982) Rat liver thioredoxin and thioredoxin reductase: purification and characterization. *Biochemistry* 21: 6628-6633.
90. Arner ES, Holmgren A (2000) Physiological functions of thioredoxin and thioredoxin reductase. *Eur J Biochem* 267: 6102-6109.
91. Pekkari K, Holmgren A (2004) Truncated thioredoxin: physiological functions and mechanism. *Antioxid Redox Signal* 6: 53-61.
92. Matsui M, Oshima M, Oshima H, Takaku K, Maruyama T, et al. (1996) Early embryonic lethality caused by targeted disruption of the mouse thioredoxin gene. *Dev Biol* 178: 179-185.
93. Nonn L, Williams RR, Erickson RP, Powis G (2003) The absence of mitochondrial thioredoxin 2 causes massive apoptosis, exencephaly, and early embryonic lethality in homozygous mice. *Mol Cell Biol* 23: 916-922.
94. Mitsui A, Hamuro J, Nakamura H, Kondo N, Hirabayashi Y, et al. (2002) Overexpression of human thioredoxin in transgenic mice controls oxidative stress and life span. *Antioxid Redox Signal* 4: 693-696.
95. Rigobello MP, Callegaro MT, Barzon E, Benetti M, Bindoli A (1998) Purification of mitochondrial thioredoxin reductase and its involvement in the redox regulation of membrane permeability. *Free Radic Biol Med* 24: 370-376.
96. Sun QA, Su D, Novoselov SV, Carlson BA, Hatfield DL, et al. (2005) Reaction mechanism and regulation of mammalian thioredoxin/glutathione reductase. *Biochemistry* 44: 14528-14537.
97. Conrad M, Jakupoglu C, Moreno SG, Lippl S, Banjac A, et al. (2004) Essential role for mitochondrial thioredoxin reductase in hematopoiesis, heart development, and heart function. *Mol Cell Biol* 24: 9414-9423.
98. Jakupoglu C, Przemeczek GK, Schneider M, Moreno SG, Mayr N, et al. (2005) Cytoplasmic thioredoxin reductase is essential for embryogenesis but dispensable for cardiac development. *Mol Cell Biol* 25: 1980-1988.
99. Bondareva AA, Capecchi MR, Iverson SV, Li Y, Lopez NI, et al. (2007) Effects of thioredoxin reductase-1 deletion on embryogenesis and transcriptome. *Free Radic Biol Med* 43: 911-923.
100. Conrad M (2009) Transgenic mouse models for the vital selenoenzymes cytosolic thioredoxin reductase, mitochondrial thioredoxin reductase and glutathione peroxidase 4. *Biochim Biophys Acta* 1790: 1575-1585.
101. Soerensen J, Jakupoglu C, Beck H, Forster H, Schmidt J, et al. (2008) The role of thioredoxin reductases in brain development. *PLoS One* 3: e1813.

102. Suvorova ES, Lucas O, Weisend CM, Rollins MF, Merrill GF, et al. (2009) Cytoprotective Nrf2 pathway is induced in chronically txnrd 1-deficient hepatocytes. *PLoS One* 4: e6158.
103. Rollins MF, van der Heide DM, Weisend CM, Kundert JA, Comstock KM, et al. (2010) Hepatocytes lacking thioredoxin reductase 1 have normal replicative potential during development and regeneration. *J Cell Sci* 123: 2402-2412.
104. Berggren M, Gallegos A, Gasdaska JR, Gasdaska PY, Warneke J, et al. (1996) Thioredoxin and thioredoxin reductase gene expression in human tumors and cell lines, and the effects of serum stimulation and hypoxia. *Anticancer Res* 16: 3459-3466.
105. Peters U, Chatterjee N, Hayes RB, Schoen RE, Wang Y, et al. (2008) Variation in the selenoenzyme genes and risk of advanced distal colorectal adenoma. *Cancer Epidemiol Biomarkers Prev* 17: 1144-1154.
106. Raffel J, Bhattacharyya AK, Gallegos A, Cui H, Einspahr JG, et al. (2003) Increased expression of thioredoxin-1 in human colorectal cancer is associated with decreased patient survival. *J Lab Clin Med* 142: 46-51.
107. Urig S, Becker K (2006) On the potential of thioredoxin reductase inhibitors for cancer therapy. *Semin Cancer Biol* 16: 452-465.
108. Arner ES, Holmgren A (2006) The thioredoxin system in cancer. *Semin Cancer Biol* 16: 420-426.
109. Yoo MH, Xu XM, Carlson BA, Gladyshev VN, Hatfield DL (2006) Thioredoxin reductase 1 deficiency reverses tumor phenotype and tumorigenicity of lung carcinoma cells. *J Biol Chem* 281: 13005-13008.
110. Mandal PK, Schneider M, Kolle P, Kuhlencordt P, Forster H, et al. (2010) Loss of thioredoxin reductase 1 renders tumors highly susceptible to pharmacologic glutathione deprivation. *Cancer Res* 70: 9505-9514.
111. Eklund H, Gleason FK, Holmgren A (1991) Structural and functional relations among thioredoxins of different species. *Proteins* 11: 13-28.
112. Lee BC, Dikiy A, Kim HY, Gladyshev VN (2009) Functions and evolution of selenoprotein methionine sulfoxide reductases. *Biochim Biophys Acta* 1790: 1471-1477.
113. Hirota K, Murata M, Sachi Y, Nakamura H, Takeuchi J, et al. (1999) Distinct roles of thioredoxin in the cytoplasm and in the nucleus. A two-step mechanism of redox regulation of transcription factor NF-kappaB. *J Biol Chem* 274: 27891-27897.
114. Matthews JR, Wakasugi N, Virelizier JL, Yodoi J, Hay RT (1992) Thioredoxin regulates the DNA binding activity of NF-kappa B by reduction of a disulphide bond involving cysteine 62. *Nucleic Acids Res* 20: 3821-3830.
115. Freemerman AJ, Gallegos A, Powis G (1999) Nuclear factor kappaB transactivation is increased but is not involved in the proliferative effects of thioredoxin overexpression in MCF-7 breast cancer cells. *Cancer Res* 59: 4090-4094.
116. Hirota K, Matsui M, Iwata S, Nishiyama A, Mori K, et al. (1997) AP-1 transcriptional activity is regulated by a direct association between thioredoxin and Ref-1. *Proc Natl Acad Sci U S A* 94: 3633-3638.
117. Hirota K, Nishiyama A, Yodoi J (1999) Reactive oxygen intermediates, thioredoxin, and Ref-1 as effector molecules in cellular signal transduction. *Tanpakushitsu Kakusan Koso* 44: 2414-2419.
118. Kim WJ, Cho H, Lee SW, Kim YJ, Kim KW (2005) Antisense-thioredoxin inhibits angiogenesis via pVHL-mediated hypoxia-inducible factor-1alpha degradation. *Int J Oncol* 26: 1049-1052.

119. Holmgren A (1977) Bovine thioredoxin system. Purification of thioredoxin reductase from calf liver and thymus and studies of its function in disulfide reduction. *J Biol Chem* 252: 4600-4606.
120. Holmgren A (1985) Thioredoxin. *Annu Rev Biochem* 54: 237-271.
121. Kanzok SM, Fechner A, Bauer H, Ulschmid JK, Muller HM, et al. (2001) Substitution of the thioredoxin system for glutathione reductase in *Drosophila melanogaster*. *Science* 291: 643-646.
122. Saitoh M, Nishitoh H, Fujii M, Takeda K, Tobiume K, et al. (1998) Mammalian thioredoxin is a direct inhibitor of apoptosis signal-regulating kinase (ASK) 1. *Embo J* 17: 2596-2606.
123. Meuillet EJ, Mahadevan D, Berggren M, Coon A, Powis G (2004) Thioredoxin-1 binds to the C2 domain of PTEN inhibiting PTEN's lipid phosphatase activity and membrane binding: a mechanism for the functional loss of PTEN's tumor suppressor activity. *Arch Biochem Biophys* 429: 123-133.
124. Chen Z, Lopez-Ramos DA, Yoshihara E, Maeda Y, Masutani H, et al. Thioredoxin-binding protein-2 (TBP-2/VDUP1/TXNIP) regulates T-cell sensitivity to glucocorticoid during HTLV-I-induced transformation. *Leukemia* 25: 440-448.
125. Vogelstein B, Lane D, Levine AJ (2000) Surfing the p53 network. *Nature* 408: 307-310.
126. Pearson GD, Merrill GF (1998) Deletion of the *Saccharomyces cerevisiae* TRR1 gene encoding thioredoxin reductase inhibits p53-dependent reporter gene expression. *J Biol Chem* 273: 5431-5434.
127. Moos PJ, Edes K, Cassidy P, Massuda E, Fitzpatrick FA (2003) Electrophilic prostaglandins and lipid aldehydes repress redox-sensitive transcription factors p53 and hypoxia-inducible factor by impairing the selenoprotein thioredoxin reductase. *J Biol Chem* 278: 745-750.
128. Cassidy PB, Edes K, Nelson CC, Parsawar K, Fitzpatrick FA, et al. (2006) Thioredoxin reductase is required for the inactivation of tumor suppressor p53 and for apoptosis induced by endogenous electrophiles. *Carcinogenesis* 27: 2538-2549.
129. Ueno M, Masutani H, Arai RJ, Yamauchi A, Hirota K, et al. (1999) Thioredoxin-dependent redox regulation of p53-mediated p21 activation. *J Biol Chem* 274: 35809-35815.
130. Sandalova T, Zhong L, Lindqvist Y, Holmgren A, Schneider G (2001) Three-dimensional structure of a mammalian thioredoxin reductase: implications for mechanism and evolution of a selenocysteine-dependent enzyme. *Proc Natl Acad Sci U S A* 98: 9533-9538.
131. Arner ES (2009) Focus on mammalian thioredoxin reductases--important selenoproteins with versatile functions. *Biochim Biophys Acta* 1790: 495-526.
132. Tamura T, Gladyshev V, Liu SY, Stadtman TC (1995) The mutual sparing effects of selenium and vitamin E in animal nutrition may be further explained by the discovery that mammalian thioredoxin reductase is a selenoenzyme. *Biofactors* 5: 99-102.
133. Tamura T, Stadtman TC (1996) A new selenoprotein from human lung adenocarcinoma cells: purification, properties, and thioredoxin reductase activity. *Proc Natl Acad Sci U S A* 93: 1006-1011.
134. Gladyshev VN, Jeang KT, Stadtman TC (1996) Selenocysteine, identified as the penultimate C-terminal residue in human T-cell thioredoxin reductase, corresponds to TGA in the human placental gene. *Proc Natl Acad Sci U S A* 93: 6146-6151.

135. Osborne SA, Tonissen KF (2001) Genomic organisation and alternative splicing of mouse and human thioredoxin reductase 1 genes. *BMC Genomics* 2: 10.
136. Williams CH, Jr. (1995) Mechanism and structure of thioredoxin reductase from *Escherichia coli*. *FASEB J* 9: 1267-1276.
137. Dammeyer P, Dandimopoulos AE, Nordman T, Jimenez A, Miranda-Vizuete A, et al. (2008) Induction of cell membrane protrusions by the N-terminal glutaredoxin domain of a rare splice variant of human thioredoxin reductase 1. *Journal of Biological Chemistry* 283: 2814-2821.
138. Rundlof AK, Janard M, Miranda-Vizuete A, Arner ES (2004) Evidence for intriguingly complex transcription of human thioredoxin reductase 1. *Free Radic Biol Med* 36: 641-656.
139. Gasdaska JR, Harney JW, Gasdaska PY, Powis G, Berry MJ (1999) Regulation of human thioredoxin reductase expression and activity by 3'-untranslated region selenocysteine insertion sequence and mRNA instability elements. *J Biol Chem* 274: 25379-25385.
140. Mukherjee N, Lager PJ, Friedersdorf MB, Thompson MA, Keene JD (2009) Coordinated posttranscriptional mRNA population dynamics during T-cell activation. *Mol Syst Biol* 5: 288.
141. Emmons J, Townley-Tilson WH, Deleault KM, Skinner SJ, Gross RH, et al. (2008) Identification of TTP mRNA targets in human dendritic cells reveals TTP as a critical regulator of dendritic cell maturation. *RNA* 14: 888-902.
142. Zhong L, Holmgren A (2000) Essential role of selenium in the catalytic activities of mammalian thioredoxin reductase revealed by characterization of recombinant enzymes with selenocysteine mutations. *J Biol Chem* 275: 18121-18128.
143. Cheng Q, Sandalova T, Lindqvist Y, Arner ES (2009) Crystal structure and catalysis of the selenoprotein thioredoxin reductase 1. *J Biol Chem* 284: 3998-4008.
144. Zhong L, Persson K, Sandalova T, Schneider G, Holmgren A (2000) Purification, crystallization and preliminary crystallographic data for rat cytosolic selenocysteine 498 to cysteine mutant thioredoxin reductase. *Acta Crystallogr D Biol Crystallogr* 56 (Pt 9): 1191-1193.
145. Cheng Q, Antholine WE, Myers JM, Kalyanaraman B, Arner ES, et al. (2010) The selenium-independent inherent pro-oxidant NADPH oxidase activity of mammalian thioredoxin reductase and its selenium-dependent direct peroxidase activities. *J Biol Chem* 285: 21708-21723.
146. Kumar S, Björnstedt M, Holmgren A (1992) Selenite is a substrate for calf thymus thioredoxin reductase and thioredoxin and elicits a large non-stoichiometric oxidation of NADPH in the presence of oxygen. *Eur J Biochem* 207: 435-439.
147. Arnér ESJ, Zhong L, Holmgren A (1999) Preparation and assay of mammalian thioredoxin and thioredoxin reductase. *Methods Enzymol* 300: 226-239.
148. Björnstedt M, Hamberg M, Kumar S, Xue J, Holmgren A (1995) Human thioredoxin reductase directly reduces lipid hydroperoxides by NADPH and selenocystine strongly stimulates the reaction via catalytically generated selenols. *J Biol Chem* 270: 11761-11764.
149. Arnér ESJ, Nordberg J, Holmgren A (1996) Efficient reduction of lipoamide and lipoic acid by mammalian thioredoxin reductase. *Biochem Biophys Res Commun* 225: 268-274.
150. May JM, Mendiratta S, Hill KE, Burk RF (1997) Reduction of dehydroascorbate to ascorbate by the selenoenzyme thioredoxin reductase. *J Biol Chem* 272: 22607-22610.

151. May JM, Cobb CE, Mendiratta S, Hill KE, Burk RF (1998) Reduction of the ascorbyl free radical to ascorbate by thioredoxin reductase. *J Biol Chem* 273: 23039-23045.
152. Jeong W, Yoon HW, Lee SR, Rhee SG (2004) Identification and characterization of TRP14, a thioredoxin-related protein of 14 kDa. New insights into the specificity of thioredoxin function. *J Biol Chem* 279: 3142-3150.
153. Jeong W, Jung Y, Kim H, Park SJ, Rhee SG (2009) Thioredoxin-related protein 14, a new member of the thioredoxin family with disulfide reductase activity: implication in the redox regulation of TNF-alpha signaling. *Free Radic Biol Med* 47: 1294-1303.
154. Becker K, Gromer S, Schirmer RH, Muller S (2000) Thioredoxin reductase as a pathophysiological factor and drug target. *Eur J Biochem* 267: 6118-6125.
155. Gromer S, Arscott LD, Williams CH, Jr., Schirmer RH, Becker K (1998) Human placenta thioredoxin reductase. Isolation of the selenoenzyme, steady state kinetics, and inhibition by therapeutic gold compounds. *J Biol Chem* 273: 20096-20101.
156. Zhang J, Lu H (2007) Ifosfamide induces acute renal failure via inhibition of the thioredoxin reductase activity. *Free Radic Biol Med* 43: 1574-1583.
157. Wang X, Zhang J, Xu T (2008) Thioredoxin reductase inactivation as a pivotal mechanism of ifosfamide in cancer therapy. *Eur J Pharmacol* 579: 66-73.
158. Lu J, Chew EH, Holmgren A (2007) Targeting thioredoxin reductase is a basis for cancer therapy by arsenic trioxide. *Proc Natl Acad Sci U S A* 104: 12288-12293.
159. Arnér ESJ, Nakamura H, Sasada T, Yodoi J, Holmgren A, et al. (2001) Analysis of the inhibition of mammalian thioredoxin, thioredoxin reductase, and glutaredoxin by cis-diamminedichloroplatinum (II) and its major metabolite, the glutathione-platinum complex. *Free Radic Biol Med* 31: 1170-1178.
160. Witte AB, Anestal K, Jerremalm E, Ehrsson H, Arner ESJ (2005) Inhibition of thioredoxin reductase but not of glutathione reductase by the major classes of alkylating and platinum-containing anticancer compounds. *Free Radical Biology and Medicine* 39: 696-703.
161. Fang J, Holmgren A (2006) Inhibition of thioredoxin and thioredoxin reductase by 4-hydroxy-2-nonenal in vitro and in vivo. *J Am Chem Soc* 128: 1879-1885.
162. Brown KK, Eriksson SE, Arner ESJ, Hampton MB (2008) Mitochondrial peroxiredoxin 3 is rapidly oxidized in cells treated. *Free Radical Biology and Medicine* 45: 494-502.
163. Arnér ESJ, Bjornstedt M, Holmgren A (1995) 1-Chloro-2,4-dinitrobenzene is an irreversible inhibitor of human thioredoxin reductase. Loss of thioredoxin disulfide reductase activity is accompanied by a large increase in NADPH oxidase activity. *J Biol Chem* 270: 3479-3482.
164. Fang J, Lu J, Holmgren A (2005) Thioredoxin reductase is irreversibly modified by curcumin: a novel molecular mechanism for its anticancer activity. *J Biol Chem* 280: 25284-25290.
165. Cenas N, Prast S, Nivinskas H, Sarlauskas J, Arner ES (2006) Interactions of nitroaromatic compounds with the mammalian selenoprotein thioredoxin reductase and the relation to induction of apoptosis in human cancer cells. *J Biol Chem* 281: 5593-5603.
166. Anestal K, Prast-Nielsen S, Cenas N, Arner ES (2008) Cell death by SecTRAPs: thioredoxin reductase as a prooxidant killer of cells. *PLoS ONE* 3: e1846.
167. Talbot S, Nelson R, Self WT (2008) Arsenic trioxide and auranofin inhibit selenoprotein synthesis: implications for chemotherapy for acute promyelocytic leukaemia. *Br J Pharmacol* 154: 940-948.

168. Rosenberg B, Vancamp L, Krigas T (1965) Inhibition of Cell Division in *Escherichia Coli* by Electrolysis Products from a Platinum Electrode. *Nature* 205: 698-699.
169. Burger H, Loos WJ, Eechoute K, Verweij J, Mathijssen RH, et al. Drug transporters of platinum-based anticancer agents and their clinical significance. *Drug Resist Updat* 14: 22-34.
170. Chirino YI, Pedraza-Chaverri J (2009) Role of oxidative and nitrosative stress in cisplatin-induced nephrotoxicity. *Exp Toxicol Pathol* 61: 223-242.
171. Ronald P. Miller RKT, Ganesan Ramesh and William Brian Reeves (2010) Mechanisms of Cisplatin Nephrotoxicity. *toxins* 2: 2490-2518.
172. Reedijk J, Lohman PH (1985) Cisplatin: synthesis, antitumour activity and mechanism of action. *Pharm Weekbl Sci* 7: 173-180.
173. Poirrier AL, Pincemail J, Van Den Ackerveken P, Lefebvre PP, Malgrange B Oxidative stress in the cochlea: an update. *Curr Med Chem* 17: 3591-3604.
174. Launay-Vacher V, Rey JB, Isnard-Bagnis C, Deray G, Daouphars M (2008) Prevention of cisplatin nephrotoxicity: state of the art and recommendations from the European Society of Clinical Pharmacy Special Interest Group on Cancer Care. *Cancer Chemother Pharmacol* 61: 903-909.
175. Zhang J, Wang X, Lu H (2008) Amifostine increases cure rate of cisplatin on ascites hepatoma 22 via selectively protecting renal thioredoxin reductase. *Cancer Lett* 260: 127-136.
176. Desoize B, Madoulet C (2002) Particular aspects of platinum compounds used at present in cancer treatment. *Crit Rev Oncol Hematol* 42: 317-325.
177. Sasada T, Nakamura H, Ueda S, Sato N, Kitaoka Y, et al. (1999) Possible involvement of thioredoxin reductase as well as thioredoxin in cellular sensitivity to cis-diamminedichloroplatinum (II). *Free Radic Biol Med* 27: 504-514.
178. Yokomizo A, Ono M, Nanri H, Makino Y, Ohga T, et al. (1995) Cellular levels of thioredoxin associated with drug sensitivity to cisplatin, mitomycin C, doxorubicin, and etoposide. *Cancer Res* 55: 4293-4296.
179. Mochizuki M, Kwon YW, Yodoi J, Masutani H (2009) Thioredoxin regulates cell cycle via the ERK1/2-cyclin D1 pathway. *Antioxid Redox Signal* 11: 2957-2971.
180. Cullen BR (2006) Enhancing and confirming the specificity of RNAi experiments. *Nat Methods* 3: 677-681.
181. Wardman P (2007) Fluorescent and luminescent probes for measurement of oxidative and nitrosative species in cells and tissues: progress, pitfalls, and prospects. *Free Radic Biol Med* 43: 995-1022.
182. Mannervik B (1999) Measurement of Glutathione Reductase Activity. *Current protocols in toxicology*.
183. Habig WH, Pabst MJ, Jakoby WB (1974) Glutathione S-transferases. The first enzymatic step in mercapturic acid formation. *J Biol Chem* 249: 7130-7139.
184. Guthenberg C, Jensson H, Nystrom L, Osterlund E, Tahir MK, et al. (1985) Isoenzymes of glutathione transferase in rat kidney cytosol. *Biochem J* 230: 609-615.
185. Vandeputte C, Guizon I, Genestie-Denis I, Vannier B, Lorenzon G (1994) A microtiter plate assay for total glutathione and glutathione disulfide contents in cultured/isolated cells: performance study of a new miniaturized protocol. *Cell Biol Toxicol* 10: 415-421.
186. Poirrier AL, Van den Ackerveken P, Kim TS, Vandenbosch R, Nguyen L, et al. Ototoxic drugs: difference in sensitivity between mice and guinea pigs. *Toxicol Lett* 193: 41-49.

187. Gu H, Zou YR, Rajewsky K (1993) Independent control of immunoglobulin switch recombination at individual switch regions evidenced through Cre-loxP-mediated gene targeting. *Cell* 73: 1155-1164.
188. Muzumdar MD, Tasic B, Miyamichi K, Li L, Luo L (2007) A global double-fluorescent Cre reporter mouse. *Genesis* 45: 593-605.
189. Postic C, Shiota M, Niswender KD, Jetton TL, Chen Y, et al. (1999) Dual roles for glucokinase in glucose homeostasis as determined by liver and pancreatic beta cell-specific gene knock-outs using Cre recombinase. *J Biol Chem* 274: 305-315.
190. Guo C, Yang W, Lobe CG (2002) A Cre recombinase transgene with mosaic, widespread tamoxifen-inducible action. *Genesis* 32: 8-18.
191. Nalvarte I, Damdimopoulos AE, Nystom C, Nordman T, Miranda-Vizuete A, et al. (2004) Overexpression of enzymatically active human cytosolic and mitochondrial thioredoxin reductase in HEK-293 cells - Effect on cell growth and differentiation. *Journal of Biological Chemistry* 279: 54510-54517.
192. Wiman KG Pharmacological reactivation of mutant p53: from protein structure to the cancer patient. *Oncogene* 29: 4245-4252.
193. Brosh R, Rotter V (2009) When mutants gain new powers: news from the mutant p53 field. *Nat Rev Cancer* 9: 701-713.
194. Brown CJ, Lain S, Verma CS, Fersht AR, Lane DP (2009) Awakening guardian angels: drugging the p53 pathway. *Nat Rev Cancer* 9: 862-873.
195. Issaeva N, Bozko P, Enge M, Protopopova M, Verhoef LG, et al. (2004) Small molecule RITA binds to p53, blocks p53-HDM-2 interaction and activates p53 function in tumors. *Nat Med* 10: 1321-1328.
196. Merrill GF, Dowell P, Pearson GD (1999) The human p53 negative regulatory domain mediates inhibition of reporter gene transactivation in yeast lacking thioredoxin reductase. *Cancer Res* 59: 3175-3179.
197. Rivera MI, Stinson SF, Vistica DT, Jordan JL, Kenney S, et al. (1999) Selective toxicity of the tricyclic thiophene NSC 652287 in renal carcinoma cell lines: differential accumulation and metabolism. *Biochem Pharmacol* 57: 1283-1295.
198. Covas MI, Gambert P, Fito M, de la Torre R Wine and oxidative stress: up-to-date evidence of the effects of moderate wine consumption on oxidative damage in humans. *Atherosclerosis* 208: 297-304.
199. Fang Y, Nicholl MB (2011) Sirtuin 1 in malignant transformation: friend or foe? *Cancer Lett* 306: 10-14.
200. Lu J, Papp LV, Fang J, Rodriguez-Nieto S, Zhivotovsky B, et al. (2006) Inhibition of Mammalian thioredoxin reductase by some flavonoids: implications for myricetin and quercetin anticancer activity. *Cancer Res* 66: 4410-4418.
201. Mukherjea D, Rybak LP Pharmacogenomics of cisplatin-induced ototoxicity. *Pharmacogenomics* 12: 1039-1050.
202. Turanov AA, Su D, Gladyshev VN (2006) Characterization of alternative cytosolic forms and cellular targets of mouse mitochondrial thioredoxin reductase. *J Biol Chem* 281: 22953-22963.
203. Liu M, Grigoryev DN, Crow MT, Haas M, Yamamoto M, et al. (2009) Transcription factor Nrf2 is protective during ischemic and nephrotoxic acute kidney injury in mice. *Kidney Int* 76: 277-285.
204. Zhou X, Smith AM, Failla ML, Hill KE, Yu Z (2011) Estrogen status alters tissue distribution and metabolism of selenium in female rats. *J Nutr Biochem*.
205. Townsend DM, Tew KD, He L, King JB, Hanigan MH (2009) Role of glutathione S-transferase Pi in cisplatin-induced nephrotoxicity. *Biomed Pharmacother* 63: 79-85.

206. Hebert JM, McConnell SK (2000) Targeting of cre to the Foxg1 (BF-1) locus mediates loxP recombination in the telencephalon and other developing head structures. *Dev Biol* 222: 296-306.
207. Prast-Nielsen S, Cebula M, Pader I, Arner ES (2010) Noble metal targeting of thioredoxin reductase--covalent complexes with thioredoxin and thioredoxin-related protein of 14 kDa triggered by cisplatin. *Free Radic Biol Med* 49: 1765-1778.
208. Jeong W, Chang TS, Boja ES, Fales HM, Rhee SG (2004) Roles of TRP14, a thioredoxin-related protein in tumor necrosis factor-alpha signaling pathways. *J Biol Chem* 279: 3151-3159.
209. Lu J, Berndt C, Holmgren A (2009) Metabolism of selenium compounds catalyzed by the mammalian selenoprotein thioredoxin reductase. *Biochim Biophys Acta* 1790: 1513-1519.
210. Nieves-Neira W, Rivera MI, Kohlhagen G, Hursey ML, Pourquier P, et al. (1999) DNA protein cross-links produced by NSC 652287, a novel thiophene derivative active against human renal cancer cells. *Mol Pharmacol* 56: 478-484.
211. Ushio-Fukai M (2006) Localizing NADPH oxidase-derived ROS. *Sci STKE* 2006: re8.
212. Lu JM, Nurko J, Weakley SM, Jiang J, Kougiyas P, et al. (2010) Molecular mechanisms and clinical applications of nordihydroguaiaretic acid (NDGA) and its derivatives: an update. *Med Sci Monit* 16: RA93-100.
213. Prast-Nielsen S, Dexheimer TS, Schultz L, Stafford WC, Cheng Q, et al. (2011) Inhibition of thioredoxin reductase 1 by porphyrins and other small molecules identified by a high-throughput screening assay. *Free Radic Biol Med* 50: 1114-1123.
214. Goldstein RS, Mayor GH (1983) Minireview. The nephrotoxicity of cisplatin. *Life Sci* 32: 685-690.
215. Rubera I, Poujeol C, Bertin G, Hasseine L, Counillon L, et al. (2004) Specific Cre/Lox recombination in the mouse proximal tubule. *J Am Soc Nephrol* 15: 2050-2056.
216. Maher JM, Dieter MZ, Aleksunes LM, Slitt AL, Guo G, et al. (2007) Oxidative and electrophilic stress induces multidrug resistance-associated protein transporters via the nuclear factor-E2-related factor-2 transcriptional pathway. *Hepatology* 46: 1597-1610.
217. Goldring CE, Kitteringham NR, Elsby R, Randle LE, Clement YN, et al. (2004) Activation of hepatic Nrf2 in vivo by acetaminophen in CD-1 mice. *Hepatology* 39: 1267-1276.
218. Watson WH, Heilman JM, Hughes LL, Spielberger JC (2008) Thioredoxin reductase-1 knock down does not result in thioredoxin-1 oxidation. *Biochem Biophys Res Commun* 368: 832-836.
219. Kimura T, Takeda S, Sagiya Y, Gotoh M, Nakamura Y, et al. (2003) Impaired function of p53R2 in Rrm2b-null mice causes severe renal failure through attenuation of dNTP pools. *Nat Genet* 34: 440-445.