

Swedish Institute for Communicable Disease Control  
Department of Microbiology, Tumor and Cell Biology  
Karolinska Institutet, Stockholm, Sweden

# Genetic and antigenic diversity in *Pneumocystis jirovecii*

Jessica Beser



**Karolinska  
Institutet**

**Smi**

SMITTSKYDDSinSTITUTET

Stockholm 2011

All previously published papers were reproduced with permission from the publisher.

Published by Karolinska Institutet. Printed by Larserics Digital Print AB

© Jessica Beser, 2011

ISBN 978-91-7457-434-0

To Victor

## ABSTRACT

*Pneumocystis jirovecii* is a human specific, atypical fungus with a worldwide distribution that causes disease in immunocompromised individuals. The fungus proliferates in the lungs where it binds to epithelial alveolar cells, provoking severe pneumonia, denoted pneumocystis pneumonia (PCP). As there is no *in vitro* culture system for the organisms, and no morphological means to differentiate between *P. jirovecii* strains, we have used molecular tools to study the fungus in patient samples. For this purpose we have been targeting different loci in the *P. jirovecii* genome (ITS, DHPS and MSG) to address different aspects of *P. jirovecii* infections.

The nucleotide sequence of the internal transcribed spacers (ITS) in *P. jirovecii* has been useful for isolate genotyping. We investigated the genetic diversity in Sweden by analyzing 408 cloned ITS sequences, from 64 clinical specimens. Several globally common haplotypes (combination of ITS1 and ITS2) and one local ITS2 were found. No correlations between certain haplotypes and patient characteristics or geographical associations were uncovered. In this context, a model describing the genealogic relationships of the strains was presented. During this process, we found that the typing system was generating artifactual sequences. We established a set of criteria to determine “*bona fide*” haplotypes, and optimized the typing method to avoid the generation of artifactual recombinants. These improved tools have enabled a more correct assessment of the overestimated genetic diversity of *P. jirovecii* populations.

Trimethoprim-sulfamethoxazole (TMP-SMX) is the most widely used drug for prevention and treatment of PCP. Non-synonymous substitutions in the dihydropteroate synthase (DHPS) gene of *P. jirovecii* have been found to be associated with sulpha exposure. It has been suggested that this is the result of the fungus developing resistance towards the drug. We conducted a study to investigate the presence of *P. jirovecii* DHPS mutations in the Swedish population and 104 specimens from patients with a suspected PCP were screened. All of the specimens (100%) showed a wild-type DHPS pattern, suggesting that there is no, or a very low prevalence of DHPS mutations in the country.

One surface molecule of *P. jirovecii* with a probable key function in the colonization of the alveoli and in immune evasion is the major surface glycoprotein (MSG). The MSGs are encoded by the *msg*-gene family, and transcription is limited to a single *msg*-gene located in a unique expression site. To investigate the expressed *msg*-genes and the extent of the variability of the MSG antigen, we analyzed *msg*-genes located at the expression site. First, we analyzed a short segment of the 5'-end of the *msg*-genes in 13 patient samples. Second, we extended these studies to two full-length *msg*-sequences from two different patients. We concluded, from these analyses, that there is considerable variation in the potentially expressed MSG-proteins, but that a substantial amount of conservation can be found in the *msg*-gene family, even in samples of unrelated origins.

In conclusion, the complexity of *P. jirovecii* populations has been overestimated but typing fidelity can easily be improved. The numbers of ITS haplotypes in Sweden are restricted, and a model depicting the relationships between strains is proposed. Furthermore, *P. jirovecii* DHPS mutations are very rare or possibly even absent in Sweden. Finally, the expressed *msg*-genes display both a remarkable variation and conservation.

## LIST OF PUBLICATIONS

This thesis is based on the following papers. They will be referred to by their roman numerals in the text.

- I. Beser J, Hagblom P and Fernandez V. Frequent in vitro recombination in internal transcribed spacers 1 and 2 during genotyping of *Pneumocystis jirovecii*. J Clin Microbiol. 2007 Mar;45(3):881-6
- II. Beser J, Botero-Kleiven S, Lebbad M, Hagblom P and Fernandez V. A limited number of ITS haplotypes defines the diversity of *Pneumocystis jirovecii* strains in Sweden. Infect Genet Evol. 2011 Jul;11(5):948-54
- III. Beser J, Dini L, Botero-Kleiven S, Krabbe M, Lindh J and Hagblom P. Absence of dihydropteroate synthase gene mutations in *Pneumocystis jirovecii* isolated from Swedish patients. Med Mycol. 2011 Jul 6. [Epub ahead of print]
- IV. Beser J, Joannin N, Botero-Kleiven S, Lindh J and Hagblom P. Variation of the expressed major surface glycoprotein in *Pneumocystis jirovecii*. In manuscript.

# CONTENTS

<b>1</b>	<b>INTRODUCTION TO THE FIELD</b>	<b>1</b>
1.1	HISTORY OF <i>PNEUMOCYSTIS</i>	1
1.1.1	1909 - 1980	1
1.1.2	1981 - Today	2
1.1.3	<i>Pneumocystis</i> infection in Sweden	2
1.2	<i>PNEUMOCYSTIS</i> PNEUMONIA (PCP)	3
1.3	<i>PNEUMOCYSTIS JIROVECI</i>	4
1.3.1	Fungus versus protozoon	4
1.3.2	Host specificity	5
1.3.3	Challenges	5
1.3.4	Genotypes	5
1.3.5	Life cycle	6
1.4	<i>PNEUMOCYSTIS</i> – HOST INTERACTIONS	8
1.4.1	Interactions with lung cells of the host	8
1.4.2	Immune response by the host	8
1.4.3	Transmission	9
1.4.4	Escape from the human immune response	10
1.5	DRUG RESISTANCE	11
<b>2</b>	<b>SCOPE OF THE THESIS</b>	<b>14</b>
<b>3</b>	<b>EXPERIMENTAL PROCEDURES</b>	<b>15</b>
3.1	ETHICAL APPROVALS	15
3.2	SPECIMENS	15
3.3	MOLECULAR PROCEDURES	15
3.4	ANALYSES	16
<b>4</b>	<b>RESULTS AND DISCUSSIONS</b>	<b>17</b>
4.1	EPIDEMIOLOGY AND GENETIC DIVERSITY OF <i>P. JIROVECI</i>	17
4.1.1	<i>In vitro</i> recombination during ITS genotyping	17
4.1.2	Genetic diversity of <i>P. jirovecii</i> isolates	18
4.1.3	Summary	22
4.2	PREVALENCE OF <i>P. JIROVECI</i> DHPS MUTATIONS IN SWEDEN	23
4.2.1	Summary	24
4.3	THE ANTIGENIC VARIATION OF THE <i>MSG</i> -GENE FAMILY	24
4.3.1	N120 sequences	25
4.3.2	Full length <i>msg</i> sequences	27
4.3.3	Summary	27
<b>5</b>	<b>CONCLUSIONS</b>	<b>29</b>
<b>6</b>	<b>ACKNOWLEDGMENTS</b>	<b>30</b>
<b>7</b>	<b>REFERENCES</b>	<b>32</b>

## LIST OF ABBREVIATIONS

BAL	Bronchoalveolar lavage
CRJE	Conserved recombination junction element
DHPS	Dihydropteroate synthase
HAART	Highly active antiretroviral therapy
IF	Immunofluorescence
ITS	Internal transcribed spacers
MSG	Major surface glycoprotein
mt LSU	Mitochondrial large subunit
pABA	Para-aminobenzoic acid
PCP	<i>Pneumocystis pneumonia</i>
PCR	Polymerase chain reaction
SNP	Single nucleotide polymorphism
UCS	Upstream conserved sequence
TMP-SMX	Trimethoprim-sulfamethoxazole





# 1 INTRODUCTION TO THE FIELD

## 1.1 HISTORY OF *PNEUMOCYSTIS*

### 1.1.1 1909 – 1980

*Pneumocystis* was identified for the first time in 1909 by Carlos Chagas, while he was studying a new disease that affected railroad workers in Brazil. Chagas identified cysts in the lungs of guinea pigs that had been inoculated with *Trypanosoma cruzi* infected blood. Initially, he thought what he saw was a new life form of *Trypanosomes* (36). He also found morphologically similar cyst forms in the lungs of a human case of trypanosomiasis (35). In 1910 Antonio Carini identified the same organisms in the lungs of rats infected with *Trypanosoma lewisi* and supported Chagas' finding that they were a stage in the trypanosome life cycle (28). However, two years later, Marie and Pierre Delanoë at the Pasteur Institute in Paris reviewed the finding of Chagas and Carini and inoculated trypanosome-free rats by these kinds of cysts and could conclude, that they in fact, constituted a new microorganism unrelated to *Trypanosomes* (54). Delanoës named this new microorganism *Pneumocystis carinii* to honor Antonio Carini. Subsequently both Chagas and Carini retracted their first conclusions and provided new data that supported the research by Delanoës (8, 25, 33). In the late 1930s an epidemic form of interstitial plasma cell pneumonia in malnourished children was described in Europe (6, 18) and some years later, an association between *Pneumocystis* cysts and plasma cell pneumonia could be demonstrated, histologically, for the first time by van der Meer and Brug (130). Although the association had been described by van der Meer and Brug, three Czech researchers Vaněk, Jírovec and Lukes are most credited for the first description of *Pneumocystis* as a causal agent of human disease (25). In 1952 they described the association between *Pneumocystis* in the lungs of premature and malnourished children with plasma cell pneumonia in nursing homes in Central and Eastern Europe (210). *Pneumocystis* was thereafter described as an important cause of epidemic pneumonia in malnourished and premature children during and after the Second World War. Until the 1980s, starvation and premature birth were the most important predisposition for *Pneumocystis* pneumonia (PCP) (65, 68, 166). In 1958 Ivady and Paldy discovered that the drug pentamidine, that had previously been used to treat trypanosomiasis and leishmaniasis, was also useful to treat infections with *Pneumocystis* (87). The use of this drug led to decreasing mortality of PCP and the improvement in life quality in Europe after the war, and this treatment, led to the disappearance of epidemic PCP among children. In the late 1960s and early 1970, PCP was a rare disease with fewer than 100 cases per year in the USA. However, sporadic cases of PCP began to be described among immunodeficient children and immunosuppressed adults (84, 98, 207). Since pentamidine treatment is associated with high incidence of severe adverse side-effects, Hughes *et al.* discovered in 1975 the efficacy of the combined treatment of trimethoprim-sulfamethoxazole that then became the basis for today's treatment and prophylaxis of PCP (85).

### 1.1.2 1981 – Today

In 1981 Sandra Ford, a drug technician at the Centers for Disease Control (CDC) in Atlanta, USA, observed an unusual high number of requests for the drug pentamidine, used in the treatment of the rare disease PCP. Clinicians in the country also reported an increase of PCP and Kaposi's sarcoma in previously healthy men (31, 32, 69, 125). This was the first evidence of the onset of the AIDS epidemic. After this point the number of cases exploded as PCP became one of the hallmarks of AIDS, and in addition to this a common complication of cancer chemotherapy and organ transplantations. The incidence peaked in 1990 with ~ 20.000 cases reported to the CDC (11, 98). Following that, due to the widespread use of PCP prophylaxis and the introduction of the highly active antiretroviral therapy (HAART) in 1995 and 1996, the incidence started to decrease. However, PCP is still a common problem among those infected with HIV who either are not receiving or are not responding to HAART treatment, and among those who are unaware of their HIV status (21, 23, 98). In Europe, 2.9% of HIV infected persons have been reported to be infected with *Pneumocystis* (140). In another study, among 924 HIV infected patients who died, 56 were caused by *Pneumocystis* infection (21). In a study of HIV patients in the USA from 1994 – 2005, 17% of hospitalizations were due to opportunistic infections and among these, 36% were *Pneumocystis* (24). In Africa, rates between 10% – 39% of *Pneumocystis* infections have been reported among HIV infected patients with respiratory symptoms (1, 37, 121, 122, 209, 218, 224). *Pneumocystis* has also been reported to be the cause of pneumonia in 10% - 40% of patients without HIV (141, 222). The increasing number of patients in the other risk groups such as transplant recipients, patients receiving more aggressive therapies for cancer and other conditions, or in patients with HIV-unrelated immune deficiencies result in an increasing number of individuals at risk for PCP (29, 164, 166, 222).

### 1.1.3 *Pneumocystis* infection in Sweden

PCP is not a notifiable disease in Sweden; there are therefore no available statistics on its incidence in the whole country. The Swedish Institute for Communicable Disease Control (SMI) in Stockholm is responsible for roughly one third to one half of all laboratory analyses for *Pneumocystis* infection in Sweden. For the last 15 years, approximately 50 to 100 cases have been diagnosed per year at SMI; the incidence peaking in 2004 with 97 cases. In addition to morphologic identification of the organisms in the specimens by immunofluorescence (IF) using a monoclonal antibody, 100 to 300 specimens per year are found to be positive by polymerase chain reaction (PCR) (nested PCR or more recently real-time PCR). The number of PCR positive samples is augmenting, probably reflecting the increasing number of specimens that are analysed each year, rather than an increase in the actual incidence of *Pneumocystis* infection. The higher sensitivity of the PCR method also makes it possible to detect *P. jirovecii* DNA at lower concentrations including cases of subclinical colonization. The largest group of patients suffering from PCP during the year 2010 was patients with haematological malignancies (29%). Other underlying causes included

immunosuppression due to HIV infection (12%), inflammatory diseases (12%) and solid tumors (4%). During the last 15 years, HIV positivity among confirmed *Pneumocystis* infections (IF + PCR positive cases), has decreased from 50% to 6%, reflecting a shift in the principal cause of *P. jirovecii* infection. In a retrospective study that identified 118 episodes of PCP in Gothenburg between 1991 and 2001, the number of PCP cases did not increase during the time period, and in total, 75% of the patients were HIV negative, a number that was 0% the first year, 33% the second year and increased to 83% at the last year of the study (137). In conclusion, we estimate that there are between 100 and 300 confirmed PCP cases per year in Sweden. This incidence has been stable during the last 15 years but the most common cause of underlying disease causing immunosuppression has shifted from HIV to haematological malignancies.

## **1.2 PNEUMOCYSTIS PNEUMONIA (PCP)**

*Pneumocystis* causes a severe infection in the lungs of immunocompromised persons, which is characterized as an alveolar interstitial pneumonia. During infection, the alveolar membrane is infiltrated with leucocytes, and some observations, seem to indicate that this inflammation contributes more to the lung injury than the organisms themselves. Chest radiography usually demonstrates diffuse bilateral infiltrates, described as “ground glass infiltrates”. PCP typically presents with fever, fatigue, non-productive cough and tachypnea, evolving to dyspnea and cyanosis. The symptoms usually progress slowly over weeks to months. However, in patients without HIV, the disease can have a more acute and rapid onset, developing over days, although they tend to harbour less organisms in the lungs than do AIDS patients (99, 161, 165). Diagnosis is based on identification of *P. jirovecii* in bronchopulmonary secretions, primarily induced sputum or bronchoalveolar lavage (BAL), by staining of the organisms or by PCR detection of their DNA (30, 58, 176). Untreated, the infection is fatal due to a progressive asphyxia (suffocation). The first drug of choice for both treatment and prophylaxis of PCP is trimethoprim-sulfamethoxazole, given either intravenously or orally. One of the few alternative drugs is still pentamidine. Primary prophylaxis should be given to HIV infected patients with CD4+ cell counts of <200 cells/ $\mu$ l. Primary prophylaxis should also be given to all solid organ transplant recipients during a period of at least six months. Prophylaxis is also recommended for high risk groups such as patients undergoing stem cell transplantation, with acute lymphatic leukaemia, lymphoproliferative diseases treated with T-cell suppressing drugs or high dose steroids, and children with primary immunodeficiency with a T-cell dysfunction (30, 118). Secondary prophylaxis is given after PCP infection for six months, or until the underlying immunosuppression has been corrected (30, 118). Mortality rates for HIV patients with PCP have been reported to be 10% to 20% during initial infection and increase to 60% if the patient needs mechanical ventilation (45, 164, 193). Among other patients with PCP, the mortality rates lie between 30% to 60%, with a greater risk among patients with cancer (164, 193). Extra-pulmonary infections are rare, but have been described and result from dissemination of the infection from the lungs to other organs (42, 190).

### 1.3 PNEUMOCYSTIS JIROVECI

#### 1.3.1 Fungus versus protozoon

From the beginning it was thought that *Pneumocystis* was a protozoal organism, due to its morphological appearance and the response to the antiprotozoal drug, pentamidine. Today it is known that the organism is related to fungi rather than protozoa. This reclassification was initially based on several independent findings made in the late 1980s and early 1990s. For example, the ribosomal RNA of *Pneumocystis* is more related to those of fungi than to protozoa (57, 183), and that mitochondrial gene sequences also show homology with fungal DNA (154, 201). All recent phylogenetic analyses also place *Pneumocystis* within the fungal kingdom. The *Pneumocystis carinii* genome project confirms the homology of *Pneumocystis* to fungi (46, 48, 49, 156). *Pneumocystis* is now classified within the phylum Ascomycota, in a unique class, order and family (Pneumocystidomycetes, Pneumocystidales, Pneumocystidaceae, respectively) with the fission yeast *Schizosaccharomyces pombe* as the closest relative (115, 192). Today, considered belonging to the kingdom of fungi, *Pneumocystis* remains an atypical fungus with several unusual features. For example, the organism is unable to grow *in vitro* in fungal culture media, it responds to antiparasitic agents and the cell wall contains cholesterol rather than ergosterol unlike other fungi (89), and is therefore resistant to the typical antifungal drug amphotericin B.

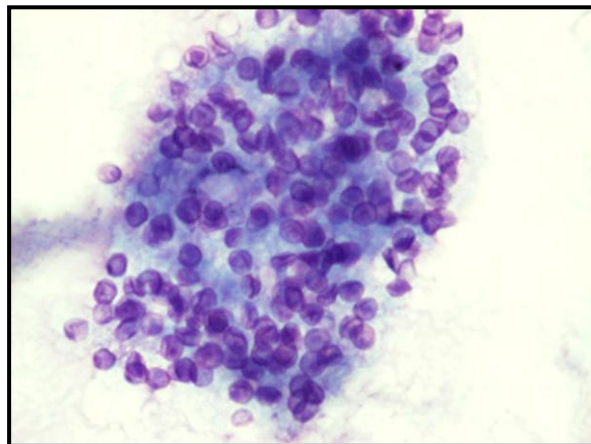

**Figure 1.** *Pneumocystis jirovecii* cysts recovered from lung alveoli stained with Toulidine Blue. Photo by Marianne Lebbad.

### 1.3.2 Host specificity

Several different species of *Pneumocystis* exist. Historically it was speculated that *Pneumocystis* causing disease in humans was a zoonosis, but now it is clear that the fungus is host specific. A unique *Pneumocystis* species has been identified in about every mammal investigated; humans, rats, mice, rabbits, dogs, ferrets, rhesus macaques etc. Each of the species has diverse genetics and stringent host specificity (52, 62, 67, 192). Earlier, all species of *Pneumocystis* were denoted *Pneumocystis carinii* and the different ones infecting different hosts were designated with the forma specialis (f.sp). For example, *Pneumocystis carinii* f.sp *carinii* was the form that infects rats, *Pneumocystis carinii* f.sp *murina* was the form infecting mice and *Pneumocystis carinii* f.sp *hominis* the form infecting humans. There has now been a name change and the *Pneumocystis* species infecting humans is denoted "*Pneumocystis jirovecii*", after the Czech pathologist Jirovec, one of the first to describe the organism in humans (63, 179). The form in rats (*Rattus norvegicus*), first described by Antonio Carini, has retained the name "*Pneumocystis carinii*". Three more species have been formally described; *P. wakefieldiae* also infecting rats (*Rattus norvegicus*), *P. murina* in mice (*Mus musculus*) and *P. oryctolagi* in rabbits (*Oryctolagus cuniculus*) (47, 52, 93).

### 1.3.3 Challenges

Still there is no *in vitro* model for cultivating *Pneumocystis* in the laboratory, which of course is hampering the studies on this organism (82, 175). Currently, infected animal models remain the main source of organisms for laboratory studies. A complication with this, as described previously, is that the different species of *Pneumocystis* are host specific and not able to infect another mammal. Therefore, no animal model exists for *P. jirovecii*. The genome of *P. carinii* has been sequenced (156), but no genome for *P. jirovecii* is available yet. Most of the knowledge we have on the biology of *Pneumocystis* are generated in animal models. The majority of this can probably be extended to the biology of the human form *P. jirovecii*, although one has to consider that both phenotypic and genotypic differences exist between the different species described (33). To study *P. jirovecii*, the main source of organisms are clinical respiratory samples as BAL, sputum, tracheal/bronchial aspirate and in special cases, transbronchial and open or autopsy lung biopsies. Since the *P. jirovecii* organisms collected from these samples cannot be taken for cultivation *in vitro*, or in animal models, investigations are restricted by these circumstances.

### 1.3.4 Genotypes

No functional or morphological means for determination of phenotypic diversity of *P. jirovecii* exist. To date, investigations on the epidemiology of this pathogen rely on application of molecular typing techniques. Several different typing systems, at different loci in the *P. jirovecii* genome, have been described for strain characterization. These genetic loci include the mitochondrial large subunit rRNA (mt LSU rRNA) (200, 202), the major surface glycoprotein (MSG) (66), cytochrome b (CYB) (204),

dihydropteroate synthase (DHPS) (119), dihydrofolate reductase (DHFR)(119) and the internal transcribed spacers (ITS) (108, 109, 116, 195). The mt LSU rRNA and ITS loci are frequently used because they are assumed not to be under genetic selection, and are therefore useful for studies on molecular evolution in circulating strains. The nucleotide sequence of the ITS1 and ITS2 regions, which in *P. jirovecii* exists as single copy DNA, shows the highest level of diversity and is considered to be the most discriminatory DNA loci for genotyping. The ITS1 region is located between the conserved genes encoding the 18S and 5.8S and ITS2 between 5.8S and 26S on the nuclear ribosomal RNA complex. These noncoding loci are spliced during rRNA biogenesis. Today, up to 100 different ITS haplotypes, i.e. the combination of ITS1 and ITS2, have been reported from 15 countries in Europe, America, Africa, Asia and Australia, with some globally common as well as some locally existing types (70, 79, 109, 126, 149, 150, 159, 173, 194, 208). Infections with more than one strain at a time have also been shown to be quite common. The ITS types have been useful when investigating outbreaks, subclinical colonization and the epidemiology of PCP. Whether certain genotypes have an epidemiological implication is still unclear. Alternative typing systems using multilocus genotyping have also been described (59, 200), and could be an alternative for *P. jirovecii* strain characterization.

### 1.3.5 Life cycle

There are two visible life cycle forms in the lungs of infected hosts: the trophic form and the cyst form with intracystical bodies. The terms “trophozoite” and “cyst” remain from the time when *Pneumocystis* was thought to be a protozoon, while the correct fungal nomenclature would in fact be “trophic cell” and “ascus”, respectively. Because of the difficulties with an *in vitro* system, these forms have been identified by morphological criteria and are found extracellular in the lungs of infected hosts. Trophozoites are 1-4 µm in diameter and mature cysts, 8-10 µm. During infection of the lung, there are more trophic forms than cysts (~ 10:1) (192) and most of the trophic forms are haploid (221). Three intermediate cyst stages have been visualized by electron microscopy, with 2, 4 and 8 nuclei, respectively (127, 223).

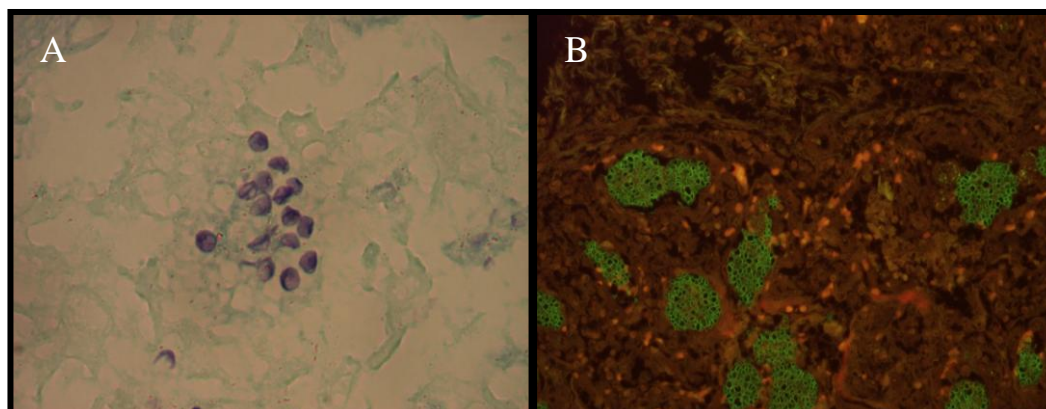

**Figure 2.** *Pneumocystis jirovecii* cysts in a lung section stained with Toulidine Blue (A) and immunofluorescence (B).

*Pneumocystis* is proposed to reproduce by two life cycles (Figure 3). One life cycle when the throphozoites reproduce asexually by binary fission and the other one is the sexual cycle when two trophozoites conjugate to form the cysts and undergo meiosis and subsequently mitosis. As the mature cyst ruptures, eight new trophozoites emanate from the intracystical bodies. Many genetic factors involved in meiosis and mitosis regulation, as well as genes or proteins potentially involved in both sexual and asexual replication have been identified (2, 33). Hence, *Pneumocystis* seems to resemble other ascomycotic fungi.

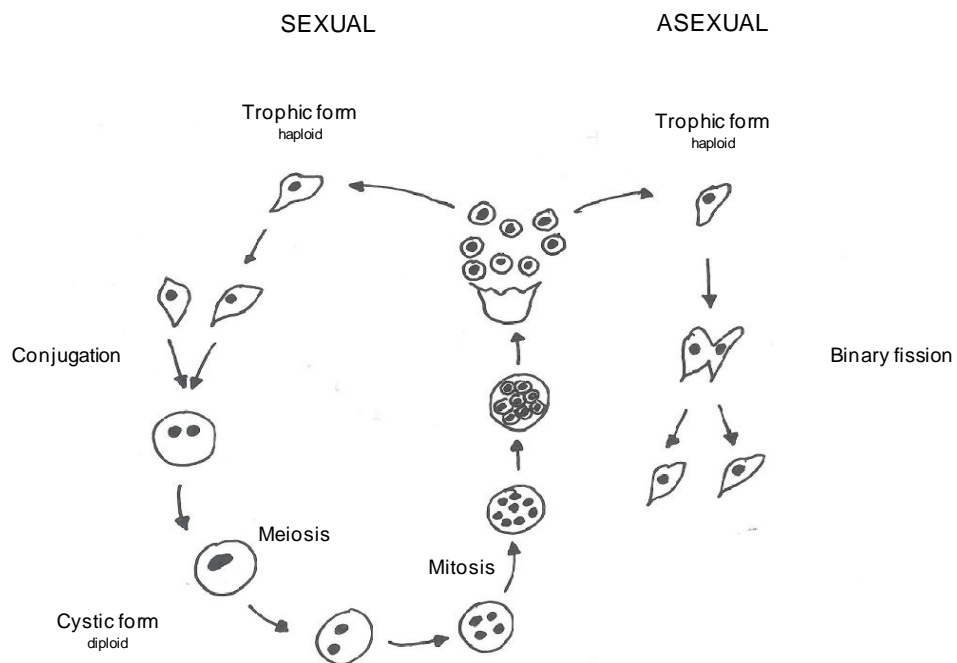

**Figure 3.** The proposed life cycle of *Pneumocystis*.

## 1.4 PNEUMOCYSTIS – HOST INTERACTIONS

### 1.4.1 Interactions with lung cells of the host

In an infected host, *Pneumocystis* resides in the alveoli of the lungs. The organisms adhere tightly to type I pneumocytes (205) and usually do not invade the host cells. This binding is facilitated by the interaction of fibronectin and vitronectin that bind to the surface of the *Pneumocystis* organisms and mediate the attachment to integrin receptors present on the pneumocytes (82, 114). The attachment of *Pneumocystis* inhibits the growth of the lung epithelial cells without destroying the cells (15, 110) and is thought to be required for proliferation of the trophozoites (97, 112, 193). Surface molecules, such as  $\beta$ -glucan and major surface glycoprotein (MSG), in the cell wall of *Pneumocystis* appears to be important factors for the initiation of an inflammatory response during the infection (192). The interaction of the fungus with pneumocytes and alveolar macrophages initiate numerous cascades of cellular responses in both *Pneumocystis* and in the lung cells. The host immune response involves complex interactions between alveolar macrophages, T-lymphocytes and neutrophils.

### 1.4.2 Immune response by the host

#### 1.4.2.1 Macrophages and innate immunity

Alveolar macrophages play an important role in the clearance of the *Pneumocystis* organisms from the lungs (101, 102, 106, 111). Macrophages can bind and phagocytose the organisms through the interaction of the mannose receptor of the macrophage and the *Pneumocystis* major surface glycoprotein (MSG), as well as the interaction of macrophage dectin-1 receptor with glucans in the *Pneumocystis* cell wall. This uptake may be facilitated by IgG-opsonization. When the fungus is taken up by the macrophage, it is incorporated into the phagolysosome and degraded (192). These studies have been performed in animal models where the clearance of *Pneumocystis* was shown to be markedly impaired in macrophage-depleted rats (111). Such a mechanism is also likely to occur in humans infected by *P. jirovecii*. In addition to their phagocytic role, and their ability to present antigens, macrophages produce a large variety of proinflammatory cytokines and chemokines, such as, TNF- $\alpha$ . TNF- $\alpha$  plays a major role in the clearance of the fungus during the infection (40, 78, 96), such as promoting the recruitment of neutrophils, lymphocytes and monocytes to the site of infection. These immune cells are crucial for the elimination of *Pneumocystis*, however, the release of oxidants, cationic proteins and proteases by these same cells can also damage the lung cells. Indeed, the number of recruited neutrophils has been shown to correlate with lung injury in humans and severity of PCP (9, 19, 113).

#### 1.4.2.2 Lymphocytes and adaptive immunity

Essential for the defence against *Pneumocystis* are the CD4+ T-lymphocytes. They are recruited and activated by TNF- $\alpha$  and interleukin-1 (17, 20, 73, 82, 160). The risk of



infection in humans substantially increases with a CD4<sup>+</sup> count of <200 cells/ $\mu$ l and treatment of HIV patients with HAART that replete the T-cells, decreases the risk of PCP in these individuals again. Several investigations in animal models support the fact that the lack of CD4<sup>+</sup> T-cells is a prime mean by which individuals develop PCP (82). CD4<sup>+</sup> T-cells coordinate the host inflammatory response by recruiting and activating additional immune effector cells that eliminate the *Pneumocystis* organisms. T-cells are necessary for clearance of infection but additional investigations have also shown that the T-cell response can also lead to significant pulmonary impairment during disease (16, 20, 165, 220). CD8<sup>+</sup> T-lymphocytes may also have a role during inflammation but, whether or not CD8<sup>+</sup> cells directly contribute to the defence (14, 20) or just cause lung injury (16, 220), is not yet clear. B-lymphocytes may also participate in the clearance of the fungus during infection (117). Healthy members of the general population show a high prevalence of serum antibodies to *P. jirovecii*, and some studies have shown that these antibody titers rise with a clinical PCP, and decrease in between two episodes of disease (152, 206). The role of B-cells has been proposed not only to be the production of antibodies, but also to regulate the CD4<sup>+</sup> immune response by antigen presentation during *Pneumocystis* infection (117). Further studies will provide more information about the significance of the role played by the B-cell in the host immune response to this organism. An effective elimination of *Pneumocystis* from the lungs, without adverse consequences for the host, may reside in an adequate balance between pro- and anti-inflammatory immune responses.

### 1.4.3 Transmission

Almost all children at two years of age are already seropositive to *Pneumocystis* antigens (129, 133, 152, 153). This indicates frequent exposure to the organism. This primary infection is either asymptomatic or manifested as a self-limiting upper respiratory tract infection (105). This high prevalence of seropositivity in children is one of the reasons why *P. jirovecii*, historically, was thought to colonize individuals early in life, establishing a latent infection that eventually caused PCP when the person's immune system failed. However, now both animal and human studies have shown that the fungus is eliminated after infection (39, 151), and the theory of reactivation of latent infection is no longer valid. At present, animal models and human studies favour an airborne transmission route for infection and PCP. Several outbreaks of PCP in immunosuppressed patients have been reported and molecular analyzes have shown nosocomial infections (7, 22, 38, 51, 76, 77, 158, 163, 172). Humans are most likely the reservoir and the source for transmission with an airborne person-to-person spread, although acquisition from environmental sources cannot be completely ruled out. Recent data also indicate that transplacental transmission may be possible (142). PCP patients are most likely not the only human source for transmission. The role of asymptomatic carriers and colonization is also being considered important for transmission of *P. jirovecii*. Colonization and clearance of *P. jirovecii* has been demonstrated in humans (34), and many reports have now shown that *P. jirovecii* DNA can be detected in the respiratory tract in humans without clinical PCP. Some groups of adult patients seem to be at higher risk of *P. jirovecii* colonization. HIV infected

patients are at higher risk, including those receiving PCP prophylaxis (81, 143, 157, 200). Another high risk group is patients with chronic lung diseases (26, 144, 155, 170, 171, 215). Smoking also increases the risk of *P. jirovecii* colonization and infection (135, 136, 143, 215). Colonization has also been shown in patients with diabetes mellitus, multiple myeloma, chronic lymphoid leukemia, sarcoidosis and asthma (148). Corticosteroid treatment and pregnancy also seem to facilitate colonization (123, 214). Even colonization in healthy individuals is now also under consideration. Transmission from PCP patients leading to *P. jirovecii* colonization in immunocompetent health care workers has also been shown (138, 213). The high seroprevalence of antibodies to *P. jirovecii* in children, and the detection of *P. jirovecii* DNA in healthy children, suggest that colonization occurs more frequently in children (212). Even the general adult population could potentially be a source of infection. Immunocompetent individuals usually clear the infection of *P. jirovecii* but they may transmit the organisms before they have fully eliminated them. The prevalence of colonization in a healthy population has been demonstrated to be 20% (128), although this high prevalence does not seem to be ubiquitous (147). In conclusion, PCP patients, patients colonized without symptoms of pneumonia, young children, and even healthy adults carriers are all possible sources of transmission of *P. jirovecii*. For as long as they remain infected, they may transmit the organisms either to other transient carriers or immunosuppressed persons at risk of developing PCP.

#### **1.4.4 Escape from the human immune response**

##### *1.4.4.1 Antigenic variation*

*Pneumocystis* is believed to harbor a system for antigenic variation as a mean to escape the immune response by the host. The phenomenon of antigenic variation is the ability of a pathogen to systematically change the antigens that are exposed to the immune system of the host so that the host does not recognize it and therefore cannot eliminate it (53). This hypothesis fits well with the model of *Pneumocystis* colonization of healthy persons or immunocompetent patients. Individuals with a functional immune system will immediately mount a strong immune reaction against invading *Pneumocystis* organisms. This immune response would target antigens on the cell surface of the organisms and eliminate them from the lungs. Many reports, both from animal studies as well as from studies on *P. jirovecii*, indicate that *Pneumocystis* can generate antigenic variants to evade the immune response. Antigenic variation can be generated by different mechanisms, such as phase variation or alternate expression of different antigenic variants of a given surface molecule. Many organisms rely on switching members of a gene family to alter their appearance. These gene families make up the holding tank of antigenic variants that lead the immune system on “wild goose chase”. For example, the bacteria *Borrelia hermsii* and *Neisseria gonorrhoeae*, the protozoan parasites *Trypanosoma brucei*, *Plasmodium sp.*, *Giardia lamblia* and *Babesia bovis*, as well as the fungi *Candida albicans* and *Candida glabrata*, all have multicopy gene families in their genome as a mechanism to vary their surface proteins to avoid immune recognition (3, 10, 12, 53, 61, 132, 146, 184, 189). In *Pneumocystis*, a

multicopy gene family has been identified that encodes the major surface glycoprotein (MSG) (66, 100, 181, 182, 186, 197). The MSG proteins are supposed to be involved in various biological functions including antigenic variation.

#### 1.4.4.2 Major Surface Glycoprotein (MSG) gene family

In *Pneumocystis*, *P. carinii* has been the primary model for studies on antigenic variation, but some information regarding the other species, including *P. jirovecii*, is also available, as reviewed in (178, 180). The MSG is an important cell-surface molecule and most likely the key player in immune evasion and colonization of the host. The MSG is the most abundant protein expressed on the surface of *P. jirovecii*, with molecular masses ranging from 95-120 kDa. MSG appears to act as an attachment ligand to the alveolar pneumocytes and is a target of both humoral and cellular immune responses by the host. The *msg*-gene family consists of up to 100 copies located in the sub-telomeric regions of all chromosomes (95, 100, 180, 185, 186, 196, 197). Transcription is probably limited to a single *msg*-gene, at a given time, and the active copy is found in a unique expression-site located at a specific telomere-end (185). The expression-site contains a transcriptional promoter, the upstream conserved sequence (UCS) with a translational start codon, and an attached variable *msg*-gene. The expression-site, including the UCS is present only once in the genome (56, 185, 199) and therefore probably only one MSG protein can be expressed at any time in a single organism, whereas all the other members of the *msg*-gene family remain silent. The UCS encodes a putative signal-peptide and an invariant part that is removed, en route, to the surface of the organism (56, 180, 199). A conserved recombination junction element (CRJE), present at the 3'-end of the UCS, encodes the amino acids MARPVKRQ, including a site putative for protease cleavage which may be the mechanism for how the UCS is removed from the mature antigen. This CRJE is also present in the 5'-end of all the silent *msg*-copies in the genome and may act as the upstream integration point for silent copies into the expression site. Recombination may play a role in generating further *msg* diversity (94, 104, 178, 198) including genetic exchange between different paralogous copies resulting in mosaic genes. *Msg* gene families with similar organization have been identified in *P. carinii*, *P. murina*, *Pneumocystis* from ferret and *P. jirovecii* (56, 71, 103, 219). The MSG gene family, with its restricted expression and ability to generate immense diversity, has the potential of being an antigenic variation system to avoid immune recognition and elimination by the host.

## 1.5 DRUG RESISTANCE

As mentioned before, widespread prophylaxis and treatment for *P. jirovecii* with sulfa-containing drugs have effectively decreased the incidence of PCP. Trimethoprim-sulfamethoxazole (TMP-SMX) is the most effective and widely used drug for prevention and treatment. Sulfamethoxazole is considered to be the active agent against *P. jirovecii* and is a structural analogue of para-aminobenzoic acid (pABA). pABA is the natural substrate of the enzyme 6-hydroxymethyl-7,8-dihydropteroate

synthase (DHPS), an essential component of the folate synthesis pathway (174). The action of sulfamethoxazole is to competitively inhibit DHPS (124).

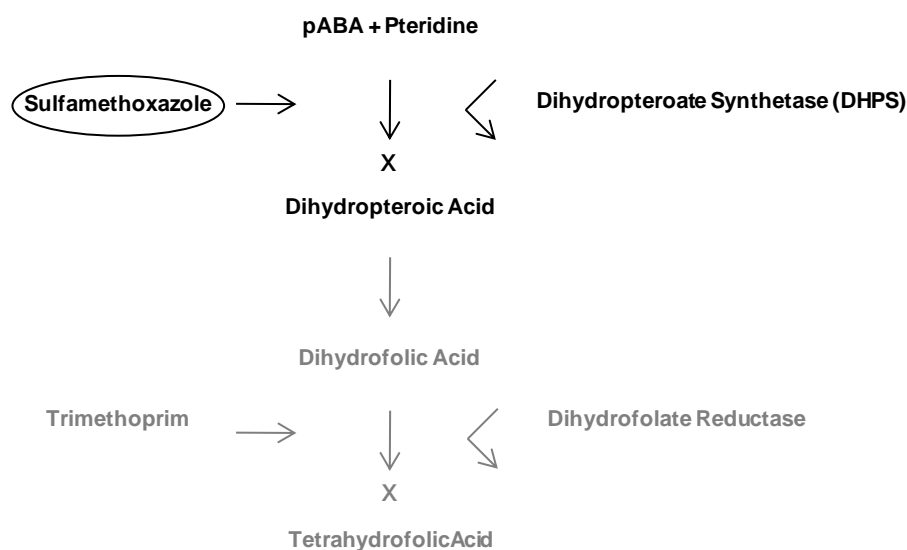

**Figure 4.** Inhibition of folate synthesis by sulfamethoxazole and trimethoprim. Modified from Masters *et al.* (124).

In *P. jirovecii*, two nonsynonymous point mutations in the *fas* gene, which encodes the DHPS enzyme, are associated with prior exposure to sulfa drugs (44, 74, 80, 91, 120, 145, 217). These mutations, at nucleotide positions 165 and 171, cause the amino acid substitutions Thr55Ala and Pro57Ser in the DHPS protein and are assumed to lead to structural changes in the active site of the enzyme resulting in decreased affinity for the sulfa derivate and reduced inhibitory activity (Figure 5). Concerns have now been raised if these mutations are the result of *P. jirovecii* developing resistance to sulfa drugs (177). Point mutations in the DHPS-encoding genes of microorganisms such as *Plasmodium falciparum*, *Staphylococcus aureus*, *Mycobacterium leprae*, and *Escherichia coli* have been shown to confer resistance to sulfonamides (50, 72, 88, 211). The prevalence of *P. jirovecii* DHPS mutations reported from different countries ranges widely, from 0% to 81% (4, 5, 13, 43, 44, 55, 60, 64, 74, 83, 92, 107, 145, 187, 203, 208, 216). As *P. jirovecii* cannot yet be cultured, conventional *in vitro* susceptibility tests cannot be utilized and studies of drug resistance in this organism rely on the use of genetic markers and suitable models. Functional complementation of either DHPS-disrupted *Escherichia coli* with a mutant *P. jirovecii fas* gene or FOL1-disrupted *Saccharomyces cerevisiae* with the *fol1* gene mutated at position analogous to position 165 and 171 in *fas* results in the loss of susceptibility to sulfa (86, 131). Many studies are now supporting the suspicion that *P. jirovecii* is developing resistance to the drugs but the confirming evidence of DHPS mutations associated with treatment failure is still lacking since a number of studies have shown contradictory results and more studies are therefore needed (4, 74, 91). Even with some key evidences missing, many

findings are now pointing towards the fact that *P. jirovecii* is developing resistance to sulfa-containing drugs which is of major concern.

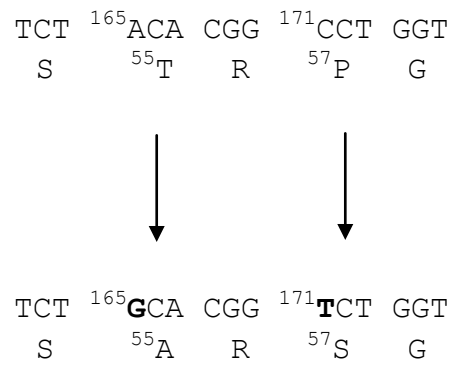

**Figure 5.** Non-synonymous mutations at codon 55 and 57 in the *P. jirovecii* DHPS gene.

## 2 SCOPE OF THE THESIS

When we started these studies there were many relevant questions regarding epidemiology, susceptibility to drugs and pathogenesis concerning *P. jirovecii* and PCP that needed and still need to be answered. There was no knowledge about the strains causing PCP in Sweden, and whether epidemiological relationships between episodes of clinical *P. jirovecii* infections existed in the country. Not much was either explored concerning the identification of genetic markers of virulence. The fact that different *P. jirovecii* genotypes exist had led to speculations that some genotypes may be more pathogenic or more transmissible than others. The identification of the *msg*-gene family, with its restricted expression pattern, had also introduced the theory that the fungus is undergoing antigenic variation as a mean to evade the host's immune system. Further, evidence had been gathered suggesting that the fungus is developing resistance to sulfa-containing drugs, and that the resistance is associated with mutations, but nothing was known about how common these mutations were among strains circulating in Sweden. An important aspect within this field is the lack of an *in vitro* culture system, and the fact that there are no morphological means for the determination of *P. jirovecii* strains, which is impeding the studies.

### Specific aims

To approach some of the above-mentioned questions different loci of the *P. jirovecii* genome was targeted. We chose three loci; the Internal Transcribed Spacers (ITS) in the nuclear ribosomal DNA gene complex, the Dihydropteroate Synthase (DHPS) gene and the Major Surface Glycoprotein (MSG) gene family with the following objectives to study:

- I. The epidemiology and genetic diversity of *P. jirovecii* in Sweden.
- II. The relevance of the ITS strain characterization system.
- III. The prevalence of *P. jirovecii* DHPS mutations in Sweden.
- IV. The antigenic variation of the MSG-gene family.

## **3 EXPERIMENTAL PROCEDURES**

Here follows a short description of the material and methods used in the studies. All experimental procedures are described in detail in the different papers that this thesis is based upon (I-IV).

### **3.1 ETHICAL APPROVALS**

An ethical approval for using the specimens in these studies was obtained from the ethical committee of Karolinska Institutet.

### **3.2 SPECIMENS**

Bronchoalveolar lavage (BAL), bronchial aspirate and sputum specimens from patients with suspected PCP were collected as part of routine diagnostic procedures at different clinical centra in Sweden between 1996 and 2003. *P. jirovecii* infection was assessed in all cases by both immunofluorescence and by PCR at the Swedish Institute for Communicable Disease Control (SMI) in Stockholm. The specimens were mixed with DTT to dissolve the samples and ethanol was added for the inactivation of HIV. DNA from the specimens was extracted with the purification system QIAamp DNA Mini Kit (QIAGEN) as part of the routine diagnostic analysis.

### **3.3 MOLECULAR PROCEDURES**

#### **3.3.1 Real-time PCR for detection of *P. jirovecii***

Real-time PCR targeting the large ribosomal subunit (LSU) of *P. jirovecii* is conducted as a routine diagnostic analysis of PCP at SMI, and is described in detail in Paper I.

#### **3.3.2 PCR amplification**

PCRs, single or nested, of the different loci were either conducted according to an existing protocol previously published, or newly designed for this study. All PCRs are described in detail in the different Papers.

#### **3.3.3 Cloning and sequencing of PCR products**

The PCR products from the different genes (Paper I, Paper II and Paper IV) were cloned into the pCR<sup>®</sup>2.1-TOPO<sup>®</sup> plasmid vector using the TOPO TA Cloning kit (Invitrogen). The selected bacterial colonies were screened with M13 vector-specific primers by PCR, described in detail in the Papers. Recombinants were sequenced from both directions using M13 primers and dye terminator chemistry at the core facility of SMI or at Agowa GmbH, Germany. The PCR products from the full length UCS-msg amplification (Paper IV) were purified and cloned into the pCR<sup>®</sup>-XL-TOPO<sup>®</sup> plasmid using the TOPO XL PCR Cloning Kit (Invitrogen). The selected bacterial colonies

were screened with a forward M13 vector-specific primer and a reverse primer targeting downstream the insert by PCR, described in detail in Paper IV. Colonies were cultured over night in LB media including kanamycin and the plasmids were purified with the Quantum Prep Plasmid Miniprep (Biorad). For confirmation of long inserts the plasmid preparations were amplified with M13 vector specific primers. Five plasmids from each specimen with long inserts were sequenced in both flanks by M13 primer and BigDye Terminator reaction to confirm the identity of the insert. One clone from each specimen was completely sequenced with dye terminator chemistry from both directions by primer walking at Agowa GmbH, Germany.

### **3.3.4 Sequencing by pyrosequencing technology**

Pyrosequencing (Biotage), which is a sequencing-by-synthesis technique is a fast and accurate sequencing method for short DNA sequences and was chosen for sequencing of the polymorphic positions in the DHPS region (Paper III). The PCR product generated in the nested PCR was biotinylated at one strand and ~160 bp long which is suitable for this method. The PCR products were prepared for pyrosequencing analysing using a dedicated vacuum prep workstation (Biotage) and processed for sequencing analysis in a PSQ96 MA (Multi-Application) using the PSQ96 SQA Reagent Kit (Biotage) as described in detail in Paper III.

## **3.4 ANALYSES**

The sequence inserts obtained from the various PCRs were edited and analyzed with the BioEdit Sequence Alignment Editor (version 7.0.4.1). Sequence alignments were performed using the ClustalW software (Paper II) or the MAFFT sequence alignment tool (Paper IV, (90)) with default settings. Phylogenetic trees were constructed by the Neighbor Joining method with the MEGA3.1 (Paper II) or MEGA5 (Paper IV, (188)) software. In order to estimate robustness, bootstrap proportions were computed after 1000 or 500 replications. Genealogical relationships (Paper II) were constructed with the TCS software (41), using the algorithm of Templeton *et al.* (191). Identities and similarities (Paper IV) were calculated with the Matrix Global Alignment Tool (MatGAT, (27)). Statistical analyses were performed using SigmaStat software (Paper I) or Stata 9.2 software (Paper II and Paper IV). Data were analysed statistically using the nonparametric Mann-Whitney rank sum test (Paper I and Paper IV) or the chi-square and *f*-test (Paper II). *p*-values of <0.05 were considered significant. Diversity (Paper II) was calculating using the Shannon-Weiner (167) and Simpson (169) diversity indexes, which are dependent on richness (number of different types) and evenness (how many of each type).



## 4 RESULTS AND DISCUSSIONS

### 4.1 EPIDEMIOLOGY AND GENETIC DIVERSITY OF *P. JIROVECI*

#### Paper I and Paper II

To study the biodiversity of *P. jirovecii* in Sweden 64 specimens, eight specimens per year, collected during the years 1996 to 2003 were chosen for the analysis. The specimens' DNA were amplified with a nested PCR as described by Lee *et al.* (109) for the internal transcribed spacers (ITS), subsequently cloned and sequenced. In total 408 sequences were analyzed and compared to already established genotypes and haplotypes, i.e. the combination of ITS1 and ITS2 genotypes. Overall, 41 different haplotypes were found in the clinical material. The result also showed that many of the specimens were co-infected with more than one haplotype and among these co-infected specimens there were sequences that we thought were recombinants. These recombinants were seen as rare haplotypes that appeared to be the combination of more common haplotypes also present in the same specimen (Figure 6). Even though a sexual replication cycle in *Pneumocystis* probably exists, that could generate recombinants, the high frequency of the recombinants that we saw made us consider that some of these recombined haplotypes maybe had been generated during the genotyping procedure. It is well established that recombination, or chimera formation, can occur during PCR when the template is a mixture of similar sequences rather than a single target (134, 162, 168). This led us to further investigate if the ITS typing system commonly used was generating artifactual recombinants.

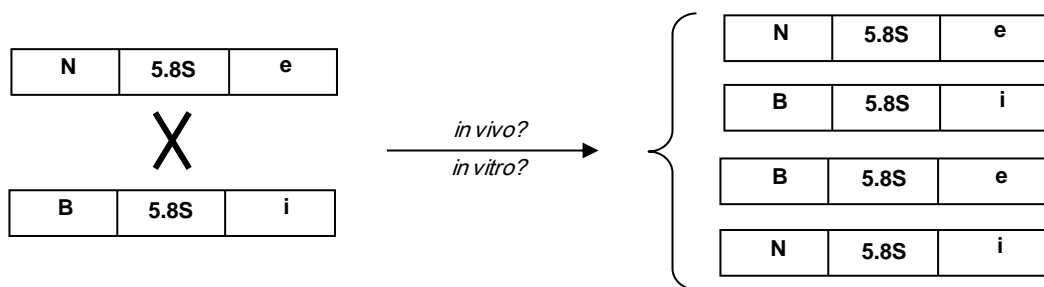

Figure 6. Recombination between two haplotypes within a specimen.

#### 4.1.1 *In vitro* recombination during ITS genotyping

##### Paper I

To answer the question whether the recombinant sequences we observed were indeed generated *in vitro* we started up by mixing specimens with known haplotypes and typing them according to the standard protocol (109). By mixing two single infected

specimens we could show that recombinant sequences of these mixed haplotypes also were generated during the typing procedure. We could show that up to 37% of produced sequences actually were artifactual DNA sequences. We further investigate at what step in the genotyping protocol these artifacts were produced, and showed that the recombinants were mainly generated during the PCR elongation step, but that a small amount also could be generated later on during the cloning step. Finally, we investigated if it was possible to suppress the chimera formation during the typing procedure. We tested several modifications of the standard protocol and found that the number of *in vitro* generated recombinants could be almost abolished by using longer elongation time, less cycles, higher denaturation temperature and higher primer concentrations during the PCR. In addition to the chimera formation, the ITS region seems to be more prone to misincorporations compared to another gene we tested. The implication of this is that artifactual haplotypes, as well as artifactual ITS1 and ITS2 genotypes, probably have been erroneously reported as new identified strains, when using the ITS genotyping system. Therefore, the diversity in *P. jirovecii* populations has in all likelihood previously been overestimated.

#### **4.1.2 Genetic diversity of *P. jirovecii* isolates**

##### **Paper II**

In the clinical material made up of the 64 respiratory specimens, 10 ITS1 and 12 ITS2 previously established genotypes were found. In addition to these genotypes a novel ITS2 sequence was found and denoted “v”, according to the nomenclature put forward by Lee *et al.* (109). Among the 41 haplotypes identified, nine were found in several specimens each and at least once as a single infection. Haplotype Eg was the most frequent one followed by Ne, Bi, Eb, Ai, Ea, Ec, Jf and Iv, the latter including the novel ITS2v. Since 50% of the specimens were co-infected with more than one strain, and considering our findings with respect to the *in vitro* generated recombinants, we made efforts to exclude potential artifacts from the more complex specimens. To differentiate between genuine and artifactual haplotypes we set up some criteria for the definitions of a “*bona fide*” haplotype. *Bona fide* haplotypes were defined as haplotypes that are found in single infections, or those that cannot have been generated by *in vitro* recombination from other haplotypes found in the same specimen. By these criteria three more haplotypes (Gg, Kf and Eh) were also considered genuine haplotypes albeit occurring at lower frequency. In conclusion, only 12 haplotypes defined the essential structure of the local population of *P. jirovecii* organisms in Sweden (Table 1).

**Table 1.** *P. jirovecii bona fide* haplotypes detected in Sweden.

ITS haplotype	Specimens (n=64)		Clones (n=408)	
	n	%	n	%
Eg	28	44	106	26
Ne	10	16	61	15
Bi	9	14	38	9
Eb	9	14	44	11
Ai	6	9	24	6
Ea	5	8	15	4
Ec	5	8	23	6
Jf	5	8	24	6
Iv (new ITS2)	4	6	17	4
Eh	1	1.6	2	0.5
Gg	1	1.6	3	0.7
Kf	1	1.6	2	0.5

It has been suggested that certain ITS haplotypes may be associated with patient demographics, or be more or less virulent than others (139, 208), but no such correlation has been established (75, 203). In an attempt to investigate if there was any association between haplotypes and other parameters we tested our material in this respect, but could not find any correlation between particular ITS haplotypes in co-infection cases and we detected no differences in age, sex or underlying condition of the patients. We also compared frequencies of the most common haplotypes in different regions of Sweden covered in this work, as well as those in every year during the time span of this study, but no geographical, temporal or seasonal clustering of haplotypes was observed. However, the numbers in these calculations are relatively small so the absence of correlations between certain haplotypes and clinical or demographic correlations does not necessarily mean that the correlation is missing, and more studies are therefore needed.

We also wanted to investigate the relationships between all major ITS types found worldwide, including those found in Swedish strains. In this analysis we included all *bona fide* haplotypes found in Sweden as well as sequences described in international studies that fulfilled our criteria of *bona fide* haplotypes, present at frequencies of >4%. The stringent inclusion criteria were chosen to be sure not to include potential artifactual haplotypes that could influence the results of the analysis. In total 27 haplotypes were included and among them 11 were locally existing types from Thailand (Ip, Ir and Rp), Japan (Fu<sub>4</sub>, Iu<sub>3</sub> and U<sub>1e</sub>), South Africa (Eu), Portugal (Pb), Australia (Isyd2), India (DEL1r) and the Swedish type Iv. At first we used classical phylogenetic approaches and constructed trees by Neighbor-Joining analysis with maximum parsimony and maximum likelihood algorithms. These trees only showed

weak bootstrap values and did not provide sufficient intraspecies resolution for haplotype grouping. Instead we tested if coalescence theory could be used in describing how *Pneumocystis* strains are related. Coalescent theory attempts to trace all alleles of a gene shared by all members of a population to a single ancestral copy, the most recent common ancestor, still present in the population. For this purpose we used the TCS (41) analysis software that uses haplotype frequency and parsimony to infer relationships between sequences. The same haplotypes as for the phylogenetic trees were included in the analysis but at frequencies corresponding the rates of the different epidemiological studies. The coalescent analysis showed that Eg occupies a central position in the population and that Eg represents the most recent common ancestor, which is consistent with other studies (70, 159, 208). The gene genealogy did not resolve all relationships but showed five groups of haplotypes or clades (Figure 7). There were no apparent differences between Swedish types and types from other origin, which precludes the establishment of a geographical pattern, and is consistent with the notion that most of the haplotype are present worldwide.

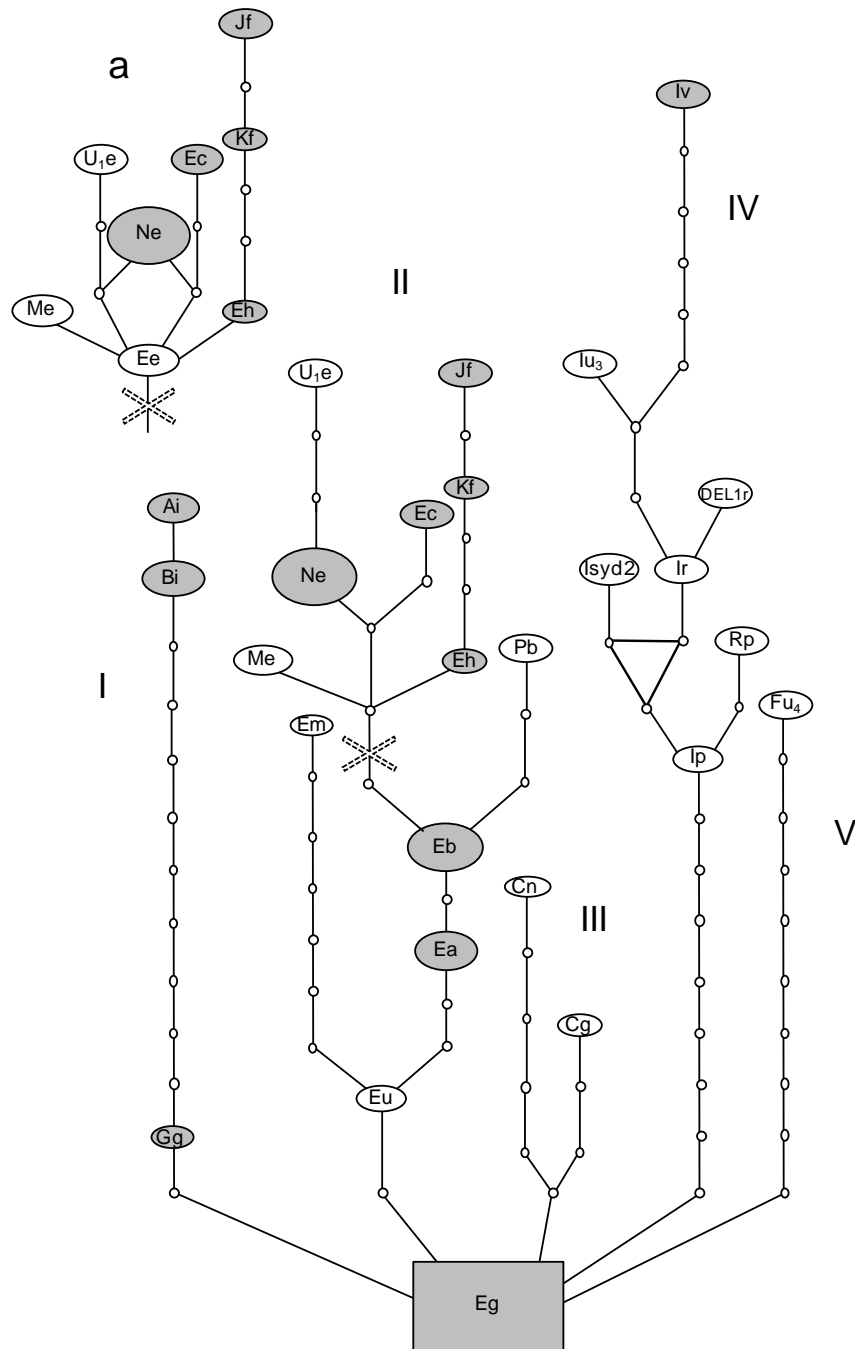

**Figure 7.** Genealogy of *P. jirovecii* ITS haplotypes. The network was derived by coalescent analysis using the TCS program. Lines connecting haplotypes are equivalent to one mutational difference. Empty nodes represent genotypes not found in the population. The size of ovals/square corresponds to haplotype frequency. The most likely recent common ancestor is depicted by a square (Eg). The introduction of haplotype Ee results in the relationships between types in clade II as shown in inset a. The types identified in Sweden are shown in gray.

There were two unresolved loops indicative of homoplasmy or recombination in the network. One of the loops is introduced in the network when haplotype Ee is included in the analysis. Haplotype Ee is a special haplotype since it satisfies the criteria for a *bona fide* haplotype, but is the combination of the two most common haplotypes worldwide (Eg and Ne). In our material we hypothesize that Ee is a recombinant generated *in vitro* but that is found more frequently due to the fact that the parental sequences are so common. However, this variant could also be the result of recombination during a sexual replication. Convergence could also be anticipated to explain the presence of Ee since the sequences are so closely related and is a possibility that cannot be dismissed (Figure 8). Anyhow, Ee is a haplotype that one should keep an extra eye on and elucidate further whenever it is identified in a clinical material.

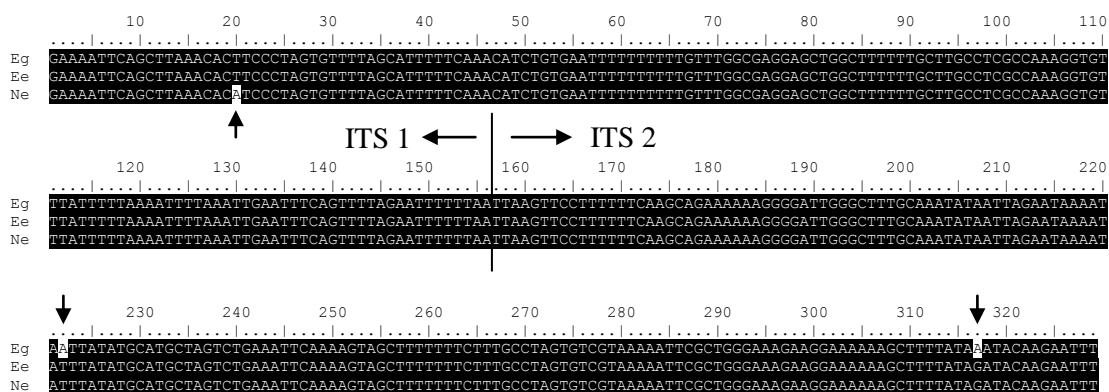

**Figure 8.** The relatedness of haplotypes Eg, Ne and Ee

Lastly we applied two different diversity indexes onto the material to investigate whether there was a difference in the diversity in Sweden compared to other countries, or if the diversity in Sweden had changed over time. Analysis of the Shannon-Weiner and Simpson Diversity indexes (167, 169), which are dependent on both richness (number of different types) and evenness (how many of each type), revealed no difference in Sweden compared to other countries.

### 4.1.3 Summary

The diversity of *P. jirovecii* has previously been overestimated due to the problem of ITS recombinants that are produced *in vitro* during the typing procedure. We elucidated this and made some changes to the standard protocol that suppresses the formation of these artifactual recombinants. We defined a set of criteria to discriminate genuine “*bona fide*” haplotypes from erroneous non-existing ones. In the Swedish material made up of 64 clinical respiratory specimens, 12 *bona fide* ITS haplotypes, consisting of 10 ITS1 and 12 ITS2 genotypes, were revealed, nine of which were common, recurring in several specimens. One new ITS2 sequence denoted “v” was found in four specimens. Half of the specimens were infected with more than one type. There were no associations between haplotypes and patient age, sex, underlying disease or

geographical origin, and no differences in diversity between Sweden and other countries based on Shannon and Simpson index analysis. We also presented a model depicting the genealogic relationships of *bona fide* ITS haplotypes existing worldwide.

## 4.2 PREVALENCE OF *P. JIROVECI* DHPS MUTATIONS IN SWEDEN

### Paper III

It has been suggested that *Pneumocystis* can develop resistance to sulfa drugs, and that this resistance is due to mutations at two positions in the *P. jirovecii* dihydropteroate synthase (DHPS) gene (177). The DHPS gene including the polymorphic positions is located within the *fas*-gene that codes for several components of the folate synthesis pathway (124, 217). We decided to investigate whether these mutations are prevalent in the clinical material from Sweden. The DNA of 103 randomly chosen clinical respiratory specimens, collected between 1996 and 2003, were successfully amplified for the *fas* gene, and included in the study. The patients had different underlying causes of immunosuppression; haematological diseases (30%), HIV (17%), inflammatory diseases (8%), solid tumors (8%), organ transplantation (2%) and other diseases (2%). A part of the DHPS region in the *fas* gene, including the polymorphic positions 165 and 171, was subsequently amplified and sequenced. All of the specimens (100%) showed a wild-type DHPS pattern. This suggests that there is no or a very low prevalence of DHPS mutations among *P. jirovecii* strains circulating in Sweden. This is a very low prevalence compared to other studies from different parts of the world. Only a study in Brazil has shown no DHPS mutations (216), but other countries have reported prevalence's ranging from 4% – 81% (5, 44). It is noteworthy that in Denmark, despite its geographical proximity to Sweden, a prevalence as high as 20% of strains that carry a mutated DHPS-gene have been reported (74).

*P. jirovecii* DHPS mutations have been associated with prior exposure to sulfa drugs in several studies (44, 74, 80, 91, 120, 145). Many of these studies were made exclusively in HIV positive patients. In our material only 17% of the patients were HIV positive, and it is possible that we would have found a higher frequency of mutations if the study had been conducted only on HIV patients. However, in Sweden there are a relatively low number of people living with HIV (0.06% of the Swedish population in the year 2009). Nevertheless, none of the 19 patients diagnosed with a HIV infection in the study carried a strain of *P. jirovecii* with a mutated DHPS-gene.

Extensively PCP prophylaxis or treatment with TMP-SMX alone is probably not the only cause leading to a high prevalence of mutant *P. jirovecii* strains. It has been postulated that a selective pressure exerted by sulfa-containing drugs to treat other infections than PCP contributes to the occurrence of *P. jirovecii* DHPS mutations (55). Hence, the absence of mutations in Sweden might be a result of the restricted policy of antibiotic management. In Sweden, TMP-SMX is not widely used to treat other diseases than PCP, which also is a quite rare disease, and the restricted use of this drug

probably contributes to the apparent absence of *P. jirovecii* strains carrying a mutant DHPS. It is also noteworthy that not all studies showing the highest prevalence of *P. jirovecii* DHPS mutations have the highest prevalence of patients on PCP prophylaxis (Paper III, Table 1). In fact, two studies with material from HIV patients from two different countries showed the same prevalence of patients being on prophylaxis (33%), but with DHPS mutations prevalence's of 81% and 17%, respectively (4, 44).

#### 4.2.1 Summary

The prevalence of mutant DHPS *P. jirovecii* strains in Sweden was very low. This low prevalence might be due to the low number of HIV patients in Sweden, and potentially the result of a restricted policy of antibiotic management.

### 4.3 THE ANTIGENIC VARIATION OF THE MSG-GENE FAMILY

#### Paper IV

The MSG is encoded by the *msg*-genes, which belong to a multicopy gene-family that are believed to exert antigenic variation. There is only one expression locus in the genome, where the *msg*-gene that is expressed is located; probably resulting in the MSG protein that is exposed on the surface of the organism (180). Little is known about the expression and variability of this gene-family of *Pneumocystis*, and in particular *P. jirovecii*. This has been in part due to the inability to obtain sufficient quantities of undegraded RNA preparations from human-derived organisms, and the lack of a culture system. We wanted to investigate the diversity of the *msg*-gene family in some of the clinical specimens. Since we were primarily interested in the expressed genes we designed a PCR amplification set-up targeting the *msg*-copy located in the expression site, excluding all the probably silent copies (Figure 9).

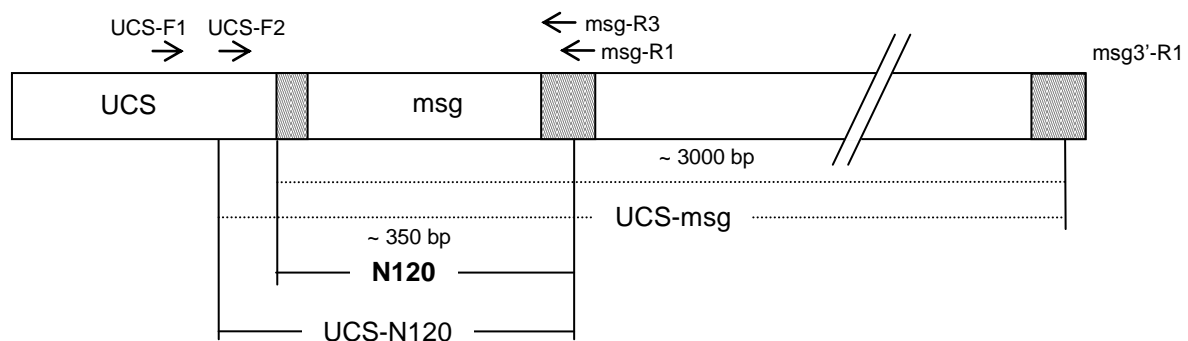

**Figure 9.** Schematic display of the experimental setup. The PCR allows exclusive amplification of the *msg*-genes translocated into the expression site. Horizontal arrows are depicting the primers. Striped boxes are showing conserved fragments downstream the Upstream Conserved Sequence (UCS).



### 4.3.1 N120 sequences

We started by choosing 12 clinical specimens that were known to be single infections, as defined by ITS typing. We chose other ITS haplotypes than Eg, which is by far the most common one, as a mean to approach clonal infections of *P. jirovecii* as possible. In addition, a multiple infected specimen was included in the study. These 13 specimens were amplified with a PCR generating an amplicon of ~ 430 bp, made up by 74 bp of the upstream conserved sequence (UCS) of the expression site and approximately 350 bp of the variable *msg*-gene. A total of 521 recombinant clones, 25 to 52 per sample, were sequenced and analyzed. Since we were interested in the *msg*-genes, we manually removed the UCS part of the sequence. The resulting 5'-region of the *msg*-gene, including the recombination junction element (CRJE), was denoted N120. The N120 nucleotide sequences generated from the 13 clinical specimens clustered into obvious groups. Within the groups there was some microvariation, up to 5 nucleotide differences per sequence. This variation can be either due to biological polymorphisms or due to PCR generated errors. To simplify further analysis, sequences with less than 5 differences at the nucleotide level were assembled into different sets denoted groups (455 sequences assembled into 57 groups). From each group the most common sequence was chosen for further analyses, and referred to as a "type sequence". The remaining 66 sequences were singletons occurring only once in a given specimen. In total, 123 type sequences and singletons were found in the material. In almost all of the specimens more than one N120 sequence were expressed, with a maximum of 18 sequences (7 type sequences and 11 singletons). Only one specimen contained one single N120 type sequence.

Interestingly, we also found out that some type sequences were present in more than one specimen. These sequences were denoted N120a-h. The N120a sequence was found in 4 different specimens (Paper IV, Figure 2). This sequence was found as two different variants with two single nucleotide polymorphisms (SNPs). All N120a clones within a specimen showed the same variant, therefore excluding the possibility that these sequences were generated by cross contamination of samples. These specimens were not related because they were collected from different patients, in different years and at different geographic locations. The N120b-h sequences were present in two specimens each. The finding of recurring sequences indicates that some N120 sequences are more frequently expressed than others. Expressing these more frequent *msg*-genes seems also to be a common feature since 10 out of 13 samples expressed at least one of the N120a-h sequences. Since identical type sequences occurred in more than one sample, the number of non-recurring sequences after removal of the duplicates was 50 unique type sequences. Surprisingly, several of the type sequences also corresponded to sequences that have been reported previously by Kutty *et al.* (i.e. Rucl2, Rucl5, Rucl10, Rucl18, Rucl22, Rucl25, Rucl38 and Rucl41 (104)).

In the material we could see what appeared to be evidence of recombination. Two examples of possible single cross over recombination events of N120 sequences, from two specimens are shown in Paper IV, Figure 6. Two more specimens showed evidence

of single cross-overs (data not shown), whereas another sample displayed no less than nine potential recombinational events (Figure 10). This multitude of recombinational events suggested that many of these are artifacts generated during the PCR-amplification. However, since it is likely that hybrid genes can be generated not only *in vitro*, but also as a result of biological processes, the recombinational event in the N120-segment should be further investigated before they are discarded.

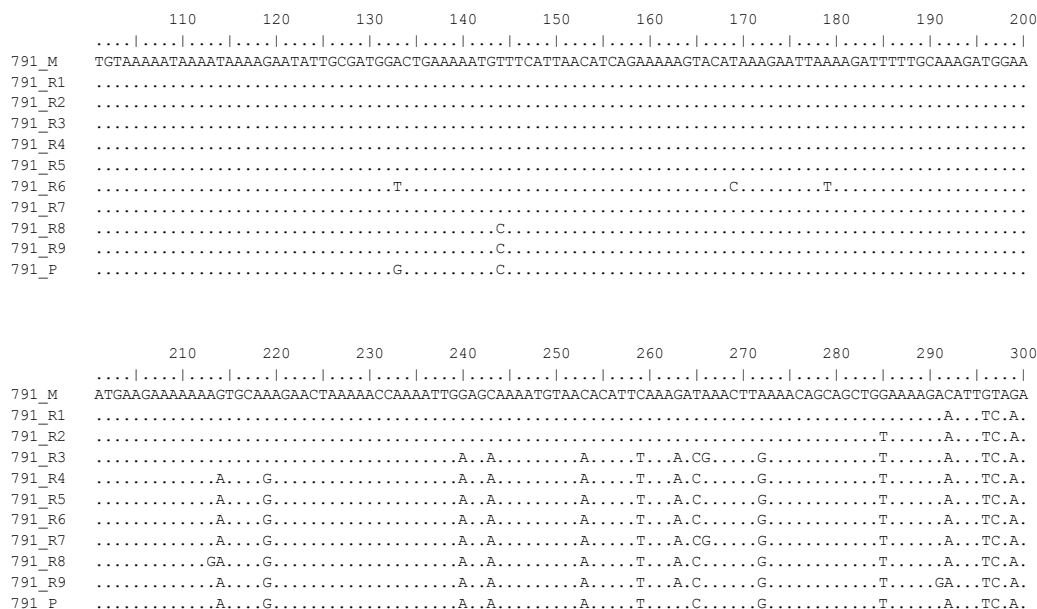

**Figure 10.** N120 recombinants found in one specimen. M and P refer to the parental sequences whereas R1 to R9 represent recombinant variants. The figure shows the gradual changes in difference between the parent “M” and parent “P”.

To further analyze the diversity of the N120-segment we looked at the pairwise identities of the sequences. In this analysis we included all the 57 type sequences. The reason to include duplicate sequences, 50 unique type sequences and the recurring N120a-h from each sequence, was to be able to compare differences within a specimen as well as all the sequences in the study. The average pairwise nucleotide identity was 69 %, ranging from 59 % to 100 %. Of the 57 nucleotide type sequences three could not be translated, probably PCR artifacts. The remaining 54 amino acid sequences had an average pairwise identity of 53 %, ranging from 37 % to 100 %, and a similarity of 71 %, ranging from 53% to 100%. In contrast to what we speculated, there was no statistical difference in the average pairwise identity between sequences within a specimen (intra) and sequences from different specimens (inter),  $p > 0.05$ . Finally we generated a model of the relationship between the N120-protein sequences by phylogenetic trees that were constructed by Neighbour-Joining analysis, but we did not see any particular grouping.

In conclusion, there was a high degree of variability in the N120-segment with no apparent grouping. Several type sequences occurred more than once. Some of the variants showed a high degree of homology to material from another published report

(104). The overall variation was higher at the protein level compared to the nucleotide level, which is to be expected. It was notable that the variability within a sample was as high as in the whole material.

### 4.3.2 Full length *msg* sequences

To further investigate the expressed *msg*-genes, we looked at two full-length genes located in the expression site. The same forward primers were used as for the N120-segment but a new primer at the 3'-end on the full-length *msg*-gene were designed and used (Figure 9). This allowed us to amplify the full-length *msg*-gene that presumably is the one being expressed. We chose two specimens for this analysis, that we thought would be interesting, based on the N120 screening. Both specimens were single infections according to the ITS typing. Firstly we chose the specimen that only expressed one N120 type sequence. When we screened the inserts generated from the full-length amplification and cloning, unexpectedly several clones contained another sequence than the previous N120-sequence. Surprisingly, this sequence was another N120a sequence. We thought that this sequence was of highly interest and decided to sequence this one. The second specimen chosen had two different N120-sequences and one of them was successfully amplified, cloned and fully sequenced. Pairwise comparisons of these two full-length *msg*-sequences showed 44% identity and 66% similarity for the amino acids, as well as a nucleotide identity of 61%. We also compared these sequences with the full-length silent *msg*-sequences described by Kutty *et al.* (104). These 24 sequences fall into two groups "A" and "B" in the phylogenetic analysis (104) and our two sequences fall into one group each. We also split the sequences into segments of approximately 330 amino acids and made three independent trees. These trees showed that recombination probably had taken place between different *msg*-genes, and one potential crossover is shown in Paper IV, Figure 5. This recombination may not represent recent events but could have occurred between similar segments of different genes at any time. We finally divided the *msg*-genes into different short regions, a conserved, a variable and a semi-variable, and investigated the variability influenced by different selective pressures. The pairwise nucleotide and protein identities showed that different regions are subjected to various selective pressures. There are both highly conserved protein regions, where the protein identity is higher than the nucleotide identity, and other regions with very low protein identities and even higher diversity at the nucleotide level.

### 4.3.3 Summary

In total, 113 partial expressed *msg*-genes were identified, among these 50 unique "type sequences" and 66 singletons. Most of the clinical single infected specimen showed several expressed N120-sequences at the same time. Some sequences occurred more frequently and some sequences were also closely related to sequences from another study conducted in another country. The average pairwise nucleotide identity was 69%, protein identity 53% and similarity 71%. Sequences generated from one specimen were not closer related than all the sequences in general. The overall variation was higher at

the protein level than the nucleotide level, indicating that there is a selective pressure to generate new variants of the MSG-protein. We also saw some traces of recombination between *msg*-gens, that can have occurred in the past, and recombination within the N120-segment, which should be further investigated.

In conclusion, there is a considerable variation in the expressed *msg*-genes, which is consistent with the hypothesis that one of the functions of the *msg*-gene family is immune evasion, but at the same time there is a substantial amount of conservation.

## 5 CONCLUSIONS

To investigate the atypical fungus *Pneumocystis*, causing PCP in humans, different loci of the *P. jirovecii* genome were analyzed. The targeted loci were ITS, DHPS and MSG and they were separately used to address different aspects of *P. jirovecii* infections leading to the following conclusions;

- The complexity of *P. jirovecii* populations has been overestimated.
- Typing fidelity can be improved by straightforward measures.
- The numbers of ITS haplotypes in Sweden are restricted.
- A model depicting the relationships between strains is proposed.
- *P. jirovecii* DHPS mutations are very rare or absent in Sweden.
- The *msg*-gene family displays a remarkable variation and conservation at the same time.

## 6 ACKNOWLEDGMENTS

*This work and thesis would not in a million have been finished without the help of two great men:*

The one and only **Per Hagblom**, supervisor, mentor, collaborator and friend. Thank thank thank you for all the help, discussions and time you spent, as well as fights over the years :) Especially a big thank for not hesitating a minute when I asked you for help to finish this. You are just the best! I have to figure out a way how we can continue to meet at Broströms during working hours.

**Johan Lindh**, my dear main supervisor, starting up as head of department, mentor, friend and finishing up as well as supervisor. Thank you for always keeping an eye on me and stepping up when I needed! Thank you for the care, help, support and nice attitude. I am very grateful! And I can't wait for my limerick.

*I am also grateful to some additional persons that have been important for this work:*

**Victor Fernandez**, thank you for bringing me in to the world of science and in particular mycology, teaching me a lot of laboratory skills and scientific thinking. Thank you for all interesting discussions regarding *Pneumocystis* as well as everything else. And for always believing in me! I am sorry we could not finish this together but I hope that our ways will be crossed again one day.

Co-supervisor **Silvia Botero-Kleiven**, thank you for the help and support over the years! Co-supervisor **Dr Chen**, thank you. **Leigh Dini** my *Pneumocystis* sister, thank you for collaboration and great friendship. **Marianne Lebbad** the parasite queen, thank you for all discussions regarding typing as well as other things and the support during the process of finishing this thesis. **Nicolas Joannin** thanks and see you in Japan. **Arnaud Chêne**, thank you for input on the immune part. Miss these two Frenchmen a lot. Collaborator **Margareta Krabbe**, **Jessica Weidner**, thanks for the English input and **Charli Eriksson** for input on the thesis.

Everyone that have been part of the great past **Mycology** group: Marlene, you are just a wonderful person and an open-minded and very skilled BMA, SMI is a bit poorer since you left, Erja, Stina, Eva, Frii, Ilke, Helin, and Srisuda, miss you my PhD student fellow, these years became different than we both though when we started, I think, with life you never know, but we do know that now it is your turn, good luck with your work! And I come and see you in Thailand one day.

All the parasite people at SMI, past and present: Aija, thank you for all the help and interest over the years, Kaitlin (puman), Lisbeth, Sylvia, Anna, Mia, Therese, Kristina, Antonio, Jadwiga, Romanico, Jonas, Isabel, Polya, Susanne, Daniel, Irene, Ewert and sweet Cecilia, thank you as well for all the coordinator things.

Malaria people at MTC, past and present: Sandra, Karin, Kirsten, Letusa, Karolina, Hodan, Fingani, Uffe, Kim, Niloo, Malin, Fredrik, Sanjay, Johan, Anna and Mats. Who else? You are so many = I have been around for too long.

My roommates: Lina, Fernando, Susanne and Noemia, it has been a pleasure. Good luck to you all with your work!

SMI: Rigmor and Benjamin, thank you for your comprehension and support. Tara, Mattias, Sven, Reza, Öjar and Mohamad. Marcelo, Tomas and Ramon, the sun always starts shining when you guys enter the corridor. Elizabeth, thank you for all the help with paperwork.

MTC: Anita Wallentin, Anna Lödgborg and Marie Arsenian Henriksson.

Dear friends from SMI: Maj, I am glad we are neighbors too, Lena Gz, Maria, Marie, Jolle, Anders Dansken, Johan, Arnaud, Nico and Elsie. And all the water people: Sabina, Emma, Elisabeth, Caroline, thanks being my mentor :), Annelie, Anette, Jonas, Jonas, Linda, Görel, Nga, Thor Axel, Therese, Mick and Jacob, I miss the old fika room.

Sorry everyone that I forgot, but thank you.

My family: my brother Michel and sisters Muriel and Nathalie with their families and my parents **Henri & Aniella**, thank you for the love, help and support, especially with little princess Isabella.

Ola and Isabella, the best family ever. I love you.

**This work was supported by the Swedish Institute for Communicable Disease Control, the Swedish International Development Cooperation Agency, the Swedish-South African Health Forum and the Karolinska Institutet.**

## 7 REFERENCES

1. **Aderaye, G., J. Bruchfeld, G. Aseffa, Y. Nigussie, K. Melaku, Y. Woldeamanuel, D. Asrat, A. Worku, H. Gaegziabher, M. Lebaad, and L. Lindquist.** 2007. Pneumocystis jiroveci pneumonia and other pulmonary infections in TB smear-negative HIV-positive patients with atypical chest X-ray in Ethiopia. *Scand J Infect Dis* **39**:1045-53.
2. **Aliouat-Denis, C. M., A. Martinez, M. Aliouat el, M. Pottier, N. Gantois, and E. Dei-Cas.** 2009. The Pneumocystis life cycle. *Mem Inst Oswaldo Cruz* **104**:419-26.
3. **Allred, D. R., J. M. Carlton, R. L. Satcher, J. A. Long, W. C. Brown, P. E. Patterson, R. M. O'Connor, and S. E. Stroup.** 2000. The ves multigene family of *B. bovis* encodes components of rapid antigenic variation at the infected erythrocyte surface. *Mol Cell* **5**:153-62.
4. **Alvarez-Martinez, M. J., J. M. Miro, M. E. Valls, J. Mas, J. P. de la Bellacasa, O. Sued, M. Sole, P. V. Rivas, E. de Lazzari, N. Benito, F. Garcia, C. Agusti, P. E. Wilson, J. M. Gatell, M. T. Jimenez de Anta, S. R. Meshnick, and A. Moreno.** 2010. Prevalence of dihydropteroate synthase genotypes before and after the introduction of combined antiretroviral therapy and their influence on the outcome of Pneumocystis pneumonia in HIV-1-infected patients. *Diagn Microbiol Infect Dis* **68**:60-5.
5. **Alvarez-Martinez, M. J., A. Moreno, J. M. Miro, M. E. Valls, P. V. Rivas, E. de Lazzari, O. Sued, N. Benito, P. Domingo, E. Ribera, M. Santin, G. Sirera, F. Segura, F. Vidal, F. Rodriguez, M. Riera, M. E. Cordero, J. R. Arribas, M. T. Jimenez de Anta, J. M. Gatell, P. E. Wilson, and S. R. Meshnick.** 2008. Pneumocystis jirovecii pneumonia in Spanish HIV-infected patients in the combined antiretroviral therapy era: prevalence of dihydropteroate synthase mutations and prognostic factors of mortality. *Diagn Microbiol Infect Dis* **62**:34-43.
6. **Ammich, O.** 1938. Uber die nichtsyphilitische interstitielle pneumoniae des ersten kindersalters. *Virchows Arch Pathol Anat* **302**:539-54.
7. **Arichi, N., H. Kishikawa, Y. Mitsui, T. Kato, K. Nishimura, R. Tachikawa, K. Tomii, H. Shiina, M. Igawa, and Y. Ichikawa.** 2009. Cluster outbreak of Pneumocystis pneumonia among kidney transplant patients within a single center. *Transplant Proc* **41**:170-2.
8. **Armengol, C. E.** 1995. A historical review of Pneumocystis carinii. *JAMA* **273**:747, 750-1.
9. **Azoulay, E., A. Parrot, A. Flahault, D. Cesari, I. Lecomte, P. Roux, F. Saidi, M. Fartoukh, J. F. Bernaudin, J. Cadranet, and C. Mayaud.** 1999. AIDS-related Pneumocystis carinii pneumonia in the era of adjunctive steroids: implication of BAL neutrophilia. *Am J Respir Crit Care Med* **160**:493-9.
10. **Barbour, A. G., N. Burman, C. J. Carter, T. Kitten, and S. Bergstrom.** 1991. Variable antigen genes of the relapsing fever agent *Borrelia hermsii* are activated by promoter addition. *Mol Microbiol* **5**:489-93.
11. **Barry, S. M., and M. A. Johnson.** 2001. Pneumocystis carinii pneumonia: a review of current issues in diagnosis and management. *HIV Med* **2**:123-32.
12. **Baruch, D. I., B. L. Pasloske, H. B. Singh, X. Bi, X. C. Ma, M. Feldman, T. F. Taraschi, and R. J. Howard.** 1995. Cloning the *P. falciparum* gene



- encoding PfEMP1, a malarial variant antigen and adherence receptor on the surface of parasitized human erythrocytes. *Cell* **82**:77-87.
13. **Beard, C. B., J. L. Carter, S. P. Keely, L. Huang, N. J. Pieniazek, I. N. Moura, J. M. Roberts, A. W. Hightower, M. S. Bens, A. R. Freeman, S. Lee, J. R. Stringer, J. S. Duchin, C. del Rio, D. Rimland, R. P. Baughman, D. A. Levy, V. J. Dietz, P. Simon, and T. R. Navin.** 2000. Genetic variation in *Pneumocystis carinii* isolates from different geographic regions: implications for transmission. *Emerg Infect Dis* **6**:265-72.
  14. **Beck, J. M., R. L. Newbury, B. E. Palmer, M. L. Warnock, P. K. Byrd, and H. B. Kaltreider.** 1996. Role of CD8+ lymphocytes in host defense against *Pneumocystis carinii* in mice. *J Lab Clin Med* **128**:477-87.
  15. **Beck, J. M., A. M. Preston, J. G. Wagner, S. E. Wilcoxon, P. Hossler, S. R. Meshnick, and R. Paine, 3rd.** 1998. Interaction of rat *Pneumocystis carinii* and rat alveolar epithelial cells in vitro. *Am J Physiol* **275**:L118-25.
  16. **Beck, J. M., M. L. Warnock, J. L. Curtis, M. J. Sniezek, S. M. Arraj-Peffer, H. B. Kaltreider, and J. E. Shellito.** 1991. Inflammatory responses to *Pneumocystis carinii* in mice selectively depleted of helper T lymphocytes. *Am J Respir Cell Mol Biol* **5**:186-97.
  17. **Beck, J. M., M. L. Warnock, H. B. Kaltreider, and J. E. Shellito.** 1993. Host defenses against *Pneumocystis carinii* in mice selectively depleted of CD4+ lymphocytes. *Chest* **103**:116S-118S.
  18. **Benecke, E.** 1938. Eigenartige Bronchiolenerkrankung im ersten Lebensjahr. *Verh Dtsch Ges Pathol* **31**:402-406.
  19. **Benfield, T. L., J. Vestbo, J. Junge, T. L. Nielsen, A. B. Jensen, and J. D. Lundgren.** 1995. Prognostic value of interleukin-8 in AIDS-associated *Pneumocystis carinii* pneumonia. *Am J Respir Crit Care Med* **151**:1058-62.
  20. **Bhagwat, S. P., F. Gigliotti, H. Xu, and T. W. Wright.** 2006. Contribution of T cell subsets to the pathophysiology of *Pneumocystis*-related immunorestitution disease. *Am J Physiol Lung Cell Mol Physiol* **291**:L1256-66.
  21. **Bonnet, F., C. Lewden, T. May, L. Heripret, E. Jouglu, S. Bevilacqua, D. Costagliola, D. Salmon, G. Chene, and P. Morlat.** 2005. Opportunistic infections as causes of death in HIV-infected patients in the HAART era in France. *Scand J Infect Dis* **37**:482-7.
  22. **Branten, A. J., P. J. Beckers, R. G. Tiggeler, and A. J. Hoitsma.** 1995. *Pneumocystis carinii* pneumonia in renal transplant recipients. *Nephrol Dial Transplant* **10**:1194-7.
  23. **Brooks, J. T., J. E. Kaplan, K. K. Holmes, C. Benson, A. Pau, and H. Masur.** 2009. HIV-associated opportunistic infections--going, going, but not gone: the continued need for prevention and treatment guidelines. *Clin Infect Dis* **48**:609-11.
  24. **Buchacz, K., R. K. Baker, A. C. Moorman, J. T. Richardson, K. C. Wood, S. D. Holmberg, and J. T. Brooks.** 2008. Rates of hospitalizations and associated diagnoses in a large multisite cohort of HIV patients in the United States, 1994-2005. *AIDS* **22**:1345-54.
  25. **Calderon-Sandubete, E. J., J. M. Varela-Aguilar, F. J. Medrano-Ortega, V. Nieto-Guerrer, N. Respaldiza-Salas, C. de la Horra-Padilla, and E. Deicas.** 2002. Historical perspective on *Pneumocystis carinii* infection. *Protist* **153**:303-10.
  26. **Calderon, E. J., L. Rivero, N. Respaldiza, R. Morilla, M. A. Montes-Cano, V. Friaza, F. Munoz-Lobato, J. M. Varela, F. J. Medrano, and L. Horra Cde.** 2007. Systemic inflammation in patients with chronic obstructive

- pulmonary disease who are colonized with *Pneumocystis jiroveci*. *Clin Infect Dis* **45**:e17-9.
27. **Campanella, J. J., L. Bitincka, and J. Smalley.** 2003. MatGAT: an application that generates similarity/identity matrices using protein or DNA sequences. *BMC Bioinformatics* **4**:29.
  28. **Carini, A.** 1910. Formas de eschizogonia do *Trypanosoma lewisi*. *Bol Soc de Med e Cir de Sao Paulo* **18**:204.
  29. **Catherinot, E., F. Lanternier, M. E. Bougnoux, M. Lecuit, L. J. Couderc, and O. Lortholary.** 2010. *Pneumocystis jirovecii* Pneumonia. *Infect Dis Clin North Am* **24**:107-38.
  30. **CDC.** [homepage on the internet]. Center for Disease Control and Prevention [updated 2009 July; cited 2011 June 03]. Available from: <http://www.dpd.cdc.gov/dpdx/HTML/Pneumocystis.htm>.
  31. **CDC, C. f. D. C.** 1981. Kaposi's sarcoma and *Pneumocystis pneumonia* among homosexual men--New York City and California. *MMWR Morb Mortal Wkly Rep* **30**:305-8.
  32. **CDC, C. f. D. C.** 1981. *Pneumocystis pneumonia*--Los Angeles. *MMWR Morb Mortal Wkly Rep* **30**:250-2.
  33. **Chabe, M., C. M. Aliouat-Denis, L. Delhaes, M. Aliouat el, E. Viscogliosi, and E. Dei-Cas.** 2011. *Pneumocystis*: from a doubtful unique entity to a group of highly diversified fungal species. *FEMS Yeast Res* **11**:2-17.
  34. **Chabe, M., E. Dei-Cas, C. Creusy, L. Fleurisse, N. Respaldiza, D. Camus, and I. Durand-Joly.** 2004. Immunocompetent hosts as a reservoir of *pneumocystis* organisms: histological and rt-PCR data demonstrate active replication. *Eur J Clin Microbiol Infect Dis* **23**:89-97.
  35. **Chagas, C.** 1911. Nova entidade morbida do homem: regumo general de estudos etiologicos e clinicos. *Mem Inst Oswaldo Cruz* **3**:219-275.
  36. **Chagas, C.** 1909. Nova tripanozomiazaea humana. *Mem Inst Oswaldo Cruz* **1**:159-218.
  37. **Chakaya, J. M., C. Bii, L. Ng'ang'a, E. Amukoye, T. Ouko, L. Muita, S. Gathua, J. Gitau, I. Odongo, J. M. Kabanga, K. Nagai, S. Suzumura, and Y. Sugiura.** 2003. *Pneumocystis carinii* pneumonia in HIV/AIDS patients at an urban district hospital in Kenya. *East Afr Med J* **80**:30-5.
  38. **Chave, J. P., S. David, J. P. Wauters, G. Van Melle, and P. Francioli.** 1991. Transmission of *Pneumocystis carinii* from AIDS patients to other immunosuppressed patients: a cluster of *Pneumocystis carinii* pneumonia in renal transplant recipients. *AIDS* **5**:927-32.
  39. **Chen, W., F. Gigliotti, and A. G. Harmsen.** 1993. Latency is not an inevitable outcome of infection with *Pneumocystis carinii*. *Infect Immun* **61**:5406-9.
  40. **Chen, W., E. A. Havell, and A. G. Harmsen.** 1992. Importance of endogenous tumor necrosis factor alpha and gamma interferon in host resistance against *Pneumocystis carinii* infection. *Infect Immun* **60**:1279-84.
  41. **Clement, M., D. Posada, and K. A. Crandall.** 2000. TCS: a computer program to estimate gene genealogies. *Mol Ecol* **9**:1657-9.
  42. **Cohen, O. J., and M. Y. Stoeckle.** 1991. Extrapulmonary *Pneumocystis carinii* infections in the acquired immunodeficiency syndrome. *Arch Intern Med* **151**:1205-14.
  43. **Costa, M. C., J. Helweg-Larsen, B. Lundgren, F. Antunes, and O. Matos.** 2003. Mutations in the dihydropteroate synthase gene of *Pneumocystis jiroveci* isolates from Portuguese patients with *Pneumocystis pneumonia*. *Int J Antimicrob Agents* **22**:516-20.

44. **Crothers, K., C. B. Beard, J. Turner, G. Groner, M. Fox, A. Morris, S. Eiser, and L. Huang.** 2005. Severity and outcome of HIV-associated *Pneumocystis pneumonia* containing *Pneumocystis jirovecii* dihydropteroate synthase gene mutations. *AIDS* **19**:801-5.
45. **Curtis, J. R., P. R. Yarnold, D. N. Schwartz, R. A. Weinstein, and C. L. Bennett.** 2000. Improvements in outcomes of acute respiratory failure for patients with human immunodeficiency virus-related *Pneumocystis carinii* pneumonia. *Am J Respir Crit Care Med* **162**:393-8.
46. **Cushion, M. T., and J. Arnold.** 1997. Proposal for a *Pneumocystis* genome project. *J Eukaryot Microbiol* **44**:7S.
47. **Cushion, M. T., S. P. Keely, and J. R. Stringer.** 2004. Molecular and phenotypic description of *Pneumocystis wakefieldiae* sp. nov., a new species in rats. *Mycologia* **96**:429-38.
48. **Cushion, M. T., and A. G. Smulian.** 2001. The pneumocystis genome project: update and issues. *J Eukaryot Microbiol Suppl*:182S-183S.
49. **Cushion, M. T., A. G. Smulian, B. E. Slaven, T. Sesterhenn, J. Arnold, C. Staben, A. Porollo, R. Adamczak, and J. Meller.** 2007. Transcriptome of *Pneumocystis carinii* during fulminate infection: carbohydrate metabolism and the concept of a compatible parasite. *PLoS One* **2**:e423.
50. **Dallas, W. S., J. E. Gowen, P. H. Ray, M. J. Cox, and I. K. Dev.** 1992. Cloning, sequencing, and enhanced expression of the dihydropteroate synthase gene of *Escherichia coli* MC4100. *J Bacteriol* **174**:5961-70.
51. **de Boer, M. G., L. E. Bruijnesteijn van Coppenraet, A. Gaasbeek, S. P. Berger, L. B. Gelinck, H. C. van Houwelingen, P. van den Broek, E. J. Kuijper, F. P. Kroon, and J. P. Vandenbroucke.** 2007. An outbreak of *Pneumocystis jirovecii* pneumonia with 1 predominant genotype among renal transplant recipients: interhuman transmission or a common environmental source? *Clin Infect Dis* **44**:1143-9.
52. **Dei-Cas, E., M. Chabe, R. Moukhlis, I. Durand-Joly, M. Aliouat el, J. R. Stringer, M. Cushion, C. Noel, G. S. de Hoog, J. Guillot, and E. Viscogliosi.** 2006. *Pneumocystis oryctolagi* sp. nov., an uncultured fungus causing pneumonia in rabbits at weaning: review of current knowledge, and description of a new taxon on genotypic, phylogenetic and phenotypic bases. *FEMS Microbiol Rev* **30**:853-71.
53. **Deitsch, K. W., S. A. Lukehart, and J. R. Stringer.** 2009. Common strategies for antigenic variation by bacterial, fungal and protozoan pathogens. *Nat Rev Microbiol* **7**:493-503.
54. **Delanoë, P., and M. Delanoë.** 1912. Sur les rapports des kystes de *carinii* du poumon des rats avec le *Trypanosoma lewisi*. *CR Acad Sci (Paris)* **155**.
55. **Dini, L., M. du Plessis, J. Frean, and V. Fernandez.** 2010. High prevalence of dihydropteroate synthase mutations in *Pneumocystis jirovecii* isolated from patients with *Pneumocystis pneumonia* in South Africa. *J Clin Microbiol* **48**:2016-21.
56. **Edman, J. C., T. W. Hatton, M. Nam, R. Turner, Q. Mei, C. W. Angus, and J. A. Kovacs.** 1996. A single expression site with a conserved leader sequence regulates variation of expression of the *Pneumocystis carinii* family of major surface glycoprotein genes. *DNA Cell Biol* **15**:989-99.
57. **Edman, J. C., J. A. Kovacs, H. Masur, D. V. Santi, H. J. Elwood, and M. L. Sogin.** 1988. Ribosomal RNA sequence shows *Pneumocystis carinii* to be a member of the fungi. *Nature* **334**:519-22.

58. **Elvin, K. M., A. Bjorkman, E. Linder, N. Heurlin, and A. Hjerpe.** 1988. Pneumocystis carinii pneumonia: detection of parasites in sputum and bronchoalveolar lavage fluid by monoclonal antibodies. *BMJ* **297**:381-4.
59. **Esteves, F., J. Gaspar, A. Tavares, I. Moser, F. Antunes, K. Mansinho, and O. Matos.** 2010. Population structure of Pneumocystis jirovecii isolated from immunodeficiency virus-positive patients. *Infect Genet Evol* **10**:192-9.
60. **Esteves, F., M. A. Montes-Cano, C. de la Horra, M. C. Costa, E. J. Calderon, F. Antunes, and O. Matos.** 2008. Pneumocystis jirovecii multilocus genotyping profiles in patients from Portugal and Spain. *Clin Microbiol Infect* **14**:356-62.
61. **Filler, S. G.** 2006. Candida-host cell receptor-ligand interactions. *Curr Opin Microbiol* **9**:333-9.
62. **Frenkel, J. K.** 1976. Pneumocystis jirovecii n. sp. from man: morphology, physiology, and immunology in relation to pathology. *Natl Cancer Inst Monogr* **43**:13-30.
63. **Frenkel, J. K.** 1999. Pneumocystis pneumonia, an immunodeficiency-dependent disease (IDD): a critical historical overview. *J Eukaryot Microbiol* **46**:89S-92S.
64. **Friaza, V., R. Morilla, N. Respaldiza, C. de la Horra, and E. J. Calderon.** 2010. Pneumocystis jirovecii dihydropteroate synthase gene mutations among colonized individuals and Pneumocystis pneumonia patients from Spain. *Postgrad Med* **122**:24-8.
65. **Gajdusek, D. C.** 1957. Pneumocystis carinii; etiologic agent of interstitial plasma cell pneumonia of premature and young infants. *Pediatrics* **19**:543-65.
66. **Garbe, T. R., and J. R. Stringer.** 1994. Molecular characterization of clustered variants of genes encoding major surface antigens of human Pneumocystis carinii. *Infect Immun* **62**:3092-101.
67. **Gigliotti, F., A. G. Harmsen, C. G. Haidaris, and P. J. Haidaris.** 1993. Pneumocystis carinii is not universally transmissible between mammalian species. *Infect Immun* **61**:2886-90.
68. **Goldman, A. S., L. R. Goldman, and D. A. Goldman.** 2005. What caused the epidemic of Pneumocystis pneumonia in European premature infants in the mid-20th century? *Pediatrics* **115**:e725-36.
69. **Gottlieb, M. S., R. Schroff, H. M. Schanker, J. D. Weisman, P. T. Fan, R. A. Wolf, and A. Saxon.** 1981. Pneumocystis carinii pneumonia and mucosal candidiasis in previously healthy homosexual men: evidence of a new acquired cellular immunodeficiency. *N Engl J Med* **305**:1425-31.
70. **Gupta, R., B. R. Mirdha, R. Guleria, S. K. Agarwal, J. C. Samantaray, L. Kumar, S. K. Kabra, K. Luthra, and V. Sreenivas.** 2010. Genotyping and phylogenetic analysis of Pneumocystis jirovecii isolates from India. *Infect Genet Evol*.
71. **Haidaris, C. G., O. F. Medzihradsky, F. Gigliotti, and P. J. Simpson-Haidaris.** 1998. Molecular characterization of mouse Pneumocystis carinii surface glycoprotein A. *DNA Res* **5**:77-85.
72. **Hampele, I. C., A. D'Arcy, G. E. Dale, D. Kostrewa, J. Nielsen, C. Oefner, M. G. Page, H. J. Schonfeld, D. Stuber, and R. L. Then.** 1997. Structure and function of the dihydropteroate synthase from Staphylococcus aureus. *J Mol Biol* **268**:21-30.
73. **Harmsen, A. G., and M. Stankiewicz.** 1990. Requirement for CD4+ cells in resistance to Pneumocystis carinii pneumonia in mice. *J Exp Med* **172**:937-45.
74. **Helweg-Larsen, J., T. L. Benfield, J. Eugen-Olsen, J. D. Lundgren, and B. Lundgren.** 1999. Effects of mutations in Pneumocystis carinii dihydropteroate

- synthase gene on outcome of AIDS-associated *P. carinii* pneumonia. *Lancet* **354**:1347-51.
75. **Helweg-Larsen, J., C. H. Lee, S. Jin, J. Y. Hsueh, T. L. Benfield, J. Hansen, J. D. Lundgren, and B. Lundgren.** 2001. Clinical correlation of variations in the internal transcribed spacer regions of rRNA genes in *Pneumocystis carinii* f.sp. hominis. *AIDS* **15**:451-9.
  76. **Hennequin, C., B. Page, P. Roux, C. Legendre, and H. Kreis.** 1995. Outbreak of *Pneumocystis carinii* pneumonia in a renal transplant unit. *Eur J Clin Microbiol Infect Dis* **14**:122-6.
  77. **Hocker, B., C. Wendt, A. Nahimana, B. Tonshoff, and P. M. Hauser.** 2005. Molecular evidence of *Pneumocystis* transmission in pediatric transplant unit. *Emerg Infect Dis* **11**:330-2.
  78. **Hoffman, O. A., J. E. Standing, and A. H. Limper.** 1993. *Pneumocystis carinii* stimulates tumor necrosis factor-alpha release from alveolar macrophages through a beta-glucan-mediated mechanism. *J Immunol* **150**:3932-40.
  79. **Hosoya, N., T. Takahashi, M. Wada, T. Endo, T. Nakamura, H. Sakashita, K. Kimura, K. Ohnishi, Y. Nakamura, T. Mizuochi, and A. Iwamoto.** 2000. Genotyping of *Pneumocystis carinii* f. sp. hominis isolates in Japan based on nucleotide sequence variations in internal transcribed spacer regions of rRNA genes. *Microbiol Immunol* **44**:591-6.
  80. **Huang, L., C. B. Beard, J. Creasman, D. Levy, J. S. Duchin, S. Lee, N. Pieniazek, J. L. Carter, C. del Rio, D. Rimland, and T. R. Navin.** 2000. Sulfa or sulfone prophylaxis and geographic region predict mutations in the *Pneumocystis carinii* dihydropteroate synthase gene. *J Infect Dis* **182**:1192-8.
  81. **Huang, L., K. Crothers, A. Morris, G. Groner, M. Fox, J. R. Turner, C. Merrifield, S. Eiser, P. Zuchi, and C. B. Beard.** 2003. *Pneumocystis* colonization in HIV-infected patients. *J Eukaryot Microbiol* **50 Suppl**:616-7.
  82. **Huang, L., A. Morris, A. H. Limper, and J. M. Beck.** 2006. An Official ATS Workshop Summary: Recent advances and future directions in pneumocystis pneumonia (PCP). *Proc Am Thorac Soc* **3**:655-64.
  83. **Huang, L., D. A. Welsh, R. F. Miller, C. B. Beard, G. G. Lawrence, M. Fox, A. Swartzman, M. R. Bensley, D. Carbonnet, J. L. Davis, A. Chi, B. J. Yoo, and J. L. Jones.** 2006. *Pneumocystis jirovecii* dihydropteroate synthase gene mutations and human immunodeficiency virus-associated *Pneumocystis* pneumonia. *J Eukaryot Microbiol* **53 Suppl 1**:S114-6.
  84. **Hughes, W. T.** 1978. *Pneumocystis* pneumonia: a plague of the immunosuppressed. *Johns Hopkins Med J* **143**:184-92.
  85. **Hughes, W. T., S. Feldman, and S. K. Sanyal.** 1975. Treatment of *Pneumocystis carinii* pneumonitis with trimethoprim-sulfamethoxazole. *Can Med Assoc J* **112**:47-50.
  86. **Iliades, P., S. R. Meshnick, and I. G. Macreadie.** 2005. Mutations in the *Pneumocystis jirovecii* DHPS gene confer cross-resistance to sulfa drugs. *Antimicrob Agents Chemother* **49**:741-8.
  87. **Ivady, G., and L. Paldy.** 1958. Ein neues Behandlungsverfahren der interstitiellen plasmazelligen Pneumonie Frühgeborener mit fünfwertigem Stibium und aromatischen Diamiden. *M Schr Kinderheilk* **106**:10-14.
  88. **Kai, M., M. Matsuoka, N. Nakata, S. Maeda, M. Gidoh, Y. Maeda, K. Hashimoto, K. Kobayashi, and Y. Kashiwabara.** 1999. Diaminodiphenylsulfone resistance of *Mycobacterium leprae* due to mutations in the dihydropteroate synthase gene. *FEMS Microbiol Lett* **177**:231-5.

89. **Kaneshiro, E. S.** 1998. The lipids of *Pneumocystis carinii*. *Clin Microbiol Rev* **11**:27-41.
90. **Katoh, K., and H. Toh.** 2008. Recent developments in the MAFFT multiple sequence alignment program. *Brief Bioinform* **9**:286-98.
91. **Kazanjian, P., W. Armstrong, P. A. Hossler, W. Burman, J. Richardson, C. H. Lee, L. Crane, J. Katz, and S. R. Meshnick.** 2000. *Pneumocystis carinii* mutations are associated with duration of sulfa or sulfone prophylaxis exposure in AIDS patients. *J Infect Dis* **182**:551-7.
92. **Kazanjian, P. H., D. Fisk, W. Armstrong, Q. Shulin, H. Liwei, Z. Ke, and S. Meshnick.** 2004. Increase in prevalence of *Pneumocystis carinii* mutations in patients with AIDS and *P. carinii* pneumonia, in the United States and China. *J Infect Dis* **189**:1684-7.
93. **Keely, S. P., J. M. Fischer, M. T. Cushion, and J. R. Stringer.** 2004. Phylogenetic identification of *Pneumocystis murina* sp. nov., a new species in laboratory mice. *Microbiology* **150**:1153-65.
94. **Keely, S. P., H. Renauld, A. E. Wakefield, M. T. Cushion, A. G. Smulian, N. Fosker, A. Fraser, D. Harris, L. Murphy, C. Price, M. A. Quail, K. Seeger, S. Sharp, C. J. Tindal, T. Warren, E. Zuiderwijk, B. G. Barrell, J. R. Stringer, and N. Hall.** 2005. Gene arrays at *Pneumocystis carinii* telomeres. *Genetics* **170**:1589-600.
95. **Kitada, K., M. Wada, and Y. Nakamura.** 1994. Multi-gene family of major surface glycoproteins of *Pneumocystis carinii*: full-size cDNA cloning and expression. *DNA Res* **1**:57-66.
96. **Kolls, J. K., D. Lei, C. Vazquez, G. Odom, W. R. Summer, S. Nelson, and J. Shellito.** 1997. Exacerbation of murine *Pneumocystis carinii* infection by adenoviral-mediated gene transfer of a TNF inhibitor. *Am J Respir Cell Mol Biol* **16**:112-8.
97. **Kottom, T. J., J. R. Kohler, C. F. Thomas, Jr., G. R. Fink, and A. H. Limper.** 2003. Lung epithelial cells and extracellular matrix components induce expression of *Pneumocystis carinii* STE20, a gene complementing the mating and pseudohyphal growth defects of STE20 mutant yeast. *Infect Immun* **71**:6463-71.
98. **Kovacs, J. A., V. J. Gill, S. Meshnick, and H. Masur.** 2001. New insights into transmission, diagnosis, and drug treatment of *Pneumocystis carinii* pneumonia. *JAMA* **286**:2450-60.
99. **Kovacs, J. A., J. W. Hiemenz, A. M. Macher, D. Stover, H. W. Murray, J. Shelhamer, H. C. Lane, C. Urmacher, C. Honig, D. L. Longo, and et al.** 1984. *Pneumocystis carinii* pneumonia: a comparison between patients with the acquired immunodeficiency syndrome and patients with other immunodeficiencies. *Ann Intern Med* **100**:663-71.
100. **Kovacs, J. A., F. Powell, J. C. Edman, B. Lundgren, A. Martinez, B. Drew, and C. W. Angus.** 1993. Multiple genes encode the major surface glycoprotein of *Pneumocystis carinii*. *J Biol Chem* **268**:6034-40.
101. **Koziel, H., Q. Eichbaum, B. A. Kruskal, P. Pinkston, R. A. Rogers, M. Y. Armstrong, F. F. Richards, R. M. Rose, and R. A. Ezekowitz.** 1998. Reduced binding and phagocytosis of *Pneumocystis carinii* by alveolar macrophages from persons infected with HIV-1 correlates with mannose receptor downregulation. *J Clin Invest* **102**:1332-44.
102. **Koziel, H., X. Li, M. Y. Armstrong, F. F. Richards, and R. M. Rose.** 2000. Alveolar macrophages from human immunodeficiency virus-infected persons demonstrate impaired oxidative burst response to *Pneumocystis carinii* in vitro. *Am J Respir Cell Mol Biol* **23**:452-9.

103. **Kutty, G., L. Ma, and J. A. Kovacs.** 2001. Characterization of the expression site of the major surface glycoprotein of human-derived *Pneumocystis carinii*. *Mol Microbiol* **42**:183-93.
104. **Kutty, G., F. Maldarelli, G. Achaz, and J. A. Kovacs.** 2008. Variation in the major surface glycoprotein genes in *Pneumocystis jirovecii*. *J Infect Dis* **198**:741-9.
105. **Larsen, H. H., M. L. von Linstow, B. Lundgren, B. Høgh, H. Westh, and J. D. Lundgren.** 2007. Primary pneumocystis infection in infants hospitalized with acute respiratory tract infection. *Emerg Infect Dis* **13**:66-72.
106. **Lasbury, M. E., P. J. Durant, C. A. Ray, D. Tschang, R. Schwendener, and C. H. Lee.** 2006. Suppression of alveolar macrophage apoptosis prolongs survival of rats and mice with pneumocystis pneumonia. *J Immunol* **176**:6443-53.
107. **Latouche, S., P. Lacube, E. Maury, J. Bolognini, M. Develoux, P. M. Girard, C. Godet, M. G. Lebrette, C. Mayaud, J. Guillot, and P. Roux.** 2003. *Pneumocystis jirovecii* dihydropteroate synthase genotypes in French patients with pneumocystosis: a 1998-2001 prospective study. *Med Mycol* **41**:533-7.
108. **Latouche, S., E. Ortona, E. Mazars, P. Margutti, E. Tamburrini, A. Siracusano, K. Guyot, M. Nigou, and P. Roux.** 1997. Biodiversity of *Pneumocystis carinii* hominis: typing with different DNA regions. *J Clin Microbiol* **35**:383-7.
109. **Lee, C. H., J. Helweg-Larsen, X. Tang, S. Jin, B. Li, M. S. Bartlett, J. J. Lu, B. Lundgren, J. D. Lundgren, M. Olsson, S. B. Lucas, P. Roux, A. Cargnel, C. Atzori, O. Matos, and J. W. Smith.** 1998. Update on *Pneumocystis carinii* f. sp. hominis typing based on nucleotide sequence variations in internal transcribed spacer regions of rRNA genes. *J Clin Microbiol* **36**:734-41.
110. **Limper, A. H., M. Edens, R. A. Anders, and E. B. Leof.** 1998. *Pneumocystis carinii* inhibits cyclin-dependent kinase activity in lung epithelial cells. *J Clin Invest* **101**:1148-55.
111. **Limper, A. H., J. S. Hoyte, and J. E. Standing.** 1997. The role of alveolar macrophages in *Pneumocystis carinii* degradation and clearance from the lung. *J Clin Invest* **99**:2110-7.
112. **Limper, A. H., and W. J. Martin, 2nd.** 1990. *Pneumocystis carinii*: inhibition of lung cell growth mediated by parasite attachment. *J Clin Invest* **85**:391-6.
113. **Limper, A. H., K. P. Offord, T. F. Smith, and W. J. Martin, 2nd.** 1989. *Pneumocystis carinii* pneumonia. Differences in lung parasite number and inflammation in patients with and without AIDS. *Am Rev Respir Dis* **140**:1204-9.
114. **Limper, A. H., J. E. Standing, O. A. Hoffman, M. Castro, and L. W. Neese.** 1993. Vitronectin binds to *Pneumocystis carinii* and mediates organism attachment to cultured lung epithelial cells. *Infect Immun* **61**:4302-9.
115. **Liu, Y., J. W. Leigh, H. Brinkmann, M. T. Cushion, N. Rodriguez-Ezpeleta, H. Philippe, and B. F. Lang.** 2009. Phylogenomic analyses support the monophyly of Taphrinomycotina, including *Schizosaccharomyces* fission yeasts. *Mol Biol Evol* **26**:27-34.
116. **Lu, J. J., M. S. Bartlett, M. M. Shaw, S. F. Queener, J. W. Smith, M. Ortiz-Rivera, M. J. Leibowitz, and C. H. Lee.** 1994. Typing of *Pneumocystis carinii* strains that infect humans based on nucleotide sequence variations of internal transcribed spacers of rRNA genes. *J Clin Microbiol* **32**:2904-12.
117. **Lund, F. E., M. Hollifield, K. Schuer, J. L. Lines, T. D. Randall, and B. A. Garvy.** 2006. B cells are required for generation of protective effector and

- memory CD4 cells in response to *Pneumocystis* lung infection. *J Immunol* **176**:6147-54.
118. **Läkemedelsverket.** [homepage on the internet]. Medical Products Agency [cited 2011 June 08]. Available from: <http://www.lakemedelsverket.se/malgrupp/Halso---sjukvard/Behandlings--rekommendationer/Behandlingsrekommendation---listan/Svampinfektioner/>.
  119. **Ma, L., L. Borio, H. Masur, and J. A. Kovacs.** 1999. *Pneumocystis carinii* dihydropteroate synthase but not dihydrofolate reductase gene mutations correlate with prior trimethoprim-sulfamethoxazole or dapsone use. *J Infect Dis* **180**:1969-78.
  120. **Ma, L., J. A. Kovacs, A. Cargnel, A. Valerio, G. Fantoni, and C. Atzori.** 2002. Mutations in the dihydropteroate synthase gene of human-derived *Pneumocystis carinii* isolates from Italy are infrequent but correlate with prior sulfa prophylaxis. *J Infect Dis* **185**:1530-2.
  121. **Mahomed, A. G., J. Murray, S. Klempman, G. Richards, C. Feldman, N. T. Levy, C. Smith, and J. Kallenbach.** 1999. *Pneumocystis carinii* pneumonia in HIV infected patients from South Africa. *East Afr Med J* **76**:80-4.
  122. **Malin, A. S., L. K. Gwanzura, S. Klein, V. J. Robertson, P. Musvaire, and P. R. Mason.** 1995. *Pneumocystis carinii* pneumonia in Zimbabwe. *Lancet* **346**:1258-61.
  123. **Maskell, N. A., D. J. Waine, A. Lindley, J. C. Pepperell, A. E. Wakefield, R. F. Miller, and R. J. Davies.** 2003. Asymptomatic carriage of *Pneumocystis jiroveci* in subjects undergoing bronchoscopy: a prospective study. *Thorax* **58**:594-7.
  124. **Masters, P. A., T. A. O'Bryan, J. Zurlo, D. Q. Miller, and N. Joshi.** 2003. Trimethoprim-sulfamethoxazole revisited. *Arch Intern Med* **163**:402-10.
  125. **Masur, H., M. A. Michelis, J. B. Greene, I. Onorato, R. A. Stouwe, R. S. Holzman, G. Wormser, L. Brettman, M. Lange, H. W. Murray, and S. Cunningham-Rundles.** 1981. An outbreak of community-acquired *Pneumocystis carinii* pneumonia: initial manifestation of cellular immune dysfunction. *N Engl J Med* **305**:1431-8.
  126. **Matos, O., C. H. Lee, S. Jin, B. Li, M. C. Costa, L. Goncalves, and F. Antunes.** 2003. *Pneumocystis jiroveci* in Portuguese immunocompromised patients: association of specific ITS genotypes with treatment failure, bad clinical outcome and childhood. *Infect Genet Evol* **3**:281-5.
  127. **Matsumoto, Y., and Y. Yoshida.** 1984. Sporogony in *Pneumocystis carinii*: synaptonemal complexes and meiotic nuclear divisions observed in precysts. *J Protozool* **31**:420-8.
  128. **Medrano, F. J., M. Montes-Cano, M. Conde, C. de la Horra, N. Respaldiza, A. Gasch, M. J. Perez-Lozano, J. M. Varela, and E. J. Calderon.** 2005. *Pneumocystis jirovecii* in general population. *Emerg Infect Dis* **11**:245-50.
  129. **Medrano, F. J., N. Respaldiza, A. Medrano, J. M. Varela, M. Montes-Cano, C. de la Horra, I. Wichmann, S. Ferrer, and E. Calderon.** 2003. Seroprevalence of *Pneumocystis* human infection in southern Spain. *J Eukaryot Microbiol* **50 Suppl**:649-50.
  130. **Meer, G. v. d., and S. Brug.** 1942. Infection par *Pneumocystis* chez l'homme et chez les animaux. *Annales de la Société Belge de Médecine Tropicale*:301-5.
  131. **Meneau, I., D. Sanglard, J. Bille, and P. M. Hauser.** 2004. *Pneumocystis jiroveci* dihydropteroate synthase polymorphisms confer resistance to sulfadoxine and sulfanilamide in *Saccharomyces cerevisiae*. *Antimicrob Agents Chemother* **48**:2610-6.



132. **Merz, A. J., and M. So.** 2000. Interactions of pathogenic neisseriae with epithelial cell membranes. *Annu Rev Cell Dev Biol* **16**:423-57.
133. **Meuwissen, J. H., I. Tauber, A. D. Leeuwenberg, P. J. Beckers, and M. Sieben.** 1977. Parasitologic and serologic observations of infection with *Pneumocystis* in humans. *J Infect Dis* **136**:43-9.
134. **Meyerhans, A., J. P. Vartanian, and S. Wain-Hobson.** 1990. DNA recombination during PCR. *Nucleic Acids Res* **18**:1687-91.
135. **Miguez-Burbano, M. J., D. Ashkin, A. Rodriguez, R. Duncan, A. Pitchenik, N. Quintero, M. Flores, and G. Shor-Posner.** 2005. Increased risk of *Pneumocystis carinii* and community-acquired pneumonia with tobacco use in HIV disease. *Int J Infect Dis* **9**:208-17.
136. **Miguez-Burbano, M. J., X. Burbano, D. Ashkin, A. Pitchenik, R. Allan, L. Pineda, N. Rodriguez, and G. Shor-Posner.** 2003. Impact of tobacco use on the development of opportunistic respiratory infections in HIV seropositive patients on antiretroviral therapy. *Addict Biol* **8**:39-43.
137. **Mikaelsson, L., G. Jacobsson, and R. Andersson.** 2006. *Pneumocystis pneumonia*--a retrospective study 1991-2001 in Gothenburg, Sweden. *J Infect* **53**:260-5.
138. **Miller, R. F., H. E. Ambrose, and A. E. Wakefield.** 2001. *Pneumocystis carinii* f. sp. hominis DNA in immunocompetent health care workers in contact with patients with *P. carinii* pneumonia. *J Clin Microbiol* **39**:3877-82.
139. **Miller, R. F., and A. E. Wakefield.** 1999. *Pneumocystis carinii* genotypes and severity of pneumonia. *Lancet* **353**:2039-40.
140. **Mocroft, A., P. Reiss, J. Gasiorowski, B. Ledergerber, J. Kowalska, A. Chiesi, J. Gatell, A. Rakhmanova, M. Johnson, O. Kirk, and J. Lundgren.** 2010. Serious fatal and nonfatal non-AIDS-defining illnesses in Europe. *J Acquir Immune Defic Syndr* **55**:262-70.
141. **Monnet, X., E. Vidal-Petiot, D. Osman, O. Hamzaoui, A. Durrbach, C. Goujard, C. Miceli, P. Bouree, and C. Richard.** 2008. Critical care management and outcome of severe *Pneumocystis pneumonia* in patients with and without HIV infection. *Crit Care* **12**:R28.
142. **Montes-Cano, M. A., M. Chabe, M. Fontillon-Alberdi, C. de-Lahorra, N. Respaldiza, F. J. Medrano, J. M. Varela, E. Dei-Cas, and E. J. Calderon.** 2009. Vertical transmission of *Pneumocystis jirovecii* in humans. *Emerg Infect Dis* **15**:125-7.
143. **Morris, A., L. A. Kingsley, G. Groner, I. P. Lebedeva, C. B. Beard, and K. A. Norris.** 2004. Prevalence and clinical predictors of *Pneumocystis* colonization among HIV-infected men. *AIDS* **18**:793-8.
144. **Morris, A., F. C. Sciurba, I. P. Lebedeva, A. Githaiga, W. M. Elliott, J. C. Hogg, L. Huang, and K. A. Norris.** 2004. Association of chronic obstructive pulmonary disease severity and *Pneumocystis* colonization. *Am J Respir Crit Care Med* **170**:408-13.
145. **Nahimana, A., M. Rabodonirina, G. Zanetti, I. Meneau, P. Francioli, J. Bille, and P. M. Hauser.** 2003. Association between a specific *Pneumocystis jirovecii* dihydropteroate synthase mutation and failure of pyrimethamine/sulfadoxine prophylaxis in human immunodeficiency virus-positive and -negative patients. *J Infect Dis* **188**:1017-23.
146. **Nash, T. E.** 2002. Surface antigenic variation in *Giardia lamblia*. *Mol Microbiol* **45**:585-90.
147. **Nevez, G., E. Magois, H. Duwat, V. Gouilleux, V. Jounieaux, and A. Totet.** 2006. Apparent absence of *Pneumocystis jirovecii* in healthy subjects. *Clin Infect Dis* **42**:e99-101.

148. **Nevez, G., C. Raccurt, P. Vincent, V. Jounieaux, and E. Dei-Cas.** 1999. Pulmonary colonization with *Pneumocystis carinii* in human immunodeficiency virus-negative patients: assessing risk with blood CD4+ T cell counts. *Clin Infect Dis* **29**:1331-2.
149. **Nevez, G., A. Totet, V. Jounieaux, J. L. Schmit, E. Dei-Cas, and C. Raccurt.** 2003. *Pneumocystis jiroveci* internal transcribed spacer types in patients colonized by the fungus and in patients with pneumocystosis from the same French geographic region. *J Clin Microbiol* **41**:181-6.
150. **Nimri, L. F., I. N. Moura, L. Huang, C. del Rio, D. Rimland, J. S. Duchin, E. M. Dotson, and C. B. Beard.** 2002. Genetic diversity of *Pneumocystis carinii* f. sp. *hominis* based on variations in nucleotide sequences of internal transcribed spacers of rRNA genes. *J Clin Microbiol* **40**:1146-51.
151. **O'Donnell, W. J., W. Pieciak, G. M. Chertow, J. Sanabria, and K. C. Lahive.** 1998. Clearance of *Pneumocystis carinii* cysts in acute *P. carinii* pneumonia: assessment by serial sputum induction. *Chest* **114**:1264-8.
152. **Peglow, S. L., A. G. Smulian, M. J. Linke, C. L. Pogue, S. Nurre, J. Crisler, J. Phair, J. W. Gold, D. Armstrong, and P. D. Walzer.** 1990. Serologic responses to *Pneumocystis carinii* antigens in health and disease. *J Infect Dis* **161**:296-306.
153. **Pifer, L. L., W. T. Hughes, S. Stagno, and D. Woods.** 1978. *Pneumocystis carinii* infection: evidence for high prevalence in normal and immunosuppressed children. *Pediatrics* **61**:35-41.
154. **Pixley, F. J., A. E. Wakefield, S. Banerji, and J. M. Hopkin.** 1991. Mitochondrial gene sequences show fungal homology for *Pneumocystis carinii*. *Mol Microbiol* **5**:1347-51.
155. **Probst, M., H. Ries, T. Schmidt-Wieland, and A. Serr.** 2000. Detection of *Pneumocystis carinii* DNA in patients with chronic lung diseases. *Eur J Clin Microbiol Infect Dis* **19**:644-5.
156. **Project, P. G.** [homepage on the internet]. *Pneumocystis Genome Project* [cited 2011 June 08]. Available from: <http://pgp.cchmc.org/>.
157. **Rabodonirina, M., D. Raffenot, L. Cotte, A. Boibieux, M. Mayencon, G. Bayle, F. Persat, F. Rabatel, C. Trepo, D. Peyramond, and M. A. Piens.** 1997. Rapid detection of *Pneumocystis carinii* in bronchoalveolar lavage specimens from human immunodeficiency virus-infected patients: use of a simple DNA extraction procedure and nested PCR. *J Clin Microbiol* **35**:2748-51.
158. **Rabodonirina, M., P. Vanhems, S. Couray-Targe, R. P. Gillibert, C. Ganne, N. Nizard, C. Colin, J. Fabry, J. L. Touraine, G. van Melle, A. Nahimana, P. Francioli, and P. M. Hauser.** 2004. Molecular evidence of interhuman transmission of *Pneumocystis pneumonia* among renal transplant recipients hospitalized with HIV-infected patients. *Emerg Infect Dis* **10**:1766-73.
159. **Robberts, F. J., L. D. Liebowitz, and L. J. Chalkley.** 2004. Genotyping and coalescent phylogenetic analysis of *Pneumocystis jiroveci* from South Africa. *J Clin Microbiol* **42**:1505-10.
160. **Roths, J. B., and C. L. Sidman.** 1992. Both immunity and hyperresponsiveness to *Pneumocystis carinii* result from transfer of CD4+ but not CD8+ T cells into severe combined immunodeficiency mice. *J Clin Invest* **90**:673-8.
161. **Russian, D. A., and S. J. Levine.** 2001. *Pneumocystis carinii* pneumonia in patients without HIV infection. *Am J Med Sci* **321**:56-65.

162. **Saiki, R. K., D. H. Gelfand, S. Stoffel, S. J. Scharf, R. Higuchi, G. T. Horn, K. B. Mullis, and H. A. Erlich.** 1988. Primer-directed enzymatic amplification of DNA with a thermostable DNA polymerase. *Science* **239**:487-91.
163. **Schmoldt, S., R. Schuegger, T. Wendler, I. Huber, H. Sollner, M. Hogardt, H. Arbogast, J. Heesemann, L. Bader, and A. Sing.** 2008. Molecular evidence of nosocomial *Pneumocystis jirovecii* transmission among 16 patients after kidney transplantation. *J Clin Microbiol* **46**:966-71.
164. **Sepkowitz, K. A.** 2002. Opportunistic infections in patients with and patients without Acquired Immunodeficiency Syndrome. *Clin Infect Dis* **34**:1098-107.
165. **Sepkowitz, K. A.** 1993. *Pneumocystis carinii* pneumonia in patients without AIDS. *Clin Infect Dis* **17 Suppl 2**:S416-22.
166. **Sepkowitz, K. A., A. E. Brown, and D. Armstrong.** 1995. *Pneumocystis carinii* pneumonia without acquired immunodeficiency syndrome. More patients, same risk. *Arch Intern Med* **155**:1125-8.
167. **Shannon, C.** 1948. A mathematical theory of communication. *Bell. Syst. Technol. J.* **27**:379-423.
168. **Shuldiner, A. R., A. Nirula, and J. Roth.** 1989. Hybrid DNA artifact from PCR of closely related target sequences. *Nucleic Acids Res* **17**:4409.
169. **Simpson, E.** 1949. Measurement of diversity. *Nature* **163**:688.
170. **Sing, A., A. M. Geiger, M. Hogardt, and J. Heesemann.** 2001. *Pneumocystis carinii* carriage among cystic fibrosis patients, as detected by nested PCR. *J Clin Microbiol* **39**:2717-8.
171. **Sing, A., A. Roggenkamp, I. B. Autenrieth, and J. Heesemann.** 1999. *Pneumocystis carinii* carriage in immunocompetent patients with primary pulmonary disorders as detected by single or nested PCR. *J Clin Microbiol* **37**:3409-10.
172. **Singer, C., D. Armstrong, P. P. Rosen, and D. Schottenfeld.** 1975. *Pneumocystis carinii* pneumonia: a cluster of eleven cases. *Ann Intern Med* **82**:772-7.
173. **Siripattanapipong, S., J. Worapong, M. Mungthin, S. Leelayoova, and P. Tan-ariya.** 2005. Genotypic study of *Pneumocystis jirovecii* in human immunodeficiency virus-positive patients in Thailand. *J Clin Microbiol* **43**:2104-10.
174. **Skold, O.** 2000. Sulfonamide resistance: mechanisms and trends. *Drug Resist Updat* **3**:155-160.
175. **Sloand, E., B. Laughon, M. Armstrong, M. S. Bartlett, W. Blumenfeld, M. Cushion, A. Kalica, J. A. Kovacs, W. Martin, E. Pitt, and et al.** 1993. The challenge of *Pneumocystis carinii* culture. *J Eukaryot Microbiol* **40**:188-95.
176. **Smittskyddsinstitutet.** [homepage on the internet]. Solna: Swedish Institute for Communicable Disease Control [updated 2011 Feb 11; cited 2011 June 03]. Available from: <http://www.smittskyddsinstitutet.se/sjukdomar/pneumocystisinfektion/>.
177. **Stein, C. R., C. Poole, P. Kazanjian, and S. R. Meshnick.** 2004. Sulfa use, dihydropteroate synthase mutations, and *Pneumocystis jirovecii* pneumonia. *Emerg Infect Dis* **10**:1760-5.
178. **Stringer, J. R.** 2007. Antigenic variation in pneumocystis. *J Eukaryot Microbiol* **54**:8-13.
179. **Stringer, J. R., C. B. Beard, R. F. Miller, and A. E. Wakefield.** 2002. A new name (*Pneumocystis jirovecii*) for *Pneumocystis* from humans. *Emerg Infect Dis* **8**:891-6.
180. **Stringer, J. R., and S. P. Keely.** 2001. Genetics of surface antigen expression in *Pneumocystis carinii*. *Infect Immun* **69**:627-39.

181. **Stringer, S. L., T. Garbe, S. M. Sunkin, and J. R. Stringer.** 1993. Genes encoding antigenic surface glycoproteins in *Pneumocystis* from humans. *J Eukaryot Microbiol* **40**:821-6.
182. **Stringer, S. L., S. T. Hong, D. Giuntoli, and J. R. Stringer.** 1991. Repeated DNA in *Pneumocystis carinii*. *J Clin Microbiol* **29**:1194-201.
183. **Stringer, S. L., J. R. Stringer, M. A. Blase, P. D. Walzer, and M. T. Cushion.** 1989. *Pneumocystis carinii*: sequence from ribosomal RNA implies a close relationship with fungi. *Exp Parasitol* **68**:450-61.
184. **Su, X. Z., V. M. Heatwole, S. P. Wertheimer, F. Guinet, J. A. Herrfeldt, D. S. Peterson, J. A. Ravetch, and T. E. Wellems.** 1995. The large diverse gene family var encodes proteins involved in cytoadherence and antigenic variation of *Plasmodium falciparum*-infected erythrocytes. *Cell* **82**:89-100.
185. **Sunkin, S. M., and J. R. Stringer.** 1996. Translocation of surface antigen genes to a unique telomeric expression site in *Pneumocystis carinii*. *Mol Microbiol* **19**:283-95.
186. **Sunkin, S. M., S. L. Stringer, and J. R. Stringer.** 1994. A tandem repeat of rat-derived *Pneumocystis carinii* genes encoding the major surface glycoprotein. *J Eukaryot Microbiol* **41**:292-300.
187. **Takahashi, T., N. Hosoya, T. Endo, T. Nakamura, H. Sakashita, K. Kimura, K. Ohnishi, Y. Nakamura, and A. Iwamoto.** 2000. Relationship between mutations in dihydropteroate synthase of *Pneumocystis carinii* f. sp. *hominis* isolates in Japan and resistance to sulfonamide therapy. *J Clin Microbiol* **38**:3161-4.
188. **Tamura, K., D. Peterson, N. Peterson, G. Stecher, M. Nei, and S. Kumar.** 2011. MEGA5: Molecular Evolutionary Genetics Analysis using Maximum Likelihood, Evolutionary Distance, and Maximum Parsimony Methods. *Mol Biol Evol*.
189. **Taylor, J. E., and G. Rudenko.** 2006. Switching trypanosome coats: what's in the wardrobe? *Trends Genet* **22**:614-20.
190. **Telzak, E. E., R. J. Cote, J. W. Gold, S. W. Campbell, and D. Armstrong.** 1990. Extrapulmonary *Pneumocystis carinii* infections. *Rev Infect Dis* **12**:380-6.
191. **Templeton, A. R., K. A. Crandall, and C. F. Sing.** 1992. A cladistic analysis of phenotypic associations with haplotypes inferred from restriction endonuclease mapping and DNA sequence data. III. Cladogram estimation. *Genetics* **132**:619-33.
192. **Thomas, C. F., Jr., and A. H. Limper.** 2007. Current insights into the biology and pathogenesis of *Pneumocystis pneumonia*. *Nat Rev Microbiol* **5**:298-308.
193. **Thomas, C. F., Jr., and A. H. Limper.** 2004. *Pneumocystis pneumonia*. *N Engl J Med* **350**:2487-98.
194. **Totet, A., J. C. Pautard, C. Raccurt, P. Roux, and G. Nevez.** 2003. Genotypes at the internal transcribed spacers of the nuclear rRNA operon of *Pneumocystis jiroveci* in nonimmunosuppressed infants without severe pneumonia. *J Clin Microbiol* **41**:1173-80.
195. **Tsolaki, A. G., R. F. Miller, A. P. Underwood, S. Banerji, and A. E. Wakefield.** 1996. Genetic diversity at the internal transcribed spacer regions of the rRNA operon among isolates of *Pneumocystis carinii* from AIDS patients with recurrent pneumonia. *J Infect Dis* **174**:141-56.
196. **Underwood, A. P., E. J. Louis, R. H. Borts, J. R. Stringer, and A. E. Wakefield.** 1996. *Pneumocystis carinii* telomere repeats are composed of TTAGGG and the subtelomeric sequence contains a gene encoding the major surface glycoprotein. *Mol Microbiol* **19**:273-81.

197. **Wada, M., K. Kitada, M. Saito, K. Egawa, and Y. Nakamura.** 1993. cDNA sequence diversity and genomic clusters of major surface glycoprotein genes of *Pneumocystis carinii*. *J Infect Dis* **168**:979-85.
198. **Wada, M., and Y. Nakamura.** 1996. Unique telomeric expression site of major-surface-glycoprotein genes of *Pneumocystis carinii*. *DNA Res* **3**:55-64.
199. **Wada, M., S. M. Sunkin, J. R. Stringer, and Y. Nakamura.** 1995. Antigenic variation by positional control of major surface glycoprotein gene expression in *Pneumocystis carinii*. *J Infect Dis* **171**:1563-8.
200. **Wakefield, A. E., A. R. Lindley, H. E. Ambrose, C. M. Denis, and R. F. Miller.** 2003. Limited asymptomatic carriage of *Pneumocystis jiroveci* in human immunodeficiency virus-infected patients. *J Infect Dis* **187**:901-8.
201. **Wakefield, A. E., S. E. Peters, S. Banerji, P. D. Bridge, G. S. Hall, D. L. Hawksworth, L. A. Guiver, A. G. Allen, and J. M. Hopkin.** 1992. *Pneumocystis carinii* shows DNA homology with the ustomycetous red yeast fungi. *Mol Microbiol* **6**:1903-11.
202. **Wakefield, A. E., F. J. Pixley, S. Banerji, K. Sinclair, R. F. Miller, E. R. Moxon, and J. M. Hopkin.** 1990. Detection of *Pneumocystis carinii* with DNA amplification. *Lancet* **336**:451-3.
203. **Valerio, A., E. Tronconi, F. Mazza, G. Fantoni, C. Atzori, F. Tartarone, P. Duca, and A. Cargnel.** 2007. Genotyping of *Pneumocystis jiroveci* pneumonia in Italian AIDS patients. Clinical outcome is influenced by dihydropteroate synthase and not by internal transcribed spacer genotype. *J Acquir Immune Defic Syndr* **45**:521-8.
204. **Walker, D. J., A. E. Wakefield, M. N. Dohn, R. F. Miller, R. P. Baughman, P. A. Hossler, M. S. Bartlett, J. W. Smith, P. Kazanjian, and S. R. Meshnick.** 1998. Sequence polymorphisms in the *Pneumocystis carinii* cytochrome b gene and their association with atovaquone prophylaxis failure. *J Infect Dis* **178**:1767-75.
205. **Walzer, P. D.** 1986. Attachment of microbes to host cells: relevance of *Pneumocystis carinii*. *Lab Invest* **54**:589-92.
206. **Walzer, P. D.** 1999. Immunological features of *Pneumocystis carinii* infection in humans. *Clin Diagn Lab Immunol* **6**:149-55.
207. **Walzer, P. D., D. P. Perl, D. J. Krogstad, P. G. Rawson, and M. G. Schultz.** 1974. *Pneumocystis carinii* pneumonia in the United States. Epidemiologic, diagnostic, and clinical features. *Ann Intern Med* **80**:83-93.
208. **van Hal, S. J., F. Gilgado, T. Doyle, J. Barratt, D. Stark, W. Meyer, and J. Harkness.** 2009. Clinical significance and phylogenetic relationship of novel Australian *Pneumocystis jirovecii* genotypes. *J Clin Microbiol* **47**:1818-23.
209. **van Oosterhout, J. J., M. K. Laufer, M. A. Perez, S. M. Graham, N. Chimbiya, P. C. Thesing, M. J. Alvarez-Martinez, P. E. Wilson, M. Chagomerana, E. E. Zijlstra, T. E. Taylor, C. V. Plowe, and S. R. Meshnick.** 2007. *Pneumocystis* pneumonia in HIV-positive adults, Malawi. *Emerg Infect Dis* **13**:325-8.
210. **Vanek, J., and O. Jirovec.** 1952. [Parasitic pneumonia. Interstitial plasma cell pneumonia of premature, caused by pneumocystis Carinii]. *Zentralbl Bakteriol Parasitenkd Infektionskr Hyg* **158**:120-7.
211. **Wang, P., M. Read, P. F. Sims, and J. E. Hyde.** 1997. Sulfadoxine resistance in the human malaria parasite *Plasmodium falciparum* is determined by mutations in dihydropteroate synthetase and an additional factor associated with folate utilization. *Mol Microbiol* **23**:979-86.
212. **Vargas, S. L., W. T. Hughes, M. E. Santolaya, A. V. Ulloa, C. A. Ponce, C. E. Cabrera, F. Cumsille, and F. Gigliotti.** 2001. Search for primary infection

- by *Pneumocystis carinii* in a cohort of normal, healthy infants. *Clin Infect Dis* **32**:855-61.
213. **Vargas, S. L., C. A. Ponce, F. Gigliotti, A. V. Ulloa, S. Prieto, M. P. Munoz, and W. T. Hughes.** 2000. Transmission of *Pneumocystis carinii* DNA from a patient with *P. carinii* pneumonia to immunocompetent contact health care workers. *J Clin Microbiol* **38**:1536-8.
  214. **Vargas, S. L., C. A. Ponce, C. A. Sanchez, A. V. Ulloa, R. Bustamante, and G. Juarez.** 2003. Pregnancy and asymptomatic carriage of *Pneumocystis jirovecii*. *Emerg Infect Dis* **9**:605-6.
  215. **Vidal, S., C. de la Horra, J. Martin, M. A. Montes-Cano, E. Rodriguez, N. Respaldiza, F. Rodriguez, J. M. Varela, F. J. Medrano, and E. J. Calderon.** 2006. *Pneumocystis jirovecii* colonisation in patients with interstitial lung disease. *Clin Microbiol Infect* **12**:231-5.
  216. **Wissmann, G., M. J. Alvarez-Martinez, S. R. Meshnick, A. R. Dihel, and J. C. Prolla.** 2006. Absence of dihydropteroate synthase mutations in *Pneumocystis jirovecii* from Brazilian AIDS patients. *J Eukaryot Microbiol* **53**:305-7.
  217. **Volpe, F., M. Dyer, J. G. Scaife, G. Darby, D. K. Stammers, and C. J. Delves.** 1992. The multifunctional folic acid synthesis *fas* gene of *Pneumocystis carinii* appears to encode dihydropteroate synthase and hydroxymethyldihydropterin pyrophosphokinase. *Gene* **112**:213-8.
  218. **Worodria, W., M. Okot-Nwang, S. D. Yoo, and T. Aisu.** 2003. Causes of lower respiratory infection in HIV-infected Ugandan adults who are sputum AFB smear-negative. *Int J Tuberc Lung Dis* **7**:117-23.
  219. **Wright, T. W., T. Y. Bissoondial, C. G. Haidaris, F. Gigliotti, and P. J. Haidaris.** 1995. Isoform diversity and tandem duplication of the glycoprotein A gene in ferret *Pneumocystis carinii*. *DNA Res* **2**:77-88.
  220. **Wright, T. W., F. Gigliotti, J. N. Finkelstein, J. T. McBride, C. L. An, and A. G. Harmsen.** 1999. Immune-mediated inflammation directly impairs pulmonary function, contributing to the pathogenesis of *Pneumocystis carinii* pneumonia. *J Clin Invest* **104**:1307-17.
  221. **Wyder, M. A., E. M. Rasch, and E. S. Kaneshiro.** 1998. Quantitation of absolute *Pneumocystis carinii* nuclear DNA content. Trophic and cystic forms isolated from infected rat lungs are haploid organisms. *J Eukaryot Microbiol* **45**:233-9.
  222. **Yale, S. H., and A. H. Limper.** 1996. *Pneumocystis carinii* pneumonia in patients without acquired immunodeficiency syndrome: associated illness and prior corticosteroid therapy. *Mayo Clin Proc* **71**:5-13.
  223. **Yoshida, Y., Y. Matsumoto, M. Yamada, K. Okabayashi, H. Yoshikawa, and M. Nakazawa.** 1984. *Pneumocystis carinii*: electron microscopic investigation on the interaction of trophozoite and alveolar lining cell. *Zentralbl Bakteriol Mikrobiol Hyg A* **256**:390-9.
  224. **Zar, H. J., A. Dechaboon, D. Hanslo, P. Apolles, K. G. Magnus, and G. Hussey.** 2000. *Pneumocystis carinii* pneumonia in South African children infected with human immunodeficiency virus. *Pediatr Infect Dis J* **19**:603-7.