

Treatment of movement disorders using deep brain stimulation – illustrative case reports and technical notes

Stimulacija globokih možganskih jeder za zdravljenje motenj gibanja – prikaz primerov in tehničnih izboljšav

Tadej Strojnik,¹ Dušan Flisar,² Igor Drstvenšek³

¹ University Clinical Centre Maribor, Department of Neurosurgery, Ljubljanska 5, SI-2000 Maribor, Slovenia

² University Clinical Centre Maribor, Department of Neurology, Ljubljanska 5, SI-2000 Maribor, Slovenia

³ University of Maribor, Faculty of Mechanical Engineering, Smetanova ulica 17, SI-2000 Maribor, Slovenia

Korespondenca/ Correspondence:

assoc. prof. Tadej Strojnik, MD, PhD, University Clinical Centre Maribor, Department of Neurosurgery, Ljubljanska 5, SI-2000 Maribor, Slovenia
E mail: tadej.strojnik@ukc-mb.si

Abstract

Operative neuromodulation is the field of electrically or chemically altering the signal transmission in the nervous system by implanted devices in order to excite, inhibit or tune the activities of neurons or neural networks to produce therapeutic effects. Deep brain stimulation (DBS) is an important component of the therapy of movement disorders and has almost completely replaced high-frequency coagulation of brain tissue in stereotactic neurosurgery. This article presents the first DBS cases in Slovenia. In the article the technical features and adjustments of magnetic resonance (MR) imaging and development of a new microdrive, which was clinically successfully tested, are described and discussed.

Introduction

Neuromodulation can be defined as the process by which chemical substances, neurons or neural networks excite, inhibit or tune adjacent or remote neurons or neural networks in order to stimulate the latter to deliver responses which are better adapted to the demands of the environment of an organism.¹ In the clinical context, neuromodulation implies the implantation of a device by the therapist into the body of the patient. Neuromodulation therapy has inevitably an interventional or operational character, so it is more accurate to

Izveček

Operacijska nevromodulacija je reverzibilna uporaba električne stimulacije ali dovajanje farmakoloških snovi v osrednji živčni sistem z vgradnjo naprave v bolnikov telo. Namen je spreminjati aktivnost živčnega sistema (ekscitacija, inhibicija ali prilagajanje nevronov ali nevronske mreže) za zdravljenje specifičnih stanj. Globoka možganska stimulacija (GMS) je pomembna metoda za zdravljenje gibalnih motenj in je skoraj popolnoma nadomestila visokofrekvenčno koagulacijo možganovine. V članku predstavljamo prve slovenske primere GMS. Predstavili smo tehnične posebnosti in prilagoditve pri uporabi magnetne resonance ter razvoj novega mikrovočila, ki smo ga uspešno klinično preizkusili.

name this therapy as *Operative Neuromodulation*.¹ Deep brain stimulation (DBS) is a surgical procedure that allows implanting microelectrodes precisely in some brain areas through a combination of stereotactic and neuroimaging techniques.² A subcutaneous external pacemaker lets these electrodes exert direct chronic, high frequency electrical stimulation to specific targets in the brain.^{2,3} Yet, the precise mechanism of action of DBS remains uncertain.⁴ The axonal activation hypothesis proposes that DBS evokes changes in neural activity and neurochemical transmission in interconnected structures within the basal ganglia complex

Ključne besede:

stereotaksija, operativna nevromodulacija, Parkinsonova bolezen, magnetna resonanca, mikrovodilo

Key words:

Stereotaxy, Operative Neuromodulation, Parkinson's disease, MR imaging, Microdrive

Citirajte kot/Cite as:

Zdrav Vestn 2012; 81: 422–34

Prispelo: 7. sept. 2011,
Sprejeto: 18. mar. 2011

that ultimately underlie clinical benefit.^{5–9} DBS may activate multiple neurotransmitter systems, including glutamate and adenosine, which probably play the role in the therapeutic mechanism of DBS.^{4,5} DBS has become an established surgical treatment for movement disorders (e.g., Parkinson's disease (PD), essential tremor and dystonia), and is in trials for refractory epilepsy, headache, and certain mood disorders.^{10–17} The development of DBS as we know it today started with the publications of Benabid, Pollak et al in 1987 on thalamic DBS for tremor.^{18,19} The progress of DBS technology depends on better understanding of the mechanism of action of DBS, improvements in neuroimaging and technical development of the equipment. For example, treating advanced PD with DBS is greatly facilitated by direct visualization of brain nuclei, which often involves indirect approximations of stereotactic targets.^{20,21} An important part of the DBS procedure is also microelectrode recording (MER), which requires a precise placement of the microelectrodes within the brain.^{22–24} DBS is an important component of the therapy of movement disorders and has almost completely replaced high-frequency coagulation of brain tissue. The latter was used in Ljubljana in the eighties. In Slovenia the first DBS procedure was performed in Maribor on April 24, 2008; since then, six patients have been treated successfully.²⁵ The evolution of our technique is presented on three illustrative PD patients. We compared planning on T2-weighted images obtained by 1.5 Tesla (T) Magnetic resonance (MR) imaging with those obtained by Fluid-Attenuated Inversion Recovery (FLAIR) 3T MR imaging to ascertain whether 3T imaging enables better visualization of targets for DBS in PD.

Microdrive is an apparatus useful with a stereotactic assembly or an equivalent apparatus to hold and direct a surgical instrument into a target. A new microdrive was developed which, in our opinion, significantly shortens the duration of the operation and enables us to achieve more precise microelectrode placement.

Case reports

Case 1

R. S. who was living alone and working on a farm developed symptoms of PD nine years prior to the surgery. His mother had also suffered from PD. In the first seven years his illness was well controlled with medications, but then motor fluctuations and severe dyskinesia emerged. At night he also suffered from severe tremor and twisting of the body. He became completely dependent and was waiting to be admitted to a retirement home. Clinical data and treatments are summarized in Tables 1–3.

DBS was offered to the patient and he accepted the operation. Pre-operative assessment included psychological testing. Dementia and severe depression were excluded. Two days before surgery MRI scanning without a frame was done on a Signa Excite 1.5 Tesla General Electric Scanner (GE, Waukesha, Wisconsin, USA). The patient was sedated under the supervision of an anaesthesiologist. T1 contrast enhanced axial 3D slices as well as T2 coronal slices were carried out (Table 4). On the morning of the surgery, a stereotactic head ring (MHT, Freiburg, Germany) was placed on the patient's head. Then the patient was transferred to the Radiology Department where a computed to-

Table 1: Patients' general data.

No.	Age (years)	Gender	Occupation	Duration of PD (years)	Comments
1	59	male	farmer	9	completely dependent patient
2	56	male	farmer	17	last 5 years – motor fluctuations and dyskinesia during the "on" state
3	57	male	pensioner	7	highly asymmetric left-sided PD

Figure 1a and b: A T1 weighted magnetic resonance image of anterior commissure (arrow) (a) and posterior commissure (arrowhead) (b). Both coordinates are needed for indirect planning.

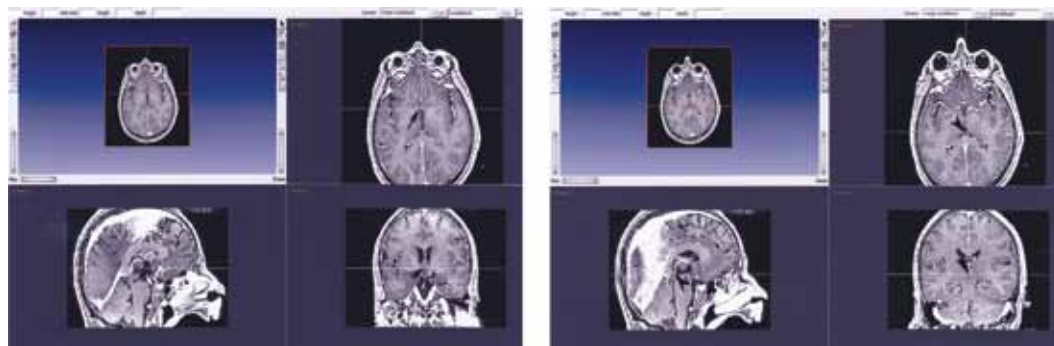

mography scan (CT) was performed (Aquilion, Toshiba, Tokyo, Japan). One mm slices were done from the base of the ring to the top of the head. The gantry was 0 degrees. After scanning, the patient was transferred to an operating theatre and positioned on the operating table. Every attempt was made to make him feel as comfortable as possible. The vital signs were continuously monitored and he was under the anaesthetist's surveillance. At the same time all the images were transferred to a graphics workstation for multiplanar trajectory planning (Amira, Visage Imaging, Berlin, Germany). CT and MR images were fused in order to plan the surgery from MR images despite the fact that the scanning was done without the frame attached. The coordinates for the target points and the burr holes were calculated for ideal trajectories. First, the coordinates for the left

and for the right subthalamic nucleus (STN) were calculated using indirect method (Figure 1a and 1b). The coordinates for anterior commissure (AC) and posterior commissure (PC) were set and then the line between these two points was determined. STN is located 2 mm behind the mid-commissural point, 4 mm below and 12 mm lateral of the AC-PC line. The stereotactic coordinates for the STN are summarized in Table 5. Both entry points were set in front of the coronary suture and the coordinates were calculated for the trajectory to avoid vessels and the ventricles. All coordinates were again verified using a phantom. After confirming the right trajectory, the aiming bow unit was removed from the phantom and transferred to the stereotactic frame fixed on the patient's skull. The skin incision site was infiltrated with local anaesthetics and the first burr

Table 2: Pre- and post-operative treatments of patients (drugs in mg and times per day).

Medicaments	No. 1		No. 2		No. 3	
	before	after	before	after	before	after
levodopa/carbidopa	200/50 (4x)	0	100/25 (4x)	100/25 (4x)	0	0
levodopa/carbidopa/entacapone	0	150/37.5/200 (5x)	0	0	0	0
ropinorole (conventional form)	5 (3x)	0	0	0	0	0
ropinorole (retard form)	0	20 (1x)	22 (1x)	0	0	0
amantadine	100 (3x)	0	100 (2x)	0	0	0
levodopa/benserazide	0	0	0	0	200/50 (5x)	0
entacapone	0	0	0	0	200 (5x)	0
rasagiline	0	0	0	0	1 (1x)	0
pramipexole	0	0	0	0	1.57 (1x)	1.57 (1x)

Figure 2: Conventional microdrive. Component (1) is a guide for rough positioning of the instrument onto a stereotactic frame, this component is bound to the main body (12) through part (2). The main body is made of two parts assembled with a screw. Component (4) is an instrument guide set in place with a screw. Part (5) is the nut, which moves over a guiding part situated at the bottom of the nut by turning the screw (9). Component (7) is an instrument holder through which the tubes are tightened by component (6) made of aluminum. The tightening is achieved by turning a small screw with a special wrench. The black box (10) in the back is a gear box with a belt through which, by turning the knob (13), the screw (9) rotates. The last major component is a long bar (11) with an instrument guide at one end. Another end can move through the body (12) as long as it is fixed by a screw to hold the shortest possible distance between the patient's head and the microdrive.

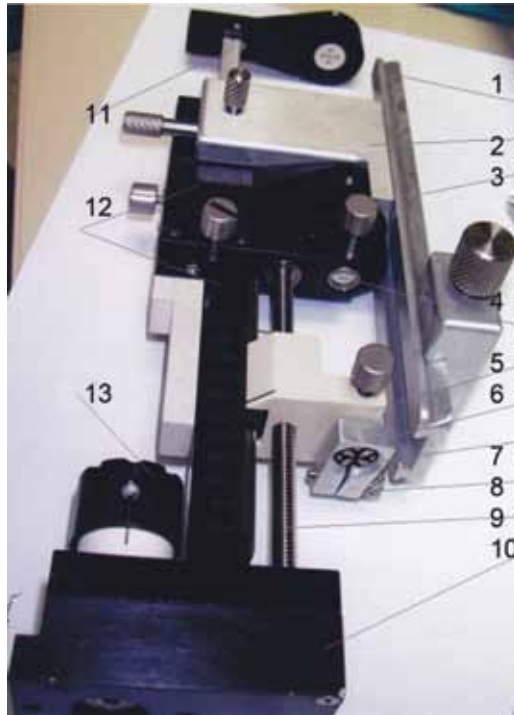

hole was drilled. A Stimlock plastic ring, (Medtronic Inc., Minneapolis, Minnesota, USA) which is used for the fixation of permanent electrodes, was fixed with two small screws into the burr hole. A Medtronic based microdrive (FHC microTargeting, Bowdoinham, Maine, USA) was installed on the aiming bow (Figure 2). The depth was set to 20, which was 10 mm above the target. The dura was opened and five insertion tubes for microrecording electrodes (Medtronic Inc., Minneapolis, Minnesota, USA) were carefully introduced into the brain. Then the microrecording electrodes (Medtronic Inc.,

Minneapolis, Minnesota, USA) were passed through the tubes and connected via micro-electrode recording cable (Medtronic Inc., Minneapolis, Minnesota, USA) with the recording device (LeadPoint Medtronic Inc., Minneapolis, Minnesota, USA) and grounded. The microelectrodes were advanced in a stepwise manner by 1 mm and electric potentials were recorded. During this stage of the procedure reliable performance of the microdrive is required. Unfortunately, smooth performance of the common, commercially available microdrive was not achieved because of its relatively complicated and delicate construction, which caused a delay during the operation. Finally, upon reaching the target the neurophysiologist noticed the characteristic potentials. At that time the patient became restless and was given midazolam by the anaesthesiologist. This resulted in the reduction of electric potentials and no further convincing signals could be recorded. Nevertheless, test stimulation was started and clinical evaluation of the effect of the stimulation was performed by the attending neurologist. The patient was awake and cooperated with the neurologist. After a satisfactory response was achieved with no additional side effects, the best microelectrode was selected. It was replaced by a permanent electrode (DBS Lead Kit -28 cm, Medtronic Inc., Minneapolis, Minnesota, USA), which was fixed using the Stimlock (Figure 3). The distal part of the electrode was then left in the subgaleal pocket and the

Table 3: Clinical data.

No.	Before surgery			After surgery	
	UPDRS III		Comments	UPDRS III	Comments
	Off	On			
1	60	11	severe dyskinesia in on state	18	no dyskinesia, independent, right side resting tremor
2	50	11	not able to walk in off period	5	independent
3	53	20	after a challenge with levodopa/carbidopa	6	independent

Legend: UPDRS III: motor part of the Unified Parkinson's Disease Rating Scale, part III

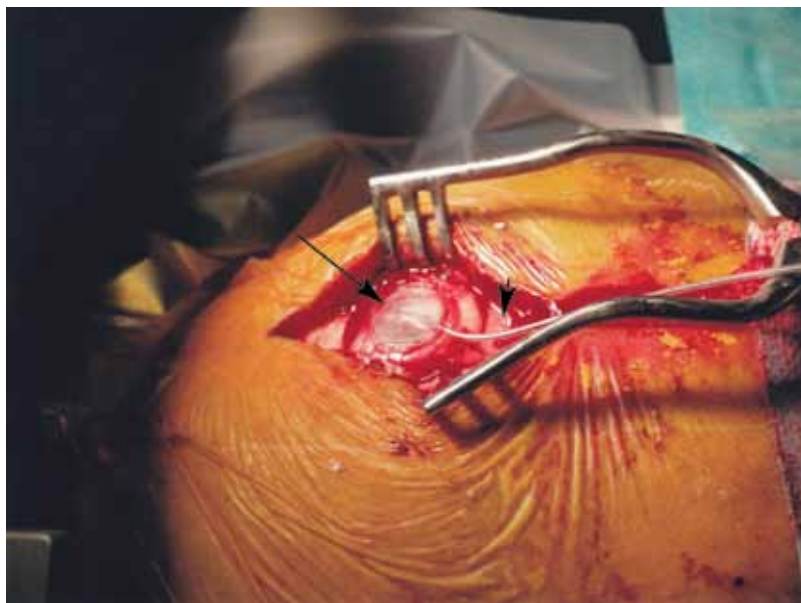

Figure 3: Stimlock fixation device (arrow) with permanent electrode (arrowhead).

wound closed. The same procedure was repeated on the right side. We encountered the same problems with the microdrive, but the effect of midazolam had resolved by then and we obtained very good potentials from the right STN. A permanent electrode (DBS Lead Kit–40 cm, Medtronic Inc., Minneapolis, Minnesota, USA) was introduced. After

placing both electrodes another stereotactic CT scan was performed. The position of the electrodes was checked and compared with the planning coordinates. We found that the left electrode was too deep and was repositioned appropriately by the simple retraction under x-ray control. After confirming the symmetrical position of both electrodes (Figure 4), the patient was intubated and put under general anaesthesia. An implantable pulse generator (IPG) (Kinetra, Medtronic Inc., Minneapolis, Minnesota, USA) was implanted under the left clavicle and connected via extension wires (Medtronic Inc., Minneapolis, Minnesota, USA) to both electrodes. The duration of the operation was 14 hours. The postoperative period was uneventful and after seven days the patient was transferred back to the neurology department for programming. After stimulation, the results on the left side were excellent with no symptoms of PD. On the right side there was still a rest tremor in his hand, visible especially during walking. Muscle tone in the right arm was also increased and there was still right-sided bradykinesia (Unified Parkinson's

Table 4: Characteristics of MRI sequences according to the protocol of Radiology Department, UCC Maribor.

Parameter	1.5T MRI scanner		3T MRI scanner
	T1 axial 3D slices	T2 coronal slices	FLAIR sagittal T2 cube sequences
Frequency	320	256	288
Phase	192	256	288
Number of excitations (NEX)	3.00	4.00	1.00
Time echo (TE)	1.7	102.0	121
Time repetition (TR)	/	6000	3000
Echo train length (ECL)	/	100	100
Flip Angle	25	25	31.2
Bandwidth	19.23	20.83	62.50
Field of view (FOV)	24.0	24.0	24.0
Slice thickness	1.0	1.5	1.0
No. of slices	160	168	165
Scan time in minutes	13	20	6

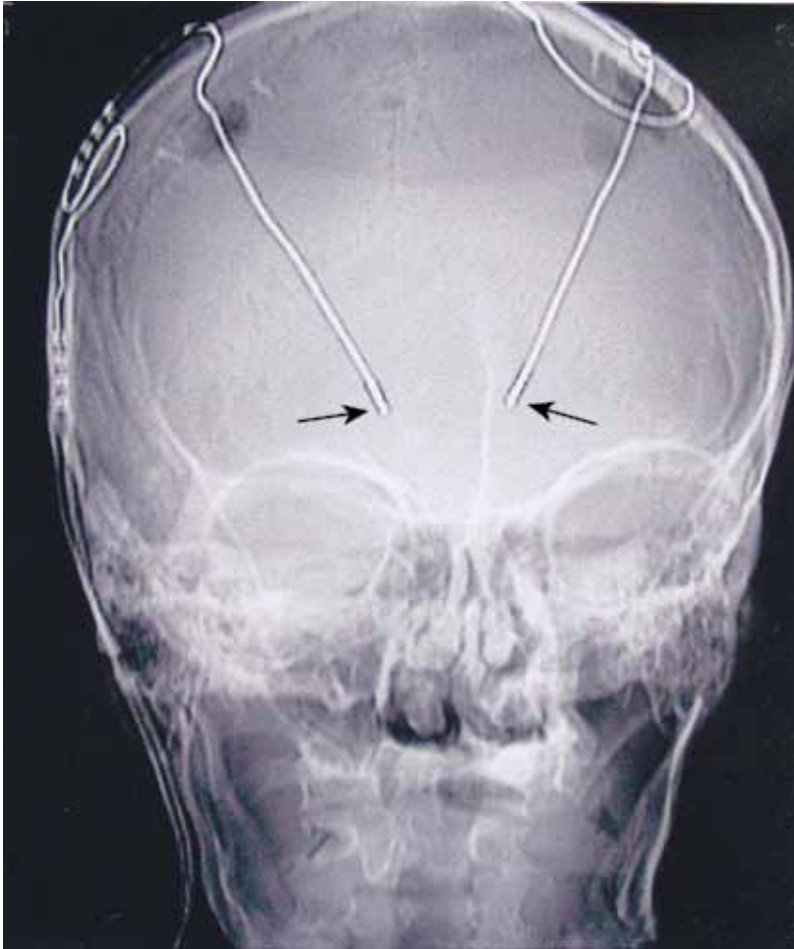

Figure 4: X ray of the skull showing symmetrical position of both electrodes (arrows).

Disease Rating Scale (UPDRS) III 2 points). We were able to reduce tremor by increasing the intensity of stimulation, but this resulted in a further increase in the muscle tone of his right limbs. By trying several stimulation parameters and using a bipolar mode of stimulation we were still not able to completely eliminate this side effect. A compromise had to be made and the patient was discharged with the resting tremor on the right side. However, his overall PD improved substan-

tially. With stimulation on and an additional oral antiparkinsonian medication his UPDRS III score became 18 points with no troublesome dyskinesia. Because of the high intensity of stimulation the battery had to be replaced after only two years. We therefore decided to reduce the intensity of stimulation and increase the dopaminergic therapy (Table 2 and 3). Although the effect of the operation on the right side is not optimal, three years later the patient is still capable of living alone and cares for himself on a remote farm on the Pohorje Mountain. Although his quality of life has clearly improved, a re-implantation of the left electrode was being strongly considered. Recently, the patient successfully underwent the second operation and the left electrode was replaced. The position of the new electrode is now precisely within the left STN.

Case 2

In J. S. the symptoms of PD started 17 years ago. During the last 5 years he had pronounced motor fluctuations and dyskinesia during the on state. In the off period there was severe rigidity and bradykinesia in all of his limbs accompanied by a resting tremor in his hands (Tables 1–3). The patient was offered bilateral STN stimulation. Preoperative MRI scanning without a frame was done on a Signa HDxt 3Tesla Scanner (General Electric, Waukesha, Wisconsin, USA). The patient was sedated under the supervision of an anaesthesiologist. FLAIR sagittal T2 cube sequences were carried out (Table 4). On the day of the surgery the head ring was attached and a CT scan was performed.

Table 5: The coordinates for the subthalamic nucleus (STN): the indirect calculations and direct visualization.

No.	Side of STN	Coordinates–indirect method			Coordinates – direct method		
		x	y	z	x	y	z
1	left	-14	+2	56	/	/	/
	right	+10.5	+1.5	58.5	/	/	/
2	left	-12	-6	43.5	-11	-7	43
	right	+7	-7	43	+7	-8	43
3	right	+12	-4	38	+11	-6	37

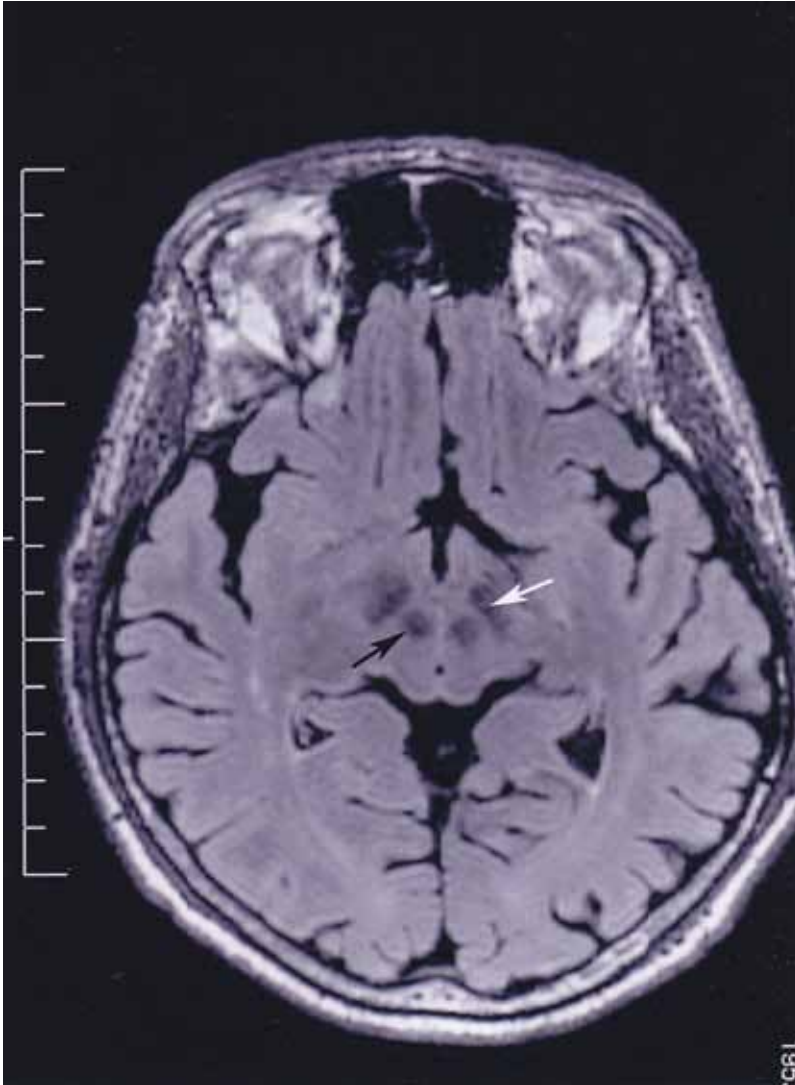

Figure 5: Subthalamic nucleus (white arrow) and nucleus ruber (black arrow) as seen on FLAIR sagittal T2 cube sequences obtained on a 3T MR scanner.

MR and CT images were fused for planning. Using this MR technique, we were able to directly visualize the STN and perform the planning directly (Figure 5). This was done by pointing at the STN directly and confirmed by measuring a distance of 3 mm from the nucleus ruber, which was also clearly visible. We compared these direct coordinates with the indirect ones, which were calculated as described in the first case (Table 5). Since the overlap of the results was excellent, we proceeded with the operation as in the previous case. We again encountered the same problems with the microdrive as in the previous case, which resulted in a prolongation of the operation time. Otherwise, no complications occurred and we achieved very good microelectrode potentials. This allowed us to place the permanent electrodes precisely. The position of the electrodes

was checked after both electrodes were implanted with another stereotactic CT (Figure 6). After confirming the correct position of the electrodes, the patient underwent IPG implantation under general anaesthesia. The operation time was 11 hours. The postoperative course was uneventful and after 7 days the patient was transferred to the neurology department for programming. Two years after the surgery the patient is at home. He is independent and able to deal with farm machinery (Table 2 and 3). His dyskinesia, rigor and tremor have almost completely resolved. Only slight bradykinesia remains, which is apparent during the toe-tapping test. Because his emotional stability is very dependent on levodopa intake, his dopaminergic medication was not reduced. The patient and his family are very satisfied with the outcome of the operation.

Case 3

L. D. became ill 7 years ago with a clinical picture of highly asymmetric left-sided PD. The main symptoms were an irregular resting tremor in his left upper extremity, rigor and bradykinesia. There were also painful stiffness and cramps in the muscles of the left shoulder resembling dystonia. In addition, he presented with marked stiffness of the left leg and a limping gait. Clinical data and treatments are summarized in Tables 1–3. The response to his therapy had been inadequate so he was proposed to undergo the right-sided STN stimulation.

Before surgery, a psychological evaluation was performed, which excluded depression and dementia. Preoperative MRI scanning was done on a 3T MRI scanner (Table 4). During surgery, direct and indirect planning was used to determine the coordinates of the right STN (Table 5). During the operation on the non-sedated patient the same operative technique was used as described in the previous patients. However, this time we were using a newly developed microdrive (Ortotip Ltd, Maribor, Slovenia), which was developed and patented in collaboration between our neurosurgical department (author T. S.), company Ortotip Ltd, and the Faculty of Mechanical Engine-

Figure 6: After placing both electrodes, control stereotactic CT scan is performed. Position of the electrodes is checked and compared with the planning coordinates (arrows).

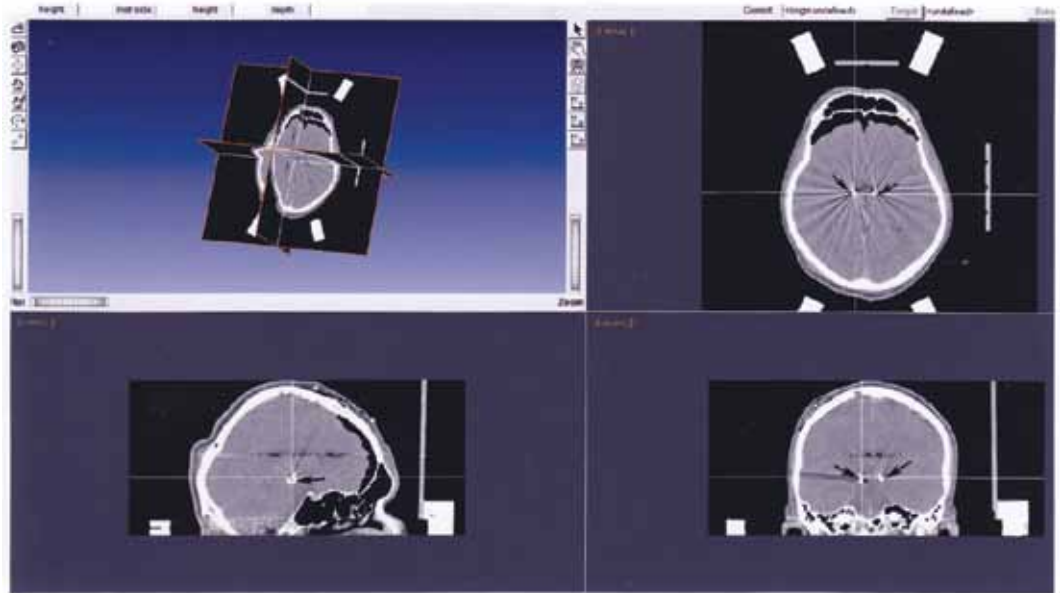

ering (author I. D.).^{26,27} The new one as well as other available microdrives are described in Discussion. There were fewer problems with the assembling of our microdrive. In addition, a newly developed head on the microdrive, which holds the microelectrode tubes, prevented jamming, which we encountered before (Figure 7a and 7b). The new holder employs a threaded collet chuck to clamp the tubes instead of a hollow clamp with laterally positioned standard screw of the conventional microdrive that applies an asymmetric clamping force to the tubes. Moreover, it requires a use of special – additional – tools for tightening the clamp, whereas the new holder enables a toolless and flawless tightening by a single turn of the collet chuck using only fingertips. This time the introduction of microelectrodes went smoothly. After the permanent electrode was introduced and secured with the Stimlock a control CT scan was performed. The images were fused with preoperative MR images and we confirmed the exact position of the electrode in the right STN (Figure 8). Finally, the IPG was implanted under general anaesthesia. The total operative time with all the scanning and calculations was 5 hours. The postoperative course was uneventful and after seven days the patient was transferred for programming to the neurology department. Three months after the surgery the patient is at home. He is independent and capable of working in the garden and in

the house. There is no rigor or bradykinesia on his left side. Only occasionally can a mild resting tremor of the left upper extremity be noticed, but this does not disturb the patient very much. His gait improved completely and he is no longer experiencing painful cramps in his left shoulder (Tables 2 and 3).

Discussion

One of the challenges associated with DBS in treating advanced PD is the direct visualization of the brain nuclei, which often involves indirect approximations of stereotactic targets.²⁰ During the first procedures we were using indirect planning based on T2 images obtained on a 1.5 T MR Scanner. The images were 1.5 mm thick and very grainy, so no nuclei could be seen on the images (Figure 9). We could only estimate the position of the STN. Recently, we began to use our new 3T MR scanner and special FLAIR sequences, which gave us superior results in terms of visualizations of deep brain nuclei. But, because of the higher distortion in the 3T magnetic field, we were worried about the accuracy of those images. Fortunately, this was not a problem in our patients; namely, postoperative stereotactic CT fused with MR images revealed the exact position of the electrodes within the STN. We also compared indirect planning with direct planning on FLAIR 3T MR images. The results were nearly identical. In our experien-

Figure 7: New microdrive enabling a smooth introduction of microelectrodes. (Fig 7a) An isometric view of an instrument (9) micro positioning device on the stereotactic system, which includes the device frame with the linear drive for positioning of the instrument (9). The fixation device consists of collet sections (6') and associated taper nut (7'). Collet sections form five bores for fixation and micropositioning of the instruments. By threading of the taper nut on to the collet, the effective diameter of the fixation system bore is reduced, while the friction force between the instrument and the fixation system, which fixes the instrument on the linear drive of the device increases; the fixation system of the device as well as the instrument moves due to the movement of the device or the linear drive. The following items are also shown: bracket (1), guide-bar (2), button (3), threaded-nut (5), central-spacer (8'). The unique or novel solution in this design is a collet chuck system (Fig 7b). The elements are shown in the dismounted position: spacer (6') with an integrated multi-object spring collet (6'a) acting as a compressible tapered-neck with associated taper-nut (7'), and the collet-bracket (6'b).

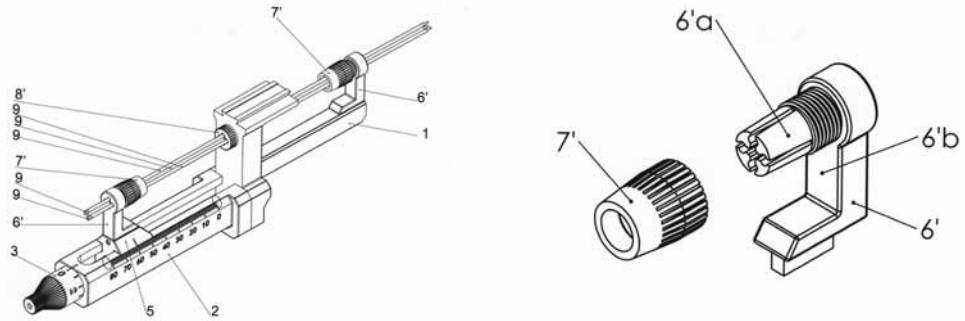

ce, the 3T imaging enables better visualization of targets for DBS in PD and comparable accuracy. It is certainly advantageous for the clinician to actually visualize that part of the nuclei where he is going to place the electrode. Finally, the use of direct planning is also faster, which is important and significantly contributes to shortening of the total operation time. In some centres they have even stopped using MER which, in our opinion, can be justified only in selected cases where the patient is not able to cooperate during surgery, and the procedure has to be done under general anaesthesia.²⁸ In general, intraoperative MER and clinical evaluation is still considered to be very important for a successful operation and correct electrode placement.²⁹⁻³² During the DBS procedure, which requires multidisciplinary approach (neurosurgeon, neurologist, neurophysiologist, anaesthesiologist, specialized scrub nurse...), it is very important that all members of the team collaborate well and also that the equipment is working properly.

As mentioned earlier, a good microdrive is essential for successful operation. Documentation of the first microdrive invented by Warner N., Goddard M. and Mills J. was internationally published under the patent cooperation treaty in the year 1996 (patent US5871487). The first microdrive consists of several parts. As the years passed by, the microdrive evolved and different companies that produce medical equipment now have their own models of the device. The Elekta's microdrive is based on a simple concept of advancing the tubes (instruments) and penetrating the brain of transforming a rotating motion into a linear motion using a screw and a nut. The device assembled on the guiding frame reveals a considerable

disadvantage of Elekta's microdrive hidden in the principle of clamping the electrodes. They have to be tightened into the holding ring with thin tiny screws, which leads to tightening a total of ten screws in the middle of the surgery where, worst of all, this tightening has to be done with a special adequately tiny key. On the other hand, this type of fixation also allows the surgeon to loosen only one tube at a time so that the other ones would not move. Integra NeuroSciences provides the market with an instrument driving system built to lead only one instrument for biopsy. The only advantage of this instrument is at the same time its main disadvantage; namely, it is equipped with an electronic measuring device and digital display, which makes readings easier for the surgeon but renders sterilization an extremely awkward procedure. Another disadvantage lays in the fact that the instrument has to be pushed manually without any transmission system that would make it relatively precise. AlphaOmega Company has a variety of microdrive devices with different specifications. Neurodrive is a small, light-weight, preassembled microdrive. This innovative drive features a virtually noise-free motor allowing the surgeon to record as the electrodes are advanced in the brain. For a backup action, it is also equipped with a manual override. Electrically driven microdrive might seem as a good idea but is hard to sterilize. The microdrive that was previously used in the University Clinical Centre in Maribor is a Medtronic-based FHC microTargeting design (Figure 2). The instrument consists of many small parts, which have to be disassembled for sterilization purposes. Their shape is very unintuitive making it extremely hard to assemble

Figure 8: Postoperative stereotactic CT fused with preoperative MR images shows the exact position of the electrode in the right subthalamic nucleus (arrow).

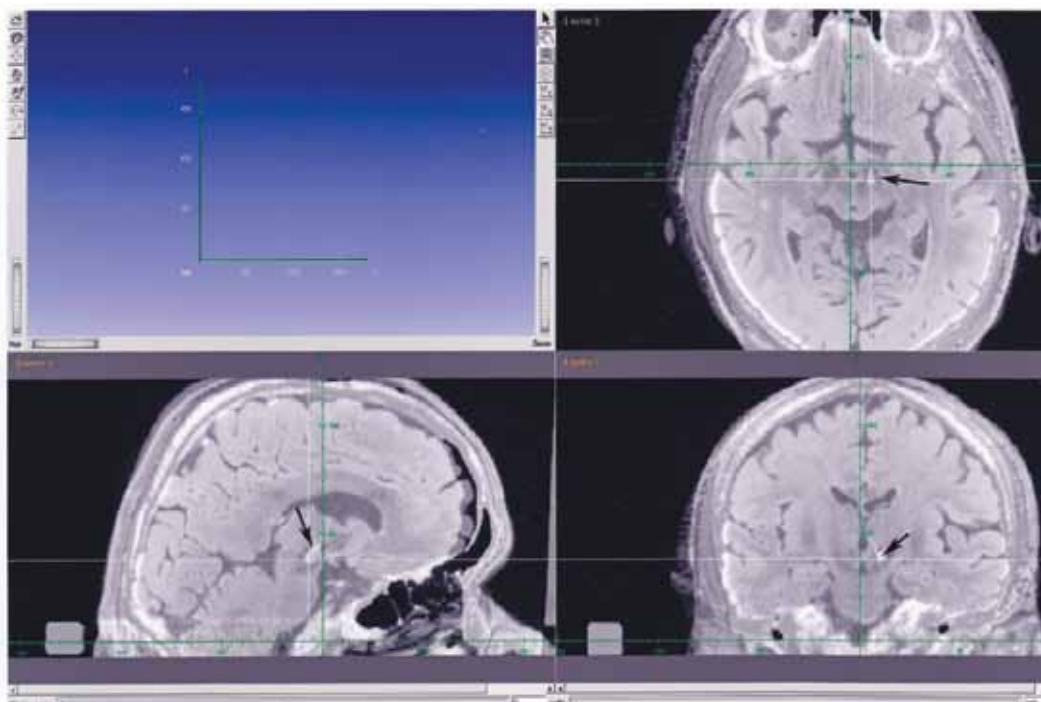

a device in the operating theatre with all the gloves and protective means being in use at the time of operation. Practical use of the microdrive has on several occasions revealed some serious engineering errors that caused repeated malfunctions of the microdrive during a neurosurgical procedure. The instruments' tightening system is very unpractical where releasing the force of tightening leads to a possible unwanted fall of a part. All outside head screws with long necks can lead to possible stumbling of the surgeon against them. Besides, they are meant to be tightened manually, which is a very optimistic expectation, bearing in mind the surgeon's protective gloves and the small diameter of the screw's head. The instrument's guide is positioned relatively and unnecessarily deep into the body, which makes an unwanted jamming of the instruments into the edge of the surrounding tube possible. This can be neither seen nor noticed by any means because it is always hidden by a stereotactic frame and the transmission ratio is too high to notice an increase in the torque before the instruments already push the body parts apart, which leads to disruption of the surgical process and repeated positioning of the device. The last disadvantage of the presented design is a large number of pieces that the body is made of, which need

to be assembled inside the operation theatre under sterile conditions. After analyzing the existing device and other solutions available in the market, a decision was made to design and produce a new microdrive that would address and resolve all of the above mentioned problems:

- designing a new mechanism for tightening the tubes and eliminating the problem of jamming of the tubes;
- repositioning the rotating knob for better handling;
- eliminating the need of assembling the components by the surgeon right before operation;
- replacing the fixing screws with a more practical solution to avoid the possibility of buckling;
- the design should not require any additional tools to operate the device.

The solution has been compiled out of many well known principles that can also be seen among the devices already present in the market with some unique approaches and solutions that enabled the authors to file a patent application under the patent cooperation treaty at WIPO with the number PCT/SI2010/000060, patent number 2011/053259.^{26,27}

The disclosed solution is shown in Figure 7a. The unique or novel solution in this

Figure 9: T2 images obtained on a 1.5 T MR Scanner, which were used for planning in our first operations. The images are very grainy and no nuclei can be reliably seen on these images.

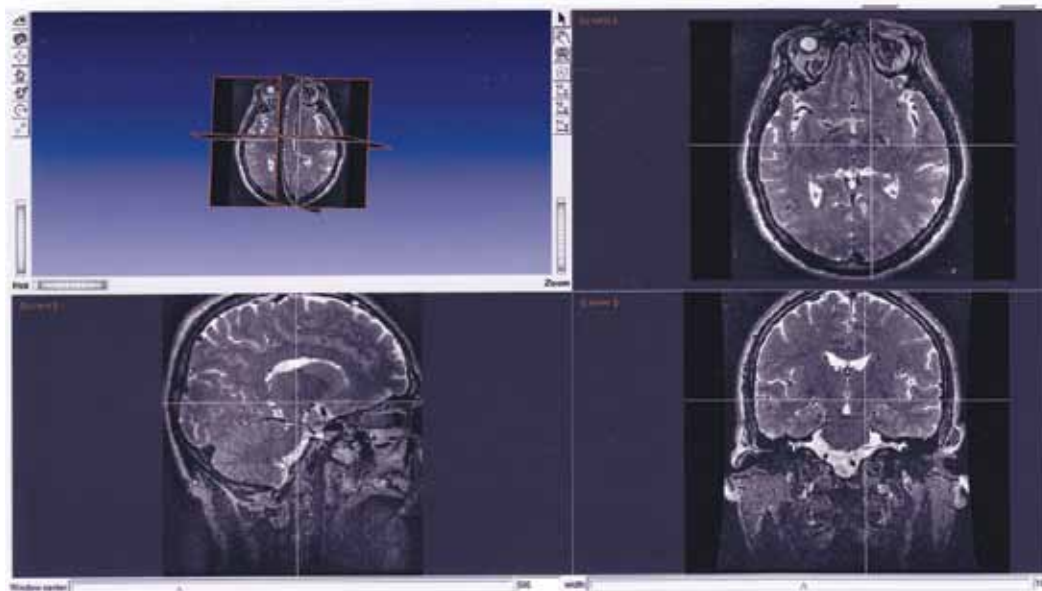

design is a collet chuck system shown in Figure 7b. A similar solution can be found in the machine tool branch where it is used for clamping cylindrical mills and drills into the machine tool's spindle. The similarity ends after the four additional bores are concentrically arranged around the central bore. This new setup introduces a completely new kinematic problem of the well-known clamping device. Namely, the collet segments move uniformly towards the centre as the tapered nut advances along the thread. But at the same time the segments move side-ward at a different pace. This means that the release of a clamping force over the lateral instruments will not happen simultaneously with the central instrument, which requires a special geometrical shape of the lateral bores in order to achieve an equal clamping force for all five instruments. To be brief, a special clamping head was developed which holds the electrode sleeves securely and allows smooth passage during incremental penetration of the microelectrodes. This significantly shortens the duration of operation and enables us not only to ensure a smoother course of the procedure but also more precise microelectrode placement.

Many different methods of performing DBS have been reported in the literature, but best practices are far from being established.^{22,23,33-35} Depending on future technological, surgical and anaesthetic improvements, the methods continue to evolve.

In order to optimize the outcome and to reduce the side effects, hardware (miniaturized stimulators, rechargeable batteries, and new electrode designs), software (new waveforms) and physiology (new targets) improvements are being tested and are expected.^{10,34,36} Even more, the first studies using intraparenchymal administration of drugs into the brain, namely glial cell line-derived neurotrophic factor (GDNF) for the treatment of PD, have been published.³⁷⁻³⁹

DBS has clearly become an established surgical treatment especially for movement disorders where several thousand patients have been successfully treated worldwide.^{11,40,41} Until recently, this treatment modality has been available only to few Slovenian patients who were treated abroad. Now, performing stereotactic DBS at our institution fosters medical expertise and clinical experience in the treatment of severe Parkinson disease patients in the Slovenian neurology and neurosurgery. Currently, DBS surgery should be considered when the quality of life is no longer acceptable, despite an optimal medical therapy administered by a neurologist. All six patients that have been operated on in Maribor are well and their quality of life has clearly improved. Perhaps the results would be even better if the patients were operated on at an earlier phase of the disease.

Acknowledgments

The costs of operations were covered by the University Clinical Centre Maribor. We would also like to thank Dr. Tomasz Stepień, Dr. Darko Chudy, Dr. Zoltan Chadaide and the staff from the Faculty of Mechanical Engineering Maribor for their valuable contribution during surgeries. The procedures couldn't have been performed without the excellent technical support of the radiological engineers from the Department of Radiology.

References

1. Sakas DE, Panourias IG, Simpson BA. An introduction to neural network surgery, a field of neuromodulation which is based on advances in neural networks science and digitised brain imaging. *Acta Neurochir Suppl* 2007; 97: 3–13.
2. Sironi VA. Origin and evolution of deep brain stimulation. *Front Integr Neurosci* 2011; 5:
3. Gale JT, Martinez-Rubio C, Sheth SA, Eskandar EN. Intra-operative behavioral tasks in awake humans undergoing deep brain stimulation surgery. *J Vis Exp* 2001; 46.
4. Perlmutter JS, Mink JW. Deep brain stimulation. *Annu Rev Neurosci* 2006; 29: 229–57.
5. Shah RS, Chang SY, Min HK, Cho ZH, Blaha CD, Lee KH. Deep brain stimulation: technology at the cutting edge. *J Clin Neurol* 2010; 6: 167–82.
6. McIntyre CC, Savasta M, Kerkerian-Le Goff L, Vitek JL. Uncovering the mechanism(s) of action of deep brain stimulation: activation, inhibition, or both. *Clin Neurophysiol* 2004; 155: 1239–48.
7. McIntyre CC, Savasta M, Walter BL, Vitek JL. How does deep brain stimulation work? Present understanding and future questions. *J Clin Neurophysiol* 2004; 21: 40–50.
8. Grill WM, Snyder AN, Miocinovic S. Deep brain stimulation creates an informational lesion of the stimulated nucleus. *Neuroreport* 2004; 15: 1137–40.
9. Johnson MD, Miocinovic S, McIntyre CC, Vitek JL. Mechanisms and targets of deep brain stimulation in movement disorders. *neurotherapeutics* 2008; 5: 294–308.
10. Andrews RJ. Neuromodulation: advances in the next five years. *Ann N Y Acad Sci* 2010 ; 1199: 204–11.
11. Hamani C, Neimat JS, Lozano AM. Deep brain stimulation and chemical neuromodulation : current use and perspectives for the future. *Acta Neurochir Suppl* 2007; 97: 127–33.
12. Kraus JK. Deep brain stimulation for dystonia in adults. Overview and developments. *Stereotact Funct Neurosurg* 2002; 78: 168–82.
13. Gross RE. Deep brain stimulation in the treatment of neurological and psychiatric disease. *Expert Rev Neurotherapeutics* 2004; 4: 465–78.
14. Theodore WH, Fisher R. Brain stimulation for epilepsy. *Acta Neurochir Suppl* 2007; 97: 261–72.
15. Franzini A, Leone M, Messina G, Cordella R, Marras C, Bussone G et al. Hypothalamic stimulation for cluster headache. In: Lozano AM, Gildenberg PL, Tasker RR, eds. *Textbook of stereotactic and functional neurosurgery*. 2nd ed. Berlin, Heidelberg: Springer-Verlag; 2009. p. 2517–24.
16. Nuttin BJ, Gabriels LA, Cosyns PR, Meyerson BA, Andriewitch S, Sunaert SG et al. Long-term electrical capsular stimulation in patients with obsessive-compulsive disorder. *Neurosurgery* 2003; 52: 1263–72.
17. Hamani C, Snyder B, Laxton A, Lozano A. Deep brain stimulation for depression. In: Lozano AM, Gildenberg PL, Tasker RR, eds. *Textbook of stereotactic and functional neurosurgery*. 2nd ed. Berlin, Heidelberg: Springer-Verlag; 2009. p. 2952–61.
18. Benabid AL, Pollak P, Louveau A, Henry S, de Rougemont J. Combined (thalamotomy and stimulation) stereotactic surgery of the VIM thalamic

- nucleus for bilateral Parkinson disease. *Appl Neurophysiol* 1987; 50: 344–6.
19. Blomstedt P, Hariz MI. Deep brain stimulation for movement disorders before DBS for movement disorders. *Parkinsonism Relat Disord* 2010 Aug; 16: 429–33.
 20. Cho ZH, Min HK, Oh SH, Han JY, Park CW, Chi JG et al. Direct visualization of deep brain stimulation targets in Parkinson disease with the use of 7-tesla magnetic resonance imaging. *J Neurosurg* 2010; 113: 639–47.
 21. Breit S, LeBas JF, Koudsie A, Schulz J, Benazzouz A, Pollak P et al. Targeting for the implantation of stimulation electrodes into the subthalamic nucleus: a comparative study of magnetic resonance imaging and ventriculography. *Neurosurgery* 2006; 58 1 Suppl: ONS83–95.
 22. Sakas DE, Kouyialis AT, Boviatsis EJ, Panourias IG, Stathis P, Tagaris G. Technical aspects and considerations of deep brain stimulation surgery for movement disorders. *Acta Neurochir Suppl* 2007; 97: 163–70.
 23. Deogaonkar M, Vitek JL. Globus pallidus stimulation for Parkinson's disease. In: Lozano AM, Gildenberg PL, Tasker RR, eds. *Textbook of stereotactic and functional neurosurgery*. 2nd ed. Berlin, Heidelberg: Springer-Verlag; 2009. p. 1577–602.
 24. Rezai AR, Kopell BH, Gross RE, Vitek JL, Sharan AD, Limousin P et al. Deep brain stimulation for Parkinson's disease: surgical issues. *Mov Disord* 2006; 21:S197–218.
 25. Strojnik T. Stimulacija globokih možganskih jeder. *ISIS* 2008; 17: 38–40.
 26. Drstvenšek I, Strojnik T. Naprava za mikro pozicioniranje instrumenta na stereotaktičnem sistemu. Ljubljana: Urad Republike Slovenije za intelektualno lastnino, 2011.
 27. Microdrive for use in stereotactic surgery. Available from: <http://www.wipo.int/patentscope/search/en/WO2011053259>.
 28. Foltynie T, Zrinzo L, Martinez-Torres I, Tripoliti E, Petersen E, Holl E et al. MRI-guided STN DBS in Parkinson's disease without microelectrode recording: efficacy and safety. *J Neurol Neurosurg Psychiatry* 2011; 82: 358–63.
 29. Bour LJ, Contarino MF, Foncke EMJ, de Bie RMA, van den Munckhof P, Speelman JD et al. Long term experience with intraoperative microrecording during DBS neurosurgery in STN and GPI. *Acta Neurochir* 2010; 152: 2069–77.
 30. McClelland S. A cost analysis of intraoperative microelectrode recording during subthalamic stimulation for Parkinson's disease. *Mov Disord* 2011; 26: 1422–7.
 31. Paek SH, Han JH, Lee JY, Kim C, Jeon BS, Kim DG. Electrode position determined by fused images of preoperative and postoperative magnetic resonance imaging and surgical outcome after subthalamic nucleus deep brain stimulation. *Neurosurgery* 2008; 63: 925–36.
 32. Chen SY, Lee CC, Lin SH, Hsin YL, Lee TW, Yen PS et al. Microelectrode recording can be a good adjunct in magnetic resonance image-directed subthalamic nucleus deep brain stimulation for parkinsonism. *Surg Neurol* 2006; 65: 253–60.
 33. Kramer DR, Halpern CH, Buonacore DL, McGill KR, Hurtig HI, Jaggi JL et al. Best surgical practices: a stepwise approach to the University of Pennsylvania deep brain stimulation protocol. *Neurosurg Focus* 2010; 29: E3
 34. Benabid AL, Mitrofanis J, Chabardes S, Seigneuret E, Torres N, Piallat B et al. Subthalamic nucleus stimulation for Parkinson's disease. In: Lozano AM, Gildenberg PL, Tasker RR, eds. *Textbook of stereotactic and functional neurosurgery*. 2nd ed. Berlin: Springer-Verlag; 2009. p. 1603–30.
 35. Wharen RE, Uitti RJ, Lucas JA. Thalamic stimulation for Parkinson's disease. In: Lozano AM, Gildenberg PL, Tasker RR, eds. *Textbook of stereotactic and functional neurosurgery*. 2nd ed. Berlin, Heidelberg: Springer-Verlag; 2009. p. 1631–47.
 36. Andrews RJ. Neuromodulation: advances in the next decade. *Ann N Y Acad Sci* 2010; 1199: 212–20.
 37. Gill SS, Patel NK, Hotton GR, O'Sullivan K, McCarter R, Bunnage M et al. Direct brain infusion of glial cell line-derived neurotrophic factor in Parkinson disease. *Nat Med* 2003; 9: 589–95.
 38. Patel NK, Gill SS. GDNF delivery for Parkinson's disease. *Acta Neurochir Suppl* 2007; 97: 135–54.
 39. Starr PA, Bankiewicz KS. Gene transfer for Parkinson's disease. In: Lozano AM, Gildenberg PL, Tasker RR, eds. *Textbook of stereotactic and functional neurosurgery*. 2nd ed. Berlin, Heidelberg: Springer-Verlag; 2009. p. 1718–29.
 40. About Medtronic DBS. Available from: <http://www.medtronicdbs.com/dystonia/about/index.htm>
 41. Anderson WS, Clatterbuck RE, Kobayashi K, Kim JH, Lenz FA. Lesions versus implanted stimulators in functional neurosurgery. In: Lozano AM, Gildenberg PL, Tasker RR, eds. *Textbook of stereotactic and functional neurosurgery*. 2nd ed. Berlin, Heidelberg: Springer-Verlag; 2009. p. 1349–57.