

## The collection of drainage samples for environmental analyses from active stream channels

Johnson, C.C., Flight, D.M.A, Ander, E.L., Lister, T.R., Breward, N., Fordyce, F.M.\* and Nice, S.E.

All British Geological Survey, Keyworth, Nottingham, NG12 5 GG,  
except \* British Geological Survey, Murchison House, West Mains Rd, Edinburgh,  
EH9 3LA

### ABSTRACT

The collection of drainage samples from active stream channels for geochemical mapping is now a well-established procedure that has readily been adapted for environmental studies. This account details the sampling methods used by the British Geological Survey in order to establish a geochemical baseline for the land area of Great Britain. This involves the collection of stream sediments, waters and panned heavy mineral concentrates for inorganic chemical analysis. The methods have been adapted and used in many different environments around the world. Detailed sampling protocols are given and sampling strategy, equipment and quality control are discussed.

### INTRODUCTION

Throughout human history rivers have played a vital role in human sustenance, settlement and transportation and of all the earth's systems it is in the drainage environment where man probably has had the greatest impact. From a geological perspective the flow of water is an important process in the shaping of the earth's surface and early civilisations knew how to use drainage channels to trace valuable metals and minerals dispersed in alluvium back to their source. Theophrastus (300 BC) describes how the ancient Greeks searched for ore deposits by tracing detrital anomalies in rivers (Caley and Richards, 1956) and copper for pre-Bronze Age cultures was located using alluvial dispersion trains (Wertime, 1973). The art of panning detrital material for precious minerals both from active and defunct drainage channels is a long established skill and an activity that supplements the income of farmers in many parts of the developing world.

The collection and chemical analysis of various sample media from the drainage system is a well-established exploration tool having its origins in the Soviet Union (Fersman, 1939) and subsequently applied elsewhere, for example Lovering et al. (1950) and Hawkes and Bloom (1955). Although the majority of early surveys were concerned with mineral exploration there are examples of regional geochemical mapping based on drainage samples being applied to environmental problems (e.g. Thornton and Webb, 1979, Plant and Moore, 1979). The anthropogenic effect on drainage sediment geochemistry was reviewed by Cooper and Thornton (1994).

Webb and Howarth (1979) wrote: "*Although it was apparent more than 20 years ago that geochemical atlases would eventually become a national cartographic requirement, regional geochemical mapping is still in the experimental stage. This trend is now evident in activity in a number of countries. The methods being employed, however, are so diverse that there is an urgent need for international collaboration aimed at securing data that are as mutually compatible as possible.*". This need was finally addressed by the International Geological Correlation Programme (IGCP) Project 259 "A global geochemical database for environmental and resource management" (Darnley et al., 1995). This states that wherever the landscape permits, drainage samples, specifically stream sediments, have been the preferred sampling medium for reconnaissance exploration surveys.

Current output of publications on environmental applications of drainage surveys is now far greater than for exploration investigations (e.g. Lee et al., 2003; Gonçalves et al., 2004; Schreck et al., 2005; and Ettler et al., 2006). There is also a greater emphasis on multi-purpose environmental baseline data generated from multi-media sampling as demonstrated by the Geochemical Atlas of Europe (Salminen et al., 2005) and the environment and resource evaluation of the Tellus geochemical mapping project in Northern Ireland (Young and Smyth, 2005).

A variety of sample media can be classified as drainage samples. These include stream, lake, overbank and floodplain sediments; stream and lake water; suspended/colloidal sediment in streams or lakes; and precipitates or coatings on stones and boulders from the stream bed. The use of drainage sample media in geochemistry was comprehensively reviewed by Hale and Plant (1994). The account presented here is specifically concerned with procedures for collecting samples from the active drainage channel (stream sediment, suspended sediment, stream water and panned heavy mineral concentrates) and lake, overbank and floodplain samples are not discussed further. The procedural section in this account is based on the British Geological Survey (BGS) G-BASE (Geochemical Baseline Survey of the Environment) Project. This is a long established programme to produce geochemical maps of inorganic elements of the United Kingdom land area based mainly on high density sampling of stream sediments (Johnson et al., 2005).

## **DRAINAGE BASINS**

The study of streams is part of the scientific discipline known as hydrology. Some of the terminology associated with the drainage system is summarised in Table 1. A stream can be defined as being a body of water confined by the land surface as its base (known as the stream “bed”) and laterally by banks. It is a term often used to cover all naturally flowing water; “river” is a term generally applied to a large natural stream. Stream water may or may not flow all year but the channel or course along which it flows is a feature that, with or without water, can be sampled throughout the year. Intermittent streams, which flow for only part of the year, are usually found in regions where there is a marked rainfall contrast between seasons or seasonal temperature variations result in the melting of ice or snow. An intermittent stream in an arid area is also sometimes referred to by the Arabic term “wadi”. These streams are often associated with hazardous events such as flash floods where sudden heavy rain or rapidly melting snow upstream can result in a torrent of debris and water further downstream in areas where there has been no recent precipitation. These events cause significant redistribution of detrital material and are a very important consideration in the health and safety of sampling teams. Streams that form only for a short period during times of precipitation are referred to as ephemeral streams.

Streams are part of a drainage basin system which has inputs, flows, stores and outputs of both water and detrital material. The drainage basin concept is illustrated in Figure 1 which shows basins defined by a topographic feature known as the watershed. Drainage basins, sometimes also referred to as drainage catchments, can be broken down into smaller or larger “nested” basins that can be defined in terms of the stream rank or order. A hierarchy of streams can be set up, the more objective and straightforward system is known as the Strahler stream order (Strahler, 1957) which is also illustrated in Figure 1.

High order drainage basins often define administrative boundaries for the management of resources e.g. the Hydrometric Areas of the United Kingdom (Institute of Hydrology, 2003). In Earth and Environmental Sciences the drainage basin is an important means of defining an area equivalent in many respects to post or zip codes that have such widespread application in Geographical Information Systems (GIS). The drainage basin area is not only important as a means of delineating a data set within a GIS but it is also fundamental in the sampling and data interpretation processes. In remote under-developed areas rivers generally are the only means of ground access into an area so sampling and mapping is very much based along the river system. In areas of high relief the drainage channels represent the mostly likely place to find rock outcrops as a result of downward erosion by the stream system. The BGS mapping of northern Sumatra, Indonesia (1975-1980) was entirely based on drainage basin areas and mapping teams were assigned basins to sample during seasonal field campaigns. Drainage basin reports formed the basis for later regional compilations.

Interpreting results from a drainage sample requires an understanding of its derivation and the behaviour of chemical elements in the drainage environment. A drainage sample is a composite of material derived upstream of the sampling site limited by the watershed boundary. In this way a sample can be collected that is representative of a much larger area than just the point represented by the sample site (its true representativity is discussed later in this account). The area covered depends on the order of the drainage basin with first order basin generally covering areas of <10 km<sup>2</sup> and third and fourth order basins areas of >100 km<sup>2</sup> though this will very much depend on the geomorphology of the landscape. The drainage sampling described here is based on the sampling of low-order streams, generally 1<sup>st</sup> to 3<sup>rd</sup> order so the sample represents a relatively small area and is not a generalised composite of too many drainage basins.

## **DRAINAGE SAMPLING**

Drainage sampling has a significant advantage over other types of media because a wide variety of different sample media can be collected from a single site. This represents a very economical and effective way of generating geochemical information and such a multi-media survey has great value in interpreting the distribution and behaviour of determinands in the surface environment. For example, the distribution of arsenic in stream sediments and stream waters over Mesozoic sedimentary ironstone outcrops in eastern England show the benefits of being able to compare the geochemistry of different sample media in a regional geochemical survey (Figure 2). In this case, very high levels of arsenic are present in stream sediments over the ironstone outcrops, but the very low mobility of arsenic when bound to sedimentary iron oxides is illustrated by the absence of corresponding elevated arsenic levels in the stream waters.

From a logistical point of view the ability to collect a single sample that represents a large area greatly reduces the number of samples needing to be collected. The fact that one can collect drainage samples from adjacent tributaries from sites that may only be tens of metres apart greatly reduces the amount of time spent walking between sites. Anyone that has been involved in sampling will testify to the time and effort saved by not having to walk up hills and mountains to collect samples from near watersheds as the stream effectively brings the material down the valleys to the sampler.

Although there are standard procedures for the collection of environmental samples for very specific purposes (e.g. guidance in collecting bottom sediments in association with water quality, ISO 5667-12:1995) there are no nationally or internationally prescribed standards for the collection of drainage samples. The recommendations of Darnley et al. (1995) provide a top level of guidance to those planning sampling programmes where, at project level, there should always be detailed instructions on how samples should be collected, as shown for example in Salminen et al. (1998) (FOREGS project geochemical mapping field manual) and Johnson (2005) (BGS G-BASE field procedures manual). Such detailed documentation is essential to give quality assurance to results and provide necessary information for the data users to establish whether it is fit for its intended purpose. In any environmental survey the sampling procedure used should be recorded as a coded field within the resulting database. The G-BASE project now includes a “sampling protocol” code as part of the field form completed at each sampling site (Figure 3).

## **SAMPLING STRATEGY**

The broad range of procedural options available to an environmental scientist planning a sampling project using drainage samples is discussed in detail by Hale (1994). Although this is aimed at the exploration geochemist, the sample campaign planning decisions faced by environmental scientists are just the same. The sampling plan must firstly take into account the stakeholders of the project, that is organisations or individuals that have an investment or interest in the project and will have a planned use for the data. In this sense planning the project strategy needs to work backwards from the point of deciding what products need to be delivered and what they have to be used for. At this point it can be decided which sampling media can best meet the objectives of the user. The environmental scientist or geochemist needs to communicate scientific output in terms that are understandable to stakeholders that may not understand the science but need information to satisfy their requirement. For example, determining if stream water concentrations of heavy metals exceed statutory levels.

Whether or not objectives of the stakeholders can be achieved greatly depends on our knowledge as to the usefulness of the various sampling media and the uncertainty that can be associated with a set of results when delivering an objective. This requires the skills and experience of a geochemist who must be able to justify decisions made during the planning phase. The choice of sample media, and the fraction of that sample media to be used, will determine what element concentrations and distributions will be best defined. Analytical methodologies employed will decide whether element concentrations reflect total levels or merely a partial extraction. This is particularly important in environmental health studies where the availability of essential or toxic elements rather than an understanding of the total concentration determine the level of risk. Multi-media surveys with a wide range of analytical methods employed are a good way of satisfying a wide range of stakeholders (an example of this is the Tellus Project in Northern Ireland, Young and Smyth, 2005).

However, it is rare that surveys have the luxury of a budget to achieve all that is desirable and often compromises have to be made in the sampling and analytical strategy. An example of this could be in the fraction size of sediment collected. Fine sediment may be good at discriminating chemical anomalies for elements diffused by hydromorphic dispersion but it may miss coarser grains transported predominantly by mechanical dispersion and not transported in the lighter and finer sediment fractions. With industrial slag, for example, coarser mineral grains that do not readily breakdown would be missed if only very fine sediment was collected. It is in such instances where the multi-media opportunities afforded at a single drainage site make drainage sampling an attractive strategy, especially as a first-stage environmental geochemical sampling tool.

In addition to being able to satisfy the stakeholders objectives within an available budget there are logistical constraints to any project. These would include ease of access to a sampling area and climatic conditions (particularly in relation to seasonal variations). For the latter, consideration of seasonal stream flow in drainage catchments is an important criteria both from a scientific and safety view point. Furthermore climate may also be associated with ease of access with heavy rain or snow making roads and tracks impassable and river crossings difficult. The ease of access more often than not relates to one of the biggest expenditures in the sampling budget namely the transport of personnel and samples to and from sample sites.

In inaccessible areas a choice has to be made between high cost helicopters or collecting on foot. The latter may only require modest expenditure but over a considerably longer period of time, so overall expenditure could be the same as a helicopter-borne survey. In a commercial project time and money will be of prime concern. For national surveys where there is a large component of institutional building and involvement of local people to be considered, maximising the benefit to the local community by carrying out a ground based rather than helicopter survey will be a more acceptable strategy.

Questions of sampling strategy are reviewed well elsewhere (see Darnley et al., 1995) and include discussion of decisions to be made on the optimum fraction size of sediment to be employed, sampling density, and methods of chemical analysis. A knowledge of the behaviour of chemical elements in different environments and an appreciation of element associations (see Table 2 and Table 3) greatly helps in the planning and interpretative phases of the project. If it is determined that certain elements are of great importance to the data users (e.g. mercury) then sampling strategy may have to be modified to collect the sample with out compromising the results for the most important elements.

Once decisions have been made it is always a good strategy to carry out an orientation survey to test out sampling plans. Examples of such orientations can be found described in Plant (1971) (drainage sampling in Great Britain); British Geological Survey (1999a) (drainage sampling in the Atlas Mountains of Morocco) and Ranasinghe et al. (2002) (drainage sampling in Sri Lanka).

## **PROCEDURES**

The following procedures are derived from the G-BASE field procedures manual (Johnson, 2005). They are presented here as a generic template for multi-purpose drainage sampling and are methods that have been developed and refined over a period of more than thirty years. The basic procedures have changed little since reported by Plant and Moore (1979) and have been adapted and applied to many major geochemical mapping projects around the world spanning many climatic zones (e.g. Sumatra, Indonesia - Stephenson et al., 1982 and Muchsin et al., 1997; Ecuador - Williams et al., 2000; and Morocco - Johnson et al., 2001.) Such adaptations to different climatic zones and stakeholder requirements are discussed at the end of this section.

### ***Generic sampling considerations***

There are some fundamental issues that need to be addressed in order to understand important steps incorporated into the procedures described in the following subsections.

Reliability of sampling teams. The quality of an environmental survey is only as good as the most poorly controlled part of a survey and this will frequently be the sampling. Procedures must be in place to ensure samplers are reliable and are strictly following protocols, particularly when the work involves the use of many different samplers. They need to be motivated and understand why they are collecting

the samples in the prescribed way. Good team leaders are essential in this process. Rotation of individuals in different sampling pairs is important to maintain a check on procedural discrepancies. The more widespread use of GPS has greatly improved the reliability in sample site positioning and this gives a confirmation that samplers have actually visited sites as scheduled.

Avoiding contamination. Environmental studies involve determining trace levels of elements or in the case of water samples ultra-trace levels and procedures have to be designed so as to avoid introducing contamination through the sampling tools, sample handling and the storage containers. Any orientation studies should be designed to include steps to test for contamination such as subjecting samples of pure silica sand or de-ionised water to all the steps in the sampling procedure. In the following subsections trademarked products such as Kraft™ paper bags, polyethylene Nalgene™ water containers, Millex™ filter papers or Swinex™ filter holders are referred to. These are items which the G-BASE project has found suitable for its survey, other surveys may use other trademarked products – the important point is that every piece of equipment used in the sampling must be investigated as a potential source of contamination.

### ***Sampling team and responsibilities***

Sampling is a team effort best led by personnel that have had practical experience of sampling themselves. The organisation of a typical sampling team is shown in Figure 4 and consists of a Project Manager, a Field Team Leader and Assistant and a number of sampling pairs. The Project Manager is responsible overall for the sampling strategy and logistics, the teams health and safety, managing the samplers' contracts, sampling budget and delivering samples to the laboratory for analysis. As part of the quality assurance the Project Manager should have regular inspection of the field work. The Field Team Leader is responsible for the day-to-day operations of the sampling team including allocation of daily sampling quotas and checking samples and field forms at the end of each sampling period (usually daily). The leader will need to be an experienced sampler and a good team worker in order to maintain the motivation and confidence of the samplers. The leader's assistant will be less experienced in managing a team but someone that bridges the gap between Team Leader and samplers, with an expectation that they can both share the responsibilities of the leader as well as being actively involved in the sampling.

The key personnel are the samplers who should always work in pairs but not always with the same partner. This satisfies health and safety requirements and by varying the make up of each pair ensures a consistent implementation of sampling procedures throughout the team. BGS uses samplers that are undergraduates or recent graduates of earth or environmental sciences seeking to gain practical experience in sampling. They generally do not earn a wage but are given a daily subsistence allowance and the knowledge that their work experience is an invaluable addition to their *curriculum vitae*. This model of employment has been used by the G-BASE project for more than 35 years and several BGS geochemical mapping projects internationally (e.g. Morocco and Madagascar). When working in more remote or difficult areas the sampling pair may consist of a graduate plus a labourer. If sampling areas of special difficulty, urban environments and remote jungle being examples at two extremes, samplers may need to be accompanied by personnel with specialist knowledge of the area. For example, G-BASE whilst carrying out drainage sampling in the Glasgow area of Scotland, sampling pairs were assisted by municipal workers.

Any sampling campaign will usually commence with a training day for the samplers so they have a good knowledge of the sampling procedures and how to complete field forms that record information about the sampling site and the sample itself. Ideally, at the commencement of a sampling campaign the sampling team will have a number of experienced samplers who can be paired off with the inexperienced ones in the first few days of the sampling. The number of sampling teams and pairs depends very much on the logistics of the operation. Use of too many samplers may result in collecting samples faster than they can be collated or analysed and will, if vehicles are being used, require larger or more vehicles for transport. Too few samplers will lead to unacceptably slow sampling rates and also results in overdue dependence on a small number of samplers. It is also good practice to ensure team leaders are regularly brought together for sampling training to ensure procedures are being correctly followed with no deviations.

All personnel should be asked to contribute to a field campaign report at the end of sampling. In this way any deviations from standard procedure can be documented and suggested improvements to the

methodology can be recommended. A review of these recommendations on an annual basis leads to improvements in procedures that can be included in sampling protocol revisions.

### ***Field sampling equipment***

A list of equipment required for drainage sampling is given in Table 4. A great advantage of geochemical methods over geophysical methods is that the field equipment is relatively cheap and generally readily available. The equipment can be divided into three parts; there are the items necessary for (i) collecting the sample; (ii) describing and marking the sampling site; and (iii) carrying and transporting the equipment and samples. Such equipment can be adapted to suit the aims and objectives of a survey particularly where local alternatives may be readily more available (see discussion).

### ***Sampling Procedures***

The mantra of sampling is to “avoid introducing contamination” during the sampling process. Samplers should not wear hand jewellery and all sampling equipment must be free of contaminants and cleaned thoroughly between sample sites. Water sample analysis, in particular, involves determinations to very low concentrations and care should be taken to wash hands in the stream water first to remove any sweat or lotions (such as sun cream), and handling sample bottles must be done in such a way that the inside of bottles or lids are not touched by the hand.

### ***Site selection***

Sites will have been pre-plotted on a topographic map and samplers should make their way to the designated site. However, the precise sampling site requires the samplers to understand what constitutes a good sampling site. This will to some extent depend on the nature of the survey. For the G-BASE baseline mapping the instructions are:

- Find a site with flowing water and a good supply of sediment in the stream bed
- Always sample upstream of any tracks and roads
- Avoid places where there is obvious bank-fall or soil material in the stream
- Avoid sampling where animals congregate in the stream to drink
- Sample above any obvious contamination to the natural system (e.g. a land drain outlet, mine waste or a dumped car)

One sampler should walk 50-100 m upstream (along the bank) of the intended site to check for any localised contamination, prior to initiating sample collection. Sometimes it is impossible to fulfil all the above criteria. For example during dry periods the stream may have no water or the entire length of the stream may have been dredged and straightened by agricultural activity. If no alternative is available, less suitable sites will have to be used with adequate comments and descriptions recorded on the field form. As the sampling methodology is based on low order streams the depth of water should generally be no more than waist deep.

The selection of the exact spot for sampling is a skill that develops with experience. Figure 6 shows a typical cross section of a stream channel for a 1<sup>st</sup> or 2<sup>nd</sup> order stream and shows a typical site where sediment should be collected. Samplers should seek to sample typical flow regimes rather than sites which favour depositional sorting, e.g. centre of streams away from banks and not behind obstructions. In surveys where heavy or larger detrital minerals are being sought, samples should be taken from the higher energy part of the channel (i.e. where the water is flowing fastest) or from downstream of boulders where an obstruction to stream flow has resulted in the deposition of the heaviest part of the rivers mechanically transported load.

On arrival at site, samples should be collected in the order of stream water, stream sediment and panned heavy mineral concentrate. A flow chart of procedures is shown in Figure 7 which demonstrates the team effort of a sampling pair to efficiently sample a site in a strictly prescribed order. Time spent at each site will vary according to the experience of the samplers and the ease of collecting and sieving fine sediment. On average a drainage site should take 30 - 40 minutes to sample.

The following procedures describe the specific way in which the G-BASE project collects drainage samples.

### *Collecting a stream water*

1. Sampler 1 unpacks all the sampling equipment. Sampler 2 labels the water sample bottles (and the sediment and panned concentrate bags). Four bottles are used for various analytical methods. The pre-allocated site number (taken from the field card) is written on the sample containers, using the black permanent ink marker. The site number becomes the sample number by including a sample type code as a suffix, in the case of waters this is “W”. The number should be written along the side, starting from the cap end. The following sample-type codes must also be written on each container: **F/UA** – filtered unacidified (30 ml Nalgene™ bottle); **F/A** – filtered and acidified (60 ml Nalgene™ bottle); **pH** (30 ml polyethylene bottle); and **Alkalinity/Conductivity** – (250 ml Nalgene™ polyethylene bottle). Sampler 2 commences by collecting the filtered samples first.
2. Water samples are collected the mid-stream flow, on the upstream side of the sediment sample location. Sampler 2 should stand facing upstream and sediment must not be disturbed. The filter should be removed from the self-seal bag without contaminating the connector - it should only be handled along its sides. Flush the syringe three times with stream water before connecting a clean Millex™ filter; filters should never be used at more than one site. Flush the filter with 5-10 ml of stream water. Carefully rinse the Nalgene™ bottles and caps with filtered stream water (minimum 10 ml). Special care must be taken to ensure that the sample containers and lids remain uncontaminated; the inside of lids and containers should not be handled and must not be allowed to come into contact with hands, soil, vegetation, or unfiltered water. If they need to be put down while open they must be placed on a clean polythene bag. Fill the 60 ml bottle to the neck and completely fill the 30 ml bottle. Apply caps tightly, ensuring that no leakage occurs. Place the filtered samples into a clean 15 x 43 cm polythene bag tied with a knot then transported inside a self-seal polythene bag. If the bottle, cap or filter are dropped, or otherwise contaminated, a replacement must be used and the process re-started. In situations where filtration is difficult (i.e. very turbid waters), the F/A sample should be collected first. An additional 250 ml Nalgene™ bottle may be filled with unfiltered water, marked with the sample number and the relevant sample type(s), and taken to the field base for filtration. It is important to try and filter the sample for trace element analysis at site, as an unquantifiable rate of cation adsorption onto container walls and suspended sediment may occur from the larger bottle before filtration. In areas where the water tends to have a particularly high proportion of suspended material 'pre-filters' are included in the sampling kit. This should only be done where absolutely necessary in order to avoid confusion and incorrect filtration; the sample teams should be reminded of the procedure to use. The pre-filtering process uses a coarser 25 µm pre-filter mounted in a Swinnex™ filter holder. The sample is first passed through the coarse pre-filter then through the 0.45 µm Millex™ disposable filter.
3. Sampler 2 collects the pH and conductivity/alkalinity samples immediately after the filtered water samples. Like the filtered samples, they should be collected from the mid-stream flow, on the upstream side of the sampler. Thoroughly rinse the sample containers and caps with stream water **three times**. Submerge the containers in the stream to fill; then seal underwater, ensuring that all air has been expelled. Place the unfiltered samples into a clean, self-seal polythene bag along with the knotted bag containing the filtered water samples.
4. Sampler 2, in order to complete the water colour and suspended solids part of the field form, needs to determine these by filling a polythene bag (15 x 43 cm) with stream water and holding it up against the sky as a background to observe the water colour and transparency.

The “dirty filter” with the >0.45 µm suspended sediment can be used as an additional sample media from this site and can be bagged and labelled for future analysis. Note that the F/A samples are acidified using Aristar-grade concentrated nitric acid when samples are returned to the field base each day. This is because it is undesirable to have the samplers carrying concentrated acid while in the field. Samples are acidified to 1% v/v (i.e. 0.6 ml conc. acid per 60 ml of sample). An additional precaution against contamination, one that is not employed by G-BASE, is the use of disposable vinyl gloves (Salminen et al., 1998). Many surveys collecting stream waters will routinely determine pH, alkalinity and conductivity at site. The G-BASE project does such measurements back at the field base always within 24 hours of sample collection. This gives better reproducibility than on site field measurements.

## *Collecting stream sediment*

1. Sampler 1 downstream of the water sampling will wash the trenching tool (shovel), sieve nest, both pans, the plastic funnel and both sets of thick black protective rubber gloves with stream water. The sieve nest (Figure 5) is assembled on top of the glass-fibre pan, in a stable position, as close to the sediment collection point as possible. The collection pan and sieves must be clean and free from any particulate matter prior to commencement of sampling.
2. The sediment collection position should be an active area of the stream bed (Figure 6), and should ideally be centrally placed in the stream, to minimise contamination from any bank fall material. Sampler 2 firstly, removes the uppermost (10 to 20 cm) heavily oxidised sediment with the shovel and then loads the top sieve with coarsely sorted sediment from beneath the oxidised layer, taking care to drain off excess water and remove any large clasts before placing the material into the top sieve. If the sediment lies on a base of peat or clayey till, take care to ensure that the sediment is sampled without digging into the underlying fixed material. It will normally be necessary to dig 15 - 25 kg (wet weight ) of material to provide a sufficient final sample weight. If there is abundant sediment in the stream bed this can normally be achieved from a single “hole”, if sediment is scarce then several holes may need to be dug over a length of the stream bed of no more than 5 m.
3. Sampler 1 as loading the sieve proceeds, rubs the stream sediment through the top sieve, providing sufficient (normally 2-3 kg) <2000 µm material in the lower sieve to produce adequate <150 µm material. During this process look out for any contaminant material in the sediment, which should be removed from the sieve and the details noted on the field data card. Before the upper sieve becomes too full and heavy it should be removed and shaken to allow more <2000 µm material to fall through into the bottom sieve. It is very important to make sure the outside of the upper sieve is free of any sediment otherwise coarse grains could fall into the fine sediment when shaking. The upper sieve material can then be discarded and this material is often worth observing for stream clast lithologies, which are noted on the field data card. Several cycles of filling, rubbing, shaking and discarding of the top sieve material may be required to provide enough material in the lower sieve. This is dependant on the physical nature of the stream sediment material.
4. Once there is sufficient material in the lower sieve Sampler 1 should mix around and rub the < 150 µm to help material to pass through into the collecting pan. If the lower sieve material is very dry and sandy it is often necessary to sprinkle a small amount of water into the lower sieve while mixing and rubbing the material. **Care must be taken not to flood the collecting pan with too much water otherwise there is a danger of fine material being washed away.**
5. When the lower sieve material has been well mixed and rubbed through, Sampler 1 rinses the rubber gloves and then uses the funnel to rinse any particulate material off of the top rim and outer sides of the lower sieve, ensuring that the volume of water which goes into the sieve is kept to a minimum. The lower sieve should then be picked up carefully, without disturbing the collecting pan, and gently shaken to allow additional <150 µm material to fall through into the collecting pan. If there appears to be insufficient material in the collecting pan, the lower sieve may be replaced and the material re-mixed and rubbed while sprinkling with a small volume of water (<100 ml). The gloves and sieve top and outer sides should then be re-rinsed and the sieve carefully lifted and shaken as before. Take particular care at this stage to avoid biasing the sediment sample by incorporating oversize material. Once there is enough sediment in the collecting pan, remove the lower sieve and retain the <2000 µm material which it contains. **Leave the pan containing the <150 µm sample undisturbed for about 20 minutes to allow the settling out of suspended material.**
6. While Sampler 2 is panning (see below) Sampler 1 completes the field form (Figure 3) with site and sample descriptions.
7. When the fine material has settled in the collecting pan, Sampler 1 decants the fine sediment slurry into a sample bag. Sampler 1 puts on a pair of rubber gloves, cleans them in the stream water, then slowly decants excess water from the surface of the sediment collecting pan. The sediment sample is then homogenised by firmly, but carefully, shaking the pan to mix the dense, particulate material with the fine colloidal fraction. This is important as if there is an excess of material, any portion discarded must be the same as the portion which is retained (final sample volume should be 200–250 ml). At this stage, the sediment details (colour, clay, and organic content, the latter two estimated as high/medium/low) should be noted. Next, Sampler 1 thoroughly rinses clean the polypropylene funnel with stream water then transfer



the sample, via the funnel, to the appropriate, numbered Kraft™ paper bag 10 x 20 cm (4 x 8 in). See the water sampling procedure, step 1, for sample number allocation – for stream sediments the G-BASE project uses the sample type code “C”. The Kraft™ bag is sealed by folding the tab over three times and bending the wire fixings over the ends of the envelope. Place the sealed Kraft™ bag in a 15 x 43 cm (6 x 17 in) polythene bag and tie a loose knot in the polythene bag to prevent loss or contamination during transport. The sealed bags are placed into a plastic box, and then into a rucksack, taking care to ensure that the sample bag is upright.

### ***Collecting panned concentrate***

1. Sampler 2 commences collecting the panned concentrate while the sediment is settling in the collecting pan. The <2000 µm material retained from the sediment collection process is tipped into the wooden Malaysian “dulang” style pan, using water from the funnel to wash all the material from the sieve.
2. Further wet <2000 µm sediment from as deep as possible within the stream bed, using the top sieve placed directly on the wooden pan. Copious amounts of water may be used to aid sieving at this stage. Once the wooden pan is almost full of <2000 µm material the panned heavy mineral concentrate is then collected using the following three stages;
  - (a) Removal of clay and organic material which binds grains together by repeated washing and stirring of the material in the pan. The pan should not be submerged during this procedure but clean water should be continually added and dirty water poured out. Once the grains feel well separated and the water being poured out looks relatively clean, proceed to stage (b).
  - (b) Formation of heavy-mineral bed by vigorous shaking of pan with ample water for a minimum duration of two minutes. This allows density separation in the pan material and is extremely important before proceeding to stage (c).
  - (c) Selective removal of the less dense fraction by circulating the pan on the surface of the water in an elliptical fashion to yield 20 to 40 g of heavy mineral (density greater than 2.9 g/cm<sup>3</sup>) concentrate. This process is best demonstrated by an experienced sampler and it is important during stage (c) to regularly stop circulating and re-shake the material to maintain density separation.
3. Sampler 2 inspects the final concentrate with a hand lens and notes the presence and relative abundance of heavy minerals on the field form. The funnel is used to transfer the concentrate material to a numbered, 8 x 13 cm (3” x 5”) Kraft™ sample bag using sufficient water to ensure complete recovery of all grains. The sample type code for a panned concentrate is “P”.

### ***Collecting duplicate samples***

One sample in every hundred samples collected by the G-BASE project is a duplicate sample. A predefined sample and duplicate site number is allocated to samplers who must collect a duplicate stream sediment and stream water sample from a single site. A duplicated panned sample is not generally collected because such samples are not routinely submitted for chemical analysis. It is stipulated that a stream sediment and water duplicate should be collected within 25 m of the original sample.

### ***Dry Sites***

During periods of prolonged dryness small first-order streams in the UK may dry out so collecting a water sample is not possible. However, the stream sediment and panned concentrate can still be sampled. The 2000 µm sieve can be used to collect approximately 5 kg of material and stored in labelled self-seal polythene bags. If the material is predominantly clay, less material needs to be collected and if the sample is still moist then dry sieving will not be appropriate and larger stones and fragments are removed by hand. The bulk sample can be carried to the next wet site or base camp for subsequent wet-sieving and panning.

Before leaving the site, as was performed on arrival, all equipment should be thoroughly rinsed to remove traces of particulate material to avoid between site contamination. The field form should be checked to ensure that all observations have been noted. If any field observations are not applicable at a site, e.g. there is no contamination, the relevant box should be struck through so it is clear that the observation was investigated but there was nothing to record. Finally, on departure, the site should be

clear with all of the samples and field equipment packed in the rucksacks ready to be taken to the next site.

On return to field base stream sediment samples require careful handling. At the end of each sampling day the field team leader and assistant will go through a procedure of checking samples in by marking checklists confirming the sample numbers are readable and correct. The paper sample bags should be hung up to air dry. The Kraft™ paper sample bags will allow water to seep out but not the fine sediment. However, the samples should not be dried until they are rock hard, the paper bag should be dry and the sediment having a plastic consistency. Wet paper bags left unattended will rot in a very short time and samples will be lost.

### ***Control Samples***

An important part of the sampling methodology relates to the use of control samples in order that the data can be quality controlled and quality assured (see Johnson et al., this volume). While it is only duplicates that are created during the sampling process, these, along with replicates, blanks (for waters) and secondary reference materials need to be assigned sample numbers so they are included as part of the routine sample submission and are “blind” to the analyst. Duplicate samples are collected from a single site according to the procedures described earlier. A pair of duplicate samples (i.e. a normal sample and an additional sample collected at the same site) help to define the within site sampling uncertainty. Each sample of the duplicate pair can be split in the laboratory (again following a strictly defined procedure) to give replicates. Replicates help to define any laboratory or within sample uncertainty. For waters a blank sample is created from de-ionised water and acidified in the same manner as normal water samples. This acts as a check to see if any contaminants are added during the process of sample acidification and sample storage. Nested ANOVA analysis of the duplicate and replicate samples (Sinclair, 1983) can be used to assign the source of variability between sample sites, within sites and between sites. The point of such an analysis is to demonstrate the validity of the sampling strategy. It is obviously highly desirable to have the maximum variance attributed to between sites variability. If the combined sampling and analytical variance (i.e. within site and within sample variance) exceeds 10% then there are issues with the sampling strategy that need to be explained. A common cause of a high analytical variance is when element results are at or near the lower limit of detection.

The G-BASE project collects samples in random number order (Plant, 1973) as this helps to identify any correctable systematic errors introduced during sample preparation and analysis, processes in which the samples are handled in numeric order. For every block of one hundred numbers, five numbers are reserved for control samples so when they are submitted within a batch of samples they are “blind” to the analyst. The control samples inserted are one duplicate sample, two replicate samples and two secondary reference materials (SRM) used to monitor accuracy and precision as well as to level data between different field campaigns (see Johnson et al., this volume). Including the original sample of the duplicate pair this means 8% of samples submitted are control samples, a point not to be over looked in setting the budget for analyses.

These blind control samples are in addition to any primary reference materials (PRM) that the laboratory may also analyse. For the G-BASE project the BGS laboratories usually insert a PRM at the beginning and end of each batch of five hundred samples. As G-BASE generally collects and analyses 2000-3000 samples each field campaign eight percent of the samples is more than adequate to carry out quality control procedures. However, if sample number are less than 500 it is recommended that the number of duplicates and replicates per hundred samples should be doubled.

### ***Health and Safety***

Health and safety considerations should be an important part of planning a drainage sampling campaign and instruction on health and safety issues must be given to sampling teams before they commence work. Apart from the obvious duty of care a project manager has for their sampling team and the samplers have for each other, serious accidents to personnel can seriously disrupt or terminate a sampling program. It is surprising how often samplers or labourers employed to collect and carry samples, often involving crossing or working near deep water, have never been asked such a

fundamental question as to whether they could swim. A risk assessment should always be part of a sampling plan whether or not it is a statutory requirement of the country of work. A summary of the G-BASE project health and safety concerns and mitigating actions are given in Table 5. In urban areas the health and safety aspects of working in heavily polluted culverted streams makes it essential that the field geochemists have the assistance and involvement of municipal authorities during the sampling.

## **DISCUSSION**

### ***Sampling equipment***

For collecting drainage samples the fundamental piece of equipment is the sieve set and this is shown diagrammatically in Figure 5. This is the wooden sieve set with nylon mesh that has been used throughout the history of BGS G-BASE project and has a proven history of robustness. The use of a nylon sieve mesh and wooden sieve relate to a desire to minimise any contamination that may be introduced through sampling equipment. Plastic polymer sieve sets are currently undergoing trials on several BGS projects. Steel equipment can introduce elements such as V, Cr, Mn and W and plastics can contain high levels of Cd and Sb. Similarly sample bags and water containers have to be free of sources of contamination. Water containers can be particularly problematical if they for example contain metal foil-inserts in the cap or are made of plastic from which trace elements can readily be leached by the acidic water sample.

The sieve set can readily be adapted to suit the working environment. For the BGS reconnaissance geochemical mapping in the tropical climate of Sumatra (at a sampling density of approximately one sediment per 15 km<sup>2</sup> - Stephenson et al., 1982, and Muchsin et al., 1997) the 2000 µm mesh sieve was used but not the 150 µm sieve - the fine sediment sieving was carried out in the laboratory. In the semi-arid Anti-Atlas Mountains (geochemical exploration with drainage sediments at one sample per km<sup>2</sup>) the sieve sets were reduced in diameter to 25 cm to lighten the load samplers had to carry in the hot climate. These were equally efficient at sieving dry sediment. Orientation work in this Moroccan environment, where the streams were predominantly dry for more than 10 months in the year, showed that a coarser stream sediment fraction was more suitable for defining anomalies associated with mineralization (British Geological Survey, 1999a). BGS's ongoing geochemical sampling in Madagascar has not used sieve sets and is instead using just flat wooden framed sieve screens sieving directly into a collecting pan. This greatly reduces the amount of equipment samplers have to carry but will increase sampling error due to the greater risk of unsieved material entering the pan. The G-BASE project has a preference for wet sieving as fine particles are more likely to be disaggregated than in dried sediment where the fine fraction of the sediment may form concretions of larger particle size.

Information collected at site is generally recorded onto a field form then later entered into a database on a PC. BGS has tested hand-held computers, with GPS attachment, for inputting data directly into a digital field database (Scheib, 2005). Although these offer the potential for greater efficiency in creating the field database, they still have an unproven reliability in areas of difficult terrain and extremes of climate, and are not suitable for use by untrained samplers. GPS has greatly assisted in the accurate positioning of sample sites but where reliable topographic maps are available grid references from these are still the prime locational reference. It should be borne in mind that in steep-sided stream gorges or wooded areas GPS units can report inaccurate coordinates.

### ***Representative nature of drainage sediments***

Much literature is available on just what a drainage sediment represents, particularly with respect to trying to trace anomaly trains from mineralization (e.g. Hawkes, 1976; and Ottesen and Theobald, 1994). Potentially, drainage sampling has a great advantage over other types of sample media (such as soil or rock sampling) which have a much reduced area of representativity and are far more inhomogeneous. Soil sampling presents considerable problems for regional geochemical mapping because of: the variation in soil types; the variable nature of horizons and the depths at which they occur; the limited cover in upland areas; and the wide variation in pH and Eh in soils which critically affects the solubility and concentration of metals (Plant and Moore, 1979). However, Plant and Moore (1979) do concede that soils may be the optimum medium in agricultural areas of lowland England particularly for larger scale geochemical maps.

The nature of the processes that combine to produce the water or detritus at a stream sampling site mean that it is unlikely that the sample is truly representative of the entire drainage basin upstream from the site (Ottesen et al., 1989; Bölviken et al., 2004; and Peh et al., 2006). While the fine sediment of overbank and flood plain alluvium in certain environments can be more representative of the drainage catchment, generally they have more limited applicability because they are a composite from a very broad area on account of the order of the drainage basin with which they are associated. The long established and widely employed method of stream sediment sampling (see listing in Plant et al., 1988, 1997) testify to the fact that this method is the preferred method of regional mapping that, providing the sampling procedure has been strictly followed, consistently produces satisfactory regional geochemical maps. There are specific parts of the procedure (e.g. the settling of the fine sediment) that are designed to address some of the issues of representativity (see discussion at the end of Plant and Moore, 1979) and further emphasises the importance of following instructions in a precise manner.

There are circumstances where the drainage sample does not represent material derived from the basin upstream of the site and these should be dealt with at the orientation phase of the project. Such circumstances would include wind blown material collecting in the drainage channel or exotic materials introduced to the drainage basin through anthropogenic activity.

Anthropogenic activity has significantly impacted on drainage basin systems throughout the world (Owens et al., 2005). Even in the more remote inaccessible regions of the world such as the Amazon basin or the jungles of SE Asia logging activities have significantly changed rainwater run-off and percolation and resulted in huge volumes of soil entering the stream system more rapidly than under natural undisturbed conditions (Fletcher and Muda, 2005). Humans have dammed, straightened, dredged and redirected rivers throughout history. Although most nations of the world are now more appreciative of the importance of good environmental management of river systems there are still many economically less developed communities that would see the river system as the principal means of removing waste and rubbish. If the strategy of the sampling is to determine the presence of anthropogenic contamination, then sampling sites should not seek to avoid these effects. If the survey is concerned with the natural baseline, then anthropogenic effects should be actively avoided by the appropriate selection of sampling sites, such as avoiding old mine dumps or always sampling upstream of urban areas.

Urban environments provide a particularly challenging environment for drainage sampling. For example in 2003 BGS adapted its standard regional drainage sampling methods to carry out a drainage survey of the city of Glasgow, Scotland (Fordyce et al., 2004). Access to sampling sites was difficult in the city environment and the project was greatly helped by the involvement of Glasgow City Council. The adaptability of the drainage sampling method for use in both rural and urban environments enabled a direct comparison between rural and urban sediments and waters. A quantitative assessment of the impact of urbanisation and industry can then be made by comparing the rural and urban areas with similar geological settings. The Glasgow urban survey saw the G-BASE project involved for the first time in the analysis of drainage samples for organic compounds (Total Petroleum Hydrocarbons (TPH); Polycyclic Aromatic Hydrocarbon (PAH); Poly-Chlorinated Biphenyls (PCB) and Organo-Tin). The survey highlighted the many difficulties and procedural changes that were needed in the collection and storage of drainage sediment samples to be analysed for organic compounds.

The introduction of wind blown sediment from outside the drainage basin is not a problem in the United Kingdom but it was an issue that BGS had to address during orientation studies for reconnaissance geochemical mapping in the semi-arid Anti-Atlas mountains of Morocco. As the area was located to the north of the Sahara Desert, there was more than ample evidence of wind blown deposits and a sampling strategy had to be devised to minimise any dilution by wind-blown sediment. The orientation was carried out by the chemical analysis of many fraction sizes of the stream sediment along stream channels down from mineralised and unmineralised areas. This work suggested a coarser fraction of sediment ( $>250 \mu\text{m}$ ) was more appropriate for this type of climatic zone (British Geological Survey, 1999a). Evidence from Ti/Zr ratios suggested some aeolian dilution was present in the finest  $<63 \mu\text{m}$  fraction (Dickson and Scott, 1998).

A further frequently raised issue concerning representativity relates to the as yet undiscussed dimension of time. Concerns of temporal variability are often aired when geochemical maps based on drainage samples collected over many years are compiled. This is particularly the case for stream waters where even daily let alone seasonal variations in the water system might be expected to cause considerable variability in element concentrations. Geochemical maps produced by BGS have consistently shown that this is not the case and is a tribute to the robustness of the sampling method. In the stream water geochemical atlas of Wales (British Geological Survey, 1999b), in spite of the documented influence that temporal variations are known to have on stream water composition, it is spatial controls that predominate at a regional scale (Hutchins et al., 1999). Indeed, analytical uncertainty in the geochemical maps is probably more significant than any temporal variations. The drainage sampling of the Tellus Project in Northern Ireland in 2004 extended the stream sediment and water sampling carried out by the G-BASE project in 1994-1996. Again, compilation of the two data sets derived from samples collected more than ten years apart shows the dominance of spatial controls over temporal ones.

### ***Other drainage site media***

This account has been specifically concerned with stream sediments, stream waters and panned heavy mineral concentrates, all collected from the same site. For the G-BASE project the stream sediments and stream waters are submitted for inorganic chemical analyses, water samples benefiting by improvements to detection limits in the past decade enabling ultra-low element concentrations to now be reported. The panned heavy mineral concentrates have not generally been analysed unless follow-up work has been carried out. However, all are inspected at site and observed minerals and contaminants are recorded. The samples are an excellent resource for identifying drainage catchment mineralisation and lithologies as well as anthropogenic contamination (Photograph 1). Indeed, all the G-BASE excess samples are stored at the National Geological Data Centre, Keyworth, UK and are available for further study. The value of excess sample powders in research should not be underestimated.

The availability of other sample media at a drainage site has been briefly mentioned previously. The dirty water filters with the > 45 µm suspended sediment captured on the filter disks could be very useful in studies of the suspended-sediment load. The Fe and Mn coatings on pebbles and other chemical precipitates (e.g. insoluble iron hydroxides) could also be collected as these are known to have good scavenging properties for certain trace elements.

## **CONCLUSIONS**

1. Drainage samples, specifically stream waters and sediments in this account, have a long and well-established use in geochemical and environmental studies and given the right climatic and geomorphological conditions, should be the sampling media of choice.
2. A single drainage site enables the environmental scientists to study several different media at one location, each of which can assist in interpreting the chemical behaviour and distribution of an element in the surface environment.
3. There are issues relating to how representative of the drainage catchment results from drainage samples are. Geochemical maps from many areas of the world have repeatedly proven the accurate representation of drainage basin geochemistry using stream sediments.
4. Representativity can be addressed in an orientation phase of a project and can be satisfied by following strict well-documented procedures. Such procedures will address issues of health and safety as well as quality control.
5. There is surprisingly little temporal control on the spatial patterns on water or stream sediment geochemical maps where samples may have been collected over periods of many years. Analytical method variability over a period of time is generally a bigger problem than any temporal effects when creating seamless geochemical maps for drainage samples collected over a long period of time.

## ACKNOWLEDGEMENTS

This chapter is published with the permission of the Director of the British Geological Survey (NERC). Figures 1 and 6 were prepared by Lauren Noakes and Henry Holbrook respectively (both BGS).

## REFERENCES

- Andrews-Jones, D.A.. 1968. The application of geochemical techniques to mineral exploration. Colorado School of Mines, Mineral Indus. Bull., 11, No 6.
- Bolviken, B., Bogen, J., Jartun, M., Langedal, M., Ottesen, R.T., Volden, T. 2004. Overbank sediments: a natural bed blending sampling medium for large - scale geochemical mapping. *Chemometrics And Intelligent Laboratory Systems*, Vol. 74, 183-199.
- British Geological Survey. 1999a. Résultats de l'étude d'orientation et analyses chimiques des "Stream Sediments" dans le domaine de l'Anti-Atlas (Maroc). *British Geological Survey Report prepared for the Moroccan Ministry of Mines and Energy*, Rabat, Morocco.
- British Geological Survey. 1999b. *Regional geochemistry of Wales and part of west-central England: stream water*. (Keyworth, Nottingham: British Geological Survey.) ISBN 0 85272 363 6.
- Caley, E.R., Richards, J.F.C. 1956. *Theophrastus on Stones: Introduction Greek Text, English Translation, and Commentary*. (Columbus, Ohio, USA: The Ohio State University.)
- Cooper, D.C., Thornton, I. 1994. *Drainage geochemistry in contaminated terrains*. 447-497 in *Drainage Geochemistry*. Hale, M., and Plant, J.A. (editors). *Handbook of Exploration Geochemistry*, 6. (Amsterdam: Elsevier.)
- Darnley, A.G., Bjorklund, A., Bolviken, B., Gustavsson, N., Koval, P.V., Plant, J.A., Steenfelt, A., Tauchid, M., Xuejing, X. 1995. A global geochemical database for environmental and resource management. *UNESCO publishing*, 19.
- Dickson, B.L., Scott, K.M. 1998. Recognition of aeolian soils of the Blayney district, NSW: implications for mineral exploration. *Journal of Geochemical Exploration*, Vol. 63, 237-251.
- Ettler, V., Mihaljevic, M., Sebek, O., Molek, M., Grygar, T., Zeman, J. 2006. Geochemical and Pb isotopic evidence for sources and dispersal of metal contamination in stream sediments from the mining and smelting district of Pribram, Czech Republic. *Environmental Pollution*, Vol. 142, 409-417.
- Fersman, A.E. 1939. Geochemical and mineralogical methods of prospecting for useful minerals. in *U.S. Geol. Surv. Circ. 127, 1952, 37pp*. (US Geological Survey.)
- Fletcher, W K, Muda, J. 2005. Dispersion of gold in stream sediments in the Sungai Kuli region, Sabah, Malaysia. *Geochemistry: Exploration, Environmental, Analysis*, Vol. 5, 211-214.
- Fordyce, F.M., Dochartaigh, B.É.Ó., Lister, T.L., Cooper, R., Kim, A.W., Harrison, I., Vane, C.H., Brown, S.E. 2004. Clyde Tributaries: Report of Urban Stream Sediment and Surface Water Geochemistry for Glasgow. *British Geological Survey, Keyworth, UK, Commissioned Report No. CR/04/037*.
- Gonçaves, M.A., Nogueira, J.M.F., Figueiras, J., Putnis, C.V. 2004. Base-metals and organic content in stream sediments in the vicinity of a landfill. *Applied Geochemistry*, Vol. 19, 137-151.
- Hale, M. 1994. Strategic choices in drainage geochemistry. 111-144 in *Drainage Geochemistry*. Hale, M., and Plant, J.A.. (editors). *Handbook of Exploration Geochemistry*, 6. (Amsterdam: Elsevier.)
- Hale, M., Plant, J.A. 1994. *Drainage Geochemistry*. Handbook of Exploration Geochemistry. No. 6. (Amsterdam: Elsevier.)
- Hawkes, H.E. 1976. The downstream dilution of stream sediment anomalies. *Journal of Geochemical Exploration*, Vol. 6, 345-358.
- Hawkes, H.E., Bloom, H. 1955. Heavy metals in stream sediment used as exploration guides. *Mining Engineer*, Vol. 8, 1121-1126.

Hutchins, M.G., Smith, B., Rawlins, B.G., Lister, T.R. 1999. Temporal and spatial variability of stream waters in Wales, the Welsh borders and part of the West Midlands, UK. 1. Major ion concentrations. *Water Research*, Vol. 33, 3479-3491.

Institute of Hydrology. 2003. *Hydrological data UK. Hydrometric Register and Statistics 1996-2000*. (Institute of Hydrology, NERC, Wallingford, England.)

ISO 5667-12:1995. Water quality - Sampling - Part 12: Guidance on sampling of bottom sediments.

Johnson, C.C. 2005. 2005 G-BASE Field Procedures Manual. *British Geological Survey, Keyworth, UK*, Internal Report No. IR/05/097.

Johnson, C.C., Lister, T.R., Flight, D.M.A., Ander, E.L. 2007. Data conditioning of environmental geochemical data: quality control procedures used in the British Geological Survey's Regional Geochemical Mapping Project. Chapter ?? in this book.

Johnson, C.C., Breward, N., Ander, E.L., Ault, L. 2005. G-BASE: baseline geochemical mapping of great Britain and northern Ireland. *Geochemistry-Exploration Environment Analysis*, Vol. 5, 347-357.

Johnson, C.C., Flight, D.M.A., Lister, T.R., Strutt, M.H. 2001. La rapport final pour les travaux de recherches géologique pour la réalisation de cinq cartes géochimique au 1/100 000 dans le domaine de l'Anti-Atlas (Maroc). *British Geological Survey Confidential Internal Report prepared for the Moroccan Ministry of Mines and Energy*, Commissioned Report Series, No.CR/01/031.

Lee, S., Moon, J-W., Moon, H-S. 2003. Heavy metals in the bed and suspended sediments of Anyang River, Korea: Implications for water quality. *Environmental Geochemistry And Health*, Vol. 25, 433-452.

Lovering, T.S, Huff, L.C., Almond, H. 1950. Dispersion of copper from the San Manuel copper deposit, Pinal County, Arizona. *Economic Geology*, Vol. 45, 493-514.

Muchsin, M., Johnson, C.C., Crow, M.J., Djumsari, A., Sumartono. 1997. *Atlas Geokimia Daerah Sumatera Bagian Selatan/ Geochemical Atlas of Southern Sumatra*. Regional Geochemical Atlas Series of Indonesia. No. 2. (Directorate of Mineral Resources, Bandung, Indonesia and British Geological Survey, Keyworth, UK.)

Ottesen, R.T., Bogen, J., Bölviken, B., and Volden, T. 1989. Overbank sediment: a representative sample medium for regional geochemical mapping. *Journal Of Geochemical Exploration*, Vol. 32, 257-277.

Ottesen, R.T., and Theobald, P.K. 1994. Stream sediments in mineral exploration. 147-184 in *Drainage Geochemistry*. Hale, M., and Plant, J.A. (editors). *Handbook of Exploration Geochemistry*, 6. (Amersterdam: Elsevier.)

Owens, P.N., Batall, R.J., Collins, A .J., Gomez, B., Hicks, D.M., Horowitz, A .J., Kondolf, G.M., Marden, M., Page, M.J., Peacock, D.H., Petticrew, E.L., Salomons, W., Trustrum, N.A. 2005. Fine-grained sediment in river systems: Environmental significance and management issues. *River Research and Applications*, Vol. 21, 693-717.

Peh, Z., Miko, S., and Mileusnic, M. 2006. Areal versus linear evaluation of relationship between drainage basin lithology and geochemistry of stream and overbank sediments in low-order mountainous drainage basins. *Environmental Geology*, Vol. 49, 1102-1115.

Plant, J.A. 1971. Orientation studies on stream sediment sampling for a regional geochemical survey in northern Scotland. *Transactions of the Institute Mining & Metallurgy*, Vol. 80, 323-346.

Plant, J.A. 1973. A random numbering system for geological samples. *Transactions of the Institute Mining & Metallurgy*, Vol. 82, 63-66.

Plant, J.A, Hale, M., Ridgeway, J. 1988. Developments in regional geochemistry for mineral exploration. *Transactions of the Institute of Mining and Metallurgy, B. Applied Earth Science*, Vol. 97, 116-140.

Plant, J.A, Klaver, G., Locutura, J., Salminen, R., Vrana, K., Fordyce, F.M. 1997. The Forum of European Geological Surveys Geochemistry Task Group: geochemical inventory. *Journal Of Geochemical Exploration*, Vol. 59, 123-146.

- Plant, J.A., Moore, P.J. 1979. Geochemical mapping and interpretation in Britain. *Philosophical Transactions of the Royal Society*, Vol. B288, 95-112.
- Plant, J.A., Raiswell, R.W. 1994. Modifications to the geochemical signatures of ore deposits and their associated rock in different surface environments. 73-109 in *Drainage Geochemistry*. Hale, M., and Plant, J.A. (editors). *Handbook of Exploration Geochemistry*, 6. (Amsterdam: Elsevier.)
- Ranasinghe, P.N., Chandrajith, R.L.R., Dissanayake, C.B., Rupasinghe, M.S. 2002. Importance of grain size factor in the distribution of trace elements in stream sediments of tropical high grade terrains – A case study from Sri Lanka. *Chemie der Erde Geochemistry*, Vol. 62, 243- 253.
- Salminen, R., Batista, M.J., Bidovec, M., Demetriades, A., De Vivo, B., De Vos, W., Duris, M., Gilucis, A., Gregorauskiene, V., Halamic, J., Heitzmann, P., Lima, A., Jordan, G., Klaver, G., Klein, P., Lis, J., Locutura, J., Marsina, K., Mazrek, U.A., O'Connor, P.J., Olsson, S.Å., Ottesen, R.T., Petersell, V., Plant, J.A., Reeder, S., Salpeteur, I., Sandström, H., Siewers, U., Steenfelt, A., Tarvainen, T. 2005. *Geochemical Atlas of Europe. Part 1 - Background Information, Methodology and Maps*. Geochemical Atlas of Europe. (Geological Survey of Finland.) ISBN 951-690-921-3
- Salminen, R., Tarvainen, T., Demetriades, A., Duris, M., Fordyce, F.M., Gregorauskiene, V., Kahelin, H., Kivisilla, J., Klaver, G., Klein, P., Larson, J.O., Lis, J., Locutura, J., Marsina, K., Mjartanova, H., Mouvet, C., O'Connor, P., Odor, L., Ottonello, G., Paukola, T., Plant, J.A., Reimann, C., Schermann, O., Siewers, U., Steenfelt, A., Van der Sluys, J., De Vivo, B., Williams, L. 1998. FOREGS geochemical mapping field manual. *Geological Survey of Finland, Guide 47*.
- Scheib, A.. 2005. G-BASE Trials of SIGMA Digital Field Data Capture; Feedback and Recommendations. *British Geological Survey, Keyworth, UK*, Internal Report No. IR/05/015.
- Schreck, P., Schubert, M., Freyer, M., Treutler, H.C., Weiss, H. 2005. Multi-metal contaminated stream sediment in the Mansfeld mining district: metal provenance and source detection. *Geochemistry-Exploration Environment Analysis*, Vol. 5, 51-57.
- Sinclair, A.J. 1983. Univariate Analysis. 57-81 in *Statistics and Data Analysis in Geochemical Prospecting*. Howarth, R.J. (editor). *Handbook of Exploration Geochemistry*, 2. (Amsterdam: Elsevier.)
- Stephenson, B., Ghazhali, S.A., and Harwidjaja. 1982. *Regional Geochemical Atlas of Northern Sumatra*. Regional Geochemical Atlas Series of Indonesia. No. 1. (Directorate of Mineral Resources, Bandung, Indonesia and British Geological Survey, Keyworth, UK.)
- Strahler, A.N. 1957. Quantitative analysis of watershed geomorphology. *Transactions of American Geophysical Union*, Vol. 38, 913-920.
- Thornton, I., and Webb, J.S. 1979. Geochemistry and health in the United Kingdom. *Philosophical Transactions of the Royal Society*, Vol. B288, 151-168.
- Webb, J.S., and Howarth, R.J. 1979. Regional geochemical mapping. *Philosophical Transactions of the Royal Society*, Vol. B288, 81-93.
- Wertime, T.A. 1973. The beginning of metallurgy: a new look. *Science*, Vol. 182, 875-887.
- Williams, T.M., Dunkley, P.N., Cruz, E., Actimbay, V., Gaibor, A., Lopez, E., Baez, N., Aspden, J.A. 2000. Regional geochemical reconnaissance of the Cordillera Occidental of Ecuador: economic and environmental applications. *Applied Geochemistry*, Vol. 15, 531-550.
- Young M.E., Smyth, D. 2005. New geoscience surveys in Northern Ireland. *European Geologist*, No.19, pp. 24-26. European Federation of Geologists, Brussels, Belgium

## List of Photographs

Photograph 1: Anthropogenic contamination seen in heavy mineral panned concentrates.



## List of Tables

Table 1 : Explanation of terms used in drainage sampling

Table 2: Summary of some typical element associations found in stream sediments

Table 3: Relative mobility of elements in the different surface environments

Table 4: List of sampling equipment for collecting stream sediments, stream waters and panned concentrates as used by the G-BASE project

Table 5: Summary of the main health and safety issues for the G-BASE project in the UK and suggested mitigating actions

## List of Figures

Figure 1: Example of the delineation of drainage basins by watershed and the Strahler (1957) system for determining stream order

Figure 2: An example from the G-BASE project of a gridded image for arsenic in stream sediments (top) and stream waters (bottom) from Eastern England

Figure 3: Example of field form used for recording information at a drainage sample site

Figure 4: Organisational chart of personnel for a typical sampling project

Figure 5: Diagram of a nested sieve set used for stream sediment sampling

Figure 6: A typical sediment sampling site (temperate zone) for 1<sup>st</sup> or 2<sup>nd</sup> order stream

Figure 7: Flow chart summarising the procedures at a drainage site for the collection of stream water, sediment and heavy mineral concentrate.

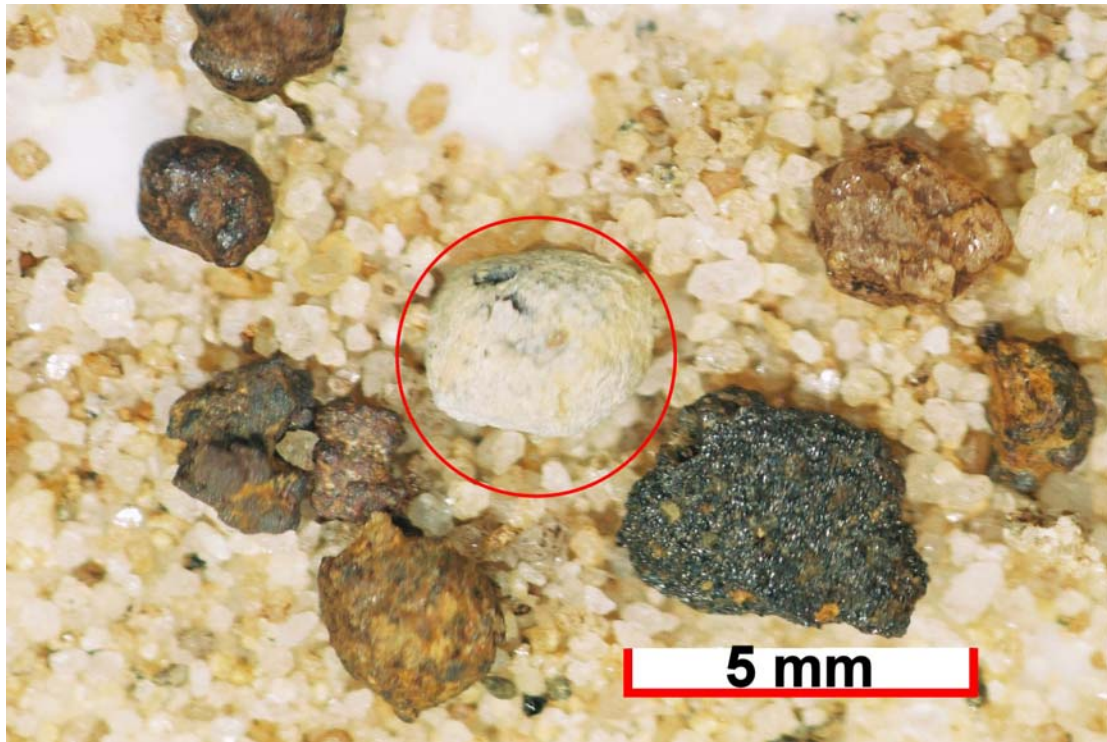

Photograph 1: Anthropogenic contamination observed in some G-BASE panned heavy mineral concentrates. *Top* – Sample 307349P showing oxidised lead shot. *Bottom* – Sample 307364P showing steel shot and a flake of paint.

<b>TERM</b>	<b>DEFINITION</b>
Alluvium	a recent deposit of sand, mud, etc., formed by flowing water
Confluence	where two streams merge. If the streams are of equal size then the confluence is often referred to as a “fork”
Dispersion train	is a feature of variable length found extending downstream from a point and defined by the decreasing presence of a mineral or chemical element
Drainage basin	a region of land where water from precipitation (or snowmelt) drains downhill into a body of water such as a stream. Drainage basins are divided from each other by topographic barriers called a watershed. Also referred to as drainage catchment, water basin or drainage area. Drainage basins can be nested together to form larger basins that can be described by the rank of the largest river, e.g. 4 <sup>th</sup> order drainage basin
Ephemeral	a term used to describe a stream that forms only during or immediately after precipitation
Floodplain sediment	alluvium accumulated adjacent to high-order stream
Headwater	the section of the stream closest to its source where a discernable stream bed can be identified
Heavy mineral concentrate	in this context is a sub-sample of the stream sediment that has been created by separating out the heavier minerals present in the stream sediment. The most common way of doing this is by panning the sediment to give a panned concentrate
Hydrology	the science dealing with the occurrence, circulation, distribution, and properties of the waters of the earth and its atmosphere
Intermittent	a term used to describe a stream that only flows for part or parts of the year
Mouth	the point at which the stream discharges into a “static” body of water such as a lake or ocean
Overbank sediment	alluvium accumulated adjacent to low-order stream
Perennial	a term used to describe a stream that flows all year
River	a large natural stream
Source	a spring from which the stream emerges or other point of origin
Spring	the point at which a stream emerges at the land surface
Stream	a body of water with a detectable current confined within a bed and banks. A general term applied to all flowing natural waters regardless of size. Regional names may be used such as beck, bourne, brook, burn, kill, creek or run
Stream bed	the base of a stream
Stream order	hierarchical system of ranking streams whereby low-order streams are small and high-order streams big
Stream sediment	represents a composite sample of detrital material derived from the drainage basin upstream of the sample site. Typically composed of weathered bedrock and material derived from overburden and is generally applied to the <2 mm fraction. Anything bigger than this is generally referred to as clasts, pebbles, stones or boulders
Thalweg	is the stream’s longitudinal section, i.e. a line joining the deepest point in the channel at each stage from source to mouth
Tributary	a stream joining another stream. When streams of similar size join they are referred to as a “branches”
Watershed	is a topographic feature dividing drainage basins though American terminology would actually refer to the whole area enclosed by the topographic feature as the watershed

**Table 1 : Explanation of terms used in drainage sampling**

<b>Geological or environmental features</b>	<b>Principal associated elements and element ratios</b>
Carbonate rocks (limestones, dolomites, calc-schist)	CaO Sr MgO
Argillaceous and pelitic source rocks	Li B Ga
Argillaceous Red Beds (eg Mercia Mudstone) with evaporites	K <sub>2</sub> O MgO Sr <i>Se</i>
Black shales and graphitic schists	Ba Mo V U <i>Cu Ni Ag Se Cd</i>
Sedimentary ironstones	Fe <sub>2</sub> O <sub>3</sub> As P <sub>2</sub> O <sub>5</sub> U
Basic igneous rocks in unmineralised areas	MgO TiO <sub>2</sub> Ni Cu V/Cr
Ultrabasic rocks and derived sediments	Cr MgO Ni Cr/V
Evolved granites	Be Li U Sn Rb/K <sub>2</sub> O <i>Y La Mo</i>
'Normal' Granites	Be K <sub>2</sub> O Rb U Li <i>Sr</i>
Granodiorites and some intermediate igneous rocks	Be Sr Ca K <sub>2</sub> O
Resistate elements for sediment provenance variation, especially in greywackes and arenites	La Y Zr TiO <sub>2</sub> Th Ce Nb - and ratios of these.
Generalised Urban – industrial contamination	Sn Pb Cu Sb Cd Zn
Industrial contamination – heavy engineering	Sn Pb Cu Sb Cd Zn Cr Ni V Mn
Secondary hydrous oxide formation in stream sediments	Mn Co As Al Fe <sub>2</sub> O <sub>3</sub>
Mineralisation (vein type sulphide)	Pb Zn Ba Cu Cd <i>Sb Bi As</i>
Mineralisation (Red-bed type)	Ba Cu <i>Bi Ag</i>
Mineralisation (porphyry type)	Mo Cu Sb
Gold mineralisation ('pathfinder' elements)	As Sb Bi

**Table 2: Summary of some typical element associations found in stream sediments (elements in italics are not of primary importance in the association)**

Relative mobilities	Environmental Conditions			
	Oxidising	Acid	Neutral to alkaline	Reducing
Very high	Cl, I, Br S, B	Cl, I, Br S, B	Cl, I, Br S, B Mo, V, U, Se, Re	Cl, I, Br
High	Mo, V, U, Se, Re Ca, Na, Mg, F, Sr, Ra Zn	Mo, V, U, Se, Re Ca, Na, Mg, F, Sr, Ra Zn Cu, Co, Ni, Hg, Ag, Au	Ca, Na, Mg, F, Sr, Ra	Ca, Na, Mg, F, Sr, Ra
Medium	Cu, Co, Ni, Hg, Ag, Au As, Cd	As, Cd	As, Cd	
Low	Si, P, K Pb, Li, Rb, Ba, Be Bi, Sb, Ge, Cs, Tl	Si, P, K Pb, Li, Rb, Ba, Be Bi, Sb, Ge, Cs, Tl Fe, Mn	Si, P, K Pb, Li, Rb, Ba, Be Bi, Sb, Ge, Cs, Tl Fe, Mn	Si, P, K   Fe, Mn
Very low to immobile	Fe, Mn Al, Ti, Sn, Te, W Nb, Ta, Pt, Cr, Zr Th, Rare Earths	Al, Ti, Sn, Te, W Nb, Ta, Pt, Cr, Zr Th, Rare Earths	Al, Ti, Sn, Te, W Nb, Ta, Pt, Cr, Zr Th, Rare Earths Zn Cu, Co, Ni, Hg, Ag, Au	Al, Ti, Sn, Te, W Nb, Ta, Pt, Cr, Zr Th, Rare Earths Zn Cu, Co, Ni, Hg, Ag, Au S, B Mo, V, U, Se, Re As, Cd Pb, Li, Rb, Ba, Be Bi, Sb, Ge, Cs, Tl

**Table 3: Relative mobility of elements in the different surface environments (taken from Plant and Raiswell, 1994 based on that of Andrews-Jones, 1968)**

ITEM	COMMENTS
<b>General</b>	
Topographic maps of field area	Scale as required by project. Need to have clean copies to be used as “master plots” and working copies for daily use by samplers
Geological and other maps	Maps such as geology, land-use, soil type etc. to help provide samplers with supplementary information about sites and catchments
Binocular microscope and lamp	Used to assist identification of panned concentrate minerals/contaminants
Field forms and folders	Field forms as illustrated in Figure 3 and a folder to keep them dry and clean. Ideally could be replaced by hand held computer devices
Stationery	Permanent ink markers, biro, pencils, elastic bands, etc.
Communication devices	Mobile phones or short-wave radio if no mobile phone coverage
Sample number checklist	Used for allocating numbers and collating samples
ID passes and letters	Sampling will attract local attention and a sampler’s ID and their mission needs to be clearly stated and permitted
First aid kit	To include survival aids such as whistle and survival bags if needed
High visibility jackets	Required in all working environments
Rucksacks	Each sampling pair require an equipment rucksack and a sample rucksack
Geological hammer and hand lens	Goggles to be used when hammering. Hand lens to look at rocks and minerals
GPS and compass	Used for locating sites and navigating
Knox Protractor	Used for measuring and plotting points on maps
Portable computer	If practical in field location a PC can be used to database field data or with GIS can be used to plan sampling
<b>Stream Sediment</b>	
Sieve set	See Figure 5. Ideally made of wood with nylon mesh fixed together with nylon bolts plus fibre glass pan for collecting sediment
Plastic funnel	To be used to help pour sample into sample bag
Rubber gloves	To be used to help rub sediment through sieve mesh
Sample bags	Kraft™ strong paper 4”x 8” (10 x 20 cm) sample bag stuck with waterproof glue. Paper allows sediment to dry.
Plastic bags and containers for transporting samples	Miscellaneous plastic bags are required to place samples for transport to prevent leakages. Also rigid plastic containers are useful to protect samples in the rucksack
Trenching tool/shovel	Wooden, polyethylene/polypropylene, stainless steel with any paint stripped off
<b>Stream Water</b>	
Plastic syringe	25 ml syringes
Millex™ sealed filters	Pre-loaded with 0.45 µm Millipore cellulose filters
Plastic bags	Miscellaneous self-seal plastic bags for keeping dirty and clean equipment apart
30 ml polythene bottles	For collecting water sample for pH determination in field lab
250 ml Nalgene™ polythene bottle	For collecting water sample to be determined for alkalinity and conductivity in the field lab
30 ml Nalgene™ polythene bottle	For collecting filtered unacidified sample (for major anions/NPOC)
60 ml Nalgene™ polythene bottle	For collecting filtered acidified sample (for ICP-MA & -AES)
Conc. HNO <sub>3</sub> and dropping pipette	Used to acidify water samples in field base
<b>Panned Concentrate</b>	
Pan	Variety of types of pan available
Sample bags	Kraft™ strong paper 3”x 5” (8 x 13 cm) sample bag
<b>Suspended load</b>	
Self-seal plastic bag	3”x 5” (8 x 13 cm) bag with white panel for storing “dirty” filter from water sample collection

**Table 4: List of sampling equipment for collecting stream sediments, stream waters and panned concentrates as used by the G-BASE project**

High/Medium risk activity	Summary of measures to reduce risk
Driving in field area	<ul style="list-style-type: none"> <li>• receive appropriate vehicle driving training</li> <li>• use vehicle appropriate for type of fieldwork</li> </ul>
Transporting heavy loads and equipment by vehicle	<ul style="list-style-type: none"> <li>• do not overload vehicles</li> <li>• secure equipment and samples</li> <li>• transport acid in special anti-spill containers</li> </ul>
Lifting heavy loads/ loading and unloading samples	<ul style="list-style-type: none"> <li>• receive manual handling training</li> <li>• use appropriate storage crates for sample transportation</li> <li>• don't overload storage crates</li> <li>• do not load/unload heavy items alone</li> </ul>
Carrying heavy loads in the field	<ul style="list-style-type: none"> <li>• use good quality rucksacks offering high level of support and adjusted appropriately for the carrier</li> <li>• share the load between the two samplers</li> <li>• sensible handling of load whilst negotiating obstacles (e.g. pass load across a wall rather than climbing over the wall with rucksack still on)</li> </ul>
Sampling drainage samples	<ul style="list-style-type: none"> <li>• attend sampling training day</li> <li>• dress appropriately with good footwear and always take waterproof clothing</li> <li>• stick to recognised paths. Do not take risks crossing barbed wire fences/stone walls or rivers/streams for the sake of making a shortcut</li> </ul>
Walking on roads used by frequent traffic	<ul style="list-style-type: none"> <li>• always use Hi-vis jackets and rucksacs with Hi-vis strips</li> <li>• seek alternative footpaths if available</li> <li>• where no footway, walk into oncoming traffic except when approaching the brow of a hill</li> </ul>
Remote working	<ul style="list-style-type: none"> <li>• always sample in pairs</li> <li>• inform team leaders of proposed route</li> <li>• carry emergency telephone contact numbers</li> </ul>
Adverse weather	<ul style="list-style-type: none"> <li>• pay attention to weather forecasts</li> <li>• do not sample areas in times of flood</li> <li>• take appropriate measures against exposure to the sun</li> <li>• during thunderstorms follow standard procedures to avoid lightning strikes and in particular don't carry a metal equipment</li> </ul>
Attack by animals	<ul style="list-style-type: none"> <li>• avoid potentially dangerous animals (e.g. bulls and guard dogs) where possible by choosing an alternative route</li> </ul>
Military, shooting area and other hazardous land use	<ul style="list-style-type: none"> <li>• always have permission to enter such areas first</li> <li>• team leaders to advise samplers of such potential areas on their map</li> <li>• team leaders plan daily sampling areas so hazards such as large rivers or railways do not have to be crossed</li> <li>• always wear Hi-vis jackets</li> </ul>
Exposure to infection, agrochemicals and pesticides	<ul style="list-style-type: none"> <li>• samplers to be advised of dangers on training day</li> <li>• avoid contaminated sites or fields being sprayed</li> <li>• observe agricultural exclusion notices when encountered in the field</li> </ul>
Exposure to substances used by the field team	<ul style="list-style-type: none"> <li>• receive training and H&amp;S procedures for handling conc acids</li> <li>• glue sediment and pan bags in a well ventilated area,</li> </ul>

**Table 5: Summary of the main health and safety issues for the G-BASE project in the UK and suggested mitigating actions**

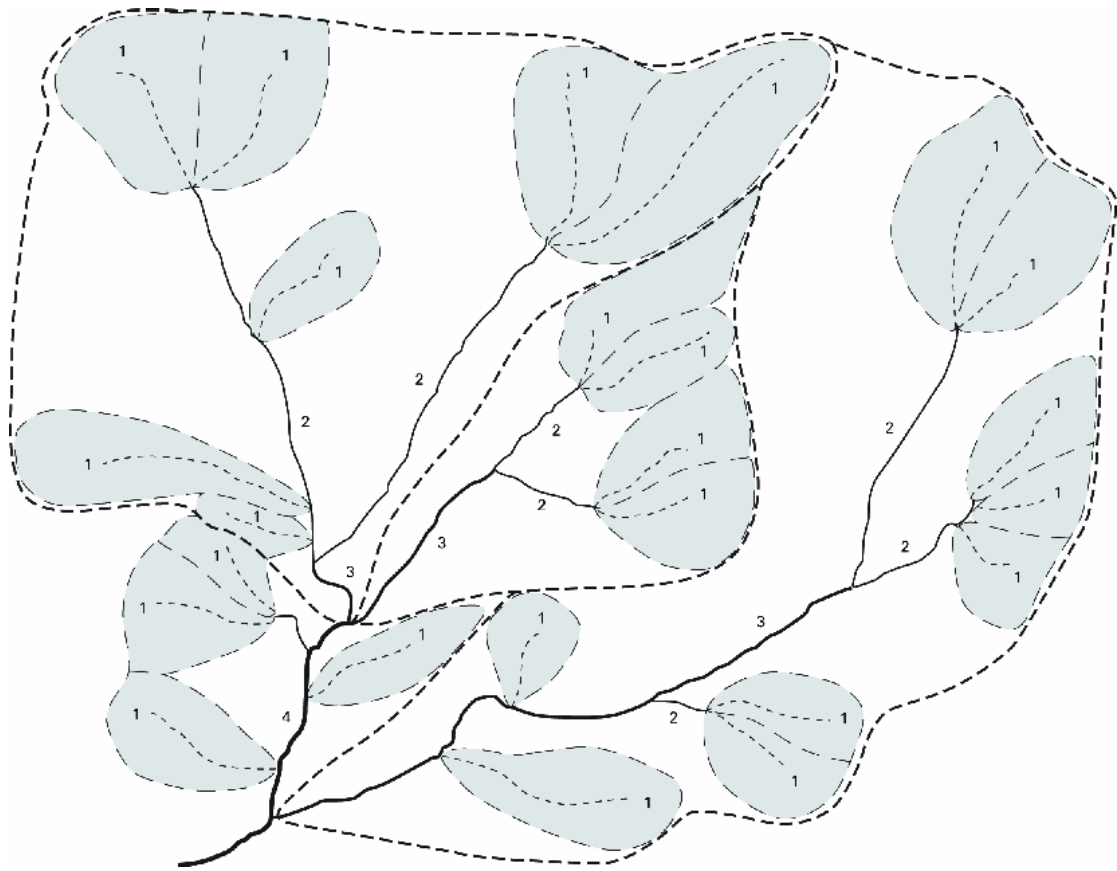

**Figure 1: Example of the delineation of drainage basins by watershed and the Strahler (1957) system for determining stream order**

The shaded areas define the watersheds for the drainage basins of first order streams. Note that the first order basins are components of a much large drainage basins, here the third order drainage basin is defined by the bold dashed line. According to the Strahler system of stream ordering the end tributaries are designated as first order streams. Two first-order streams merge to form a second-order stream segment; two second-order streams join, forming a third-order and so on. It takes at least two streams of any given order joining to form a stream of the next higher order.



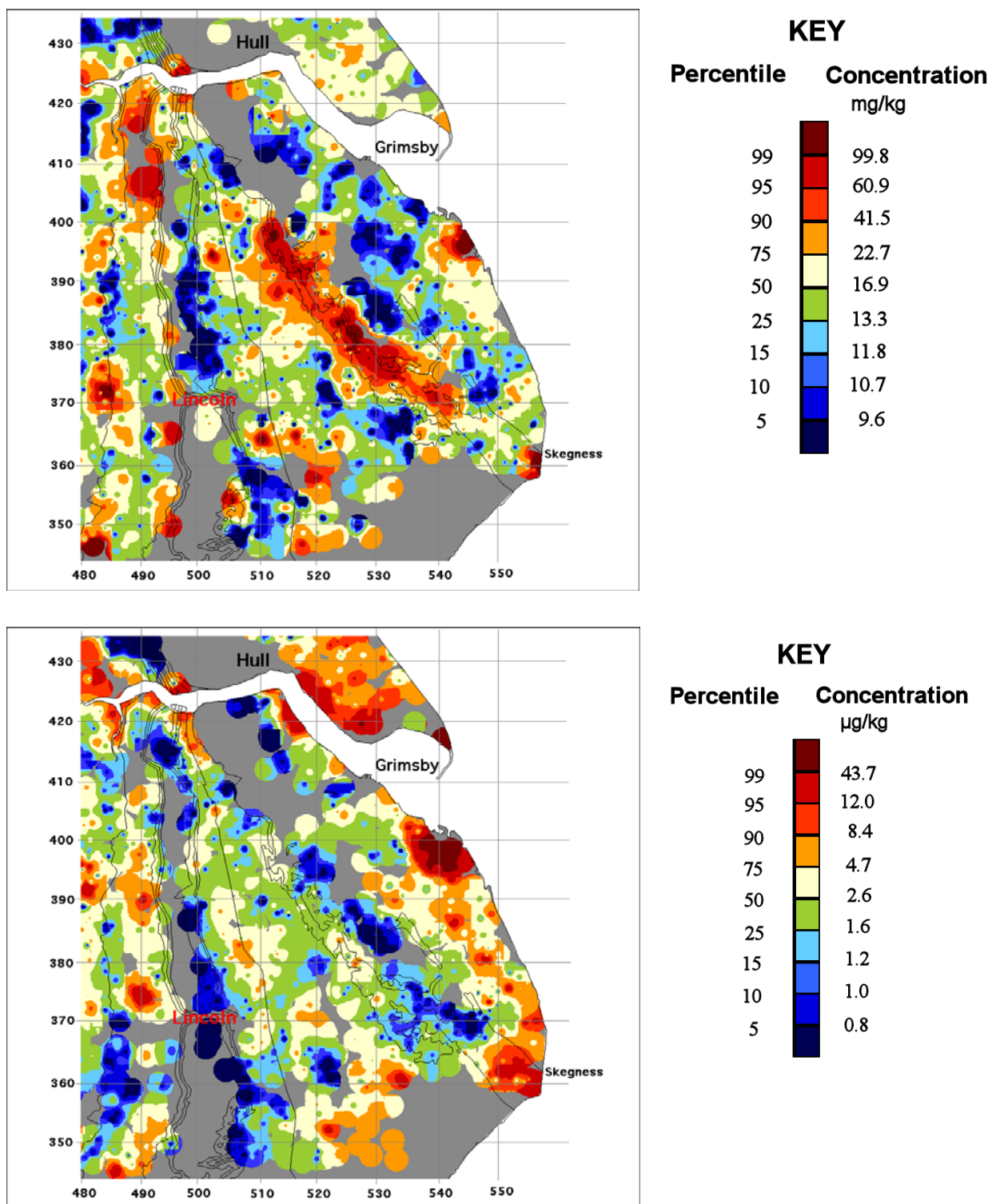

**Figure 2: An example from the G-BASE project of a gridded image for arsenic in stream sediments (top) and stream waters (bottom) from Eastern England. Maps have a 10 km grid outline and show how stream water and stream sediment maps can be used in combination to explain the distribution and behaviour of elements in the surface environment. The Mesozoic sedimentary ironstone referred to in the text outcrops along a north-westerly line from Skegness.**

G-BASE REGIONAL DRAINAGE

CARD	CODE	SAMPLE NUMBER				PROTOCOL	TYPE				EASTING				NORTHING				O/S MAP		SCL		COLLECTORS																
1	1	2	3	4	5	6	7	8	9	10	11	12	13	14	15	16	17	18	19	20	21	22	23	24	25	26	27	28	29	30	31	32	33	34	35	36			
A	DUPLICATE SAMPLE				DATE				WEA				LAND USE				WATER CLR																						
	CODE		SAMPLE NUMBER		DAY		MONTH		YEAR		49		50		51		62		66		CL		YE		BR		SS												
	37	38	39	40	41	42	43	44	45	46	47	48	49	50	51	52	53	54	55	56	57	58	59	60	61	62	63	64	65	66	67	68	69	70	71	72			
B																																							

CARD	SITE LOCALITY DETAILS																																												
2	1									10									20									30									36								
	[Grid for site locality details]																																												
	37 45 55 65 72																																												

CARD	OBS				DRIFT				SITE GEOLOGY				CATCHMENT GEOLOGY				PAN		MIN		MIN		MIN													
3	B/R				MAJOR		MINOR		MAJOR		MINOR		MIN		MIN		MIN																			
	1	2	3	4	5	6	7	8	9	10	11	12	13	14	15	16	17	18	19	20	21	22	23	24	25	26	27	28	29	30	31	32	33	34	35	36

CARD	SEDIMENT DATA																																			
4	STM	DRN	DRN	CLAST PPTS			SED COLOUR			SED COMPOSITION						CONTAMINATION																				
	ORD	TYP	CON	DR	BR	BL	GR	Lb-O	Dd-B	LC	MC	HC	LO	MO	HO	A0	A1	A2	A3	A4	A5	A6	A7	B0	B1	B2	B3	B4	C1	C2	D	E	F	G	H	I
	1	2	3	4	5	6	7	8	9	10	11	12	13	14	15	16	17	18	19	20	21	22	23	24	25	26	27	28	29	30	31	32	33	34	35	36
	STREAM CLAST LITHOLOGY																																			
	37 40 50 60 70 72																																			

CARD	FIELD DATA COMMENTS																																												
5	1									10									20									30									36								
	[Grid for field data comments]																																												
	37 50 60 70 72																																												
	73 80 90 100 108																																												

G-BASE DRAINAGE CARD FOR 2005 Version 2005.2

Figure 3: Example of field form used for recording information at a drainage sample site

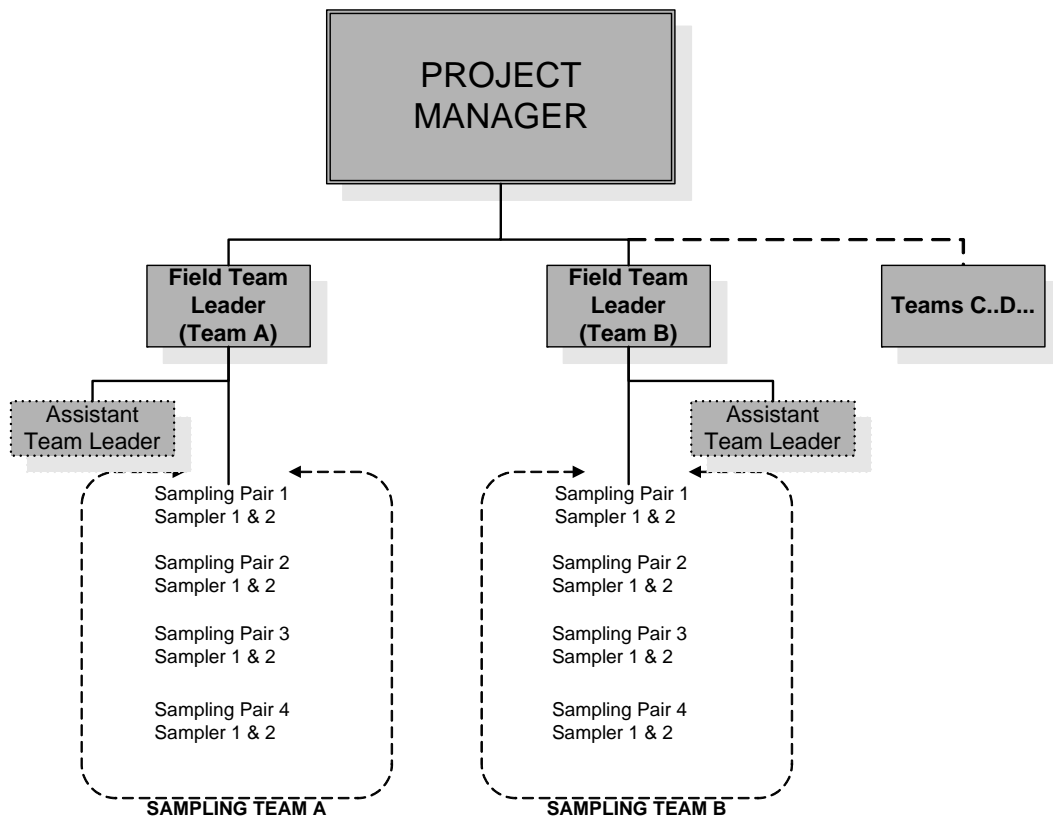

**Figure 4: Organisational chart of personnel for a typical sampling project**

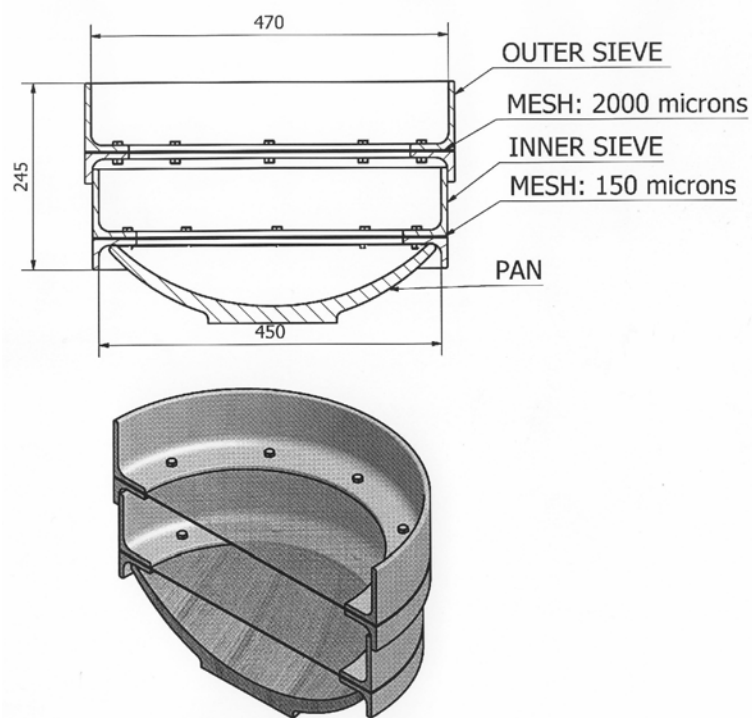

**Figure 5: Diagram of a nested sieve set used for stream sediment sampling. *Top*: cross-section plan view (dimensions in mm). *Bottom*: cut-away 3-D visualisation (from engineering drawing by Humphrey Wallis, BGS for ABS (acetyl butyl styrene) polymer plastic sieve sets).**

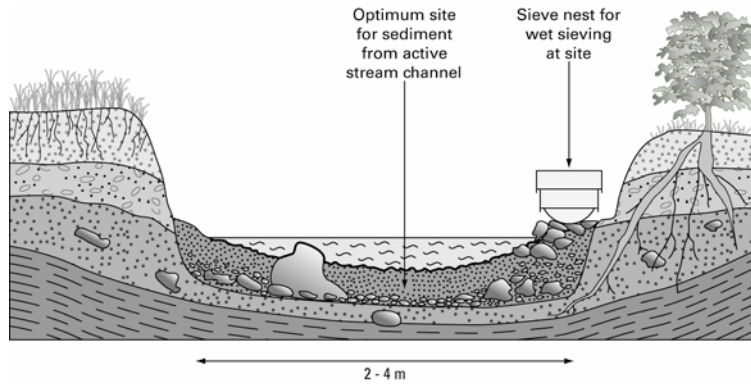

**Figure 6: A typical sediment sampling site (temperate zone) for 1<sup>st</sup> or 2<sup>nd</sup> order stream**

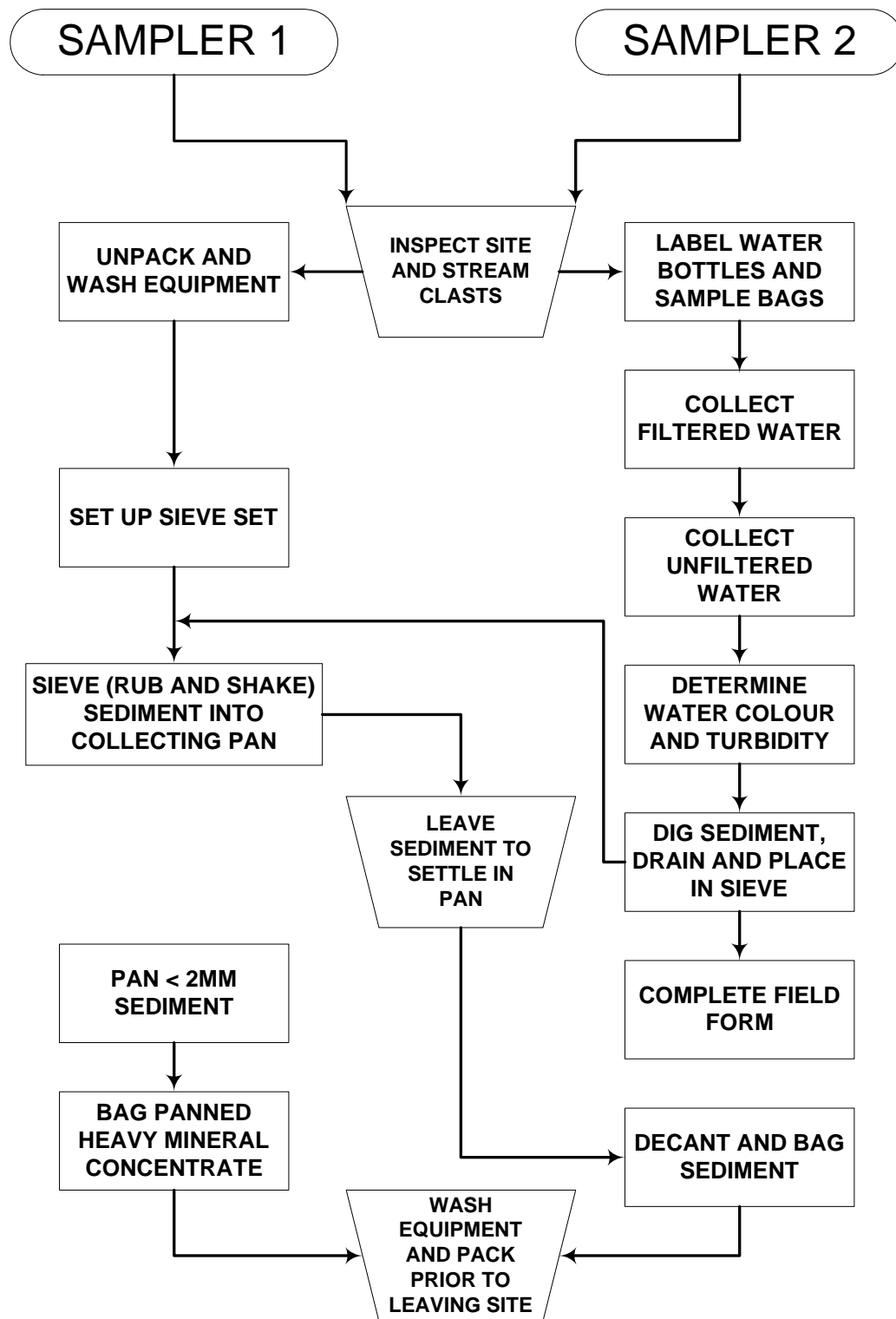

**Figure 7: Flow chart summarising the procedures at a drainage site for the collection of stream water, sediment and heavy mineral concentrate. Certain procedures are repeated when duplicate samples are collected.**