

Coloring Points with Respect to Squares

Eyal Ackerman^{*1}, Balázs Keszegh^{†2}, and Máté Vizer^{‡3}

1 Department of Mathematics, Physics, and Computer Science, University of Haifa at Oranim, Tivon, Israel

ackerman@sci.haifa.ac.il

2 Alfréd Rényi Institute of Mathematics, Hungarian Academy of Sciences, Budapest, Hungary

keszegh@renyi.hu

3 Alfréd Rényi Institute of Mathematics, Hungarian Academy of Sciences, Budapest, Hungary

vizermate@gmail.com

Abstract

We consider the problem of 2-coloring geometric hypergraphs. Specifically, we show that there is a constant m such that any finite set \mathcal{S} of points in the plane can be 2-colored such that every axis-parallel square that contains at least m points from \mathcal{S} contains points of both colors. Our proof is constructive, that is, it provides a polynomial-time algorithm for obtaining such a 2-coloring. By affine transformations this result immediately applies also when considering homothets of a fixed parallelogram.

1998 ACM Subject Classification G.2.2 Graph Theory – Hypergraphs

Keywords and phrases Geometric hypergraph coloring, Polychromatic coloring, Homothets, Cover-decomposability

Digital Object Identifier 10.4230/LIPIcs.SoCG.2016.5

1 Introduction

In this paper we consider the problem of coloring a given set of points in the plane such that every region from a given set of regions contains a point from each color class. To state our results, known results and open problems, we need the following definitions and notations.

A *hypergraph* is a pair $(\mathcal{V}, \mathcal{E})$ where \mathcal{V} is a set and \mathcal{E} is a set of subsets of \mathcal{V} . The elements of \mathcal{V} and \mathcal{E} are called *vertices* and *hyperedges*, respectively. For a hypergraph $H := (\mathcal{V}, \mathcal{E})$, let $H|_m := (\mathcal{V}, \{e \in \mathcal{E} : |e| \geq m\})$. A *proper coloring* of a hypergraph is a coloring of its vertex set such that in every hyperedge not all vertices are assigned the same color. Proper colorability of a hypergraph with two colors is sometimes called *Property B* in the literature. A *polychromatic k -coloring* of a hypergraph is a coloring of its vertex set with k colors such that every hyperedge contains at least one vertex from each of the k colors.

Given a family of regions \mathcal{F} in \mathbb{R}^d (e.g., all disks in the plane), there is a natural way to define two types of finite hypergraphs that are dual to each other. First, for a finite set of points \mathcal{S} , let $H^{\mathcal{F}}(\mathcal{S})$ denote the *primal hypergraph* on the vertex set \mathcal{S} whose hyperedges are

* Most of this work was done during a visit of the first author to the Rényi Institute that was partially supported by Hungarian National Science Fund (OTKA), under grant PD 108406 and by ERC Advanced Research Grant no. 267165 (DISCONV).

† Second author supported by Hungarian National Science Fund (OTKA), under grant PD 108406 and by the János Bolyai Research Scholarship of the Hungarian Academy of Sciences.

‡ Third author supported by Hungarian National Science Fund (OTKA), under grant SNN 116095.



© Eyal Ackerman, Balázs Keszegh, and Máté Vizer; licensed under Creative Commons License CC-BY

32nd International Symposium on Computational Geometry (SoCG 2016).

Editors: Sándor Fekete and Anna Lubiw; Article No. 5; pp. 5:1–5:16

Leibniz International Proceedings in Informatics



Schloss Dagstuhl – Leibniz-Zentrum für Informatik, Dagstuhl Publishing, Germany

all subsets of \mathcal{S} that can be obtained by intersecting \mathcal{S} with a member of \mathcal{F} . We say that a finite subfamily $\mathcal{F}_0 \subseteq \mathcal{F}$ realizes $H^{\mathcal{F}}(\mathcal{S})$ if for every hyperedge $\mathcal{S}' \subseteq \mathcal{S}$ of $H^{\mathcal{F}}(\mathcal{S})$ there is $F' \in \mathcal{F}_0$ such that $F' \cap \mathcal{S} = \mathcal{S}'$. The dual hypergraph $H^*(\mathcal{F}_0)$ is defined with respect to a finite subfamily $\mathcal{F}_0 \subseteq \mathcal{F}$. Its vertex set is \mathcal{F}_0 and for each point $p \in \mathbb{R}^d$ it has a hyperedge that consists of all the regions in \mathcal{F}_0 that contain p .

The general problems we are interested in are the following.

- **Problem 1.** For a given family of regions \mathcal{F} ,
- (i) Is there a constant m such that for any finite set of points \mathcal{S} the hypergraph $H^{\mathcal{F}}(\mathcal{S})|_m$ admits a proper 2-coloring?
 - (ii) Is there a constant m^* such that for any finite subset $\mathcal{F}_0 \subseteq \mathcal{F}$ the hypergraph $H^*(\mathcal{F}_0)|_{m^*}$ admits a proper 2-coloring?
 - (iii) Given a constant k , is there a constant m_k such that for any finite set of points \mathcal{S} the hypergraph $H^{\mathcal{F}}(\mathcal{S})|_{m_k}$ admits a polychromatic k -coloring? If so, is $m_k = O(k)$?
 - (iv) Given a constant k , is there a constant m_k^* such that for any finite subset $\mathcal{F}_0 \subseteq \mathcal{F}$ the hypergraph $H^*(\mathcal{F}_0)|_{m_k^*}$ admits a polychromatic k -coloring? If so, is $m_k^* = O(k)$?

Examples of families \mathcal{F} for which such coloring problems are studied are translates of convex sets [3, 12, 23, 30, 33, 37], homothets of triangles [6, 7, 15, 16, 17, 18], axis-parallel rectangles [11, 28, 26, 10] and half-planes [14, 36]. If \mathcal{F} is the family of disks in the plane then these hypergraphs generalize Delaunay graphs.

The main motivation for studying proper and polychromatic colorings of such geometric hypergraphs comes from cover-decomposability problems and conflict-free coloring problems [35]. We concentrate on the first connection, as the problems we regard are in direct connection with cover-decomposability problems.

Multiple coverings and packings were first studied by Davenport and L. Fejes Tóth almost 50 years ago. Since then a wide variety of questions related to coverings and packings has been investigated. In 1986 Pach [23] published the first paper about decomposability problems of multiple coverings. It turned out that this area is rich of deep and exciting questions, and it has important practical applications as well (e.g., in the area of surveillance systems [12, 25]). Following Pach's papers, most of the efforts were concentrated on studying coverings by translates of some given shape. Recently, many researchers started to study also cover-decomposability of homothets of a given shape.

A family of planar sets is called an r -fold covering of a region R , if every point of R is contained in at least r members of the family. A 1-fold covering is simply called a covering. A family \mathcal{F} of planar sets is called *cover-decomposable*, if there is an integer l with the property that for any region R , any subfamily of \mathcal{F} that forms an l -fold covering of R can be decomposed into two coverings. We can generalize the problem of decomposition into more than 2 coverings, in which case we are interested in the existence of a number l_k such that any subfamily of \mathcal{F} that covers every point in R at least l_k times, can be split into k subfamilies, each forming a covering. If we consider only coverings with finite subfamilies, then we call it the *finite cover-decomposition* problem. One of the first observations of Pach was that if \mathcal{F} is the family of translates of an open convex set, then cover-decomposition is equivalent to finite cover-decomposition.

It is easy to see that the finite cover-decomposition problem is equivalent to Problems 1(ii) and (iv) (i.e., $l = m^*$ and $l_k = m_k^*$ in the notation above). Pach also observed that if \mathcal{F} is the family of translates of an open set, then Problems 1(i) and (ii) are equivalent and also Problems 1(iii) and (iv) are equivalent. That is, it is enough to consider the primal hypergraph coloring problem.

Pach conjectured that translates of every open convex planar set are cover-decomposable [22]. During the years researchers acquired a good understanding of convex planar shapes whose translates are cover-decomposable. On the positive side, Pach's conjecture was verified for every open convex polygon: Pach himself proved it for every open centrally symmetric convex polygon [23], then Tardos and Tóth [37] proved the conjecture for every open triangle, and finally Pálvölgyi and Tóth [33] proved it for every open convex polygon. For open convex polygons we also know that $l_k = O(k)$ [3, 12, 30]. In [33] Pálvölgyi and Tóth also gave a complete characterization of cover-decomposable open concave polygons. Thus, the cover-decomposability problem is settled for translates of an open polygon. However, Pach's conjecture was refuted by Pálvölgyi [32] who showed that it does not hold for a disk and for convex shapes with smooth boundary.

In the three dimensional space it follows from the planar results [31, 32] that every bounded polytope is not cover-decomposable. Thus, it is not easy to come up with a cover-decomposable set in the space. An important exception is the *octant*¹, whose translates were proved to be cover-decomposable [15]. The currently best bounds are $5 \leq l \leq 9$ [18] and $l_k = O(k^{5.09})$ [9, 17, 18]. It is an interesting open problem whether $l_k = O(k)$.

For a long time no positive results were known about cover-decomposability and geometric hypergraph coloring problems concerning homothets of a given shape. For disks, the answer is negative for all parts of Problem 1 [24, 27]. As a first positive result, the cover-decomposability of octants along with a simple reduction implied that both the primal and dual hypergraphs with respect to homothets of a triangle are properly 2-colorable:

► **Theorem 2** ([15, 18]). *For the family \mathcal{F} of all homothets of a given triangle both Problems 1(i) and 1(iii) have a positive answer with $m = m^* \leq 9$.*

This result was later used to obtain polychromatic colorings of the primal and dual hypergraphs defined by the family of homothets of a fixed triangle. For the dual hypergraph, the best bound comes from the corresponding result about octants and so it is $m_k^* = O(k^{5.09})$. For the primal hypergraph there is a better bound $m_k = O(k^{4.09})$ [8, 16, 18]. An important tool for obtaining these results is the notion of *self-coverability* (see Section 2.2), which is also essential for proving our results. It is an interesting open problem whether $m_k = O(k)$ and $m_k^* = O(k)$ for the homothets of a given triangle.

For polygons other than triangles, somewhat surprisingly, Kovács [20] recently provided a negative answer for Problems 1(ii) and (iv). Namely, he showed that the homothets of any given convex polygon with at least four sides are not cover-decomposable. In other words, there is no constant m^* for which the dual hypergraph consisting of hyperedges of size at least m^* is 2-colorable. Our main contribution is showing that this is not the case when considering 2-coloring of the primal graph. Indeed, Problem 1(i) has a positive answer for homothets of any given *parallelogram*.

► **Theorem 3.** *There is an absolute constant $m_q \leq 1484$ such that the following holds. Given an (open or closed) parallelogram Q and a finite set \mathcal{S} of points in the plane, the points of \mathcal{S} can be 2-colored in polynomial time, such that any homothet of Q that contains at least m_q points contains points of both colors.*

This is the first example that exhibits such different behavior for coloring the primal and dual hypergraphs with respect to the family of some geometric regions. Furthermore, combined with results about self-coverability, the proof of Theorem 3 immediately implies

¹ An octant is the set of points $\{(x, y, z) | x < a, y < b, z < c\}$ in the space for some a, b and c .

the following generalization to polychromatic k -colorings, thus partially answering also Problem 1(iii) (it remains open whether linearly many points per hyperedge/parallelogram suffice).

► **Corollary 4.** *Let Q be a given (open or closed) parallelogram and let \mathcal{S} be a set of points in the plane. Then \mathcal{S} can be k -colored, such that any homothet of Q that contains at least $m_k = \Omega(k^{11.6})$ points from \mathcal{S} contains points of all k colors.*

Our proof of Theorem 3 also works for homothets of a triangle, i.e., we give a new proof for the primal case of Theorem 2 (with a larger constant though):

► **Theorem 5 ([15]).** *There is an absolute constant m_t such that the following holds. Given an (open or closed) triangle T and a finite set \mathcal{S} of points in the plane, the points of \mathcal{S} can be 2-colored in polynomial time, such that any homothet of T that contains at least m_t points contains points of both colors.*

This paper is organized as follows. In Section 2 we introduce definitions, notations, tools and some useful lemmas. In Section 3 we describe a generalized 2-coloring algorithm and then apply it for parallelograms and for triangles. Concluding remarks and open problems appear in Section 4. Due to space limitations, some proofs are omitted and can be found in the full version of this extended abstract.

2 Preliminaries

Unless stated otherwise, we restrict ourselves to the two-dimensional Euclidean space \mathbb{R}^2 . For a point $p \in \mathbb{R}^2$ let $(p)_x$ and $(p)_y$ denote the x - and y -coordinate of p , respectively. We denote by ∂S the boundary of a subset $S \subseteq \mathbb{R}^2$ and by $Cl(S)$ the closure of S . A *homothet* of S is a translated and scaled copy of S . That is, a set $S' = \alpha S + p$ for some number $\alpha > 0$ and a point $p \in \mathbb{R}^2$.

► **Lemma 6** (e.g., [21]). *Let C be a convex and compact set and let C_1 and C_2 be homothets of C . Then if ∂C_1 and ∂C_2 intersect finitely many times, then they intersect in at most two points.*

2.1 Generalized Delaunay triangulations

For proving Theorems 3 and 5 we will use the notion of generalized Delaunay triangulations, which are the dual of generalized Voronoi diagrams. In the generalized Delaunay triangulation of a point set \mathcal{S} with respect to some convex set C , two points of \mathcal{S} are connected by a straight-line edge if there is a homothet of C that contains them and does not contain any other point of \mathcal{S} in its interior. The generalized Delaunay triangulation of \mathcal{S} with respect to C is denoted by $\mathcal{DT}(C, \mathcal{S})$. We say that \mathcal{S} is *in general position* with respect to (homothets of) C , if there is no homothet of C whose boundary contains four points from \mathcal{S} . If \mathcal{S} is in general position with respect to a convex polygon P and no two points of \mathcal{S} define a line that is parallel to a line through two vertices of P , then we say that \mathcal{S} is in *very general position* with respect to P . The following properties of generalized Delaunay triangulations will be useful.

► **Lemma 7** ([4, 19, 34]). *Let C be a convex set and let \mathcal{S} be a set of points in general position with respect to C . Then $\mathcal{DT}(C, \mathcal{S})$ is a well-defined connected plane graph whose inner faces are triangles.*

It would be convenient to consider generalized Delaunay triangulations in which the boundary of the outer face is a convex polygon. In such a case we say that $\mathcal{DT}(C, \mathcal{S})$ is *nice*.

► **Lemma 8.** *Let P be a closed convex polygon and let \mathcal{S} be a set of points in the plane that is in very general position with respect to P . Suppose that P' is a homothet of P and $Z \subseteq \mathcal{S} \cap \partial P'$. Then there is a homothet of P , denote it by P'' , such that $P'' \cap \mathcal{S} = (P' \cap \mathcal{S}) \setminus Z$.*

For a homothet C' of a convex set C we denote by $\mathcal{DT}(C, \mathcal{S})[C']$ the subgraph of $\mathcal{DT}(C, \mathcal{S})$ that is induced by the points of $\mathcal{S} \cap C'$. Note that it is not the same as $\mathcal{DT}(C, \mathcal{S} \cap C')$, however the following is true.

► **Lemma 9.** *Let P be a closed convex polygon, let \mathcal{S} be a set of points in very general position with respect to P , and let P' be a homothet of P . Then $\mathcal{DT}(P, \mathcal{S})[P']$ is a connected graph that is contained in P' .*

► **Corollary 10.** *Let P be a closed convex polygon and let \mathcal{S} be a set of points in very general position with respect to P . Suppose that P' is a homothet of P and e is an edge of $\mathcal{DT}(P, \mathcal{S})$ that crosses $\partial P'$ twice and thus splits P' into two parts. Then one of these parts does not contain a point from \mathcal{S} .*

A *rotation* of a vertex v in a plane graph G is the clockwise order of its neighbors. For three straight-line edges vx, vy, vz we say that vy is *between* vx and vz if x, y, z appear in this order in the rotation of v and $\angle xvy < \pi$ ($\angle xvy$ is the angle by which one has to rotate the vector \vec{vx} around v clockwise until its direction coincides with that of \vec{vz}). The following will be useful later on.

► **Proposition 11.** *Let C be a convex set and let \mathcal{S} be a set of points such that $\mathcal{DT} := \mathcal{DT}(C, \mathcal{S})$ is nice. Let C' be a homothet of C and let v be a vertex in $\mathcal{DT}[C']$. Suppose that x and z are two vertices such that z immediately follows x in the rotation of v in $\mathcal{DT}[C']$, $\angle xvy < \pi$ and $xz \notin \mathcal{DT}$. Then there exists an edge $vy \in \mathcal{DT}$ between vx and vz (which implies that $y \notin C'$).*

Proof. Suppose that x and z are also consecutive in the rotation of v in \mathcal{DT} . Then the face that is incident to vx and vz and is to the right of \vec{vx} and to the left of \vec{vz} cannot be the outer face since $\angle xvy < \pi$ and \mathcal{DT} is nice. However, since this face is an inner face, then by Lemma 7 it must be a triangle and so $xz \in \mathcal{DT}$. ◀

2.2 Self-coverability of convex polygons and polychromatic k -coloring

Keszegh and Pálvölgyi introduced in [16] the notion of *self-coverability* and its connection to polychromatic k -coloring. In this section we list the definition and results from their work that we use.

► **Definition 12** ([16]). A collection of closed sets \mathcal{F} in a topological space is *self-coverable* if there exists a *self-coverability function* f such that for any set $F \in \mathcal{F}$ and for any finite point set $\mathcal{S} \subset F$, with $|\mathcal{S}| = l$ there exists a subcollection $\mathcal{F}' \subset \mathcal{F}$, $|\mathcal{F}'| \leq f(l)$ such that $\bigcup_{F' \in \mathcal{F}'} F' = F$ and no point of \mathcal{S} is in the interior of some $F' \in \mathcal{F}'$.

► **Theorem 13** ([16]). *For every convex polygon P there is a constant $c_f := c_f(P)$ such that the family of all homothets of P is self-coverable with $f(l) \leq c_f l$.*

► **Theorem 14** ([16]). *The family of all homothets of a square is self-coverable with $f(l) := 2l + 2$ and this is sharp.*

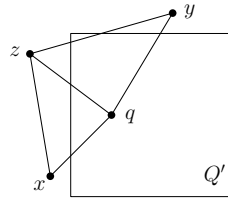

■ **Figure 1** Considering homothets of an axis-parallel square, $x-q-y$ is a good 2-path whereas $x-q-z$ is not since the square Q' separates it and both qx and qz cross the left side of Q' .

► **Theorem 15** ([16]). *The family of all homothets of a given triangle is self-coverable with $f(l) := 2l + 1$ and this is sharp.*

► **Theorem 16** ([16, Theorem 2]). *If \mathcal{F} is self-coverable with a monotone self-coverability function $f(l) > l$ and any finite set of points can be colored with two colors such that any member of \mathcal{F} with at least m points contains both colors, then any finite set of points can be colored with k colors such that any member of \mathcal{F} with at least $m_k := m(f(m-1))^{\lceil \log k \rceil - 1} \leq k^d$ points contains all k colors (where d is a constant that depends only on \mathcal{F}).*

Theorems 3 and 16 immediately imply Corollary 4.

3 A 2-coloring algorithm

In this section we prove Theorems 3 and 5. In fact, we prove a more general result, for which we need the following definitions.

► **Definition 17** (Good paths and good homothets). Let P be an (open or closed) convex polygon, let \mathcal{S} be a finite set of points, let $\mathcal{DT} := \mathcal{DT}(P, \mathcal{S})$, and let P' be a homothet of P .

- Let $x-y-z$ be a 2-path in \mathcal{DT} (i.e., a simple path of length two). If P' contains y and does not contain x and z , then we say that it *separates* the 2-path $x-y-z$.
- A 2-path $x-y-z$ is *good*, if there is no homothet of P that separates it such that the edges yx and yz cross the same side of this homothet of P (see Figure 1 for an example).
- A 3-path $x-y-z-w$ in \mathcal{DT} is *good* if both $x-y-z$ and $y-z-w$ are good 2-paths.
- P' is *good* if it contains a good 3-path or $\mathcal{DT}[P']$ contains a cycle.

► **Definition 18** (Universally good polygons). We say that an (open or closed) polygon P is *universally good* with a constant $c_g := c_g(P)$ if for any finite set of points \mathcal{S} such that \mathcal{S} is in very general position with respect to P and $\mathcal{DT}(P, \mathcal{S})$ is nice, every homothet of P that contains at least c_g points from \mathcal{S} is good.

► **Theorem 19.** *Let P be an (open or closed) convex polygon with n vertices such that P is a universally good polygon with a constant $c_g := c_g(P)$, and let $f(l) \leq c_f l$ be a self-coverability function of the family of homothets of $Cl(P)$ (where c_f is a constant). Then there is a constant $m := m(P) \leq c_g f(n) + n$ such that it is possible to 2-color in polynomial time the points of any given finite set of points \mathcal{S} such that every homothet of P that contains at least m points from \mathcal{S} contains points of both colors.*

Theorems 3 and 5 immediately follow from Theorems 14, 15, 19, and the following.

► **Lemma 20.** *Every triangle is a universally good polygon with a constant $c_g \leq 7382$.*

► **Lemma 21.** *Every parallelogram is a universally good polygon with a constant $c_g \leq 148$.*

3.1 Proof of Theorem 19

Let P be an (open or closed) convex polygon with n vertices such that P is a universally good polygon with a constant $c_g := c_g(P)$, and let $f(l) \leq c_f l$ be a self-coverability function of the family of homothets of $Cl(P)$ (where c_f is a constant). Set $m := c_g f(n) + n$. We first argue that it is enough to prove Theorem 19 when P is a closed polygon. Indeed, suppose that P is open, let \mathcal{P} be the family of homothets of P and let $\mathcal{P}_0 \subseteq \mathcal{P}$ be a finite subfamily that realizes $H^{\mathcal{P}}(\mathcal{S})$. By slightly shrinking every homothet of P in \mathcal{P}_0 with respect to an interior point, we get a subfamily $\mathcal{P}'_0 \subseteq \mathcal{P}$ that realizes $H^{\mathcal{P}}(\mathcal{S})$ such that there is no $p \in \mathcal{S}$ and $P' \in \mathcal{P}'_0$ with $p \in \partial P'$. Let $\bar{P} := Cl(P)$ be the closed polygon that is the closure of P . Note that by definition \bar{P} is universally good with the same constant c_g and is self-coverable with the same self-coverability function. Let $\bar{\mathcal{P}}$ be the family of homothets of \bar{P} , and let $\bar{\mathcal{P}}'_0 \subseteq \bar{\mathcal{P}} := \{Cl(P') \mid P' \in \mathcal{P}'_0\}$. Since there is no homothet of P in \mathcal{P}'_0 that contains a point of \mathcal{S} on its boundary, every hyperedge of $H^{\mathcal{P}}(\mathcal{S})$ appears also in $H^{\bar{\mathcal{P}}}(\mathcal{S})$. Thus, it is enough to show that $\bar{\mathcal{P}}$ satisfies Theorem 19.

Suppose therefore that P is a closed convex polygon. Let \mathcal{P} be the family of homothets of P and let $\mathcal{P}_0 \subseteq \mathcal{P}$ be the smallest subfamily that realizes $H^{\mathcal{P}}(\mathcal{S})$. For convenience we pick \mathcal{P}_0 such that every $P' \in \mathcal{P}_0$ is minimal in the sense that it does not contain any other homothet of P that contains the same set of points from \mathcal{S} . We may also assume that \mathcal{S} is in very general position with respect to P . Indeed, otherwise note that a small perturbation of the points will achieve that and observe also that for every homothet $P' \in \mathcal{P}_0$ a slightly inflated P' will contain the (perturbed) points that correspond to the points in $\mathcal{S} \cap P'$ and no other points. After a perturbation every homothet in \mathcal{P}_0 is ‘almost’ minimal, which is fine for our purposes. It will also be convenient to assume that after the perturbation, the boundaries of every two polygons in \mathcal{P}_0 do not overlap, and no edge in $\mathcal{DT} := \mathcal{DT}(P, \mathcal{S})$ crosses the boundary of a polygon in \mathcal{P}_0 at one of its vertices. It follows from Lemma 6 that \mathcal{P}_0 is a family of *pseudo-disks*.² This implies that $|\mathcal{P}_0| = O(|\mathcal{S}|^3)$ by a result of Buzaglo et al. [5] who proved the following: Suppose that $(\mathcal{V}, \mathcal{E})$ is a hypergraph where \mathcal{V} is a set of points in the plane and for every hyperedge $e \in \mathcal{E}$ there is a region bounded by a simple closed curve that contains the points of e and no other points from \mathcal{V} . If all the regions that correspond to \mathcal{E} define a family of pseudo-disks, then $|\mathcal{E}| = O(|\mathcal{V}|^3)$.

We can also assume that \mathcal{DT} is nice, that is, the boundary of its outer face is a convex polygon: Set $-P := \{(-x, -y) \mid (x, y) \in P\}$ and let $-P'$ be a homothet of $-P$ that contains in its interior all the polygons in \mathcal{P}_0 . By adding the vertices of $-P'$ to \mathcal{S} (and perturbing again if needed) we obtain a set of points such that $-P'$ is the boundary of the outer face in its generalized Delaunay triangulation with respect to P . Moreover, we have only extended the set of point subsets \mathcal{S}' that contain at least m points and for which there is a homothet $P' \in \mathcal{P}_0$ such that $\mathcal{S}' \cap P' = \mathcal{S}'$. Therefore a valid 2-coloring of the new set of points induces a valid 2-coloring of the original set of points.

Recall that \mathcal{DT} is a plane graph, and therefore, by the Four Color Theorem, we can color the points in \mathcal{S} with four colors, say 1, 2, 3, 4, such that there are no adjacent vertices in \mathcal{DT} with the same color. In order to obtain two color classes, we recolor all the vertices of colors 1 or 2 with the color *light red* and all the vertices of colors 3 or 4 with the color *light blue*.

Call a homothet $P' \in \mathcal{P}_0$ *heavy monochromatic* if it contains exactly c_g points from \mathcal{S} and all of them are of the same color. If all of these points are colored light blue (resp., red), then P' a heavy light blue (resp., red) homothet. Obviously, if there are no heavy monochromatic

² In a family of pseudo-disks the boundaries of every two regions cross at most twice.

homothets, then we are done since $m > c_g$ and by Lemma 8 a monochromatic homothet with $m > c_g$ points from \mathcal{S} can be shrunk to a monochromatic homothet with exactly c_g points from \mathcal{S} . Suppose that P' is a heavy monochromatic homothet of P . Observe that $\mathcal{DT}[P']$ is a tree, for otherwise it would contain a cycle which in turn would contain a triangle by Lemma 7. That triangle must be 3-colored in the initial 4-coloring, so not all of its points can be light red or light blue, contradicting the monochromaticity of the points in P' .

Since P is universally good, P' contains c_g points and $\mathcal{DT}[P']$ is a tree, it follows that P' contains a good 3-path $x-y-z-w$. We associate this 3-path with P' . Suppose that P' is a heavy light red homothet of P . Then one of y and z was originally colored 1 and the other was originally colored 2. Recolor the one whose original color was 1 with the color *dark blue*. Similarly, if P' is a heavy light blue homothet of P , then one of y and z was originally colored 3 and the other was originally colored 4. In this case we recolor the one whose original color was 3 with the color *dark red*. Repeat this for every heavy monochromatic homothet, and, finally, in order to obtain a 2-coloring, merge the color classes light red and dark red into one color class – red, and merge the color classes light blue and dark blue into one color class – blue.

► **Lemma 22.** *There is no homothet $P' \in \mathcal{P}_0$ that contains m points from \mathcal{S} all of which of the same color.*

Proof. Suppose for contradiction that P' is a homothet of P that contains m points from \mathcal{S} all of which of the same color. We may assume without loss of generality that all the points in P' are colored red, therefore, before the final recoloring each point in P' was either light red or dark red. Recall that n is the number of vertices of P . We consider two cases based on the number of dark red points in P' .

Case 1: There are at most n dark red points in P'

By Theorem 13 there is a set \mathcal{P}' of at most $f(n)$ homothets of P whose union is P' such that no dark red point in P' is in the interior of one of these homothets. Using Lemma 8 we can change these homothets slightly such that none of them contains a dark red point yet all light red points are still covered by these homothets. Thus the at least $m - n = c_g f(n)$ light red points are covered by these at most $f(n)$ homothets. By the pigeonhole principle one of these homothets, denote it by P'' , contains at least $\frac{c_g f(n)}{f(n)} = c_g$ light red points and no other points. However, in this case it follows from Lemma 8 that there is a heavy light red homothet in \mathcal{P}_0 that contains exactly c_g points from $\mathcal{S} \cap P''$. Therefore, the coloring algorithm should have found within this heavy light red homothet a good 3-path and recolored one of its vertices with dark blue and then blue. This contradicts the assumption that all the points in P' are red.

Case 2: There are more than n dark red points in P'

Let y be one of these dark red points. Then there is a good 3-path $x-y-z-w$ within a heavy light blue homothet $P_y \in \mathcal{P}_0$ with whom this 3-path is associated. Furthermore, the original color of y is 3 and therefore the original color of x and z is 4, and thus their final color is blue. It follows that P' separates $x-y-z$, moreover, since $x-y-z$ is a good 2-path, the edges yx and yz cross different sides of P' . Let s_x (resp., s_z) be the side of P' that is crossed by yx (resp., yz), and let q_x (resp., q_z) be the crossing point of yx and s_x (resp., yz and s_z). See Figure 2.

Note that $\partial P'$ and ∂P_y cross each other exactly twice. Indeed, this follows from Lemma 6 and the fact that there are points from \mathcal{S} in each of $P' \cap P_y$ (e.g., y), $P_y \setminus P'$ (e.g., x and z)

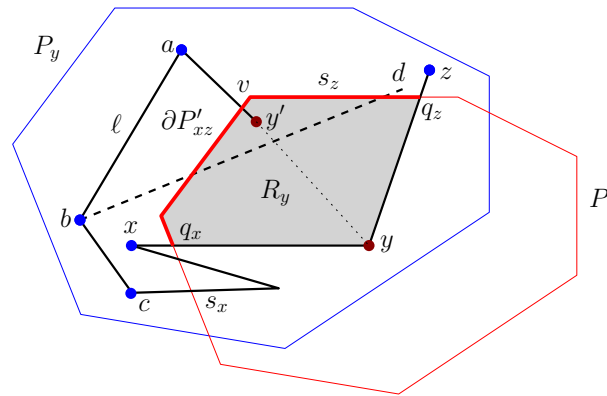

■ **Figure 2** An illustration for the proof of Lemma 22.

and $P' \setminus P_y$ (since $|P' \cap \mathcal{S}| \geq m > c_g = |P_y \cap \mathcal{S}|$). The points q_x and q_z partition $\partial P'$ into two parts $\partial P'_1$ and $\partial P'_2$. Note that since $q_x, q_z \in P' \cap P_y$, the two crossing points between $\partial P'$ and ∂P_y must lie either in $\partial P'_1$ or in $\partial P'_2$. Assume without loss of generality that both of them lie in $\partial P'_1$. Thus $\partial P'_2 \subset P_y$. Let v be a vertex of P' in $\partial P'_2$ (note that since $s_x \neq s_z$ each of $\partial P'_1$ and $\partial P'_2$ contains a vertex of P'). We associate the vertex v with the dark red point y . We also define R_y to be the region whose boundary consists of the segment yq_x of yx , the segment yq_z of yz , and the part of $\partial P'_2$ whose endpoints are q_x and q_z (call this part $\partial P'_{xz}$). Observe that $R_y \subseteq P' \cap P_y$.

► **Proposition 23.** *There is no other point but y in $\mathcal{S} \cap R_y$.*

Proof. Suppose that the claim is false and let $y' \in \mathcal{S} \cap R_y$ be another point in R_y . As y' is in P' , it must be red after the final coloring. Also, as it is also in P_y , it must be a dark red point (which was light blue before having been recolored to dark red and finally to red). Thus, y' is a dark red point in R_y .

Since x and y' both lie in the heavy light blue homothet P_y , they are connected by a path in $\mathcal{DT}[P_y]$ that alternates between points of colors 3 and 4 (considering the initial 4-coloring). We may assume without loss of generality that y' is the first point in R_y along this path from x to y' : indeed, there are no points of color 4 in R_y , and if there is point of color 3 before y' , then we can name it y' . Denote by ℓ the path (in \mathcal{DT}) from y to y' that consists of the edge yx and the above-mentioned path from x to y' . Consider the polygon \hat{P} whose boundary consists of ℓ and a straight-line segment yy' (\hat{P} is not a homothet of P). Since y' and y are the only vertices of \hat{P} in R_y , there is no edge of ℓ that crosses yy' . Indeed, if there was such an edge then it would split P' into two parts such that one contains y and the other contains y' . This would contradict Corollary 10. Hence \hat{P} is a simple polygon.

Since every simple polygon has at least three convex vertices, \hat{P} has a convex vertex different from y and y' (thus this vertex is not in R_y). Denote this vertex by b and let a and c be its neighbors along ℓ such that $\angle abc < \pi$. Observe that since $\angle abc < \pi$ it is impossible that the outer face of \mathcal{DT} is incident to a, b, c and lies inside \hat{P} . Therefore, since the initial color of a and c is the same (thus $ac \notin \mathcal{DT}$), it follows from Proposition 11 that there is a neighbor d of b in \mathcal{DT} in between a and c . Furthermore, it is not hard to see that there is such a neighbor d whose initial color is 1 or 2. Note that $\hat{P} \subseteq P_y$ since all of its edges are inside P_y . Thus $d \notin \hat{P}$ and also $d \notin P_y$ since P_y does not contain vertices of color 1 or 2. Now consider the directed edge bd : it starts inside \hat{P} (since d is in between a and c) and so it must cross yy' . Before doing so bd must cross ∂R_y and so it crosses $\partial P'_{xz}$, since it cannot cross yq_z

5:10 Coloring Points with Respect to Squares

or yq_x . After crossing yy' , the directed edge bd must cross $\partial P'_{xz}$ again, since $d \notin R_y$. But then bd splits P' into two parts such that one contains y and the other contains y' , which is impossible by Corollary 10. ◀

In a similar way to the one described above, we associate a vertex of P' with every dark red point in P' . Since there are more than n dark red points in P' , there are two of them, denote them by y and y' , that are associated with the same vertex of P' , denote it by v . Let $x-y-z$ (resp., $x'-y'-z'$) be the good 2-path that corresponds to y (resp., y') as above. Let yq_x and yq_z (resp., $yq_{x'}$ and $yq_{z'}$) be the edge-segments of yx and yz (resp., $y'x'$ and $y'z'$) as above, and let R_y (resp., $R_{y'}$) be the region as defined above.

It follows from Proposition 23 that $y \notin R_{y'}$ and $y' \notin R_y$. However, ∂R_y and $\partial R_{y'}$ both contain v . This implies that one of the segments yq_x and yq_z crosses one of the segments $y'q_{x'}$ and $y'q_{z'}$, which is impossible since these are segments of edges of a plane graph. Lemma 22 is proved. ◀

To complete the proof of Theorem 19, we need to argue that the described algorithm runs in polynomial time. Indeed, constructing the generalized Delaunay triangulation and then 4-coloring it can be done in polynomial time. Recall that there are at most $O(|\mathcal{S}|^3)$ combinatorially different homothets of P . Among them, we need to consider those that contain exactly c_g points, and for each such heavy monochromatic homothet P' we need to find a good 3-path in $\mathcal{DT}[P']$, for the final recoloring step. This takes a constant time for every heavy monochromatic homothet, since c_g is a constant. Therefore, the overall running time is polynomial with respect to the size of \mathcal{S} . ◀

3.2 Parallelograms are universally good

In this section we prove Lemma 21. Let Q be a parallelogram, let \mathcal{S} be a set of points in very general position with respect to Q , and let $\mathcal{DT} := \mathcal{DT}(Q, \mathcal{S})$ be the generalized Delaunay triangulation of \mathcal{S} with respect to Q such that \mathcal{DT} is nice (i.e., the boundary of its outer face is a convex polygon). By applying an affine transformation, we may assume without loss of generality that Q is an axis-parallel square. Since \mathcal{S} is in very general position, no two points in \mathcal{S} share the same x - or y -coordinate.

Suppose that Q' is a homothet of Q that contains at least 148 points from \mathcal{S} and that $\mathcal{DT}[Q']$ is a tree. We will show that Q' contains a good 3-path.

Let $q \in \mathcal{S}$ be a point. We partition the points of the plane into four open quadrants according to their position with respect to q : $\text{NE}(q)$ (North-East), $\text{NW}(q)$ (North-West), $\text{SE}(q)$ (South-East), and $\text{SW}(q)$ (South-West).

► **Proposition 24.** *For every point $q \in \mathcal{S} \cap Q'$ there are no two neighbors of q in $\mathcal{DT}[Q']$ that lie in the same quadrant of q .*

► **Proposition 25.** *Let x and y be two neighbors of q in $\mathcal{DT}[Q']$. Let $z \notin Q'$ be a neighbor of q in \mathcal{DT} that lies between x and y in the rotation of q and let Q_z be a square that contains q and z and no other point from \mathcal{S} . Then:*

- *if $x \in \text{NW}(q)$ and $y \in \text{NE}(q)$, then qz crosses the top side of Q' , x is to the left of Q_z and y is to the right of Q_z ;*
- *if $x \in \text{NE}(q)$ and $y \in \text{SE}(q)$, then qz crosses the right side of Q' , x is above Q_z and y is below Q_z ;*
- *if $x \in \text{SE}(q)$ and $y \in \text{SW}(q)$, then qz crosses the bottom side of Q' , x is to the right of Q_z and y is to the left of Q_z ; and*

- if $x \in \text{SW}(q)$ and $y \in \text{NW}(q)$, then qz crosses the left side of Q' , x is below Q_z and y is above Q_z .

Call a (simple) path in \mathcal{DT} x -monotone (resp., y -monotone) if there is no vertical (resp., horizontal) line that intersects the path in more than one point.

► **Proposition 26.** *Every path in $\mathcal{DT}[Q']$ is x -monotone or y -monotone.*

Proof. Suppose for contradiction that there is a path $p := q_1-q_2-\dots-q_k$ which is neither x -monotone nor y -monotone. Since p is a polygonal path, it follows that there are two points, q_i and q_j , that are “witnesses” to the non- x - and non- y -monotonicity of p , respectively. That is, both q_{i-1} and q_{i+1} are to the left of q_i or both of them are to its right, and both q_{j-1} and q_{j+1} are above q_j or both of them are below q_j . We choose i and j such that $|i - j|$ is minimized, and assume without loss of generality that $i < j$ (note that it follows from Proposition 24 that $i \neq j$). Thus, the sub-path $p' := q_i-q_{i+1}-\dots-q_{j-1}-q_j$ is both x -monotone and y -monotone.

By reflecting about the x - and/or y -axis if needed, we may assume that p' is ascending, that is, for every $l = i, \dots, j - 1$ we have $q_{l+1} \in \text{NE}(q_l)$. Then it follows from Proposition 24 that $q_{i-1} \in \text{SE}(q_i)$ and $q_{j+1} \in \text{SE}(q_j)$. By Proposition 11 there is a point $x \notin Q'$ which is a neighbor of q_i and is between q_{i-1} and q_{i+1} in the rotation of q_i , and it follows from Proposition 25 that $q_i x$ crosses the right side of Q' . The same argument implies that there is a point $y \notin Q'$ which is a neighbor of q_j and is between q_{j+1} and q_{j-1} in the rotation of q_j , such that $q_j y$ crosses the bottom side of Q' . However, since q_j is to the right of q_i and above it, the edges $q_i x$ and $q_j y$ must cross, which is impossible. ◀

Call a 2-path w - q - z *bad* if it is not good, that is, there is an axis-parallel square Q'' that contains q , does not contain w and z , and qw and qz are edges in \mathcal{DT} that cross the same side of Q'' . We say that w - q - z is a *bad left* 2-path if qw and qz cross the left side of Q'' , and define *right*, *top*, and *bottom* bad 2-paths analogously.

► **Proposition 27.** *Let w - q - z be a 2-path. Then:*

- w - q - z is a bad left 2-path iff $w \in \text{SW}(q)$ and $z \in \text{NW}(q)$, or vice versa;
- w - q - z is a bad right 2-path iff $w \in \text{SE}(q)$ and $z \in \text{NE}(q)$, or vice versa;
- w - q - z is a bad top 2-path iff $w \in \text{NW}(q)$ and $z \in \text{NE}(q)$, or vice versa; and
- w - q - z is a bad bottom 2-path iff $w \in \text{SW}(q)$ and $z \in \text{SE}(q)$, or vice versa.

► **Proposition 28.** *Every path in $\mathcal{DT}[Q']$ contains at most four bad 2-paths.*

Proof. Let $p := q_1-q_2-\dots-q_k$ be a simple path in $\mathcal{DT}[Q']$ and suppose for a contradiction that p contains at least five bad 2-paths. By Proposition 26 the path p is x -monotone or y -monotone. Assume without loss of generality that p is y -monotone and that it goes upwards, that is, q_{i+1} is above q_i for every $i = 1, 2, \dots, k - 1$. It follows that p does not contain bad top or bad bottom 2-paths, for otherwise it would not be y -monotone. It is not hard to see that bad left and bad right 2-paths must alternate along p , that is, between every two bad left 2-paths there is a bad right 2-path and vice versa.

Consider the first five such bad 2-paths along the path p , and denote them by $q_{i_1-1}-q_{i_1}-q_{i_1+1}$, $q_{i_2-1}-q_{i_2}-q_{i_2+1}$, $q_{i_3-1}-q_{i_3}-q_{i_3+1}$, $q_{i_4-1}-q_{i_4}-q_{i_4+1}$ and $q_{i_5-1}-q_{i_5}-q_{i_5+1}$. By symmetry we may assume without loss of generality that $q_{i_1-1}-q_{i_1}-q_{i_1+1}$ is a bad left 2-path, and therefore $q_{i_3-1}-q_{i_3}-q_{i_3+1}$ and $q_{i_5-1}-q_{i_5}-q_{i_5+1}$ are also bad left 2-paths, whereas the 2-paths $q_{i_2-1}-q_{i_2}-q_{i_2+1}$ and $q_{i_4-1}-q_{i_4}-q_{i_4+1}$ are bad right.

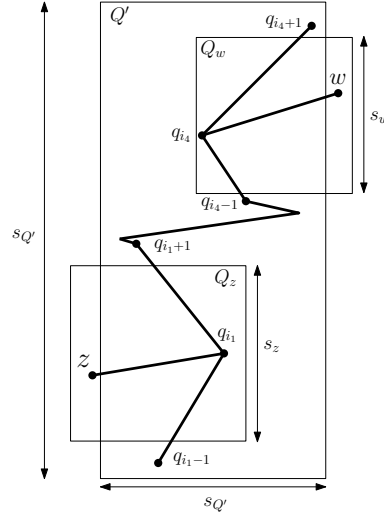

■ **Figure 3** An illustration for the proof of Proposition 28.

Note that we may assume without loss of generality that q_{i_1} is to the right of q_{i_4} , for otherwise q_{i_5} must be to the right of q_{i_2} and by reflecting about the x -axis and renaming the points we get the desired assumption. By Proposition 11, q_{i_1} has a neighbor $z \notin Q'$ between q_{i_1-1} and q_{i_1+1} in the rotation of q_{i_1} . Let Q_z be a square that contains q_{i_1} and z and no other point from \mathcal{S} and let s_z be its side length (refer to Figure 3).

It follows from Proposition 25 that q_{i_1-1} lies below Q_z , q_{i_1+1} lies above Q_z , and z lies to the left of Q' . Therefore, $(q_{i_1+1})_y - (q_{i_1-1})_y > s_z$. Similarly, q_{i_4} has a neighbor $w \notin Q'$ between q_{i_4+1} and q_{i_4-1} in the rotation of q_{i_4} . Let Q_w be a square that contains q_{i_4} and w and no other point from \mathcal{S} and let s_w be its side length. Then q_{i_4-1} lies below Q_w , q_{i_4+1} lies above Q_w , and w lies to the right of Q' . Therefore, $(q_{i_4+1})_y - (q_{i_4-1})_y > s_w$.

Note that since q_{i_1} is to the right of q_{i_4} and z and w are to the left and to the right of Q' , respectively, we have $s_z + s_w > ((q_{i_1})_x - (z)_x) + ((w)_x - (q_{i_4})_x) > s_{Q'}$, where $s_{Q'}$ is the side length of Q' . Observe also that since there are at least two other vertices between q_{i_1} and q_{i_4} along p , we have that $q_{i_1+1} \neq q_{i_4-1}$, and thus q_{i_1+1} lies below q_{i_4-1} . This implies that $((q_{i_1+1})_y - (q_{i_1-1})_y) + ((q_{i_4+1})_y - (q_{i_4-1})_y) < s_{Q'}$. Combining the inequalities we get, $s_{Q'} > ((q_{i_1+1})_y - (q_{i_1-1})_y) + ((q_{i_4+1})_y - (q_{i_4-1})_y) > s_z + s_w > ((q_{i_1})_x - (z)_x) + ((w)_x - (q_{i_4})_x) > s_{Q'}$, a contradiction. ◀

To complete the proof of Lemma 21 we will consider a path of length 11 in $\mathcal{DT}[Q']$. It follows from Proposition 24 that for every $q \in \mathcal{S} \cap Q'$ we have $\deg_{\mathcal{DT}[Q']}(q) \leq 4$. This implies that if Q' contains at least $1 + \sum_{i=1}^5 4^i = 1366$ points from \mathcal{S} then $\mathcal{DT}[Q']$ contains a simple path of length at least 11. However, one can show that already 148 points suffice to guarantee the existence of a path of length 11. The proof of this can be found in the full version of this paper.

Let $p := q_1 - q_2 - \dots - q_{12}$ be a simple path of length 11 in $\mathcal{DT}[Q']$. By Proposition 28 there are at most four bad 2-paths $q_{i-1} - q_i - q_{i+1}$ in p . Therefore, there is $2 \leq i \leq 10$ such that $q_{i-1} - q_i - q_{i+1}$ and $q_i - q_{i+1} - q_{i+2}$ are good 2-paths, and therefore Q contains a good 3-path $q_{i-1} - q_i - q_{i+1} - q_{i+2}$. Lemma 21 is proved. ◀

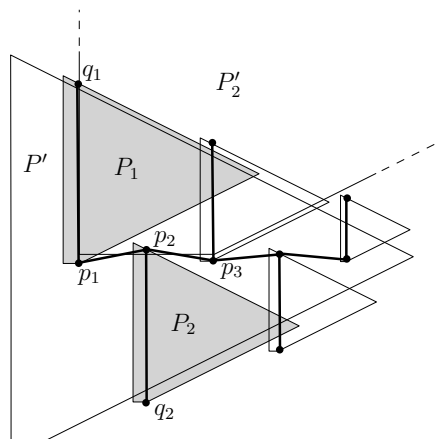

■ **Figure 4** a convex quadrilateral that is not universally good.

4 Discussion

We have presented a general framework showing that if a convex polygon P satisfies a certain property (namely, is *universally good* as defined in Section 3.1), then there is an absolute constant m that depends only on P such that every set of points in the plane can be 2-colored such that every homothet of P that contains at least m points contains points of both colors.

We then used this framework for 2-coloring points with respect to squares, showing that one can 2-color any set of points in the plane such that every square that contains at least 1484 points from the point set contains points of both colors. It would be interesting to improve this constant, as it is most likely not the best possible, and any such improvement would also improve the bound for polychromatic colorings (Corollary 4). The results for squares apply also for homothets of any given parallelogram by affine transformations. The main open problem related to our work is the following.

► **Problem 29.** *Is it true that for every convex polygon P there is a constant $m := m(P)$ such that it is possible to 2-color any set of points \mathcal{S} such that every homothet of P that contains at least m points from \mathcal{S} contains points of both colors?*

By Theorem 19 it would be enough to show that every convex polygon is universally good. In the full version of this paper we have demonstrated that any triangle is universally good, and thus provided a new proof for the known positive answer to Problem 29 for triangles. However, for other classes of convex polygons it seems that additional ideas are needed, in light of the following.

► **Lemma 30.**

1. *For every integer $n \geq 4$ there exists a convex polygon with n vertices that is not universally good.*
2. *For every even integer $n \geq 6$ there exists a centrally-symmetric convex polygon with n vertices that is not universally good.*

Figure 4 describes the construction that we use to prove the first part of Lemma 30.

We conclude with two interesting related open problems. Considering coloring of points with respect to disks, recall that Pálvölgyi [32] recently proved that there is no constant m such that any set of points in the plane can be 2-colored such that any (unit) disk that

contains at least m points from the given set is non-monochromatic (that is, contains points of both colors). Coloring the points with four colors such that any disk that contains at least two points is non-monochromatic is easy since the (generalized) Delaunay graph is planar. Therefore, it remains an interesting open problem whether there is a constant m such that any set of points in the plane can be 3-colored such that any disk that contains at least m points is non-monochromatic.

Perhaps the most interesting and challenging problem of coloring geometric hypergraphs is to color a planar set of points \mathcal{S} with the minimum possible number of colors, such that every axis-parallel rectangle that contains at least two points from \mathcal{S} is non-monochromatic. It is known that $\Omega(\log(|\mathcal{S}|)/\log^2 \log(|\mathcal{S}|))$ colors are sometimes needed [11], and it is conjectured that $\text{polylog}(|\mathcal{S}|)$ colors always suffice. The latter holds when considering rectangles that contain at least three points [1], however, for the original question only polynomial upper bounds are known [2, 10, 13, 29].

References

- 1 Eyal Ackerman and Rom Pinchasi. On coloring points with respect to rectangles. *J. Comb. Theory, Ser. A*, 120(4):811–815, 2013. doi:10.1016/j.jcta.2013.01.005.
- 2 Deepak Ajwani, Khaled M. Elbassioni, Sathish Govindarajan, and Saurabh Ray. Conflict-free coloring for rectangle ranges using $O(n^{382})$ colors. *Discrete & Computational Geometry*, 48(1):39–52, 2012. doi:10.1007/s00454-012-9425-5.
- 3 Greg Aloupis, Jean Cardinal, Sébastien Collette, Stefan Langerman, David Orden, and Pedro Ramos. Decomposition of multiple coverings into more parts. *Discrete & Computational Geometry*, 44(3):706–723, 2010. doi:10.1007/s00454-009-9238-3.
- 4 Prosenjit Bose, Paz Carmi, Sébastien Collette, and Michiel H. M. Smid. On the stretch factor of convex delaunay graphs. *JoCG*, 1(1):41–56, 2010. URL: <http://jocg.org/index.php/jocg/article/view/5>.
- 5 Sarit Buzaglo, Rom Pinchasi, and Günter Rote. Topological hypergraphs. In János Pach, editor, *Thirty Essays on Geometric Graph Theory*, pages 71–81. Springer New York, 2013. doi:10.1007/978-1-4614-0110-0_6.
- 6 Jean Cardinal, Kolja Knauer, Piotr Micek, and Torsten Ueckerdt. Making triangles colorful. *arXiv preprint arXiv:1212.2346*, 2012.
- 7 Jean Cardinal, Kolja Knauer, Piotr Micek, and Torsten Ueckerdt. Making octants colorful and related covering decomposition problems. *SIAM journal on discrete mathematics*, 28(4):1948–1959, 2014.
- 8 Jean Cardinal, Kolja B. Knauer, Piotr Micek, and Torsten Ueckerdt. Making triangles colorful. *J. of Computational Geometry*, 4(1):240–246, 2013. URL: <http://jocg.org/index.php/jocg/article/view/136>.
- 9 Jean Cardinal, Kolja B. Knauer, Piotr Micek, and Torsten Ueckerdt. Making octants colorful and related covering decomposition problems. *SIAM J. Discrete Math.*, 28(4):1948–1959, 2014. doi:10.1137/140955975.
- 10 Timothy M. Chan. Conflict-free coloring of points with respect to rectangles and approximation algorithms for discrete independent set. In Tamal K. Dey and Sue Whitesides, editors, *Symposium on Computational Geometry 2012, SoCG '12, Chapel Hill, NC, USA, June 17-20, 2012*, pages 293–302. ACM, 2012. doi:10.1145/2261250.2261293.
- 11 Xiaomin Chen, János Pach, Mario Szegedy, and Gábor Tardos. Delaunay graphs of point sets in the plane with respect to axis-parallel rectangles. *Random Struct. Algorithms*, 34(1):11–23, 2009. doi:10.1002/rsa.20246.

- 12 Matt Gibson and Kasturi Varadarajan. Optimally decomposing coverings with translates of a convex polygon. *Discrete & Computational Geometry*, 46(2):313–333, 2011. doi:10.1007/s00454-011-9353-9.
- 13 Sarel Har-Peled and Shakhar Smorodinsky. Conflict-free coloring of points and simple regions in the plane. *Discrete & Computational Geometry*, 34(1):47–70, 2005. doi:10.1007/s00454-005-1162-6.
- 14 Balázs Keszegh. Coloring half-planes and bottomless rectangles. *Computational Geometry*, 45(9):495–507, 2012.
- 15 Balázs Keszegh and Dömötör Pálvölgyi. Octants are cover-decomposable. *Discrete & Computational Geometry*, 47(3):598–609, 2012.
- 16 Balázs Keszegh and Dömötör Pálvölgyi. Convex polygons are self-coverable. *Discrete & Computational Geometry*, 51(4):885–895, 2014.
- 17 Balázs Keszegh and Dömötör Pálvölgyi. Octants are cover-decomposable into many coverings. *Computational Geometry*, 47(5):585–588, 2014.
- 18 Balázs Keszegh and Dömötör Pálvölgyi. More on decomposing coverings by octants. *Journal of Computational Geometry*, 6(1):300–315, 2015.
- 19 Rolf Klein. *Concrete and abstract Voronoi diagrams*, volume 400. Springer Science & Business Media, 1989.
- 20 István Kovács. Indecomposable coverings with homothetic polygons. *Discrete & Computational Geometry*, 53(4):817–824, 2015. doi:10.1007/s00454-015-9687-9.
- 21 L. Ma. *Bisectors and Voronoi Diagrams for Convex Distance Functions*. PhD thesis, FernUniversität Hagen, Germany, 2000.
- 22 János Pach. Decomposition of multiple packing and covering. In *2. Kolloquium über Diskrete Geometrie*, number DCG-CONF-2008-001, pages 169–178. Institut für Mathematik der Universität Salzburg, 1980.
- 23 János Pach. Covering the plane with convex polygons. *Discrete & Computational Geometry*, 1:73–81, 1986. doi:10.1007/BF02187684.
- 24 János Pach and Dömötör Pálvölgyi. Indecomposable coverings. In *Proc. 41st Int. Workshop on Graph-Theoretic Concepts in Computer Science (WG)*, to appear.
- 25 János Pach, Dömötör Pálvölgyi, and Géza Tóth. Survey on decomposition of multiple coverings. In Imre Bárány, Károly J. Böröczky, Gábor Fejes Tóth, and János Pach, editors, *Geometry — Intuitive, Discrete, and Convex*, volume 24 of *Bolyai Society Mathematical Studies*, pages 219–257. Springer Berlin Heidelberg, 2013.
- 26 János Pach and Gábor Tardos. Coloring axis-parallel rectangles. *Journal of Combinatorial Theory, Series A*, 117(6):776–782, 2010. doi:10.1016/j.jcta.2009.04.007.
- 27 János Pach, Gábor Tardos, and Géza Tóth. Indecomposable coverings. In Jin Akiyama, William Y. C. Chen, Mikio Kano, Xueliang Li, and Qinglin Yu, editors, *Discrete Geometry, Combinatorics and Graph Theory, 7th China-Japan Conference, CJCDCGT 2005, Tianjin, China, November 18-20, 2005, Xi'an, China, November 22-24, 2005, Revised Selected Papers*, volume 4381 of *Lecture Notes in Computer Science*, pages 135–148. Springer, 2005. doi:10.1007/978-3-540-70666-3_15.
- 28 János Pach, Gábor Tardos, and Géza Tóth. Indecomposable coverings. *Canadian mathematical bulletin*, 52(3):451–463, 2009.
- 29 János Pach and Géza Tóth. Conflict-free colorings. In Boris Aronov, Saugata Basu, János Pach, and Micha Sharir, editors, *Discrete and Computational Geometry*, volume 25 of *Algorithms and Combinatorics*, pages 665–671. Springer Berlin Heidelberg, 2003. doi:10.1007/978-3-642-55566-4_30.
- 30 János Pach and Géza Tóth. Decomposition of multiple coverings into many parts. *Comput. Geom.*, 42(2):127–133, 2009. doi:10.1016/j.comgeo.2008.08.002.

- 31 Dömötör Pálvölgyi. Indecomposable coverings with concave polygons. *Discrete & Computational Geometry*, 44(3):577–588, 2010. doi:10.1007/s00454-009-9194-y.
- 32 Dömötör Pálvölgyi. Indecomposable coverings with unit discs. *CoRR*, abs/1310.6900, 2013. URL: <http://arxiv.org/abs/1310.6900>.
- 33 Dömötör Pálvölgyi and Géza Tóth. Convex polygons are cover-decomposable. *Discrete & Computational Geometry*, 43(3):483–496, 2010. doi:10.1007/s00454-009-9133-y.
- 34 Deniz Sariöz. Generalized delaunay graphs with respect to any convex set are plane graphs. *CoRR*, abs/1012.4881, 2010. URL: <http://arxiv.org/abs/1012.4881>.
- 35 Shakhbar Smorodinsky. Conflict-free coloring and its applications. In Imre Bárány, Károly J. Böröczky, Gábor Fejes Tóth, and János Pach, editors, *Geometry — Intuitive, Discrete, and Convex*, volume 24 of *Bolyai Society Mathematical Studies*, pages 331–389. Springer Berlin Heidelberg, 2013. doi:10.1007/978-3-642-41498-5_12.
- 36 Shakhbar Smorodinsky and Yelena Yuditsky. Polychromatic coloring for half-planes. *Journal of Combinatorial Theory, Series A*, 119(1):146 – 154, 2012.
- 37 Gábor Tardos and Géza Tóth. Multiple coverings of the plane with triangles. *Discrete & Computational Geometry*, 38(2):443–450, 2007. doi:10.1007/s00454-007-1345-4.