

MU Guide

PUBLISHED BY UNIVERSITY EXTENSION, UNIVERSITY OF MISSOURI-COLUMBIA

Bait Stations for Controlling Rats and Mice

Robert A. Pierce II

Extension Fish and Wildlife Specialist, The School of Natural Resources

Controlling the damage caused by Norway rats (*Rattus norvegicus*) and house mice (*Mus musculus*) often involves the use of poison baits. Using bait stations in a rodent control program may increase the effectiveness and safety of rodent baits (rodenticides).

Bait stations are useful because they:

- Protect bait from moisture and dust, making the bait more acceptable to the target animal.
- Provide a protected place for rodents to feed, allowing them to feel more secure.
- Keep non-target animals (pets, livestock, desirable wildlife, etc.) and children away from bait that may be hazardous to them.
- Allow you to place bait in some locations where it would otherwise be difficult due to weather or potential hazards to non-target animals.
- Help prevent the accidental spilling of bait.
- Let you inspect bait easily to see if rodents are feeding.

Types of bait stations

Bait stations can be designed for rats or mice. They can also be designed to contain solid baits from grain or seed, liquid baits, or both.

Ready-made bait boxes may be purchased from commercial suppliers, or you may make them yourself. Manufactured bait boxes made of plastic, cardboard or metal are sold through hardware stores, farm supply stores, or to pest control companies (Figure 1). The University Extension center serving your county may know of local suppliers.

Bait boxes can also be built from scrap materials, and you can design homemade stations to fit your particular needs. Stations should be made out of solid materials that will not be easily knocked out of place or damaged.

Care should be taken to construct stations so that only rodents can reach the bait. Locks, seals or concealed latches are often used to make bait boxes more tamperproof. Clearly label all bait boxes or stations with "POISON," or "RODENT BAIT — DO NOT TOUCH," or with a similar warning.

Bait station design

It is important to design bait stations to allow several rodents to feed at once. They can be as simple as a flat board nailed at an angle to the bottom of a wall (Figure 2), or a length of pipe into which bait can be placed (Figure 3). More elaborate stations are completely enclosed and can contain liquid as well as solid

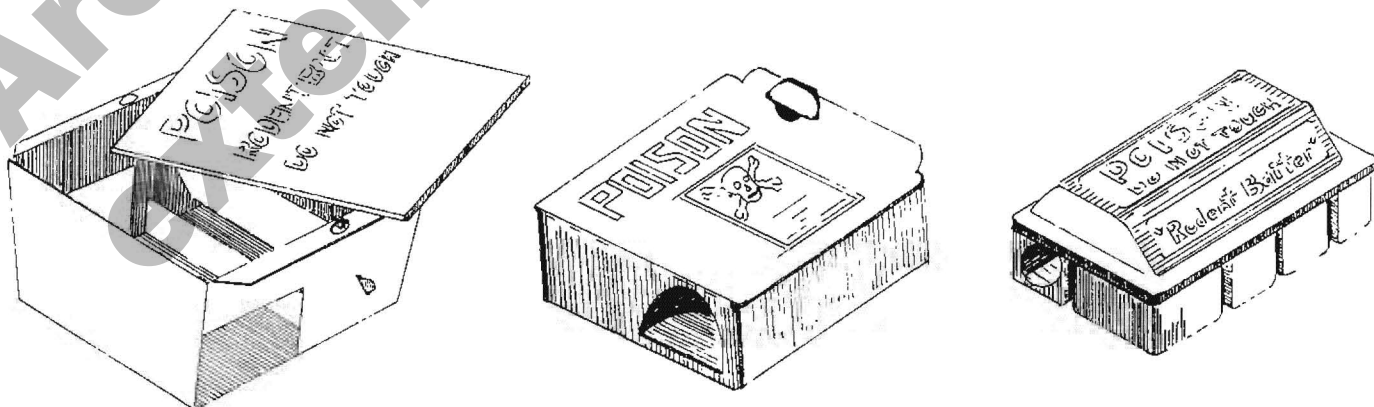

Figure 1. Examples of commercially manufactured rodent bait stations.

(cereal-type) rodent baits (Figure 4). A hinged lid with a childproof latch can be used for convenience in inspecting permanent stations.

Bait stations designed for rats should have at least two openings approximately 2-1/2 inches in diameter. Making these two holes on opposite sides of the station is preferable, as the rodent can then see an alternate escape route as it enters the station.

Bait stations designed for mice should have entrances 1 to 1-1/2 inches in diameter. Stations for mice can be considerably smaller than those for rats. A cigar box (10 × 6 × 2 inches high) with a hole in each end is an ideal size for a mouse bait box.

Types of bait to use

Bait boxes are ideal when using commonly available rodent baits. Most of these products are multiple-dose (anticoagulant) rodenticides. For these baits to be effective, rodents must feed on them for several days. Label instructions on such baits typically state, "Provide an uninterrupted supply of bait for at least 15 days or until signs of feeding have stopped."

Multiple-dose baits are available in several forms — loose grain, pelleted grain mixtures, paraffin-grain blocks and water-soluble concentrates. Loose grain and pelleted baits are often sold packaged in small paper, cellophane or plastic packets. The packets can be placed into the bait box intact, or can be opened and their contents placed into the box. These packets are also useful for placing bait into wall spaces, rodent burrows and other restricted locations. Rats and mice will usually gnaw into the packet to consume baits.

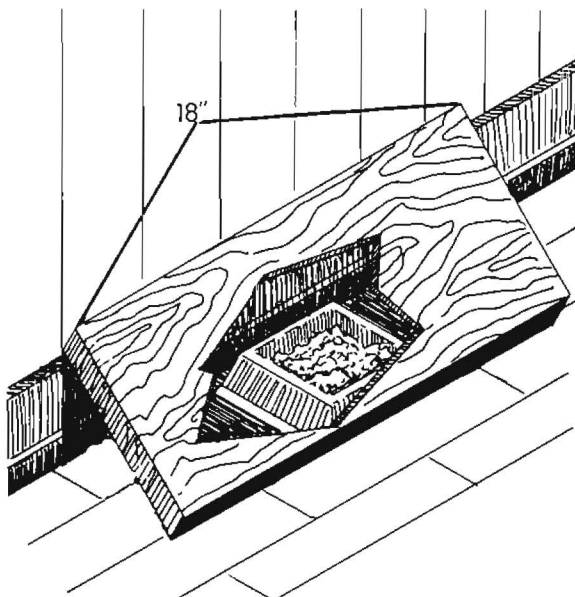

Figure 2. A flat board nailed to a wall protects rodent bait from non-target animals and allows rodents to feed in a sheltered location. The board should be at least 18 inches long to keep pets and children from reaching the bait.

Concentrates that are mixed with water to make a liquid bait are a good choice during dry seasons. They also work well in places where rodents have few water sources, such as in a granary. Liquid baits that contain a small amount of sugar are particularly attractive to rodents. Rats will often come to water stations, since they need water daily unless they are feeding on very moist food. Although mice can survive without drinking water, they will use it when it is conveniently available.

Because many kinds of animals drink water, you should protect receptacles containing liquid rodenticides from use by animals other than mice and rats. Enclosing liquid bait containers within bait stations is one method of reducing hazards to pets, livestock and desirable wildlife.

For additional information on bait types and how to select them, refer to MU publication G9442, *Controlling House Mice*.

Bait station maintenance

When using multiple-dose (anticoagulant) baits, it is very important that they be fresh and of high quality. Rats and mice will reject spoiled or stale foods. Provide enough fresh baits for rodents to eat all they want. When you first put bait boxes out, check them daily and add fresh bait as needed. After a short time, rodent numbers and feeding will decline. You will need to check the boxes only once every two weeks or once a month. If the bait becomes moldy, musty, soiled or insect-infested, empty the box, clean it and refill with fresh bait.

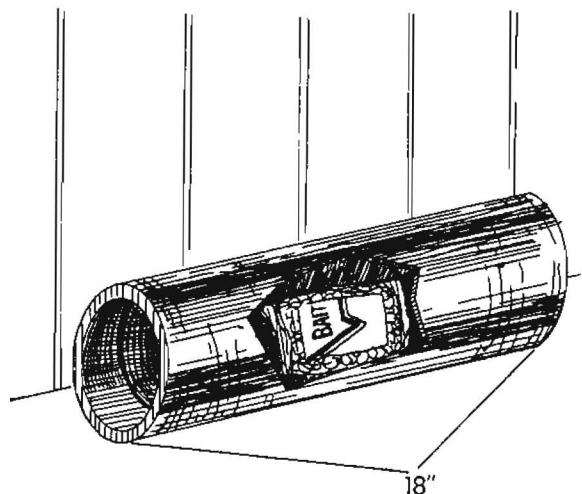

Figure 3. A rodent bait station made from a length of pipe. Pipe diameter can be 2 to 3 inches for mice; 3-1/2 to 6 inches for rats.

Dispose of spoiled or uneaten bait in accordance with the label. Follow all label directions for the product you are using.

Placement of bait stations

Proper placement of bait stations is just as important as using the appropriate rodenticide. Rats and mice will not visit bait stations, regardless of their contents, if they are not conveniently located in areas where rodents are active.

Where possible, place bait between the rodents' source of shelter and their food supply. Put bait boxes near rodent burrows, against walls or along travel routes used by the pests. Rodents usually will not go out of their way to find baits. House mice seldom venture more than a few feet from their nests or food sources, so place bait stations no more than 10 or 12 feet apart in areas where mice are active. Rats are often suspicious of new or unfamiliar objects. It may take several days for rats to enter and feed in bait stations.

On farmsteads, bait station placement depends on building design and use. For example, in swine confinement buildings or poultry houses, it may be

possible to attach bait boxes to wall ledges, to the top of pen dividing walls, and in attics or along floor or alleys where rodents are active (Figure 5).

Never place bait stations where livestock, pets or other animals can knock them over. Spilled bait may be a potential hazard, particularly to smaller animals. All types of rodent baits are poisonous to other animals to some degree. Pigs and dogs are especially susceptible to anticoagulants.

Where buildings are not rodent-proof, permanent bait stations can be placed inside buildings, along the outside of building foundations or around the perimeter of the area. Rodent control programs often are not effective indoors unless rodents are also controlled outdoors. When maintained regularly with fresh anticoagulant baits, these bait stations will help keep rodent numbers at a low level. Rodents moving in from nearby areas will be controlled before they can reproduce and cause serious damage.

This publication is adapted from *Bait Stations for Controlling Rats and Mice*, NebGuide G82-624, developed by Robert M. Timm, former Extension Vertebrate Pest Specialist, University of Nebraska, 1982.

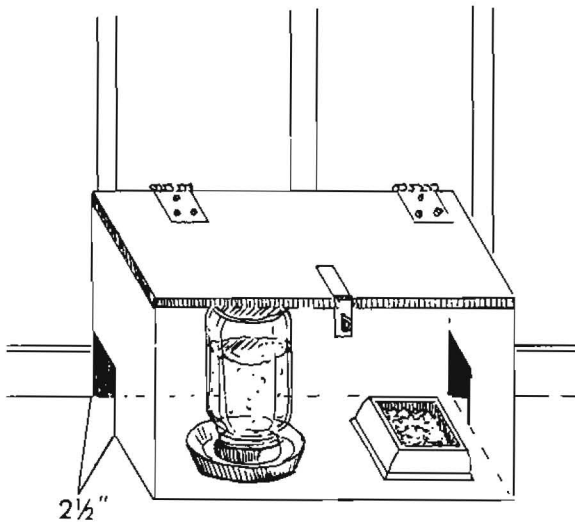

Figure 4. A homemade rodent bait station can contain liquid as well as solid (cereal) baits.

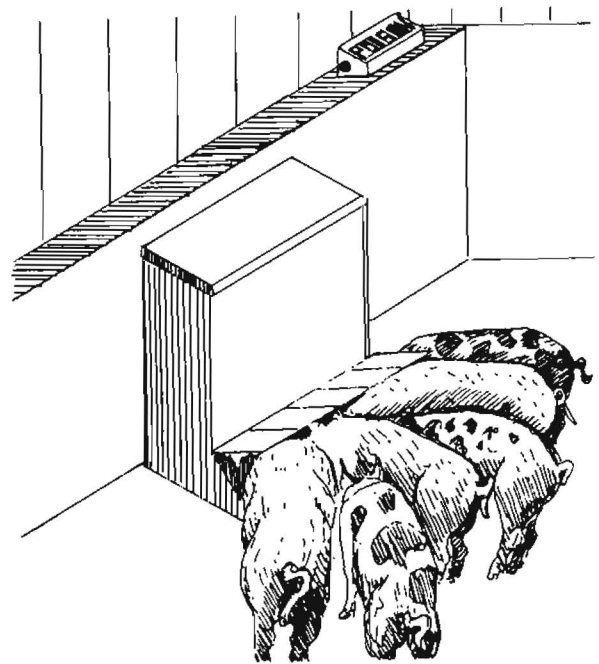

Figure 5. A rodent bait box attached to the top of pen dividing walls in a swine confinement facility. When used in such locations, bait boxes must be securely fastened and out of the pigs' reach.



■ Issued in furtherance of Cooperative Extension Work Acts of May 8 and June 30, 1914, in cooperation with the United States Department of Agriculture. Ronald J. Turner, Interim Vice President, University Outreach, and Interim Director, Cooperative Extension, University of Missouri and Lincoln University, Columbia, Missouri 65211. ■ An equal opportunity institution.