

AGRICULTURAL

MU Guide

PUBLISHED BY UNIVERSITY EXTENSION, UNIVERSITY OF MISSOURI-COLUMBIA

Starting a Fire in a Wood Stove

James Pastoret, School of Natural Resources

People who are dissatisfied with wood stoves say they're dissatisfied because of the hassles and problems they have when starting fires in them. Starting a fire in a wood stove is a considerable undertaking when compared to starting a fire in a gas or oil furnace. They require only turning up the thermostat.

For the best results in starting a wood fire, you should have a well-thought-out "standard operating procedure."

How to start a wood-stove fire

Diligent wood-stove operators have all the necessary firestarting materials readily available at the stove site. Materials include newspaper, 2-inch cardboard strips, kindling, small pieces of cordwood and matches.

Separate four or five full pieces of newspaper. Bunch and compress some newspapers and lay them on the bed of the fire box just in front of the door. Lay a few 2-inch strips of cardboard on top of the newspaper, and place several pieces of small kindling wood or dry bark on top of the cardboard. Finally, place one or two small pieces of cordwood split to about a 2-inch diameter on top of the pile. Open the stove vent as far as it will go and light the fire (see Figure 1).

After the cordwood pieces have ignited and burned for several minutes, add one or two larger pieces of wood. It's a good idea to turn and bunch the burning debris together before adding the larger pieces. Keep the air vents open for several minutes or until the larger pieces are well-ignited. Then adjust the vents according to the desired heat output of the stove.

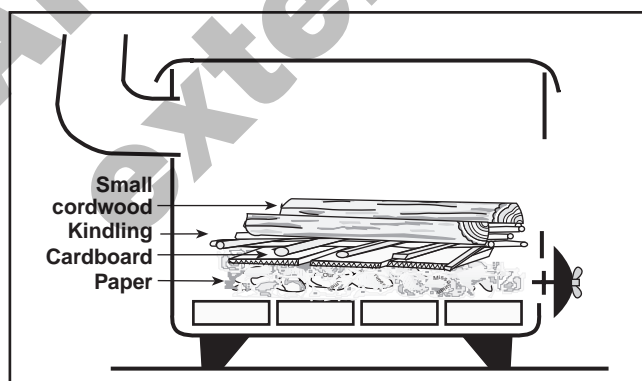

Figure 1. Layer materials to start a fire.

In terms of flammability, cardboard strips about 2 inches wide and 6 inches to 8 inches long are good material. You can start most fires without cardboard, but if you have cardboard boxes around the house, this is a useful way to get rid of them. The cardboard cuts up easily if you use a bread knife with a serrated edge. Studies show cardboard probably produces a faster and more positive start up.

Other factors

Exceptions to the standard procedure exist. Most of the factors discussed in the following section apply to conventional airtight wood stoves but not necessarily to stoves that incorporate a catalytic combustor.

Experienced and knowledgeable wood-stove operators know they can be confronted with variable factors when starting a fire. Some variables include:

1. Moisture content of materials used to start a fire. These materials should be as dry as possible. Green kindling will not give you the results you want.
2. Speed and direction of the wind outside in relation to the chimney. Generally a fairly windy day will create a good "draw" on a properly designed chimney. Sometimes winds are blocked by obstacles such as trees or other buildings. Results are not as good when the wind is blowing from "blocked" directions. On calm days, you may have trouble getting the chimney to draw. (Draw is defined as the movement or flow of air from the inside of the house, through the vent and fire box and up the chimney. Draw is created by physical factors such as differences in pressure or temperature between the fire box and the top of the chimney.)

3. The temperature difference between the inside of the house and the outside can affect the draw. The greater the difference in temperature, the greater the drawing effect. On a cold day, you can have a temperature effect, even if the wind speed outside is low. On a mild day (outside temperature greater than 32 degrees), the temperature differential will be lower, and the temperature draw effect will be reduced.

You can check the draw of a stove any time by simply opening the stove door and striking a match. If a good draw exists, the flame will bend toward the fire box and may even be blown out by the strength of the

air movement. On the other hand, the match may indicate a negative draw, and the flame will bend away from the fire box. If little or no draw exists, the match will burn easily, and the flame will remain upright.

Difficult situations

We have identified three basic elements that control draw in a wood stove. They, in turn, control the stove's ability to heat. The elements are:

1. Dryness and flammability of starting materials.
2. Outside wind.
3. Temperature difference, outside to inside.

If all elements are favorable, you should have no trouble with the draw, assuming the chimney is properly designed and built. If all the elements are unfavorable, it probably would be wise to turn to your alternative heat source on that day. However, if you have no alternate source, you may be forced to try to start a fire under unfavorable conditions.

On a cold, calm day you may find it difficult to light a fire because there's no wind passing over the top of the chimney. If you tried the match "flame" test, you may find a negative pressure present. The question is, "How do I start a fire under these conditions?"

We assume you have plenty of dry materials. You must emphasize the large temperature differential between inside and outside temperatures. Remember, hot air rises in a proportionate manner — the greater the temperature differences, the **faster** the rate of rising.

In this case, rather than trying to start the fire in a conventional way, wad five or six sheets of newspaper and place the wad below the stove pipe leading into the fire box. Ignite it (see Figure 2). The paper burns rapidly, warming the chimney. This creates a positive draw. Quickly add more paper and fine kindling. This heats the chimney more and eventually establishes a favorable situation for a continued fire.

The temperature differential between the inlet air at the vent (assume 70-degree room temperature) and the temperature at the top of the chimney (assume zero-degree design temperature) is 70 degrees before the fire is started and is 800 degrees to 1,000 degrees after the fire is started. Once the fire is going and you have accumulated some hot coals, you'll find the fire will require more frequent attention on a day of this type.

Other suggestions and strategies

1. Wood stoves aren't good sources of quick heat. Compared to an oil or a gas stove or furnace, a wood stove requires a longer start-up time. Even after a fire is established in a wood stove, it requires an additional

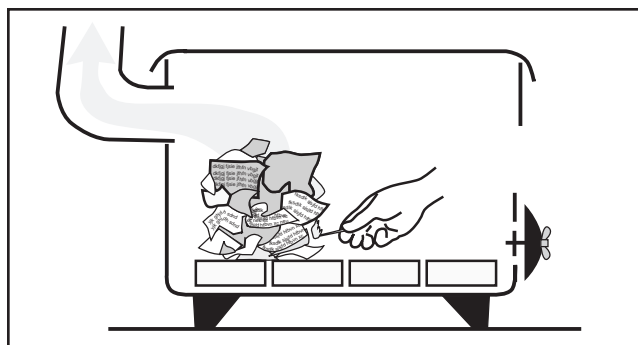

Figure 2. Ignite a wad of paper to start a fire when firestarting conditions are unfavorable.

period to heat the stove and accumulate a hot bed of coals. This can be coupled with the fact that wood stoves are usually a "point" source of heat. They often aren't connected to a duct distribution system, which is usually the case with gas and oil furnace systems.

2. Wood stoves are not an efficient source of heat for "taking the chill off" cool fall or spring mornings.

3. Because wood stoves don't operate efficiently when the draft (oxygen) is cut back (not including stoves with catalytic combustors), large stoves are frequently self-defeating. For a wood fire to burn efficiently and cleanly, it must burn hot most of the time. Many who buy wood stoves think that a larger stove is better. This is not always the case. Stoves burning with the draft turned down are burning at a greatly reduced efficiency — about half the active (hot) burning rate, and most creosote is produced during the low or cold burn stages.

4. Wood stoves aren't designed to "hold" a fire. Many people want to "bank" their stoves at night. They slow the fire to smoldering so they can **conveniently** open the draft in the morning to begin heating the house. A banked stove gives little heat and is not an effective heat source.

5. Instead of banking a stove at night, allow the fire to die out after everyone in the house goes to bed. In the morning, build a new fire. If you need heat for a short time, use an auxiliary "quick-response" source, such as an oil or natural-gas stove or furnace.

6. A wood stove is most effective (efficient and safe) when it is used in cold weather (below 32 degrees and falling) and for longer than one hour. Remember, a wood stove is really a **cold-weather heat source**. There is nothing scientific about the above temperature and time period. Those are simply suggested levels.

7. Don't use petroleum fuels to start a fire in a wood stove. This includes charcoal starters.