

Grain Storage Management

A guide for keeping
your grain in top
condition

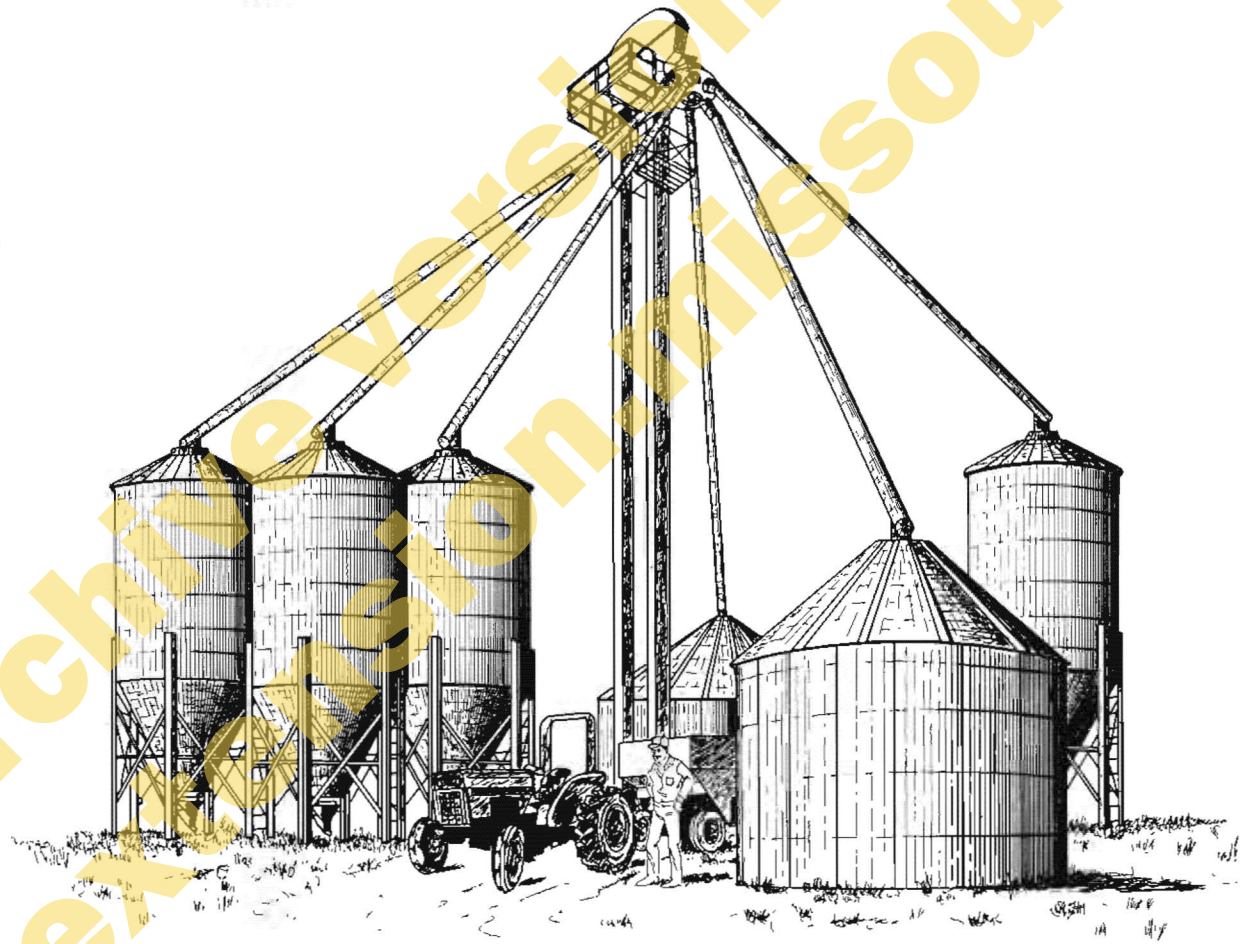

Grain storage management

by

David Williams - Dept. of Agricultural Engineering

Einar W. Palm - Dept. of Plant Pathology

Gene Munson - Dept. of Entomology

David Baker - Dept. of Agricultural Engineering

Table of contents

Introduction	2
Common storage problems	3
Storage molds and their control	4
Storage insects and their control	9
Aerating and checking grain during storage	13
Managing grain in flat storage systems	18
Observation and actions in management of dry stored grain	19

Storage molds and their control

Storage fungi can cause serious losses in stored grain. They are the **cause**, not the result, of spoilage. Bin burning, mustiness and heating are often associated with storage molds. In wheat, germ damage or "sick" wheat can occur. Storage fungi invade the germs primarily and preferentially, so both commercial grain and grain held for seed are vulnerable to storage molds.

The importance of molds in stored grain is often not fully realized. They are usually not noticed, largely because the fungi often grow inside stored grain without obvious outward signs. The microscopic fruiting structures show up only after careful laboratory analyses.

When storage molds are active they produce large masses of spores. The problem then becomes noticeable and a subject for concern. By that time, considerable damage may already have occurred. If the grain is stored for use as seed, mold invasion can often affect the embryos, destroying seed germination.

If the grain is stored for milling and baking purposes, mold growth is of even more concern. There is a causal relationship between mold development and loss in quality. For example, sick wheat, which is primarily caused by certain storage molds, is a condition in which germs have been killed and are discolored and shrunken. Flour made from wheat that includes sick wheat kernels has inferior baking qualities and reduced value.

If grain is used for livestock feed, you have many factors to consider. Feeding moldy grain to livestock can cause poor performance. At its worst, it may produce toxic effects that can cause health problems or death.

Causes of storage molds

Fungi that cause storage problems can come from field infections or can invade stored grains. For instance, several *Fusarium*-type molds, such as *Gibberella* ear rot and *Fusarium* ear rot, begin as field infections that can go on to damage stored corn. *Aspergillus flavus* may invade corn in the field and can also grow in storage if the conditions are right.

Helminthosporium spp., *Cladosporium* spp., *Penicillium* spp., *Alternaria* spp. *Rhizopus* spp. and other fungi are also common to storage problems. Perhaps the most common storage fungi involve *Aspergillus* and *Pencillium* species. Whole books have been written describing the various species and their activities.

Various fungal species have different optimum temperature and moisture requirements. Some fungi may begin an infection; others follow in a chain reaction as moisture and temperatures are increased by fungal activities. As a result, grain deteriorates more and more with time unless you correct the condition.

Conditions that encourage storage molds

Major factors that involve invasion and damage by storage molds are: Contaminated augers and debris around facilities; moisture content; temperature; length of time of storage and condition of grain in the bin.

Contaminated augers and debris. Old grain residues left in augers or in or around the grain storage facility are sources of contamination of the new grain. It is almost inevitable that debris from former operations will be contaminated with a wide range of storage fungi.

Moisture content. A moisture content below 13 percent in starchy seeds such as corn, barley, rice and sorghum, and below 12 percent in soybeans essentially prevents invasion by storage fungi. As the moisture content in the bin rises above these levels storage fungi invasion can occur with increases in temperature and time.

Moisture may also shift from place to place in a bin of stored grain. The transfer of moisture usually is greatest in cool weather. In winter, the upper layers of corn in bins may accumulate a moisture content of 20 percent to 25 percent. When the temperature rises in the spring, some of this moist corn may germinate, and storage fungi may invade other grain rapidly enough to cause heating. This situ-

ation has given rise to an old superstition that grain, especially corn, has an urge to heat and germinate in the spring. The fact is that corn and other grains germinate when they are moist enough and warm enough. They heat when they are invaded by storage fungi or insects.

Temperature. Most storage fungi grow very slowly between 40 and 50 degrees F. At 80 to 90 degrees F, growth can be rapid. Under Missouri conditions when autumns remain relatively warm for several weeks, stored grain can be vulnerable to fungus invasion.

Length of time of storage. Although in some years it may be possible to safely store grain for a short time before marketing or processing at higher moisture levels than shown in Table 1, this is still a high risk practice. If temperatures remain high, mold development can become serious and losses can be significant.

Obviously, long-term storage has to be handled with additional attention to moisture content.

Condition of grain in the bin. If storage fungi get a start in a bin it becomes more difficult to maintain grain condition in that bin. Such grain becomes a much greater storage risk than grain that is relatively free of storage fungi in initial storage stages.

Molds and mycotoxins

Mycotoxins are chemical compounds produced by fungi (myco-fungus; toxins-poisons). They can cause illness in farm animals that eat contaminated grain. The illnesses are known as mycotoxicoses. Aflatoxin is an example of an important mycotoxin that is produced in the field and in storage. Aflatoxin is a by-product of the growth of a common storage fungus, *Aspergillus flavus*, and is extremely toxic to many animal species.

Another common toxin is vomitoxin, which is produced by the fungus *Gibberella zeae* (or *Fusarium graminearum*). This fungus is a common cause of corn ear rot and scab of wheat and barley. Vomitoxin causes vomiting and dizziness in nonrumi-

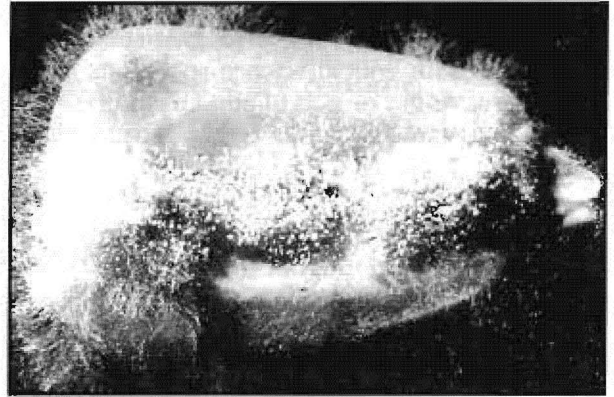

Mold spores infesting corn kernel

nant animals. Hogs refuse to eat grain that is affected with vomitoxin if the hogs have once become sick from the grain.

Many fungi that cause grain deterioration do not produce mycotoxins, even though they can invade grain in the field or in storage. Just because a given sample of grain is moldy does not necessarily mean that a toxin is involved — even by known toxin producers such as *Aspergillus*, *Fusarium* or *Penicillium* species. You should exercise caution, however, if you feed moldy grain to animals.

Signs of mycotoxin poisoning

Symptoms in farm animals that may suggest mycotoxin poisoning include vomiting, loss of appetite, weight loss, diarrhea, bleeding, nervous behavior, inability to conceive and general unthriftiness. If you observe symptoms that are suggestive of possible injury from mycotoxins, check the feed. It may be necessary to remove or modify the feeding of a certain lot of feed.

If you are concerned about feeding some grain that appears moldy, conduct on-farm trials. Pen and separate three or four test animals, and feed them for 10 to 14 days. Observe these animals closely for unusual symptoms.

If, after two weeks, the animals are unaffected, dilute the grain with high-quality grain or feed it intermittently.

It is usually best to feed moldy grain to mature animals, rather than to young or pregnant animals. Consultation with animal science specialists and veterinarians should be part of good feeding management. Assistance from toxicology laboratories may also be needed.

Early detection of storage molds

Early storage mold detection prevents costly damage to stored grain. Fungus infections and invasion are rather inconspicuous initially. By the time certain symptoms are observable, considerable deterioration has occurred.

To detect early stages of deterioration, make periodic samplings of the stored grain. Take several samples from different areas of the storage facility. Assess each sample for moisture content, discoloration and odor, visual evidence of mold growth and evidence of heating.

Moisture content

If moisture content is higher than required for safe storage pay prompt attention to reducing the moisture level. When the moisture level in a bin, or in a part of a bin, rises above 15 percent, molds develop rapidly and serious deterioration can result. If there are variations in moisture levels among the samples as indicated by moisture meter readings, this could suggest "hot spots" of mold growth (and/or insect invasion).

Discoloration and odor

If the grain shows signs of discoloration, this may be caused by fungus activity. For example, "blue eye" rot, caused by *Penicillium* species, occurs on stored corn with high moisture content. It is characterized by a bluish-green germ. Both field and storage fungi may cause discoloration of whole kernels or portions of them, including the embryo. Discoloration, a factor in commercial grain grading,

can result in lower grades and lower price.

If a musty odor is present, fungus growth is almost always involved. Serious deterioration has occurred.

Visual evidence of mold growth

Visual evidence of molds may be possible, especially in seriously affected grain. While the first stages of kernel invasion by fungi are not detectable by the unaided eye, the mycelial growth of the various storage fungi may be thick enough to be seen. When external symptoms appear, mold growth is fairly well advanced. If green or black mold growth is seen on the kernels or on fragments, corrective measures should be taken promptly.

Evidence of heating

Evidence of heating can be detected by probing the grain and checking temperatures. Heating is usually a direct result of initial fungus activity. If all or some of the grain is moist enough when stored, or if moisture transfer occurs from temperature differences within the bulk ("hot spots" initiated by fungi and insects) the grain may acquire a high enough moisture content to allow further fungus development.

Usually there will be a succession of fungi involved as the induced moisture content and temperature increase.

First, *Aspergillus glaucus* infects the grain, and it can raise the temperature up to 95 - 104 degrees F. (35 - 40 degrees C). Then, *A. candidus* and *A. flavus* follow. They can raise the temperature up to 131 degrees F. (55 degrees C) and hold it there for several weeks.

Depending upon whether the metabolic water produced by these fungi and water distilled from the "hot spots" by their heat of respiration is carried off or is accumulated in the grain, the heating may gradually subside or may pass to the next stage — thermophilic (heat loving) organisms. When thermophilic fungus species take over, they

Table 1. Safe storage moisture for aerated good quality grain

Grain	Maximum safe moisture content*
Shelled corn and grain sorghum	
Storage until spring	15 1/2%
Storage up to 1 year	14 %
Storage longer than 1 year	13 %
Soybeans	
Storage until spring	14 %
Storage up to 1 year	12 %
Storage longer than 1 year	11 %
Wheat, oats, barley	
Storage up to 6 months	14 %
Storage longer than 6 months	13 %
Sunflowers	
Storage up to 6 months	10 %
Storage longer than 6 months	8 %
Rice	
Storage until spring	13 %

*If grain quality is poor, reduce moisture content by 1 percent

may cause temperatures of 140 - 149 degrees F (60 - 65 degrees C). They are followed by thermophilic bacteria that carry temperatures above 167 degrees F (75 degrees C), the maximum temperature attained by microbial heating.

Under some conditions, chemical processes take over and carry the heating up to the point of spontaneous combustion. Each stage of heating reduces the quality of the grain, and eventually there is a caked and black mass which is worthless.

The heating starts in the fines and broken particles of grain, which accumulate in spoutlines in bins. Weeds and other debris may also contribute to

high moisture content and subsequent heating unless reversed by appropriate aeration, rebinning, or artificial drying.

Proper management can minimize the losses resulting from storage mold and insect problems.

Table 1 gives maximum safe moisture contents for different grains and lengths of storage. If the grain is of poor quality due to drought, frost, unusually high foreign material or harvest damage, reduce the levels by 1 percent.

Identifying particular molds requires special techniques. Only specialists with proper equipment can determine the number and kinds of fungi

in a sample of grain. Larger grain firms have laboratories that are equipped to do this work. Private and public laboratories are also able to determine the species of fungi that may be involved. The State Extension Diagnostic Laboratory in the Department of Plant Pathology, 3-22 Agriculture Bldg. and the toxicology section of the Veterinary Medical Diagnostic Lab, College of Veterinary Medicine (both at the University of Missouri-Columbia) are equipped to handle mold and toxin identification.

Control of storage molds

Storage molds and the grain damage they can cause can be successfully controlled by using prompt and specific engineering principles.

- Reduce grain moisture level below 15% as soon as possible;
- Use aeration to reduce (or increase) temperature conditions in the bin according to seasonal needs;
- Use artificial drying when needed;
- Exercise strict sanitation of bins, augers, and other facilities;
- Monitor facilities for changes in moisture and temperature throughout the storage season and apply corrective measures if "hot spots" or other problems arise;
- Apply fungicides to supplement other management.

Moisture level adjustment

Moisture content below 13% in starchy seeds such as corn, barley, rice and sorghum and below 12% in soybeans will prevent invasion by storage fungi. As moisture content in the bin rises above

these levels, invasion by storage fungi can occur with increases in temperature and time.

Therefore, maintaining moisture levels below 15% — by drying and in-bin aeration — will fairly well inhibit most storage mold development.

Mixing grain at lots of different moisture levels to obtain a presumed safe average for storage or to meet a given grade can lead to trouble. The moisture content in such mixes may never equalize, and the mixes could turn into high storage risks. Moisture content of the individual kernels in a supposedly uniform lot of grain may differ by 1 percent or more.

Monitoring grain condition

With the seasonal changes in outside temperature and the changes that occur within the grain mass in any given facility, it's essential to monitor for fungus growth on a regular basis. (See "Aerating and checking grain during storage" section.)

Fungicide applications

Fungicide application, such as with thiabendazole (Mertect 340F) has been used in Missouri and Illinois under Section 18 label. These fungicides will inhibit *Aspergillus* and *Penicillium* species growth. The fungicide can be used with natural air or high temperature drying. Harvest grain must be at 25% or less moisture content. The fungicide helps to keep fungal development down until the grain moisture is 15% or less. It is not a substitute for other management practices, but it can provide an economically feasible option in storage management.

Fungicides for storage mold control have some very important opportunities for the future, once approval is granted by the EPA.

Storage insects and their control

This section outlines the identification, biology and behavior of the major species of stored grain insects in Missouri.

Primary pests of sound grain: Beetles

Granary Weevil, *Sitophilus granarius*. Adult granary weevils are about 0.2 inches long. The head is prolonged into a distinct snout, and elbowed antennae come off the snout near the head.

The granary weevil is polished red to dark brown. The thorax is well marked with oval pits. This species cannot fly and has no wings under the hardened wing covers.

The larvae are soft, white, legless grubs with dark heads. They develop within the grain kernel, after the female weevil, which has strong mandibles at the end of her snout, chews a small hole in the kernel and deposits a single egg in the hole. She seals the hole with a gelatinous material.

Granary weevils are found in infested grain and grain residues. Development occurs only at temperatures above 55 degrees F, and a complete life cycle takes five weeks.

Rice Weevil, *Sitophilus oryzae*. The rice weevil has a snout and is about the same size as the granary weevil. Its thorax is marked with round pits; its color is a dull red-brown with two light-red to yellow spots on the outer wing covers. This species can fly, so fully-developed wings are found under the wing covers.

The female deposits eggs and covers in the same manner as the granary weevil. The cycle from egg to adult is completed in about four weeks.

This species might infest grain in the field before harvest. The weevils are destructive pests and can destroy grain in elevators and bins if conditions are favorable and if grain is left undisturbed.

Lesser Grain Borer, *Rhyzopertha dominica*. The adults are 0.1 inch long, dark brown beetles. They have cylindrical bodies with many small pits on the wing covers. The head is directed downward, so it is not visible when the insect is viewed from above.

The female deposits her eggs in clusters of 2 to 30 eggs outside the grain kernels. Most of the newly

hatched larvae chew their way into the kernel and develop there. Some of the larvae may feed on fines and develop as free living insects in the grain.

The larvae are a creamy white grub with three pairs of small legs. The abdomen is slender near the thorax and grubs have a C-shaped appearance.

Both larvae and adults are primary grain pests and may reduce sound grain to dust with their combined feeding. The adults are winged and may fly to spread infestations.

Primary pests of sound grain: Moths

Angoumois Grain Moth, *Sitotroga cerealella*. The larvae of this species attack and feed within a variety of grain, although they are primarily pests of ear corn stored in cribs. The occurrence and importance of this pest is not as great now as in the past because of the increased use of picker shellers.

Bin infestations are usually confined to the grain surface.

Angoumois grain moths are 0.3 inches long with a wingspan of about 0.5 inches. The front wings are clay yellow and the hind wings are gray. Long fringe on the rear margin of front and hind wings are identifying characteristics for this insect.

The female lays eggs singly or in small groups on or near the grain. The newly hatched larva spins a small cocoon on the kernel and bores a small entrance hole. Larvae develop inside the kernel, and when fully grown are 0.2 inch-long caterpillars with yellow heads. They pupate inside the kernel, then adult moths emerge. This insect may also infest grain in the field before harvest.

Secondary pests of damaged or out-of-condition grain: Beetles

Sawtoothed Grain Beetle, *Oryzaephilus surinamensis*. Adult sawtoothed grain beetles are dark brown, flat insects about 0.1 inch long. Their most distinguishing characteristics are the six sawlike

distinguishing characteristics are the six sawlike teeth on either edge of their pronotum. Their narrow, flattened body is well adapted for crawling into cracks in the food material. The adults have wings but have never been observed flying.

Female sawtooth grain beetles lay eggs singly or in small clusters in cracks or crevices in their food material.

The development of this species depends on temperatures. The life cycle from egg to adult could take from 27 to 375 days, and the adults may live for up to three years.

The sawtooth grain beetle is a pantry pest but is frequently found in grain bins and grain handling facilities.

Flat Grain Beetle, *Cryptolestes pusillus*. The flat grain beetle is the smallest of the stored grain beetles; it is less than 0.1 inch long with antennae nearly as long as its entire body. The red-brown adults are very active.

The larvae are slender and pale with a black head and a pair of slender spines on the tip of the abdomen.

The flat grain beetle is among the first insects to attack newly binned grain if the moisture is high.

Red Flour Beetle, *Tribolium castaneum*. Flour beetles are secondary pests that lay their eggs in dusts, fines and dockage accumulations in the bin. The eggs are covered with a sticky fluid, which adheres debris to them making a perfect camouflage. Beetles are red-brown and about 0.1 inch long.

The larvae are 0.3 inches long, and are yellow-white in color. They have a dark head and dark projections on the tip of the abdomen.

Secondary pests of damaged or out-of-condition grain: Moths

Indianmeal Moth, *Plodia interpunctella*. Infestations of this species are most common in the upper 4-to-6 inches of grain in a bin.

Indianmeal moths at rest are about 0.4 inches long. The wingspan is about 0.1 inch. The outer portion of the front wing is copper and the inner

part is gray. The hind wings are gray and have no markings.

The larvae are yellow-white to pink with a light brown head.

The moths deposit their eggs in the upper surface of the grain mass and larvae move about feeding on damaged grain and produce a silken web as they feed. The full-grown caterpillars, which are 0.7 inches long, may leave the grain and pupate on the walls of the bin. A generation may be completed in six to eight weeks.

Storage insect control: Before harvest

Grain stored on the farm may become infested with insects in two major ways. In the southern portions of the state, insects such as the rice weevil, lesser grain borer and the Angoumois grain moth may infest grain in the field and be brought into the storage facility.

The second, and most likely form of infestation, is when insect populations develop in and around improperly cleaned bins and grain handling equipment.

Sanitation. This second cause of infestations makes prebinning sanitation essential in a grain management program. Thoroughly clean all grain residues from the bins and remove all residues from combines, feed bunks or nearby feed storage areas, trucks and augers. These residues will be the main sources of insect infestations for farm-stored grain.

Residual insecticides. After all debris and grain residues are removed, apply an approved residual insecticide to the inside of the bin. Spray the insecticide around the exterior and to all areas where residues were removed. Spray all surfaces until wet. Usually one gallon of finished spray will cover 1,000 square feet.

Fumigation of empty metal grain bins. The increased use of metal bins with perforated floors for grain drying and aeration has helped produce a serious insect problem in farm-stored grain. Grain residues sift through the floor openings, creating a favorable environment for insect development. The floors are difficult to remove, which makes inspec-

tion, cleaning and spraying impractical.

If you won't remove the residues or penetrate them with the residual spray, disinfect the area with an approved fumigant. Use tape and polyethylene sheeting to seal all openings in the bottom half of the bin. Select a day that is calm with temperatures above 60 degrees F. Apply the fumigant through the ventilation door on the bin roof. Wait 24 hours before airing out the bin. Fumigation leaves no residue to protect against later invasion of pests, so you must use a residual surface spray after airing.

Control rodents. Make bins as rodent- and bird-proof as possible. Use rodenticides regularly around the bins, but not inside them. Do not add new grain to old grain unless insects are eliminated.

What to do after harvest

The grain must be dry for long-term storage. The grain should be cooled in the fall and warmed in the spring to minimize moisture migration.

Grain protectants: Insecticide sprays or dusts protect grain being stored for long periods and newly-harvested grain, which is most susceptible to insects. These insecticides work best when applied to the grain as it is augered into the bin.

If you are storing the grain for more than one year, it is a good management practice to move grain from one bin to another. You then know the exact condition of the grain and can reapply grain protectant insecticides.

Level grain surface: After applying the insecticide protectant and after binning is complete, level the grain surface. Leave 6 inches of space between the grain surface and the top of the bin wall to eliminate gas spill-over if fumigation is required.

Surface treatment: When bin fill is complete, grain is in storage condition and the grain surface is level, you should apply an approved insecticide or insecticides to the grain surface. This forms a barrier against insect infestation. You may apply a surface treatment when you're going to store grain during a warm season or after fumigation to prevent reinfestation. Surface treatments are effective if the grain mass is not infested and if this surface barrier

is not disturbed. Normal grain aeration does not affect the protection of surface treatments.

Monitoring and safety systems for stored grain fumigation

During fumigation application (the time between opening the first container, applying the appropriate dosage and closing the fumigated site) no applicator or employe may be exposed to more than 0.3 parts per million (ppm) per 8-hour time weighted average (TWA). All persons in the treated area and in adjacent indoor areas are covered by this exposure standard. If exposure limits cannot be met through engineering control (such as forced air ventilation) or work practices, all people in the area must wear appropriate respiratory protection gear.

After application, no person's exposure may exceed 0.3 ppm ceiling (maximum concentrations) at anytime. Such exposure could occur if the fumigated area leaks, if the treated commodity is transferred or handled or if someone enters a non-aerated or partially-aerated space. The area must be monitored to assure that this exposure limit is not exceeded. Again, if limits can't be met through engineering or work practices, all people in the area must wear the appropriate respiratory protection, as shown on the following page.

Air sampling

For any application performed inside a building or from within the space to be fumigated, you must take enough readings with a low-level detection device to determine if the applicator exposure limit (0.3 ppm 8-hour TWA) is exceeded.

Three types of instruments take gas readings and can be used to monitor exposures. They are: personal breathing zone pumps, electronic direct readout devices and colormetric tube detectors.

The colormetric tube detectors (such as the Draeger Multi-Gas Detector, AUER-MSA Detector) are probably the most practical measuring devices to use for on-farm application. Low-level detector

urements in the worker's breathing zone.

The EPA recommends that applicators or employers document exposure readings in an operation's log or manual for each fumigation site. These records can be documented for worker exposure and verify compliance with the standard.

You should also monitor the site upon the completion of aeration and during the transfer or handling of incompletely aerated commodities.

Personal protective equipment

Before applying any fumigant, every applicator should review the label and determine what personal protective equipment must be worn when applying or entering a fumigated area.

Typical personal protective equipment required for fumigation are dry cotton gloves and proper respiratory protection. The standards require respiratory protection equipment approved by the National Institute for Occupation Safety and Health/Mine Safety and Health Administration if worker exposure limits cannot be met through engineering or work practices. The type of approved respiratory protection varies depending upon gas concentration, as shown in Table 2.

Table 2. Proper respiratory protection

<u>Gas concentration</u>	<u>Required protection</u>
0.0 - 0.3	None required
0.3 - 15 ppm	Full face canister-type gas mask*
15 ppm or above or unknown concentration	Self-contained Breathing Apparatus (SCBA)

*Note: Re-registration standard allows use of the gas mask for escape purposes at levels up to 1,500 ppm. Personal protection equipment (SCBA) must be available on location for emergencies.

Full-face canister gas masks approved by NIOSH/MSHA for protection against phosphine carry the designation TE-14G-98, and the label is now olive green instead of yellow. (The MSA part number is #460116; the code is GMC-SS-1.) When oxygen levels are not adequate enough to support life (below 19.5 percent), you must wear a Self-Contained Breathing Apparatus (SCBA).

A positive air pressure SCBA must be available at the site or locally (fire station, rescue squad) for use in emergency situations such as spills, leaks or rescues where fumigate levels are about 15 ppm or unknown. An extra filled tank should be available at the site anytime SCBA gear is required.

All users should be fit-tested and trained in proper equipment use. You should develop a procedure to ensure that equipment is maintained, serviced and spare canisters are available as needed.

Use eye protection, especially when handling and applying fumigants. Eye protection is typically included as part of the respiratory equipment.

Placarding fumigated areas

You must put placards up at all entrances of a fumigated area. Where possible, put up these placards before fumigating to keep unauthorized persons away. The placards or signs must bear the following information in English and Spanish:

1. Signal word Danger/Peligro and the skull and crossbones symbol in red.
2. The statement "Area and/or commodity under fumigation, Do not enter/No entre."
3. The statement, "This sign may only be removed after the commodity is completely aerated (contains 0.3 ppm or less). If an incompletely aerated commodity is transferred to a new site, the new site must also be placarded if it contains more than 0.3 ppm. Workers must not be exposed to more than 0.3 ppm."
4. The date and time fumigation begins and is completed.
5. Name of fumigant used.
6. Applicator's name, address and telephone number.

Aerating and checking grain during storage

Moisture migration is often to blame if dry grain spoils while in storage. Even when moisture content is low and uniform when the grain is placed in storage, changes in temperature within the grain mass cause convective air currents. The currents carry moisture from one area of the bin to another. This creates "pockets" of wet grain, which can spoil when the grain temperature is high enough.

The best way to control moisture migration is to control grain temperature. Grain is typically placed in storage between 50 and 80 degrees F. As outside temperatures gradually fall, the outer and top layers of grain cool, but the grain in the center of the mass stays much warmer. Air surrounding the cool outer grain descends until it reaches the warmer center grain, then rises (see Figure 1.)

When the warm air reaches the cool grain at the top, moisture condenses, wetting the grain. This pocket of rewetted grain usually forms a crust on the grain surface. Grain in this crust will feel wet, slimy or tacky as a result of mold growth. Kernels may stick together and if temperatures are low enough they may even freeze together.

Moisture can also migrate to a lesser extent when cool grain is carried over into summer.

Crusting is an indication of a mold growth and of an impending spoilage problem. This spoilage may occur in late fall or early winter if temperatures are high enough. Often the spoilage will not take place until spring when temperatures become high enough to allow sufficient mold growth.

If you detect crusting early you can stir the grain or mix it with drier grain to break the crust. In extreme cases, you may need to remove the crusted and spoiled grain.

In either case, start aeration immediately. Small moisture problems left unattended will probably develop into severe problems by spring.

Aeration

Aeration controls grain temperature by moving outside air through the grain. Although aeration can result in small moisture changes, it does not appreciably dry the grain. Aeration can serve other

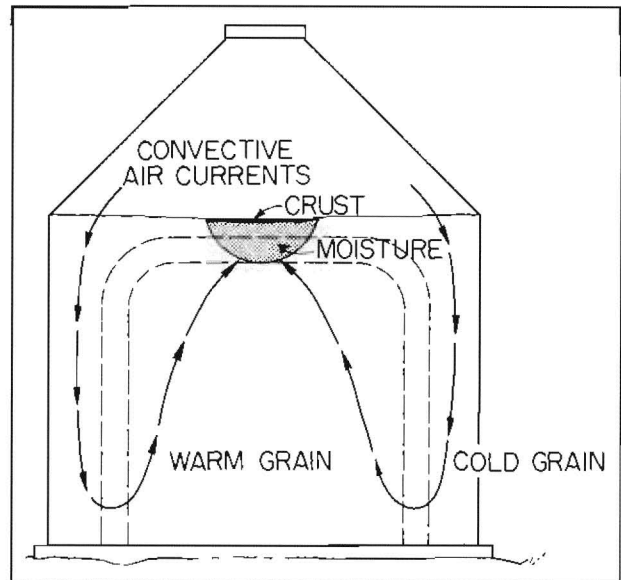

Figure 1. How grain temperatures cause moisture migration.

purposes, such as cooling hot grain from a dryer.

Proper aeration in the fall eliminates the warm mass of grain in the center of storage. Similarly, aeration in the spring eliminates the cool mass of grain in the center.

As the grain is aerated, a cooling zone (warming in spring) moves through the grain. The direction of movement of this zone depends on the aeration fan. If the fan blows air into the storage, the cooling/warming zone moves upward. If the fan sucks air from the storage, the zone starts at the top and moves down (Figures 3 and 4).

In cool weather, if the temperature of the stored grain is brought to below 50 degrees F, storage fungi grow slowly, even if moisture levels are above 15 percent. Insects and mites are also inactive.

Aeration is more effective than transfer of grain from bin to bin. Aeration also does not increase cracked or broken kernels from handling. Cracked kernels invite storage fungi.

With aeration, you need a proper understanding of outside air temperatures and humidity as compared to air temperatures and moisture in the bin. Improper aeration methods can introduce high humidity air into the stored grain.

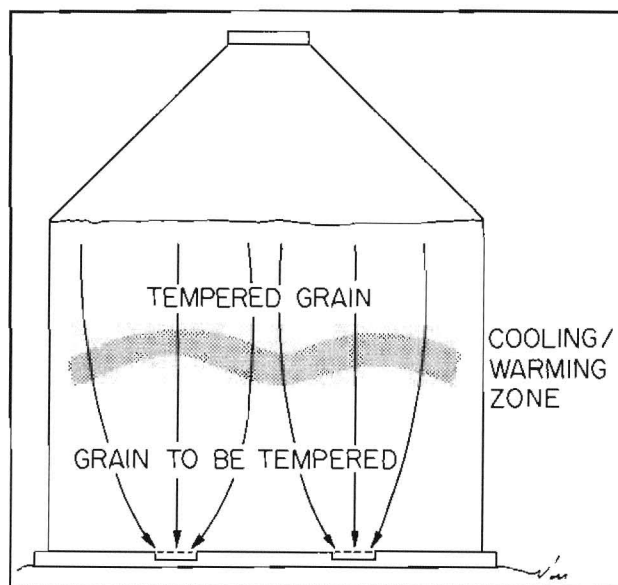

Figure 2. Negative pressure (suction) zone moves downward.

The movement of a cooling/warming zone completely through the grain is called one cycle. You should operate the fan continuously until the cycle is complete. Never shut off the fan in the middle of a cycle. This is particularly important when warming because a condensation front moves through the grain just ahead of the warming zone (see Figures 2 and 3). If you shut off the fan before this front has passed completely through the grain, moisture will be deposited on the grain.

The time required to complete a cooling/warming cycle depends largely on the airflow rate (cfm/bushel) and the time of year. You can estimate the number of hours by the following formulas:

Hours = 15/cfm/bu	(Fall cooling)
Hours = 20/cfm/bu	(Winter)
Hours = 12/cfm/bu	(Spring cooling)

These formulas provide estimates only. The accuracy of the results depends largely on how closely actual airflow rates are known.

The best way to determine the location of a cooling/warming zone is by measuring temperatures at various depths in the bin. The temperature

ahead of the zone will be 10 to 15 degrees F different from the temperature behind the zone. When all of the grain is the same temperature, the cycle is complete.

For example, a 1/10 cfm per bushel aeration fan can move a cooling cycle in the fall through the grain in about $15 + 1/10$ or 150 hours (6 1/4 days). Likewise, a drying fan capable of moving 1 cfm per bushel has a cooling cycle of 15 hours.

The desired winter storage temperature for grain in Missouri is about 40 degrees F. It usually requires two to three cooling cycles to reduce the grain temperature to this level.

Aeration costs

The cost of operating an aeration fan is small and can be estimated by the following formula:

$$\text{Operating cost, cents} = \text{hours} \times \text{fan motor hp} \times \text{¢/kwhr}$$

The cost of two or three aeration cycles usually is about 1/10 cent to 2/10 cent per bushel using

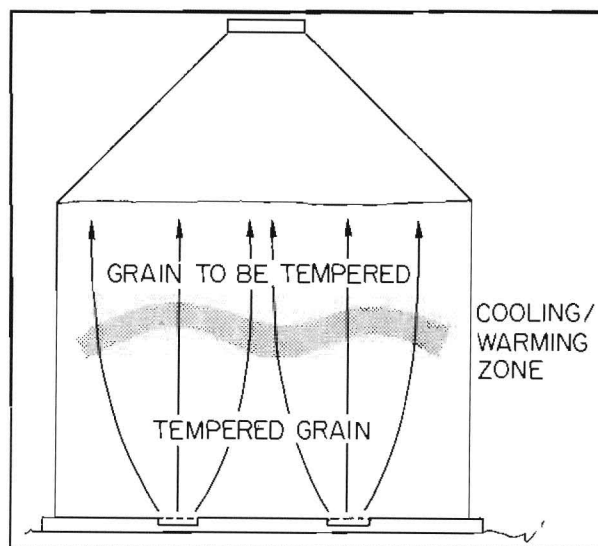

Figure 3. Positive pressure (blow) zone moves upward.

small aeration fans. Aeration expense may be slightly higher with larger capacity drying fans, but the costs are low compared to the benefits.

Aeration management procedure

In the fall, begin aeration when grain temperature is 10 to 15 degrees F above the outside temperature. Grain stored after high-temperature drying will usually be at least 10 degrees F warmer than the outside air. In this case, begin aeration immediately or at least as soon as the bin is full.

Some operators with small (1/10 cfm per bushel) airflow rate fans prefer to run them continuously until outside air temperatures have stayed at 35 to 40 degrees F for one to two weeks. Although this practice reduces the amount of management, it requires more energy than cooling in steps.

Other operators prefer larger drying fans (1 cfm per bushel capacity or more) so a cooling cycle can be completed essentially overnight. In some cases, only two or three cooling cycles are required. For example, the first cycle could begin when grain temperature is 70 degrees F and outside temperature is 55 to 60 degrees F. The second cycle can be delayed until outside temperature is 40 to 45 degrees F. At the completion of the second cycle, grain temperature will be 40 to 45 degrees F. With larger fans, it is possible to cool the grain for winter storage with 30 hours or less of actual fan operation.

With higher airflow rates (more than 1/4 cfm per bushel), cooling time is short enough so you can delay fan operation for two or three days to avoid aerating during warm or humid weather.

Regardless of the management scheme you use, or the weather conditions, check the grain frequently (at least once every two weeks). Run the fans continuously if you detect heating or hot spots.

In the spring, begin aeration when the average daily outside air temperature is 10 to 15 degrees F warmer than the grain temperature. Continue warming until grain temperature is about 60 degrees F. Once you start a warming cycle, do not shut off the fan until the warming zone has passed completely through the grain.

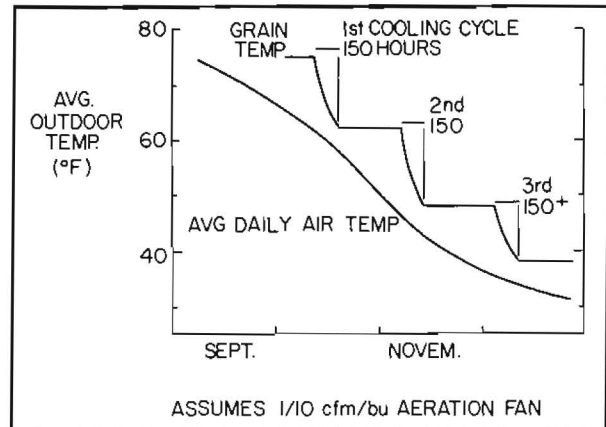

Figure 4. Cooling grain in steps

Checking grain

Check stored grain weekly during critical fall and spring months when air temperatures can change quickly. Also, check weekly during the summer. Checking twice a month may be adequate in winter.

When you check the grain, measure and record grain temperatures in the bin center and 1 1/2 to 2 feet below the grain surface. During winter, if temperatures rise more than 3 to 4 degrees F from one check to the next, turn on the fan immediately and cool the grain again as long as the air temperature is within 10 degrees F of the grain temperature.

Once the grain is cooled to the desired temperature, run the fan and smell exhaust air. Check for a musty odor, which indicates heating. If you detect an odor, run the fan until the odor is gone.

In extreme cases where you can't stop the heating, you might need to remove the problem grain for drying, feeding or selling. Even though buyers dock problem grain, selling is preferable to allowing an entire bin to go out of condition.

Temperature monitoring

In addition to tracking the progress of aeration cycles, temperature measurements also help identify hot spots in the grain.

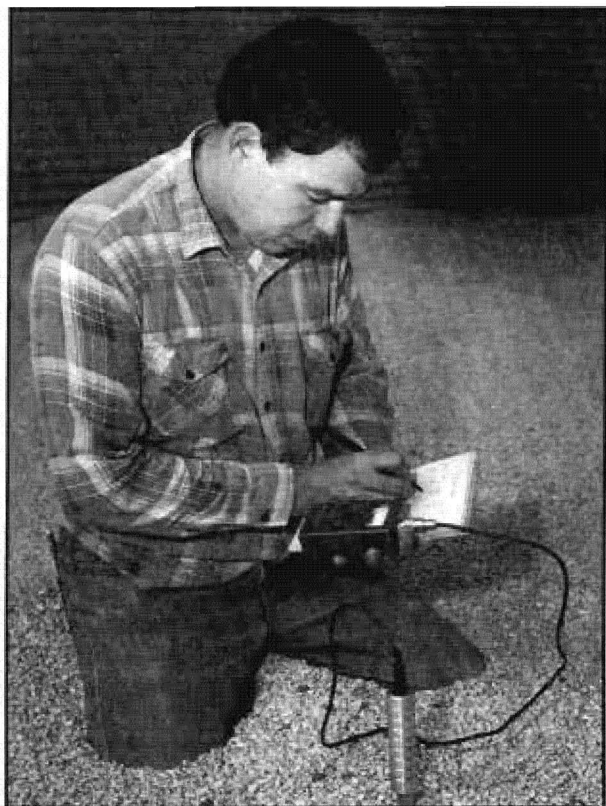

Figure 5. Monitoring and recording grain temperature with an electronic thermometer. You should probe several areas inside the bin for hot spots.

The least expensive — and yet acceptable — method of temperature measurement is a probe with attached thermometer. When using a probe, force the thermometer and probe into the grain to the desired depth and hold them there for several minutes before you remove them to read the temperature. While this is relatively inexpensive, it requires a lot of time, particularly when you have to take a lot of measurements.

Electronic monitoring equipment is now available commercially. This equipment allows quick and accurate measurement of temperatures in large volumes of grain. Commercial systems generally have three to five (depending on bin size) cables suspended from the roof (Figure 6). Each cable has four to six temperature sensors spaced 3 to

6 feet apart to allow measurement at various depths. The readouts are placed on the outside of the bin wall at a convenient location. Although initial cost of the systems is relatively high, they make an otherwise time-consuming job convenient.

The installation of an electronic temperature monitoring system does not eliminate the need to periodically enter the bin to visually check the grain for moisture changes or insect activity.

Other considerations

Fines — broken grain and foreign material — in stored grain can cause problems, particularly when they accumulate in pockets. Pockets of fines often turn into hot spots because air flow tends to go around these pockets rather than through them. The broken kernels are also more susceptible to spoilage than whole kernels.

Remove fines by cleaning grain before storing it or use a grain spreader to evenly distribute fines during filling. A spreader also helps level grain as the bin is filled. The top should be level after the last

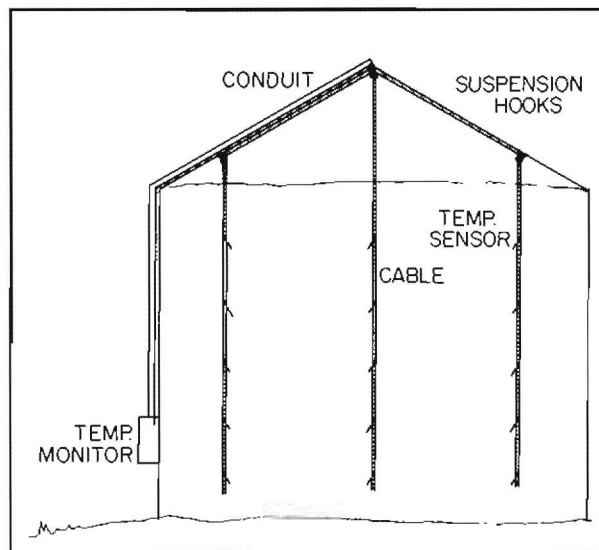

Figure 6. In-bin grain temperature monitoring system with temperature-sensitive cables.

grain enters the bin. A cone of heaped grain invites spoilage because it will not be properly aerated.

Another way to minimize problems caused by fines is to load grain into the bin without using a grain spreader. If the flow of grain is directed at the bin center, most of the fines will fall into a column in the center of the bin. As the bin is filled, periodically (at least daily) unload enough grain to remove the peak (Figure 7). Drawing down the peak this way removes many of the fines.

Commercial aeration control systems are available to control fans based on temperature and humidity. Controls can be tied to computers to monitor, control and record fan operation. These control systems are useful in relieving some management, but regular monitoring is necessary to make sure the system is working properly. Do not use automatic controls for warming grain in spring because continuous fan operation is essential.

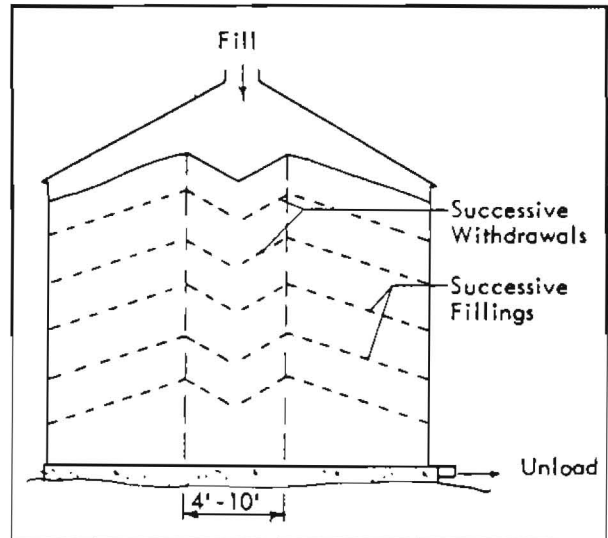

Figure 7. Withdrawing grain during filling removes many fines and helps prevent mold growth.

Managing grain in flat storage systems

The principles of grain aeration already discussed also apply to flat storage facilities, such as modified machine sheds or covered outside piles of grain. Figure 8 shows a typical layout for aeration ducts in a medium-sized flat storage such as a farm machine shed. It is imperative that the system — including duct and fan sizes, layout and walls — is properly designed for the grain being stored. A well-designed system results in proper air distribution and structural stability of the storage building. An aeration system using ducts provides better air distribution if the air is blown rather than sucked through the grain. This is particularly true in flat storage. Aeration fans for flat storage should be sized to provide a minimum of 1/8 to 1/7 cubic foot

per minute of air per bushel of grain. The management of the aeration system for flat storage is identical to that for conventional round bins. Cool the grain in the fall and warm it in the spring according to the methods already discussed for grain in bins.

Check grain in flat or other temporary storage at least as often as you would grain stored in conventional bins.

With proper management, there is no reason you can't store grain in properly designed and constructed temporary facilities. If spoilage or insect problems develop, however, they can be more difficult to control in flat storage. This underscores the importance of good management to prevent problems from developing.

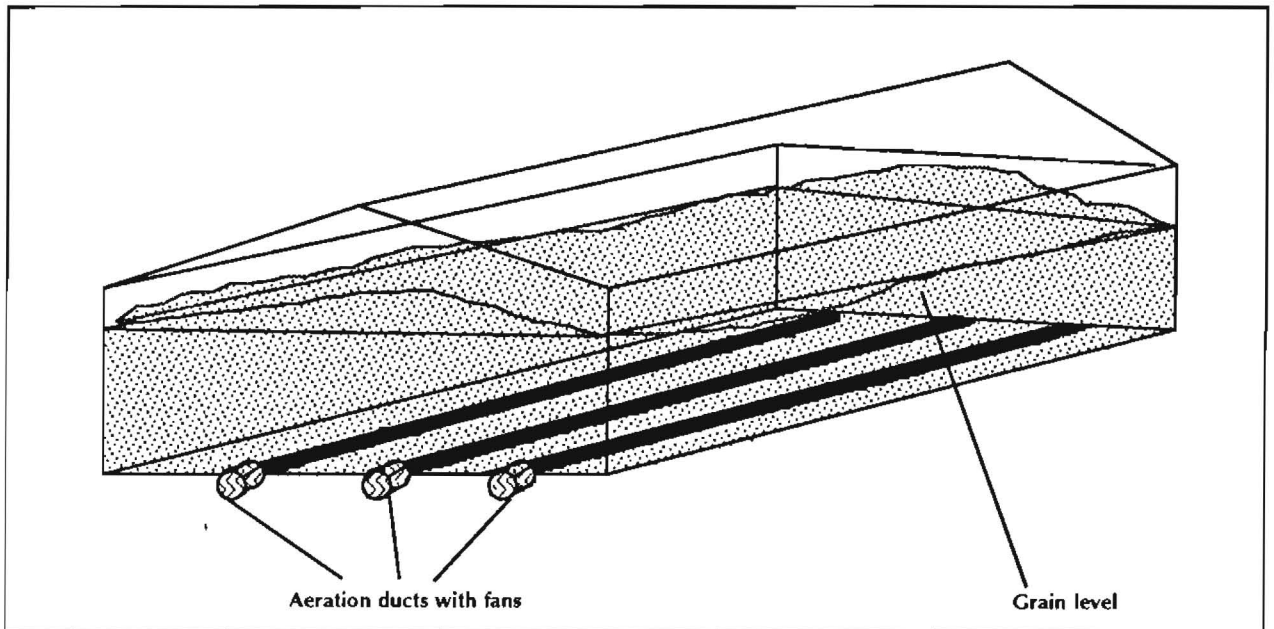

Figure 8. Typical Aeration Duct Layout for On-Farm Flat Storage.

Observation and actions in management of dry stored grain

<u>Observation</u>	<u>Probable cause</u>	<u>Solution/recommended action</u>
Musty or spoiled grain odor.	Heating, moisture accumulation in one spot.	Run the fan. Smell the exhaust while in the bin or in front of the exhaust fan. Run the fan to cool any hot spots. If damage is severe, remove the grain.
Hard layer or core below grain surface.	High moisture or spoiled, caked grain mass.	Run the aeration or drying fan. See if caked or compacted mass blocks airflow. Cool and dry if airflow is adequate. Otherwise, unload to remove spoiled grain.
Warm grain below top surface.	Moisture content too high.	Run the fan regardless of weather conditions until exhaust air temperature equals the desired grain temperature.
Surface grain wet or slimy. Perhaps grain sticking or frozen together.	Early signs of moisture migration, often noticeable only 1-2 weeks after binning.	Run aeration fan. Cool grain until exhaust temperatures equal desired grain temperature or outside air temperature.
Hard surface crust, caked and blocking airflow. Possibly strong enough to support a man.	Severe moisture migration and condensation in the top surface.	Remove the spoiled layer. Wear a dust mask to filter mold spores. Run fan to cool grain after spoilage is removed. Sample grain with probe to determine condition throughout center mass below crust. Consider marketing grain to arrest further spoilage.
Under-roof condensation dripping onto surface.	Warm grain in cold weather, severe convection circulation and moisture migration.	Aerate until exhaust air temperature equals outdoor air temperature at beginning of aeration cycle.
Wet or spoiled spots on grain surface outside center point.	Condensate drip from bolt end or under roof fixture that funnels condensate flow; possible roof leak.	Check grain for heating. Check roof under surface at night. Check for caulking around roof inlets and joints.
Wet, spoiled spot directly under fill cap.	Leaking roof cap or condensed water from gravity spout.	Check bin cap seal and hold down. Block or disconnect gravity spout so air from bin and grain cannot flow up tube. Marginal solution: Hang bucket under spout inlet and check bucket for water accumulation.
No airflow through grain with aeration fan running.	Moldy, caked grain mass blocking flow; possibly moldy grain layer immediately above aeration duct or perforated floor on suction system.	Try to determine location and scope of spoilage. Unload storage and market or re-bin good grain.
White dust visible whenever grain is stirred.	Mold on grain but not sufficient spoilage to seal top surface.	Wear dust mask in working grain. Evaluate grain condition throughout bin where possible. Observe caution in continued storage because grain condition has deteriorated to some degree.
Cooling time took much longer than usual.	Increased fines in grain resisting and reducing airflow; increased fines can cause airflow resistance to increase 2-4 times over that of clean grain.	Run fan longer time. Operate fan until grain and exhaust air temperature readings indicate grain is at desired temperature, regardless of time required.
Exhaust air temperatures in center of bin surface warmer than those away from center.	Fine material accumulation in storage center resisting airflow; airflow through center mass grossly reduced compared to relatively clean grain around outside of storage.	Run the fan sufficient time to cool the center irrespective of outside grain temperatures. Draw down the bin center to remove fines and decrease the grain depth for easier air passage in the center core.
Unknown grain conditions in the bin center.	Too deep to probe; bin too full to access; no temperature sensing cables installed.	Withdraw some grain from all bins to feed or market. Observe (look, smell, feel) first grain to flow with each withdrawal, since it was in center core. Withdraw any grain above level full as soon as possible after harvest to reduce moisture migration and permit access for observation and sampling.