

## University of Missouri Extension

G1927, Reviewed October 1993

# Spin-Through Flush Tank

**Charles D. Fulhage**  
Department of Agricultural Engineering

This guide describes the design, construction and operation of an automatic water release device for manure flushing. The tank is a horizontal cylinder and water is discharged through an opening in its side (Figure 1).

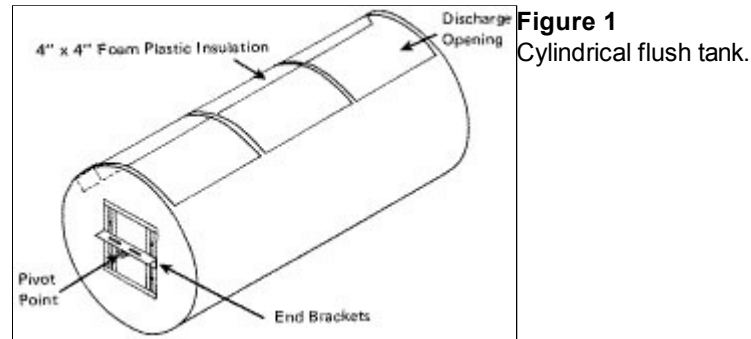

The device automatically dumps when the adjustable pivot point on either end of the tank is in the proper position. When the tank is empty, the bottom is heavy due to the opening in the top of the tank. As the tank fills with water, the center of gravity moves upward toward the pivot point. When the tank is full, the center of gravity is slightly above the pivot point — causing an unstable condition.

A piece of foam plastic insulation along the back edge of the discharge opening moves the center of gravity slightly forward of the pivot point when the tank is full. Once the center of gravity is both slightly above and slightly forward of the pivot point, the tank dumps forward. The tank is allowed to rotate in a full circle around the pivot point. No stops are used — this avoids mechanical damage due to sudden stoppage of tank rotation.

## Sizing the tank

The size of the flush tank depends on the width of the gutter being flushed and the gallon per foot gutter width required. The tank length should be as nearly the same as the width of the gutter as is practical.

Assuming the tank length and gutter width are about the same, the tank diameter required can be estimated by the following formula:

$D = 5 \times$  the square root of gallons per feet, where:

**D = tank diameter, inches**

**Gal./ft. = gallons of flush water required per foot width of gutter**

If the tank length is less or greater than the gutter width, the diameter should be adjusted to accommodate at least the volume required per flush. From a practical standpoint, most tanks probably will be selected from existing standard sizes, unless "made to order" service is available.

When selecting from standard sizes, choose a tank that will hold at least the required flush volume. Excess water over the minimum required flush volume will not diminish gutter cleaning. Tanks can be adjusted to dump automatically when partially filled.

## Sizing the discharge opening

The discharge opening should be large enough that it does not restrict the flow of water from the tank. The opening also makes the tank "lighter" on the top side so that it returns to the upright position when empty. Discharge opening widths equal to 0.6 times the diameter of the tank have worked well in model and field size installations (Figure 2).

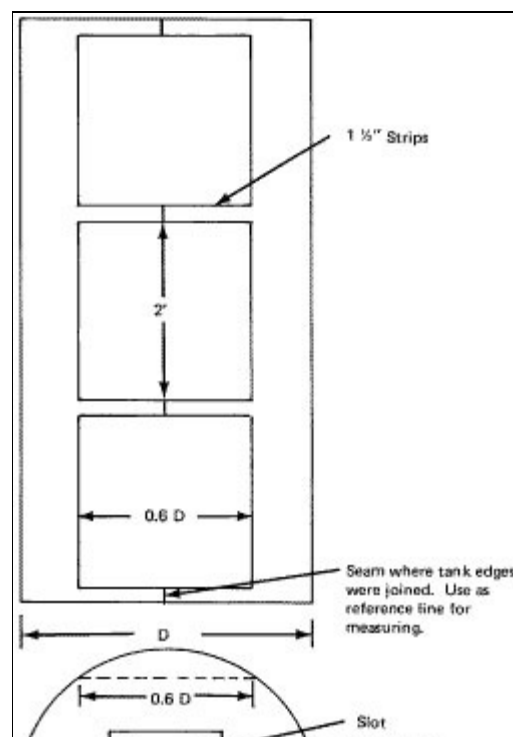

**Figure 2**  
Detail on tank discharge opening.

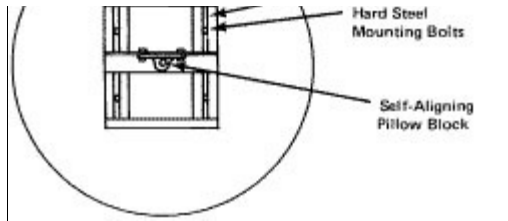

When cutting the opening in the tank, make sure it runs parallel to the longitudinal axis of the tank and does not corkscrew around the tank. One way to do this is to use the seam where the two edges of the cylinder are joined as a reference line (Figure 2).

Cut the edges of the opening an equal distance on either side of the reference line so that the total opening width equals 0.6 times the diameter of the tank. The opening should end 1-1/2 inches from the end of the tank to take advantage of the structural strength of the corner edge of the tank. Reinforcing strips 1-1/2 inches wide should be left at 2-foot intervals in the opening to keep the edges from spreading too far when the tank is full. This measurement will depend somewhat on tank length.

## End brackets

The end brackets are constructed to allow the pivot point to adjust horizontally and vertically. Adjust vertically by sliding the bracket relative to the four bolts that attach it to the tank. Adjust horizontally by sliding the self-aligning pillow block on the slotted angle iron. Details on size and construction of end brackets are given in Figure 3.

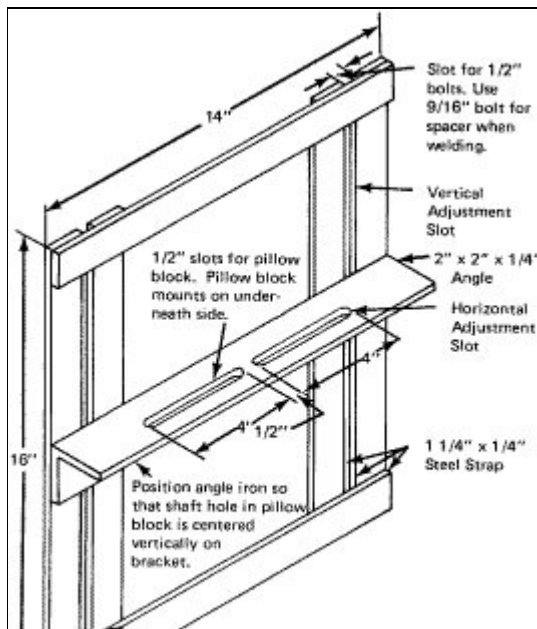

**Figure 3**  
Detail on end bracket.

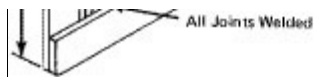

The end brackets are mounted on the tank by four bolts. Each bolt is located at the middle of its respective slot when the center of the pillow block shaft hole is at the center of the tank (Figure 4). Locate the center of the tank by measuring the circumference, starting at the reference line used as the center of the discharge opening. Mark the point on the opposite side of the reference line, which is one-half of the circumference.

Draw a diameter line across the end of the tank connecting this mark and the reference line at the top of the tank. Similarly, measure a distance around the tank on both sides of the reference line equal to one-fourth of the tank's circumference. Connect these two points with a diameter line across the end of the tank. The intersection of these two diameter lines is the geometric center of the tank. Do this for both ends.

Before drilling holes in the tank for the end bracket, make sure that the pillow block is centered on the end bracket. The pillow block is mounted on the underneath side of the angle so the weight of the tank and water does not bear on the bolts attaching the pillow block to the steel angle. Then place the end bracket on the tank so that the hole in the pillow block is centered over the center of the tank and the vertical slots on the outside edge of the bracket are parallel to the vertical diameter line (Figure 4).

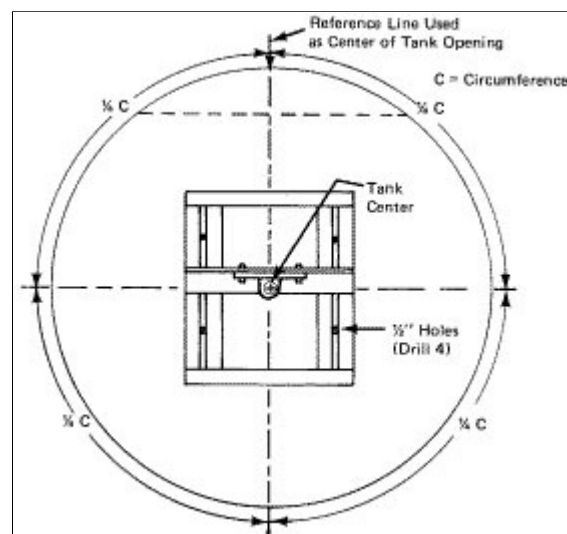

**Figure 4**  
Measuring detail for locating center.

Center punch and drill a 1/2-inch hole in the middle of one of the four slots. Bolt the bracket to the tank through this hole before drilling the next hole. After each hole is drilled, bolt the bracket to the tank before drilling the next hole. This will ensure that the mounting holes align well with the slots in the bracket.

Use 1/2-inch hard steel bolts to mount the bracket to the tank. The bolts must be quite tight to keep the end bracket from slipping. Welding the heads of these mounting bolts to the inside of the tank will prevent the bolts from turning while loosening and tightening them during the

adjustment procedure. Experience has shown that leakage through these bolt holes is very slight, and no sealing should be required.

## Mounting frame for tank

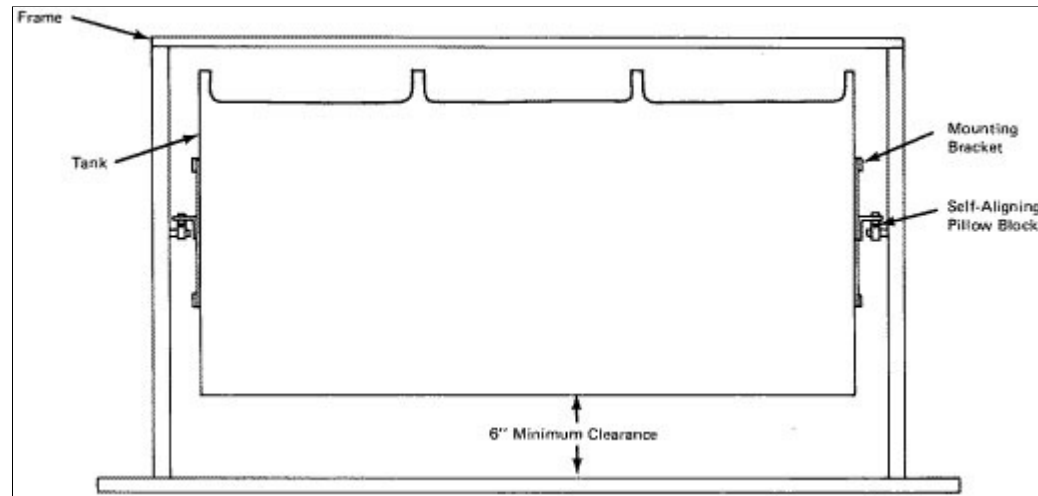

**Figure 5**  
Mounting frame for tank.

The axle the tank pivots on at either end is rigidly mounted to an external frame (Figure 5).

The diameter of the axle should be 1-1/8 inches for tanks up to 450 gallons in volume. This frame can be in any shape that will hold the axle in a rigid position. When the tank is installed and removed from the frame, the pillow blocks are unbolted from the end brackets and remain on the axles.

## Installing foam plastic insulation

Along the back edge of the discharge opening in the tank, bolt a strip of foam plastic insulation sized 4" x 4" x length of tank. The size of the foam strip and precise position in the tank is not critical. The foam plastic insulation is to displace water to the front of the full tank, causing the tank to dump forward.

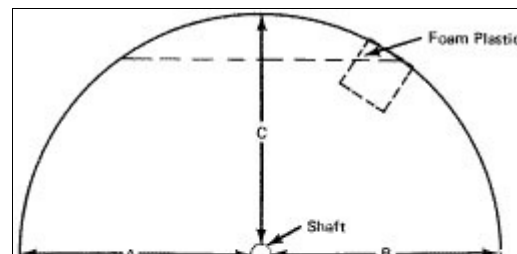

**Figure 6**  
Measuring detail for adjustment.

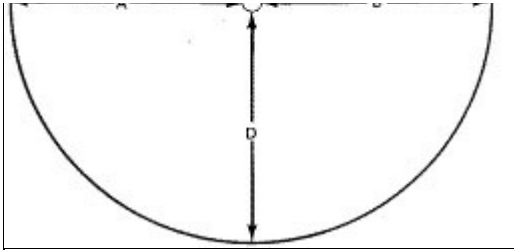

## Adjusting pivot points for automatic dumping

After installing the foam plastic insulation and mounting the tank in the supporting frame, you can adjust the pivot points. Refer to Figure 6 for adjustment.

Dimensions A, B, C and D are taken from the pivot shaft to the outside edge of the tank. Initially, measurements A and B should be equal, and C and D should be equal. This places the pivot point in the center of the tank. Fill the tank with water. With the pivot points in this position, the tank probably will be too stable and will not dump in either direction. Decrease dimension D in 1/2-inch increments until the tank will begin to rotate forward or backward when it is about half full.

If the tank rotates forward, decrease dimension A in 1/16-inch increments until the tank begins to rotate backward when it is about half full. Be sure that all dimensions (A,D, etc.) have the same value on both ends of the tank during the adjustment procedure. This will keep the tank from wobbling in the frame as it rotates and simplifies the adjustment procedure. After each adjustment, be sure to tighten the four mounting bolts enough to prevent slippage. This will keep you from getting too frustrated when adjusting for automatic dumping.

As the tank begins to rotate backward at about half-full condition, the foam insulation will become immersed in water. As it displaces water to the front of the tank, the tank rotates forward during the remainder of the filling cycle. As the discharge opening returns to the "top" position and the tank is nearly full, further displacement of water by the plastic foam should cause the tank to tip forward and dump. If this does not occur, increase dimension A very slightly until forward dumping occurs at about the full position. As the tank dumps, it should rotate forward far enough to discharge all the water.

The tank may or may not spin completely through a 360 degree circle. Experience has shown that tanks of this type should accomplish automatic dumping within five "adjustments." A method of rapidly filling the tank with water will speed up the adjustment process.

## Setting the tank in the flushing gutter

The tank may be placed over the flushing gutter so that it dumps forward down the gutter or back against the wall. Excessive splashing may occur if the tank dumps back against the wall and not enough clearance is provided to let the water get away.

## Advantages

This type of tank is fairly simple to construct. In most cases, the tank itself should be available commercially, and construction of the end brackets and mounting frame is fairly straightforward. If the tank is well made, it should have no leakage problems for a long time. Limited experience indicates that maintenance is low on this type of tank. Cost will depend largely on the price of labor for construction, but it should be competitive with other alternatives.

## Disadvantages

Disadvantages of the spin-through flush tank include difficulty in precisely adjusting tank volume to the flush volume required for a particular gutter. This is because commercially available tanks come in standard sizes that may or may not precisely fit a particular situation. However, as long as at least the minimum required flush volume is contained in the tank, the gutter should clean.

Another possible disadvantage is uncontrolled release of flush water. This tank will discharge in 1 to 2 seconds rather than the ideal 10 seconds necessary to match tank discharge rate to gutter flow rate. Experience at this point indicates that this discrepancy does not interfere with gutter cleaning.

Conditions that change balance characteristics could limit the tank's effectiveness. This might include outdoor installations where ice builds up on the tank in the winter.

G1927, reviewed October 1993

## Related MU Extension publications

- G1830, Tip Tank for Flushing Dairy Free-Stall Alleys  
<http://extension.missouri.edu/publications/DisplayPub.aspx?P=G1830>
- WQ308, Flushing Systems for Dairies  
<http://extension.missouri.edu/publications/DisplayPub.aspx?P=WQ308>
- WQ314, Basic Requirements for Flushing Dairies  
<http://extension.missouri.edu/publications/DisplayPub.aspx?P=WQ314>
- WQ315, Tip Tanks for Dairy Flushing  
<http://extension.missouri.edu/publications/DisplayPub.aspx?P=WQ315>
- WQ316, Siphon Tanks for Dairy Flushing  
<http://extension.missouri.edu/publications/DisplayPub.aspx?P=WQ316>
- WQ317, Pipeline/Valve Systems for Flushing Dairies  
<http://extension.missouri.edu/publications/DisplayPub.aspx?P=WQ317>

- WQ318, Vertical Dams and Trapdoor Tanks for Dairy Flushing  
<http://extension.missouri.edu/publications/DisplayPub.aspx?P=WQ318>

Order publications online at <http://extension.missouri.edu/explore/shop/> or call toll-free 800-292-0969.



■ Issued in furtherance of the Cooperative Extension Work Acts of May 8 and June 30, 1914, in cooperation with the United States Department of Agriculture. Director, Cooperative Extension, University of Missouri, Columbia, MO 65211  
■ an equal opportunity/ADA institution ■ 573-882-7216 ■ [extension.missouri.edu](http://extension.missouri.edu)