

University of Missouri Extension

WQ325, New August 1995

Picket Dam Storage for Dairy Manure

Charles D. Fulhage

Department of Agricultural Engineering

Dairy manure can be handled as a solid, semi-solid, slurry or dilute liquid such as a lagoon. Solid dairy manure contains significant amounts of bedding and no added water, so that the resulting material will stack, and it can be handled easily with conventional manure equipment (front-end loaders and beater-type spreaders).

Slurry manure contains the solid and liquid portions of dairy manure, is fluid in nature and will not stack. Slurry manure has little or no bedding, and is usually collected in manure tanks, either above-ground, or sometimes under slats. Pumps and tankwagons are required for the handling and spreading of slurry manure, due to its fluid characteristics.

Dairy manure collected and treated in a lagoon is highly fluid and is best handled with irrigation equipment.

Semi-solid dairy manure contains small amounts of bedding, which may be typical in a freestall facility, and can usually be handled as solid if no additional water is allowed to collect or mix with the manure. Picket-dam facilities have proven useful for storing semi-solid dairy manure. Their design allows excess water from rainfall or other sources to drain away so that the material can be handled with conventional equipment. Manure cannot be expected to "dry out" or dewater in a picket-dam facility. The picket dam is effective only in draining away free water, such as rainfall or runoff water from the manure.

Advantages of a picket dam

Several advantages have been noted in the use of picket-dam storage structures for dairy manure.

- Handling manure as a semi-solid in a picket-dam facility allows the use of conventional manure equipment such as front-end loaders and beater-type manure spreaders.
- Other solid manure containing bedding, such as manure from maternity or sick pens or calf pens and hutches, can be handled in the same facility.
- Handling manure as a semi-solid and draining away excess water from rainfall or other sources, reduces the total volume of material that must be hauled.
- A picket-dam storage structure can be built to accumulate manure for several weeks or even months. Such a storage period allows flexibility

in the manure-hauling schedule, and daily hauling is not required.

Requirements for a successful picket dam

Experience with picket dams has shown that certain management techniques are necessary for best performance.

- Small to moderate amounts of bedding are needed in the manure. This amount of bedding gives the manure a semi-solid consistency without being too liquid and "runny." Semi-solid manure will "slump" away from the loading point so that more manure can be added to the storage. The small amount of bedding normally kicked out of freestalls usually results in manure of the proper consistency for picket-dam storages if no other water is allowed to mix with the manure.
- Milking center wash water must be kept out of the picket-dam storage. An appropriate holding pond or grass filter should be established to receive milking center waste. Mixing this water with manure in the picket-dam storage will cause the contents to be too liquid.
- To the extent possible, surface runoff from lot areas should be directed to a lagoon, holding pond or appropriate grass filter, and not routed through the picket-dam storage. This will help the manure retain the ideal semi-solid consistency.
- Rainwater falling directly on the picket-dam storage should be drained away. This is accomplished by proper design of the facility.
- Experience has shown picket-dam facilities to be best suited for small to moderately sized dairies, since manure handling is somewhat labor-intensive. Larger dairies generally employ flushing or other means of manure collection and transport requiring less labor.

Design considerations for picket-dam storages

Several design considerations and requirements are necessary in order to optimize performance of the facility.

Loading

Loading a picket-dam storage facility is usually accomplished by scraping and pushing manure into the facility via a pushoff ramp, or off a vertical wall along one side. Figure 3 is a schematic of a picket-dam facility loaded in this manner. Experience has shown that manure can build up in front of a pushoff ramp during freezing conditions. The capability to load the facility along one entire side rather than at a single point (pushoff ramp) reduces such problems. If significant amounts of runoff water are likely to enter the unit, the approach should be shaped with a slight dip to intercept runoff water and direct it around the facility, as shown in Figure 1. Manure can still be pushed up the slight incline to the pushoff area. Picket-dam facilities also can be loaded with mechanical devices designed to handle semi-solid manure, such as large piston pumps or conveyor-type barn cleaners.

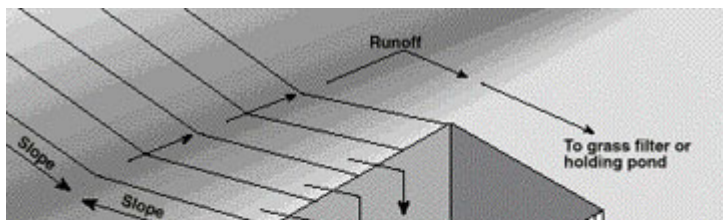
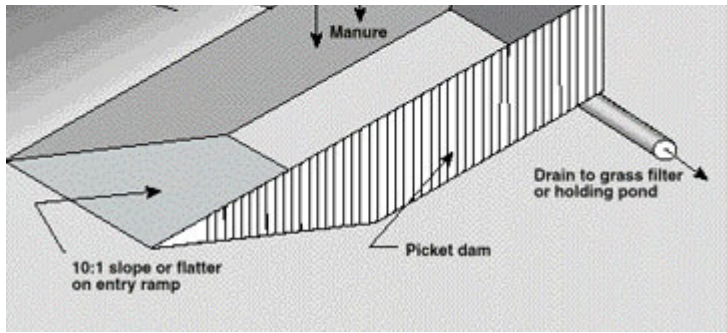

Figure 1

A picket dam facility with a slight dip in the approach can intercept runoff water and direct it around the facility.



Picket dam location

The location of the picket dam within the storage facility is very important. It should be located at the position furthest away from the loading point, or in the section that manure reaches last as the storage fills up. This allows the natural slope of the manure surface to shed water toward the picket dam. The picket dam also should be at the place from which manure is first removed from the facility during load out. Thus, the dam should be adjacent to or extending up the entry ramp used for load out. Removing manure from the

picket-dam area first prevents pockets forming that may collect rainwater.

Storage structure

Concrete is the preferred construction material for picket-dam storages. Advantages of concrete include durability, all-weather use capability, and the ability to form loading or pushoff walls, bucking walls and an impermeable barrier for the manure. Picket dams have been successfully used in earthen-walled structures, but total cleanout is more difficult due to the sloping earth walls. It is more difficult to structurally integrate the picket dam itself into the earthen walls. An earthen-walled picket-dam structure must have a concrete entry ramp and concrete bottom to avoid scouring as manure is removed.

The concrete entry ramp into the storage should have a maximum 10:1 slope, as shown in Figure 2, and 15:1 is preferred for ease of entry and exit. Some producers prefer having the entry ramp wide enough (40 feet) to park a manure spreader on the ramp while it is being loaded. The entry ramp should be roughened to aid traction during unloading operations. Small channels (3/4-inch x 3/4-inch, 6-inch on-center) cut into the concrete before it sets up will improve traction and drain water toward the picket dam, if they are cut at an angle to slope downhill toward the picket dam. The entry ramp and concrete floor should be placed on a gravel base or compacted fill to prevent settling. The concrete should have at least 3,500 psi compressive strength, and be a minimum of 5 inches thick to support the full spreader and tractor loads which will be imposed. Consider using steel reinforcing to prevent separation due to cracking. Place number 3 (3/8-inch diameter) bars 24 inches on-center, both ways, supported so that they will be in the center of the poured slab (Figure 2). The floor of the structure should be flat, with very little or no slope toward the picket dam. Slope toward the picket dam may cause undesirable manure flow in that direction.

Concrete walls in a manure-storage facility must be designed with adequate strength and reinforcing to withstand loads due to saturated soil outside the wall, pressure of manure inside the wall and any mechanical forces, such as a front end loader pushing manure against the wall. Detailed wall design requires an analysis of the loads which will be present, and selection of adequate concrete and reinforcing to withstand the loads. All potential wall heights and loading conditions cannot be evaluated in this guide. However, Figure 3 is a design for walls up to 6 feet in height which are "free-standing" (the top of the wall is not restrained or tied into another slab). If the top of the wall is tied into another slab, as might be the case on the side where manure is pushed over the wall into the facility, the wall design shown in Figure 4 is adequate.



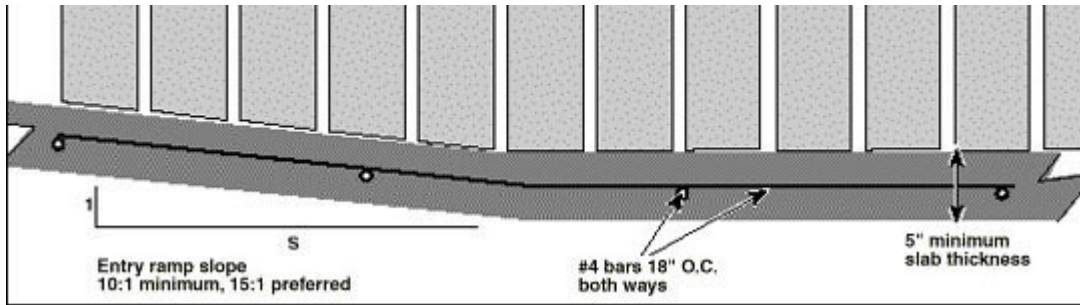

Figure 2
Side view of a concrete entry ramp with 10:1 slope

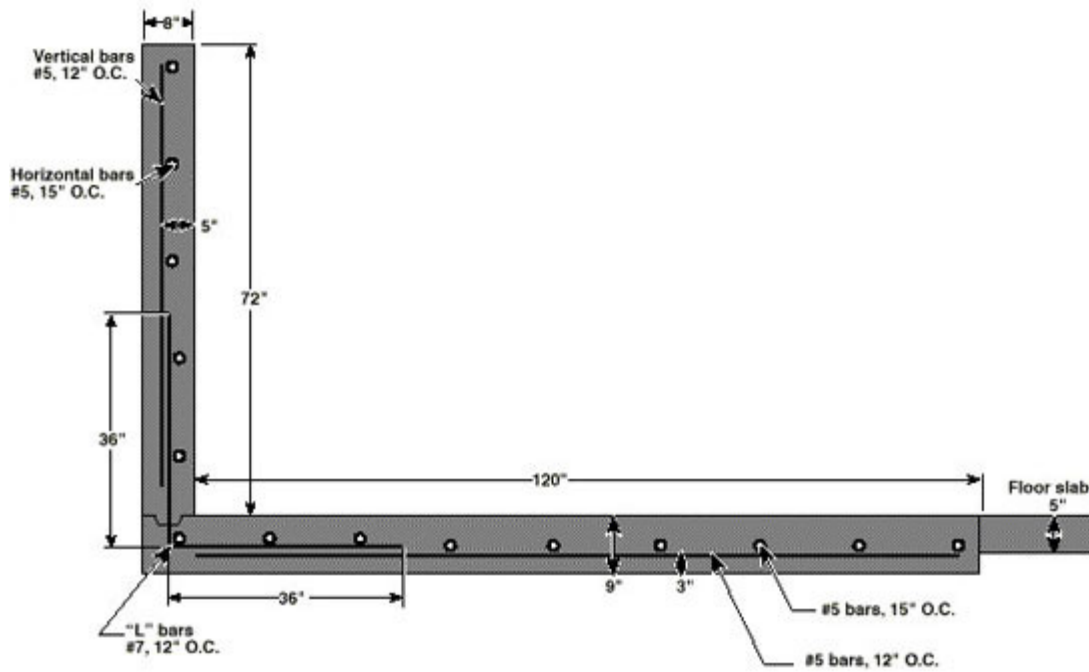

Figure 3
Design for a six-foot free-standing concrete wall

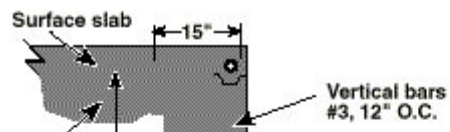
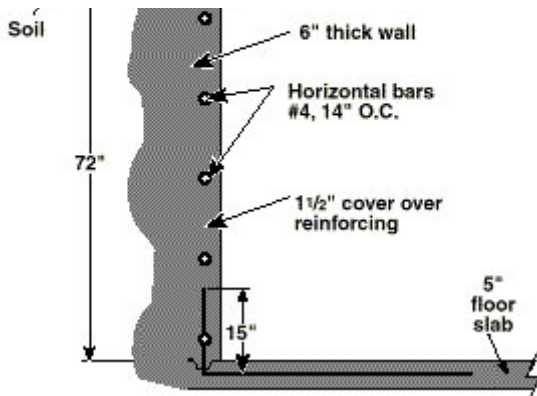

Figure 4
Design for a concrete wall tied into another slab.



Picket dam design

The picket dam must be constructed to withstand the pressure of manure in the facility when it is full. Figure 5 is a schematic of typical construction details for a picket dam. The primary structural supports for the picket dam are treated wood posts set a minimum of 4 feet in the ground. Post size and spacing is adjusted according to wall height. Table 1 gives details on post selection and spacing for picket dams. Figure 6 shows a method of reinforcement for the posts in the concrete floor.

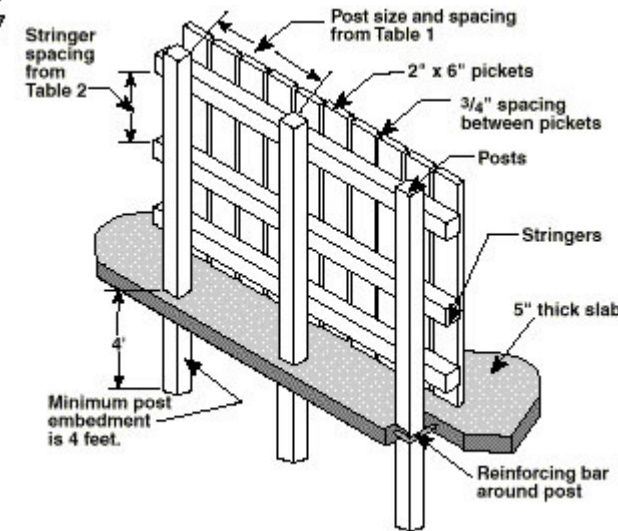

Figure 5
Typical construction details of a picket dam.

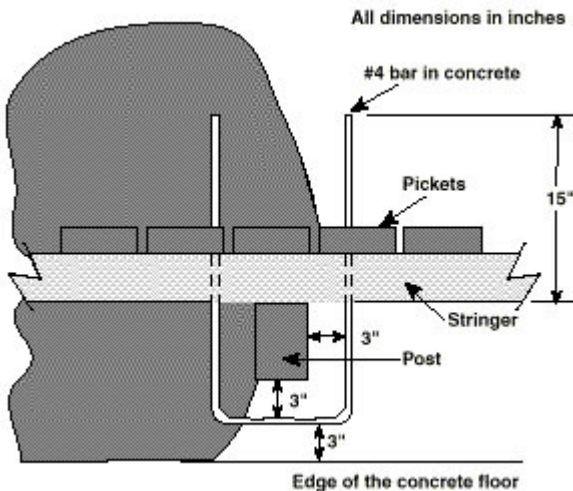

Figure 6
Reinforcement for posts in a concrete floor.

Table 1

Post size and spacing for picket dams.

Wall height	Post size	Spacing
0 feet to 4 feet	4 inches x 6 inches	5 feet
5 feet	6 inches x 6 inches	4 feet
6 feet	6 inches x 8 inches	4 feet
7 feet	8 inches x 8 inches	3 feet

Horizontal 4- by 4-inch treated wood stringers are attached to the posts at appropriate spacings, according to the height of the picket dam. These supports are closer together near the bottom of the wall where fluid pressures are highest, and farther apart near the top. Table 2 gives proper spacings for horizontal supports or stringers.

Table 2

Spacing for horizontal stringers in picket dams.

Depth ¹	Size	Spacing
0 feet to 4 feet	4 inches x 4 inches	36 inches
4 feet to 6 feet	4 inches x 4 inches	24 inches
6 feet to 8 feet	4 inches x 4 inches	18 inches

¹Depth below maximum manure level (top of wall).

Note

Lowest stringer should be within 10 inches of floor. Stringers can be fastened to posts with 1/2-inch galvanized bolts.

Vertical 2- by 6-inch treated wood pickets are attached to the horizontal treated wood stringers. Three-fourths-inch openings between the pickets allow water to drain through the dam. A 1.5-inch deep groove can be cast in the concrete floor as a receptacle for the bottom edge of the pickets, if desired. This will support the bottom edge of the pickets and minimize damage from accidental contact with the loader bucket.

Drainage from the picket dam must be contained or managed so that there is no pollution. The drainage is usually collected in a holding pond, or lagoon, or discharged onto a properly-sized vegetated grass filter strip. Figure 7 shows how drainage from a picket dam may flow directly into a holding pond, or how a collection trough and pipe can be used to route the drainage to a pond located further away. If a pipe or sewer line is used to carry the drainage to a holding pond, it should have cleanouts installed every 50 feet to 100 feet to aid in solving plugging problems.

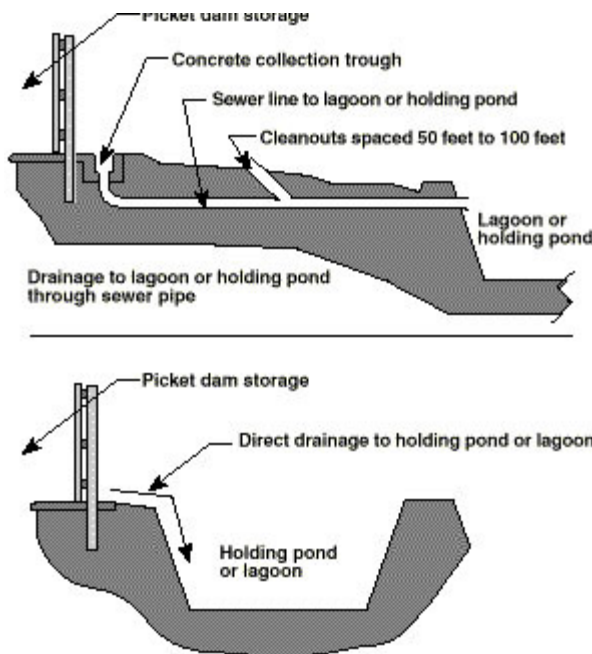
**Figure 7**

Drainage from a picket dam may flow directly into a holding pond (bottom view) or a collection trough and pipe (top view) may route drainage to a pond located further away.

If the picket-dam storage is too low to allow gravity drainage to the holding pond, a collection sump and pump may be used. However, this situation should be avoided, if at all possible, because of the expense and maintenance necessary to install and operate a reliable pumping system.

Management of a picket-dam storage

Picket-dam storages are usually loaded with manure daily as part of the regular cleanup chores. Manure containing a small amount of bedding works best in picket dams. Manure should be pushed into the storage at the point or side furthest from the picket dam. Care should be taken to minimize the amount of "free" water (runoff, parlor wash water, leaking waterers) entering the storage.

Drainage from the picket-dam storage is highly polluted, and cannot be allowed to enter a stream or watercourse, or discharge from the property. Therefore, the drainage should be collected in a holding pond or lagoon, or applied to a suitable grass filter strip. A lagoon or holding pond used to collect lot runoff and/or milkhouse wash water may also be used to receive drainage from the picket dam.

Manure removal from picket-dam storages is usually accomplished with conventional manure spreaders and front-end or skid-steer loaders. Some fine solids tend to accumulate immediately behind the pickets, and should be removed when the facility is cleaned. The gaps between the pickets tend to become plugged by manure pressure and cleaning operations. These vertical slots should be cleaned, if necessary, after the facility is emptied so that good drainage can occur.

Haul and land-apply manure to correspond with the growing season of the crop, when possible. Follow best management practices in matching

manure nutrients to the fertilizer needs of the crop. Soil tests and manure nutrient analyses aid in determining proper manure application rates. Inject or incorporate manure soon after spreading to save nutrients and reduce odor. Consider wind direction and location of neighbors when spreading manure. Try not to spread on humid, still days when manure odors can carry longer distances without being diluted.

Sizing a picket-dam storage

The size of a picket-dam storage facility depends upon the number of animals served, the portion of total manure production scraped into the storage and the length of time or storage period between cleanouts. Most dairy operations will need a minimum of three months storage, and six months is more ideal. Table 3 gives the fraction of total manure production expected in the various parts of the facility.

Figures in Table 3 can be used to size a picket-dam storage as shown in the following example.

Table 3

Percentage of total manure production in each part of a dairy production system.

	Percentage of total manure production
Milking parlor	10 percent
Holding pen	25 percent
Feeding are	40 percent
Loafing area	25 percent

Total manure production = 1.32 cubic feet per day per 1,000 pounds animal weight.

Example

Calculate the size picket-dam storage required to store manure produced in a 60-cow dairy for 120 days. Only manure from the freestall barn (feeding and loafing areas) will be scraped into the storage. Average cow weight is 1,400 pounds

Number of thousand weights = $60 \times 1.4 = 84$ thousand weights

Required volume = thousand weights x total production x percentage x days storage = $84 \times 1.32 \times 0.65 \times 120 = 8,649$ cu. feet

Dimensions for a picket-dam storage with the shape shown in Figure 8 can be obtained using the equation shown. Assume the storage will be 40 feet wide, and 4 feet deep, with a 10:1 slope on the entry ramp. From the equation shown, the bottom length is calculated as follows.

$$\text{Bottom length} = \frac{(8,649)}{40 \times 4} - \frac{(4 \times 10)}{2} = 34 \text{ feet}$$



Figure 8

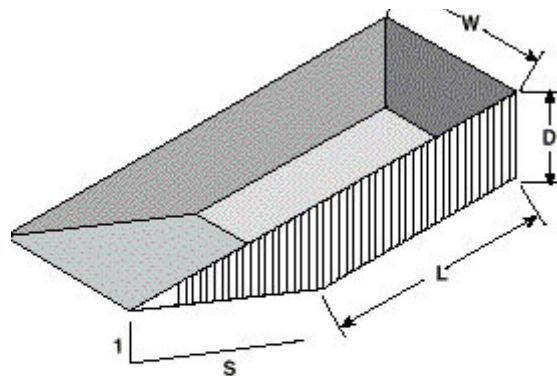

Dimension equation for a picket-dam storage facility.

V = Storage volume cubic feet W = Width in feet
 L = Bottom length in feet D = Depth in feet
 S = Entry ramp slope, feet/feet

$$L = \frac{V}{W \times D} - \frac{D \times S}{2}$$

References

- *Picket Dam for Draining Water From Uncovered Manure Storage*. Cooperative Extension Bulletin, Michigan State University, Lansing Michigan.
- Picket Dam Manure Storage. Harrington, R.M. and R.W. Prange, Massachusetts Cooperative Extension Service and Natural Resources Conservation Service.
- Solid Manure Handling for Livestock. Bruns, E.G. and J.W. Crowley, University of Wisconsin Extension, Madison, Wisconsin.

WQ325, new August 1995

Related MU Extension publications

- EQ301, Dairy Manure Management Systems in Missouri
<http://extension.missouri.edu/publications/DisplayPub.aspx?P=EQ301>

Order publications online at <http://extension.missouri.edu/explore/shop/> or call toll-free 800-292-0969.