

The problem of deficiency indices for discrete Schrödinger operators on locally finite graphs

Sylvain Golénia and Christoph Schumacher

Citation: *J. Math. Phys.* **52**, 063512 (2011); doi: 10.1063/1.3596179

View online: <http://dx.doi.org/10.1063/1.3596179>

View Table of Contents: <http://jmp.aip.org/resource/1/JMAPAQ/v52/i6>

Published by the [American Institute of Physics](#).

Related Articles

Darboux transformations for (1+2)-dimensional Fokker-Planck equations with constant diffusion matrix
J. Math. Phys. **53**, 103519 (2012)

The rigged Hilbert space approach to the Gamow states
J. Math. Phys. **53**, 102113 (2012)

Scattering of a spinless particle by an asymmetric Hulthén potential within the effective mass formalism
J. Math. Phys. **53**, 102111 (2012)

Quantum mechanics in fractional and other anomalous spacetimes
J. Math. Phys. **53**, 102110 (2012)

Levinson's theorem for graphs II
J. Math. Phys. **53**, 102207 (2012)

Additional information on J. Math. Phys.

Journal Homepage: <http://jmp.aip.org/>

Journal Information: http://jmp.aip.org/about/about_the_journal

Top downloads: http://jmp.aip.org/features/most_downloaded

Information for Authors: <http://jmp.aip.org/authors>

ADVERTISEMENT

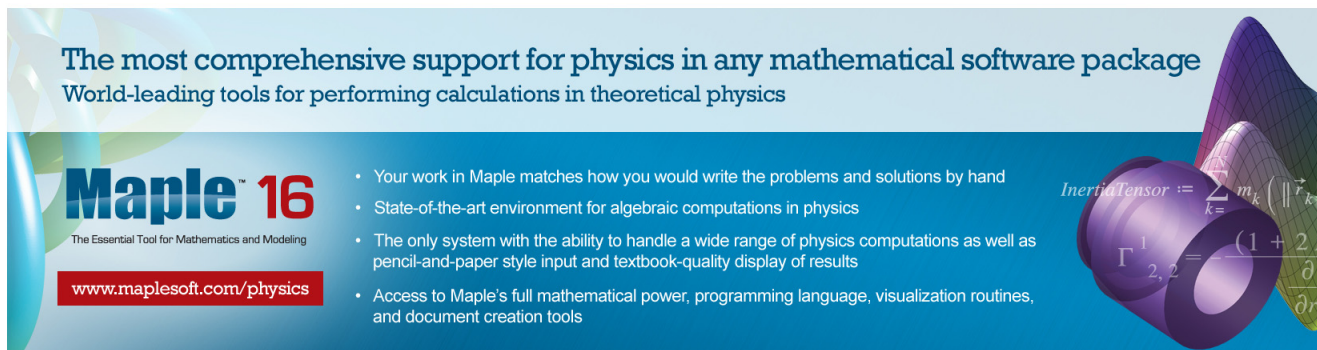

The most comprehensive support for physics in any mathematical software package
World-leading tools for performing calculations in theoretical physics

Maple 16
The Essential Tool for Mathematics and Modeling
www.maplesoft.com/physics

- Your work in Maple matches how you would write the problems and solutions by hand
- State-of-the-art environment for algebraic computations in physics
- The only system with the ability to handle a wide range of physics computations as well as pencil-and-paper style input and textbook-quality display of results
- Access to Maple's full mathematical power, programming language, visualization routines, and document creation tools

InertiaTensor := $\sum_{k=1}^n m_k \left(\|\vec{r}_k\|^2 \mathbf{1} - \vec{r}_k \vec{r}_k^T \right)$

$\Gamma_{2,2}^1 = \frac{(1+2)}{\partial r}$

The problem of deficiency indices for discrete Schrödinger operators on locally finite graphs

Sylvain Golénia^{1,a)} and Christoph Schumacher^{2,b)}

¹*Mathematisches Institut der Universität Erlangen-Nürnberg, Bismarckstr. 11/2, 91054 Erlangen, Germany and Institut de Mathématiques de Bordeaux, Université Bordeaux I, 351 cours de la Libération, 33405 Talence cedex, France*

²*Fakultät für Mathematik der Technischen Universität Chemnitz, Reichenhainer Str. 41, 09126 Chemnitz, Germany*

(Received 24 November 2010; accepted 10 May 2011; published online 24 June 2011)

The number of self-adjoint extensions of a symmetric operator acting on a complex Hilbert space is characterized by its deficiency indices. Given a locally finite unoriented simple tree, we prove that the deficiency indices of any discrete Schrödinger operator are either null or infinite. We also prove that all deterministic discrete Schrödinger operators which act on a random tree are almost surely self-adjoint. Furthermore, we provide several criteria of essential self-adjointness. We also address some importance to the case of the adjacency matrix and conjecture that, given a locally finite unoriented simple graph, its deficiency indices are either null or infinite. Besides that, we consider some generalizations of trees and weighted graphs. © 2011 American Institute of Physics. [doi:10.1063/1.3596179]

I. INTRODUCTION

The spectral theory of adjacency matrices acting on graphs is useful for the study, among others, of some gelling polymers, of some electrical networks, and in number theory, e.g., Refs. 7–9, and 16. In quantum physics, proving that a symmetric operator is self-adjoint is a central problem. To characterize all the possible extensions, one studies the so-called deficiency indices.

We start with some definitions to fix notation for graphs and refer to Refs. 4, 5, and 17 for surveys on the matter. Let V be a countable set. We equip V with the discrete topology. Let $E := V \times V \rightarrow [0, \infty)$ and assume that $E(x, y) = E(y, x)$, for all $x, y \in V$. We say that $G := (E, V)$ is an unoriented weighted graph with *vertices* V and *weights* E . In the setting of electrical networks, the weights correspond to the conductances. We say that $x, y \in V$ are *neighbors* if $E(x, y) \neq 0$ and denote it by $x \sim y$. We say there is a *loop* in $x \in V$ if $E(x, x) \neq 0$. A graph G is *simple* if it has no loops and E has values in $\{0, 1\}$. The set of *neighbors* of $x \in E$ is denoted by $\mathcal{N}_G(x) := \{y \in E \mid x \sim y\}$. Given $X \subseteq V$ we write $\mathcal{N}_G(X) := \bigcup_{x \in X} \mathcal{N}_G(x)$. The *degree* of $x \in V$ is by definition $d_G(x) := |\mathcal{N}_G(x)|$, the number of neighbors of x . The graph is of *bounded degree*, if $\sup_{x \in V} d_G(x)$ is finite. A graph is *locally finite* if $d_G(x)$ is finite for all $x \in V$. A graph is *connected*, if for all $x, y \in V$, there exists an x - y -*path*, i.e., there is a finite sequence $(x_1, \dots, x_n) \in V^{N+1}$ such that $x_1 = x$, $x_{N+1} = y$ and $x_n \sim x_{n+1}$, for all $n \in \{1, \dots, N\}$. In this case, we endow V with the metric ρ_V defined by $\rho_V(x, y) := \inf\{n \in \mathbb{N} \mid \text{there exists an } x\text{-}y\text{-path of length } n\}$. Note that in this paper we use \mathbb{N} for the set of nonpositive integers, i.e., $0 \in \mathbb{N}$. In the sequel, all graphs are supposed to be locally finite, with no loops and unoriented.

We associate to G the complex Hilbert space $\ell^2(V)$. We denote by $\langle \cdot, \cdot \rangle$ and by $\|\cdot\|$ the scalar product and the associated norm, respectively. By abuse of notation, we denote the space simply by $\ell^2(G)$. The set of complex functions with compact support in V is denoted by $\mathcal{C}_c(G)$. One often

^{a)}Electronic mail: sylvain.golenia@u-bordeaux1.fr.

^{b)}Electronic mail: christoph.schumacher@mathematik.tu-chemnitz.de.

considers the *Laplacian* defined by

$$(\Delta_{G,\circ}f)(x) := \sum_{y \sim x} E(x, y)(f(x) - f(y)), \text{ with } f \in \mathcal{C}_c(G) \quad (1.1)$$

and the so-called *adjacency matrix*,

$$(\mathcal{A}_{G,\circ}f)(x) := \sum_{y \sim x} E(x, y)f(y), \text{ with } f \in \mathcal{C}_c(G). \quad (1.2)$$

Both of them are symmetric and thus closable. We denote the closures by Δ_G and \mathcal{A}_G , their domains by $\mathcal{D}(\Delta_G)$ and $\mathcal{D}(\mathcal{A}_G)$, and their adjoints by $(\Delta_G)^*$ and $(\mathcal{A}_G)^*$, respectively. In Ref. 20, see also Ref. 12, it is shown that the operator Δ_G is essentially self-adjoint on $\mathcal{C}_c(G)$, when the graph is simple. In particular, one has that $\Delta_G = (\Delta_G)^*$. In contrast, even in the case of a locally finite tree G , \mathcal{A}_G may have many self-adjoint extensions, see Refs. 11, 16, and 18 and Proposition 1.2 for concrete examples. We mention also the work (Ref. 2) where a characterization in terms of limit point – limit circle is given.

In this note, we are also interested in the *discrete Schrödinger operators* $\mathcal{A}_G + \mathcal{V}$ and $\Delta_G + \mathcal{V}$ with *potential* $\mathcal{V} := V \rightarrow \mathbb{R}$, where \mathcal{V} also denotes the operator of multiplication with the function \mathcal{V} . The operators are defined as the closures of $\mathcal{A}_{G,\circ} + \mathcal{V}$ and of $\Delta_{G,\circ} + \mathcal{V}$ on $\mathcal{C}_c(G)$, respectively. Note that Δ_G , up to sign, is in fact a discrete Schrödinger operator formed with the help of \mathcal{A}_G ,

$$\Delta_G = \mathcal{V} - \mathcal{A}_G, \text{ where } \mathcal{V}(x) := \sum_{y \sim x} E(x, y). \quad (1.3)$$

In the sequel, we investigate the number of possible self-adjoint extensions of discrete Schrödinger operators by computing their deficiency indices. Given a closed and densely defined symmetric operator T acting on a complex Hilbert space, the deficiency indices of T are defined by $\eta_{\pm}(T) := \dimker(T^* \mp i) \in \mathbb{N} \cup \{+\infty\}$. We recall some well-known facts. The operator T possesses a self-adjoint extension if and only if $\eta_+(T) = \eta_-(T)$. If this is the case, we denote the common value by $\eta(T)$. T is self-adjoint if and only if $\eta(T) = 0$. Moreover, if $\eta(T)$ is finite, the self-adjoint extensions can be explicitly parametrized by the unitary group $U(n)$ in dimension $n = \eta(T)$. Using the Krein formula, it follows that the absolutely continuous spectrum of all self-adjoint extensions is the same.

Since the operator $\mathcal{A}_G + \mathcal{V}$ commutes with the complex conjugation, its deficiency indices are equal, e.g., [Ref. 19, Theorem 10.3]. We denote by $\eta(G)$ the common value, when $\mathcal{V} = 0$. This means that $\mathcal{A}_G + \mathcal{V}$ possesses a self-adjoint extension. Remark that $\eta(\mathcal{A}_G + \mathcal{V}) = 0$ (respectively $\eta(\Delta_G + \mathcal{V}) = 0$) if and only if $\mathcal{A}_G + \mathcal{V}$ (respectively $\Delta_G + \mathcal{V}$) is essentially self-adjoint on $\mathcal{C}_c(G)$. We give the following criteria for essential self-adjointness:

Proposition 1.1: Let $G = (E, V)$ be a locally finite graph and $\mathcal{V} : V \rightarrow \mathbb{R}$ be a potential. Then, the following assertions hold true:

1. Provided that \mathcal{V} is bounded from below, $\Delta_G + \mathcal{V}$ is essentially self-adjoint on $\mathcal{C}_c(G)$.
2. Let $x_0 \in V$, set $b_i := \sup\{\sum_{x,y} E(x, y) \mid \rho_V(x_0, x) = i \text{ and } \rho_V(x_0, y) = i + 1\}$, and take $\mathcal{V} : V \rightarrow \mathbb{R}$. If $\sum_{i \in \mathbb{N}} 1/b_i = +\infty$, then $\mathcal{A}_G + \mathcal{V}$ and $\Delta_G + \mathcal{V}$ is essentially self-adjoint on $\mathcal{C}_c(G)$.
3. Suppose that $\sup_x \max_{y \sim x} |d_G(x) - d_G(y)| < \infty$, E is bounded, and $\sup_{x \in V} |\mathcal{V}(x)/d_G(x)| < \infty$, then $\mathcal{A}_G + \mathcal{V}$ is essentially self-adjoint on $\mathcal{C}_c(G)$.
4. Suppose that d_G is bounded, $\sup_x \max_{y \sim x} |E(x) - E(y)| < \infty$, where $E(x) := \max_{y \sim x} E(x, y)$, and that $\sup_{x \in V} |\mathcal{V}(x)/E(x)| < \infty$, then $\mathcal{A}_G + \mathcal{V}$ is essentially self-adjoint on $\mathcal{C}_c(G)$.
5. Suppose there is a compact set $K \subset V$, such that $\sum_{y \sim x} E^2(x, y)d_G(y) \leq \mathcal{V}^2(x)$ for all $x \notin K$. Then $\mathcal{A}_G + \mathcal{V}$ is essentially self-adjoint on $\mathcal{C}_c(G)$.
6. Suppose there is a compact set $K \subset V$, such that $\sum_{y \sim x} E^2(x, y)(1 + d_G(y)) \leq \mathcal{V}^2(x)$ for all $x \notin K$, then $\Delta_G + \mathcal{V}$ is essentially self-adjoint on $\mathcal{C}_c(G)$.

We prove the result in Sec. II B. The first point is the discrete version of the fact that given a non-negative potential $\mathcal{V} \in L^2_{\text{loc}}(\mathbb{R}^n)$, one has that $-\Delta_{\mathbb{R}^n} + \mathcal{V}$ is essentially self-adjoint on $\mathcal{C}_c(\mathbb{R}^n)$, e.g., [Ref. 19, Theorem 10.28]. It is essentially a repetition of [Ref. 20, Theorem 1.3.1]. The second point

is a Carleman-type condition, see, for instance, [Ref. 3, page 504] for the case of Jacobi matrices. We stress that this result holds true without any hypothesis of size or of sign on the potential part. In particular, the Schrödinger operators could be unbounded from below and from above, see Ref. 11, for instance. Unlike in Ref. 3, we rely on an commutator approach, see Refs. 21 and 22 for similar techniques. The points (3) and (4) follow by application of the Nelson commutator Theorem. The last two ones are an application of Wüst's Theorem by considering \mathcal{A} and Δ as perturbation of the potential. We mention the works of Refs. 6, 13, and 15 on related questions.

Concentrate a moment on the case of the adjacency matrix for simple graphs. Keep in mind, it is no gentle perturbation of the Laplacian, see Proposition 2.1. In Refs. 16 and 18, adjacency matrices for simple trees with positive deficiency indices are constructed. In fact, it follows from the proof that the deficiency indices are infinite in both references. We recall that a *tree* is a connected graph $G = (E, V)$ such that for each edge $e \in V \times V$ with $E(e) \neq 0$ the graph (\tilde{E}, V) , with $\tilde{E} := E \times 1_{\{e\}^c}$, i.e., with e removed, is disconnected. As a general result, a special case of Theorem 1.1 gives that, given a locally finite simple tree G , one has

$$\eta(G) \in \{0, +\infty\}. \quad (1.4)$$

This is a new result to our knowledge, although the literature on trees is extensive. We believe that, given a simple graph $G = (E, V)$, or more generally, a graph with bounded weights, (1.4) should be true. In Remark 2.2, we explain that it is enough to prove (1.4) for simple bi-partite graphs. We recall that a *bi-partite* graph is a graph so that its vertex set can be partitioned into two subsets in such a way that no two points in the same subset are neighbors. Trees are bi-partite for instance. We stress that this conjecture is false if one takes unbounded weights, see, for instance, counter-examples of adjacency matrices given by Jacobi matrices in [Ref. 11, Remark 2.1] and also in Ref. 16.

We now point out that the self-adjointness of the adjacency matrix, acting on a simple locally finite tree G , is linked with the growth of the offspring, i.e., of the number of sons. (We refer to Sec. III A for precise definitions concerning trees.) When the latter grows up to linearly, Proposition 1.1 gives that $\eta(G) = 0$. On the other hand, if the growth is "exponential," Proposition 3.1 assures that $\eta(G) = \infty$. In Sec. III B, using invariant spaces, we prove the following sharp result.

Proposition 1.2: Let $\alpha > 0$ and G be a tree with offspring $\lfloor n^\alpha \rfloor$ per individual at generation n . Then, one obtains

$$\eta(G) = \begin{cases} 0, & \text{if } \alpha \leq 2, \\ +\infty, & \text{if } \alpha > 2. \end{cases}$$

We come back to the general question for Schrödinger operators and give our main result in the context of trees. We prove it in Sec. III E and generalize it in Theorem 4.1 to a family of graphs obtained recursively.

Theorem 1.1: *Let $G = (E, V)$ be a locally finite weighted tree, where E is bounded, and let $\mathcal{V} : V \rightarrow \mathbb{R}$ be a potential. Then one has*

$$\eta(\mathcal{A}_G + \mathcal{V}) \in \{0, +\infty\} \text{ and } \eta(\Delta_G + \mathcal{V}) \in \{0, +\infty\}. \quad (1.5)$$

In particular, one obtains $\eta(G) \in \{0, +\infty\}$.

Moreover, in Sec. III D, we prove some generic results for random trees and their deterministic Schrödinger operators. We obtain

Proposition 1.3: Let $G = (E, V)$ be a random tree with independent and identically distributed (i.i.d.) offspring. Suppose that the offspring distribution has finite expectation. Then for almost all trees, the Schrödinger operators $\mathcal{A}_G + \mathcal{V}$ and $\Delta_G + \mathcal{V}$ are essentially self-adjoint on $C_c(G)$, for all potentials $\mathcal{V} : V \rightarrow \mathbb{R}$. In particular, almost surely, one gets $\eta(G) = 0$.

We refer to Sec. III D for definitions, a proof of this result, and also for Proposition 3.2, which treats the case of random offspring at a given generation.

We now present the structure of the paper. We start by proving, in Sec. II A, that the domains of the Laplacian and of the adjacency matrix are different for simple graphs of unbounded degree. Then,

in Sec. II B, we prove Proposition 1.1. Next, we present our main tool in Sec. II C. Subsequently, after giving a few definitions in Sec. III A, we discuss the setting of trees. We start by explaining in Sec. III B how to reduce in some cases the analysis of adjacency matrices to the one of Jacobi matrices. After that, in Sec. III C, we provide an example of tree G with “exponential growth” such that $\eta(G) = \infty$. Then, we prove Proposition 1.3 in Sec. III D. Next, in Sec. III E, we prove the first main result of the introduction, namely, Theorem 1.1 and generalize it in Sec. IV. Finally in the Appendix, we recall a general result of stability of deficiency indices, proposition A.1, and deduce a criterion for essential self-adjointness of Jacobi matrices, which possess unbounded diagonals.

Notation: The set of nonpositive integers is denoted by \mathbb{N} , note that $0 \in \mathbb{N}$. Given a set X and $Y \subseteq X$ let $\mathbf{1}_Y : X \rightarrow \{0, 1\}$ be the characteristic function of Y , namely, $\mathbf{1}_Y^{-1}\{1\} = Y$. We denote also by Y^c the complement set of Y in X .

II. GENERAL RESULTS

A. Comparison of domains

In view of Proposition A.1, it is tempting to try to prove that the adjacency matrix \mathcal{A}_G is self-adjoint by comparing it to the discrete Laplace operator Δ_G . (Remember that the latter is always essentially self-adjoint on $\mathcal{C}_c(G)$ by Proposition 1.1.) But, as a matter of fact, if the graph G is simple and has unbounded degree, we prove in this section that this is impossible.

Given a locally finite graph $G = (E, V)$ and a potential $\mathcal{V} : V \rightarrow \mathbb{R}$, we set $\mathcal{H}_G := \mathcal{A}_G + \mathcal{V}$. We first recall that the domain of the adjoint is given by

$$\mathcal{D}((\mathcal{H}_G)^*) = \left\{ f \in \ell^2(G), x \mapsto \left(\sum_{y \sim x} E(x, y) f(y) \right) + \mathcal{V}(x) f(x) \in \ell^2(G) \right\}.$$

Then, given $f \in \mathcal{D}((\mathcal{H}_G)^*)$, one has

$$((\mathcal{H}_G)^* f)(x) = \left(\sum_{y \sim x} E(x, y) f(y) \right) + \mathcal{V}(x) f(x), \text{ for all } x \in V.$$

We prove the result by

Proposition 2.1: Consider $G = (E, V)$ and suppose there is a sequence $(x_n)_{n \in \mathbb{N}}$ of points in V , so that

$$\lim_{n \rightarrow \infty} \sum_{y \sim x_n} E^2(y, x_n) = \infty \text{ and } \lim_{n \rightarrow \infty} \frac{\left(\sum_{y \sim x_n} E(y, x_n) \right)^2}{\sum_{y \sim x_n} E^2(y, x_n)} = \infty. \quad (2.1)$$

Then, $\mathcal{D}(\Delta_G) \neq \mathcal{D}(\mathcal{A}_G)$. In particular, the conclusion holds true when G is simple and has unbounded degree.

Proof: We suppose that $\mathcal{D}(\Delta_G) = \mathcal{D}(\mathcal{A}_G)$. Therefore, the uniform boundedness principle ensures that there are $a, b \geq 0$ such that

$$\|\Delta_G f\|^2 \leq a \|\mathcal{A}_G f\|^2 + b \|f\|^2, \text{ for all } f \in \mathcal{D}(\mathcal{A}_G). \quad (2.2)$$

We note now that one has that $\|\Delta_G(\mathbf{1}_{\{x_n\}})\|^2 = \sum_{y \sim x_n} E^2(y, x_n) + \left(\sum_{y \sim x_n} E(y, x_n) \right)^2$ and also that $\|\mathcal{A}_G(\mathbf{1}_{\{x_n\}})\|^2 = \sum_{y \sim x_n} E^2(y, x_n)$. Taking $f = \mathbf{1}_{\{x_n\}}$ in (2.2) leads to a contradiction.

Finally, when G is simple and has unbounded degree, consider a sequence $(x_n)_{n \in \mathbb{N}}$, so that $d_G(x_n)$ tends to infinity. \square

B. Essential self-adjointness of discrete Schrödinger operators

We prove some criteria of self-adjointness for Schrödinger operators.

Proof of Proposition 1.1: We start with the first point and mimic [Ref. 20, Theorem 1.3.1]. Using Proposition A.1, it is enough to suppose that \mathcal{V} is non-negative. Take $f \in \mathcal{D}((\Delta_G + \mathcal{V})^*)$ so that $(\Delta_G + \mathcal{V})^* f = -f$. Since $\Delta_G + \mathcal{V}$ is non-negative, it is enough to prove that $f = 0$. Notice that one has, for all $x \in V$,

$$\sum_{y \sim x} E(x, y) f(y) = \left(1 + \mathcal{V}(x) + \sum_{y \sim x} E(x, y)\right) f(x).$$

Therefore, given $x \in V$, there exists $y \sim x$ with $|f(y)| > |f(x)|$. This is in contradiction to the fact that $f \in \ell^2(G)$.

We turn to the second point. As there is no restriction on \mathcal{V} , it is enough to consider the case of $H := \mathcal{A}_G + \mathcal{V}$. We denote by $S_i := \{x \in V, \rho_V(x_0, x) = i\}$ the sphere of radius $i \in \mathbb{N}$ around $x_0 \in V$. For $n \in \mathbb{N}$, consider $a_n : \mathbb{N} \rightarrow [0, 1]$ with finite support and set $\chi_n := \sum_{i \in \mathbb{N}} a_n(i) \mathbf{1}_{S_i}$ and $\tilde{\chi}_n := 1 - \chi_n$. We see immediately that $\chi_n \mathcal{D}(H^*) \subset \mathcal{D}(H) \subset \mathcal{D}(H^*)$. Then, the commutator $[H^*, \chi_n]$, defined on $\mathcal{D}(H^*)$, is well defined (in the operator sense). Easily, it extends to a bounded operator, which we denote by $[H^*, \chi_n]_\circ$. We take $f \in \mathcal{D}(H^*)$ and will prove that it is also contained in $\mathcal{D}(H)$ by approximating it with $f_n := \chi_n f$. We have

$$\begin{aligned} \|f_m - f_n\| + \|H(f_m - f_n)\| &\leq \|(\chi_m - \chi_n)f\| + \|(\chi_m - \chi_n)H^* f\| \\ &\quad + \|[H^*, \chi_n]f\| + \|[H^*, \chi_m]f\|. \end{aligned} \tag{2.3}$$

We now choose a_n in order to make $(f_n)_{n \in \mathbb{N}}$ a Cauchy sequence with respect to the graph norm of H . Set

$$a_n(i) := \begin{cases} 1, & \text{for } i \leq n, \\ \min\{1, \max\{0, 1 - \frac{1}{n} \sum_{j=n+1}^i 1/b_j\}\}, & \text{for } i > n. \end{cases} \tag{2.4}$$

Notice that a_n has finite support, since $\sum_{j \in \mathbb{N}} 1/b_j = +\infty$. This gives that $\chi_n f$ and $\chi_n H^* f$ tend to f and $H^* f$, respectively. It remains to control the commutator in (2.3). By the Schur test and (2.4), we have

$$\begin{aligned} \|[H^*, \tilde{\chi}_n]_\circ\| &\leq \sup_{v \in V} \sum_{w \in V} |\langle \mathbf{1}_{\{v\}}, [H^*, \tilde{\chi}_n]_\circ \mathbf{1}_{\{w\}} \rangle| = \sup_{v \in V} \sum_{w \in V} |\langle \mathbf{1}_{\{v\}}, [\mathcal{A}_G, \tilde{\chi}_n] \mathbf{1}_{\{w\}} \rangle| \\ &= \sup_{v \in V} \sum_{w \in V} E(v, w) |\chi_n(w) - \chi_n(v)| = \sup_{v \in V} \sum_{w \in V, \rho_V(w, v)=1} E(v, w) |\chi_n(w) - \chi_n(v)| \leq \frac{1}{n}. \end{aligned}$$

Returning to (2.3), this implies that f_n is a Cauchy sequence in $\mathcal{D}(H)$. Let g be its limit. Since H is closed, $g \in \mathcal{D}(H)$ and $g = f$.

We turn to (3) and (4). Taking in account the contribution of the potential, we essentially rewrite [Ref. 11, Proposition 1.1]. Take $f \in C_c(G)$. For d_G bounded let $\mathcal{M}(x) := E(x)$ and for E bounded let $\mathcal{M}(x) := d_G(x)$. Let \mathcal{M} be the operator of multiplication by $\mathcal{M}(\cdot)$, too. We denote all constants, which are independent from f , by the same letter C . We have

$$\begin{aligned} \|(\mathcal{A}_G + \mathcal{V})f\|^2 &\leq 2 \sum_x \left| \sum_{y \sim x} E(x, y) f(y) \right|^2 + 2\|\mathcal{V}f\|^2 \leq 2 \sum_x d_G(x) E^2(x) \sum_{y \sim x} |f(y)|^2 + 2\|\mathcal{V}f\|^2 \\ &\leq 2 \sum_x d_G(x) \max_{y \sim x} (d_G(y)) E^2(x) |f(x)|^2 + 2\|\mathcal{V}f\|^2 \\ &\leq 2 \sum_x E^2(x) d_G(x) (C + d_G(x)) |f(x)|^2 + 2\|\mathcal{V}f\|^2 \leq C \|\mathcal{M}f\|^2. \end{aligned}$$

Moreover, noticing that the potential \mathcal{V} commutes with \mathcal{M} , we get

$$\begin{aligned} |\langle f, [\mathcal{A}_G, \mathcal{M}]f \rangle| &= \left| \sum_x \overline{f(x)} \sum_{y \sim x} E(x, y) (\mathcal{M}(y) - \mathcal{M}(x)) f(y) \right| \\ &\leq \sum_x \sum_{y \sim x} C |E^{1/2}(x) f(x)| |E^{1/2}(y) f(y)| \\ &\leq c \sum_x d_G(x) |E^{1/2}(x) f(x)|^2 \leq C \|\mathcal{M}^{1/2} f\|^2. \end{aligned}$$

Then, using [Ref. 19, Theorem 10.36], the result follows.

We deal now with the fifth point. As a potential is essentially self-adjoint on $\mathcal{C}_c(G)$, thanks to Wüst's Theorem, e.g., [Ref. 19, Theorem 10.14], it is enough to prove that there is $b \geq 0$ so that,

$$\|\mathcal{A}_G f\|^2 \leq \|\mathcal{V} f\|^2 + b \|f\|^2, \text{ for all } f \in \mathcal{C}_c(G). \tag{2.5}$$

As $x \mapsto \mathcal{V}(x) \mathbf{1}_K(x)$ is bounded, it is enough to prove (2.5) with $b = 0$ and under the stronger hypothesis: $\sum_{y \sim x} E^2(x, y) d_G(y) \leq \mathcal{V}^2(x)$ for all $x \in V$. The statement is now obvious as, for all $f \in \mathcal{C}_c(G)$, one has

$$\|\mathcal{A}_G f\|^2 = \sum_{x \in V} \sum_{y \sim x} |E(x, y) f(y)|^2 \leq \sum_{x \in V} \sum_{y \sim x} d_G(x) E^2(x, y) |f(y)|^2 = \sum_{x \in V} \sum_{y \sim x} d_G(y) E^2(x, y) |f(x)|^2.$$

Finally, by using the last inequality and by taking into account the diagonal part of the Laplacian, one has, for all $f \in \mathcal{C}_c(G)$,

$$\|\Delta_G f\|^2 \leq \sum_{x \in V} \left(\sum_{y \sim x} d_G(y) E^2(x, y) + E^2(x, y) \right) |f(x)|^2.$$

Wüst's Theorem gives the last point. □

Remark 2.1: Given $a \in [0, 1)$, note that if one strengthens the assumption in the fourth point to

$$\sum_{y \sim x} E^2(x, y) d_G(y) \leq a \mathcal{V}^2(x), \text{ for all } x \notin K$$

the previous proof and the Kato-Rellich theorem (or more generally Proposition A.1) ensures $\mathcal{D}(\mathcal{A}_G + \mathcal{V}) = \mathcal{D}(V)$, too. In the same spirit, if one supposes that $\sum_{y \sim x} E^2(x, y) (1 + d_G(y)) \leq a \mathcal{V}^2(x)$ for all $x \notin K$ in the fifth point, one gets also $\mathcal{D}(\Delta_G + \mathcal{V}) = \mathcal{D}(V)$.

C. Bounded perturbations of graphs and deficiency indices

In this section, we compute the deficiency indices, in the case one adds up to a given number of edges per vertex to a countable union of graphs. We slightly improve the surgery Lemma of Ref. 11.

Lemma 2.1: Given a sequence of graphs $G_n = (E_n, V_n)$, for $n \in \mathbb{N}$, let $G^\circ := (E^\circ, V^\circ) := \bigcup_{n \in \mathbb{N}} G_n$ be the disjoint union of $\{G_n \mid n \in \mathbb{N}\}$. Choose $\tilde{E} : V^\circ \times V^\circ \rightarrow [0, \infty)$, so that \tilde{E} is symmetric, with support away from the diagonal. Set $G := (E, V)$ with $V = V^\circ$ and $E := E^\circ + \tilde{E}$. Suppose that

$$\sup_{x \in V} \sum_{y \in V} \tilde{d}_G(y) \tilde{E}^2(x, y) < \infty, \tag{2.6}$$

where $\tilde{d}_G(x) := |\{y \in V, \tilde{E}(x, y) \neq 0\}|$. Consider a potential $\mathcal{V} : V \rightarrow \mathbb{R}$. Set $\mathcal{H}_G := \mathcal{A}_G + \mathcal{V}$ and $\mathcal{H}_{G_n} := \mathcal{A}_{G_n} + \mathcal{V}|_{G_n}$. Then, one obtains

$$\eta(\mathcal{H}_G) = \sum_{n \in \mathbb{N}} \eta(\mathcal{H}_{G_n}).$$

In particular, $\eta(G) = \sum_{n \in \mathbb{N}} \eta(G_n)$.

Proof: Take $f \in \mathcal{C}_c(G) = \mathcal{C}_c(G^\circ)$. Set $\mathcal{H}_{G^\circ} := \bigoplus_{n \in \mathbb{N}} \mathcal{H}_{G_n}$. Notice that

$$\begin{aligned} \|(\mathcal{H}_G - \mathcal{H}_{G^\circ})f\|^2 &= \sum_{x \in V} \left| \sum_{y \in V} \tilde{E}(x, y) f(y) \right|^2 \leq \sum_{x \in V} \sum_{y \in V} \tilde{d}_G(x) \tilde{E}^2(x, y) |f(y)|^2 \\ &= \sum_{x \in V} \left(\sum_{y \in V} \tilde{d}_G(y) \tilde{E}^2(x, y) \right) |f(x)|^2. \end{aligned}$$

We infer, there is a finite M , so that $\|(\mathcal{H}_G - \mathcal{H}_{G^\circ})f\| \leq M\|f\|$, for all $f \in \mathcal{C}_c(G) = \mathcal{C}_c(G^\circ)$. Then, the closure of $(\mathcal{H}_G - \mathcal{H}_{G^\circ})$ is a bounded operator and Proposition A.1 can be applied.

Alternatively, one can conclude using an argument of Ref. 11. Since the closure of $(\mathcal{H}_G - \mathcal{H}_{G^\circ})$ is a bounded operator, the graph norms of \mathcal{H}_G and of \mathcal{H}_{G° are equivalent when restricted to $\mathcal{C}_c(G)$. By taking the closure, we infer $\mathcal{D}(\mathcal{H}_G) = \mathcal{D}(\mathcal{H}_{G^\circ})$. Moreover, using again the boundedness of the difference and the definition of the domain of the adjoints of \mathcal{H}_G and of \mathcal{H}_{G° , one gets directly $\mathcal{D}((\mathcal{H}_G)^*) = \mathcal{D}((\mathcal{H}_{G^\circ})^*)$. Finally, since the deficiency indices $\eta_\pm(\mathcal{H}_G)$ of \mathcal{H}_G are equal (and of \mathcal{H}_{G° , resp.), (A1) gives that $\eta(\mathcal{H}_G) = \eta(\mathcal{H}_{G^\circ})$. \square

Example 2.1: Given a locally finite graph $G := (E, V)$ with bounded weights E and a set of vertices $X \subseteq V$, such that $\sup d_G(X) < \infty$, then the induced graph $G' = G[V \setminus X]$, obtained by removing the vertices in X , has deficiency index $\eta(G') = \eta(G)$.

D. Tensor products and deficiency indices

For the sake of completeness and motivated by Remark 2.2 (see below), we discuss shortly the tensor product of graphs regarding the computation of deficiency indices. We recall that given two graphs $G_i = (E_i, V_i)$, $i = 1, 2$, one defines the tensor product $G := (E, V)$ of G_1 with G_2 by setting $V := V_1 \times V_2$ and $E((x_1, x_2), (y_1, y_2)) := E(x_1, y_1) \cdot E(x_2, y_2)$. One sees that $\mathcal{A}_{G_1 \otimes G_2} = \mathcal{A}_{G_1} \otimes \mathcal{A}_{G_2}$. We turn to the question of deficiency indices. It is well-known that $\eta(G_1 \otimes G_2) = 0$ if $\eta(G_1) = \eta(G_2) = 0$, e.g., [Ref. 19, Theorem 7.33]. One has also that $\eta(G_1 \otimes G_2) = \infty$, when $\eta(G_1) = \infty$ and $\eta(G_2) > 0$. In fact, in the general case, one obtains easily a lower bound on the deficiency indices.

Lemma 2.2: Given two symmetric operators S, T acting on the Hilbert spaces \mathcal{H} and \mathcal{K} , respectively. Let $\eta = \max_{i \in \{\pm\}} (\eta_i(S) \cdot \eta_i(T))$, with the convention $0 \cdot \infty = 0$. Then, $\eta_\pm(S \otimes T) \geq \eta$.

Proof: We recall that, given a symmetric operator H , $z \mapsto \dim \ker(H^* - z)$ is constant on the upper and lower open half-planes of \mathbb{C} . Therefore, it is enough to give a lower bound for $\dim \ker(S^* \otimes T^* - z^2)$, for $z = e^{i\pi(1/2 \pm 1/4)}$. Take $f \in \mathcal{D}(S^*)$ and $g \in \mathcal{D}(T^*)$, so that $S^*f = zf$ and $T^*g = zg$. One has

$$S^* \otimes T^*(f \otimes g) - z^2 f \otimes g = (S^*f - zf) \otimes T^*g + zf \otimes (T^*g - zg) = 0.$$

This concludes the proof. \square

It is, however, more important to obtain the exact value of the deficiency indices. We recall the following elementary fact:

Lemma 2.3: Let G be a locally finite graph and K be a finite graph. Then, one deduces

$$\eta(G \otimes K) = \eta(G) \cdot \dim(\text{Im}(\mathcal{A}_K)).$$

Proof: As \mathcal{A}_K is self-adjoint in a finite dimensional Hilbert space, we can decompose it with the help of its eigenspaces. We have $\mathcal{A}_K = \bigoplus_i \lambda_i \mathbf{1}_{E_i}$, where E_i is the eigenspace associated to the eigenvalue λ_i . Note that $(\mathcal{A}_{G \otimes K})^* = \bigoplus_i \lambda_i (\mathcal{A}_G)^* \otimes \mathbf{1}_{E_i}$. To conclude, we notice that $\dim(\ker((\mathcal{A}_G)^* \otimes \mathbf{1}_{E_i} + i)) = \dim(\ker((\mathcal{A}_G)^* + i)) \times \dim \mathbf{1}_{E_i}$. \square

We now come back to the conjecture mentioned in the introduction following (1.4).

Remark 2.2: *The complete graph $K_2 = (E_2, V_2)$ is defined by $V_2 := \{0, 1\}$ and $E_2(0, 1) = 1$. Note that \mathcal{A}_{K_2} is injective. Its spectrum is $\{-1, 1\}$. Given a locally finite graph G , the previous lemma states that $\eta(G \otimes K_2) = 2\eta(G)$. Moreover, note that $G \otimes K_2$ is bipartite. Therefore if (1.4) is true for all bipartite simple graphs, then it is true for all simple graphs.*

III. THE CASE OF A TREE

A. Some definitions related to trees

It is convenient to choose a root in the tree. Due to its structure, one can take any point of V . We denote it by ϵ .

We define inductively the *spheres* S_n by $S_{-1} = \emptyset$, $S_0 := \{\epsilon\}$, and $S_{n+1} := \mathcal{N}_G(S_n) \setminus S_{n-1}$. Given $n \in \mathbb{N}$, $x \in S_n$, and $y \in \mathcal{N}_G(x)$, one sees that $y \in S_{n-1} \cup S_{n+1}$. We write $x \rightsquigarrow y$ and say that x is a *son* of y , if $y \in S_{n-1}$, while we write $x \prec y$ and say that x is a *father* of y , if $y \in S_{n+1}$. Notice that ϵ has no father. Given $x \neq \epsilon$, note that there is a unique $y \in V$ with $x \rightsquigarrow y$, i.e., everyone apart from ϵ has one and only one father. We denote the father of x by \overleftarrow{x} . Given $x \in S_n$, we set $\ell(x) := n$, the *length* of x . The *offspring* of an element x is given by $\text{off}(x) := |\{y \in \mathcal{N}_G(x), y \rightsquigarrow x\}|$, i.e., it is the number of sons of x . When $\ell(x) \geq 1$, note that $\text{off}(x) = d_G(x) - 1$.

B. Diagonalization in the case of an offspring depending on the generation

In this section, we define a certain family of trees. Then, we explain how to explicitly diagonalize the adjacency matrices on them. We start with a definition.

Definition 3.1: A simple tree $G = (E, V)$ with offspring sequence $(b_n)_{n \in \mathbb{N}}$ is a simple tree with a root such that $b_n = \text{off}(x)$, for each $x \in S_n$ and $n \in \mathbb{N}$.

In Proposition 3.2, we consider a family of trees with random offspring per individual and generation. At the moment, we focus on the deterministic case and give a concrete example,

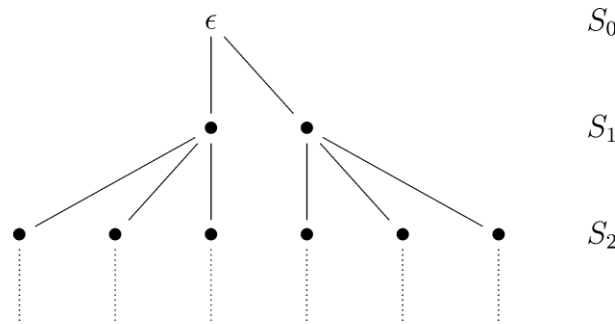

Example of a tree with $b_0 = 2$ and $b_1 = 3$.

Now we adapt the decomposition of a tree given in Ref. 1, see also Ref. 10, in order to write the adjacency matrix as a direct sum of Jacobi matrices. We consider the tree $G = (E, V)$ with offspring sequence $(b_n)_{n \in \mathbb{N}}$. We define

$$(Uf)(x) := \mathbf{1}_{\{\cup_{n \geq 1} S_n\}}(x) \frac{1}{\sqrt{b_{\ell(\overleftarrow{x})}}} f(\overleftarrow{x}), \text{ for } f \in \ell^2(G).$$

Easily, one get $\|Uf\| = \|f\|$, for all $f \in \ell^2(G)$. Moreover, it is a completely non-unitary isometry, i.e., it is an isometry, such that the strong limit $\text{s-lim}_{k \rightarrow \infty} (U^*)^k = 0$. The adjoint U^* of U is given by

$$(U^*f)(x) := \frac{1}{\sqrt{b_{\ell(x)}}} \sum_{y \rightsquigarrow x} f(y), \text{ for } f \in \ell^2(G).$$

Note that one has

$$(\mathcal{A}_G f)(x) = \sqrt{b_{\ell(\bar{x})}}(Uf)(x) + \sqrt{b_{\ell(x)}}(U^* f)(x), \text{ for } f \in \mathcal{C}_c(G).$$

Supposing now that $b_n \geq 1$ for all $n \in \mathbb{N}$, we construct invariant subspaces for \mathcal{A}_G . We start by noticing that $\dim \ell^2(S_n) = \prod_{i=0, \dots, n-1} b_i$, for $n \geq 1$ and $\dim \ell^2(S_0) = 1$. Therefore, as U is an isometry, $U\ell^2(S_n) = \ell^2(S_{n+1})$ if and only if $b_n = 1$. Set $\mathbb{Q}_{0,0} := \ell^2(S_0)$ and $\mathbb{Q}_{0,k} := U^k \mathbb{Q}_{0,0}$, for all $k \in \mathbb{N}$. Note that $\dim \mathbb{Q}_{0,k} = \dim \ell^2(S_0) = 1$, for all $k \in \mathbb{N}$. Moreover, given $f \in \ell^2(S_k)$, one has $f \in \mathbb{Q}_{0,k}$ if and only if f is constant on S_k . We define recursively $\mathbb{Q}_{n,n+k}$ for $k, n \in \mathbb{N}$. Given $n \in \mathbb{N}$, suppose that $\mathbb{Q}_{n,n+k}$ is constructed for all $k \in \mathbb{N}$, and set

- $\mathbb{Q}_{n+1,n+1}$ as the orthogonal complement of $\bigoplus_{i=0, \dots, n} \mathbb{Q}_{i,n+1}$ in $\ell^2(S_{n+1})$,
- $\mathbb{Q}_{n+1,n+k+1} := U^k \mathbb{Q}_{n+1,n+1}$, for all $k \in \mathbb{N} \setminus \{0\}$.

We sum-up the construction in the following diagram:

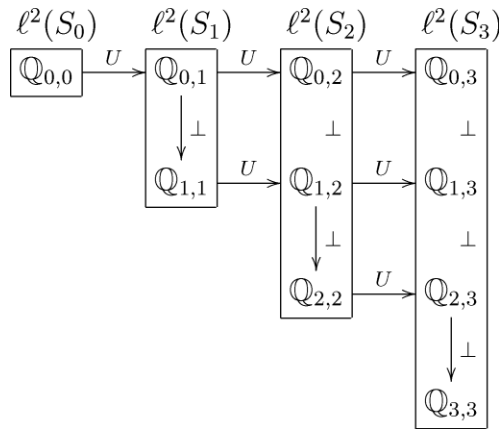

We point out that $\dim \mathbb{Q}_{n+1,n+1} = \dim \mathbb{Q}_{n+1,n+k+1}$, for all $k \in \mathbb{N}$ and stress that it is 0 if and only if $b_n = 1$. Notice that $U^* \mathbb{Q}_{n,n} = 0$, for all $n \in \mathbb{N}$. Set finally $\mathbb{M}_n := \bigoplus_{k \in \mathbb{N}} \mathbb{Q}_{n,n+k}$ and note that $\ell^2(G) = \bigoplus_{n \in \mathbb{N}} \mathbb{M}_n$. Moreover, one has that canonically $\mathbb{M}_n \simeq \ell^2(\mathbb{N}; \mathbb{Q}_{n,n}) \simeq \ell^2(\mathbb{N}) \otimes \mathbb{Q}_{n,n}$. In this representation, the restriction \mathcal{A}_n of \mathcal{A}_G to the space \mathbb{M}_n is given by the following tensor product of Jacobi matrices,

$$\mathcal{A}_n \simeq \begin{pmatrix} 0 & \sqrt{b_n} & 0 & 0 & \dots \\ \sqrt{b_n} & 0 & \sqrt{b_{n+1}} & 0 & \ddots \\ 0 & \sqrt{b_{n+1}} & 0 & \sqrt{b_{n+2}} & \ddots \\ \vdots & \ddots & \ddots & \ddots & \ddots \end{pmatrix} \otimes \mathbf{1}_{\mathbb{Q}_{n,n}}.$$

Now \mathcal{A}_G is given as the direct sum $\bigoplus_{n \in \mathbb{N}} \mathcal{A}_n$ in $\bigoplus_{n \in \mathbb{N}} \mathbb{M}_n$. In particular, $\eta(G) = \sum_{n \in \mathbb{N}} \eta(\mathcal{A}_n)$. Note that if $b_n = 1$, for all $n \in \mathbb{N}$, we recover the case of the adjacency matrix of the simple graph \mathbb{N} .

We now turn to the case of $b_n := \lfloor n^\alpha \rfloor$, for some $\alpha > 0$.

Proof of Proposition 1.2: The sum $\sum_{n \in \mathbb{N}} 1/\sqrt{b_n}$ is finite if and only if $\alpha > 2$. Then [Ref. 3, page 504] yields that $\mathcal{A}_n = (\mathcal{A}_n)^*$ for $\alpha \in [0, 2]$ and $n \in \mathbb{N}$. One infers that $\eta(G) = 0$. Now, easily one sees that $b_{i-1} b_{i+1} \leq b_i^2$, for $i \geq 1$. Thus, [Ref. 3, page 507] gives that $\eta(\mathcal{A}_n) = \dim(\mathbb{Q}_{n,n})$. This completes the proof. \square

C. Trees with exponential growth and non-essential self-adjointness

In Sec. II B, we focused on trees with given offspring per individual for each generation. We now replace this hypothesis by a control on the maximum and on the minimum of the offspring of individuals for each generation. We turn to the result, see also Refs. 16 and 18.

Proposition 3.1: Let $G = (E, V)$ be a locally finite simple tree, endowed with an origin. Supposing

$$n \mapsto \frac{\max_{x \in S_{n-1}} \text{off}(x)}{\min_{x \in S_n} \text{off}(x)} \in \ell^1(\mathbb{N}), \tag{3.1}$$

one has that $\eta(G) = \infty$.

Condition (3.1) can be interpreted as an “exponential growth.”

Proof: We construct $f \in \ell^2(G) \setminus \{0\}$, so that $(\mathcal{A}_G)^* f = i f$ and

$$f(x) = f(y), \text{ if } \overleftarrow{x} = \overleftarrow{y}, \quad (x, y \in V \setminus \{\epsilon\})$$

i.e., for all $x \in V$, f is constant on $\text{off}(x)$. We denote the constant value by $f(\sim > x)$. With this notation, we have

$$\text{off}(x) f(\sim > x) + f(\overleftarrow{x}) = i f(x), \tag{3.2}$$

for all $x \in S_n$, with $n \geq 1$. We denote by $\|f\|_{S_n}$ the ℓ^2 -norm of f restricted to S_n . Then we have

$$\begin{aligned} \|f\|_{S_{n+1}}^2 &= \sum_{x \in S_{n-1}} \sum_{y \sim > x} \sum_{z \sim > y} |f(z)|^2 = \sum_{x \in S_{n-1}} \sum_{y \sim > x} \sum_{z \sim > y} |f(\sim > y)|^2, \\ &\leq \sum_{x \in S_{n-1}} \sum_{y \sim > x} \sum_{z \sim > y} \frac{2}{\text{off}^2(y)} (|f(y)|^2 + |f(x)|^2), \text{ by (3.2)} \\ &\leq 2 \frac{\max_{x \in S_{n-1}} \text{off}(x)}{\min_{x \in S_n} \text{off}(x)} \|f\|_{S_{n-1}}^2 + \frac{2}{\min_{x \in S_n} \text{off}(x)} \|f\|_{S_n}^2. \end{aligned}$$

By induction, one sees that $\sup_{n \in \mathbb{N}} \|f\|_{S_n}^2$ is finite. Finally using (3.1), we derive that $f \in \ell^2(G)$. Theorem 1.1 concludes that the deficiency indices are infinite. \square

D. Discrete Schrödinger operators and random trees

In this section, we discuss certain random trees. Before dealing with random trees in the sense of Definition 3.2, we start with trees with random offspring sequence, see Definition 3.1.

We recall some well-known notions from probability theory. The *left shift* on $\mathbb{N}^{\mathbb{N}}$ is defined by $\tau : \mathbb{N}^{\mathbb{N}} \rightarrow \mathbb{N}^{\mathbb{N}}, \tau((x_n)_{n \in \mathbb{N}}) := (x_{n+1})_{n \in \mathbb{N}}$. We assign the discrete topology to \mathbb{N} and the product topology to $\mathbb{N}^{\mathbb{N}}$. Therefore, τ is continuous. An \mathbb{N} -valued stochastic process $X := (X_n)_{n \in \mathbb{N}}$, is called *ergodic*, if for all Borel-measurable $A \subseteq \mathbb{N}^{\mathbb{N}}$, one has

$$P(X \in A \text{ and } \tau(X) \notin A) + P(X \notin A \text{ and } \tau(X) \in A) = 0 \Rightarrow P(X \in A) \in \{0, 1\}$$

and *stationary*, if

$$P(X \in A) = P(\tau(X) \in A)$$

for all Borel-measurable $A \subseteq \mathbb{N}^{\mathbb{N}}$. For example, if $X_n, n \in \mathbb{N}$, are i.i.d. random variables then the process $(X_n)_{n \in \mathbb{N}}$ is stationary and ergodic.

Proposition 3.2: Let $G = (E, V)$ be a tree with offspring sequence $(b_n)_{n \in \mathbb{N}}$, where $(b_n)_{n \in \mathbb{N}}$ is a stationary and ergodic stochastic process. Then for almost every G , the Schrödinger operators $\mathcal{A}_G + \mathcal{V}$ and $\Delta_G + \mathcal{V}$ are essentially self-adjoint on $C_c(G)$, for all $\mathcal{V} : V \rightarrow \mathbb{R}$.

Proof: Take $m \in \mathbb{N}$, so that $P(b_0 = m) > 0$. Since $(b_n)_{n \in \mathbb{N}}$ is a stationary and ergodic \mathbb{N} -valued stochastic process, there is, almost surely, a subsequence $(b_{n_k})_{k \in \mathbb{N}}$ with $b_{n_k} = m$ for all $k \in \mathbb{N}$. Consider now the forest of finite trees obtained by removing all edges between S_{n_k} and S_{n_k+1} , for all $n \in \mathbb{N}$. Note that, for each element of S_{n_k+1} , there is at most one edge connecting it to S_{n_k} . The Schrödinger operators, restricted to the finite trees, are all essentially self-adjoint. Lemma 2.1 gives the result. \square

Next we consider random trees. Denote by $W := \bigcup_{n \in \mathbb{N}} (\mathbb{N}^*)^n$ the set of all finite words over the alphabet $\mathbb{N}^* := \mathbb{N} \setminus \{0\}$. The length of a word $w = (w_1, \dots, w_n) \in W$ is $\ell(w) := n$.

Definition 3.2: Let $(X_w)_{w \in W}$ be a family of i.i.d. random variables with values in \mathbb{N} . We construct a graph $G = (E, V)$ as follows:

$$V := \{(w_1, \dots, w_n) \in W \mid w_{m+1} \leq X_{(w_1, \dots, w_m)} \text{ for all } m \in \mathbb{N}, m < n\} \text{ and}$$

$$E(v, w) := \begin{cases} 1 & \text{if } \{\ell(v), \ell(w)\} = \{n, n+1\} \text{ and } (v_0, \dots, v_n) = (w_0, \dots, w_n) \\ 0 & \text{otherwise,} \end{cases}$$

for $v = (v_1, \dots, v_{\ell(v)})$, $w = (w_1, \dots, w_{\ell(w)}) \in V$. We call G random tree with i.i.d. offspring. The law of X_ϵ is called offspring distribution of G .

Note that a random tree is a tree with the empty word ϵ as root. Words of length n correspond to S_n , the n -sphere. Hence, the notation ℓ of the length is consistent with the one given in Sec. III A.

Proposition 3.3: Let $G = (E, V)$ be a random tree with i.i.d. offspring, such that its offspring distribution has finite expectation. Then almost surely there are $M \geq 1$ and a family $(G_i)_{i \in \mathbb{N}}$ of disjoint finite subtrees $G_i := (E_i, V_i)$ of G , so that $V = \bigcup_{i \in \mathbb{N}} V_i$

$$\sup_{i \in \mathbb{N}} \max_{x \in \max(V_i)} \text{off}(x) \leq M, \tag{3.3}$$

where $\max(V_i) := \{x \in V_i, (y \rightsquigarrow x \text{ in } G) \Rightarrow y \notin V_i\}$, for all $i \in \mathbb{N}$.

Proof: Since the offspring distribution has finite expectation, there is $M \in \mathbb{N}$ such that

$$\sum_{m > M} m P(X_\epsilon = m) < 1. \tag{3.4}$$

Let $\tilde{G} := G \setminus L$ be the forest one gets by deleting all the edges in

$$L := \{(v, w) \in V \times V \mid \ell(v) < \ell(w), \text{off}_G(v) \leq M\}$$

from G . Each connected component in \tilde{G} is a random tree with independent offspring. Denote by $\hat{G} = (\hat{E}, \hat{V})$ a connected component of \tilde{G} . The expected number of sons in \hat{G} is given by the lhs in (3.4). It is well known that such family trees almost surely get extinct, see e.g., Ref. 14, Theorem 3.11]. Therefore all the connected components of \tilde{G} are almost surely finite. We present a proof here.

The tree \hat{G} has a root $\hat{w}_0 \in \hat{V}$ with $\ell(\hat{w}_0) = \min\{\ell(\hat{w}) \mid \hat{w} \in \hat{V}\}$. We define the n -sphere of \hat{G} to be $\hat{S}_n := \{\hat{w} \in \hat{V} \mid \ell(\hat{w}) = n + \ell(\hat{w}_0)\}$ and denote by $\hat{X}_{\hat{w}} := \text{off}_{\hat{G}}(\hat{w})$ the number of sons of $\hat{w} \in \hat{V}$ in \hat{G} . The random variable $\hat{Y}_n := |\hat{S}_n|$ fulfills $\hat{Y}_n = \sum_{\hat{w} \in \hat{S}_{n-1}} \hat{X}_{\hat{w}}$ and is hence measurable with respect to the σ -algebra $\hat{\mathcal{F}}_n := \sigma(\hat{X}_{\hat{w}} \mid \hat{w} \in \bigcup_{j=0}^{n-1} \hat{S}_j)$. Therefore the stochastic process $(\hat{Y}_n)_{n \in \mathbb{N}}$ is adapted to the filtration $(\hat{\mathcal{F}}_n)_{n \in \mathbb{N}}$. With (3.4), for all $n \in \mathbb{N}$ we have

$$\mathbb{E}[\hat{Y}_{n+1} \mid \hat{\mathcal{F}}_n] = \sum_{\hat{w} \in \hat{S}_n} \mathbb{E}[\hat{X}_{\hat{w}} \mid \hat{\mathcal{F}}_n] = \sum_{\hat{w} \in \hat{S}_n} \mathbb{E}[\hat{X}_{\hat{w}}] = \hat{Y}_n \mathbb{E}[\hat{X}_{\hat{w}_0}] \leq \hat{Y}_n. \tag{3.5}$$

Hence, the process $(\hat{Y}_n)_{n \in \mathbb{N}}$ is a supermartingale. Since $\hat{Y}_n \geq 0$, the martingale convergence theorem guarantees that \hat{Y}_n converges almost surely. We denote its limit by \hat{Y} . With (3.5) we entail

$$0 \leq \mathbb{E}[\hat{Y}_n] = \mathbb{E}[\mathbb{E}[\hat{Y}_n \mid \hat{\mathcal{F}}_{n-1}]] = \mathbb{E}[\hat{Y}_{n-1} \mathbb{E}[\hat{X}_{\hat{w}_0}]] = \mathbb{E}[\hat{Y}_{n-1}] \mathbb{E}[\hat{X}_{\hat{w}_0}] = (\mathbb{E}[\hat{X}_{\hat{w}_0}])^n.$$

In view of (3.4), Fatou’s Lemma ensures that $\mathbb{E}[\hat{Y}] = 0$ and therefore that $\hat{Y} = 0$ almost surely. Finally, since \hat{Y} assumes only integer values, for almost every realization of $(\hat{Y}_n)_{n \in \mathbb{N}}$ there exists $N \in \mathbb{N}$ with $\hat{Y}_n = 0$ for all $n \geq N$. \square

It remains to prove the announced result.

Proof of Proposition 1.3: Almost surely, Proposition 3.3 gives a forest of finite trees $G_i = (E_i, V_i)$. On each of them, the restriction of the Schrödinger operator is essentially self-adjoint, as $\ell^2(G_i)$ is finite dimensional. Moreover, as $\bigcup_{i \in \mathbb{N}} V_i = V$ and (3.3) holds true, the hypothesis of Lemma 2.1 are satisfied and the result follows. \square

E. The possible indices

We now prove our main result in the context of trees and improve it in Sec. IV. This is a proof by contradiction.

We start with some notations about subgraphs. The connected component $C_G(x)$ of $x \in V$ is the graph $C_G(x) := (E_x, V_x)$ with $V_x := \{y \in V, \text{ there is an } x\text{-}y\text{-path}\}$ and $E_x := E|_{V_x \times V_x}$. A graph $G' := (E', V')$ is called a *subgraph* of G , if $V' \subseteq V$ and $E'(x, y) \in \{0, E(x, y)\}$, for all $x, y \in V'$. The subgraph $G[V'] := (E|_{V' \times V'}, V')$ is called the *induced graph* of G by $V' \subseteq V$. Given a set $S \subseteq V \times V$, we denote $S_{\text{sym}} := \{(x, y), (y, x) \mid (x, y) \in S\}$ and by S_{sym}^c its complement in $V \times V$. The graph $G \setminus S := (E|_{S_{\text{sym}}^c}, V)$ is obtained by deleting the edges in S_{sym} from G .

Proof of Theorem 1.1: Suppose that $G = (E, V)$ is a locally finite tree with bounded weights. In view of (1.3), it is enough to consider a discrete Schrödinger operator \mathcal{H}_G of the form $\mathcal{A}_G + \mathcal{V}$ for some potential $\mathcal{V} : V \rightarrow \mathbb{R}$. Suppose that \mathcal{H}_G has finite and (strictly) positive deficiency index $\eta(\mathcal{H}_G) > 0$. Given a subgraph $G' = (E', V')$ of G , we denote by $\mathcal{H}_{G'}$ the Schrödinger operator given by $\mathcal{A}_{G'} + \mathcal{V}|_{V'}$.

We construct inductively a sequence $(v_k)_{k \in \mathbb{N}}$ of points of V , so that $v_k \sim v_{k+1}$ for all $k \in \mathbb{N}$. Along the way we also define a sequence of subgraphs $(G_k)_{k \in \mathbb{N}}$ of G , such that $G_k := (E_k, V_k)$ is a tree, satisfying $v_k \in V_k$ and $\eta(\mathcal{H}_{G_k}) \geq \eta(\mathcal{H}_{G_{k+1}}) > 0$. Start with $G_0 := G$ and some $v_0 \in V$. For each $k \in \mathbb{N}$ we first remove the edges connected to v_k and obtain $G'_k := G_k \setminus (\{v_k\} \times \mathcal{N}_{G_k}(v_k))$. Using Lemma 2.1 and the fact that G_k is a tree, we find

$$0 < \eta(\mathcal{H}_{G_k}) = \eta(\mathcal{H}_{G'_k}) = \sum_{w \in \mathcal{N}_{G'_k}(v_k)} \eta(\mathcal{H}_{C_{G'_k}(w)}).$$

Therefore there exists $w \in \mathcal{N}_{G'_k}(v_k)$ with $\eta(\mathcal{H}_{C_{G'_k}(w)}) > 0$. Set $v_{k+1} := w$ and $G_{k+1} := C_{G'_k}(w)$. As announced the graph G_{k+1} is a tree.

Since $k \mapsto \eta(\mathcal{H}_{G_k})$ is decreasing, positive, and has integer values, there is $K \in \mathbb{N}$ so that $\eta(\mathcal{H}_{G_k})$ is constant for all $k \geq K$. Now consider $\tilde{G}_k := G_k[V_k \setminus V_{k+1}]$.

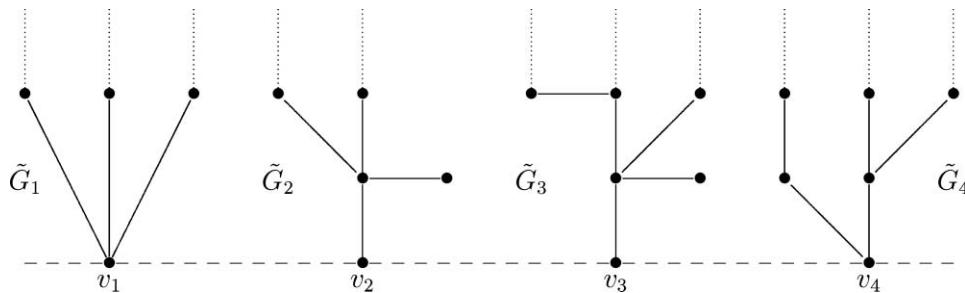

The dashed line at the bottom shows the constructed path $(v_k)_{k \in \mathbb{N}}$. The graphs \tilde{G}_k can extend infinitely, as indicated with the dots. For all $k \in \mathbb{N}$ the graph G_k is the union of all $\tilde{G}_{k'}$ with $k' \geq k$ plus the dashed bottom line starting at v_k .

Again by Lemma 2.1, we infer

$$\eta(\mathcal{H}_{\tilde{G}_k}) = \eta(\mathcal{H}_{G_k}) - \eta(\mathcal{H}_{G_{k+1}}) = 0, \text{ for } k \geq K.$$

By one more application of Lemma 2.1, we obtain

$$0 < \eta(\mathcal{H}_{G_K}) = \sum_{k=K}^{\infty} \eta(\mathcal{H}_{\tilde{G}_k}) = 0.$$

This is a contradiction. □

IV. RECURSIVE GRAPHS

In this section, we generalize the previous approach to graphs which satisfy a certain recursive property. We shall use the notation related to subgraphs, which were introduced in Sec. III E. To simplify notation, given a potential $\mathcal{V} : V \rightarrow \mathbb{R}$ and the Schrödinger operator $\mathcal{H}_G := \mathcal{A}_G + \mathcal{V}$ acting on $G = (E, V)$, we shall write $\eta_{\mathcal{H}}(G) := \eta(\mathcal{H}_G)$. As above, if G' is a subgraph of G obtained by removing edges, we denote by $\mathcal{H}_{G'}$ the Schrödinger operator $\mathcal{A}_{G'} + \mathcal{V}$.

Definition 4.1: Let $G = (E, V)$ be a locally finite graph. Given $M > 0$ and $\mathcal{V} : V \rightarrow \mathbb{R}$, we say that G has the property $\mathcal{R}(M, \mathcal{V})$, if

- either $\eta_{\mathcal{H}}(G) = 0$ or
- we can find a partition $\{B, U_n, W_n \mid n \in \mathbb{N}\}$ of V such that

- (P1) $\eta_{\mathcal{H}}(G[B]) = 0,$
- (P2) $\{\tilde{U}_n, \tilde{W}_n \mid n \in \mathbb{N}\}$ is pairwise disjoint, where $\tilde{U}_n := B \cap \mathcal{N}_G(U_n)$ and $\tilde{W}_n := B \cap \mathcal{N}_G(W_n).$
- (P3) For $m, n \in \mathbb{N}, E(U_n, W_m) = 0$ and $E(U_n, U_m) = 0, E(W_n, W_m) = 0$ if $m \neq n,$
- (P4) $\forall x \in B : |\mathcal{N}_G(x) \cap U_n| \leq M$ and $\forall x \in U_n : |\mathcal{N}_G(x) \cap B| \leq M$ for all $n \in \mathbb{N},$
- (P5) $\forall x \in \tilde{W}_n : |\mathcal{N}_G(x) \cap (B \setminus \tilde{W}_n)| \leq M$ and $\forall x \in \tilde{B} \setminus \tilde{W}_n : |\mathcal{N}_G(x) \cap B| \leq M$ for all $n \in \mathbb{N},$
- (P6) $G[U_n]$ and $G[W_n \cup \tilde{W}_n]$ have the property $\mathcal{R}(M, \mathcal{V}|_{U_n})$ and $\mathcal{R}(M, \mathcal{V}|_{W_n \cup \tilde{W}_n}),$ respectively.

We explain in words, what the sets $B, U_n,$ and W_n are. The set of vertices $B \subseteq V$ stands for the *base* of the graph G . We recall that, by definition, $G[B]$ is the restriction of the graph G to $B,$ see the Introduction. In the case of trees, for the k th level of recursion we use $B = \{v_k\}.$ We allow more complicated situations here, for instance, $\eta_{\mathcal{H}}(B) = 0$ if B has bounded degree and weights, see also Proposition 1.1. The graphs $G[U_n]$ and $G[W_n \cup \tilde{W}_n]$ correspond to subgraphs that we want to cut out and to study in the next recursive step. The condition (P4) ensures that each element of the subgraph $G[U_n]$ is linked by at most M edges to the base. On the other hand, the graph $G[W_n]$ could be linked to the base by a large number of edges like in the previous case for trees. In this situation, we shall not consider $G[W_n]$ in the next recursive step but $G[W_n \cup \tilde{W}_n],$ which contains a part of the base. Notice that $B \setminus \bigcup_{n \in \mathbb{N}} \tilde{W}_n$ is empty in the previous setting of a tree. Note that condition (P5) makes sure that each element of the subgraph $G[W_n \cup \tilde{W}_n]$ is linked to the remaining part of the base with at most M edges. Condition (P2) ensures that the subgraphs $G[U_n]$ and $G[W_n \cup \tilde{W}_n]$ are not too close to each other. Condition (P3) tells that there are no edges between the U_n and $W_n.$ This condition can be relaxed with Lemma 2.1, by asking that each vertices is linked with at most M other ones.

Definition 4.1 is motivated by the fact that the recursive process splits the deficiency indices in a conservative way.

Lemma 4.1: Suppose that G is a locally finite graph with bounded weights satisfying (P2) – (P5). Then, using the notation of Definition 4.1,

$$\eta_{\mathcal{H}}(G) = \eta_{\mathcal{H}}\left(G\left[B \setminus \bigcup_{n \in \mathbb{N}} \tilde{W}_n\right]\right) + \sum_{n \in \mathbb{N}} \eta_{\mathcal{H}}(G[U_n]) + \eta_{\mathcal{H}}(G[W_n \cup \tilde{W}_n]). \quad (4.1)$$

Moreover, if G obeys (P1),

$$\eta_{\mathcal{H}}\left(G\left[B\setminus\bigcup_{n\in\mathbb{N}}\tilde{W}_n\right]\right)=0. \tag{4.2}$$

Proof: Equation (4.1) is a direct consequence of Lemma 2.1. By the same argument

$$0=\eta_{\mathcal{H}}(B)=\eta_{\mathcal{H}}\left(G\left[B\setminus\bigcup_{n\in\mathbb{N}}\tilde{W}_n\right]\right)+\sum_{n\in\mathbb{N}}\eta_{\mathcal{H}}(G[\tilde{W}_n]).$$

Equation (4.2) follows, since deficiency indices are non-negative. □

Finally, we prove

Theorem 4.1: Suppose that G is a locally finite graph with bounded weights satisfying property $\mathcal{R}(M, \mathcal{V})$, for a certain potential \mathcal{V} . Then $\eta(\mathcal{A}_G + \mathcal{V}) = \eta_{\mathcal{H}}(G) \in \{0, \infty\}$.

Proof: Let G be a graph fulfilling all assumptions and having finite and positive deficiency index. As in the case of trees we construct a sequence of nested subgraphs $(G_k)_{k\in\mathbb{N}}$ of G such that for all $k \in \mathbb{N}$

- $\eta_{\mathcal{H}}(G_k) \geq \eta_{\mathcal{H}}(G_{k+1}) > 0$,
- G_k satisfies property $\mathcal{R}(M)$.

We set $G_0 := G$ and construct G_{k+1} inductively from G_k . We use now Lemma 4.1. Taking advantage of (4.2) in (4.1), there is a subgraph of G_k , among the family $\{G_k[U_n(k)], G_k[W_n(k) \cup \tilde{W}_n(k)] \mid k \in \mathbb{N}\}$ with positive deficiency index. We call it G_{k+1} . By (4.1) we have $\eta_{\mathcal{H}}(G_k) \geq \eta_{\mathcal{H}}(G_{k+1})$. Thanks to (P5), G_{k+1} satisfies also property $\mathcal{R}(M)$.

As in Theorem 1.1 we conclude that there is $K \in \mathbb{N}$ so that $\eta_{\mathcal{H}}(G_k)$ is constant for all $k \geq K$. Now consider $\tilde{G}_k := G_k[V_k \setminus V_{k+1}]$. By Lemma 2.1, we infer $\eta_{\mathcal{H}}(\tilde{G}_k) = \eta_{\mathcal{H}}(G_k) - \eta_{\mathcal{H}}(G_{k+1}) = 0$, for $k \geq K$. By construction there are at most M connections per vertex between G_k and G_{k+1} . By a last application of Lemma 2.1, we obtain $0 < \eta_{\mathcal{H}}(G_K) = \sum_{k=K}^{\infty} \eta_{\mathcal{H}}(\tilde{G}_k) = 0$. This is the desired contradiction. □

We finish by mentioning a possible generalization.

Remark 4.1: In the previous result, we do not suppose more than having bounded weights. The main examples we have in mind are simple graphs. However if one considers weighted graphs such that $\inf(E(V \times V) \setminus \{0\}) = 0$, using (2.6), one can relax the hypothesis on the uniformity in M , which is implemented in Definition 4.1.

ACKNOWLEDGMENTS

We would like to thank Hermann Schulz-Baldes, Vladimir Georgescu, Andreas Knauf, and Mathias Rafler for helpful discussions. We also thank the referee for his comments and suggestions.

APPENDIX: STABILITY OF THE DEFICIENCY INDICES OF A SYMMETRIC OPERATOR

Given a closed and densely defined symmetric operator S , one has the obvious inclusion $\mathcal{D}(S) \subset \mathcal{D}(S^*)$. In fact, given $z \in \mathbb{C} \setminus \mathbb{R}$, one gets the topological direct sum

$$\mathcal{D}(S^*) = \mathcal{D}(S) \oplus \ker(S^* + z) \oplus \ker(S^* - \bar{z}). \tag{A1}$$

One also knows that $z \mapsto \dim(\ker(S^* - z))$ is constant on the two connected components of $\mathbb{C} \setminus \mathbb{R}$. Note also that $\dim(\mathcal{D}(S^*)/\mathcal{D}(S)) = \eta_-(S) + \eta_+(S)$. We refer to [Ref. 19 Section X.1] for an introduction to the subject.

For the convenience of the reader and as we were not able to locate a proof in the literature, we recall the following useful and well-known fact. It is essentially due to Kato and Rellich.

Proposition A.1: Given two closed and densely defined symmetric operators S, T acting on a complex Hilbert space and such that $\mathcal{D}(S) \subset \mathcal{D}(T)$. Suppose there are $a \in [0, 1)$ and $b \geq 0$ such that

$$\|Tf\| \leq a\|Sf\| + b\|f\|, \text{ for all } f \in \mathcal{D}(S). \quad (\text{A2})$$

Then, the closure of $(S + T)|_{\mathcal{D}(S)}$ is a symmetric operator that we denote by $S + T$. Moreover, one obtains that $\mathcal{D}(S) = \mathcal{D}(S + T)$ and that $\eta_{\pm}(S) = \eta_{\pm}(S + T)$. In particular, $S + T$ is self-adjoint if and only if S is.

Note that if S is self-adjoint, i.e., $\eta_{\pm}(S) = 0$, the above result is the standard Kato-Rellich theorem, e.g., [Ref. 19, Theorem 10.12]. In the proofs of this article, we use this result in the case $a = 0$ and $\eta_{-}(S) = \eta_{+}(S)$. In this setting, one can avoid this general result and repeat a shorter argumentation, coming from.¹¹ We explain this alternative approach at the end of the proof of Lemma 2.1. Finally, we point out that all the results about deficiency indices of this article are stable under the above class of perturbation, i.e., (A2) with $a \in [0, 1)$.

Proof: Let $\theta \in [-1, 1]$. Note that $W_{\theta}|_{\mathcal{D}(S)} := (S + \theta T)|_{\mathcal{D}(S)}$ is symmetric and closable. Its closure is denoted by W_{θ} . Using (A2), one sees that the graph norms of S and of W_{θ} are equivalent on $\mathcal{D}(S)$. Then, we infer that W_{θ} is closed, symmetric and with domain $\mathcal{D}(W_{\theta}) = \mathcal{D}(S)$. In particular, $\mathcal{D}(S + T) = \mathcal{D}(S)$.

We concentrate on the deficiency indices. It is enough to consider the case $a \in (0, 1)$ and $b > 0$. Notice first that, for $f \in \mathcal{D}(S)$ and $\varepsilon > 0$, one obtains $\|Tf\|^2 \leq a^2(1 + \varepsilon)\|Sf\|^2 + b^2(1 + 1/\varepsilon)\|f\|^2$ for all $\varepsilon > 0$. Then, since S is symmetric, we derive that

$$\|Tf\|^2 \leq \alpha^2 \|(S \pm i\gamma)f\|^2, \text{ for all } f \in \mathcal{D}(S), \quad (\text{A3})$$

and where $\alpha^2 = (1 + \varepsilon)a^2$ and $\gamma = \sqrt{b^2/(\varepsilon a^2)}$. Taking ε small enough, we reduce to the case $\alpha \in (0, 1)$ and $\gamma \geq 1$. Take now

$$\theta_1, \theta_2 \in [-1, 1], \text{ so that } |\theta_1 - \theta_2| < \frac{(1 - \alpha)}{\alpha}. \quad (\text{A4})$$

We now prove

$$\ker((W_{\theta_1})^* \pm i\gamma) \cap (\ker((W_{\theta_2})^* \pm i\gamma))^{\perp} = \ker((W_{\theta_1})^* \pm i\gamma) \cap \text{ran}(W_{\theta_2} \mp i\gamma) = \{0\}. \quad (\text{A5})$$

Given H a closed symmetric and densely defined operator, by considering $\text{Im}\langle y, (H \pm i\gamma)y \rangle$, one sees that $\|(H \pm i\gamma)y\| \geq \gamma\|y\|$ for all $y \in \mathcal{D}(H)$ and that the range of $(H \pm i\gamma)$ is closed. Hence, the first equality of (A5) holds true.

Take $x \in \mathcal{D}((W_{\theta_1})^*) \setminus \{0\}$ and in the intersection in the lhs of (A5). We finish the proof for the minus sign. The other case is done analogously. We infer that there is $z \in \mathcal{D}(S) \setminus \{0\}$, such that $(W_{\theta_2} + i\gamma)z = x$. Then,

$$0 = \langle (W_{\theta_1})^* - i\gamma)x, z \rangle = \langle x, (W_{\theta_1} + i\gamma)z \rangle = \|x\|^2 + (\theta_2 - \theta_1)\langle x, Tz \rangle. \quad (\text{A6})$$

Now, with (A3), we infer $(1 - \alpha)\|Tz\| \leq \alpha\|(W_{\theta_2} + i\gamma)z\|$. Using the latter with (A4) and (A6), we derive

$$\|x\| \leq |\theta_1 - \theta_2| \cdot \|Tz\| < \|(W_{\theta_2} + i\gamma)z\| = \|x\|,$$

which is a contradiction. This proves (A5) and therefore $\dim \ker((W_{\theta_2})^* \pm i\gamma) \geq \dim \ker((W_{\theta_1})^* \pm i\gamma)$, under the hypothesis (A4). One deduces easily that $\dim \ker((W_{\theta})^* \pm i\gamma) = \dim \ker(S^* \pm i\gamma)$, for all $\theta \in [-1, 1]$. To conclude, we recall that, given a symmetric operator H , one has that $z \mapsto \dim(\ker(H^* - z))$ is constant on the two connected components of $\mathbb{C} \setminus \mathbb{R}$. \square

We now give a direct application to Jacobi matrices, which act on $\ell^2(\mathbb{N})$. Given A , the closure of a three-diagonal symmetric Jacobi matrix with $a_n \in \mathbb{R}$ on the diagonal and $b_n > 0$ on the upper diagonal, it is well known, e.g., [Ref. 3, page 504], that if $\sum_{n \in \mathbb{N}} 1/b_n = \infty$ and with no condition on the sequence $(a_n)_n$, then $A^* = A$. We give a generalisation in Proposition 1.1 (2). With again no condition on the diagonal elements, we prove now

- ¹⁷ Mohar, B. and Woess, W., "A survey on spectra of infinite graphs," *Bull. London Math. Soc.* **21**(3), 209–234 (1989).
- ¹⁸ Müller, V., "On the spectrum of an infinite graph," *Numer. Linear Algebra Appl.* **93**, 187–189 (1987).
- ¹⁹ Reed, M. and Simon, B., *Methods of Modern Mathematical Physics, Tome I–IV: Analysis of Operators* (Academic, New York, 1980).
- ²⁰ Wojciechowski, R., Stochastic completeness of graphs, Ph.D. dissertation, 2007.
- ²¹ Wojtylak, M., "A criterion for self-adjointness in a Krein space," *Bull. London Math. Soc.* **40**, 807–816 (2008).
- ²² Wojtylak, M., On determining the domain of the adjoint operator, preprint arXiv:1102.4969v1.