

Internship Report  
Masters in Product Design Engineering

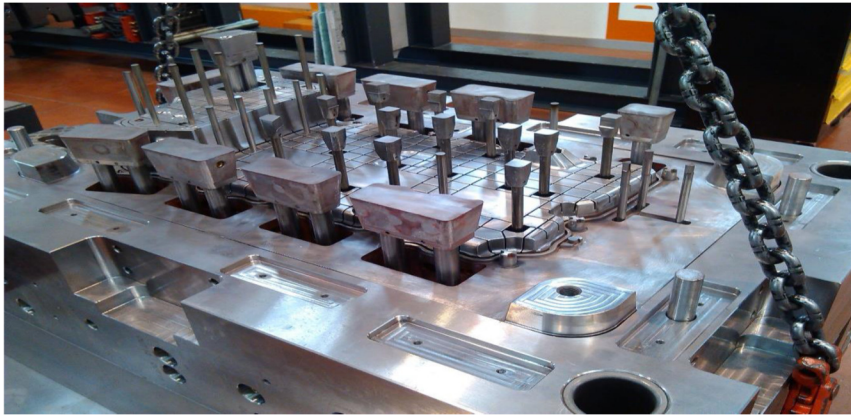

*Subtractive and Additive Manufacturing Technology in  
Moulding Industry*

**Name: Kotha Vinod Kumar**

Leiria, January, 2016

*Esta página foi intencionalmente deixada em branco*

Internship Report  
Masters in Product Design Engineering

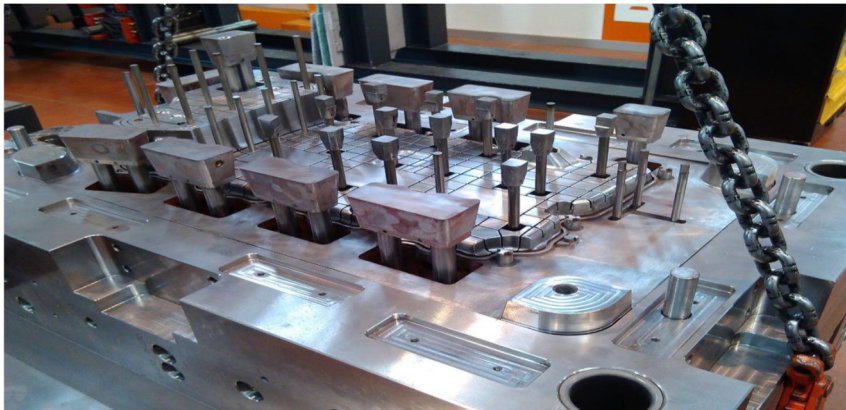

*Subtractive and Additive Manufacturing Technology in  
Moulding Industry*

**Name: Kotha Vinod Kumar**

Master's internship carried out under the supervision of Professor Carlos Capela and Professor Henrique Amorim Almedia, Professor of the School of Technology and Management of the Polytechnic Institute of Leiria.

Leiria, January, 2016

*Esta página foi intencionalmente deixada em branco*

## **Acknowledgement**

I thank all the teachers of the School by the way they taught during my internship, making me develop, evolve and get knowledge in an easier way that would otherwise be nearly impossible. Some more affordable than others, but generally all have contributed to my Internship.

I also want to thank my Advisor, Mr. Carlos Capela and Henrique Amorim Almedia for his willingness, for accepting my Internship application and their support during the Internship.

I thank my supervisors, Carlos Capela and Henrique Amorim Almedia, for guiding this Internship report, without their knowledge, guidance and their supervision would be more complicated.

I could not fail to thank the company's employee personally DRT with which I was received, the help that was provided for me with whom, I had more direct contact.

I would also like to thank the head of the DRT, Mr. Mario for guidance, advice and help provided from the beginning, even before, I had begun my Internship.

I also want to thank my family and friends for their contribution and support to overcome all the challenges during my learning process.

*Esta página foi intencionalmente deixada em branco*

## **Resumo**

Este relatório é uma revisão do aditivo e técnicas de fabricação de subtração. Abordagem tenha residido em grande parte no reino de prototipagem, onde os métodos de produção de objetos sólidos de forma livre complexas diretamente de um modelo de computador específico sem parte ferramentas ou conhecimento iniciado. Mas essas tecnologias estão a evoluir de forma constante e estão começando a abranger os sistemas relacionados de adição de material, subtração, montagem e inserção de componentes feitos por outros processos. Além disso, esses vários processos de subtração aditivos estão começando a evoluir em técnicas de fabricação rápidos para produtos customizados em massa, longe de prototipagem rápida estreitamente definida. Tomando esta idéia longe o suficiente para baixo da linha, e vários anos, portanto, uma reestruturação radical da fabricação poderia ter lugar. Não só o time to market ser reduzidos, de fabricação própria passaria de uma base de recursos para uma base de conhecimento e de produção em massa de produtos de uso único para customizados em massa, de alto valor, produtos de ciclo de vida. No momento da visita do painel, a maioria das pesquisas e desenvolvimento foi focado no desenvolvimento avançado de tecnologias existentes, melhorando o desempenho de processamento, materiais, ferramentas de modelagem e simulação, e ferramentas de design para permitir a transição a partir de protótipos para produção de uso final partes.

*Esta página foi intencionalmente deixada em branco*



## **Abstract**

This report is a review of additive and subtractive manufacturing techniques. This approach (additive manufacturing) has resided largely in the prototyping realm, where the methods of producing complex freeform solid objects directly from a computer model without part-specific tooling or knowledge. But these technologies are evolving steadily and are beginning to encompass related systems of material addition, subtraction, assembly, and insertion of components made by other processes. Furthermore, these various additive processes are starting to evolve into rapid manufacturing techniques for mass-customized products, away from narrowly defined rapid prototyping. Taking this idea far enough down the line, and several years hence, a radical restructuring of manufacturing could take place. Manufacturing itself would move from a resource base to a knowledge base and from mass production of single use products to mass customized, high value, life cycle products, majority of research and development was focused on advanced development of existing technologies by improving processing performance, materials, modelling and simulation tools, and design tools to enable the transition from prototyping to manufacturing of end use parts.

**KEYWORDS:** Plastic Injection, Mould, Project Design, DMLS

*Esta página foi intencionalmente deixada em branco*

## List of Figures

Figure 1 - Old Building DRT .....	2
Figure 2 - New Building DRT .....	2
Figure 3 - Ground plan of DRT .....	4
Figure 4 - Drawing Room.....	4
Figure 5 - Six Axis CNC machine and CAM room .....	5
Figure 6 - Machine Erosion CNC machine .....	6
Figure 7 - Bench .....	7
Figure 8 - Injection machine.....	8
Figure 9 - Designing Room .....	10
Figure 10 - Manual Grinding.....	12
Figure 11 - CNC Machine .....	18
Figure 12 - Working Principle of CNC Machine .....	19
Figure 13 - Block diagram of open loop system .....	20
Figure 14 - Block diagram of Close loop system .....	20
Figure 15 - (a) Ball Screw in CNC Machine, (b) Ball Screw Structure .....	22
Figure 16 - Linear Transducer .....	23
Figure 17 - Incremental and Absolute Rotary Encoder.....	23
Figure 18 - Tachogenerator .....	23
Figure 19 - Display Unit for CNC machine .....	24
Figure 20 - Sample tool .....	26
Figure 21 - Abrupt Transitions from Thin to Thick .....	28
Figure 22 - Rib Design .....	29
Figure 23 - Avoiding Sharp Corners .....	30
Figure 24 - CNC Wire Cut EDM Machine.....	33
Figure 25 - CNC Wire Cut EDM Machine.....	33
Figure 26 - Erosion with Penetration.....	34
Figure 27 - Erosion with Dielectric .....	35
Figure 28 - To get better understanding how these is developed is explained in Erode 3-boxes .....	35
Figure 29 - Cell.....	36
Figure 30 –Graphite rod .....	38
Figure 31 - Electrodes measuring machine .....	40
Figure 32 - Electrodes .....	40
Figure 33 - Rotary burrs list that exist in every CNC machine .....	41
Figure 34 - Thermal heating machine for changes rotary burrs .....	42
Figure 35 - CNCroulette 3X.....	42

Figure 36 - Draft angle analysis .....	43
Figure 37 - CAD Model and Finished Path.....	51
Figure 38 - Conformal cooling .....	53
Figure 39 - Step by step procedure of DMLS .....	54
Figure 40 - Machine DMLS .....	55
Figure 41 - Metal powder used in DMLS.....	56
Figure 42 - Parts produced from DMLS.....	59
Figure 43 - Conventional cooling.....	60
Figure 44 - Conformal cooling .....	61

## List of Tables

Table 1 - Types of Stems.....	37
Table 2 - All surface roughness is measured in Ra (roughness average) .....	52

*Esta página foi intencionalmente deixada em branco*

## List of Symbols

PVT	Pressure Volume Temperature
P/L	Parting Line
AM	Additive Manufacturing
SLA	Stereo lithography
FDM	Fused Deposition Moulding
DMLS	Direct metal laser sintering
LOM	Laminated Object Manufacturing
SLS	Selective Laser Sintering
SLM	Selective Laser Melting
LMD	Laser Metal Deposition
STL	Standard Tessellation Language
ABS	Acrylonitrile butadiene styrene
CNC	Computer Numerical Control

*Esta página foi intencionalmente deixada em branco*



# Table of Contents

ACKNOWLEDGEMENT.....	V
RESUMO .....	VII
ABSTRACT .....	IX
LIST OF FIGURES .....	XI
LIST OF TABLES .....	XIII
LIST OF SYMBOLS.....	XV
TABLE OF CONTENTS .....	XVII
1. INTRODUCTION.....	1
2. COMPANY OVERVIEW .....	2
2.1 COMPANY HISTORY .....	2
2.2 FACILITIES AND EQUIPMENT.....	3
2.2.1 Design / Project.....	4
2.2.2 Machining (CNC) .....	5
2.2.3 Erosion.....	6
2.2.4 Bench .....	7
2.2.5 Injection .....	8
2.2.6 Integration in company .....	9
2.2.7 Design .....	9
3. SUBTRACTIVE MANUFACTURING AND ADDITIVE MANUFACTURING .....	13
3.1 ADDITIVE MANUFACTURING V/S SUBTRACTIVE MANUFACTURING.....	14
4. CNC.....	17
4.1. WORKING PRINCIPLES OF CNC MACHINE.....	18
4.2. CONTROL SYSTEMS .....	19
4.3. ELEMENTS OF CNC MACHINE .....	20
4.4 IMPORTANT TERMS RELATED TO CNC MACHINING .....	24
5. EDM.....	31
5.1. EROSION WITH WIRE.....	31
5.2. EROSION WITH PENETRATION .....	34
5.3 CASE STUDY: FEASIBILITY STUDY ON DRAFT ANGLE .....	43

6. DMLS.....	45
6.1. DEFINITIONS.....	45
6.2. MECHANICS.....	46
6.3. PARAMETERS AND DENSIFICATION.....	49
6.4 PROCESS STEPS .....	50
6.5. WORKING PRINCIPLE .....	53
6.6. DMLS MACHINE .....	54
6.7. RESEARCH AREAS .....	56
6.8. ADVANTAGES AND LIMITATIONS OF DMLS.....	58
6.8.1. Applications.....	58
6.8.2. Limitations.....	60
6.9 CASE STUDY: FEASIBILITY STUDY ON COOLING .....	60
7. PROS AND CONS OF ADDITIVE AND SUBTRACTIVE TECHNOLOGY .....	62
8. CONCLUSION AND FUTURE WORK.....	64
9. REFERENCES.....	66
ANNEXES .....	68

# **1. Introduction**

This document is a study about mould in plastic injection Moulding and additive manufacturing technique used in moulding industry. I would also like to make a brief presentation of the company DRT, where I performed an internship as a Product Design Engineer for a duration of nine months. I have been in the moulding industry for some time now and have got practical aspect of the work process. Therefore, along with Engineer Mario (supervisor in company) and Professor Carlos Capela and Henrique Amorim Almedia (academic supervisor), it was decided to make a report on internship relating to the mould making industry. Along with the internship report, developments in additive manufacturing pose to the moulding industry was to be developed.

In the internship program, I had worked in the production area around 8 months because it was important to have an understanding about what moulds are and how they are made. During the process, I gained knowledge about different components of mould, machining processes, adjustment of moving components, parameters influencing plastic injection molding and problem solving methods. I was also provided training in CREO software for mould designing during this time. It was interesting to understand how the design has to comply the Mould. Later, during the last few weeks of internship, I came back to production area in order to understand and reason each and every step of mould making process. This helped me to relate the process of designing and mould production in a better way. This report has a brief description of what I learnt during the course of internship.

## 2. Company Overview

### 2.1 Company History

DRT was founded in May 1994 and follows the slogan since that time: "It's not just change, it is growth. Not only moulds but also moulds and arts."



Figure 1 - Old Building DRT (DRT Moldes, 2012)

On June 27, 2013 the new factory was inaugurated in the Industrial Area of Cova das faias. This new factory was a huge step for the ESRD group, as it was much better in every way in their old it was a little further from the Industrial Zone in Regueira de Pontes.



Figure 2 - New Building DRT (DRT Moldes, 2012)

This opening allowed DRT to employ more workers and vary its range of types of moulds, as the functions now played by these new

facilities has provided the creation, design and engineering and tool management, thus being able to compete with the "big" international market.

An investment of about 12 million euros was made that did strengthen the position of ESRD in this market sector, thus making an increase in production as well as increasing exports

At the moment, the DRT has approximately 120 employees and currently exports to Germany, Russia, Spain, France, Mexico, Portugal, India, and Austria.

The new facilities are located at the address: Rua dos Marinheiros, lota 6 No. 146 Industrial Area Cova das Faias- ZICOFA 2415-806 Marrazes – Leiria

DRT also have a page on the Internet at: [www.drtemouldes.com](http://www.drtemouldes.com)

## **2.2 Facilities and Equipment**

This is the plan and layout of the company, on the 1st floor is the part of the drawing and offices which is not visible from this plan. For easier to be appreciated:

- Benches Zone
- Erosion zone
- Machining Zone
- Injection Zone
- Zone reception, restaurant and some meeting rooms
- Warehouse zones
- Load Zone and downloads

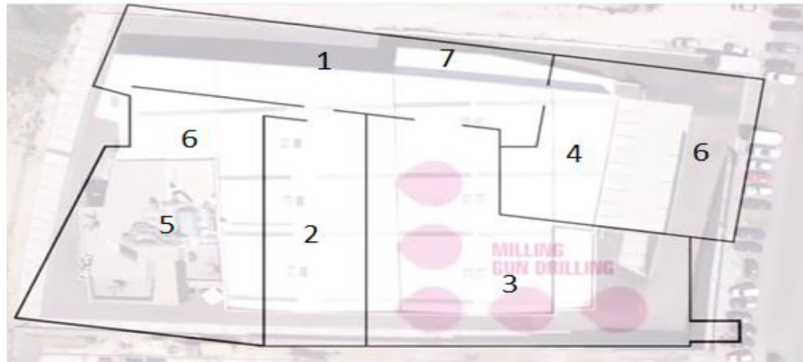

Figure 3 - Ground plan of DRT (DRT Moldes, 2012)

### 2.2.1 Design / Project

The drawing room is located on the 1st floor of the company, being one of the cleanest and nice place to work form the entire plant. This department is divided by designers of moulds and electrodes designers. In total, about 22 people, including four for electrode design and 18 for the mould design.

The company uses two programs, Catia V5 and Creo 3.0 for part of the moulds and the Power Shape for the design of part of the electrodes



Figure 4 - Drawing Room (DRT Moldes, 2012)

### 2.2.2 Machining (CNC)

In this department about 20 employs and is composed of 17 CNCs for machining.

There are several types of machining centres present in this part of the company, half of them to work in small-sized pieces and do not need to have large working desks especially the 3 axes CNC. There are also some 5-axis here the table is larger and can do the mould which are larger and more complex. There is also a machining 6-axis CNC that used for drilling deep hole, one of the most impressive machines this company doing more complex jobs.

There is another CNC also quite interesting but it is only used to make holes. It also has a rotating table, but not in angle upon itself and that the drill head bears various lengths. This structure is horizontal and can make angles from the  $-15^{\circ}$  and  $30^{\circ}$  and can make holes up to an incredible 2 meters.

There are other two centres of machining, but not in this department. These two machining centres, 3-axes and other axes 5 are to be inserted at the electrodes, which I will speak ahead.

In this department there is also a room dedicated to CAM which has about 7 computers equipped with the Mouldex 3D CAM programs where the people work and where the professionals who have a machining Centre in charge are also entitled to use for programming.



Figure 5 - Six Axis CNC machine and CAM room (DRT Moldes, 2012)

### 2.2.3 Erosion

This department is of those we have few workers, total 4 because there are two machines for each employee. This part consists of eight CNC machine erosion penetration, the second wire cutting machines CNC and the other wire drilling machine.

Also in this department there is a cell which includes two machining centres but to make graphite electrodes need not have a large size compared to machining centre of steel, with a 3 axis and 5 axes. It is further constituted by two warehouses which take about 180 electrodes, a robot that transports electrodes for warehouses electrode and a measuring machine.

There is also a compartment near the cell that is where you prepare the graphite making the cut and fixation. This department consists of an electric saw, a press and a manual milling machine.

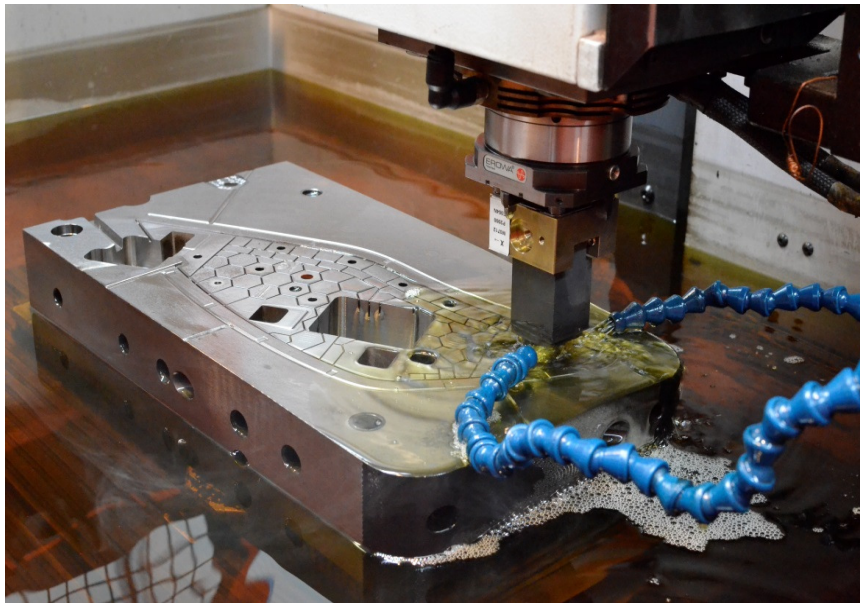

Figure 6 - Machine Erosion CNC machine (DRT Moldes, 2012)



### 2.2.4 Bench

Part of the bench may be one of the Interesting areas and busy, all the time because this part is where we begin to assembly the mould.

This department has about 20 people.

It comprises about work, each equipped with essentially tools for adjustment and assembly of moulds.

There is a press that this department reaches the 2,000 tons of clamping force, a central polishing which comprises an isolated room if any dust that may arise on the part of the stands, this being equipped with specific materials and light enough to better see mordant the finish area. There is also a room for the laser welding isolated visually as its light is very harm to view. Although the bench is part of warehouse with everything one needs to work along the lines as sandpaper until the number 1200, paints, hundreds of settings screws, drills, electrical parts, etc.



Figure 7 - Bench (DRT Moldes, 2012)

### 2.2.5 Injection

Injection moulding moulds and high pressure die casting dies are fabricated to a standard mould set. The standard mould set consists of two clamp plates, two cavity plates, guiding elements between them, an optional back plate, two risers and an ejector set. Ejector set consists of an ejector base plate, an ejector retaining plate and an optional set of buffer plates. Guiding elements are guide pillars, guide sleeves and centring sleeves in each corner of the mould.

This injection moulding process may be used for production in large quantities and pieces of many different sizes. The material of choice is melted and injected under pressure into a mould, and the area of the cavity that will determine the shape that is intended in the final part.

The injection moulding process is considered by many ways the best choice for economically producing a large scale, but nevertheless the material cost is often significant.

The cycle of a mould during injection moulding is as follows:

- a) Mould Closing
- b) Injection advance unit
- c) Injection of plastic material into the mould
- d) Cooling the mould and consequently the moulded part
- e) Opening the mould
- f) Advancement of extractors

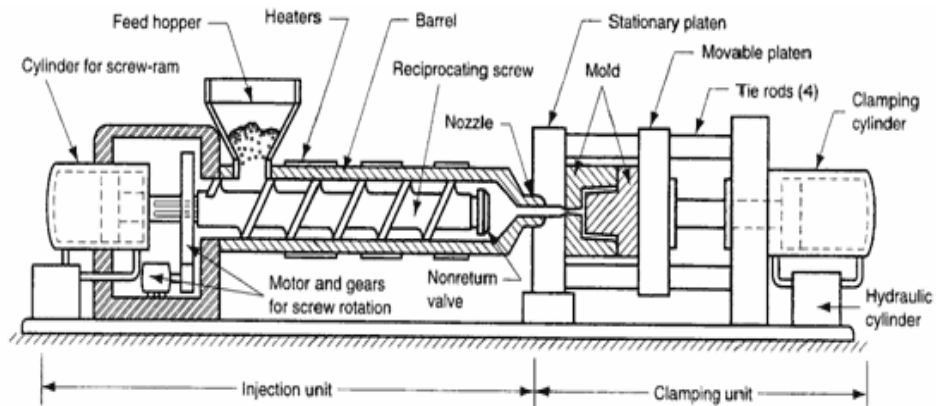

Figure 8 - Injection machine (CustomPart.net, 2007)

### **2.2.6 Integration in company**

Integration in the DRT was good. Even before starting the Internship I knew two workers of this company who gave me good references.

The day I started the Internship, on 12 March, the Chief decided that I should begin in the area of the CNC. I was then Left with Mr. Pedro, one of CNC worker of the most experienced and knowledgeable of what he do. Over 3 month I was in the same department and I was transferred to the drawing area, where I stayed about two weeks in charge of Mr. José Gabriel, a man with good sense of humour and that helped me to interact with other employees of this department. The next step was to understand about the electrode design, but this has not happened since I was referred to the cell.

Both in part from the stands, drawing and erosion people were friendly and available.

In short, since the beginning of the Internship to its end I felt integrated because the environment has always been good.

### **2.2.7 Design**

As had been said earlier, this drawing room is divided by designers of moulds and electrodes designers. On the first day I went to a mould designer, Mr. José Gabriel was already working on a template with him for a few months.

What is CAD? The CAD, being an English acronym which translated means Aided Design or Computer Aided Design, is a generic name that is attributed techniques used to produce technical drawings and is used in a series of areas.

This type of program has tools for constructing different geometric shapes and three-dimensional shapes.

The company uses two programs, Catia V5 and creo 3.0 for part of the moulds and the Power Shape for the design of part of the electrodes.



Figure 9 - Designing Room (DRT Moldes, 2012)

I saw that there was a planning of the moulds where such was visible:

- Preliminary + Mould flow Delivery
- Preliminary Approval + Mould flow / delivery of the list of materials
- 3D models of Delivery + beginning of Milling
- Home Erosion
- Structures Delivery Systems
- Home of the bench

The times varied depending on the size and complexity of the mould. I noticed that it is then a work order for everything to be done as quickly and as well economic. At first, the client sends the piece that he want to be made that may already be a part produced by another cast, or if a new piece in digital format. The play is studied to know where you have to take the balances, extractors, if you need furniture elements, etc. It then made a preliminary that is sent to the customer to give his approval. Once approved, it is possible to order some of the plates, well ahead already quite work, I noticed that the designers have permanent contact with the schemers cutting steel for any changes that may be made must be communicated before the job is done. I realized also that the designer has to be in touch with the customer to say at what stage will the mould and even if the designer find a problem has to ask if the piece itself can be changed a few millimetres, for example to get the balance work perfectly. This same thing happened while I was with this gentleman and the customer left to be done these changes without any problem., As I was not allowed

to use the company's software because it could unintentionally modify or delete important things was using the well-known CAD program Solid Edge, a program that I have installed on your computer while attending the course, I was trying to keep up while Mr. Joseph, plates slide and mobile elements, This is a different work area from any other because it would use much the head instead of force, In the database that had already had stored some parts such as buffers, records, all kinds of screws, etc. So it's easier for how some parts are already made is not lost so much time drawing. When I realized, since the two weeks had passed and it was then time to move to the electrode design section. This section, which is on the same drawing room had only three hours, long enough for me to pass the program using the Power Shape and start trying to make shapes of the electrodes from measures invented by me.

### **2.2.8 Other**

This category of "other" is part of some machines that do not fit into any of the above said categories, but all are interconnected because deep down they are all necessary, some more use and importance than others but all with its value.

In this category are the 4 injection machines that the company has, all with different characteristics can be tested mould varied much physical characteristics such as types of plastics and injection forces. There are also scattered by the various sheds five grinders manuals, a rectifier automatic, plus two manual milling machines used more to less rigorous work as feet for the moulds, also has two lathes, a manual and other CNC. Chain saws for cutting steel, an apparatus for exchanging mills by heating the cones and immense bridges for carrying the moulds and their components. The maximum load for the strongest bridge that there is 35 tons, but there are more in quantity can only carry up to 5 tons



Figure 10 - Manual Grinding (DRT Moldes, 2012)

### **3. Subtractive Manufacturing and Additive Manufacturing**

Machining is any of various processes in which a piece of raw material is cut into a desired final shape and size by a controlled material-removal process. The processes that have this common theme, controlled material removal, are today collectively known as subtractive manufacturing, in distinction from processes of controlled material addition, which are known as additive manufacturing. Exactly what the "controlled" part of the definition implies can vary, but it almost always implies the use of machine tools (in addition to just power tools and hand tools).

Additive Manufacturing (AM) is defined by the American Society of Testing and Materials (ASTM) as “the process of joining materials to make objects from 3D model data, usually layer upon layer, as opposed to subtractive manufacturing, methodologies, such as traditional machining” AM methods differ from subtractive methods, such as milling or turning, by the intuitive concept that the part is being created by the incremental addition of material. Common industry names for the AM methods are: freeform fabrication, additive processes, layered manufacturing (LM), additive techniques, and additive layer manufacturing (ALM). Currently, there are seven ALM processes with the following normalized names adopted by ASTM International Committee F42 on Additive Manufacturing Technologies: Vat Photo polymerization process (commercially known as stereo lithographic), Material Jetting (ink jet printing), Binder Jetting (3d printing), Material Extrusion (fused deposition modelling), Sheet Lamination (laminated object manufacturing), Direct Energy Deposition (laser engineered net shaping), and Powder Bed Fusion [selective laser sintering (SLS), selective laser melting (SLM) , electron beam melting (EBM), direct metal manufacturing, and direct metal laser sintering (DMLS)].

### **3.1 Additive Manufacturing v/s Subtractive Manufacturing**

Both additive and subtractive manufacturing methods have their own advantages which makes them appropriate for different circumstances a brief comparison is presented.

#### **Speed**

Additive manufacturing such as done by of complex parts with a lower lead time than CNC machining. Other than production lead time, once you submit and loading your choice of thermoplastic material, no specific tooling or setup is needed. This allows you the freedom and responsiveness to shorten your prototype, development and production cycle. CNC machining requires tooling set-up and initial programming for geometries of new parts. Both additive and subtractive manufacturing require the relevant process lead-time to schedule your task.

#### **Complexity**

In DMLS manufacturing parts with complex geometry directly from your CAD files. Because of the deposition process, where material is built up in layers, central hollows and voids and internal structure are possible with high tolerance with DMLS that might not be possible with CNC machining, as DMLS builds up the product from layers of applied material. With CNC machining, some complex internal structures are not possible as there is no access for the machine tool.

#### **Customization**

Both CNC and 3D processes allow a range of parts customization. However due to the mentioned shorter setup and complex capability, 3D can manufacture individually customized parts such as medical devices which are also intended for long duration use. Five-axis CNC machines also routinely are used to produce individual dental products



## **Material**

DMLS uses a range of polymer materials including ABS, Polycarbonate, and PC/ABS, which combines light weight with high strength. CNC machining can use both polymers (such as Delrin) and a wide range of metals including aluminum, titanium, magnesium, brass and stainless and HC steels and exotic metals and alloys.

## **Function**

While some of the materials used above are used by both processes, the function and or specifications of the end product may dictate the choice of material. Each process can lend itself to contrasting end use. Product from a subtractive process is usually somewhat more suitable for long duration use. However its shorter lead time makes FDM suitable for checking fit or for producing presentation and external design models though some of the products of 3D printing are long lifetime personalized products used in the medical and dental industries.

## **Size and Finish**

Fused Deposition Modelling allows finished product sizes of up to 900 cubic cm. CNC subtractive machining can manufacture parts of up to a cubic meter square with even longer lengths possible. While 3D printing can achieve various levels of tolerance for the most accurate results, CNC machining is capable of achieving more accurate tolerances and cosmetic and surface finishes across a higher volume of parts

## **Part Quantity**

Additive manufacturing is well suited to single or small numbers of items manufacture, when the material, tolerance and finish aspects are already considered and setup time is eliminated. Subtractive CNC machining requires longer setup and programming time and operator skill. However once prototyping has been completed using additive processes, and if you are moving to larger volumes you would likely then consider moving to a more cost effective subtractive process.

## **Hybrid Processing**

As we have both capability in both additive and subtractive, we can apply the flexibility of additive with the accuracy & finish of subtractive techniques. This means that we can manufacture products with previously unachievable geometry and introduce high precision features in hybrid operations.

## 4. CNC

Computer Numerical Control (CNC) is a specialized and versatile form of Soft automation and its applications cover many kinds, although it was initially developed to control the motion and operation of machine tools.

Computer Numerical Control may be considered to be a means of operating a machine through the use of discrete numerical values fed into the machine, where the required 'input' technical information is stored on a kind of input media such as floppy disk, hard disk, CD ROM, DVD, USB flash drive, or RAM card etc. The machine follows a predetermined sequence of machining operations at the Predetermined speeds necessary to produce a work piece of the right shape and size and thus according to completely predictable results. A different product can be produced through reprogramming and a low-quantity production run of different products is justified.

**Numerical Control:** NC is the operation of M/c tool by a series of coded instructions consisting of numbers, letters of the alphabets and symbols, which the MCU (Machine Control Unit) can understand.

**Computer Numerically Controlled:** When numerical control is performed under computer supervision, it is called computer numerical control (CNC). Computers are the control units of CNC machines. A programmer enters some information in the program, but the computer calculates all necessary data to get the job done. For both NC and CNC systems, working principles are the same. Only the way in which the execution is controlled is different. Normally, new systems are faster, more powerful, and more versatile.



Figure 11 - CNC Machine (DRT Moldes, 2012)

#### **4.1. Working Principles of CNC Machine**

CNC is computerized technology by controlling the relative movements between the tool and the work piece geometrical shapes are machined. Control of these relative movements through coded letters numbers is known as Numerical Control of machine tools. NC is simply a way of electronically controlling the operations of a machine. In conventional machine operator directly controlling the machine functions. Where as in NC machine a separate media which is in between machine and operator is controlling the machine functions. These NC machines do not have any memory of their own and hence capable of only executing a simple block of information fed to it at a time. Hardware automation gave way to computer controlled automation in manufacturing process. Computer numerical control is the term used when the control system of an NC includes a computer. The availability of a dedicated computer permits new control features to be made available on CNC machines.

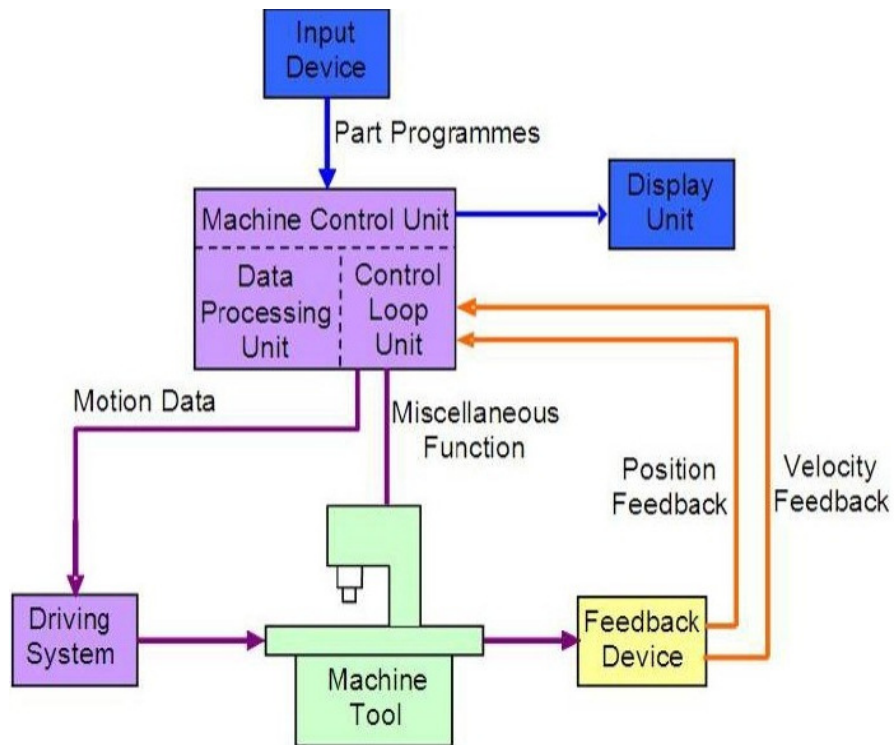

Figure 12 - Working Principle of CNC Machine (Nanfara, Uccello, & Murphy, 1995)

## 4.2. Control Systems

**Open Loop Systems:** Open loop systems have no access to the real time data about the performance of the system and therefore no immediate corrective action can be taken in case of system disturbance. This system is normally applied only to the case where the output is almost constant and predictable. Therefore, an open loop system is Unlikely to be used to control machine tools since the cutting force and loading of a machine tool is never a constant. The only exception is the wire cut machine for which some machine tool builders still prefer to use an open loop system because there is virtually no cutting force in wire cut machining.

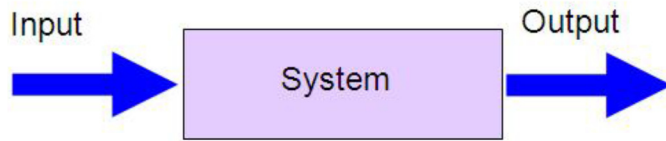

Figure 13 - Block diagram of open loop system (Nanfara, Uccello, & Murphy, 1995)

**Close Loop Systems:** In a close loop system, feedback devices closely monitor the output and any disturbance will be corrected in the first instance. Therefore high system accuracy is achievable. This system is more powerful than the open loop system and can be applied to the case where the output is subjected to frequent change. Nowadays, almost all CNC machines use this control system.

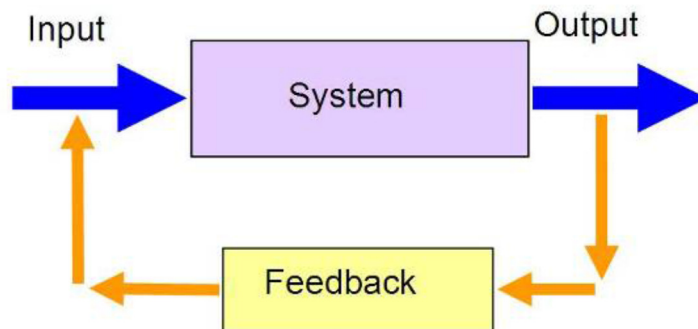

Figure 14 - Block diagram of Close loop system (Nanfara, Uccello, & Murphy, 1995)

### 4.3. Elements of CNC Machine

A CNC system consists of the following 6 major elements:

- a. Input Devices
- b. Machine Control Unit
- c. Machine Tool
- d. Driving System
- e. Feedback Devices
- f. Display Unit

### 4.3.1 Input Devices

**Floppy Disk Drive:** Floppy disk is a small magnetic storage device for CNC data input.

**USB Flash Drive:** A USB flash drive is a removable and rewritable portable hard drive with compact size and bigger storage size than a floppy disk

**Serial communication:** The data transfer between a computer and a CNC machine tool is often accomplished through a serial communication port.

**Ethernet communication:** Due to the advancement of the computer technology and the drastic reduction the cost of the computer, it is becoming more practical and economic to transfer Part programmes between computers and CNC machines via an Ethernet Communication cable. This media provides a more efficient and reliable means in part programme transmission and storage.

**4.3.2 Machine Control Unit (MCU):** The machine control unit is the heart of the CNC system. There are two sub-units in the machine control unit: the Data Processing Unit (DPU) and the Control Loop Unit (CLU).

**Control Loop Unit:** The data from the DPU are converted into electrical signals in the CLU to control the driving system to perform the required motions. Other functions such as machine spindle ON/OFF, coolant ON/OFF, tool clamp ON/OFF are also controlled by this unit according to the internal machine code

**4.3.3. Machine Tool:** This can be any type of machine tool or equipment. In order to obtain high Accuracy and repeatability, the design and make of the machine slide and the Driving lead screw of a CNC machine is of vital importance. The slides are usually machined to high accuracy and coated with anti-friction material such as PTFE and Turcite in order to reduce the stick and slip phenomenon. Large diameter Recirculating ball screws are employed to eliminate the backlash and lost motion. Other design features such as rigid and heavy machine structure; short machine table overhang, quick change

tooling system, etc. also contribute to the high accuracy and high repeatability of CNC machines.

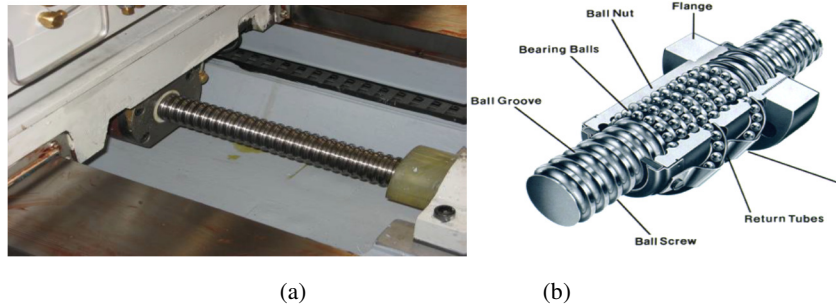

Figure 15 - (a) Ball Screw in CNC Machine, (b) Ball Screw Structure (Manuf., 2007)

**4.3.4 Driving Systems:** The driving system is an important component of a CNC machine as the accuracy and repeatability depend very much on the characteristics and performance of the driving system. The requirement is that the driving system has to respond accurately according to the programmed instructions. This system usually uses electric motors although hydraulic motors are sometimes used for large machine tools. The motor is coupled either directly or through a gear box to the machine lead screw to move the machine slide or the spindle. Three types of electrical motors are commonly used they are DC Servo motor, AC Servo motor, Stepping motor

**4.3.5 Feedback Device:** In order to have a CNC machine operating accurately, the positional values and speed of the axes need to be constantly updated. Two types of feedback devices are normally used, positional feedback device and velocity feedback device.

**Positional Feed Back Devices:** There are two types of positional feedback devices: linear transducer for direct positional measurement and rotary encoder for angular or indirect linear measurement.

**Linear Transducers -** A linear transducer is a device mounted on the machine table to measure the actual displacement of the slide in such a way that backlash of screws; motors, etc. would not cause any error in the feedback data.



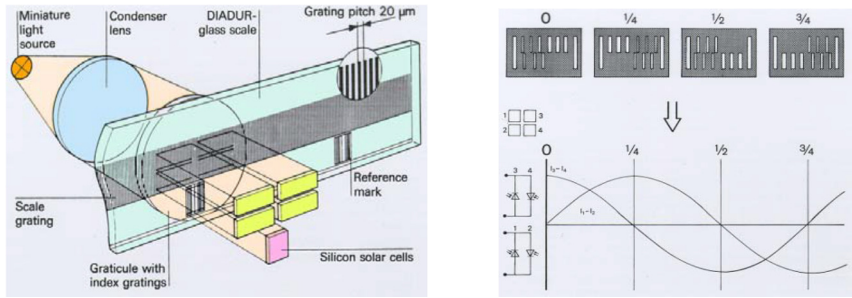

Figure 16 - Linear Transducer (Courtesy of Hidenhain) (Manuf., 2007)

**Rotary Encoders** - A rotary encoder is a device mounted at the end of the motor shaft or screw to measure the angular displacement. This device cannot measure linear displacement directly so that error may occur due to the backlash of screw and motor etc

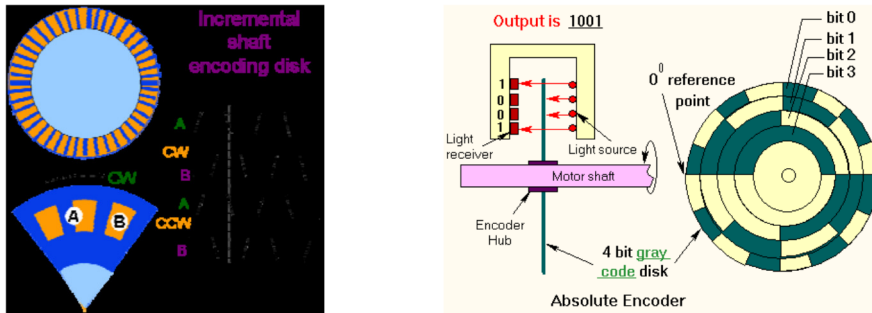

Figure 17 - Incremental and Absolute Rotary Encoder (Manuf., 2007)

**Velocity Feedback Device:** The actual speed of the motor can be measured in terms of voltage generated from a tachometer mounted at the end of the motor shaft. DC tachometer is essentially a small generator that produces an output voltage proportional to the speed.

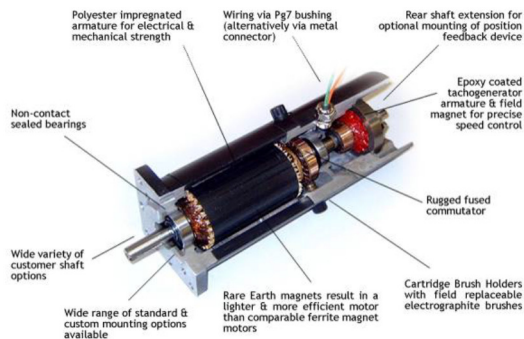

Figure 18 - Tachogenerator (Courtesy of challan) (Manuf., 2007)

**4.3.6 Display Unit:** The Display Unit serves as an interactive device between the machine and the operator.



Figure 19 - Display Unit for CNC machine (Courtesy of Heidenhai) (DRT Moldes, 2012)

## 4.4 IMPORTANT TERMS RELATED TO CNC MACHINING

**Machine Zero** - Machine zero is a point at the origin of the machine's coordinate measuring system. All the Axis movements and other dimensions are measured from this point. It is similar to the origin of coordinate measuring system.

**Machine reference point** - It refers to the initial point of return for the purpose of measuring/feedback systems. Whenever a CNC machine is switched on the feedback system has to be initialized by referring this point on every axis.

**Work Zero** - This is the origin for the measuring of dimensions of work piece. The programmer is free to select it anywhere on the drawing.

**Absolute measuring system** - In this measuring system all the dimensions are made from the work zero, which defined. The machine

control uses work zero as the reference point to position the tool during program execution. The main advantage of programming in absolute system is that any point can be readily changed without affecting subsequent dimensions.

**Incremental measuring system** - The movements are based on the change in position between two successive points. It expresses the relative distance between the current location and the next position. This type of measuring system is called Incremental Measuring system. The main advantage of this system is that sum of the dimensions must always be zero if start point and finishing point is same at the end of programming which makes it easy to check a program.

**Axis designation (conventions)** - Axis designation for each type of machine tool is suggested in the EIA (Electronic Industries Association) RS 274-B standard. This conforms to ISO Recommendations R831. The nomenclature of the three main axes (X, Y AND Z) is based on the “Left hand rule”. The thumb indicates the orientation of the X-axis; the index finger indicates the Y-Axis, and the middle finger points in the direction of the Z-axis.

**Spindle speed** - The spindle speed is the rotational frequency of the spindle of the machine, measured in revolutions per minute (RPM). The preferred speed is determined based on the material being cut. Using the correct spindle speed for the material and tools will greatly affect tool life and the quality of the surface finish.

**Feed rate** - Feed rate is the velocity at which the cutter is fed, that is, advanced against the work piece. It is expressed in units of distance per revolution for turning and boring (millimeters per revolution). For milling it is expressed in units of distance per time for milling (millimeters per minute).

**Cutting Speed** - Cutting speed may be defined as the rate (or speed) that the material moves past the cutting edge of the tool, irrespective of the machining operation used — the surface speed.

#### 4.5 CASE STUDY ON WALL THICKNESS

Product wall thickness is a key consideration when designing products for plastic injection molding. Thicker walls will offer more strength, but they are also more likely to suffer from warping as the plastic cools in the mold. Engineers and designers are usually more focused on pushing the boundaries in the other direction, and using the minimum wall thickness for injection molding they can get away with. When mass-producing plastic parts there are a number of advantages to keeping them thin and light, and the longer the production run, the more significant these benefits become:

- Thinner parts require less material, reducing material costs
- Thinner parts cool quicker, thereby shortening the molding cycle and reducing unit costs
- Thinner parts weigh less, potentially reducing shipping costs

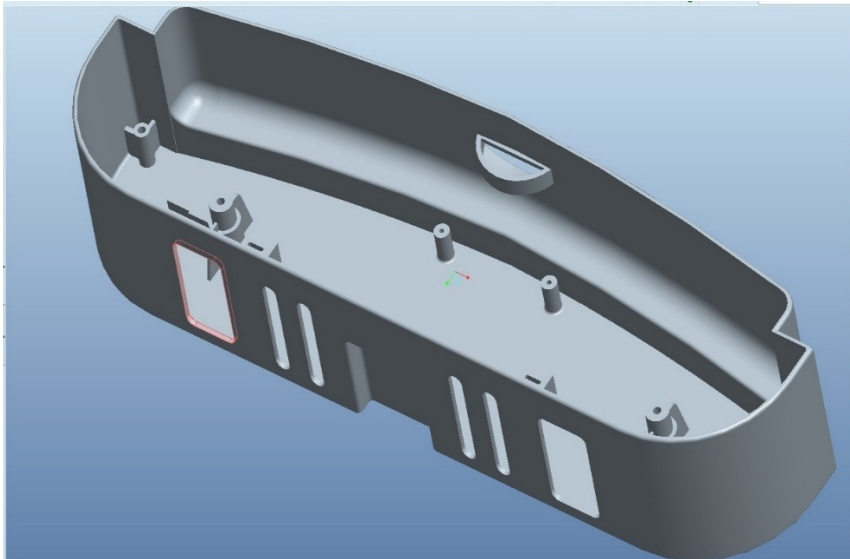

Figure 20 - Sample tool (DRT Moldes, 2012)

Cost savings are highest when components have a minimum wall thickness, as long as that thickness is consistent with the part's function and meets all mold filling considerations. As would be expected, parts cool faster with thin wall thicknesses, which means

that cycle times are shorter, resulting in more parts per hour. Further, thin parts weigh less, using less plastic per part. On average, the wall thickness of an injection molded part ranges from 2mm to 4mm (.080 inch to .160 inch). Thin wall injection molding can produce walls as thin as .05mm (.020 inch).

### **Considerations**

Generally, minimum wall thickness for injection molding is dictated by strength and the structural requirements of the product or component. We've also got to take the flow behavior of the material into account, as there is a direct relationship between the maximum achievable flow length for a given wall thickness and injection pressure. In both cases modern structural and flow analysis software will assist engineers in selecting the optimal wall thickness.

Just to add another variable into the mix, we can also use different types of plastics that have different strength and cooling properties! However, as a rule, the minimum wall thickness for conventional injection molding is 0.3mm, and even then it depends on the characteristic of the part itself. Below this it is unlikely we would be able to guarantee the results.

### **Design Advice**

From a molding perspective, it's good practice to keep wall thicknesses as uniform as possible. This is because thinner walls cool (and therefore shrink) quicker than the thicker walls, which can cause warping to occur and result in internal stresses in the product, definitely what you don't want when you're pushing the boundaries of wall thickness! When design considerations dictate that a uniform wall thickness is not possible, then the change in thickness should be as gradual as possible to avoid stress concentrations and abrupt cooling differences.

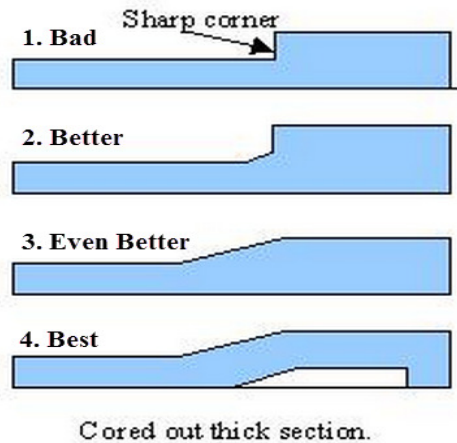

Figure 21 - Abrupt Transitions from Thin to Thick (DRT Moldes, 2012)

It's inevitable that your parts will require some variations in wall thickness due to the incorporation of structural features such as ribs, bosses and gussets. However, the transition from thin to thick should be as gradual as possible in order to avoid mold-filling phenomena such as flow hesitation or race tracking. Given a choice, molten plastic flowing inside of an injection mold cavity will always take the path of least resistance, typically towards the thicker wall sections. Flow hesitation occurs when the melted plastic flows into a thicker section while the flow in the thinner section stalls and sometimes freezes off completely, causing major problems. Race tracking occurs when the molten plastic "races" around the edges of a part due to thicker wall sections around the perimeter of the part compared to the interior wall sections. Maintaining gradual transitions from thin to thick— as seen in the diagram—can help reduce these phenomena or eliminate them altogether, resulting in higher-quality molded parts with fewer manufacturing defects.

### **Rib Design**

Ribs are commonly used in plastic parts to provide structural integrity, prevent part warpage and aid in the integration of internal components. However, if ribs are not designed properly relative to the surfaces they're attached to, problems such as sink marks, warpage

and part failure can occur. The following rib design guidelines work well for most plastics materials:

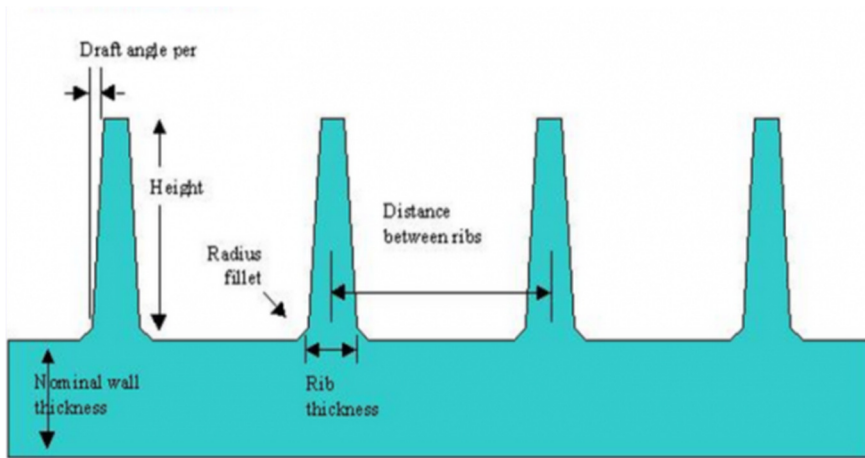

Figure 22 - Rib Design (DRT Moldes, 2012)

- Rib thickness at the base should be between 50-70% of the nominal wall thickness.
- Rib height should be 2.5 – 3X the nominal wall thickness.
- Ribs should have 0.5 – 1.5 degrees of draft (for ejection).
- Rib base radii should be 0.25 – 0.4X the nominal wall thickness.
- The distance between two ribs should be 2 – 3X the nominal wall thickness.

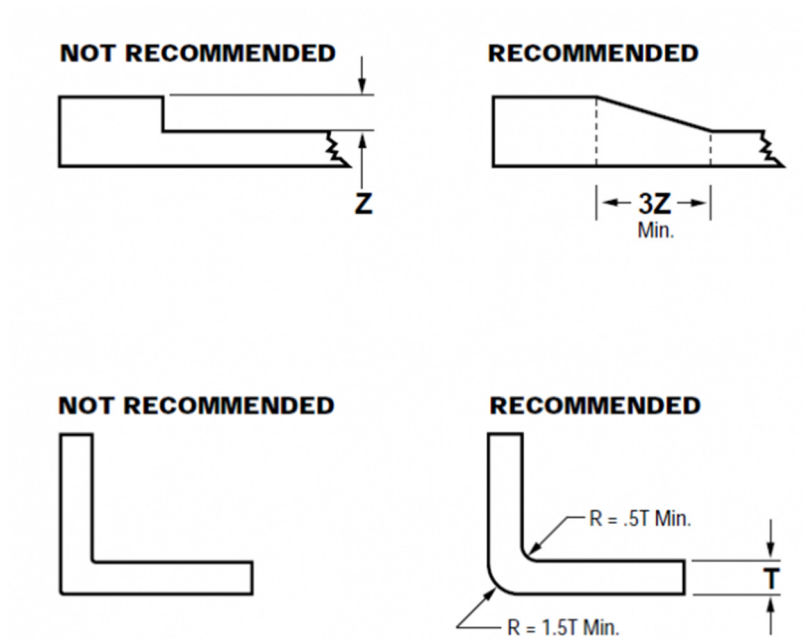

Figure 23 - Avoiding Sharp Corners (DRT Moldes, 2012)

Sharp corners in plastics parts act as stress concentrators that can lead to crazing, cracking, increased susceptibility to chemical attack and ultimately, part failure – so it’s a really good idea to avoid them at all costs. The good news, it’s usually pretty easy to add fillets or chamfers to avoid sharp corners altogether as can be seen in this diagram.



## **5. EDM**

Electric discharge machining, sometimes also known as spark machining, spark eroding, burning, die sinking, wire burning (or) wire erosion is a manufacturing process whereby a desired shape is obtained using electrical discharges (sparks). Material is removed from the work piece by a series of rapidly recurring current discharges between two electrodes, separated by a dielectric liquid and subject to an electric voltage. One of the electrodes is called the tool-electrode, or simply the "tool" or "electrode", while the other is called the work piece-electrode, or "work piece".

When the distance between the two electrodes is reduced, the intensity of the electric field in the volume between the electrodes becomes greater than the strength of the dielectric (at least in some point(s)), which breaks, allowing current to flow between the two electrodes. This phenomenon is the same as the breakdown of a capacitor (condenser). As a result, material is removed from both electrodes. Once the current stops (or is stopped, depending on the type of generator), new liquid dielectric is usually conveyed into the inter-electrode volume, enabling the solid particles (debris) to be carried away and the insulating properties of the dielectric to be restored. Adding new liquid dielectric in the inter-electrode volume is commonly referred to as "flushing". Also, after a current flow, the potential between the electrodes is restored to what it was before the breakdown, so that a new liquid dielectric breakdown can occur. Two types of erosion are used in DRT:

1. Erosion with wire
2. Erosion with penetration

### **5.1. Erosion with Wire**

In wire electric discharge machining (WEDM), also known as wire cut EDM or wire cutting, a thin single-strand metal wire, usually brass, is fed through the work piece, submerged in a tank of dielectric fluid, typically deionized water. Wire-cut EDM is typically used to cut plates as thick as 300mm and to make punches, tools, and dies from

hard metals that are difficult to machine with other methods. The wire, which is constantly fed from a spool, is held between upper and lower diamond guides. The guides, usually CNC-controlled, move in the  $x$ - $y$  plane. On most machines, the upper guide can also move independently in the  $z$ - $u$ - $v$  axis, giving rise to the ability to cut tapered and transitioning shapes (circle on the bottom, square at the top for example). The upper guide can control axis movements in  $x$ - $y$ - $u$ - $v$ - $I$ - $j$ - $k$ - $l$ . This allows the wire-cut EDM to be programmed to cut very intricate and delicate shapes. The upper and lower diamond guides are usually accurate to 0.004 mm, and can have a cutting path or kerf as small as 0.021 mm using  $\varnothing$  0.02 mm wire, though the average cutting kerf that achieves the best economic cost and machining time is 0.335 mm using  $\varnothing$  0.25 brass wire. The reason that the cutting width is greater than the width of the wire is because sparking occurs from the sides of the wire to the work piece, causing erosion. This "overcut" is necessary, for many applications it is adequately predictable and therefore can be compensated for (for instance in micro-EDM this is not often the case). Spools of wire are long — an 8 kg spool of 0.25 mm wire is just over 19 kilometres in length. Wire diameter can be as small as 20 micrometres and the geometry precision is not far from  $\pm$  1 micrometre. The wire-cut process uses water as its dielectric fluid, controlling its resistivity and other electrical properties with filters and de-ionizer units. The water flushes the cut debris away from the cutting zone. Flushing is an important factor in determining the maximum feed rate for a given material thickness. Along with tighter tolerances, multi axis EDM wire-cutting machining centres have added features such as multi heads for cutting two parts at the same time, controls for preventing wire breakage, automatic self-threading features in case of wire breakage, and programmable machining strategies to optimize the operation. Wire-cutting EDM is commonly used when low residual stresses are desired, because it does not require high cutting forces for removal of material. If the energy/power per pulse is relatively low (as in finishing operations), little change in the mechanical properties of a material is expected due to these low residual stresses, although material that hasn't been stress-relieved can distort in the machining

process. The work piece may undergo a significant thermal cycle, its severity depending on the technological parameters used. Such thermal cycles may cause formation of a recast layer on the part and residual tensile stresses on the work piece. If machining takes place after heat treatment, dimensional accuracy will not be affected by heat treat distortion.



Figure 24 - CNC Wire Cut EDM Machine (DRT Moldes, 2012)

After erode the machine is tested with the same zone through proper tools to whether the measure is correct, to ascertain whether it is necessary to remove more material or not



Figure 25 - CNC Wire Cut EDM Machine (DRT Moldes, 2012)

## 5.2. Erosion with Penetration

It is done by using a graphite electrode or copper, having been made the study of which is done in eroded area. It focuses on the hole / box or another place to start to erode. The head of the machine already set with the electrode and already in place makes orbits while eroding and the electrode to erode the steel waste, a type of sludge that will be filtered later. The electrode is not in contact into with the material being always at a certain distance in both x and z what is termed GAP. the piece is covered by a dielectric liquid and how ever the graphite is an excellent conductor of electric shock, this upon contact, the graphite begins to erode as the machine launches electric shocks to make it possible to do the required work. In this type of erosion there is a VDI scale where the roughness values by / levels is presented, it is possible to obtain the desired roughness

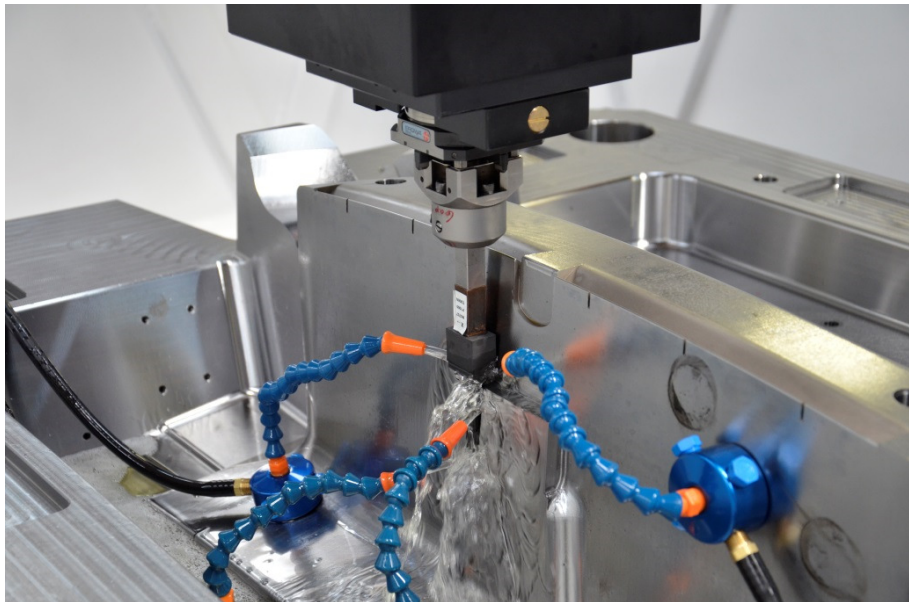

Figure 26 - Erosion with Penetration (DRT Moldes, 2012)

**5.2.1. Erosion with Dielectric:** Every experienced, expert knows that the flushing process is of utmost importance, when metals are

subjected to this procedure. The dielectric must flush away the eroded particles from the gap between electrode and work piece, otherwise they may form bridges, which cause short circuits. Such arcs can burn big holes in the work piece and in the electrode. Modern spark erosion plants therefore have a built in power adaptive control system, which increases pulse spacing as soon as this happens and reduces or shuts off the power supply completely. The more thin-bodied a dielectric and the lower its surface tension, the better it is able to meet flushing requirements.

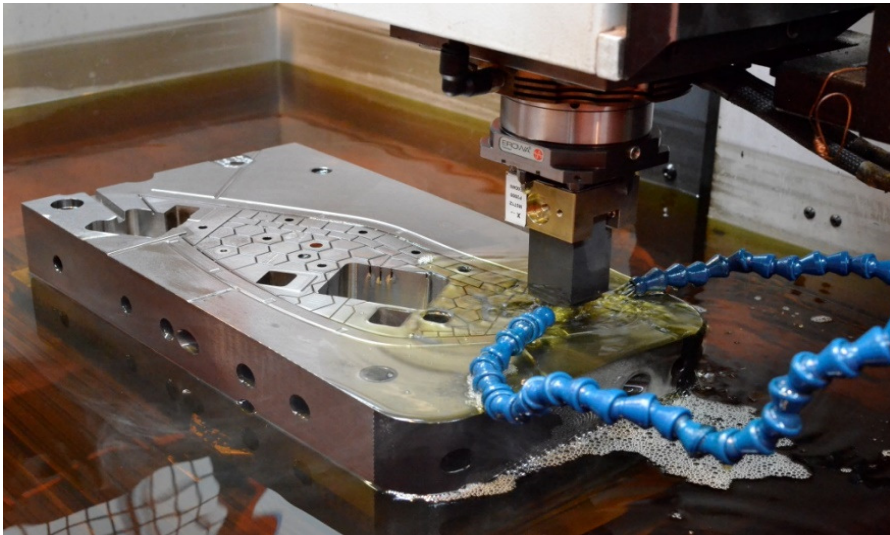

Figure 27 - Erosion with Dielectric (DRT Moldes, 2012)



Figure 28 - To get better understanding how these is developed is explained in Erode 3-boxes (DRT Moldes, 2012)



Figure 29 - Cell (DRT Moldes, 2012)

It all starts by designers in the upstairs to they bring A4 sheets indicating the graphite measurements in the rough, kind of graphite, type of rod to use, time it takes the precession machining, observations, quantity, you have mirrors and in X or Y, the value of GAP so that the machine is intended (3x, 3x or 5x / 5), developer name and identification electrode by mould piece and electrode number are included in the above sheet

ELEC. N°		M0817M01P1000E003N00	
GAP	D:0,4 A:0,4	Z Máq.	0
Programador	Agostinho Lopes	Verdade Aproximada	0,0001
Data/Hora	14/09/2012 09:30:30	Máquina	312

Centragem / Dimensiones	
MIN	MAX
X	-13,3 13,3
Y	12,5 12,5
Z	11,2 <b>64,2</b>
DIM	25 x 25 x 41

Quantidade	Especho	Materiais
2	NAO	EDM020

**Haste** 25x25

OBS.: NC Rodado = NAO

After receiving this sheet we will search to see, if there would be material required for action if it were not found, would have to fill out an internal request for an order of graphite was done with the right measures.

After the graphite arrived measurement are taken. The measurements are taken in the x, y, and z axes for e.g. (455x150x122 mm.)

After placing the graphite comes on top of the sheet to which it belongs has to go looking for kind of stems that are described in the sent sheet. In total there are 10 types of rods as shown in the following table.

Table 1 - Types of Stems

50×50 R20	Normally used / Can be used on the robot
50×50 PL	Normally used / Can be used on the robot
25×25 EW	Normally used / Can be used on the robot
15×15 EW	Normally used / Can be used on the robot
50×100 PL	Not much used / Inserted by hand
100×150 PL	Not much used / Inserted by hand
15×15 COPPER	Not much used / Inserted by hand
15×40 COPPER	Not much used / Inserted by hand
25×25 COPPER	Not much used / Inserted by hand
25×63 COPPER	Not much used / Inserted by hand

Copper rods they are used when you want to erode something that is deeper and normal stems that outwardly has 50x50x50 and hit the

piece. Another solution was to make the much longer electrode but then there would be problems both in the same machining as the erosion process to be so fragile.



Figure 30 –Graphite rod (DRT Moldes, 2012)

After arrange the types of applications in paper, rod has to proceed to the cleaning of the faces of the graphite z using a manual cutter. The graphite is then smoothed on one side to the rod to be placed perpendicular to the graphite. After the parts cleaned on one side they are separated and the manual milling cutter is replaced by a drill 6, 8 or 10mm depending on the type of stem which is desired.

After the parts are removed it is time to find your centre to carry out drilling to hold the rod in graphite. When we drill in the exact centre of the piece walked x 18 or 20 mm depending on the rod and make a hole about 20 mm in depth. After all the parts are properly pierced has to be made will thread cutting with a machine that is in the zone of the stands. Having made the thread is time to tighten the rod to graphite. These raw electrodes are measured by a meter gauge and



then have to take 1 mm to make sure that cleans well. This value is recorded on the sheet and then also be seen by erosion staff. After labels are taken.

It carries a rod to be identified with the mould number, electrode number, whether it is right or mirror and mirror in x or y, GAP and height z. Then a chip is placed on the rod and it's all arranged on the side of the cell to the table. Imagining we have 6 electrodes to place. We get the 6 electrodes and the sheet and check if the data on the labels will correspond sheet that accompanies them. Then it is checked whether all screws are tight, and the same with the chip. Then you create a folder where you put the number of the mould and start. To that folder is imported the program you want and you need to pay attention to see to that machine are directed those electrodes. After imported the programs of electrodes right and left have to edit and change for each of the 3 number electrodes. So when you open one of the programs appear three rectangles the pale pink-violet colour, which means that nothing has yet been registered

Electrodes have to separate the rights of left and we recording the pre-set each chip compared the label. Deep down you do it assign a program to each chip and each stem has a chip. In this case we assign a program equal to 3 chips that were equivalent to the right electrode of the program and we assign another program like other 3 chips that amounted to the left electrode program.

After all prepared and registered it's time to put these electrodes in one of the cell warehouses.

After put in place, close the door of the warehouse and wheel, causing the chips to go through sensors. The positions are all present on a monitor and those that are green is because they are ready to be machined and which are pale pink-violet colour are those just put and was still nothing changed, so have these six rectangles that we have to put the priority we want depending on their urgency.



Figure 31 - Electrodes measuring machine (DRT Moldes, 2012)

Supposedly the electrodes after machined should be measured with an own machine that measures to the thousandth before being taken but that does not happen because there is so much work and so little time.

What is usually done often in the case of having many electrodes with the same program is to try one to see do well, then at night when it gets to do yourself no problem because it has a well while we were present, to be sure that next they also do will do well without us playing so safe and there is no danger of the machine stop in the middle of the night with problems because of machining.



Figure 32 - Electrodes (DRT Moldes, 2012)

At the end of one electrode machining, the robot will pick you up and puts in place where fetched, then grabs the next that have the highest priority and puts the machine from which it takes earlier. When seem the pieces and if they are urgent are immediately taken to the foot of the erosion machines for use but when there is nothing pressing to do fill up boxes that take up to 12 electrodes and are put for later use. The cell always needs some maintenance and inventory records.

There are always three steps that have to do when you arrive in the morning:

- Remove the warehouse electrodes that are ready;
- Clean the cabins of CNCs;
- Check times of tools

There are about 30 different tools on each machine as we can see by this list:

**Tabela de Ferramentas HSC-300 / HSC-600**

Posição	Nome da ferramenta	Alt.-Cone	Rotação	Avanço	INCR.	INC.LAT.
1	TR16R1.0DL075G	75	13000	8300	0,5	10
2	TR12R0.5DL075G	75	13000	6000	0,5	4
3	TR12R0.5AL075G	75	13000	5500	0,1	2
4	TR10R0.5AL075G	75	13000	5500	0,08	1
5	TR08R0.3AL075G	75	13500	4200	0,08	1
6	TR06R0.3AL055G	55	12000	3800	0,06	0,1
7	TR04R0.3AL045G	45	15000	2200	0,06	0,5
8	TR02R0.2AL030G	43	16000	1500	0,05	0,25
9	TR02R0.2AL015G	42	16000	1500	0,05	0,25
10	TR01R0.2AL020G	42	16500	1000	0,04	0,1
11	TR01R0.2AL010G	40	16500	1000	0,04	0,1
12	ESF10AL075G	75	15000	4000	0,1	0,1
13	ESF08AL075G	75	15000	4000	0,08	0,08
14	ESF06AL055G	55	16000	2700	0,06	0,06
15	ESF04AL045G	45	16000	2500	0,05	0,05
16	ESF02AL030G	43	17000	1200	0,05	0,05
17	ESF02AL015G	40	17000	1200	0,05	0,05
18	ESF01AL020G	37	17500	900	0,04	0,04
19	ESF01AL010G	35	17500	900	0,04	0,04
20	ESF0.5AL005G	30	18000	600	0,04	0,04
21	TR16R1.0AL100G	100	13000	8000	0,1	4
22	TR06HITACHI	60	10000	3800	0,06	0,1
23	TR16R1.0DL100G	100	13000	8300	0,5	10
24	TR04LONGA	41	15000	2200	0,06	1
25	TR02LONGA	42	16000	1500	0,05	0,25
26	TR01LONGA	38	16500	1000	0,04	0,1
27	ESF04LONGA	42	16000	2500	0,05	0,05
28	ESF02LONGA	40	17000	1200	0,05	0,05
29	ESF01LONGA	38	17500	900	0,04	0,04
30	ESF0.5LONGA	27	18000	600	0,04	0,04

Página 1

Figure 33 - Rotary burrs list that exist in every CNC machine (DRT Moldes, 2012)

When they reached the 1100 minutes, the tools are taken and can be seen the glow at the tip meaning that the diamond bath is out. So it takes the cone with the cutter and will be sought a new mill. There is a machine that heats the cone and that they have to choose the correct heating program for the type of cone and open enough to be able to take the old mill and the other having already prepared will is so far down.



Figure 34 - Thermal heating machine for changes rotary burrs (DRT Moldes, 2012)



Figure 35 - CNCroulette 3X (DRT Moldes, 2012)

Parts made in a plastic injection moulding process can have their own unique set of possible defects. The following is one of the most

common defects associated with the plastic injection process in which I worked on

### 5.3 Case study: Feasibility Study on Draft angle

Draft angles are needed so that a plastic part can be released from the mould without distortion or damage. The high pressures of injection moulding force the plastic to touch all the surfaces of a mould's cores and cavities. The cavity becomes so tightly packed that it is often difficult to remove the part. Sometimes, shrinkage will actually make it easier to take the part out of the mould, but in other cases, shrinkage will cause the part to stick to the mould's cores. These natural occurrences call for draft angles.

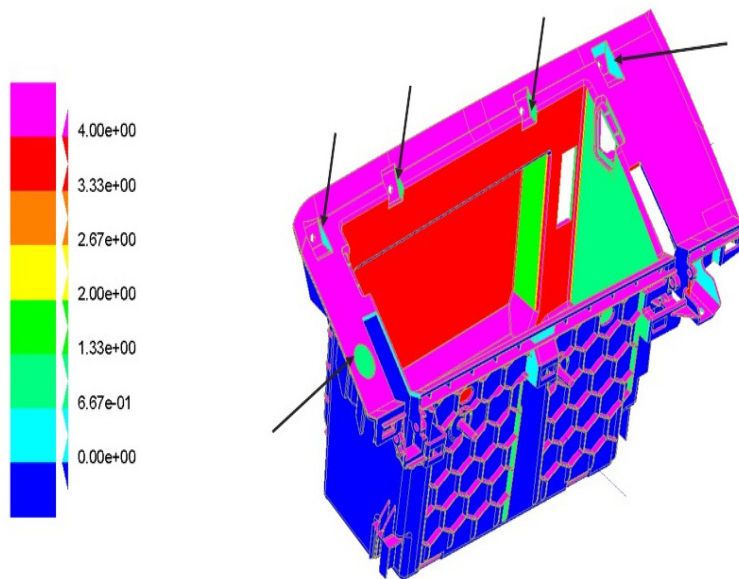

Figure 36 - Draft angle analysis (DRT Moldes, 2012)

Draft angles are needed so that a plastic part can be released from the mold without distortion or damage. The high pressures of injection molding force the plastic to touch all the surfaces of a mold's cores and cavities. The cavity becomes so tightly packed that it is often difficult to remove the part. Sometimes, shrinkage will actually make it easier to take the part out of the mold, but in other cases, shrinkage will cause the part to stick to the mold's cores. These natural occurrences call for draft angles.

No single draft angle is suitable for all parts. Each individual part requires a unique specification. Large parts call for more draft than small parts. Thin-walled parts that undergo high-pressure injection molding need more draft than parts that are subjected to lower-pressure molding. When calculating appropriate draft angles, the plastic material's shrinkage and physical properties are also considerations. Sizeable draft angles and smooth polish should be used for parts molded in strong, inelastic, abrasive and gluey materials. Smaller draft angles can be utilized on soft, malleable and slippery plastics.

From a cost and manufacturability viewpoint, the ideal draft angle is the largest angle that will not lessen the customer's satisfaction with the product. The minimum allowable draft angle is harder to quantify. Plastic material suppliers and molders are the authority on what is the lowest acceptable draft. In most instances, 1° per side will be sufficient, but between 2° and 5° per side would be preferable. If the design is not compatible with 1°, then allow for 0.5° on each side. Even a small draft angle, such as 0.25°, is preferable to none at all.

Draft angles must be provided for several part details. For example, the sidewalls that are perpendicular to the mold's parting line must be drafted. Other areas that require draft angles include mounting flanges, gussets, holes, hollow bosses, louvers and other holes. The location of the mold's parting line sometimes remains unknown, however. This lack of information makes it impossible to ascertain whether the part's draft angles should have positive or negative values. As a result, designers commonly draw the part without individual draft angles but with a general specification such as 'allowable draft 1°'.

## **6. DMLS**

It was not until the 1970's that the first powder AM methods began to appear (Systems, 2004). In 1971, Ciraud applied for a patent on a powder AM method, which was described in the patent as "the invention makes possible the manufacture of parts which can have extremely complex shapes, without the need for casting moulds" (Systems, 2004). In the latter half of the 1970s, Householder patented the first powder laser sintering system (Systems, 2004). This sintering system was described in the patent as able "to provide a new and unique moulding process for forming three-dimensional articles in layers and which process may be controlled by modern technology such as computers" (Systems, 2004). In 1992 and 1994, the first and second commercial selective laser sintering machines were shipped: the sintersation 2000 by DTM Corporation and EOSINT (P) 350 by EOS Firm respectively (Systems, 2004). In 1995, one of the first direct metal laser sintering machines, the EOSINT M 250, was installed for commercial use (Systems, 2004). This machine allowed for the best part complexity, geometry, and surface quality to date for any direct metal laser sintering machine (Systems, 2004). In 2004, the EOSINT M 270 machine series was released, featuring a solid-state fibre laser (Systems, 2004). EOS continued to develop new and exotic models of DMLS machines, even making a precious metal machine (PRECIOUS M 080) (Cerreta, Direct Metal Laser Sintering :An Overview, 2014). In 2013, EOS released it latest and most advanced machine (EOS M 290) for the manufacturing of high performance metal components (Cerreta, Direct Metal Laser Sintering :An Overview, 2014)

### **6.1. Definitions**

In current literature, DMLS is defined differently by various publication authors (Bewilogua, et al., 2009), (Systems, 2004), (Sateesh, 2014, pp. 772-779) . Levy distinguished multiple metal AM methods and their processing conditions (Bewilogua, et al., 2009) and his definition of DMLS is most appropriate for the focus of this work. Levy defined DMLS as a single stage part building based on a liquid

phase sintering (LPS) process (Bewilogua, et al., 2009). This definition distinguishes DMLS from two similar SLS methods that produce a solid metal part, which are often mistaken for DMLS. The first method differs from DMLS in that a metal part is created by laser sintering a powdered material containing the desired metal particles, which are covered in a low melting point polymer (commonly called a “binder”), to form what is known as a “green part”. In this indirect method, only the binder is melted, which requires the use of post processing and heat treatment (usually conventional sintering in an industrial furnace) to create the final part. Similarly, the second method differs from DMLS in that a mixture of metal powders is used. One metal powder has a lower melting temperature than the other, which allows for selective melting of one metal, but commonly results in poor mechanical properties of the final part.

## 6.2. Mechanics

In order to understand the basic mechanics of DMLS, one must investigate the following elements of DMLS: binding mechanisms (<http://www.protolabs.co.uk/additive-manufacturing>, n.d.), parameters and their relationship to densifications, processing steps (Dewidar M. M., 2002), and equipment (Dewidar M. M., 2002), Rapid Prototyping.

**Binding Mechanism:** According to the Metal Handbook, “sintering is a thermally activated process (with or without external pressure application), whereby the powder particles are made to bond together, changing physical and mechanical properties, and developing toward a state of maximum density, i.e. zero porosity, by occurrence of atomic transport” (Cerreta, Direct Metal Laser Sintering :An Overview, 2014). Sintering is crucial to the DMLS process, and is governed by the following parameters: temperature, time, and geometry of powdered particles, composition of the powder Mix, density of the powder compact, and composition of the protective atmosphere in the sintering furnace (Dewidar M. M., 2002).

Kruth found that SLS technologies can be categorized by four binding mechanisms: solid state sintering, chemically induced binding, liquid



phase sintering partial melting, and full melting. As mentioned earlier, Levy's definition of DMLS was chosen for the focus of this study, and consequently only the LP partial melting binding mechanism will be discussed in detail (Dewidar M. M., 2002). LPS itself has "two technologies" distinguished by the type of binder used, namely that with a different binder, and that with no distinct binder (Dewidar M. M., 2002). DMLS would be classified under the latter technology as a fusing powder mixture process. Fusing powder mixtures are characterized by multiple phases that are partially molten. The author would encourage the reader to further examine the literature for detailed information on any of the other binding mechanisms

**Parameters and Densification:** Simchi provided a comprehensive study wherein six different metal powders were sintered and analysed to better understand the mechanisms of densification and the role of manufacturing parameters (Sateesh, 2014). Process parameters were defined as variables that control the laser sintering process, in contrast to material parameters, defined as: chemical constitutions and the purity of the material, method of alloying, and particle characteristics. Multiple parameters affect the final part density achieved using DMLS, and the corresponding microstructural features. Laser power, laser wavelength, laser spot size, laser scan rate, scan line spacing, powder layer thickness, scanning geometry, working atmosphere, and powder bed temperature are pertinent process parameters. In contrast, particle size, shape, and distribution are pertinent material parameters. Process parameters were varied, along with scan strategy and sintering atmosphere, and final part densities were recorded. The conclusions of the study were highly valuable to the continued research and improvement of DMLS, and are summarized as follows (Sateesh, 2014): Improved densification occurs with increased laser energy input to the powder until a certain saturation point. Chemistry, shape, and size of metal powder particles affect the densification of DMLS processes. Nitrogen sintering atmosphere yields less densification than argon sintering atmosphere. Dewidar found that for high-speed steel, part density increased with laser beam power, and decreased with increasing scan speed and space (Sateesh, 2014) This makes

sense because all three process parameter affect the amount of energy (the power density) delivered to the selected region of the powder bed. These results match further studies, specifically Simchi's study of densification of iron (Simchi, 2006), Tang's research on copper-based alloy (Simchi, 2006), Kruth's study of lasers and materials (Simchi, 2006), and Alkahari's study of consolidation characteristics of ferrous-based metal powder (Simchi, 2006). In addition, Tang found that particle shape (which affects the loose powder density) and binder mix fraction affect the final density of the sintered part (Simchi, 2006).

**Process Steps:** All DMLS parts start as concepts designed in a Computer Aided Design (CAD) software (Purtonen, 2014). The corresponding CAD file is then be exported in a printable form (.STL, .STEP) to the DMLS machine (Purtonen, 2014).

The DMLS machine then builds each layer as follows (Purtonen, 2014): The stage containing the metal powder is raised. The new layer of powder is spread across the old layer of powder via a spreading mechanism. The laser scans the powder bed to selectively sinter particles according to the current slice instructions dictated by the cad file. The build stage is lowered one layer thickness in preparation for receiving the fresh layer of powder. This process is repeated until the part is finished.

**Equipment's:** Though there are multiple DMLS machines on the market, a DMLS machine consists of the following components (Purtonen, 2014): a laser for selective irradiation of the metal powder, focusing optics for beam consolidation and maximum intensity of the laser beam, scanning mirrors to direct the beam to the desired powder bed location, a laser chiller unit for temperature control of the laser components, a motion control table for adding layers of material to the powder bed, a build cylinder for adding the new powder layer, spreader assembly for spreading and levelling the powder layer, an inert gas containment and delivery system for atmospheric gas control which prevents oxidation of particles, and finally a vacuum assembly for flushing the build chamber.

**Lasers:** There are mainly four kinds of lasers that are used in DMLS: Solid Fibre Lasers, Carbon Dioxide (CO<sub>2</sub>) lasers, Neodymium-Doped Yttrium Aluminium garnet (ND: YAG) lasers, and disk lasers. The ND: YAG laser has a wavelength of 1.06 $\mu$ m. The CO<sub>2</sub> laser was the most common laser used in commercial applications (including DMLS) with a wavelength of 10.6 $\mu$ m; however, it is now being replaced by fiber and disk lasers, which have shorter wavelengths (less than 2  $\mu$ m), and allow for faster build times. Selection of the laser type and wavelength should be based on the known absorption characteristics of the material (Manuf., 2007)

### **6.3. Parameters and Densification**

Simchi provided a comprehensive study wherein six different metal powders were sintered and analysed to better understand the mechanisms of densification and the role of manufacturing parameters.

Process parameters were defined as variables that control the laser sintering process, in contrast to material parameters, defined as: chemical constitutions and the purity of the material, method of alloying, and particle characteristics. Multiple parameters affect the final part density achieved using DMLS, and the corresponding microstructural features. Laser power, laser wavelength, laser spot size, laser scan rate, scan line spacing, powder layer thickness, scanning geometry, working atmosphere, and powder bed temperature are pertinent process parameters. In contrast, particle size, shape, and distribution are pertinent material parameters.

Process parameters were varied, along with scan strategy and sintering atmosphere, and final part densities were recorded. The conclusions of the study were highly valuable to the continued research and improvement of DMLS, and are summarized as follows: Improved densification occurs with increased laser energy input to the powder until a certain saturation point. Chemistry, shape, and size of metal powder particles affect the densification of DMLS processes. Nitrogen sintering atmosphere yields less densification than argon sintering atmosphere.

Dewidar found that for high-speed steel, part density increased with laser beam power, and decreased with increasing scan speed and space. This makes sense because all three process parameters affect the amount of energy (the power density) delivered to the selected region of the powder bed. These results match further studies, specifically Simchi's study of densification of iron, Tang's research on copper-based alloy, Krutch's study of lasers and materials, and Alkahari's study of consolidation characteristics of ferrous-based metal powder. In addition, Tang found that particle shape (which affects the loose powder density) and binder mix fraction affect the final density of the sintered part.

## **6.4 Process Steps**

All DMLS parts start as concepts designed in a Computer Aided Design (CAD) software. The corresponding CAD file is then exported in a printable form (.STL, .STEP) to the DMLS machine.

The DMLS machine then builds each layer as follows: The stage containing the metal powder is raised.

The new layer of powder is spread across the old layer of powder via a spreading mechanism. The laser scans the powder bed to selectively sinter particles according to the current slice instructions dictated by the CAD file. The build stage is lowered one layer thickness in preparation for receiving the fresh layer of powder. Though there are multiple DMLS machines on the market, a DMLS machine consists of the following components (Sateesh, 2014) laser for selective irradiation of the metal powder, focusing optics for beam consolidation and maximum intensity of the laser beam, scanning mirrors to direct the beam to the desired powder bed location, a laser chiller unit for temperature control of the laser components, a motion control table for adding layers of material to the powder bed, a build cylinder for adding the new powder layer, spreader assembly for spreading and levelling the powder layer, an inert gas containment and delivery system for atmospheric gas control which prevents oxidation of particles, and finally a vacuum assembly for flushing the build chamber.

**Lasers:** There are mainly four kinds of lasers that are used in DMLS: Solid Fiber Lasers, Carbon Dioxide (CO<sub>2</sub>) lasers, Neodymium-Doped Yttrium Aluminium garnet (ND: YAG) lasers, and disk lasers. The ND: YAG laser has a wavelength of 1.06μm. The CO<sub>2</sub> laser was the most common laser used in commercial applications(including DMLS) with a wavelength of 10.6μm; however, it is now being replaced by fibre and disk lasers, which have shorter wavelengths (less than 2 μm), and allow for faster build times. Selection of the laser type and wavelength should be based on the known absorption characteristics of the material

### **Rapid Prototyping**

Rapid prototyping is a group of techniques used to quickly fabricate a scale model of a physical part or assembly using three-dimensional computer aided design (CAD) data.

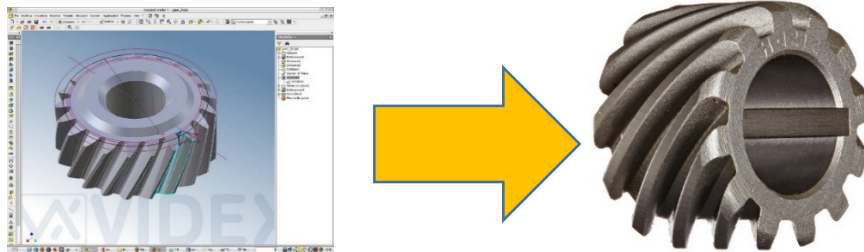

Figure 37 - CAD Model and Finished Part (<http://www.unite.com.pt/>, 2015)

### **Surface finish**

Surface finish, also known as surface texture or surface topography, is the nature of a surface as defined by the 3 characteristics of lay, surface roughness, and waviness. It comprises the small local deviations of a surface from the perfectly flat ideal (a true plane).

Roughness average ( $R_a$ ) is the arithmetic average of the absolute values of the roughness profile ordinates. Also known as Arithmetic Average (AA) and Center Line Average (CLA). The average roughness is the area between the roughness profile and its mean line, or the integral of the absolute value of the roughness profile height over the evaluation length.

Table 2 - All surface roughness is measured in Ra (roughness average) (Cerreta, Direct Metal Laser Sintering :An Overview, 2014)

<b>Material</b>	<b>Surface</b>	<b>Standard</b>	<b>Metric</b>
Aluminum (AlSi <sub>10</sub> Mg)	Horizontal	0.00024-0.00039"	6-10 μm
Aluminium (AlSi <sub>10</sub> Mg)	Vertical	0.00118-0.00157"	30-40 μm
Titanium (Ti64) Performance	Horizontal	0.00036-0.00047"	9-12 μm
Titanium (Ti64) Performance	Vertical	0.00160-0.00320"	40-80 μm
Titanium (Ti64) Speed	Horizontal	0.00023-0.00039"	6-10 μm
Titanium (Ti64) Speed	Vertical	0.00137-0.00157"	35-40 μm
Stainless (PH1)	Horizontal	0.00010-0.00020"	2.5-4.5 μm
Stainless (PH1)	Vertical	0.00060-0.00160"	15-40 μm
Maraging Steel (MS1)	Horizontal	0.00016-0.00025"	4-6.5 μm
Maraging Steel (MS1)	Vertical	0.00078-0.00195"	20-50 μm
Inconel (IN718)	Horizontal	0.00016-0.00025"	4-6 μm
Inconel (IN718)	Vertical	0.00078-0.00195"	20-50 μm

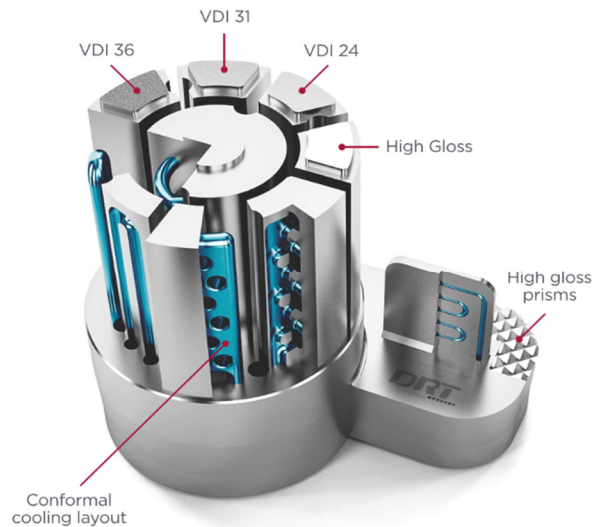
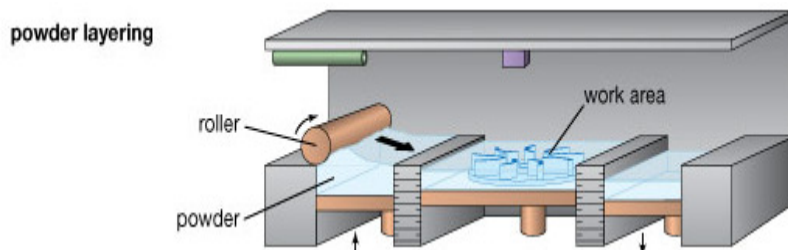

Figure 38 - Conformational cooling (<http://www.unite.com.pt/>, 2015)

## 6.5. Working principle

The basic principle of the Direct Metal Laser Sintering (DMLS) Technology is to melt down thin layers ( $20 \div 60 \mu\text{m}$ ) of Metal Powder with an electronically driven LASER beam (200W) • Layer by layer, it is possible to build any kind of shape and geometry, even those which are impossible to obtain with any other kind of technology. The accuracy is  $\pm 0,05\text{mm}$ . (Cerreta, Direct Metal Laser Sintering :An Overview, 2014).



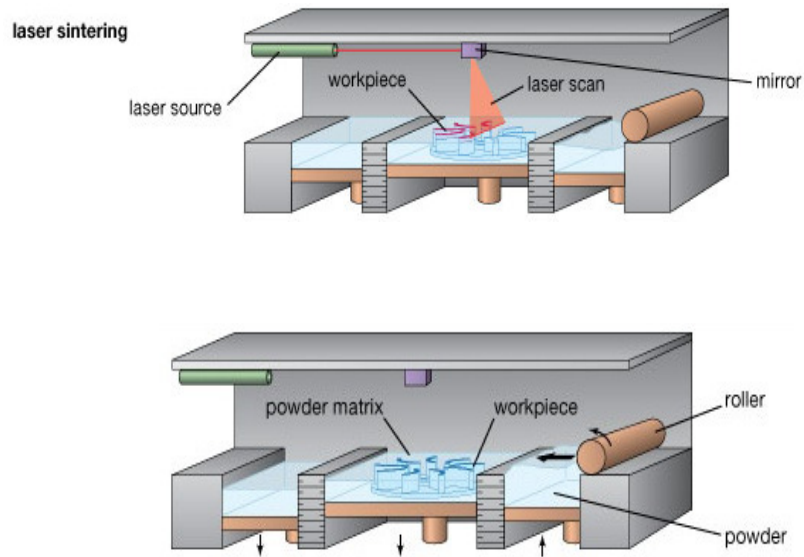

Figure 39 - Step by step procedure of DMLS (<http://www.unite.com.pt/>, 2015)

## 6.6. DMLS MACHINE

EOSINT M280 (4 off) – Metal Sintering Machine Effective

- Building volume (including building platform): 250mm x 250mm x 325mm Laser Type: Yb-fibre laser, 400 W
- Build speed (material-dependent): 2 – 8 mm<sup>3</sup>/slayer
- Thickness: 20 – 80 μm



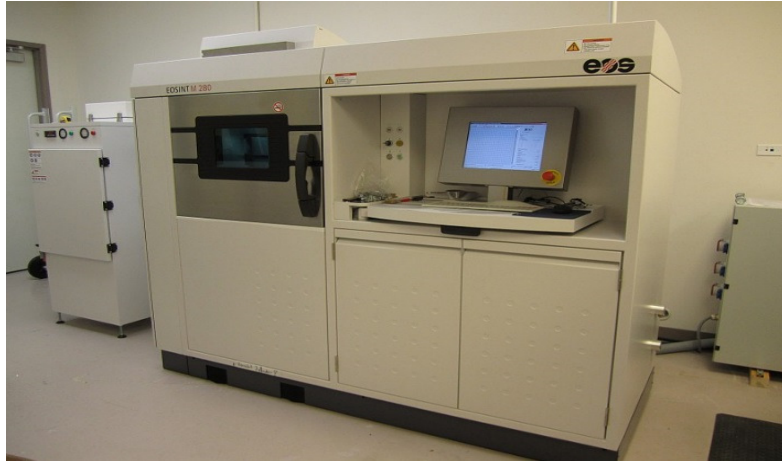
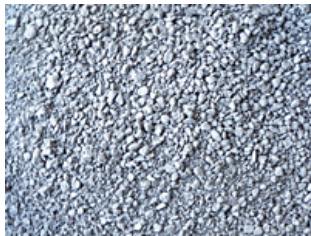

Figure 40 - Machine DMLS (<http://www.unite.com.pt/>, 2015)

### 6.6.1. Metal Powders Used (<http://www.unite.com.pt/>, 2015)

Currently available alloys used in the process include 17-4 and 15-5 stainless steel, maraging steel, cobalt chromium, Inconel 625 and Nickel alloy IW718, aluminium AISi10Mg, and titanium Ti-64

Stainless steel 17-4



Titanium Ti-64



Aluminium

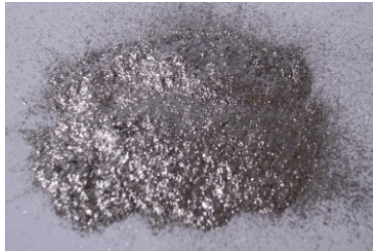

Nickel alloy IW 718



Figure 41 - Metal powder used in DMLS (<http://www.unite.com.pt/>, 2015)

## 6.7. Research Areas

Much research has taken place in DMLS since the mid 1990's, most likely being attributed to the release of the first commercial SLS machines (Mellor, 2014). The related works have covered a wide range of subjects involving DMLS, and can mainly be categorized into five topics: effects of DMLS parameters on outputs (Joseph W. Newkirk, 2015), specific DMLS applications and feasibility (Effects of Welding Parameters Onto Keyhole Geometry for Partial Penetration Laser Welding, 2015), (Additive Manufacturing of Al Alloys and Aluminium Matrix Composites (AMCs), 2014) DMLS simulation and modelling, investigation of equipment and process improvements to current DMLS systems, and DMLS behaviour of specific types of powders. For the purpose of this work, certain contemporary investigations have been considered most beneficial to DMLS theory and have been summarized. These summaries only represent a small portion of the breadth of works that have occurred in DMLS, and the author would encourage the reader to delve further into the literature contained in the reference section for more information.

**Top Surface Quality:** Yang investigated and defined top surface quality (TSQ) as the surface morphology contained in the xy plane (the surface parallel to the substrate) (Additive Manufacturing of Al Alloys and Aluminium Matrix Composites (AMCs), 2014). TSQ is important because every layer of powder is sintered on a previously

sintered layer of powder, except for the substrate. If the quality of the bonding between layers is not high, certain defects can occur such as: balling, war page, poor densification, and oxidation (Cerreta, Direct Metal Laser Sintering :An Overview, 2014). The study reported that defects could be avoided by maintaining top surface flatness, compactness, and cleanliness. Even further, the TSQ influencing factors were: surface status of the substrate, additive materials, structural powder morphology, scanning space, layer thickness, layer number, and balance of laser power and scanning speed (Cerreta, Direct Metal Laser Sintering :An Overview, 2014). The results verified that TSQ heavily influences overall final part qualities, and that its control is paramount for the output of high performance DMLS parts (Cerreta, Direct Metal Laser Sintering :An Overview, 2014).

**Consolidation Characteristics:** Another important publication reported on the consolidation characteristics of ferrous-based metal powder. It utilized a high speed camera with a telescoping lens to record sintering behaviour in the powder fusion zone (PFZ) (Dewidar M. M., 2002). Line consolidation was a term used to describe the consolidation of metal powders in the PFZ of a laser beam (Dewidar M. M., 2002). The line consolidation region was reported to have five distinct areas: the laser beam irradiated area, the PFZ, the liquid/melt pool area, the solidification area, and finally the powder free area. In addition, it was found that there are five types of line consolidation in DMLS of ferrous based powder, namely: continuous, discontinuous, ball-shaped, weak, and very little consolidation (Dewidar M. M., 2002). Poor consolidation will lead to a part with inferior mechanical properties because it will cause inhomogeneity in the three dimensional object's structure (Dewidar M. M., 2002).

**Post processing DMLS Parts:** As mentioned earlier, DMLS is based on a LPS partial melting binding mechanism. Because of this binding mechanism, surface roughness, porosity, residual stresses, and microstructural inhomogeneity exist in DMLS parts (Jialin Yang Institute of Machinery Manufacturing Technology, 2012). It has been widely known that shot peening and other post processing treatments can alleviate the previously mentioned items, and multiple

works have been carried out to see how post processing affects DMLS parts. Likewise, the focus of this study (Jialin Yang Institute of Machinery Manufacturing Technology, 2012) was the characterization of post processed samples created from three different DMLS powders. The resulting hardness and porosity, cross sectional micrographs, and surface residual stresses were recorded (Jialin Yang Institute of Machinery Manufacturing Technology, 2012). Analysis of the results led to the following conclusions: DMLS parts without post treatment have the above mentioned inconsistencies, parts that received shot peening showed homogenized surface residual stresses, and aging thermal treatment led to increased material hardness (Jialin Yang Institute of Machinery Manufacturing Technology, 2012).

## **6.8. Advantages and Limitations of DMLS**

The Advantages are:

- High speed: Because, no special tooling is required, parts can be built in a matter of hours.
- Complex geometries: Components can be designed with internal features and passages that cannot be cast or otherwise machined.
- High quality: DMLS creates parts with high accuracy and detailed resolution.

### **6.8.1. Applications**

Rapid tooling and rapid prototyping were the main commercial applications for DMLS in its initial years in the market. There is a strong and growing interest in what is known as “rapid manufacturing”, which is the use of DMLS to create end-use parts. Multiple industries are using DMLS for the previously mentioned application because of the benefits of the technology such as material cost savings and low production run capability. The aerospace industry utilizes DMLS to fabricate end use parts (landing gears and titanium components) because of the very high cost savings in comparison with traditional manufacturing methods. In the auto-industry, DMLS is used to create custom high performance metal parts (for formula one). One such example was the use of DMLS for

fabrication of a race car gear box which weighed 30% less than a traditionally manufactured gearbox. In the medical field, titanium alloy dental implants are now being manufactured via DMLS due to the economic advantage over traditional manufacturing. Likewise, bone reconstruction surgeons utilize DMLS to create implants such as craniofacial or orthopaedic implants.

### **Medical field**

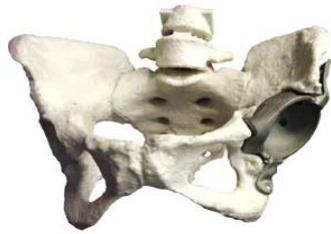

### **Aerospace**



### **Automotive**



### **Metal 3D Printing**



### **Grippers**



### **Gauges**



Figure 42 - Parts produced from DMLS (<http://www.unite.com.pt/>, 2015).

### 6.8.2. Limitations

- Surfaces need to be polished.
- Removing metal support structures and thermal post-processing is time consuming (you can't have the supports in a different material than the part)

### 6.9 Case study: Feasibility Study on Cooling

Parts made in a plastic injection moulding process can have their own unique set of possible defects. The following is the one of the most common defects associated with the plastic injection process is cooling. By the additive manufacturing technique the cooling is increased and the time is decreased by the 43%, in the above scale the time required for cooling in the conventional process is 42.508seconds.

Where as in the additive manufacturing the time required in the conformal cooling system is 25.339s.

By the DMLS 43% of time is reduced in cooling.

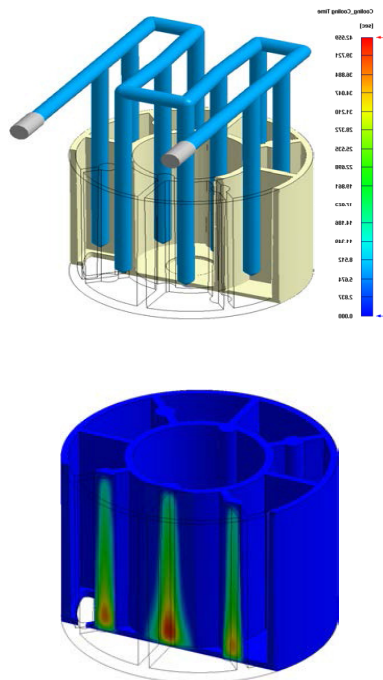

Figure 43 - Conventional cooling (<http://www.unite.com.pt/>, 2015)

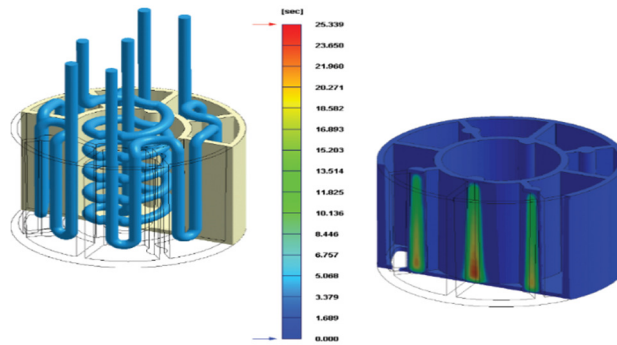

Figure 44 - Conformal cooling (<http://www.unite.com.pt/>, 2015)

There has been a lot of talk among molders and mold makers of late about conformal cooling. Why? Because it's an industry game changer. Conventional molds have straight-line cooling channels. Simply put, conformal cooling makes use of cooling lines in an injection mold that curve and closely follow the geometry of the part to be produced. There are a variety of methods for manufacturing a conformally cooled mold, that includes laser sintering.

If conformal cooling is implemented with little or no engineering analysis, you can expect to get a 10% reduction in injection mold cycle time. However, by performing more engineering analysis—such as flow analysis, computational fluid dynamics (CFD), and finite-element analysis (FEA)—a better quality mold and more cycle reduction can be achieved.

A typical cycle-time reduction range for a properly engineered, conformally cooled mold is 20% to 40%. If little or no engineering analysis is done, you risk premature mold failure or lack of performance because of poor design elements or incorrect assumptions that were not identified and corrected before mold manufacture.

## **7. Pros and Cons of Additive and Subtractive Technology**

As companies start to reassess their manufacturing strategy, and the development of micro-manufacturing hubs increase as part of the new industrial revolution, one thing is certain, demand will continue to rise for new technology that provides a better, faster, cheaper way of getting product to market. The solution to meet the changing needs of designers, engineers and manufacturers will be a combination of new, more flexible rapid prototyping and manufacturing machines employing either additive or subtractive methods. Additive and subtractive technologies allow companies to innovate product design, business models and manufacturing processes. By bringing the RP&M solution in-house, companies, manufacturers and micro-manufacturing hubs gain shorter design iterations and data security, and reduce prototyping and manufacturing costs. The decision to invest in technology should be based on the end-part material required for prototypes and manufactured parts, and how the technology can fit into a company workflow.

Emerging technologies are having a dramatic effect on the manufacturing industry. One of the most important of these is additive manufacturing, often referred to as DMLS.

DMLS printing allows for the production of parts with complexity that can't be matched by traditional manufacturing methods. It can be used to produce impossible-to-machine features, like parts without seams or joints. Complex geometric or organic shapes are often only possible to produce using additive manufacturing methods, as is true for hollow parts.

Other advantages to additive manufacturing methods:

- A part can be produced in much less time using additive manufacturing than using the traditional subtractive manufacturing methods.
- The more complex (less solid) a part is, the faster and less expensive it is to produce.



- Anything that can be designed in a CAD program can be printed with additive manufacturing.
- Parts used for fit checks, presentation models and short-term use can best be made with additive manufacturing.

There are some drawbacks to additive manufacturing that, in some instances, make subtractive manufacturing the better choice. For example, when it comes to precision for common functional features, like flat faces, drilled and tapped holes, counterbores, and mating components, subtractive methods will generally produce results with the highest repeatability and dimensional accuracy.

Other advantages to subtractive manufacturing methods:

- Subtractive manufacturing produces lower, more capable tolerances than additive manufacturing.
- Subtractive methods result in smoother surfaces than additive methods.

Additive manufacturing creates micro-pores, which can lead to infection in medical uses and also add fatigue points that can lead to stress fractures with heavy loads.

- Parts intended for long-term use or high-stress use are best made with subtractive manufacturing.
- Medical and aerospace industries prefer subtractive for parts required to stay in the body for long periods of time and for flight-critical aerospace functions.

## **8. Conclusion and future work**

The completion of this Internship proved to be essential to my training, both personally and professionally. I managed to connect most of the theoretical knowledge that I acquired as a student of this course and were of tremendous help throughout this 9 month internship.

I realized that teamwork is fundamental for everything to work well, as well as coordination and know how to manage the work in general and of each. Able to manage small internal conflicts makes the company to be functional in its entire entirety. Internship in this company is so great a closeness to the world of moulds makes realized the practice of what I had learned in theory in these course I attended.

In my view, mould companies will have a great importance in the future, as more will be needed to achieve moulded parts evolve and modernize the world in any of the industries.as the pieces to mould increasingly tend to be larger and more complex technologies will follow, both in the sector of the drawing, as in use to inject material, among others.

This Internship proved to be very diverse and nothing monotonous because every day there was something new to do and learn. I performed many important tasks not only for the proper functioning of a mould, but also for the proper functioning of the company.

Over the nine months of training I learned a lot. For me, dealing daily with the same cast, to add parts and more parts, doing tests and more tests, it was gratifying to see their growth and all that was done, especially when tested in the injection machine, where I could see the plastic parts with the desired shape.

The moulds sector is a sector that increasingly is being spoken and which occupies an increasingly prominent place.

DMLS is considered an advanced manufacturing method and is being adopted by a wide range of industries that need any single use or combination of uses for rapid tooling, rapid manufacturing, and rapid prototyping. The survey of the literature on the subject has led the

author to conclude that there are five areas that future research will focus on: DMLS process mappings (including parameters) for different powders, equipment and process modifications for increased efficiency (in terms of productivity and economy), application feasibility investigations, simulation and modelling, and sintered part surface quality. Current barriers for DMLS include equipment cost, sintered part surface quality, and build time. As with any relatively new technology, cost is very high in comparison to when it becomes main stream. It will definitely come down as DMLS usage increases

In these Internship I also worked at Bench and Injection, in this report I mentioned the work I performed in these area in the **Annexes**.

## 9. References

- (2015). Retrieved from DRT Moldes: <http://www.drtmoldes.com/>
- *Additive Manufacturing of Al Alloys and Aluminium Matrix Composites (AMCs)*. (2014).
- Bewilogua, K., Brauer, G., Dietz, A., Gabler, J., Goch, G., Karpuschewski, B., & Szyszka, B. (2009, 1). *Surface Technology for automotive engineering*. p. 627.
- Cerreta, P. (2004). *EML 6933 Advanced materials and processes*. America.
- Cerreta, P. (2014). *Direct Metal Laser Sintering :An Overview*. p. 8.
- *CustomPart.net*. (2007). Retrieved from <http://www.custompartnet.com/wu/InjectionMolding>
- Dewidar, M. M. (2002). *Direct and Indirect Laser Sintering of Metals*. uk.
- Dewidar, M. M. (2002). *Direct and Indirect Laser Sintering of Metals*.
- *DRT Moldes*. (2012, 6). Retrieved from <http://www.drtmoldes.com/>
- *Effects of Welding Parameters Onto Keyhole Geometry for Partial Penetration Laser Welding*. (2015).
- <http://www.protolabs.co.uk/additive-manufacturing>. (n.d.). Retrieved from proto labs.
- <http://www.unite.com.pt/>. (2015). Retrieved from Unite: <http://www.unite.com.pt/>
- Jialin Yang Institute of Machinery Manufacturing Technology, C. A. (2012). *Rapid Prototyping*.
- Joseph W. Newkirk, F. M. (2015). *ASM International Handbook Committee*.

- Manuf., S. J. (2007). Analytical Modeling of Chatter Stability in Turning and Boring Operations. *Analytical Modeling of Chatter Stability in Turning and Boring Operations*, 7.
- Mattson, M. (2010). CNC programming : principles and applications. In M. Mattson, *CNC programming : principles and applications*. Clifton Park : Delmar, Cengage Learning.
- Mellor, S. (2014). Additive manufacturing: A framework for implementation. 194-201.
- Nanfara, F., Uccello, T., & Murphy, D. (1995). The CNC Workbook: An Introduction to Computer Numerical Control. In F. Nanfara, T. Uccello, & D. Murphy, *The CNC Workbook: An Introduction to Computer Numerical Control*. Prentice Hall,.
- Purtonen, T. (2014). Monitoring and Adaptive Control of Laser Processes. *8th International Conference on Laser Assisted Net Shape Engineering LANE 2014*, 1218-1231.
- Sateesh. (2014). Microstructure and Mechanical Characterization of Laser Sintered Inconel-625 Superalloy. 779.
- Simchi, A. (2006). Direct laser sintering of metal powders: Mechanism, kinetics and microstructural features. pp. 148-158.
- Systems, E. G. (2004, 9 21-24). DMLS – DEVELOPMENT HISTORY AND. p. 12.
- Thyer, G. E. (1988). Computer numerical control of machine tools. In G. E. Thyer, *Computer numerical control of machine tools*. Heinemann Professional.

## **Annexes**

## ANNEX 1: The Work done by me in DRT in Bench

Bench is the most important phase of mold making process. I was asked to observe the work process in the Bench for almost 3 months so as to gain knowledge about different types of components and the various adjustment techniques used by them in order to have good quality part. Injection moulding moulds and high pressure die casting dies are fabricated to a standard mould set. The standard mould set consists of two clamp plates, two cavity plates, guiding elements between them, an optional back plate, two risers and an ejector set. Ejector set consists of an ejector base plate, an ejector retaining plate and an optional set of buffer plates. Guiding elements are guide pillars, guide sleeves and centring sleeves in each corner of the mould.

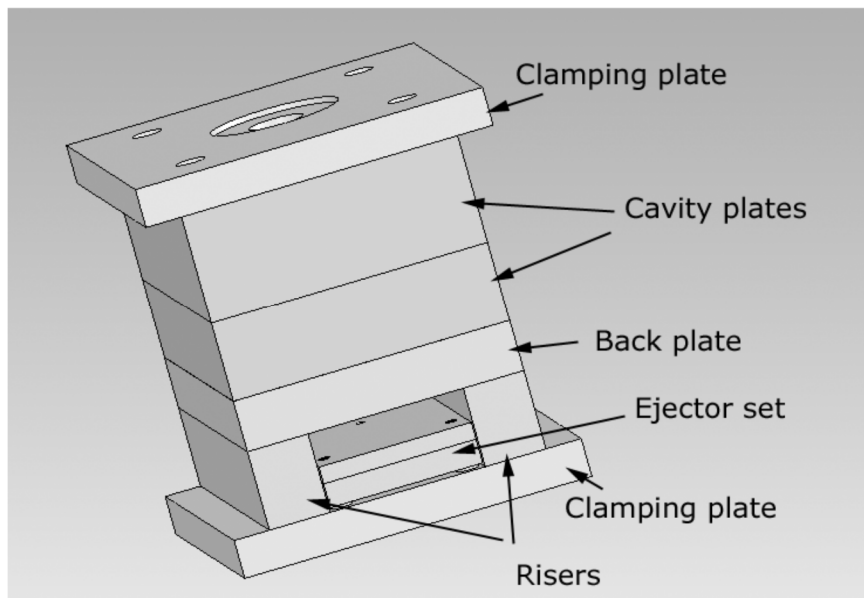

Components in a Standard Mould (DRT Moldes, 2012)

The standard mould is the most simple design ,basically the standard mould ,is same as two plate moulds construction, they divided in two side: cavity side and core side ,cavity side is the side that construct to

flowing plastic material from nozzle to cavity parts ,basically they consist of sprue, runner

Injection moulding moulds and high pressure die casting dies are fabricated to a standard mould set. The standard mould set consists of two clamp plates, two cavity plates, guiding elements between them, an optional back plate, two risers and an ejector set. Ejector set consists of an ejector base plate, an ejector retaining plate and an optional set of buffer plates. Guiding elements are guide pillars, guide sleeves and centring sleeves in each corner of the mould.

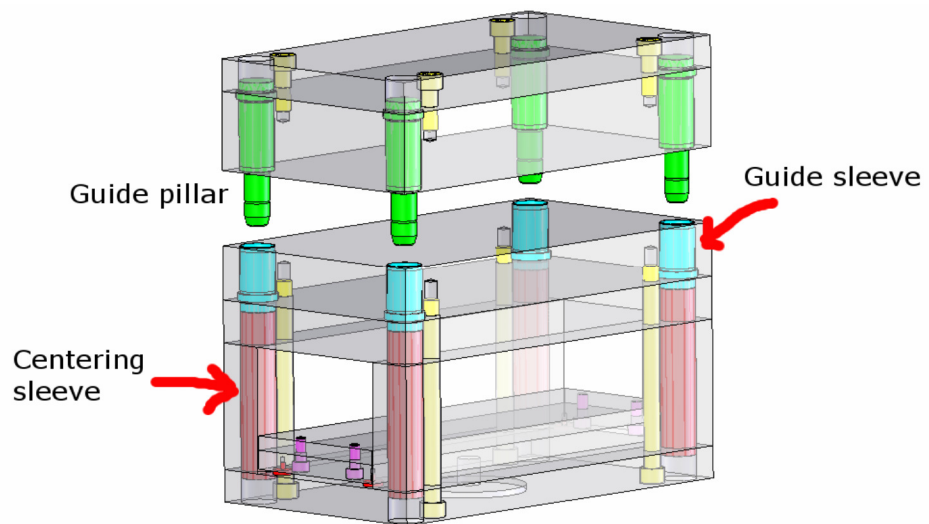

Guide elements (DRT Moldes, 2012)

Mould is divided into two halves: fixed and movable half. Movable half consists of one clamping plate, the ejector set, risers and one cavity plate. The fixed half consists of one clamping plate. Guide pillars and guide sleeves lock the two halves together in vertical and horizontal directions. High pressure die casting and injection moulding machines have a mould closing mechanism, which press the mould halves tightly together

The basic functional parts in a HPDC die or injection molding are:

Cavity and cores (fixed and moving cores), which give the shape to the casting or molding



Runner system, which leads the molten raw material from the machine injection / shot system to the cavities

Core moving mechanisms, which will move the movable cores in in the beginning of the machine cycle and out along with the mold/die opening

Ejecting mechanism, which removes the part from the cavity together with the machine ejection system

Cooling/tempering channels, which keep the thermal balance during molding or casting operations

The mold/die functional parts act together with the casting/molding machine. In the machine there are parts for dosing the raw material into the mold/die, parts for producing the core moving forces (electrical, hydraulic or pneumatic), parts for producing the forces for ejection (electrical or hydraulic) and parts for circulating the cooling liquid inside the mold cooling/tempering channels. The system for circulating the cooling liquid may also be separate equipment's like HPDC tempering devices.

The space inside the mold in which the part is shaped is called a mould cavity. The surface between the fixed and movable halves is called a parting surface. As the first choice the parting surface should be planar like in the image below. Only if it is absolutely necessary to make stepped or shaped parting surface, this option could be taken into consideration. The two mould halves need to fit tightly together. Otherwise the high pressure inside the mould cavity during molding operation (or casting shot) will extrude the molding material to the parting surface. It is more difficult to produce surface flatness to shaped or stepped surfaces than to planar surfaces.

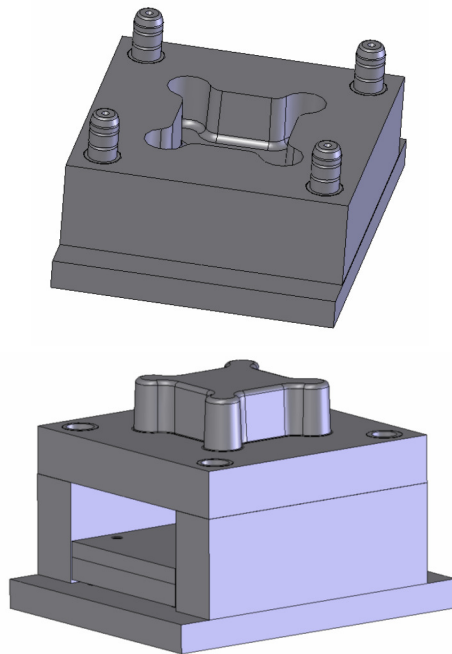

Left: Mould fixed side with the cavity. The space, inside which the part is shaped, is also called a cavity. Right: Mould movable side with a core. The surface between these mould halves is called a parting surface. (DRT Moldes, 2012)

Core side construct to make shape for core, demoulding system and ejection system, at this side we design ejection system Standard mould have one parting line, and have an opening direction .this type of mould use in all kinds of plastic parts that doesn't have undercut, inner and outer screw

A steel device to mould a moulding material into a certain shape. The section that is engaged in opening / closing movement is called a core plate, and the section that is not is called a cavity plate. Generally, the front side of a part is a cavity plate and the rear side is a core plate. The core plate leaves a trace on a part, because it has an ejector pin to push the part. The cavity plate has a sprue bush, which is the entrance for molten plastic.

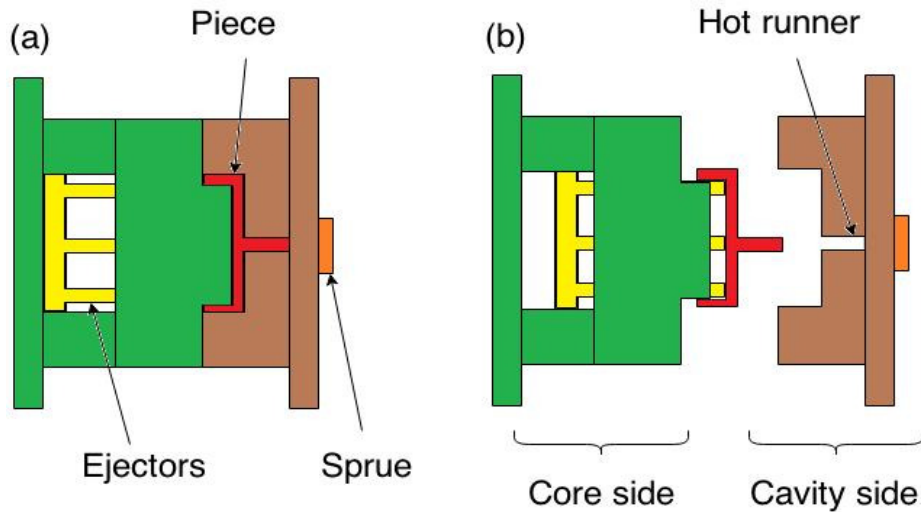

Hot runner (DRT Moldes, 2012)

Injection moulding ejector set is fixed to the moulding machine with one element in the centre of the mould. Without guides, the ejector pins are sole elements, which support these plates along with the fixture. Compared to the ejection pins strength and stiffness, the ejector set produces a relatively high load. Even the smallest imbalance will bend and in the worst case break the pins. High pressure die casting die ejector set is fixed to the casting machine with four ejection bars. Four bars give rather good support, but it is still possible that the ejector set bends - for example if the part sticks to the die cavity from one side or there is some other kind of imbalance in the ejection. Usually the high pressure die casting machine ejector mechanism works with hydraulic cylinders. It returns the die ejector set to the back position with a cylinder backward movement. In some injection moulding machine types the ejector mechanism is returned with the mechanism backward movement. In some machines the returning movement is done with a spring in the fixture. High pressure die casting hydraulic cylinders typically produce also the backward movement. In any of these cases it is recommended to place four ejector set returning pins to mechanically return the ejection system to the initial position. The set of returning pins is also the lightest guiding construction. Returning pins are thick ejector pins, which are placed outside the cavity and extended to the mould parting surface.

If the ejector set returning system does not work properly, these pins secure the ejector set to the initial position.

### **The Work done by me in DRT in Bench**

After the reeds all placed it is the turn of proceeding with placing plugs to cover the holes of the waters that were made to create the ways of water channels but they had to be covered so that the channel only has one input and one output. For it proceeded will place caps with  $\frac{1}{4}$  measures "  $\frac{1}{2}$  ",  $\frac{1}{8}$  " and  $\frac{3}{8}$  " that are already ordered according to the measures. These caps are screwed but first take a little glue which causes the cap skirt and does not seal as well.



Bushing Channels sealed (DRT Moldes, 2012)



Caps (DRT Moldes, 2012)

It was used red lead inside the plate bushing and wants to seek a bridge to fit the sleeve before Inserting on the plate bushing. By placing the

bushing on the plate bushing is repaired which was not fully adjusted. And then with the help of the bridge, the sleeve was high, taking the beat red Ink transferring to another plate lean, so the sites where it appears painted is where fair. Where there appears painted is because not touched the face.



Red lead (DRT Moldes, 2012)

And then after making some minor adjustments where it got a few hundredths or less so in the area of the corners and then proceeded placement will once again bushing in place and this time perfectly fitted with copper's help. Copper is used to hit the steel because copper material is softer then steel, thereby not spoiling the steel but the resulting force is high.



Copper (DRT Moldes, 2012)

Then again adjust the sleeve in place. As this mould was about halfway through its construction, only managed to keep part of what is done in the bush because the rest was done. It was then that proceeds from placement of balances already set in place and extractors. Then it was all connected to the sheet of the extractors that was ready to links the pieces of balances already in place.

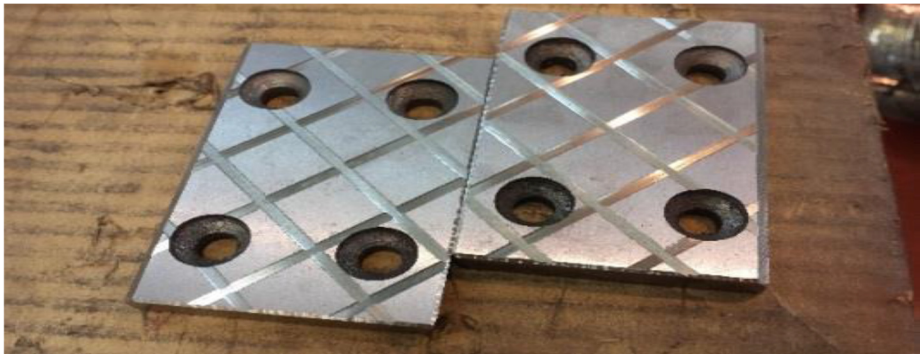

Slide wear plates (DRT Moldes, 2012)

While all this going on tight tears in the sheets slide and through the manual grinder with a millstone of 4 mm. The tear was deep about 3/10. Then these are marked with wedges with numbers and were also marked in the steel where they would put.



Sliding bars (DRT Moldes, 2012)

These sheets were sent to carry nitriding treatment involving the introduction of nitrogen in the form of iron nitrides which provides them with a substantially higher strength and prevents the moving element. After reaching the treatment they were placed on site and the tight plates with conical screws and punched with machine screws. Then was put quite thick, thick oil itself on the plates slip so that the variable component not flu. After all well-oiled, it tested the mobile element that worked well with no gaps. At the edge of the variable component was also necessary to resort to the red lead to see if it was just the tip of the moving element is mordant area and could not have failures. The movement of the movable element was done through a guide mechanically pushing the mobile element to the right place while the mould closed. Then, having been assembled plate bushing with the plate of extractors and extractors of clamping plate was time to take the test to see if there was water leakage in the mould.

### **Hot runner moulding system**

Thus a machine was connected via two hoses, one for input and one for output. The water is set at an initial pressure of 3 bar and the flow rate and had leaks were recorded, then it was put to 5 bar and the machine was turned off. If looked at for a gauge to whether the lowered pressure which meant that there would be an escape.

Every plastic part starts in a mould. Moulds are classified into two main types, cold runner and hot runner. Each has its advantages and disadvantages. Your plastic injection moulded will be able to give you the costs and benefits of using these different systems. However, by understanding the key differences of these technologies, you can have a more educated discussion on the type of mould that would best fit your project. First, let's discuss cold runner moulding systems Cold runner moulds usually consist of 2 or 3 plates that are held within the mould base. The plastic is injected into the mould via the sprue and fills the runners which lead to the parts in the cavity. In 2 plate moulds, the runner system and parts are attached, and an ejection system is used to separate the pair from the mould. For those of you who

assembled a model car at some point in your youth, the runners and the parts were not separated. The child assembling the model was responsible for that final part of the process. In 3 plate moulds, the runner is contained on a separate plate, leaving the parts to be ejected alone. In both systems, the runner is recycled and reground, reducing plastic waste. However, these processes can increase cycle time

Hot runner moulds consist of 2 plates that are heated with a manifold system. The manifold sends the melted plastic to nozzles which fill the part cavities. There are several types of hot runner systems, however, in general, they fall into two main categories; externally heated and internally heated. The externally heated systems are well suited to polymers that are sensitive to thermal variations. Internally heated systems offer better flow control.

The hot runner process eliminates runners entirely, so recycling and grind (which can only be done with virgin plastics) do not impact cycle times. A variation of this system is called an insulated runner. The insulation, rather than heat, keeps the plastic in a molten state. This system can only accommodate a few types of plastics, specifically semi-crystalline polymers which have a low thermal conductivity.



Water Leakage Test (DRT Moldes, 2012)





Then the portion of the cavity that was already finished was attached to part of the chuck and the foot was placed in the mould which had previously been dyed orange. Then the mould was closed and clean and transported to the injection site so that it proceeds to the test.

If the test in the injection was good, and I could see that the pieces were to come out as desired. In making observation of these pieces I noticed still quite noticed the lines left by the cutters in the machining but that overall the piece was doing well.

Then these parts are observed more carefully and are made a report to know what they have to do so that the mould be well and that these parts do well. After the report will get proceeded to the mould opening of moulded area both in the cavity as in chuck. This experiment was very tiring because I had about two days, only 16 hours at a polishing moulded part of this zone of the bushing mould. Then it was verified by the gentleman who accompanied me was missing a part in eroded once again was named the chief bench who agreed and called the programmer to the electrodes that mould was then solve what happened.

Then the employee who was decided to start work another mould and it was with this template, the number 749 who got to know the process from the beginning. This mould is to mirror a well-known brand in the automotive world. So I could see the injection clamping plates, the plate of the wells, the plate bushings, shims, and the sheet of the extractors, the clamping plate of the extractor and the extraction clamping plate when they are not connected and in form simpler. First was connected via machine screws and then adjusted the cavity, which was first treated by putting fins and channels covering water, the plate of wells and then the wells of the plate to the clamping plate of the injection, even without bringing the nozzle in site. Then the extraction is screwed clamping plate shims, and then the support pillars because the mould does not bend when



Mould Pillars (DRT Moldes, 2012)

The next step is to treat part of the bushing as done for the other mould set as straws, post buffers, etc. The plates slide and have been torn through the grinder and then were sent for treatment but rather were marked with numbers. When they arrived they were placed in the right place and tight. Then put up the sleeve in place, i.e. the plate bushing that has been first adjusted through the use of red lead and where adjustments could be made to enter fair. After the balances are adjusted and extractor with the use of red lead to failures were checked after which it was fixed. It was put red lead and finding as if the extractor had to close.



Balance adjustment (DRT Moldes, 2012)

When it was found that everything was perfectly done going to fit another extractor / balance. After all the adjustments it was time to use lubricant in and slide plate and test to see if the furniture elements worked well. This took place, but did not close properly because something was encounter its path. The two mobile elements had to be marked with red lead and adjusted in order to run the whole course to join steel with steel, so there is no slack.



Mobile elements (DRT Moldes, 2012)

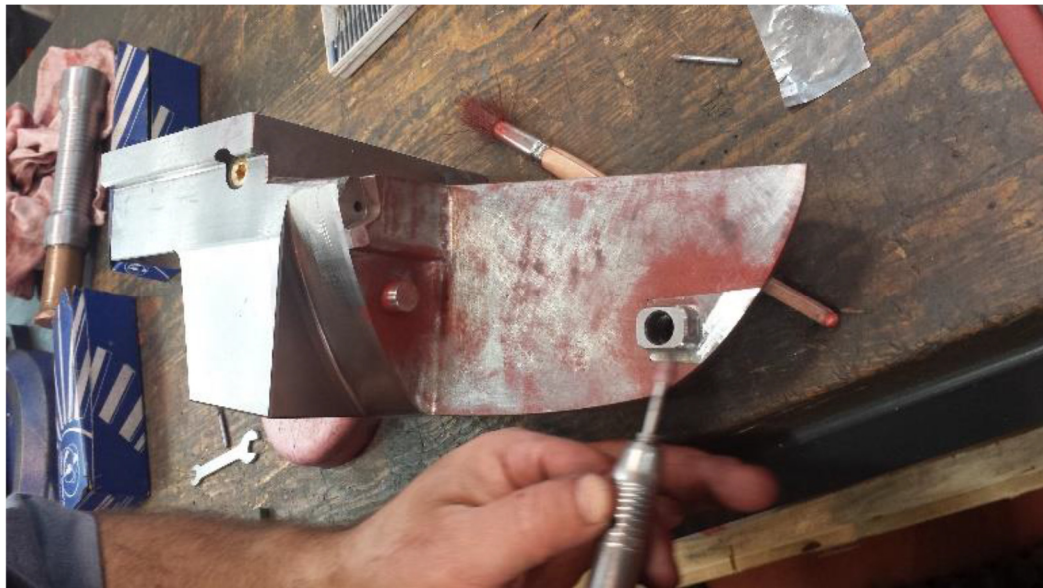

Steel Removal in Mobile Element (DRT Moldes, 2012)

Then it was prepared plate of extractors with the slide bar of balances. These were connected to the water channels it balances the water will also pass to cool the mould and thus also the plastic part. Then, it was made the extractor plate extractors

connection with the clamping plate thus connecting rods balances with the slide plates there by, but before the recores were put into the water on the plate and bushings of the cavity. The balances are used for parts can be injected with negative areas and that after opening the mould they go away first before the mould opening, not enough from the piece which has been shaped.



Balances (DRT Moldes, 2012)



Balances (DRT Moldes, 2012)

Next, the connection was made by extraction of the clamping plate with shims were placed and the support pillars. One water test was done and the registered flow rate

in each channel. After the mobile element has been tested and since there were the adjustments were already all made was time to assemble the structure which would bring the hydraulic cylinders. This structure was assembled and then bolted with the cylinder more below.

But before you attach the cylinder was made a test of whether the cylinder was working, it was then blown with air into the holes.

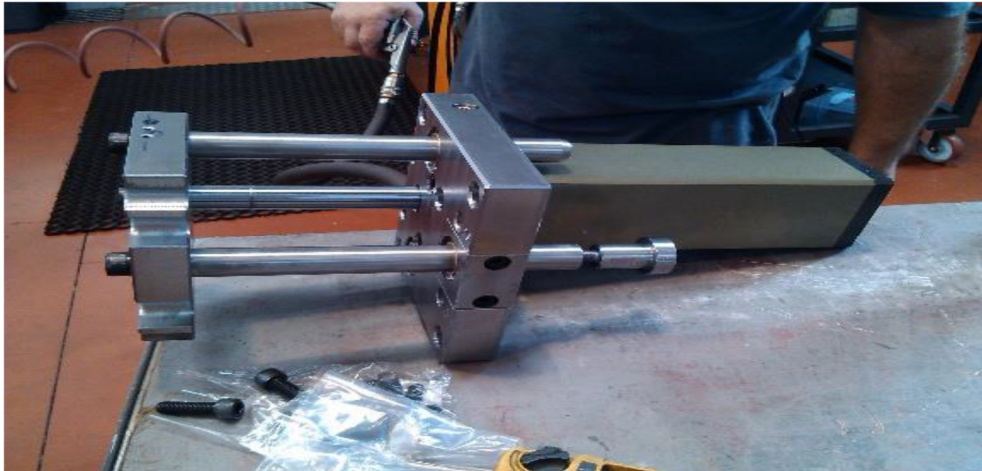

Hydraulic open structure (DRT Moldes, 2012)

After all mounted proceeded to measurement will know the feet of pipe that had to cut then proceeding with spiking in these recoros pipes for the oil. A machine to carry out the crimping was used.

At the end of all mounted oil pipe was to seek an oil pressure machine to test whether all was well connected and working. The test was positive, everything was working well.



Crimping machine (DRT Moldes, 2012)



Hydraulic oil Test (DRT Moldes, 2012)

Then it was decided to have the mount before had prepared, the shims with the fixed pillars in the extraction clamping plate and everything was bolted plate will bushings. Part of the bushings was lying and was made a test to see if the extractors were functioning well, so were linked chains of a bridge plates pulled up, all found to be working well.



Extractor Test (DRT Moldes, 2012)

Then the mould was closed but first painted in the area of the cavity with red lead to the beat to know that part rings and remove material. They have a technique is to close the mould, put the copper with about 60mm thickness and suddenly take on, causing the weight cavity of the bushing hitting thus simulating the force when closing the mould. They use this technique because there is only a press and this is complicated serve everyone. Then proceeded to paint the feet of mould on orange colour and are placed at the site.



Risers (DRT Moldes, 2012)

The moulded area of the sleeve and the cavity are polished to have a good finish. And after having everything in place, the mould is transported to the foot of the injection site. I could be there when this mould was tested and loved the same experience. The hydraulics worked well and balances also did their job well. The day after this experiment was transferred to another section.



## 4.5 Case study on Variotherm

The polymer injection products produced by using the current injection moulding method usually have many defects, such as short shot, jetting, sink mark, flow mark, weld mark, and floating fibers. These defects have to be eliminated by using post-processing processes such as spraying and coating, which will cause environment pollution and waste in time, materials, energy and labor. These problems can be solved effectively by using a new injection method, named as variotherm injection molding or rapid heat cycle molding (RHCM), a new type of dynamic mold temperature control system using steam as heating medium and cooling water as coolant was developed for variotherm injection molding. The injection mold is heated to a temperature higher than the glass transition temperature of the resin, and keeps this temperature in the polymer melt filling stage. To evaluate the efficiency of steam heating and coolant cooling, the mold surface temperature response during the heating stage and the polymer melt temperature response during the cooling stage were investigated by numerical thermal analysis. During heating, the mold surface temperature can be raised up rapidly with an average heating speed of  $5.4^{\circ}\text{C}/\text{s}$  and finally reaches an equilibrium temperature after an effective heating time of 40 s. It takes about 34.5 s to cool down the shaped polymer melt to the ejection temperature for demoulding. The effect of main parameters such as mold structure, material of mold insert on heating/cooling efficiency and surface temperature uniformity

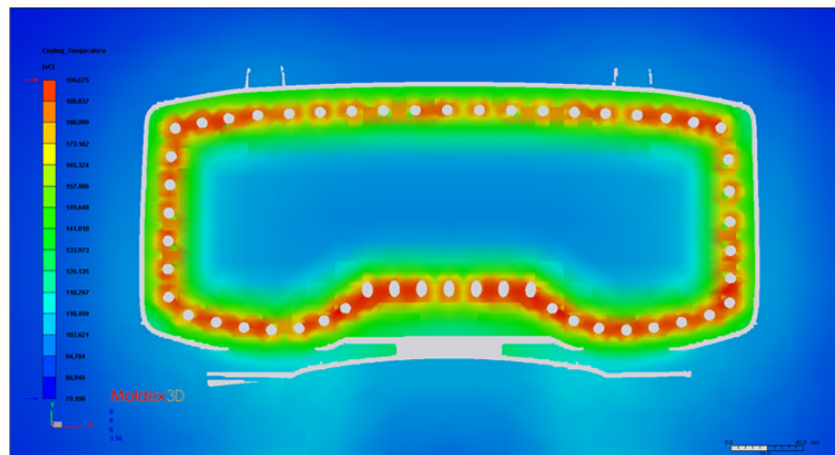

Temperature distribution around the weldline location at the end of filling for RHCM (DRT Moldes, 2012)

Figure-i shows the temperature distribution of moldbase at the end of filling in Conventional Injection Molding (CIM). The high temperature region is located in the center of moldbase with highest temperature of  $106^{\circ}\text{C}$ . Figure-ii shows the temperature distribution of moldbase during filling phase in Rapid Heat Cycle Molding (RHCM). Obviously, the high temperature region is located around steam channel during filling phase. Figure-iii shows the temperature distribution of

moldbase in filling phase in Induction Heating Molding (IHM) process. Since the heating method is via the mold surface using electrical power, the high temperature region is located on the surface of cavity side at the beginning of filling. Also, at the end of filling, the temperature is cooled down. Finally, Figure-iii shows the temperature distribution of moldbase during filling phase in E-mold process. A high temperature region occurs around the heater when using the electrical heating. Furthermore, the usage benefits of high mold temperature for the quality improvement of injection parts can be verified via the temperature distribution around the weldline location as shown in Figure-iv and Table-i. Apparently, the application of variotherm technologies, including RHCM, IHM, and E-mold, makes the surface temperature raised up at the end of Filling. The strength of the weldline is therefore enhanced.

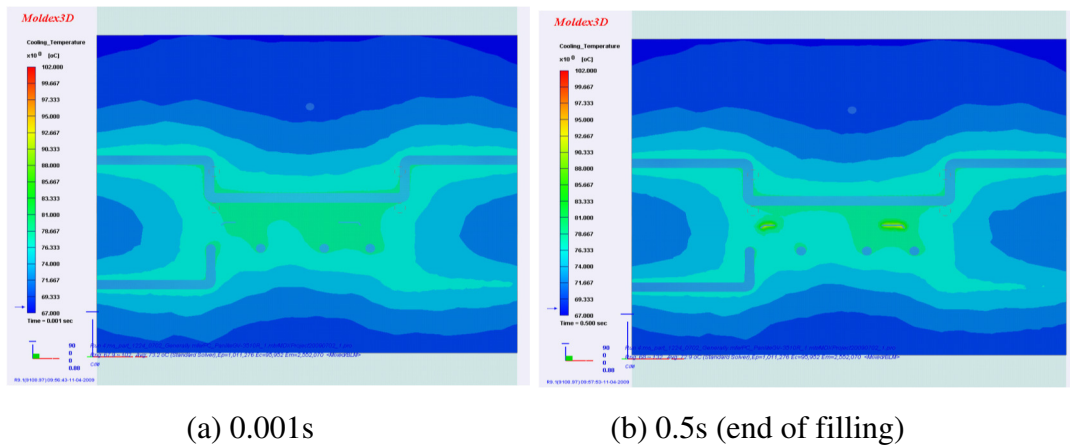

Figure-i- Temperature distribution of moldbase during filling phase in CIM process. (DRT Moldes, 2012)

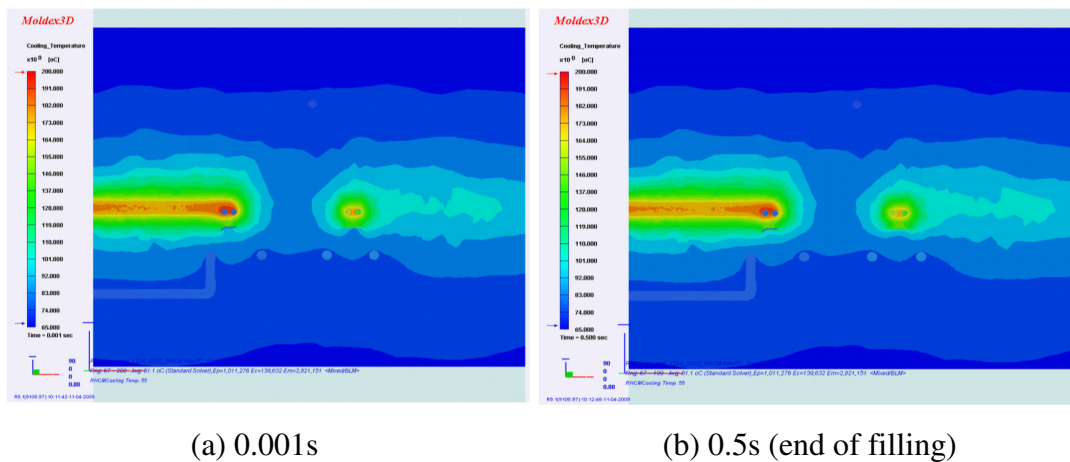
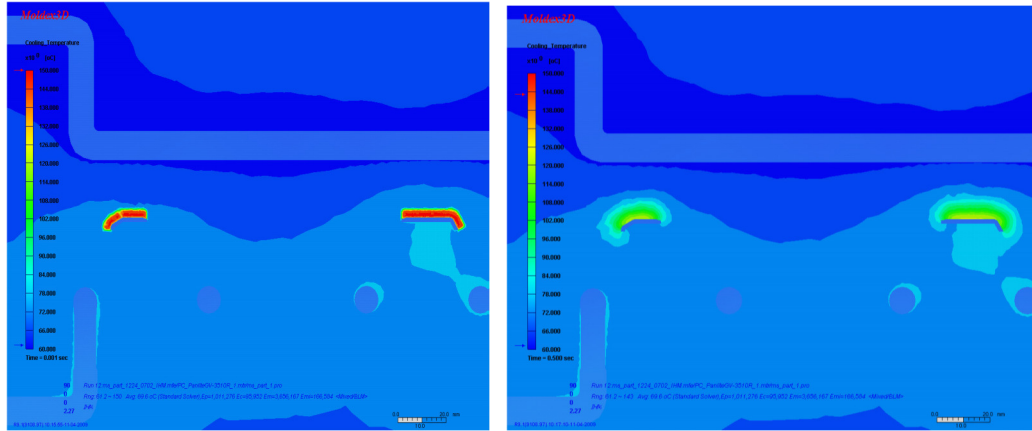

Figure-ii- Temperature distribution of moldbase during filling phase in RHCM process (DRT Moldes, 2012)



(a) 0.001s

(b) 0.5s (end of filling)

Figure-iii- Temperature distribution of moldbase during filling phase in IHM process (DRT Moldes, 2012)

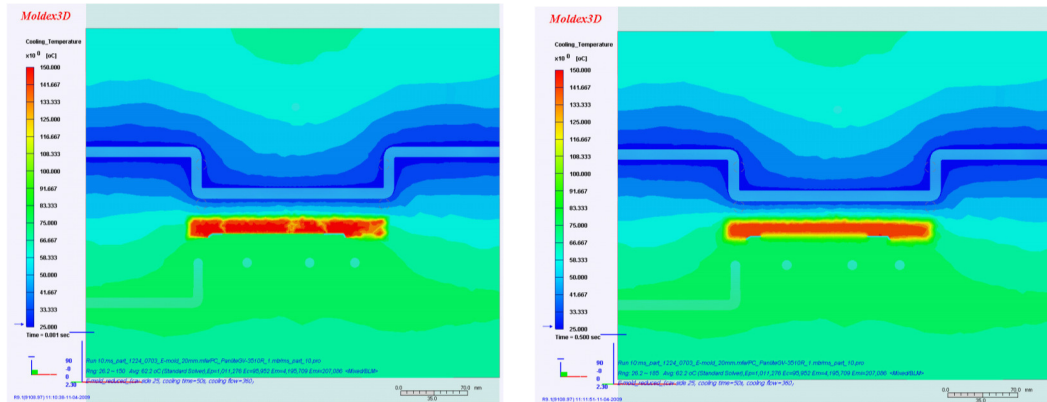

(a) 0.001s

(b) 0.5s (end of filling)

Figure-iv The temperature distribution of moldbase during filling phase in E-mold process (DRT Moldes, 2012)

	Weldline temperature
CIM	170°C ~200°C
RHCM	190°C ~220°C
IHM	205°C ~235°C
E-MOLD	210°C ~240°C

Table-i Temperature distribution around the weldline location for various technologies

## **ANNEX 2: The Work done by me in DRT in Injection**

Apart from observing the mold making process in the company, I was also assigned a task to study how the type of flow affects the final product during the plastic injection molding process and determine the most suitable flow type to conduct this process and the time duration for the whole process.

Injection molding is a heat transfer process, by injecting a molten liquid into a metal mold and transfer the heat into the metal, where it is transferred into the cooling media. Plastic injection molding is the most important plastic production method. It is also the most complex processes due to the many delicate adjustments. The flow of liquid during the process may affect the final quality of the product.

### **1. Parameters of Injection Molding**

The injection process should ensure the proper development of the product with smooth material filling and good mechanical properties. To accomplish this, the most important parameters to be controlled are temperature (melt temperature, mould temperature), pressure (plasticizing / back pressure, injection pressure, and holding pressure) and time (clamping time, injection time, holding time, cooling time).

**Temperature** - Temperature has a significant influence on the final properties of the material regardless of the part design. Two of the process conditions which have a substantial influence on the behaviour of polymer are melt temperature and mould temperature.

**Melt Temperature** - Melt temperature is the temperature of the polymer as it exits the injection machine nozzle and enters the mould. The correct choice of melt temperature is related to the quality and type of the plastic. The heating temperature of plastic should be always higher than the plastic flow temperature (melting point), but below its decomposition temperature.

**Mould Temperature** – Mould temperature is controlled by the coolant flowing through the channels in the mould. This determines the cooling rate of the injected plastic.

#### **Pressure**

**Plasticizing / Back Pressure** - The resistance of the molten plastic to flow forward is known as back pressure. Typically, the back pressure is around 7-10 bar, though it may be as low as 3.5 bar. Sometimes, back pressure is increased as much as 28 bars to improve melt uniformity, increase melt temperature or to eliminate air traps.

**Injection Pressure** – Injection pressure is the pressure given to the molten plastic by the screw when the screw is moving forward to push the plastic in the mould. If the

injection pressure is high, the flow ability of the plastic is increased and if the injection pressure is low, the flow ability is decreased and problems like bubbles and void will arise.

**Holding Pressure** – Even when the cavity is full, more pressure is given to melt plastic in order to pack the space completely. This pressure is called holding Pressure.

**Time** - The time needed for one injection cycle is called cycle time. The cycle time includes clamping time, injection time, holding time and cooling time.

**Clamping Time** – Clamping time is the time taken to clamp the mould in the injection moulding machine. If the clamping time is too long then the mould temperature will be too low while the plastic stays in the nozzle for a long time. If the clamping time is too short, mould temperature will be too high.

**Injection time** – Injection time is the time from when the plastic starts to melt to the time the plastic is filled in the cavity of the mould. Normally, the injection time for small parts is around 3-5 seconds and for large parts is around 10 seconds. Injection time always has inverse effect on the injection speed.

**Holding Time** – Holding time refers to time for continuing pressure on the plastic product. If the holding time is too short, the plastic product will not be tight enough and this may cause dent and unstable size. If the holding time is too long, stresses in the product will be increased.

**Cooling Time** – Cooling time runs from the finish of the holding pressure to the opening of the mould. Cooling time depends on the thickness of the product, thermal properties of plastic and crystallization characteristics.

## 2. Process and Equipment

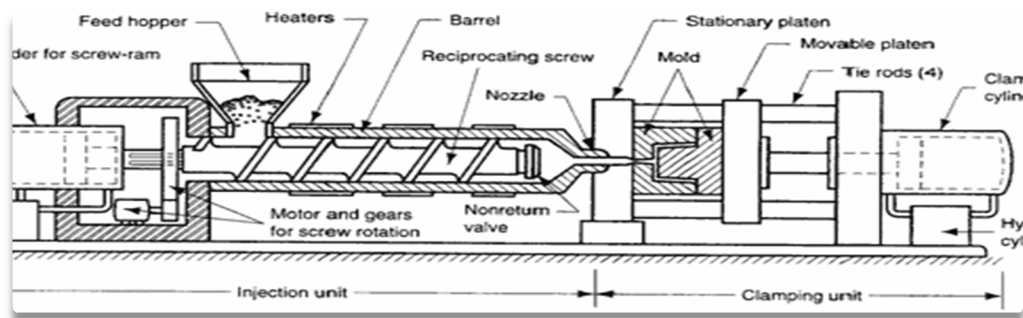

Injection machine (Bryce, 1996)

Equipment for injection moulding evolved from metal die casting. An injection moulding machine consists of two principal components:

The plastic injection unit and

The mould clamping unit.

**Injection Unit:** The injection unit is much like an extruder. It consists of a barrel that is fed from one end by a hopper containing a supply of plastic pellets. Inside the barrel is a screw whose operation surpasses that of an extruder screw in the following respect: in addition to turning for mixing and heating the polymer, it also acts as a ram which rapidly moves forward to inject molten plastic into the mould. A no return valve mounted near the tip of the screw prevents the melt from flowing backward along the screw threads. Later in the moulding cycle the ram retracts to its former position. Because of its dual action, it is called a reciprocating screw, which name also identifies the machine type. Older injection moulding machines used a simple ram (without screw flights), but the superiority of the reciprocating screw design has led to its widespread adoption in today's moulding plants. To summarize, the functions of the injection unit are to melt and homogenize the polymer, and then inject it into the mould cavity

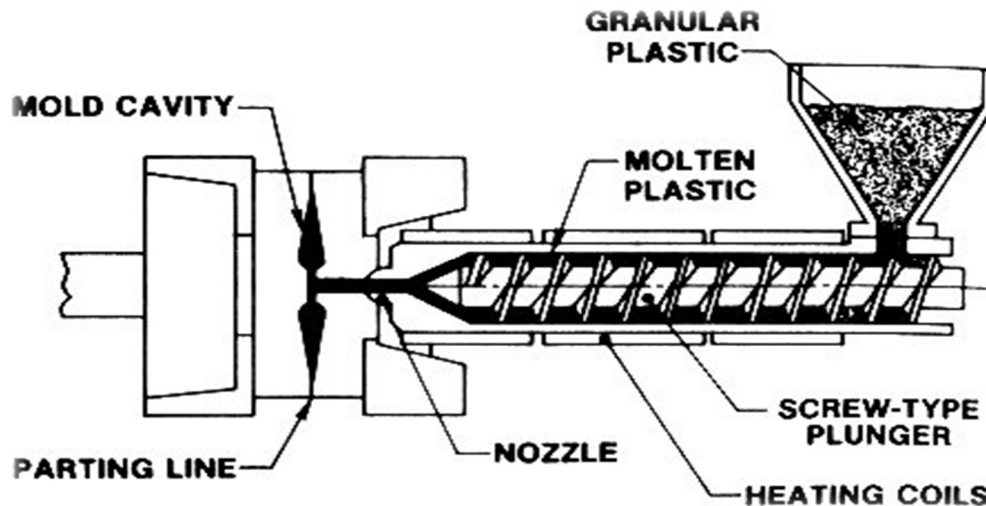

Molding section (Bryce, 1996)

**Molding Section:** Generally molds are made from hardened steel or aluminum having fiber glass coating it consists of

Stationary plate (Mold cavity) and

Movable plate (Mold core)

Mold Base (front half and rear half), runner gate etc.)

Gates (Edge gate, submarine gate, Fan gate) etc.

**Mold Function:** To give desired shape to material, to withstand the injection pressure and clamped forces, to properly distribute the ejected melt, Cool and cure the material.

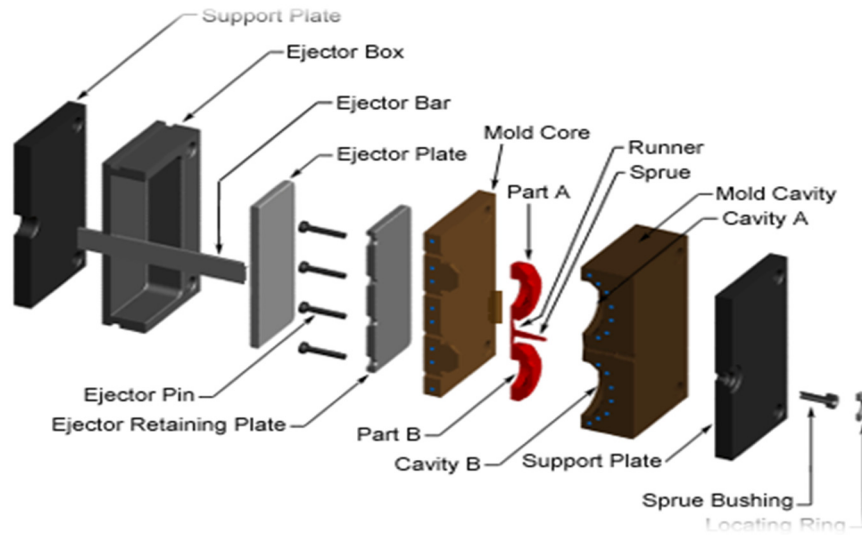

Mould (Bryce, 1996)

## Mould Function

**Clamping Unit:** The clamping unit is concerned with the operation of the mould. Its functions are to hold the two halves of the mould in proper alignment with each other;

Keep the mould closed during injection by applying a clamping force sufficient to resist the injection force; and

Open and close the mould at the appropriate times in the moulding cycle. The clamping unit consists of two platens, a fixed platen and a movable platen, and a mechanism for translating the latter. The mechanism is basically a power press that is operated by hydraulic piston or mechanical toggle devices of various types. Clamping forces of several thousand tons are available on large machines.

## Injection Machine (Bryce, 1996)

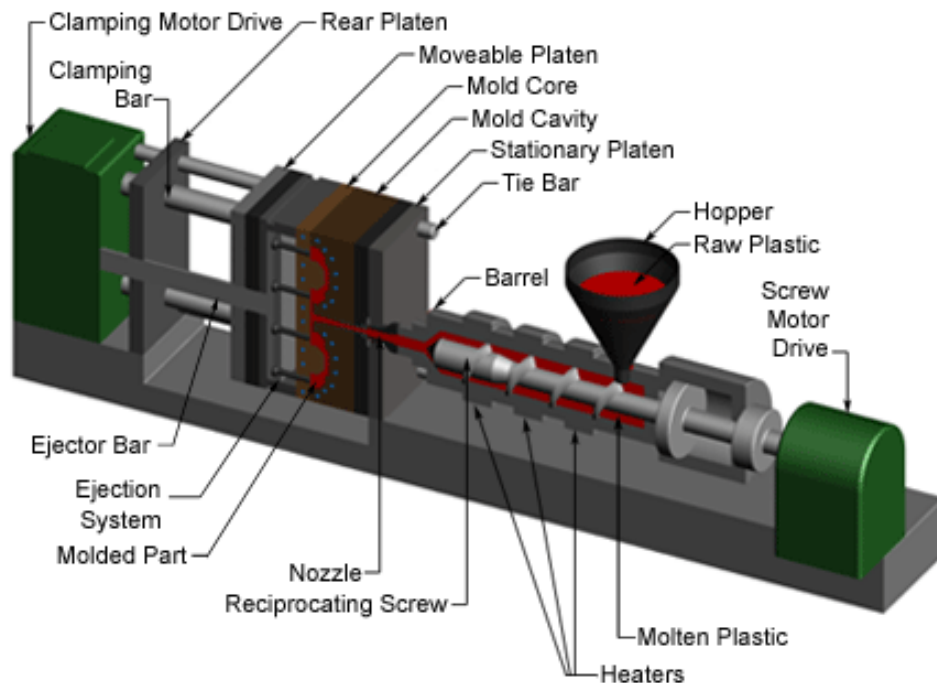

The cycle for injection moulding of a thermoplastic polymer proceeds in the following sequence. Let us pick up the action with the mould open and the machine ready to start a new moulding:

Mould is closed and clamped.

A shot of melt, which has been brought to the right temperature and viscosity by heating and by the mechanical working of the screw, is injected under high pressure into the mould cavity. The plastic cools and begins to solidify when it encounters the cold surface of the mould. Ram pressure is maintained to pack additional melt into the cavity to compensate for contraction during cooling.

The screw is rotated and retracted with the no return valve open to permit fresh polymer to flow into the forward portion of the barrel. Meanwhile, the polymer in the mould has completely solidified.

The mould is opened, and the part is ejected and removed.



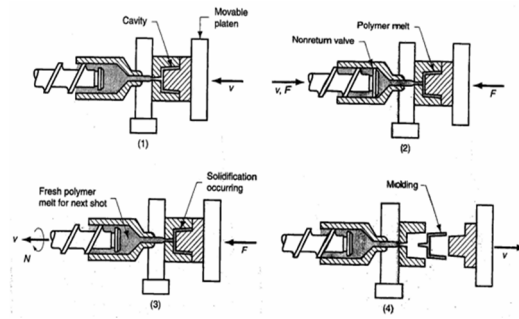

**PLASTIC GRANULES DROPPING ON TO SCREW THREAD**

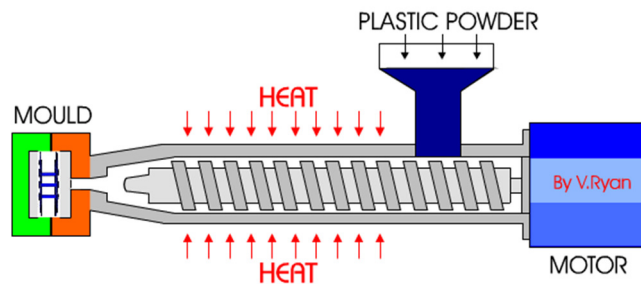

Plastic granules dropping on to screw thread (Bryce, 1996)

Parts made in a plastic injection moulding process can have their own unique set of possible defects. The following is one of the most common defects associated with the plastic injection process in which I worked on:-

**Sink Marks** (DRT Moldes, 2012)

Sinking is caused by the outer skin of plastic solidifying while the material inside is still molten and viscous. As it cools and solidifies, the material compacts. The best way to avoid these dimples is to design the part with a consistent wall thickness. However, many times the problem of sinking can be taken care of by adjusting the process parameters only.

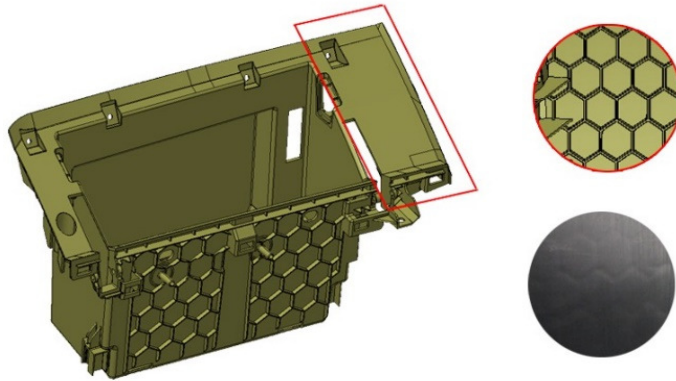

In these area of the part, exists the real possibility of appearing sink marks I suggest the reduction of rib thickness to prevent these situation in the existing plastic part.

## **Mold**

### MOLD TEMPERATURE TOO HIGH OPPOSITE RIBS

**Explanation:** Generally, a hot mold will allow a material to stay molten longer than a cold mold and cause the molecules to stay fluid longer before they cool and solidify. Upon ejection from the mold the material will be allowed to contract more than normal and excessive shrinkage will occur. This condition often occurs in the area of ribs because of the extra plastic in those areas, which requires more extensive cooling to maintain consistent shrinkage. Inconsistent shrinkage will result in sink marks.

**Solution:** Decrease the mold temperature to the point at which the material has the proper flow and packs out the mold without shorting. Start with the material suppliers recommendations and adjust accordingly. Allow 10 cycles for every 10-degree change for the process to re-stabilize.

### SMALL GATES AND/OR RUNNERS

**Explanation:** Gates and/or runners that are too small will cause excessive restriction to the flow of the molten plastic. Many plastics will then begin to solidify before they fill the cavity. The result is a material that is not fully contained within the metal mold surfaces and is allowed to shrink beyond normal expectations. The extended shrinkage causes sink marks.

**Solution:** Examine the gates and runners to optimize their size and shape. Do not overlook the sprue bushing as a long sprue may solidify too soon. Use a heated bushing

or extended nozzle to minimize sprue length. Ask the material supplier for data concerning gate and runner dimensioning for a specific material and flow rate.

### IMPROPER GATE LOCATION

**Explanation:** If certain materials are injected directly across a flat cavity surface they tend to slow down quickly as a result of frictional drag and cool off before the cavity is properly filled. The material is not held under proper pressure while solidifying and excessive shrinkage will cause sink marks as the part cools after ejection from the mold.

**Solution:** Relocate or redesign the gate so that the molten plastic is directed against an obstruction such as a core pin. This will cause the material to disperse and continue to flow instead of slowing down.

### EXCESSIVE THICKNESS AT MATING WALLS

**Explanation:** When a wall meets another wall, or when a boss is located on a wall, the area where they form a junction becomes a larger mass of plastic than the area surrounding it. The surrounding area cools and is already solidified while the larger mass continues to cool and shrink. Because the surrounding area is solid, non-uniform shrinkage occurs as the large mass area shrinks in on itself, causing sink marks to appear.

**Solution:** Although it is good design practice to maintain all walls at a uniform thickness, in areas where a junction is formed, one of the walls should be between 60% and 70% of the mating wall thickness. This will minimize the mass at the junction until the shrinkage is equal in all areas and sink marks will not develop.

## **Material**

### IMPROPER FLOW RATE

**Explanation:** Resin manufacturers supply specific formulations in a range of standard flow rates. Thin-walled products may require an easy flow material while thick-walled products can use a material that is stiffer. It is better to use as stiff a flow as possible because that improves physical properties of the molded part. But the stiff material will be more difficult to push and this may result in a less dense material filling the cavity image. The lower this density, the higher the amount of shrinkage that will occur after ejection, and sink marks may occur due to an imbalance of shrinkage factors.