

Boise State University
ScholarWorks

Electrical and Computer Engineering Faculty
Publications and Presentations

Department of Electrical and Computer
Engineering

1-1-2007

A Five-Level Three-Phase Hybrid Cascade Multilevel Inverter Using a Single DC Source for a PM Synchronous Motor Drive

John N. Chiasson
Boise State University

Burak Ozpineci
Oak Ridge National Laboratory

Leon M. Tolbert
University of Tennessee, Knoxville

A Five-Level Three-Phase Hybrid Cascade Multilevel Inverter Using a Single DC Source for a PM Synchronous Motor Drive

John N. Chiasson¹, Burak Özpıneci², and Leon M. Tolbert^{2,3}

¹ECE Department, MS 2075, Boise State University, Boise Idaho 83725, johnchiasson@boisestate.edu

²Oak Ridge National Laboratory, Oak Ridge TN, ozpinecib@ornl.gov, tolbertlm@ornl.gov

³ECE Department, University of Tennessee, Knoxville, TN 37996, tolbert@utk.edu.

Abstract—The interest here is in using a single DC power source to construct a 3-phase 5-level cascade multilevel inverter to be used as a drive for a PM traction motor. The 5-level inverter consists of a standard 3-leg inverter (one leg for each phase) and an H-bridge in series with each inverter leg, which use a capacitor as a DC source. It is shown that one can simultaneously maintain the regulation of the capacitor voltage while achieving an output voltage waveform which is 25% higher than that obtained using a standard 3-leg inverter by itself.

Index Terms—Multilevel Converter, PM motor drive

I. INTRODUCTION

A cascade multilevel inverter is a power electronic device built to synthesize a desired AC voltage from several levels of DC voltages. Such inverters have been the subject of research in the last several years [1][2][3][4][5], where the DC levels were considered to be identical in that all of them were capacitors, batteries, solar cells, etc. In [6], a multilevel converter was presented in which the two separate DC sources were the secondaries of two transformers coupled to the utility AC power. Corzine et al [7] have proposed using a single DC power source and capacitors for the other DC sources. A method was given to transfer power from the DC power source to the capacitor in order to regulate the capacitor voltage. A similar approach was later (but independently) proposed by Du et al [8]. These approaches required a DC power source for each phase. The approach here is very similar to that of the Corzine et al [7] and Du et al [8] with the important exception that a standard 3-leg inverter is used for the first power source (one leg for each phase) so that a single DC power source is all that is required for three phase. This topology was proposed by one of the authors in [9].

Specifically, the interest here is in using a single DC power source connected to a standard 3-leg inverter which in turn is connected to capacitors to form a 3-phase 5-level cascade multilevel inverter to be used as a drive for a PM traction

⁰Prepared by the Oak Ridge National Laboratory, Oak Ridge, Tennessee 37831, managed by UT-Battelle for the U.S. Department of Energy under contract DE-AC05-00OR22725.

The submitted manuscript has been authored by a contractor of the U.S. Government under Contract No. DE-AC05-00OR22725. Accordingly, the U.S. Government retains a non-exclusive, royalty-free license to publish from the contribution, or allow others to do so, for U.S. Government purposes.

motor. The 5-level inverter consists of a standard 3-leg inverter (one leg for each phase) and an H-bridge in series with each inverter leg, which uses a capacitor as a DC source. It is shown that one can simultaneously maintain the regulation of the capacitor voltage while achieving an output voltage waveform which is 25% higher than that obtained using a standard 3-leg inverter by itself.

II. MULTILEVEL INVERTER ARCHITECTURE

Fig. 1 shows a DC source connected to a single leg of a standard 3-leg inverter.

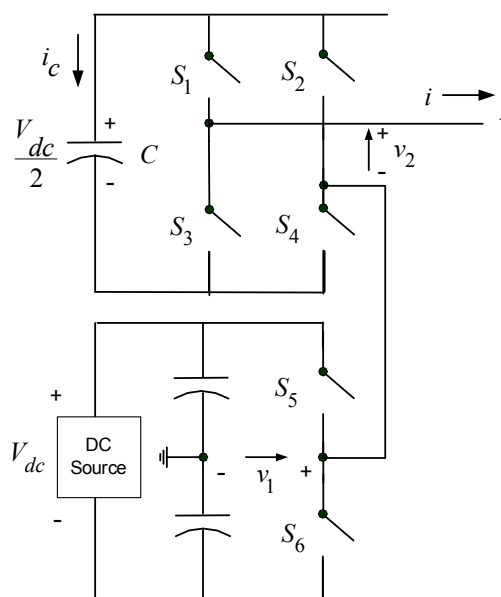

Fig. 1. One leg of a 3-leg inverter connected to a full H-bridge with a capacitor DC source.

The output voltage v_1 of this leg (with respect to the ground) is either $+V_{dc}/2$ (S_5 closed) or $-V_{dc}/2$ (S_6 closed). This leg is connected in series with a full H-bridge which in turn is supplied by a capacitor voltage. If the capacitor is kept charged to $V_{dc}/2$, then the output voltage of the H-bridge can take on the values $+V_{dc}/2$ (S_1 & S_4 closed), 0 (S_1 & S_2 closed or S_3 & S_4 closed), or $-V_{dc}/2$ (S_2 & S_3 closed). An example

output waveform that this topology can achieve is shown in the top of Fig. 2. When the output voltage $v = v_1 + v_2$ is required to be zero, one can either set $v_1 = +V_{dc}/2$ and $v_2 = -V_{dc}/2$ or $v_1 = +V_{dc}/2$ and $v_2 = +V_{dc}/2$. It is this flexibility in choosing how to make that output voltage zero that is exploited to regulate the capacitor voltage. In more detail, consider 2.

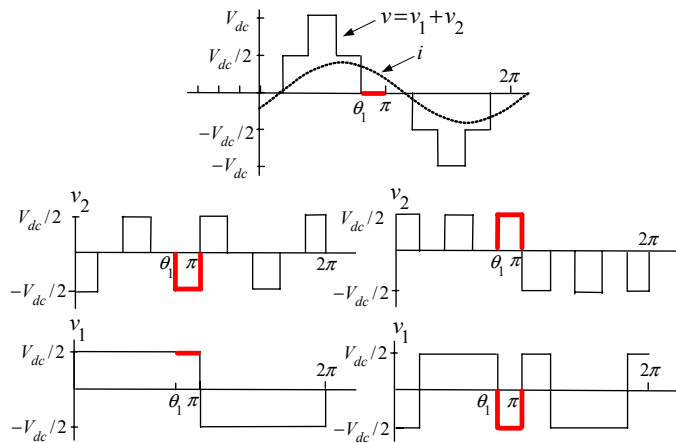

Fig. 2. To make the output voltage zero for $\theta_1 \leq \theta \leq \pi$, one can either set $v_1 = +V_{dc}/2$ and $v_2 = -V_{dc}/2$ (bottom left) or $v_1 = +V_{dc}/2$ and $v_2 = +V_{dc}/2$ (bottom right).

During $\theta_1 \leq \theta \leq \pi$, the output voltage in Fig. 2 is zero and the current $i > 0$. If S_1 & S_4 are closed (so that $v_2 = +V_{dc}/2$) along with S_6 closed (so that $v_1 = -V_{dc}/2$), then the capacitor is *discharging* ($i_c = -i < 0$ see Fig. 1) and $v = v_1 + v_2 = 0$. On the other hand, if S_2 & S_3 are closed (so that $v_2 = -V_{dc}/2$) and S_5 is also closed (so that $v_1 = +V_{dc}/2$), then the capacitor is *charging* ($i_c = i > 0$ see Fig. 1) and $v = v_1 + v_2 = 0$.

The case $i < 0$ is accomplished by simply reversing the switch positions of the $i > 0$ case for charge and discharge of the capacitor. Consequently, the method consists of monitoring the output current and the capacitor voltage so that during periods of zero voltage output, either the switches S_1 , S_4 , and S_6 are closed or the switches S_2 , S_3 , S_5 are closed depending on whether it is necessary to charge or discharge the capacitor.

Remark

As Fig. 2 illustrates, this method of regulating the capacitor voltage depends on the voltage and current not being in phase. That is, one needs positive (or negative) current when the voltage is passing through zero in order to charge or discharge the capacitor. Consequently, the amount of capacitor voltage the scheme can regulate depends on the power factor.

III. SIMULATION RESULTS USING MULTILEVEL PWM

A simulation of the multilevel converter driving a PM synchronous machine was carried out. The motor is controlled using a standard field-oriented controller [10]. The blocks marked phase 1, phase 2, and phase 3 contain the modeling of the multilevel converter. The switching scheme is based on the standard multilevel PWM scheme [11]. The scheme is modified so that during those time periods when the converter is supplying zero volts, either the switches S_1 , S_4 , and S_6 are closed or the switches S_2 , S_3 , S_5 are closed depending on

whether the current is positive or negative and whether it is necessary to charge or discharge the capacitor.

The DC link voltage V_{dc} was set to 200 V so that the 3-leg inverter puts out ± 100 V. The capacitors were regulated to 100 V. The motor's inertia is $J = 0.1$ kg-m², the motor has $n_p = 4$ pole-pairs, the stator resistance is $R_S = 0.065$ Ohms, the stator inductance is $L_S = 3$ mH, the torque/back-emf constant $K_T = K_b = 0.37$ Nm/A (V/rad/sec) and the load torque $\tau_L = 19$ Nm. The capacitor value is $C = 0.01$ F.

For comparison purposes, simulations were performed using both the multilevel inverter of Fig. 1 capable of supplying ± 200 V and a standard 3-leg inverter (i.e., only the bottom half of Fig. 1) capable of supplying ± 100 V. Though the multilevel inverter can provide up to ± 200 V, it cannot do this and maintain regulation of the capacitor voltages. As pointed out in the above remark, the ability to regulate the capacitor voltage depends on the power factor of the load. The PM motor was run to achieve the highest possible speed under the given load and available voltage. This is shown in Figs. 3 and 4. The standard 3-leg inverter could only achieve a maximum speed of 212 rad/sec while the proposed multilevel inverter could drive the motor up to 275 rad/sec using the same DC source voltage.

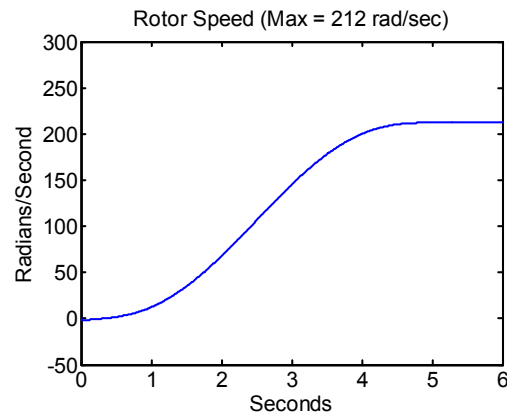

Fig. 3. Rotor speed achievable using a standard 3-leg inverter

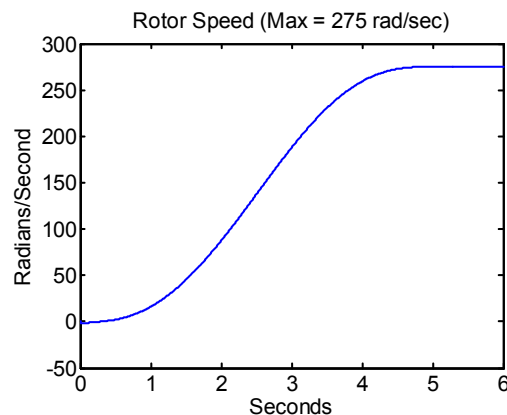

Fig. 4. Rotor speed achievable using the proposed multilevel inverter.

The corresponding voltages for the speed trajectories of Fig.

3 and Fig. 4 are shown in Fig. 5 and Fig. 6, respectively. The standard 3-leg inverter produces a nearly six step waveform of $V_{dc}/2 = 100$ V maximum corresponding to a fundamental voltage of $\frac{4V_{dc}}{2\pi} = 127$ V peak while the multilevel inverter is supplying 170 V peak in steady state and up to 180 V before steady state.

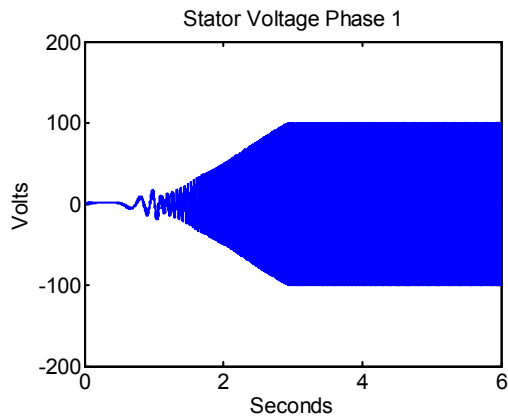

Fig. 5. Voltage using a standard 3-leg inverter.

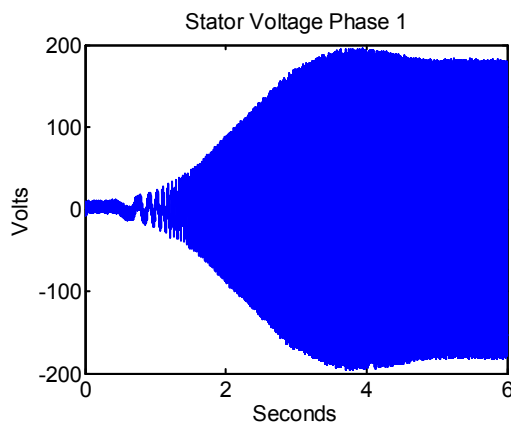

Fig. 6. Voltage obtained using the proposed multilevel inverter.

The corresponding torques for the above trajectories are shown in Fig. 7 and Fig. 8, respectively. The peak torque is larger for the cascade multilevel inverter drive because the motor is being accelerated to a higher speed. The chattering shown in the torque response of the standard 3-leg inverter is due to the fact that the voltage is undergoing saturation (see Fig. 5).

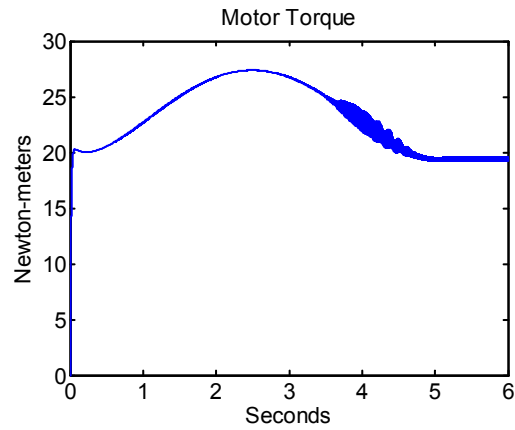

Fig. 7. Torque using standard 3-leg inverter.

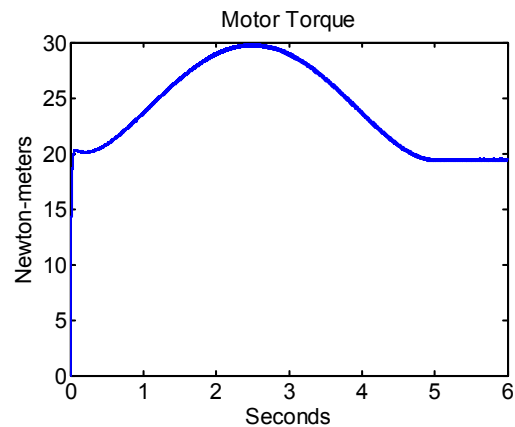

Fig. 8. Torque using proposed multilevel inverter.

The capacitor voltage as a function of time is plotted in Fig. 9 showing that it is kept within about 2 volts of the desired value. An enlarged view of the capacitor voltage is shown in Fig. 10 showing the regulation of the voltage in more detail. The variation in the voltage will be less if one uses a larger value of capacitance ($C = 0.01$ F here).

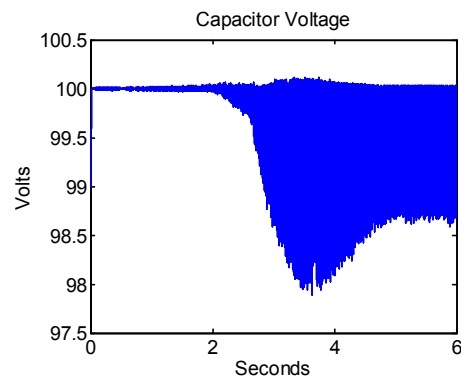

Fig. 9. Capacitor voltage versus time.

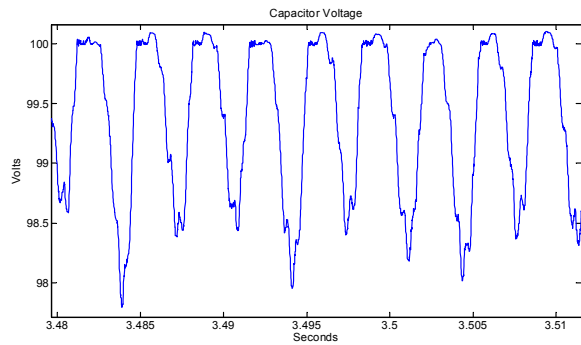

Fig. 10. Expanded view of the capacitor voltage as a function of time.

IV. CAPACITOR VOLTAGE REGULATION

To illustrate how the capacitor voltage regulation works, scaled versions of the capacitor voltage, stator voltage, and stator current for phase 1 are shown in Fig. 11 for a fundamental frequency switching scheme (The technique is easier to illustrate using a fundamental switching scheme though the PWM scheme uses the same method). Note that the capacitor discharges when the inverter is supplying ± 200 V, stays constant when the inverter is supplying ± 100 V, and recharges when the inverter is supplying 0 V.

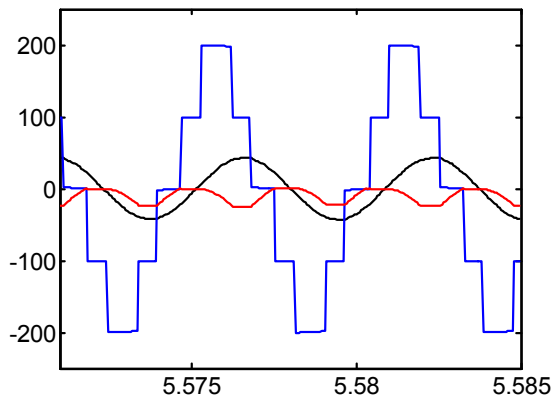

Fig. 11. Scaled capacitor voltage, stator current and stator voltage versus time in seconds.

For example, a little after $t = 5.575$ seconds, the current (in black) becomes positive and the inverter is supplying 200 V (blue). The capacitor voltage (red) then decreases. Following this, when the inverter is only supplying 100 V, the capacitor voltage is constant. Next, the inverter is producing 0 V and during this time the capacitor is charged to increase its voltage.

V. DISCUSSION AND FUTURE WORK

A five-level cascade multilevel inverter topology has been proposed that requires only a single standard 3-leg inverter and capacitors as the power sources. The capacitors obtain their power from the 3-leg inverter allowing the cascade multilevel inverter to provide significantly more voltage from a given

DC power source than just a three leg inverter alone. It was shown that the capacitor voltages could be maintained (regulated) subject to large enough power factor. Both PWM and fundamental frequency switching schemes can be used.

REFERENCES

- [1] M. Klabunde, Y. Zhao, and T. A. Lipo, "Current control of a 3 level rectifier/inverter drive system," in *Conference Record 1994 IEEE IAS Annual Meeting*, 1994, pp. 2348–2356.
- [2] W. Menzies, P. Steimer, and J. K. Steinke, "Five-level GTO inverters for large induction motor drives," *IEEE Transactions on Industry Applications*, vol. 30, no. 4, pp. 938–944, July 1994.
- [3] D. W. Novotny and T. A. Lipo, *Vector Control and Dynamics of AC Drives*. Oxford University Press, New York, 1996.
- [4] J. K. Steinke, "Control strategy for a three phase AC traction drive with three level GTO PWM inverter," in *IEEE Power Electronic Specialist Conference (PESC)*, 1988, pp. 431–438.
- [5] J. Zhang, "High performance control of a three level IGBT inverter fed AC drive," in *Conf. Rec. IEEE IAS Annual Meeting*, 1995, pp. 22–28.
- [6] M. Manjrekar, P. K. Steimer, and T. Lipo, "Hybrid multilevel power conversion system: A competitive solution for high-power applications," *IEEE Transactions on Industry Applications*, vol. 36, no. 3, pp. 834–841, May/June 2000.
- [7] K. A. Corzine, F. A. Hardrick, and Y. L. Familant, "A cascaded multi-level H-bridge inverter utilizing capacitor voltages sources," in *Proceedings of the IASTED International Conference*. Palm Springs CA, 2003, pp. 290–295.
- [8] Z. Du, L. M. Tolbert, J. N. Chiasson, and B. Ozpineci, "Cascade multilevel inverter using a single dc source," in *Proceedings of the Applied Power Electronics Conference (APEC)*, 2006, pp. 426–430, Dallas TX.
- [9] B. Ozpineci, "Single DC source for a three-phase multilevel inverter," Private communication, 2006.
- [10] J. Chiasson, *Modeling and High-Performance Control of Electric Machines*. John Wiley & Sons, 2005.
- [11] D. G. Holmes and T. Lipo, *Pulse Width Modulation for Power Electronic Converters*. Wiley Interscience, 2003.