

Electronic Thesis and Dissertation Repository

---

4-18-2016 12:00 AM

## Synthesis and Electrochemiluminescence of Thiophene Substituted Benzosiloles

Tyler J. B. Day  
*The University of Western Ontario*

Supervisor  
Dr. Brian Pagenkopf  
*The University of Western Ontario*

Graduate Program in Chemistry  
A thesis submitted in partial fulfillment of the requirements for the degree in Master of Science  
© Tyler J. B. Day 2016

Follow this and additional works at: <https://ir.lib.uwo.ca/etd>

 Part of the [Materials Chemistry Commons](#), and the [Organic Chemistry Commons](#)

---

### Recommended Citation

Day, Tyler J. B., "Synthesis and Electrochemiluminescence of Thiophene Substituted Benzosiloles" (2016).  
*Electronic Thesis and Dissertation Repository*. 3709.  
<https://ir.lib.uwo.ca/etd/3709>

This Dissertation/Thesis is brought to you for free and open access by Scholarship@Western. It has been accepted for inclusion in Electronic Thesis and Dissertation Repository by an authorized administrator of Scholarship@Western. For more information, please contact [wlsadmin@uwo.ca](mailto:wlsadmin@uwo.ca).

## Abstract and Keywords

There has been increasing interest in the synthesis of siloles over the past 20 years due to their applications as chemoselective sensors and light emitting diodes. The standard synthesis of siloles involves a one-pot reductive cyclization followed by Negishi cross-coupling, which was modified by the Pagenkopf group to allow the synthesis of dissymmetric siloles. This modified synthesis allows siloles to be tuned to improve their fluorescent properties via varying substituents on the silole. This culminated in the synthesis of a series of 2,5-bis(thiophene)siloles with bulky silyl substituents that displayed excellent electrochemiluminescent properties.

In the past decade there has been a large push for effective synthetic methods for making benzosiloles. The synthetic method developed by the Chatani group is particularly interesting because of the large variety of benzosiloles that could be synthesized in high yields. Combining the Chatani benzosilole synthesis with the Pagenkopf group's knowledge in tuning siloles should result in new benzosilole chromophores that might have applications as biosensors or in solar cells.

This work describes the synthesis of benzosiloles containing oligothiophenes substituted at the C2 and C3 positions. Benzosiloles are formed in a cycloaddition reaction from 2-silylphenylborates and thiophene-acetylenes with a rhodium catalyst. In total seven benzosiloles were synthesized including those with electron donating and electron withdrawing groups. Their ECL properties were then tested to discover that both highly conjugated bis(2,3-terthiophene)benzosilole and 6-cyano-bis(2,3-terthiophene)benzosilole displayed the best ECL properties of those synthesized.

**Key Words:** Benzosilole, Silole, Electrochemiluminescence, Rhodium catalyzed cycloaddition, Oligothiophenes

## **Acknowledgments**

I would like to thank my family and friends for all their support on this journey. I would also like to thank my colleagues for all their support and friendship during my time as a graduate student. In particular, I want to thank Geoff Philips for the good times spent in the lab. I also wish to thank Naresh Vemula and Tristan Chidley for their friendship while working in the lab. I would like to thank Dr. Zhifeng Ding and his group for their work on the ECL and PL experiments. I would also like to thank the members of the Kerr group for their helpful critiques during presentations. Lastly I would like to thank Professor Brian Pagenkopf for his guidance and for the opportunity to work in his research group.

## Table of Contents

Abstract and Keywords.....	i
Acknowledgments.....	ii
Table of Contents.....	iii
List of Tables .....	iv
List of Figures.....	v
List of Schemes.....	vii
List of Abbreviations .....	ix
1.0 Introduction to Siloles.....	1
1.3 Synthesis of Benzosiloles .....	7
1.4 Applications of Siloles.....	13
2.0 Results and Discussion .....	19
2.1 Synthesis of 2-Silylphenylboronic Acids.....	19
2.2 Synthesis of Thiophene Acetylene Species .....	23
2.3 Synthesis of 2-diisopropylmethylsilylphenylboronic Acid .....	28
2.4 Synthesis of Nitrile Containing 2-silylphenylboronic acid.....	33
2.5 Synthesis of Benzosiloles .....	34
2.6 Results of ECL Experiments.....	41
3.0 Conclusions and Future Work .....	47
4.0 Experimental.....	48
4.1 General Experimental Details .....	48
4.2 Experimental Details.....	49
Appendix I NMR Spectral Data.....	66
Curriculum Vitae.....	87

## List of Tables

Table 1 Attempted synthesis of isopropyl substituted benzosiloles .....	38
---	----

## List of Figures

Figure 1 Relative HOMO (black) and LUMO (white) levels for silole and other heterocycles based on HF/6-31G* calculations. <sup>1</sup> Reproduced with Permission from the Royal Society of Chemistry.....	1
Figure 2 Tamao's synthesis of siloles from 1994. ....	2
Figure 3 Absorption data of polymerized siloles.....	3
Figure 4 Synthesis of symmetric 2,5-diaryl siloles.....	3
Figure 5 Dissymmetric donor-acceptor siloles and oligomeric siloles.....	4
Figure 6 Extended silole chromophores. ....	5
Figure 7 Highly conjugated phenylene ethynylene substituted siloles.....	5
Figure 8 The steric rigidity of 2,5-arylene ethynylenes.....	6
Figure 9 Thiophene-silole hybrids to tune electrochemiluminescence.....	7
Figure 10 Illustration of fluorescence detection of DNA with AIE-active silole. ....	14
Figure 11 Modified AIE-active 2,3,4,5-tetraphenylsilole for use as a bifunctional material in OLEDs. ....	16
Figure 12 Structure of silole based nitroaromatic explosive sensor. ....	16
Figure 13 Triarylamine based solar cell sensitizers including the dithienosilole moiety as a spacer. ....	17
Figure 14 General mechanism for annihilation ECL, where radical cation and radical anion to form R*. This excited species relaxes back down to the ground state and releases light.....	41
Figure 15 General mechanism of coreactant ECL with TPrA as coreactant. The chromophore (D) gets oxidized to radical cation while TPrA is oxidized followed by loss of H <sup>+</sup> . The two resulting radical species then react to form the excited species D* which emits light upon relaxation.....	42
Figure 16 Cyclic Voltammogram (red) and ECL-voltage curve (blue) of 108 in an annihilation system. The applied voltage sweeps from 1 V to -3 V and back to 1 V in a cyclic pattern over a period of time. The CV shows 2 non-reversible oxidations and reductions, while the ECL-voltage curve shows photocurrent of over 15 nA. ....	44
Figure 17 Cyclic voltammogram (red) and ECL-voltage curve (blue) of 108 with TPrA as coreactant. The voltage is applied linearly versus time from 0 V to 1.2 V. The ECL intensity is represented as the photocurrent generated, which is 80 nA for 111.....	45

Figure 18 Cyclic Voltammogram (red) and ECL-voltage curve (blue) of 111 in an annihilation system. The applied voltage sweeps from 1 V to -3 V and back to 1 V in a cyclic pattern over a period of time. The CV shows 2 non-reversible oxidations and reductions, while the ECL-voltage curve shows photocurrent of 7 nA plus an additional 1 nA being generated via a side reaction with the nitrile. .... 45

Figure 19 Cyclic voltammogram (red) and ECL-voltage curve (blue) of 111 with TPrA as coreactant. The voltage is applied linearly versus time from 0 V to 1.4 V. The ECL intensity is represented as the photocurrent generated, which is 70 nA for 111. .... 46

Figure 20 ECL spectra of 108 showing  $\lambda_{\text{max}}$  of around 500 nm. .... 47

## List of Schemes

Scheme 1 Byproducts formed as a result of unknown impurities in the lithium naphthalenide. ...	7
Scheme 2 Synthesis of symmetric and asymmetrical dibenzosiloles. ....	8
Scheme 3 Synthesis of dibenzosiloles via metal catalyzed silicon-carbon bond cleavage.....	9
Scheme 4 Murakami's approach to 3-allylbenzosiloles using a gold catalyst.....	10
Scheme 5 Nakamura's routes for benzosilole synthesis. ....	11
Scheme 6 Chatani's initial dibenzosilole synthesis. ....	11
Scheme 7 General reaction for Chatani's benzosilole synthesis method. ....	12
Scheme 8 The catalytic cycle for the formation of benzosiloles with [RhCl(cod)] <sub>2</sub> . ....	13
Scheme 9 Use of siloles as a fluorescence turn on detector of cyanide.....	15
Scheme 10 Linking of benzosilole chromophore to a biomolecule.....	18
Scheme 11 The synthesis of 2-trimethylsilylphenylboric acid from 1,2-dibromobenzene. ....	20
Scheme 12 <i>ortho</i> -Directing agent for ruthenium-catalyzed aromatic C-H silylation. <sup>53</sup> .....	20
Scheme 13 Synthetic routes to benzosiloles using <i>ortho</i> -directing carbamates. ....	21
Scheme 14 Synthesis of 2-silylphenylborates from 1,2-diiodobenzene utilizing isopropyl Grignard. ....	22
Scheme 15 The synthesis of 55 using BDEA as a protecting group followed by lithiation and TMSCl trapping. ....	23
Scheme 16 Synthesis of oligothiophenes.....	24
Scheme 17 Various routes for synthesizing haloterthiophenes. ....	25
Scheme 18 The two routes to synthesize di(thiophene)ethynes. ....	26
Scheme 19 Synthesis of thiophene acetylene species. ....	28
Scheme 20 Attempted synthesis of 2-triethylphenylboronic acid. ....	29
Scheme 21 Synthesis of diisopropylmethylchlorosilanes.....	30
Scheme 22 Synthesis of 2-diisopropylmethylphenylboronic acid.....	31
Scheme 23 Synthesis of 2,5-bis(trimethylsilyl)-4-nitrilephenylboronic acid. ....	33
Scheme 24 Synthesis of oligothiophene substituted benzosiloles. ....	35
Scheme 25 Synthesis of nitrile substituted benzosiloles.....	37
Scheme 26 Attempted reduction of nitrile with nickel boride and LAH.....	39



Scheme 27 Failed reduction with diisopropylaminoborane.....	40
Scheme 28 Effective reduction the nitrile with trifluoroacetic acid and sodium borohydride. ....	40

## List of Abbreviations

OAc	acetate
AcOH	acetic acid
ACQ	aggregate-caused quenching
AIE	aggregate induced emission
BDEA	N-butyl-diethanolamine
Bu	butyl
CAM	ceric ammonium molybdate
Cod	cyclooctadiene
CV	cyclic Voltammogram
Cy	cyclohexyl
DA	donor-acceptor
DABCO	1,4-diazabicyclo[2.2.2]octane
DEA	diethanolamine
DMA	dimethylacetamide
DMAP	4-dimethylaminopyridine
DME	1,2-dimethoxyethane
DMF	dimethylformamide
DMSO	dimethylsulfoxide
DNA	deoxyribonucleic acid
Dppf	(diphenylphosphino)ferrocene
Dppp	(diphenylphosphino)propane
DBU	1,8-diazabicyclo[5.4.0]undec-7-ene
ECL	electrochemiluminescence

ET	electron transporting
Et	ethyl
GPC	gel permeation chromatography
hept	heptyl
hex	hexyl
HOMO	highest occupied molecular orbital
<i>i</i> Pr	<i>iso</i> -propyl
LDA	lithium diisopropylamine
LiNaph	lithium naphthalenide
LUMO	lowest unoccupied molecular orbital
OLED	organic light emitting diodes
OSC	organic solar cells
Me	methyl
mmol	millimole(s)
NBS	N-bromosuccinimide
NCP	N-chlorophthalimide
Neop	neopentyl glycolato
NIS	N-iodosuccinimide
Ph	phenyl
PL	photoluminescence
Pza-H <sub>2</sub>	2-pyrazol-5-ylaniline
T	thiophene
TBAF	tetrabutylammonium fluoride
<i>t</i> Bu	<i>tert</i> -butyl
OTf	trifluoromethanesulfonate

TFA	trifluoroacetic acid
TES	triethylsilyl
THF	tetrahydrofuran
TLC	thin layer chromatography
TMEDA	tetramethylethylenediamine
TMS	trimethylsilyl
TMSA	(trimethylsilyl)acetylene
UV	ultra-violet

## 1.0 Introduction to Siloles

Siloles are a category of heterocycles where silicon replaces the saturated carbon in cyclopentadiene. Due to their applications in electrochemiluminescence (ECL) sensors and light emitting diodes, the development of  $\pi$ -conjugated silole rings have seen increasing interest recently.<sup>1</sup> Siloles exhibit unique electrochemical and photophysical properties, due to a low lying LUMO when compared to the HOMO. The low lying LUMO in siloles arises from  $\sigma^*$ - $\pi^*$  conjugation between the  $\sigma^*$  orbital in the silylene moiety and the  $\pi^*$  orbital in the cyclobutadiene moiety. This gives the silole ring high electron accepting properties, which is further evident by comparing them with other similar heterocycles<sup>2</sup> (**Figure 1**).

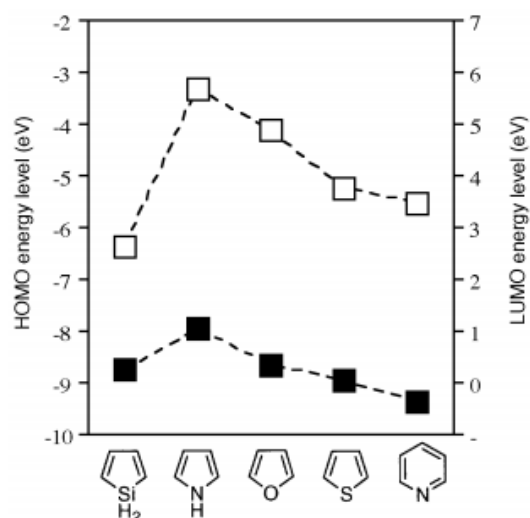

**Figure 1** Relative HOMO (black) and LUMO (white) levels for silole and other heterocycles based on HF/6-31G\* calculations.<sup>1</sup> Reproduced with Permission from the Royal Society of Chemistry.

Research into the synthesis of siloles has been slow to develop compared to other heterocycles such as thiophenes or pyrroles, in part because of the difficulty in silole synthesis. Siloles have been around for more than 50 years when Braye and Hubel<sup>3</sup> synthesized the first silole in 1959, but it wasn't until pioneering work by Tamao and coworkers that siloles piqued interest. In 1994 the desire to develop  $\pi$ -conjugated polymers using siloles as building blocks led to the

development of methods to functionalize these heterocycles.<sup>4</sup> Tamao developed the first of these methods starting from diethynylsilane and adding it to a solution of lithium naphthalenide (LiNaph), which undergoes radical coupling to furnish 2,5-dilithiosiloles. This allows the lithium halogen exchange with bromine to give 2,5 dibromo species that can be coupled with thiophenes or phenylacetylenes to give products **3** and **4** (**Figure 2**).<sup>5</sup>

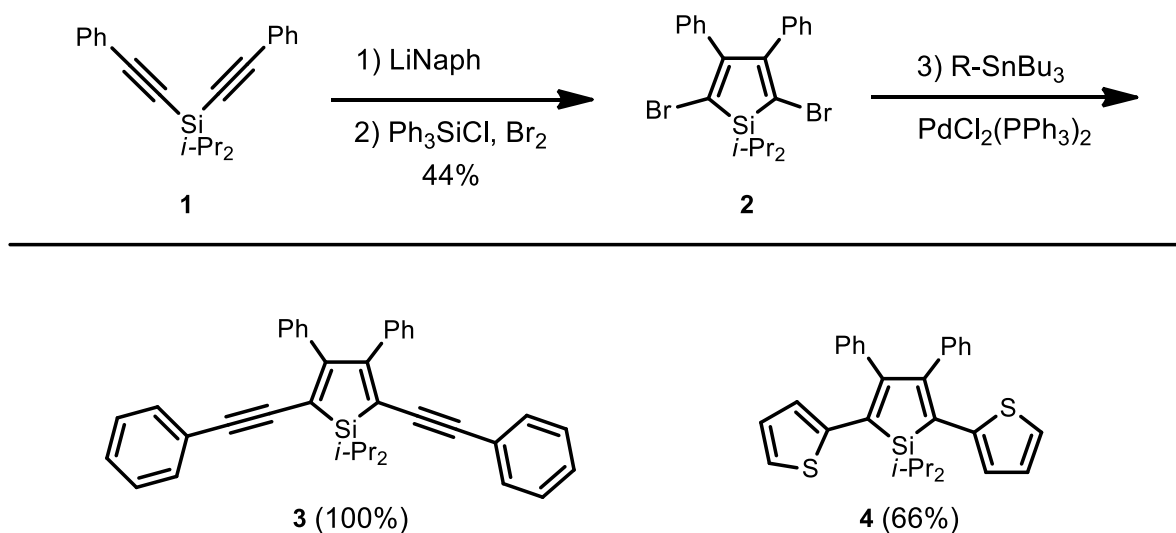

**Figure 2** Tamao's synthesis of siloles from 1994.

The first  $\pi$ -conjugated silole polymers were developed by Barton in 1997 and consisted of 2,5-diethynylsilole polymers linked by a benzene unit (**5**, **Figure 3**).<sup>6</sup> This polymer displayed red-shifted absorptions versus poly (phenylethynylene)s or poly (thiophene ethynylene)s ( $\lambda_{\text{max}}$  425, 438 respectively),<sup>7,8</sup> Then in 1998 Tamao synthesized a series of 2,5-diethynylsiloles derivatives and their polymers with a variety of terminal groups. Silole monomers (**4**, **Figure 2**) or polymers (**6**, **Figure 3**) supporting diethynylthiophene moieties proved to have longer wavelengths ( $\lambda_{\text{max}}$  576 nm), than the pyridine or phenyl derivatives.<sup>9</sup>



**Figure 3** Absorption data of polymerized siloles.

In a follow up study, Tamao's group synthesized a number of 2,5-symmetric arylsiloles to optimize their physical properties.<sup>10</sup> This was part of continuing research towards the development of efficient electron transporting materials. Different arylsiloles were synthesized using a modified method that employs a zinc intermediate to make 2,5 substituted siloles in one-pot fashion. These siloles included pyridine, thiophene, various mono-substituted phenyl rings, and extended  $\pi$ -conjugated systems shown in (**Figure 4**). The 2,5-di(2-pyridyl)silole showed low reduction potential making it a good candidate as an electron-transport material (ET), while the 2,5-bis(bithienyl)silole **12** showed promise as an emissive material.

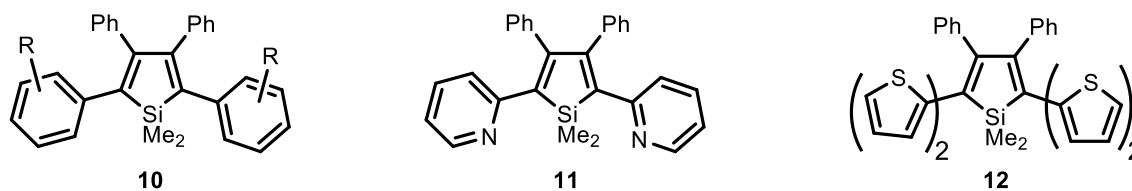
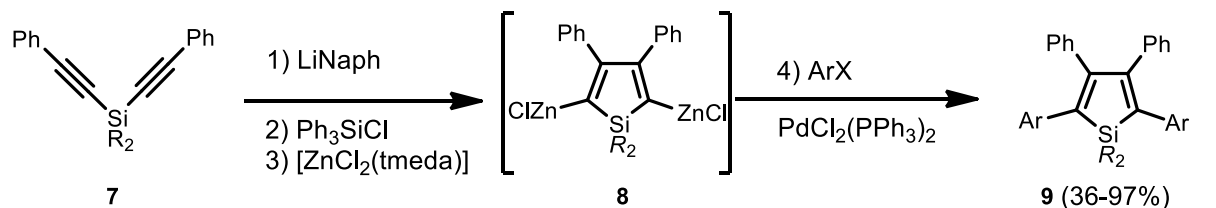

R = *p*-Me<sub>2</sub>N, *p*-MeO, *p*-Me, H, *p*-CF<sub>3</sub>, *p*-NO<sub>2</sub>, *m*-Me, *m*-F, *m*-CF<sub>3</sub>

**Figure 4** Synthesis of symmetric 2,5-diaryl siloles.

The one-pot method for making siloles although easy and efficient does not allow for the fine tuning of their structure and thus the optimization of their physical properties. Modifications to the siloles can only be done to the silyl moiety, as the method described in (**Figure 4**) does not allow for selective coupling at the C2 or C5 positions of the silole. Dissymmetric siloles could serve as an end cap to length specific oligomers or allow the synthesis of silole chromophores with dissimilar functional groups at the C2 or C5 positions.<sup>11</sup> This would provide insight into how chain length affects its thermal, electronic, structural, and thermal properties.<sup>12</sup>

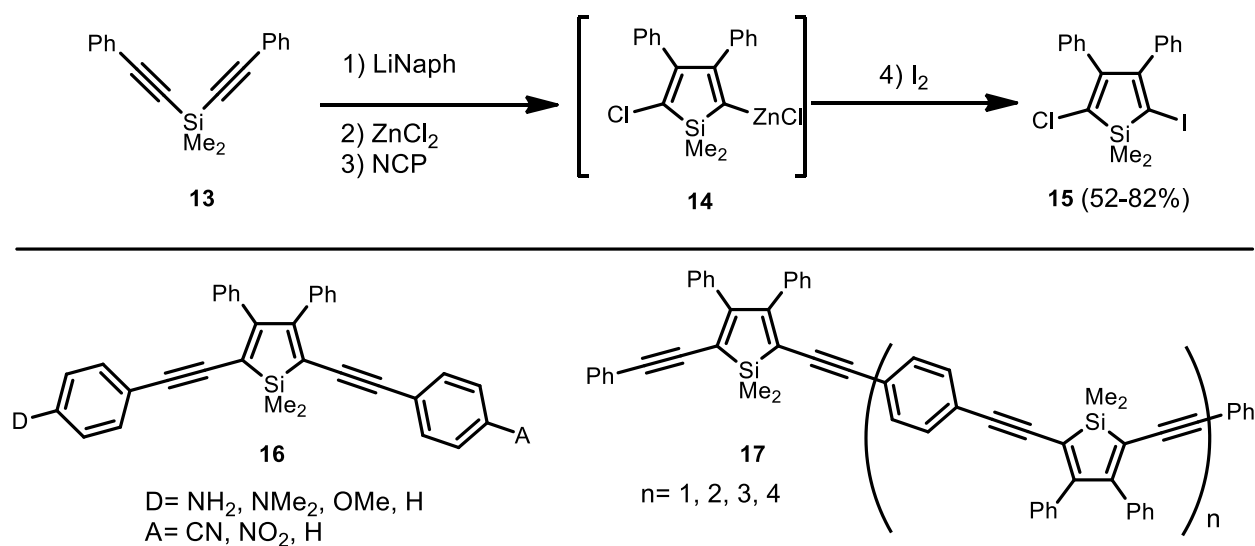
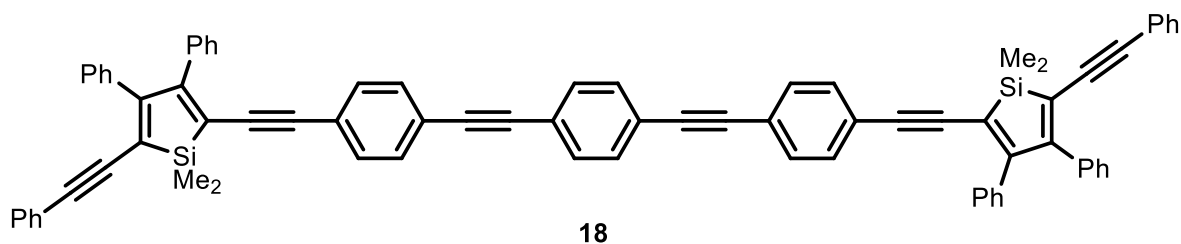

**Figure 5** Dissymmetric donor-acceptor siloles and oligomeric siloles.

The donor-acceptor (DA) siloles proved that increasing the polarity of the siloles sequentially from the parent silole (D = A = H) to more electron delocalized examples (D = NMe<sub>2</sub>, A = NO<sub>2</sub>) provided a bathochromic shift in the absorption spectra from 429 to 496 nm. These results demonstrate that by manipulating the peripheral substituents at the 2,5 position of the silole the electronic and physical properties of the silole can be changed to create DA chromophores. Interestingly the DA groups led to the development of the longest wavelength emission for a single silole chromophore **16** (D = OMe, A = NO<sub>2</sub>).<sup>11</sup> This shows that varying the DA groups results in changes to the photoluminescence spectra. When dealing with oligomers, we see that absorption maxima plateaus at the tetramer silole **17** (n = 4). When comparing the absorption maxima of the low molecular weight oligomer **17** (n = 4 at 492 nm) to Barton's analogous high molecular weight



analogue **5** (494 nm)<sup>6</sup> we can see less than 2 nm difference. These observations demonstrate the effective conjugation length of silole polymers at the tetramer. The quantum efficiencies of silole oligomers turned out to be worse than that of the monomer.<sup>12</sup> The synthesis of silole **18** was done to test the importance of a single silole ring compared to its counterpart silole **17** (n=3). A comparison of these two synthesized compounds show that the absorption and emission wavelengths of compound **18** are blue shifted compared to **17** (n=3), although **18** did have a higher quantum efficiency  $20.11 \times 10^{-2}$  vs.  $0.37 \times 10^{-2}$  for the trimer.<sup>12</sup>



**Figure 6** Extended silole chromophores.

Further work on 3,4-diphenylsiloles with 2,5-arylene ethynylene substituents was done by Ding and coworkers in 2007. This was done to gauge the relationship between the chain length of arylene ethynylene siloles and their quantum yields.<sup>13</sup> It was found that elongation of the arylene ethynylene chain to three aromatic rings improved quantum yields, **21** (quantum yield 50%) enhanced over the previous silole **18** (quantum yield 20%).

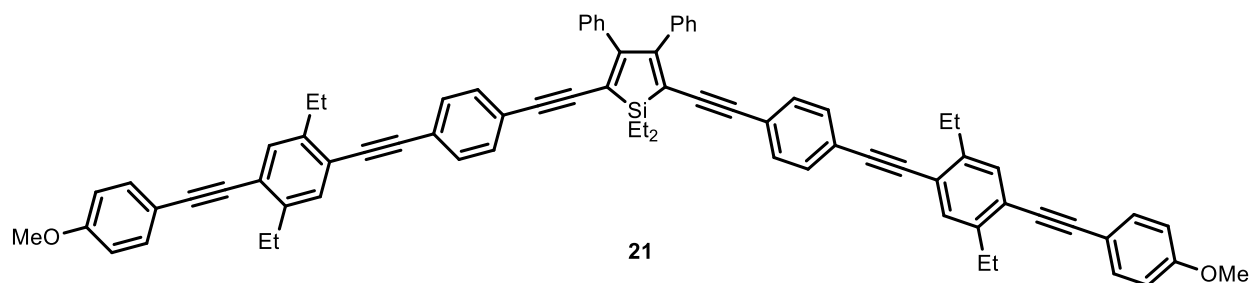

**Figure 7** Highly conjugated phenylene ethynylene substituted siloles.

In addition to functionalization of the 2,5 positions of siloles other methods for increasing photoluminescence (PL) have been researched. Increasing the energy barriers to non-emissive

decay by increasing the steric bulk of the silole substituents is another way to improve the PL. The Pagenkopf group has synthesized modified silole **20** designed to impart rigidity and thus minimize vibrational-rotational events compared to **19** (Figure 7). The results of this study provided the most efficient fully substituted monomeric siloles in solution **20** having a 63% quantum efficiency (referenced to fluorescein).<sup>14</sup> This is compared to **19**, which has a quantum efficiency of 9%, proves the development of a tunable silole scaffold. This led to the examination of the ECL properties of these compounds, where only moderate ECL quantum yields were obtained. The cause of these low quantum yields might be the instability of the radical cations produced for ECL generation.<sup>105</sup>

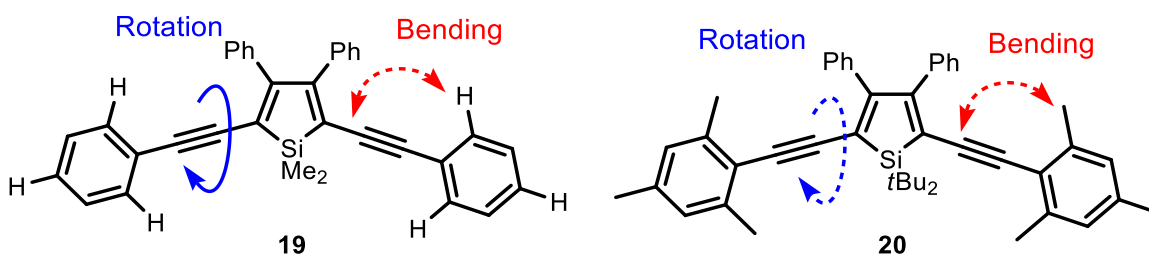

**Figure 8** The steric rigidity of 2,5-arylene ethynylenes.

To further improve quantum yields of 3,4-diphenylsiloles Tamao's silole **12** (Figure 4) was modified at the Si, C2 and C5 positions. As 2,5-bis(bithienyl)silole **22** ( $n = 2$ ) proved to be an efficient electron transporting material we expected that increasing barriers to non-emissive decay would result in enhanced PL and ECL efficiency. This led to synthesizing a series of substituted C2 and C5 bis(thiophenyl) and bis(bithiophenyl) siloles substituted with bulkier silyl groups such as *i*Pr, *t*Bu, and *n*Hex (Figure 9). This would hopefully result in superior electronic properties (UV-vis, PL, ECL) via the stabilization of the electrogenerated radical anions and cations.<sup>15</sup> It was found that generally chromophores with extended conjugation ( $n = 2$ ) showed easier and more reversible conjugation and of these, branched silicon substituents improved properties further. Additionally, the radical cations are much more stable than radical anions as shown in cyclic voltammograms (CVs). The tuning of the thiophene-silole hybrids translated into improved ECL

efficiency with more stable ECL emission than ethynyl substituted siloles **17** and also highlights the potential application of these siloles.<sup>15</sup>

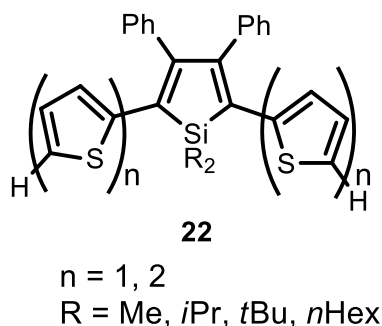

**Figure 9** Thiophene-silole hybrids to tune electrochemiluminescence.

### 1.3 Synthesis of Benzosiloles

Recently the Pagenkopf group has become interested in the synthesis of benzosiloles. A benzosilole is classified as a silole ring fused to a benzene ring, sometimes referred to as silaindenes. Synthesizing benzosiloles was performed partly because the silole synthesis step involving lithium naphthalenide stopped working despite being a known *Org. Syn.* preparation.<sup>16</sup> It was determined that an impurity in the lithium metal used to make lithium naphthalenide was the probable cause of this failure. This impurity caused over reduction of the alkynes (**7**, **Figure 4**), resulting in phenylacetylene and a phenylvinylsiloxane being formed.

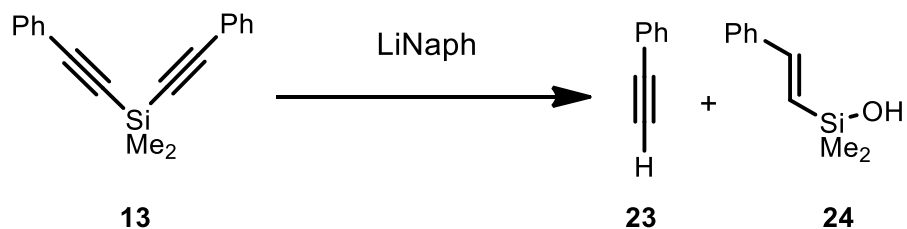

**Scheme 1** Byproducts formed as a result of unknown impurities in the lithium naphthalenide.

An effort was made to move to more reliable chemistry with better known reagents to avoid problems with the LiNaph. Benzosiloles were chosen because of the development of several synthetic methods over the last decade that utilize a variety of different reagents. Using the Pagenkopf groups' expertise in tuning the electrochemical properties of siloles, these synthetic methods would allow the synthesis of new benzosilole chromophores.

Silaindenes have just recently become popular but their diaryl analogues dibenzosiloles (silafluorenes) were first synthesized in 1955, by adding organolithium reagents to dibromobiaryls. These lithiated species are treated with dichlorosilanes to yield dibenzosiloles **26**.<sup>17</sup> The limitations with this method are the extreme reaction conditions needed, and both aryl groups must be identical. The need for a dibenzosilole synthesis that could tolerate asymmetrical phenyl rings led to a new route featuring a palladium catalyzed intramolecular coupling. In this reaction 2-(arylsilyl)aryl triflates **27** are subjected to a palladium catalyzed coupling to provide dibenzosilole **28** in good to excellent yields.<sup>82</sup> This facile synthesis of asymmetric dibenzosiloles has led to their use as orange chromophores in two-colour white-light emitting polymers.<sup>18</sup> These polymers emit white light because they contain an orange light emitting chromophore as the main chain and blue light emitting chromophores as the side chains. These white light polymers have important potential applications in solid state lighting, backlights, colour filters and other lighting applications.<sup>19</sup>

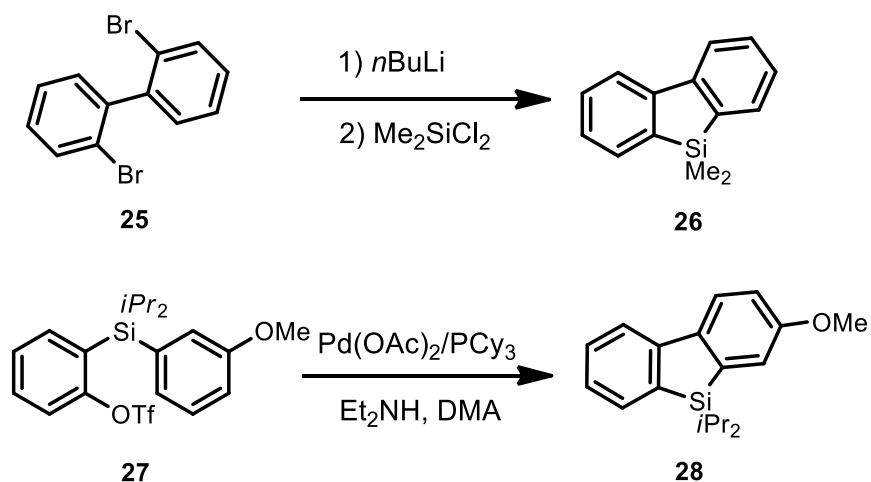

**Scheme 2** Synthesis of symmetric and asymmetrical dibenzosiloles.

In 2002 van Klink and Bickelhaupt discovered that dibenzosilole **26** could be synthesized via catalyzed Si-C bond cleavage.<sup>20</sup> This reaction utilized stoichiometric quantities of an aryl Grignard to cleave a silicon-methyl bond intramolecularly to afford **26**. Building on this work, the Xi group in 2005 reported the synthesis of **26** by using lithium instead of magnesium to cleave Si-C bonds.<sup>21</sup>

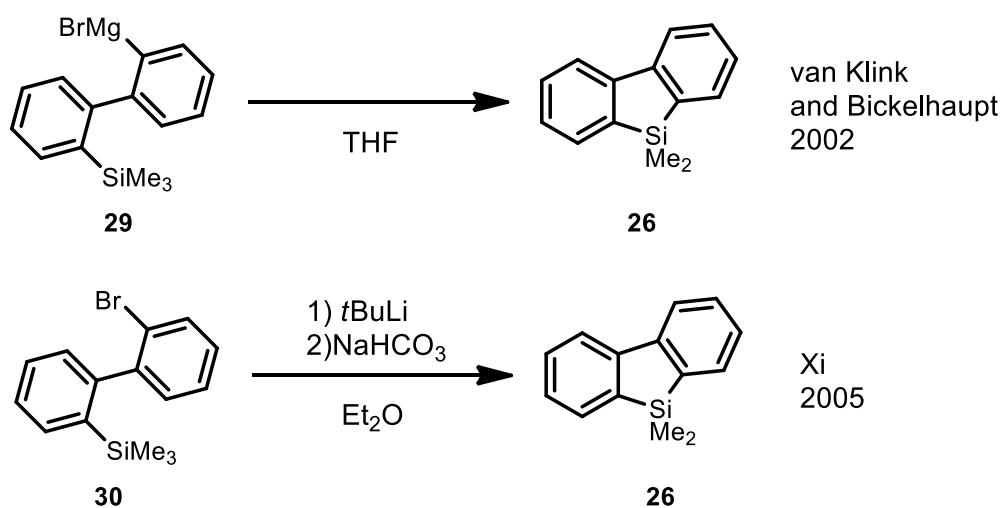

**Scheme 3** Synthesis of dibenzosiloles via metal catalyzed silicon-carbon bond cleavage.

In the last decade there has been a large push to produce benzosiloles because of the applications of benzosilole derivatives such as siloles and dibenzosiloles as chemosensors and light emitting diodes.<sup>39,43</sup> and in 2008 a number of groups came out with new methods for easily synthesizing benzosiloles. One of the first methods for synthesizing benzosiloles was from the Murakami group and proceeded by *trans*-allylsilylation of silicon tethered enynes with a gold(I) catalyst (**Scheme 4**). The gold catalyst activates the alkyne to perform nucleophilic intramolecular attack on the alkene and then rearranges to benzosilole **32**.<sup>22</sup> This reaction was tolerant of substitutions to both the alkyne and allyl moieties. The drawback is that alkenylsilanes are required for the reaction which limits functionalization at the C3-position.<sup>23</sup>

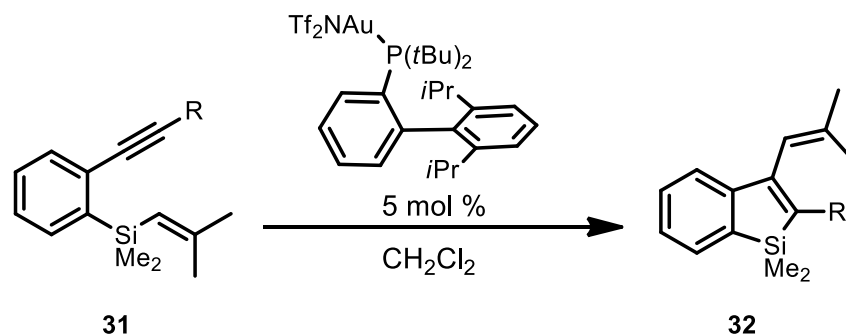

**Scheme 4** Murakami's approach to 3-allylbenzosiloles using a gold catalyst.

In the same year Nakamura's group came out with a synthesis of benzosiloles that employed an intramolecular cyclization of (2-alkynylphenyl)silanes using  $\text{Me}_3\text{SnLi}$  in a tin-mediated cyclization (**Scheme 5**). Electrophiles can then be added to the trialkyltin moiety at the C3 position to allow further functionalization.<sup>24</sup> The applicability of this reaction is limited because it is only reported to work with phenylalkynes.

A year later the Nakamura group developed another strategy based on previous synthesis of various benzoheteroles. The basic idea is a heteroatom ion adds intramolecularly to an alkyne to make benzoheteroles.<sup>25</sup> This proved challenging with silicon because the polarity of the Si-H bond makes ion formation unfavourable.<sup>26</sup> Eventually the Nakamura group found that KH in DME could perform the transformation to synthesize benzosiloles from (2-alkynylphenyl)silane **35**. This base-promoted cyclization tolerated a variety of substituents such as 2-naphthyl and 2-pyridyl. Although this method did display a larger scope, functionalizing the C2 and C3 positions still requires using multiple steps and expensive catalysts.<sup>25</sup>

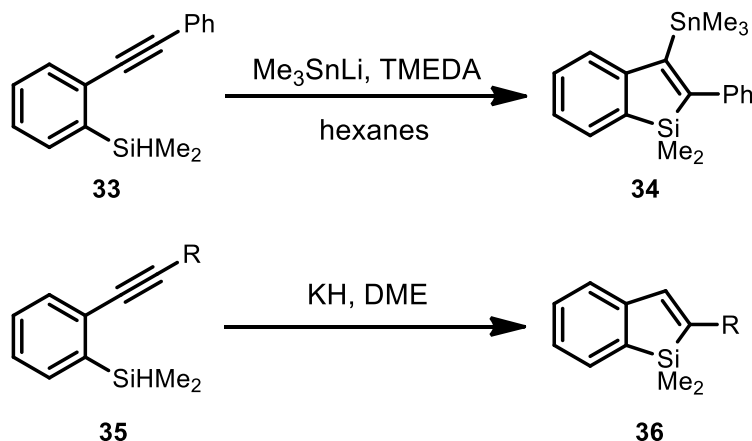

**Scheme 5** Nakamura's routes for benzosilole synthesis.

The first methodology that allowed for extensive substitution on the C2 and C3 positions of the silole came from the Chatani group in 2009. Here they isolated an unexpected product **26** from a reaction of **37** in the presence of hexamethyldisilane and a rhodium catalyst. Instead of trapping an iminoacylrhodium species with aryl chloride **38**, what they got was a trimethylsilyl group replacing the nitrile.<sup>27</sup> The Si-Me bond from the TMS group then was cleaved by the rhodium catalyst to get dibenzosilole product **26**. This cleavage of the silicon-carbon bond using rhodium had only been reported once previously, but this unique reactivity had not been explored.<sup>28</sup>

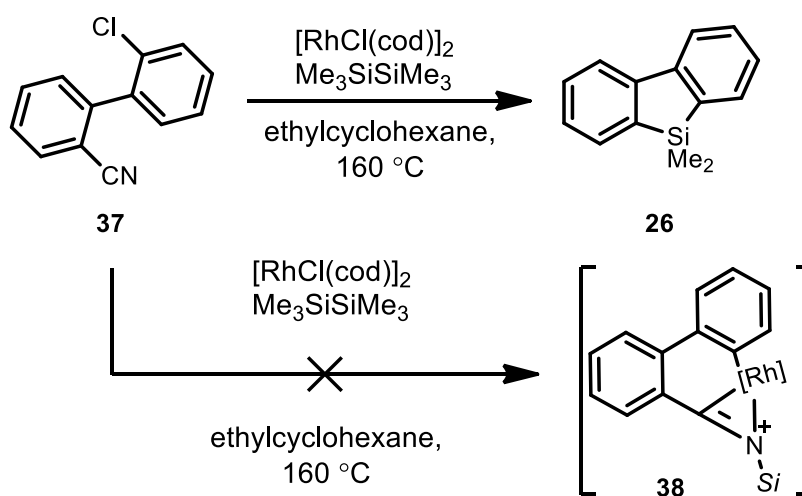

**Scheme 6** Chatani's initial dibenzosilole synthesis.

The result of this discovery was a new methodology to synthesize benzosiloles. The optimized procedure for this reaction utilizes a rhodium catalyst to couple 2-trimethylsilylphenylboronic acid **39** with alkynes via catalytic cleavage of the carbon-silicon bond.<sup>29</sup> This reaction was found to tolerate a number of alkynes including those with aryl, alkyl, and asymmetric substituents in excellent to moderate yields. Also, varying silyl substituents were used such as triethylsilyl, isopropyl dimethylsilyl, and phenyldimethylsilyl. The reaction was also performed in relatively mild conditions to allow for larger functional group tolerance over previous synthetic methods. Discovery of Chatani's benzosilole synthesis (**Scheme 7**) led to the idea of taking the Pagenkopf group's knowledge of siloles and applying it to benzosiloles.

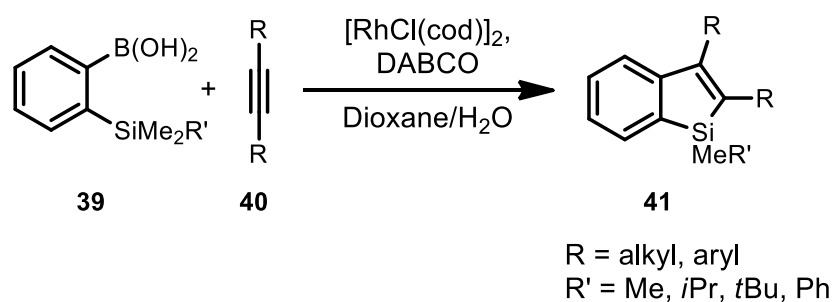

**Scheme 7** General reaction for Chatani's benzosilole synthesis method.

In 2013 computational chemistry by Yu and coworkers was done to better understand the mechanism of this reaction. The reaction begins with the transmetalation of the generated hydroxyrhodium species and 2-trimethylsilylphenylboronic acid, to give intermediate **44**. Subsequent alkyne insertion affords **44**, which is proposed to undergo an oxidative addition to yield Rh(III) intermediate **45**. This is followed by reductive elimination to give the product **46** and a methylrhodium species which is regenerated back into the hydroxyrhodium species with stoichiometric water (**Scheme 8**).<sup>30</sup>



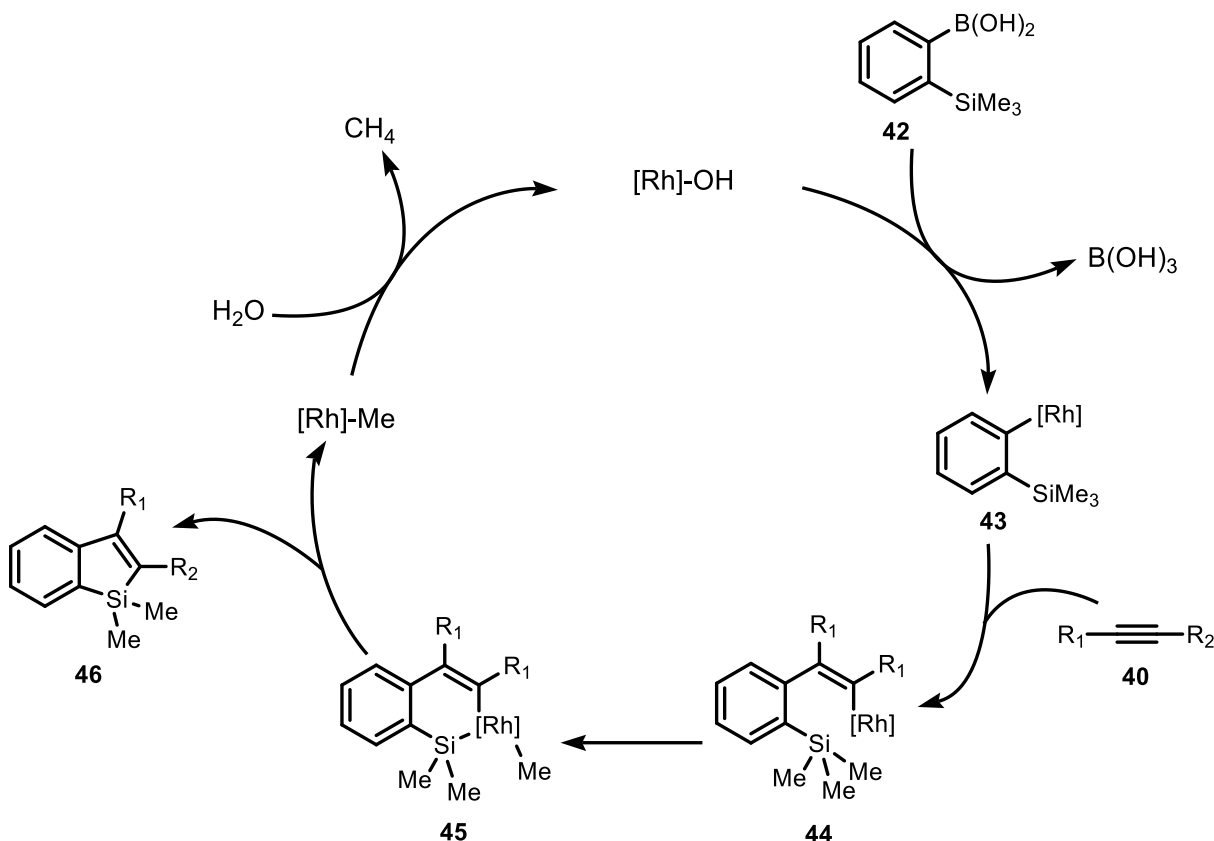

**Scheme 8** The catalytic cycle for the formation of benzosiloles with  $[\text{RhCl}(\text{cod})]_2$ .

## 1.4 Applications of Siloles

Recently siloles have been utilized in the construction of electroluminescence devices such as biological probes<sup>31,32</sup> and chemosensors.<sup>33</sup> This is partly due to the discovery of a novel phenomenon in siloles: aggregate induced emission (AIE).<sup>34</sup> The siloles change from weak fluorophores in solution to strong emitters in the condensed phase contrary to the quenching that occurs in conventional fluorophores. Studies have proven the cause of this strong fluorescence is the restriction of intramolecular rotation.<sup>35,36</sup> In solution the intramolecular rotation serves as non-radiative relaxation pathway, but this is restricted in the aggregated state where rotation is restricted due to tight molecular packing. It was found in a study done by Tang and coworkers that substitution at the 3,4 positions of the silole does contribute to AIE, but it is the 2,5 positions of the silole that effects emission wavelength and molecular conjugation.<sup>37</sup>

This aggregate induced emission effect has found a number of important applications in the past few years. Zhang and Zhu<sup>33</sup> for example, have utilized siloles with AIE properties for the detection of DNA. They use 2,3,4,5-tetraphenylsiloles with a quaternary ammonium moiety (**47**) which aggregates upon addition of DNA, increasing the fluorescence of the solution. This occurs because of the electrostatic interactions between the ammonium cation and the anions of the phosphate backbone of DNA. This can be seen in (**Figure 10**) where positive charge represents the silole cation and the negative charge represents the phosphate anion. This allows the siloles to be used as a label-free fluorescence assay for nuclease S1 activity and nuclease inhibitor screening. This system has potential use in drug discovery where high-throughput screening of nuclease inhibitors is of great importance.

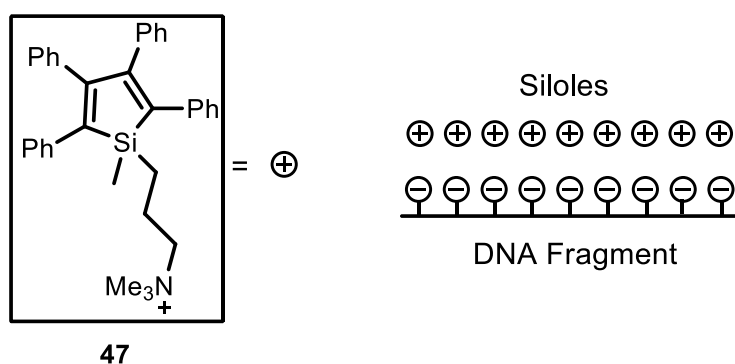

**Figure 10** Illustration of fluorescence detection of DNA with AIE-active silole.

Siloles have also found applications as fluorescent detectors of cyanide. Cyanide is one of the most toxic anions, harmful to both humans and the environment, despite this cyanide salts are still utilized in gold mining and metallurgy.<sup>38</sup> Although there is strict monitoring and control, in most countries the accidental release of cyanide does occur. Therefore, it is desirable to have a sensitive and selective chemical sensor for cyanide, and even though fluorescent and non-fluorescent sensors for cyanide exist fluorescence turn-on detection is still rare. Zhang and Zhu have also reported the fluorescence turn-on detection of cyanide utilizing silole **47**.<sup>39</sup> The sensor turns on upon the nucleophilic addition of cyanide to a trifluoroacetyl amino compound **48**, yielding **49** an amphiphilic species which would induce aggregation of the silole through electrostatic interactions and as a result the fluorescence of the

ensemble largely increases. This system displays selectivity over other anions such as fluoride or acetate and further optimization of the ensemble is underway to improve its sensitivity.

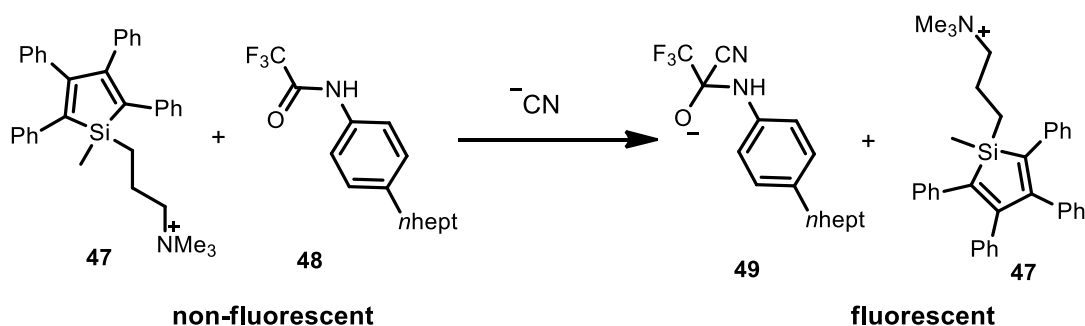

**Scheme 9** Use of siloles as a fluorescence turn on detector of cyanide.

Alternatively, siloles have also been looked at as light emitters for organic light-emitting diodes (OLEDs). The potential use of siloles in OLEDs stems from the fact that many conventional luminophores suffer from quenching caused by aggregation in the condensed phase. This aggregation-caused quenching (ACQ) has been an obstacle to the advancement of OLEDs because most light emitters have to be solid films when used in devices.<sup>40</sup> The incorporation of siloles exhibiting the AIE phenomenon into OLEDs results in efficient OLEDs without the need for complicated and hard-to-control doping processes. In work done by Zhao and Tang<sup>41</sup> they utilized 2,3,4,5-tetraphenylsiloles modified with dimesitylboryl groups to create a bifunctional material **50** for use in OLEDs. These siloles are designed to act both as an electron transporting material and as a light emitting material in OLEDs. This eliminates the need for separate light emitting and electron transporting layers in OLEDs, which simplifies the device configuration and lowers the cost. In addition, the OLEDs show increased electroluminescence efficiency over the standard triple layer OLED designs. This improvement can be attributed to the incorporation of the electron deficient dimesitylboryl group into AIE active 2,3,4,5-tetraphenylsiloles, this improves the materials electron affinity and its electron transporting ability.

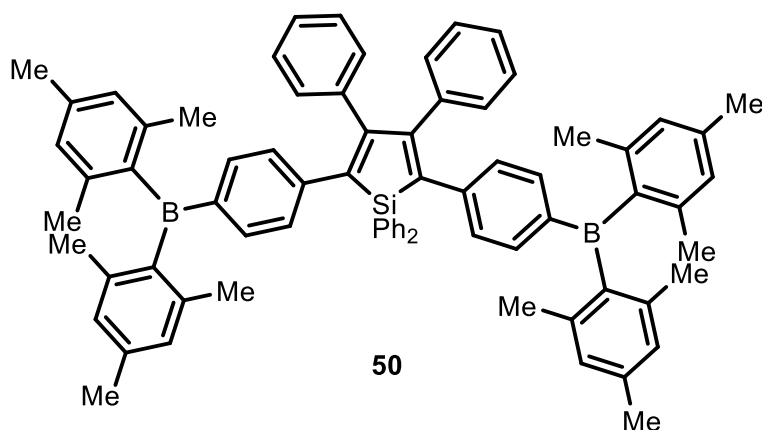

**Figure 11** Modified AIE-active 2,3,4,5-tetraphenylsilole for use as a bifunctional material in OLEDs.

Silole frameworks have also made their way into sensors for nitroaromatic explosives. These sensors for detecting explosive residues are of great importance because the environmental and personal health risks associated with these compounds. Polymers of tetraphenylsilole have been developed into chemical sensors for the detection of nitroaromatic explosives.<sup>42</sup> These polymers are about 10-16 units long and detection is based on photoluminescence quenching of these silole oligomers via intercalation of nitroaromatic compounds. Siloles have also be used to detect explosives by being incorporated into heteropentacenes (**Figure 12**).<sup>43</sup> These compounds fluoresce strongly under normal conditions but fluorescence is quenched in the presence of nitroaromatic explosives such as trinitrotoluene (TNT).

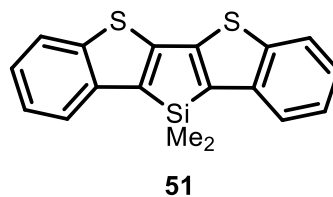

**Figure 12** Structure of silole based nitroaromatic explosive sensor.

Efficient white organic light-emitting devices have also been made from silole containing polymers. Green-emitting and red-emitting siloles moieties have been incorporated into the

blue-emitting fluorene and carbazole copolymer backbone to create effective white OLEDs, which could have potential applications in display and illumination technology.<sup>44</sup>

Additionally, siloles that act as chemoselective sensors for the detection of chromium(VI) in drinking water has also been reported. Trogler and coworkers have reported a luminescent silole sensor for chromate via functionalization of 2,3,4,5-tetraphenylsilole with allylamine.<sup>45</sup> These siloles exist as nanoparticles in aqueous solutions and preferably bind chromate over other oxoanions via hydrogen-bonding of the amine functionality.

Siloles have also been incorporated into dye-sensitized solar cells, where they have been utilized as spacers in triarylamine based sensitizers **52**.<sup>46</sup> The advantage to using these sensitizers is the easier preparation and lower cost than other common ruthenium based dyes. The triarylamine sensitizers use dithienosilole because of its low-lying LUMO energy levels and its fast electron mobility. This allows the effective injection of electrons into the TiO<sub>2</sub> conduction band of the solar cell.

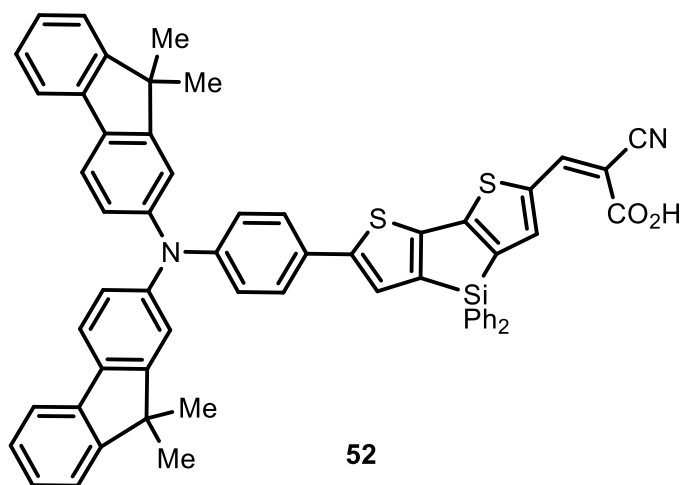

**Figure 13** Triarylamine based solar cell sensitizers including the dithienosilole moiety as a spacer.

Highly fluorescent compounds are also used as fluorescent probes and tags. These fluorescent molecules are used often in biological research because of their versatility and their sensitivity. These probes have a wide variety of uses in clinical and biomedical diagnosis including monitoring biological processes, and protein labelling.<sup>47</sup> Fluorescent probes also have the

advantage of being less dangerous to work with than their radioactive alternatives.<sup>48</sup> Fluorescent probes and tags designed specifically for ECL-based analytical methods should include only one binding site. This allows the molecule to be selectively coupled to single-stranded DNA or antibodies among others. Fluorescent probes are coupled via efficient routes including amide coupling,<sup>49</sup> click reaction,<sup>50</sup> or using activated esters.<sup>51</sup> The coupling for this project is to be done by attaching amines to the fluorophore to form amides (**B**). The coupling amines with carboxylic acids in the presence of carbodiimides has been done efficiently with a variety of proteins in mild conditions.<sup>49</sup> The benefits of amines over other coupling strategies is the nucleophilicity of an amine, the strength of the amide bond, and that amines can also be protected or created from other functional groups such as nitriles. The azide coupling (**A**) and the activated ester (**C**) could also be derived from nitriles but this would take several steps and reduce the overall yields.

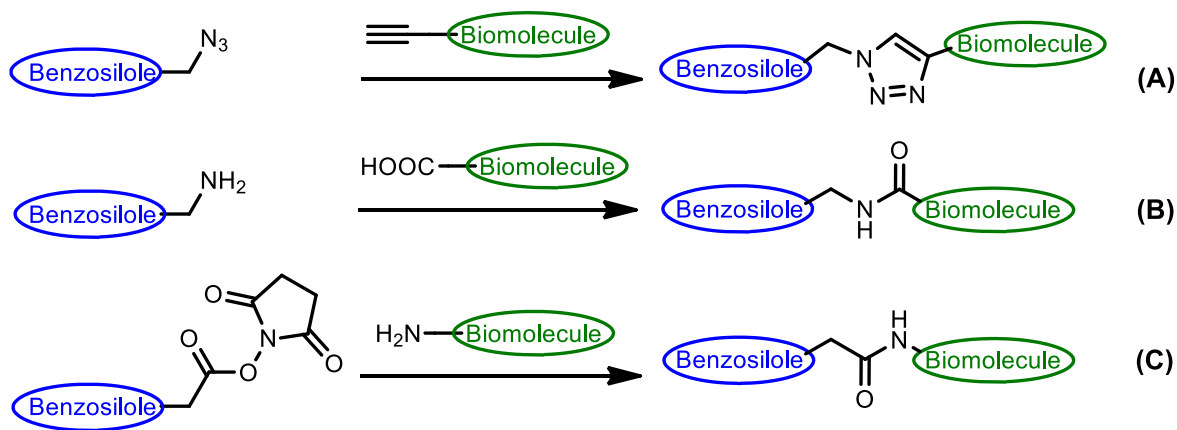

**Scheme 10** Linking of benzosilole chromophore to a biomolecule.

The goal of this project is to synthesize a series of thiophene substituted benzosiloles to act as efficient ECL fluorophores. These fluorophores would then be coupled to biomolecules so they can be tracked during ECL experiments. This could occur by appending a functional group to the phenyl ring of the benzosiloles that could transform into an amine, allowing coupling with biomolecules (**Scheme 10**).

## 2.0 Results and Discussion

### 2.1 Synthesis of 2-Silylphenylboronic Acids

The first step in the synthesis of benzosiloles starts by synthesizing 2-silylphenylboronic acids (**Scheme 11**). This project was first undertaken briefly by former Pagenkopf group members A. Stevens and B. Machin who successfully synthesized a number of intermediates and substrates that provided a starting point to work from. The key goal initially was to identify a route to synthesize large quantities of 2-trimethylsilylphenylboronic acid **55** easily and efficiently. Starting from 1,2-dibromobenzene **53** in THF/Et<sub>2</sub>O and adding 1 equivalent of *n*-butyllithium at -110 °C to effect lithium halogen exchange, followed by trapping with chlorotrimethylsilane afforded 2-bromotrimethylsilylbenzene **54**. This crude material would then be distilled to improve product purity. This reaction caused problems initially, specifically the cold temperatures with which this reaction must proceed. Maintaining -110 °C ethanol bath for 5 hours at a time proved to be difficult and any deviation in temperature caused drastic reductions in yield. The other important thing is to employ constant stirring when the appropriate temperature is reached to ensure a uniform cold bath and failing to do this resulted in a drop in yield. It is these factors that caused the isolated yield only be 18%, almost half of that reported.<sup>29</sup>

The subsequent reaction involved another lithium halogen exchange followed by addition of triisopropyl borate at -78 °C (**Scheme 11**). The solution was then hydrolyzed with 1 M HCl to acquire the desired 2-silylphenylboronic acid **55**. The problem with this reaction is that the hydrolysis does not go to completion and a viscous mixture of boronic acid and isopropyl borate is recovered. Both the use of stronger acids or higher concentrations did not improve the effectiveness of the hydrolysis nor did longer periods of stirring time. Frequently the product **55** would start to decompose upon addition of stronger acids and attempts to purify the crude product via column chromatography failed. When solid was recovered from the reaction it was fairly simple to purify by recrystallization from hexanes. The issues with hydrolysis lowered the yields of an already inefficient reaction, which made scaling up the reaction difficult. These two low yielding steps plus troubles in purification of these chemicals led to search for a more effective route for synthesizing 2-silylphenylboronic acids.

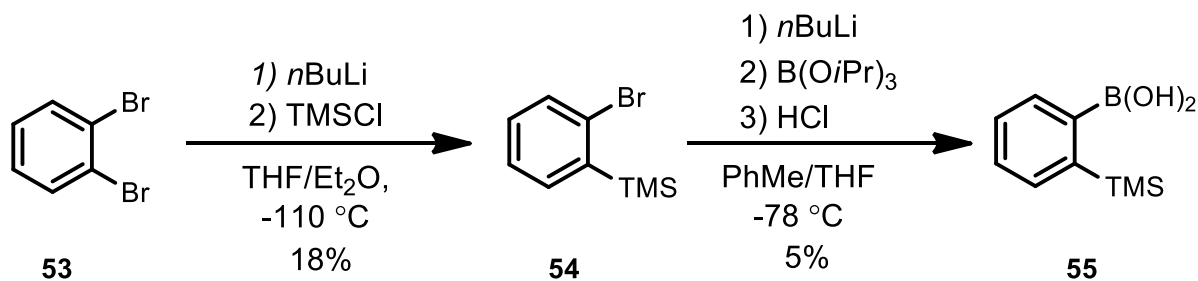

**Scheme 11** The synthesis of 2-trimethylsilylphenylboronic acid from 1,2-dibromobenzene.

A number of new methods were considered to achieve 2-silylphenylboronic acid including a gold catalyzed halogenation of aromatic boronates, but a lack of *ortho* selectivity meant it was ruled out.<sup>52</sup> The focus was then turned to directing groups that could introduce silanes to a benzene ring in the *ortho* position. The first *ortho* directing strategy utilized a removable directing group attached to an aryl boronic acid. The directing group consisted of 2-pyrazol-5-ylaniline (pza-H<sub>2</sub>) **57** that could be attached to a boronic acid, to allow a variety of silanes to be added *ortho* to the arylboronic acid in the presence of a ruthenium catalyst, with norbornene as a hydrogen scavenger.<sup>53</sup> It was decided not to pursue this synthetic method further because the synthesis was deemed too lengthy and more promising synthetic routes to 2-silylphenylboronic acids were chosen.

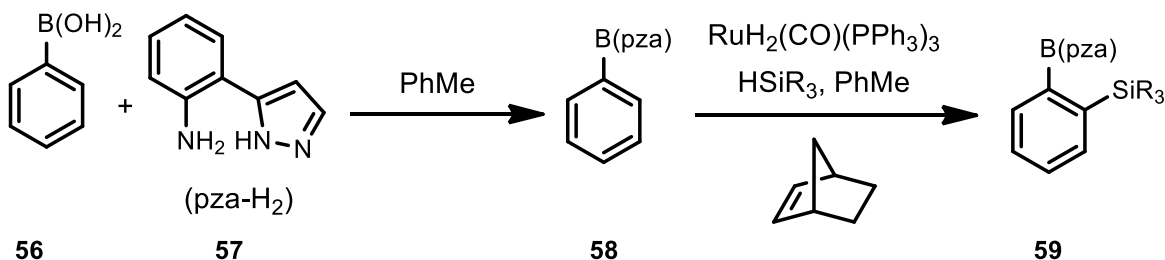

**Scheme 12** *ortho*-Directing agent for ruthenium-catalyzed aromatic C-H silylation.<sup>53</sup>

The next method involved a directed *ortho*-lithiation with *O*-aryl carbamates.<sup>54</sup> The carbamate **62** is made by the acylation of phenol with diethylcarbamoyl chloride and sodium hydride as the base. This carbamate is then used to *ortho*-direct lithiation with *sec*-butyllithium in the presence of tetramethylethylenediamine (TMEDA). The benefit of these reactions was the



access to 2-silylphenyldiethylcarbamates which would hopefully react similarly to 2-silylphenylborates **55** in the presence of the rhodium catalyst and an acetylene to give the product **64** (Scheme 13). The inspiration for this comes from work done by Garg and coworkers who used a variety of iron and nickel catalysts in Suzuki-Miyaura couplings on phenyl carbamates. Garg discovered that he could cleave carbamates by adding iron or nickel catalysts and upon addition of alkyl Grignards, amines, or aryl groups he could create a library of compounds.<sup>55</sup> Although the reaction proposed has not been reported, the prospect of the reaction working would give us access to the desired compounds (**64**) faster and more efficiently. The reaction with *sec*BuLi though did not work and only 2% product was recovered. The reaction was attempted using THF stored over sieves, with distilled TMSCl and finally with freshly distilled TMEDA, all with no result. Work stopped on this project to move towards more straight forward approaches with literature precedence.

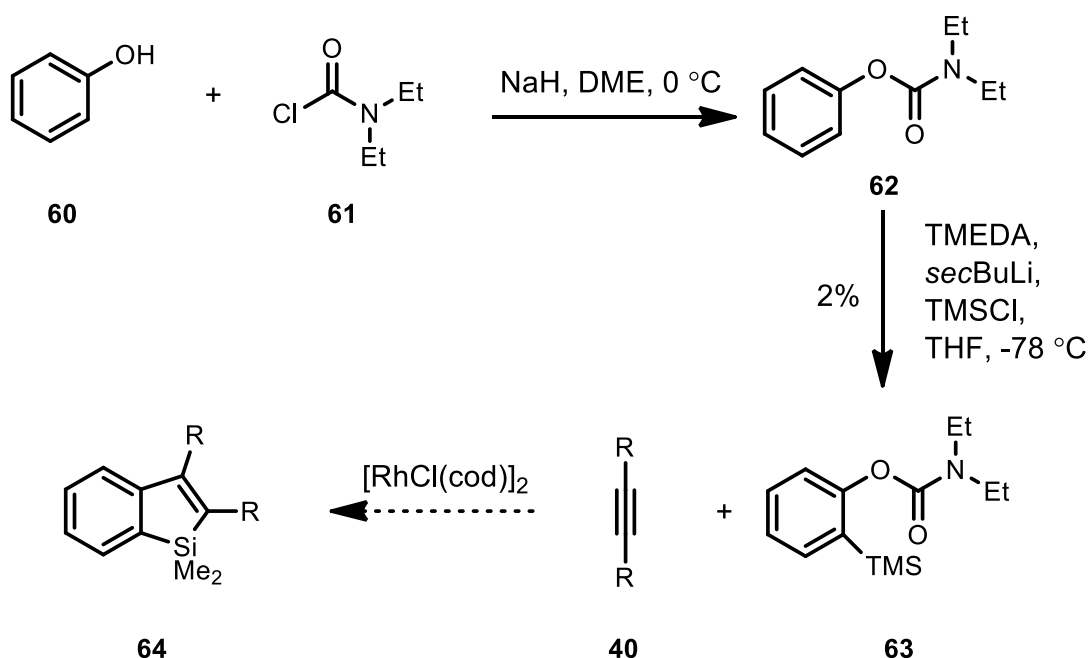

**Scheme 13** Synthetic routes to benzosiloles using *ortho*-directing carbamates.

The next strategy was to use 1,2-diiodobenzene **65** and convert it to the pinacol boronate **67** followed by treatment with isopropyl Grignard lithium chloride complex (turbo Grignard).<sup>73</sup> The addition of lithium chloride to the isopropyl Grignard facilitates Br/Mg-exchange with aryl

bromides because of the higher nucleophilicity of turbo Grignard. The resulting aryl Grignard was then treated with chlorotrimethylsilane at  $-78\text{ }^{\circ}\text{C}$  to yield the desired intermediate **68**.<sup>56</sup> These magnesiated phenylboronic esters are shown to have good reactivity with a variety of electrophiles in excellent yield when also in the presence of a catalytic amount of a lithium chloride/copper cyanide species. The reaction of diiodobenzene with methoxy-tetramethyl-dioxaborolane **66** in the presence of isopropyl magnesium chloride yielded the desired pinacol protected phenylboronic acid in a 93% yield **65**. The isopropyl Grignard was then introduced to this product to give the *ortho*-magnesiated phenylboronic ester, which was then transmetalated with copper cyanide, followed by treatment with TMSCl to give the product in a 13% yield (**Scheme 14**). This low yield could partly be explained by the lower reactivity *ortho*-magnesiated phenylboronic esters are known to display as compared to the meta or para analogues. Despite having some success with this route, the low yields in the last step led to the abandonment of this route.

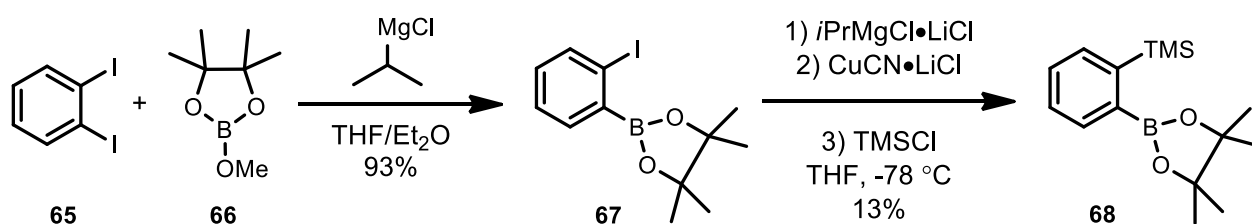

**Scheme 14** Synthesis of 2-silylphenylborates from 1,2-diiodobenzene utilizing isopropyl Grignard.

The final strategy to access 2-trimethylsilylphenylboronic acid used a protected phenylboronic acid followed by installation of the trimethylsilyl group *ortho* to this borate (**Scheme 15**). The synthesis started from 2-bromophenylboronic acid which was esterified with *N*-butyldiethanolamine (BDEA) by stirring in toluene ( $\text{PhMe}$ ) at  $50\text{ }^{\circ}\text{C}$  for 1 h. Following evaporation of the solvent the product was triturated to increase purity.<sup>57</sup> The next involved cooling to  $-90\text{ }^{\circ}\text{C}$  and adding a solution of **71** to a solution of  $n\text{BuLi}$ . Following stirring for 20 minutes,  $\text{TMSCl}$  was added and then 1 M  $\text{HCl}$  was added an hour later. Attempted purification by trituration led to only phenylboronic acid being recovered and column chromatography was challenging as the boronic acid would streak on the column. Product was achieved by putting the crude mixture onto a silica plug and flushing with non-polar solvents followed by 100% ethyl acetate. The yield in this

reaction was only 37%, probably due to the presence of unhydrolyzed product sticking to the silica gel. Optimization was not performed on this reaction because enough of the 2-trimethylsilylphenylboronic acid had been synthesized for future reactions.

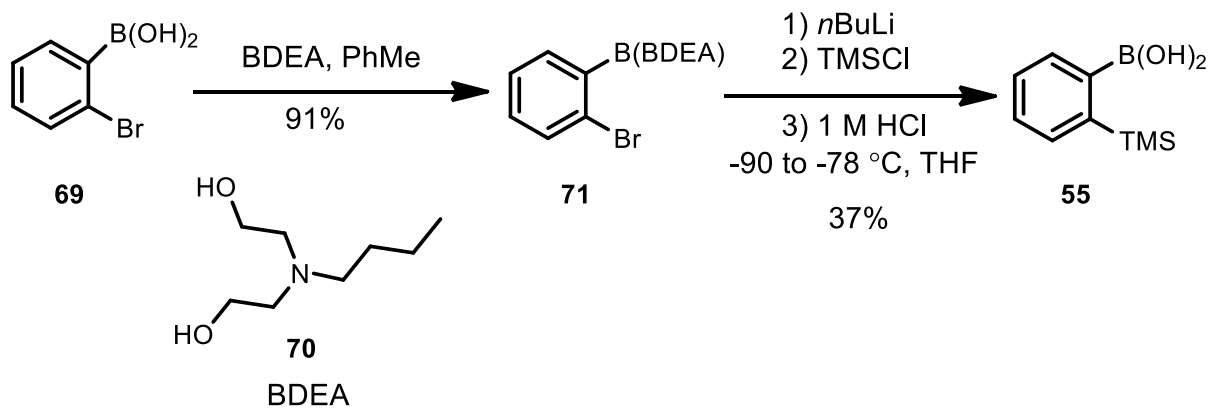

**Scheme 15** The synthesis of **55** using BDEA as a protecting group followed by lithiation and TMSCl trapping.

## 2.2 Synthesis of Thiophene Acetylene Species

Thiophenes were chosen to couple to benzosiloles because of the past success in synthesizing siloles containing oligothiophenes at the C2 and C5 position, which display efficient ECL properties.<sup>15</sup> In addition, thiophenes have recently seen an upsurge in popularity to become the most frequently used  $\pi$ -conjugated materials particularly in organic electronic devices.<sup>58</sup> This includes the use of oligothiophenes in organic light emitting diodes (OLEDs),<sup>59</sup> in organic solar cells (OSC),<sup>60</sup> chemosensors,<sup>61</sup> and biosensors.<sup>62</sup> The success of thiophenes in these areas can be attributed to the ease of synthesis using transition metal catalysts and also their novel optical and electronic properties.<sup>63</sup>

Having synthesized 2-silylphenylboronic acids, thiophenes linked by acetylenes were needed for use in the rhodium catalyzed cycloaddition reaction. This necessitated the synthesis of various C2 brominated oligothiophenes to couple to (trimethylsilyl)acetylene (TMSA) in a Sonogashira reaction. The synthesis of oligothiophenes was accomplished by a two-step procedure

involving a Kumada coupling followed by halogenation reaction. The Kumada reaction was used because of the simplicity of the reaction as it employs an aryl Grignard which is made from bromothiophenes in the presence of magnesium.<sup>64</sup> This gives this method an advantage over other reactions such as the Suzuki or Negishi couplings which require the synthesis of aryl boronic acids or zinc intermediates respectively.<sup>65</sup>

The synthesis of bithiophene was performed by adding a thiophene Grignard to a solution of 2-bromothiophene and  $\text{NiCl}_2(\text{dppp})$  ((diphenylphosphino)propane) at 0 °C. The solution was then heated to reflux overnight and dilute acid was added to stop the reaction. Purification via column chromatography gave the product bithiophene **74** with good yields (up to 92%). Terthiophene **77** was synthesized by the same method except adding 2 equivalents of thiophene Grignard to commercially available 2,5-dibromothiophene. Brominating bithiophene was performed by adding the product to DMF and *N*-bromosuccinimide (NBS) and stirring overnight. Purification was performed with a short silica gel column to give **75** in 73% yield as a lime green solid.

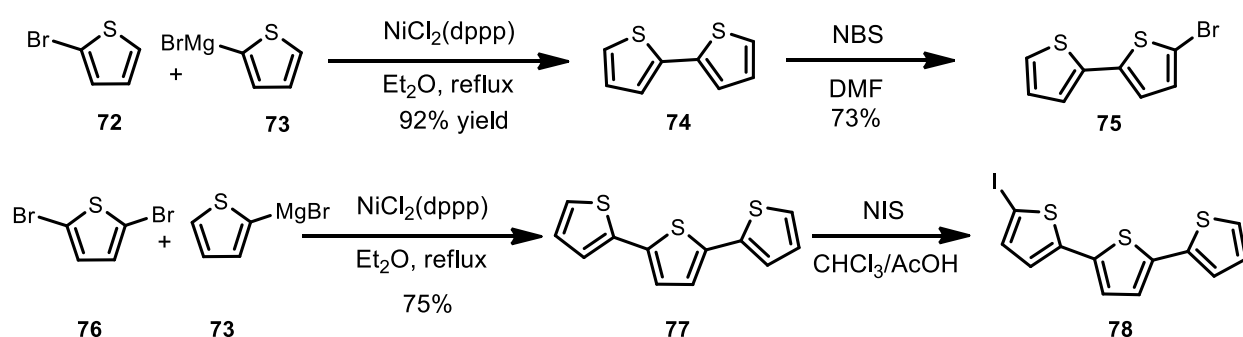

**Scheme 16** Synthesis of oligothiophenes.

The halogenation of terthiophene proved to be more challenging than initially thought and is summarized in **Scheme 17**. When terthiophene is treated with NBS in DMF (*Halogenation 1*, **Scheme 17**) the result is a mixture of products including starting material, 2-bromoterthiophene and 2-5'-terthiophene. All of these products have roughly the same polarity and are therefore inseparable using column chromatography. Purification by recrystallization was also attempted with multiple solvent systems with no success. The lack of difference in polarity is also believed to be the reason for the creation of the dibrominated product, as NBS will brominate 2-

bromoterthiophene just as fast as it will brominate terthiophene. This dibrominated terthiophene contaminates severely complicates the Sonogashira reaction leading to the formation of oligomers and polymers.

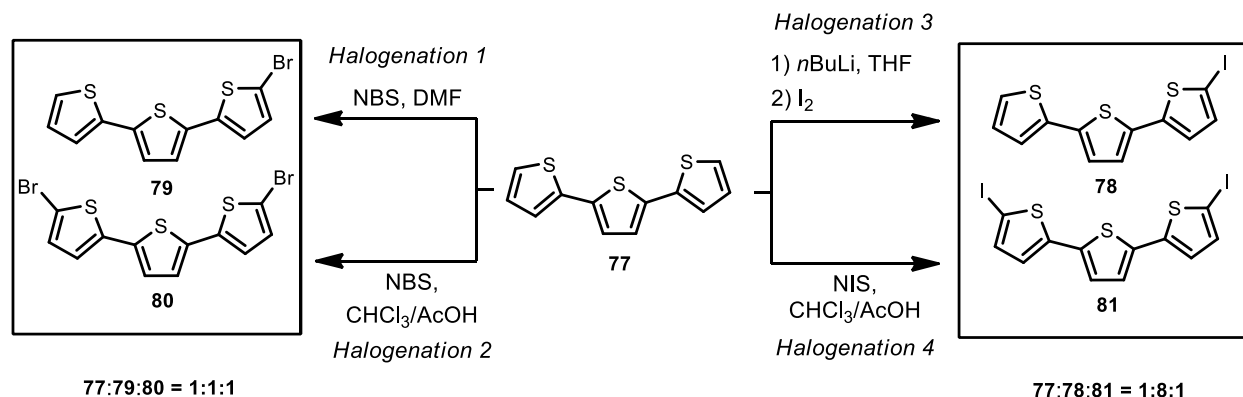

**Scheme 17** Various routes for synthesizing haloterthiophenes.

This led to the development of other strategies to perform selective monohalogenation terthiophene. The solvent system was subsequently switched to  $\text{CHCl}_3$  and acetic acid (AcOH) which was reported to improve selectivity,<sup>66</sup> but ultimately only resulted in only minor increases of product **77** (*Halogenation 2*, **Scheme 17**).

At this stage it was decided to halogenate with iodine instead of bromine because the literature shows greater selectivity with iodine. The new synthesis consisted of adding *n*BuLi to a solution of terthiophene in THF at  $-78^\circ\text{C}$  followed by addition of an  $\text{I}_2$  solution (*Halogenation 3*, **Scheme 17**).<sup>67</sup> Utilizing iodine reduced the amount of the diiodinated product **81** and increased the amount of the desired compound **78**. The downside of this method is that 2-iodoterthiophene is not as soluble as the 2-bromoterthiophene, which results in increased purification time and lower yields. Additionally, halogenation done on terthiophene is very light sensitive and one or two minutes of incidental light will cause drastically reduced yields.

Although this method showed improvement, the inconsistency of the reaction combined with the time intensive purification led to the final strategy (*Halogenation 4*, **Scheme 17**). The solvent system was changed back to  $\text{CHCl}_3/\text{AcOH}$  and *N*-iodosuccinimide (NIS) was used instead of NBS.<sup>68</sup> The reaction with NIS has the benefit of being an easier reaction to set up and also

slightly speeds up purification time by using 1:1 Et<sub>2</sub>O/hexanes as column chromatography eluents. In none of these methods could pure 2-haloterthiophene be isolated because the product was always contaminated with over 10% 2,5'-dihaloterthiophene.

The Sonogashira reaction was initially performed via a 3-step process involving 2 Sonogashira reactions and a deprotection (**Scheme 18**). In the synthesis of **84**, 2-bromobithiophene (**73**), Pd(PPh<sub>3</sub>)<sub>4</sub>, CuI, and (trimethylsilyl)acetylene was added to triethylamine and heated at reflux.<sup>69</sup> After column chromatography the product was treated with potassium carbonate in THF/MeOH to deprotect the TMS group yielding **84**. The last Sonogashira reaction was performed identically to the first, except using **84** as the acetylene source to yield the desired product **85** as the final product. These steps all proceeded with good yields with the first Sonogashira reaction proceeding in higher yields than the last Sonogashira reaction while the deprotection works at >95% yield.<sup>70</sup> It was then found that this three-step procedure could be shortened to 1 step by modifying the Sonogashira reaction by switching the solvent to toluene and utilizing 6 equivalents of DBU (1,8-diazabicyclo-5,4,0-undec-7-ene) as the base.<sup>71</sup> This procedure was proven to be 2 steps shorter than the previous methods and with comparable overall yields.

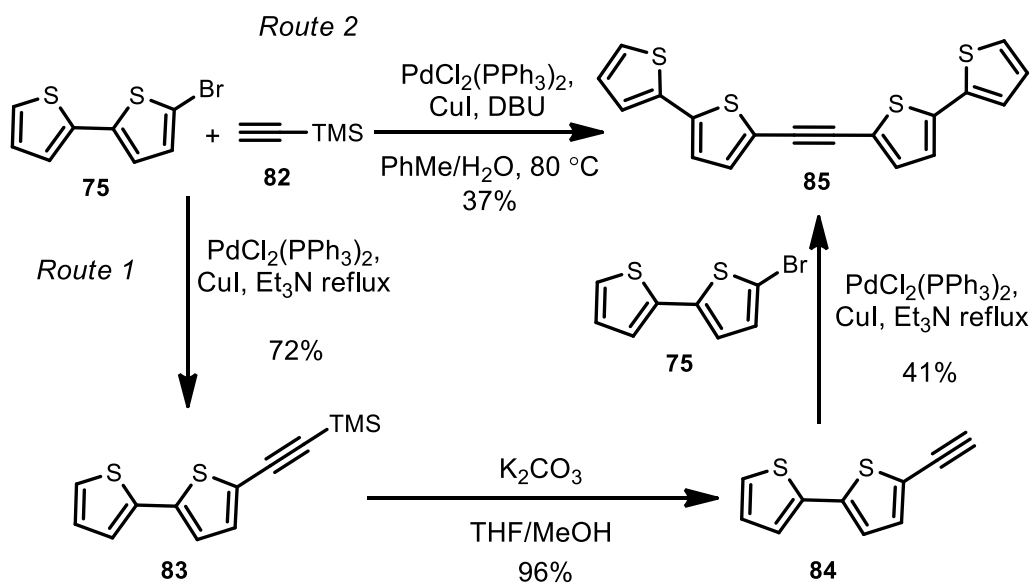

**Scheme 18** The two routes to synthesize di(thiophene)ethynes.

The 1,2-di(thiophene)ethyne **86** was made from commercially available 2-bromothiophene accessed via the Sonogashira reaction *Route 2* (**Scheme 18**). The synthesis of the last product in the series **87** proved to be the most challenging because of problems purifying 2-haloterthiophenes. The contaminant of 2,5'-dihaloterthiophenes would cause polymers and oligomers to form which would drastically reduce yield. In order to avoid polymerization, *Route 1* (**Scheme 18**) of the Sonogashira reaction was chosen with the hopes that the two major byproducts could be separated via column chromatography. Unfortunately, both resulting terthiophene products were inseparable by silica column chromatography and further deprotection of the TMS group with  $K_2CO_3$  led to quick decomposition.

Ultimately *Route 2* emerged as the most promising route as modifications were made in an attempt to improve selectivity. Performing the reaction in toluene instead of benzene and performing the reaction at room temperature or at 80 °C all resulted in equally poor yields. It was discovered that by utilizing a short silica gel column with a polar 3:1 dichloromethane/hexanes eluent system that product could be attained. The product once recovered should be used immediately as the product is unstable in air and light. This meant that the product was not purified or characterized. This is in accordance with previous literature, where this product has been synthesized but only mass spec data is presented because it readily decomposes.<sup>54</sup> This makes the synthesis of the associated benzosiloles **108** and **111** especially difficult because the previous 2 steps must be done without purification on reactions that are low yielding, with material that is air and light unstable. It is only with the completion of the reaction in (**Scheme 7**) that the success of the sequence can be determined.

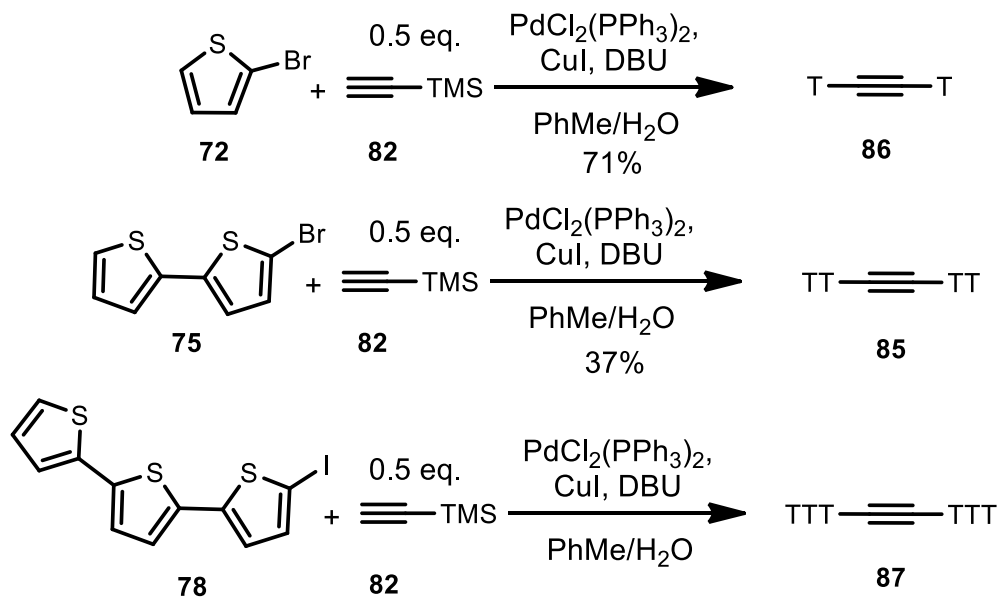

**Scheme 19** Synthesis of thiophene acetylene species.

### 2.3 Synthesis of 2-diisopropylmethylsilylphenylboronic Acid

Creating a catalogue of benzosiloles with varying silyl substituents necessitated the need for a route to acquire various 2-dialkylmethylsilylphenylboronates. Initially the obvious choice was to use the same route used in **Scheme 15**. In order to evaluate the effectiveness of this route on bulkier chlorosilanes triethylchlorosilane (TESCl) was chosen as the obvious model. This reaction failed probably because the bulky protecting group on the boronic acid prevented the addition of the bulky silane. In an attempt to reduce steric hindrance, the original route (**Scheme 11**), was attempted with TESCl starting from 1,2-dibromobenzene. This reaction worked in only a 6% yield for the same reasons described previously.

Work then began on a method using 1,2-dichlorobenzene, turbo Grignard,<sup>72</sup> and a zinc catalyst.<sup>73</sup> This reaction was attempted with a variety of conditions including with TESCl and TESOTf, with different zinc catalysts ( $\text{ZnCl}_2$ ,  $\text{ZnBr}_2$ ,  $\text{ZnCl}_2 \cdot \text{TMEDA}$ ) and with titrated turbo Grignard but no product was recovered. It is believed this reaction did not work because of the possibility of a benzyne intermediate being formed when magnesium or lithium reagents are added to 1,2-dibromobenzene.<sup>74</sup>



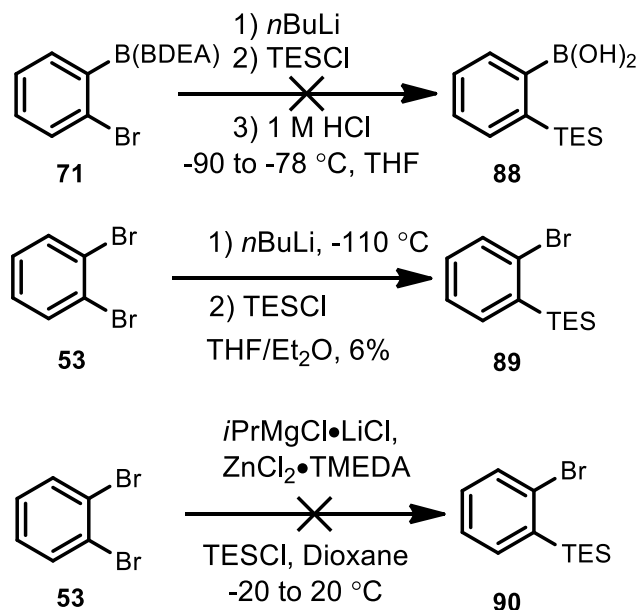

**Scheme 20** Attempted synthesis of 2-triethylphenylboronic acid.

These failures to synthesize 2-triethylsilylphenylboronic acid caused two changes in strategy. The first change was abandoning the synthesis of ethyl substituted benzosiloles because of poor ECL properties in previous studies of siloles.<sup>15</sup> Also, cleaving an ethyl-silicon bond causes longer reaction times and reduced yields over cleaving a methyl-silicon bond in the rhodium catalyzed cycloaddition reaction (**Scheme 8**). The route to access 2-silylphenylboronic acids was also changed to a route detailed by the Chatani group in 2012.<sup>75</sup> This entailed switching to a longer route that would take 5 steps but would avoid cold temperatures and low yielding reactions.

This synthesis that will be discussed later in **Scheme 22** starts via protection of 2-bromophenol with the desired chlorosilane. This necessitates the synthesis of dialkylmethylchlorosilanes, as the vast majority of products that fit this category are not commercially available. The methyl group specifically, was necessary to facilitate rhodium catalyzed C-Si bond cleavage in the formation of the benzosilole. In consulting previous work in the Pagenkopf group regarding the luminescent properties of siloles,<sup>15</sup> it was decided that work should begin with diisopropylmethylchlorosilane. This would hopefully give us the corresponding diisopropyl substituted benzosiloles, which in theory should yield better luminescent properties because it would increase barriers to non-emissive decay. To synthesize **94** an isopropyl Grignard

was first synthesized from magnesium shavings and 2-chloropropane, after which the Grignard was removed from excess magnesium. This solution was heated at 90 °C where trichloromethylsilane was then added slowly and then left overnight at 90 °C. This flask was then treated with concentrated HCl in two portions at 0 °C.<sup>76</sup> Isolation of the organic layer proved to be impossible though as the formation of magnesium salts prevented separation. These magnesium salts had to either be filtered off or a centrifuged. Separation of the organic layer and rotary evaporation gave the crude product followed by distillation to give pure **94**, but using 12 M HCl formed other byproducts which distilled with the product.

To improve the yield, the synthetic route was modified by getting rid of the HCl work-up and adding a cuprous cyanide catalyst.<sup>77</sup> These changes resulted in recovering mostly pure product after distillation in 50% yield. It was later found that upon leaving the **94** in the fridge for a month the chlorosilane separated into a hydrophobic and hydrophilic layer. After removing the hydrophobic layer, an NMR revealed this to be pure **94** and thus would be used in future reactions.

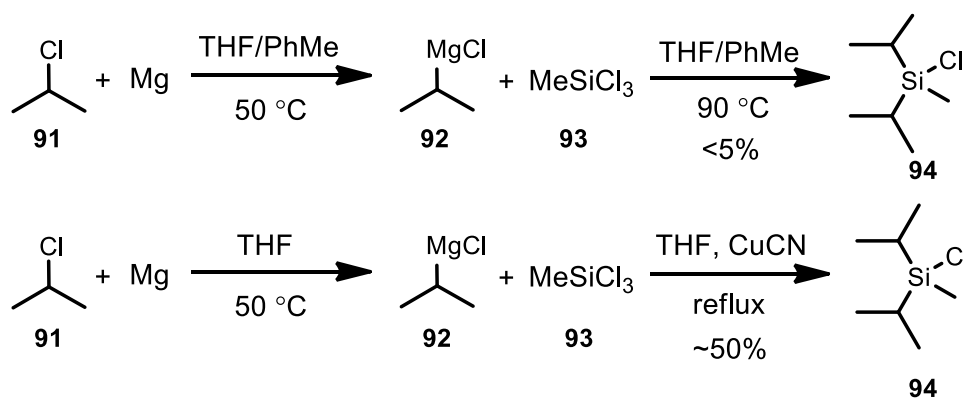

**Scheme 21** Synthesis of diisopropylmethylchlorosilanes.

The synthesis of 2-diisopropylmethylsilylphenylboronic acid was completed in 5 steps from 2-bromophenol (**Scheme 22**). The protection of the 2-bromophenol with the chlorosilane was initially performed with sodium hydride (NaH) as the base in THF to yield **96**.<sup>75</sup> The reaction did not proceed with good yields so 60% NaH in mineral oil was switched to 95% pure NaH. Unfortunately, 95% pure NaH also gave the same 1:1 mixture of products and starting material. The reaction mixture could not be purified by column chromatography as this would remove the protecting group even when the column was treated with triethylamine (Et<sub>3</sub>N). A switch was made

to a different procedure where imidazole was used as the base instead of NaH because it is easier to use and it previously gave good yields protecting 2-bromophenol with bulky triisopropylchlorosilane.<sup>78</sup> The protection with the chlorosilane worked as intended, and all the starting material was consumed after 3 hours at room temperature. It was discovered later that by adding 20 mol % dimethylaminopyridine (DMAP) to the reaction that reaction times could be reduced and yields improved further.<sup>79</sup>

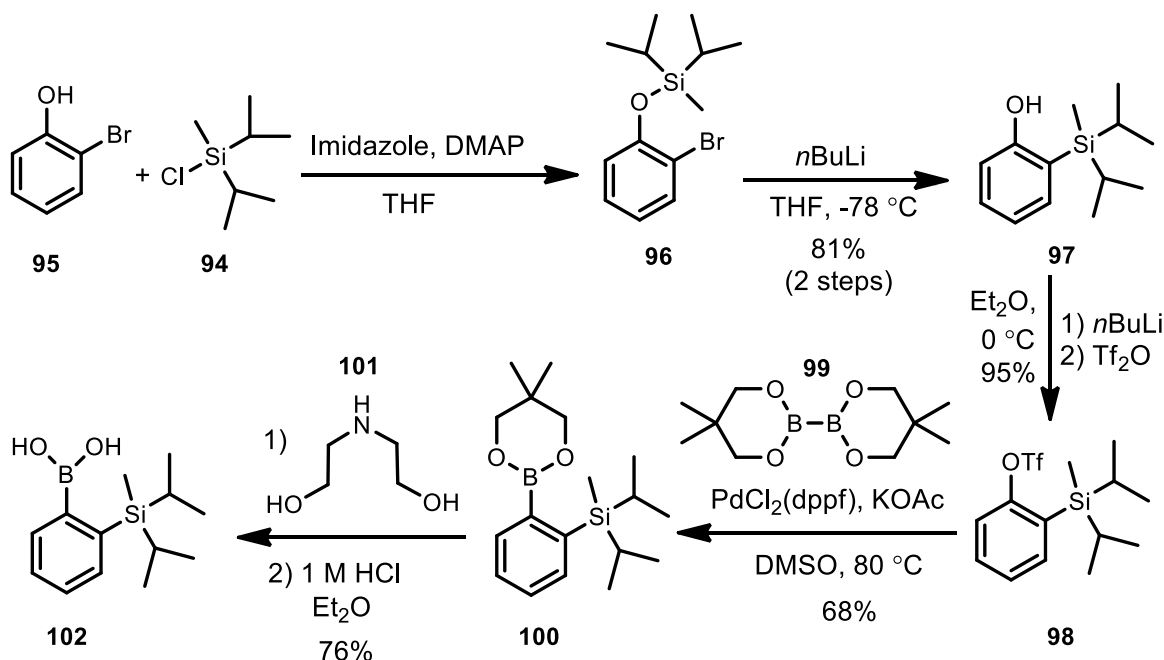

**Scheme 22** Synthesis of 2-diisopropylmethylphenylboronic acid.

This material, **96**, was taken crude to the next reaction the retro-Brook rearrangement. Adding excess *n*BuLi to **96** in THF at  $-78\text{ }^\circ\text{C}$  and stirring for 2 hours gives **97** after column chromatography.<sup>79</sup> The driving force of this rearrangement is the enhanced stability of the lithium phenoxide intermediate over the lithium aryl intermediate.<sup>80</sup> It was discovered that pure chlorosilane **94** was needed because any impurities will result in crude yields of **96** above 100%. Not knowing the exact mass of the product makes it difficult to use the correct amount of *n*BuLi, which results in lower yields and more challenging purification of subsequent steps.

In the next step the **97**, is treated with triflic anhydride ( $\text{Tf}_2\text{O}$ ),<sup>81</sup> and initially this reaction gave low yields with incomplete conversion to the trifluoromethanesulfonate. The pyridine base and the triflic anhydride were then distilled prior to use but complete conversion was not seen. It

was surmised that the 2-diisopropylmethylsilane could be sterically hindering the reaction progress. The base was changed from pyridine to *n*BuLi to facilitate facile deprotonation.<sup>81</sup> The switch to *n*BuLi led to almost complete conversion of starting material and **98** was achieved in a 95% yield.

The synthesis of the corresponding boronate was performed using a palladium catalyzed reaction with the (diphenylphosphino)ferrocene (dppf) ligand. The presence of the palladium catalyst was added to a solution of: base, 2-silylaryl triflate, a boronate source and the starting material **98**. Initial attempts utilized Et<sub>3</sub>N as the base in 1,4-dioxane with pinacolborane.<sup>82</sup> This reaction did not proceed at all and most of the starting material was recovered. It was speculated that the pinacolborane was too bulky to react with sterically hindered **98** so the borane source was changed to bis(neopentylglycolato)diboron **99** ((Bneop)<sub>2</sub>). This change resulted in trace amounts of product being seen in the crude NMR but only starting material was recovered. The reaction conditions were changed to use potassium acetate (KOAc), and dimethyl sulfoxide (DMSO) instead of Et<sub>3</sub>N, and 1,4-dioxane based on work done by John Huffman's group.<sup>83</sup> When these changes were made product was formed after heating 12 hours at 100 °C in 29% yield after column chromatography. Small amounts of starting material were also isolated as well the phenol **97**. The phenol was probably the result of high temperatures used in the presence of a base and a metal catalyst, which is known to deprotect triflates.<sup>84</sup> Lowering the reaction temperature to 80 °C stopped this side reaction. Optimizing the reaction by increasing the concentration of the reaction increased the yield to 68%.

The final step of this reaction was the deprotection of the boronate ester to the boronic acid, initially attempted with a few drops of 12 M HCl in acetone/H<sub>2</sub>O stirring overnight.<sup>85</sup> This reaction though did not proceed even with excess equivalents of HCl and longer reaction time. Alternative deprotection methods were considered including oxidative cleavage with sodium periodate,<sup>86</sup> and *trans*-borylation.<sup>87</sup> These ideas were abandoned because of harsh chemicals and conditions needed for these reactions. The next deprotection strategy was a 2 step process using diethanolamine (DEA) followed by dilute acid hydrolysis.<sup>88</sup> Treatment of the neopentyl boronate with DEA creates the DEA boronate ester, and upon treating of this species with 1 M HCl gave the boronic acid, **102**, after work up in a 76% crude yield.

## 2.4 Synthesis of Nitrile Containing 2-silylphenylboronic acid

The desire for benzosiloles that could act as chromophores in biological labeling required the synthesis of a functional group that could be coupled to biomolecules (**Scheme 10**). The plan was to use a versatile functional group that could survive the synthesis of the benzosilole and then be transformed into something more facile. The work of S. Lulinski and J. Serwatowski using of lithium diisopropylamine (LDA) to deprotonate *ortho* to arylbromide followed by trapping with TMSCl was suggested by Dr. Kerr.

In this paper they report a disilylation of 1-bromo-4-cyanobenzene using LDA.<sup>89</sup> This procedure would allow the introduction of a nitrile to a system containing 2-silylbromobenzene without using the previous challenging  $-110\text{ }^{\circ}\text{C}$  reaction. Initially the idea was to only install a TMS group *ortho* to the bromine, as required for the rhodium catalyzed cycloaddition reaction. This proved impossible as adding only one equivalent each of LDA and TMSCl would result in a 1:1:1 ratio of starting material, monosilylated and disilylated products. The LDA was made *in situ* from *n*BuLi and diisopropylamine at  $-78\text{ }^{\circ}\text{C}$ , then adding a solution of **103** and TMSCl to the solution of LDA at  $-78\text{ }^{\circ}\text{C}$ . The disilylated product was recovered in a 72% crude yield with small amounts of an unidentified byproduct. This was then used in the next reaction without further purification. The next reaction was done according to (**Scheme 11**) by cooling to  $-78\text{ }^{\circ}\text{C}$ , adding *n*BuLi, stirring for 30 minutes and adding triisopropyl borate. Then 1 M HCl was added after 18 hours to hydrolyze the solution. Finally, column chromatography was performed on the crude mixture and then **105** was washed with hot hexane (**Scheme 23**).

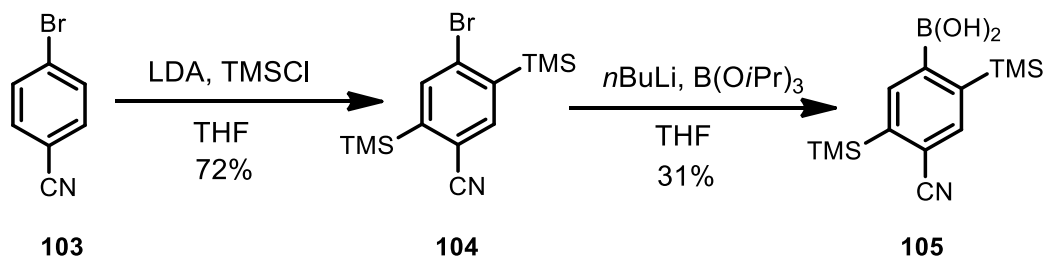

**Scheme 23** Synthesis of 2,5-bis(trimethylsilyl)-4-nitrilephenylboronic acid.

## 2.5 Synthesis of Benzosiloles

The Chatani group had previously synthesized a variety of benzosiloles, including one with thiophenes, **106**, in previous work.<sup>75</sup> Using this procedure a new series of benzosiloles were created from the newly synthesized 2-silylphenyl boronates and thiophene-acetylenes. The reaction to synthesize **106** was replicated and product was recovered in 24% yield. The low yield reported is not important because all that is needed is enough compound to test ECL efficiency.

Synthesis of benzosilole **107** was performed next and heated to 80 °C for 3 days. After 3 days only small amounts of starting materials were left unreacted. The solution could then be filtered and column chromatography was performed to recover the product as a bright yellow solid. The benzosilole will decompose in less than two weeks at room temperature and decomposes slowly in the fridge if left for two months.

Synthesis of benzosilole **108** was attempted three times but only worked once in a low yield (3%) because of the instability of **87**. As stated previously **87** decomposes in air and under light almost immediately. This makes it extremely difficult to determine both the purity of the material and the correct stoichiometry to use in the reaction. Compounding this problem is the fact that since the halogenation of terthiophene (**Scheme 17**) the products have not been purified. Running three reactions without purification can cause yields to lower exponentially in subsequent reactions. Specifically, the success of the one-pot Sonogashira reaction can only be determined after the benzosilole reaction is complete, forming **108**. For example, the first time the rhodium catalyzed cycloaddition reaction was attempted it failed because **87** was not synthesized in the Sonogashira reaction. The second attempt yielded a bright orange solid that was shown to contain product by mass spectrometry. This product also contained an inseparable byproduct that was believed to be caused by a terthiophene-acetylene oligomer reacting with **55**. Attempts to purify **108** by column chromatography or gel permeation chromatography (GPC) both failed. The desired benzosilole, **106**, was finally recovered on the third try after 767 mg of **87** was used and heated for 1.5 days at 90 °C to give only 15 mg of product. The yield for this reaction is extremely low and does not represent the maximum possible yield, only the yield of this particular reaction upon

isolation. If the bis(terthiophene)acetylene (**87**) could be obtained with minimal decomposition, then **108** would likely be obtained in greater yields.

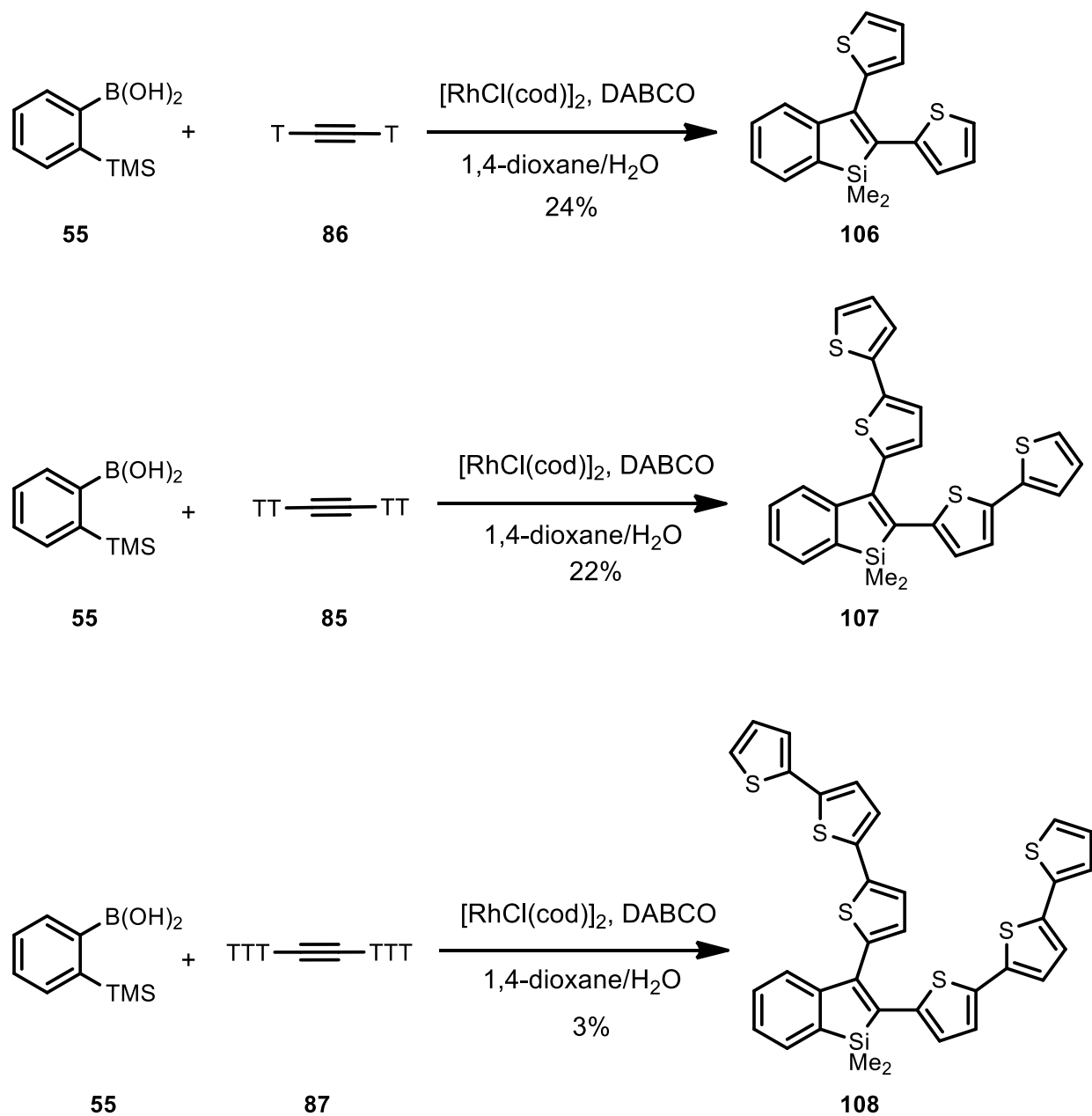

**Scheme 24** Synthesis of oligothiophene substituted benzosiloles.

The benzosiloles containing nitriles were synthesized by the same procedure as in **Scheme 24**. Product **109** was achieved by heating for one day followed by column chromatography. In the course of doing this reaction multiple times it was discovered that heating times between 1 and 3 days did not cause significant changes in yield. The reaction progress cannot be followed because the starting material, **86**, is masked by multiple byproducts making TLC analysis challenging.

The next benzosilole **110** was synthesized by heating for 2 days before being stopped after no change was seen by TLC analysis from the first day to the second day. The last product in the series **111** was synthesized successfully according the same procedure,<sup>75</sup> giving the product as a bright orange solid in low yields. The success of this reaction, like **108** depends greatly on the purity of **87**. If the acetylene used has decomposed, it will reduce yields as well as complicate the column chromatography needed to purify the reaction.



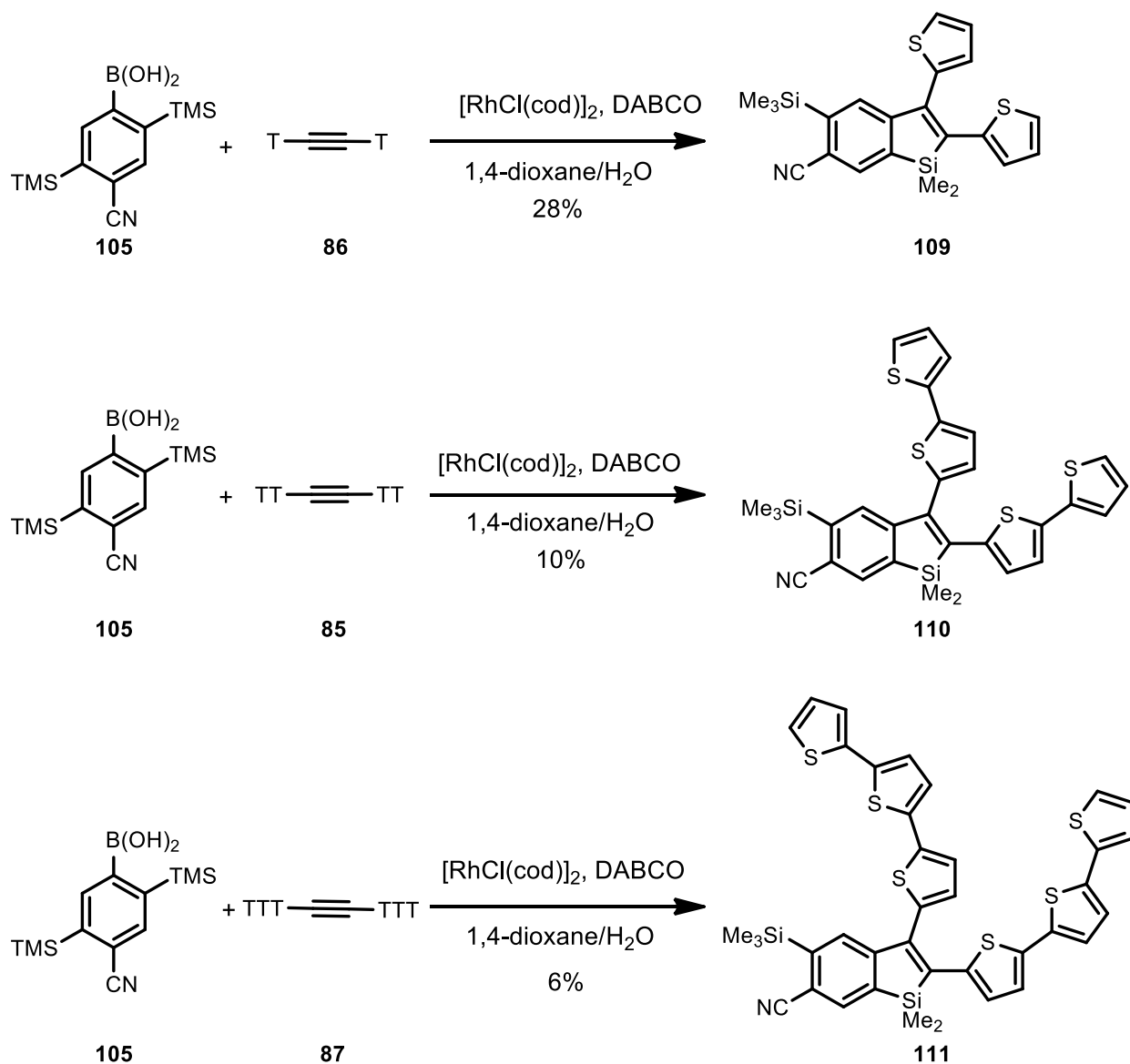

**Scheme 25** Synthesis of nitrile substituted benzosiloles.

The synthesis of benzosiloles with diisopropylsilyl substituents was attempted from **112**. This rhodium catalyzed reaction was first attempted with **86** because of its ease of synthesis and good yields reported previously. There were two products that were expected from this reaction. The first product (**114**) is a result of the rhodium catalyst cleaving the Si-C bond on the methyl group in **112**. The second product (**113**) can result from cleaving the Si-C bond from an isopropyl group, which would reduce the sterics of the system allowing the benzosilole to form. It is expected

based on previous work that the second product would be much more likely to form in large excess.<sup>75</sup> The benzosilole reaction in **Table 1** was done a number of times but each time no product was recovered even with reaction times longer than 4 days. The presence of either the neopentylglycol boronate ester or the boronic acid did not affect the progress of the reaction. Using higher temperatures in the microwave at 160 °C for 10 minutes did not provide either product (**113** or **114**). The reason the rhodium catalyzed cycloaddition did not work is probably due the bulky silyl group that prevents the oxidative addition of the rhodium catalyst that results in cleavage of the silicon-carbon bond. Unfortunately, attempts to synthesize **114** were stopped because this product cannot be achieved without changing the synthetic route and time restraints made this impossible.

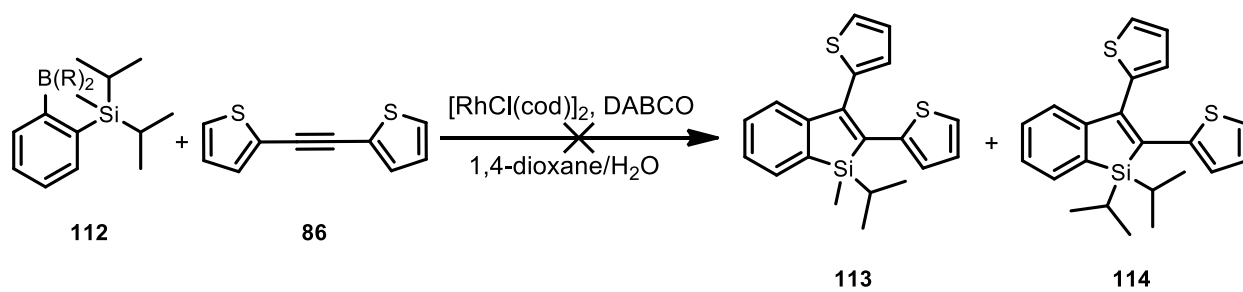

Run	B(R)	Temp (°C)	Time	Product
1	B(neop)	90	4 days	-
2	B(neop)	160*	10 min	-
3	B(OH) <sub>2</sub>	90	2 days	-

\*Microwave reaction

**Table 1** Attempted synthesis of isopropyl substituted benzosiloles.

To synthesize benzosiloles with pendant amines will have to be reduced either before or after the rhodium-catalyzed cycloaddition. Reducing the nitrile early would be easier but would also require the manipulation of protecting groups to be effective. The other option is doing a late stage reduction, which would be challenging because of the added complexity of the molecule but would also require less steps. It was decided to do the latter because the reduction could be done simply from **109** synthesized previously. Next it was important to select a method of reduction that would work in good yields in the presence of the functional groups present. The presence of a silyl

group meant that reductions using reagents such as *tert*-butylammonium fluoride (TBAF) could not be used because of the likelihood of cleaving carbon-silicon bonds.<sup>90</sup> Other methods that were considered included the use of  $\text{SmI}_2$ <sup>91</sup> or use of a ruthenium catalyst for selective reduction.<sup>92</sup>

Initially a reduction using nickel boride was attempted, made *in situ* from  $\text{NaBH}_4$  and anhydrous  $\text{NiCl}_2$ .<sup>93</sup> This reaction only led to the recovery of large amounts of hydrocarbons. It is speculated that the nickel boride is probably cleaving the carbon-sulfur bonds in the thiophene.<sup>94</sup> A simple reduction using lithium aluminum hydride ( $\text{LiAlH}_4$ ) was then performed.<sup>95</sup> The reduction was attempted a number of times with different reaction times but the starting material was never completely consumed. The reaction also gave a lot of byproducts including over reduced products. Product was seen by crude NMR in low yields but pure product could not be isolated.

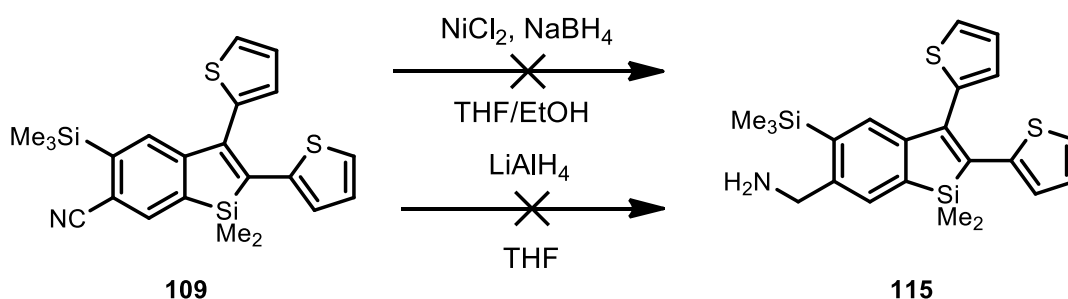

**Scheme 26** Attempted reduction of nitrile with nickel boride and LAH.

The need for a milder nitrile reduction led to using aminoboranes as reducing agents. The use of diisopropylaminoborane with a catalytic amount of  $\text{LiBH}_4$  was shown previously to reduce aromatic nitriles. Although  $\text{LiBH}_4$  and diisopropylaminoborane by themselves normally are inert towards nitriles it is suspected that the lithium ion coordinating to the nitrogen activates it so amino borane can reduce the nitrile.<sup>96</sup> The diisopropylaminoborane reagent is easily synthesized from lithium diisopropylaminoborane (LAB) *in-situ* with  $\text{TMSCl}$ . The LAB reagent itself is synthesized by a two-step procedure and can be stored in the fridge until use.<sup>97</sup> The *in-situ* generated diisopropylaminoborane is then added slowly to a solution of **109** and  $\text{LiBH}_4$  in THF. After stirring overnight and working up it was revealed to be mostly starting material with only traces of product by crude NMR. The reaction did not go to completion because of the bulky TMS group sterically hindered the aminoborane from reducing the nitrile.<sup>96</sup>

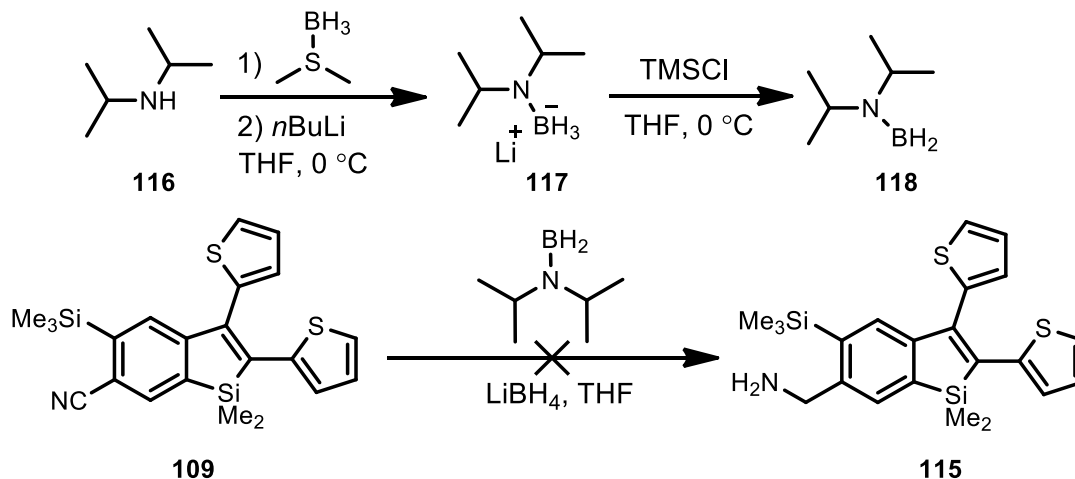

**Scheme 27** Failed reduction with diisopropylaminoborane.

The final strategy to reduce nitriles under mild conditions used sodium borohydride with trifluoroacetic acid (TFA). The addition of these two reagents creates  $\text{NaBH}_3\text{OCOCF}_3$  *in situ* which can reduce the nitrile.<sup>98</sup> There are many examples of this reaction working with sensitive functional groups and *ortho*-substituted aromatic nitriles.<sup>99</sup> Initial trials of this reaction at small scale showed the presence of product along with evidence of over reduction. Done on a larger scale pure product could be isolated by column chromatography in 27% yield. The isolation of this product allows us to compare the PL and ECL properties of reduction product **109** to **115**, which will determine if these compounds have any real world applications.

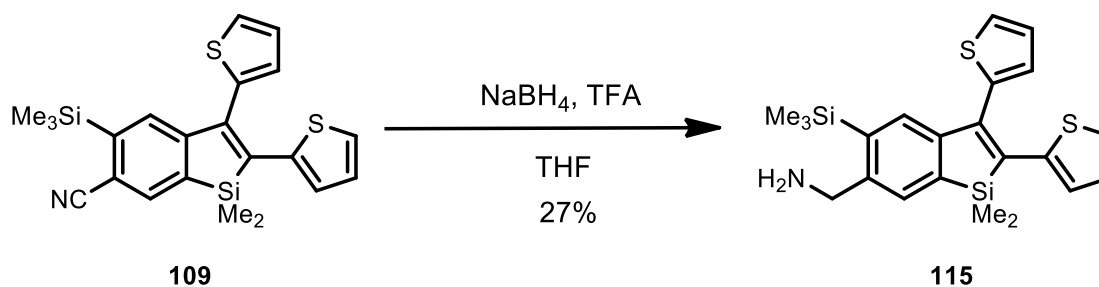

**Scheme 28** Effective reduction the nitrile with trifluoroacetic acid and sodium borohydride.

## 2.6 Results of ECL Experiments

ECL experiments have been done for more than 50 years since Hercules and Bard performed the first detailed ECL experiments in the mid-1960s;<sup>100,101</sup> since that time ECL has become a powerful analytical technique.<sup>102</sup> Electrogenerated chemiluminescence (or electrochemiluminescence) is the process whereby high energy species are created at electrodes and then undergo electron-transfer reactions to create an excited species. The excited state then emits light upon relaxation to the ground state.<sup>103</sup> This process can occur by either annihilation ECL or coreactant ECL. Annihilation ECL is observed by scanning the electrode within a short time interval to generate high energy radical anions ( $R^-$ ) and radical cations ( $R^+$ ) from a luminophore ( $R$ ), (Equation 1 and 2, **Figure 14**). These species then react with each other to give the excited species ( $R^*$ ) (Equation 3, **Figure 14**), and a ground state species ( $R$ ). The excited species then relaxes to the ground state to emit light (Equation 4, **Figure 14**).



**Figure 14** General mechanism for annihilation ECL, where radical cation and radical anion to form  $R^*$ . This excited species relaxes back down to the ground state and releases light.

Recently coreactant ECL has become the preferred method, as all analytical ECL instruments available for commercial use are based on coreactant technology. In coreactant ECL a reagent (coreactant) is added to a solution of the ECL luminophore (the emitter). This is done when one of the radical species ( $R^-$  or  $R^+$ ) of the luminophore is unstable, or as a way to increase ECL intensity.<sup>102</sup> Common coreactants include tri-*n*-propylamine, benzoylperoxide, and oxalate. Tri-*n*-propylamine for example, loses  $H^+$  when oxidized to form radical intermediate TPrA $\cdot$

(Equation 1, **Figure 15**). This species is a powerful reducing agent and can react with the oxidized luminophore ( $D^+$ ) to generate an excited luminophore species, which emits light (Equation 3 and 4, **Figure 15**).<sup>104</sup> The benefit of a coreactant is the oxidizing and reducing intermediates are generated in a single potential step. Annihilation ECL on the other hand requires a double potential step to generate both high energy intermediates (oxidation followed by reduction).

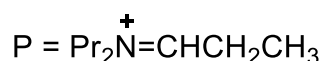
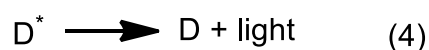
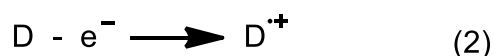
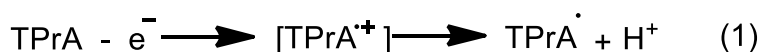

**Figure 15** General mechanism of coreactant ECL with TPrA as coreactant. The chromophore (D) gets oxidized to radical cation while TPrA is oxidized followed by loss of  $\text{H}^+$ . The two resulting radical species then react to form the excited species  $\text{D}^*$  which emits light upon relaxation.

ECL has now found uses in a number of fields including: biomedical diagnostics (eg. immune assays), food and water testing, and biowarfare agent testing. This has led to a dramatic increase in research being on ECL and ECL luminophores. The development of new luminophores is focused on those which possess high quantum efficiency, sensitivity, selectivity, ease of preparation, and low cost. In addition, the new material should produce stable radical ions that allow for efficient diffusion between layers of OLEDs, for example. The luminophores are separated into three categories: nano particle systems, inorganic systems, and organic systems. The most popular luminophore in inorganic systems is  $\text{Ru}(\text{bpy})_3^{2+}$  (tris(bipyridine)ruthenium(II)), responsible for taking ECL from a simple curiosity to a technique with many real world applications.<sup>104</sup> Siloles are used in organic systems where they are relatively new to the world of ECL, the first study of the ECL properties of siloles being done in 2006 by Pagenkopf and Bard.<sup>105</sup>

The benzosiloles that were synthesized above were given to the Ding group in order to determine their ECL and PL properties. Of all the compounds studied **108** and **111** displayed the best luminescent properties. This due to the extended  $\pi$ -conjugation present in the system which stabilizes radical ions and lowers the HOMO-LUMO gap.<sup>106</sup> Only the results of the ECL experiments performed on **108** and **111** will be discussed in this section.

The ECL experiments were first performed by annihilation and the data is presented as a CV overlaid with the ECL photocurrent/voltage curve recorded simultaneously (**Figure 16**). A cyclic voltammogram shows the current flowing through the system as a function of potential. The electrode potential sweeps linearly with time in a cyclic pattern. The ECL-voltage curve represents the light emission from the compound, reported as photocurrent.

The CV shows that **108** undergoes two oxidations, as shown by plateaus between 0 and 0.5 V. These oxidations are non-reversible because we do not see the same step-wise transition upon lowering the potential back to 0 V. Scanning to negative potentials reveals two reduction steps that happen below 2.0 V. The location of the ECL-voltage curve at the time of reduction reveals that the radical anions formed are not as stable as the radical cations. Light is only emitted once the radical anion has been generated, which means that the radical cation is stable in solution until the potential sweeps from positive to negative. The ECL generated in this experiment is not very efficient, registering around 17 nA, this is poor when contrasted against previous work in the Pagenkopf group, where previous siloles (**12**) had photocurrents of over 1 mA.<sup>15</sup> This is possibly due to all the aryl rings not being in the same plane, which would cause ineffective conjugation. The radical cations generated in the experiment can therefore not be stabilized across the entire  $\pi$  system.

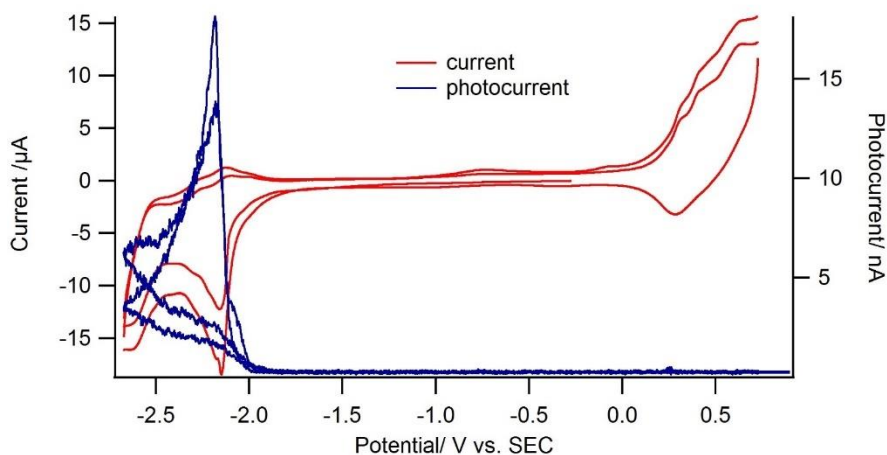

**Figure 16** Cyclic Voltammogram (red) and ECL-voltage curve (blue) of **108** in an annihilation system. The applied voltage sweeps from 1 V to -3 V and back to 1 V in a cyclic pattern over a period of time. The CV shows 2 non-reversible oxidations and reductions, while the ECL-voltage curve shows photocurrent of over 15 nA.

To improve the results of the ECL experiments TPrA was added as a coreactant (**Figure 17**). The coreactant acts to enhance ECL because both radical species are generated at the same electrode simultaneously and react together within the vicinity of the electrode. The addition of TPrA causes the intensity of ECL to increase fivefold to over 80 nA. Comparisons can be made to similar systems using  $\text{Ru}(\text{bpy})_3^{2+}/\text{TPrA}$  designed for DNA hybridization detection, where they reported ECL intensities of around 300 nm.<sup>107</sup> If the benzosiloles described above are to have any commercial application the ECL intensities would have to be increased to this standard.



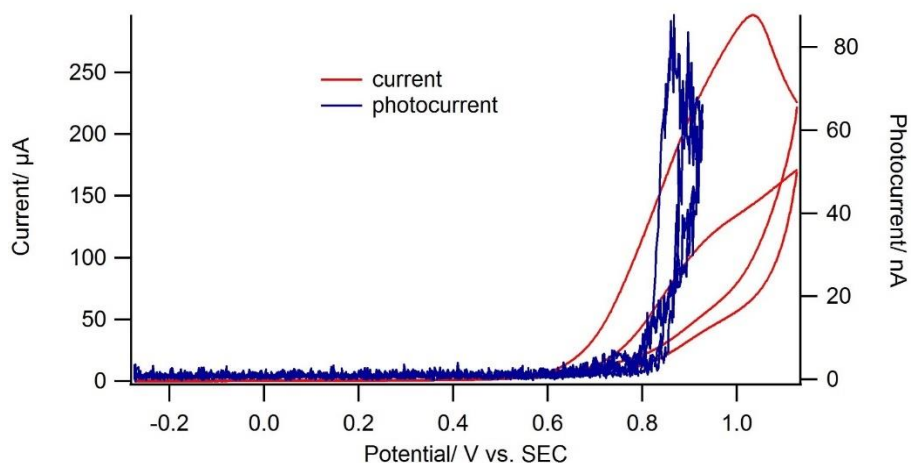

**Figure 17** Cyclic voltammogram (red) and ECL-voltage curve (blue) of **108** with TPrA as coreactant. The voltage is applied linearly versus time from 0 V to 1.2 V. The ECL intensity is represented as the photocurrent generated, which is 80 nA for **111**.

The CV for **111** displays two oxidations that are non-reversible (**Figure 18**), which is consistent with **108**. There are also two successive reductions that occur, but their peak potentials are convoluted. Similar to **108** the radical anions are unstable and react immediately with radical cations. The ECL intensity in this system is only 6 nA of photocurrent, which is less than half photocurrent generated by annihilation in **108**. Interestingly 1 nA photocurrent is also generated upon scanning to positive potentials. This is likely due to creating a radical anion on the nitrile moiety, which is stable enough to react with a radical cation of **111**.

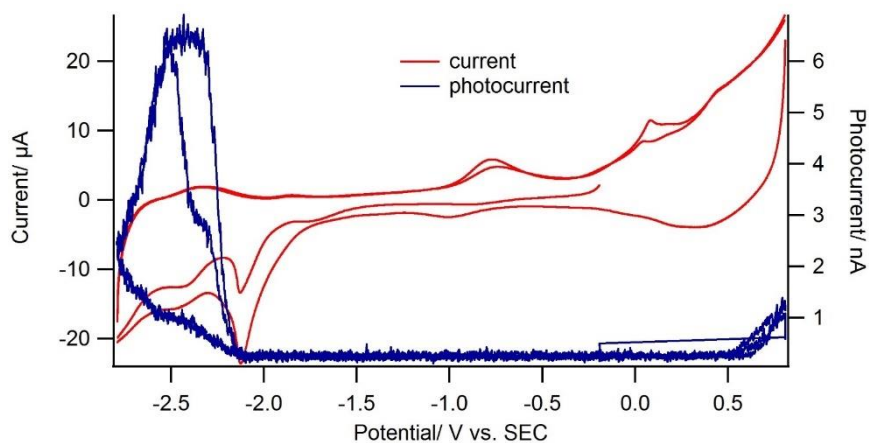

**Figure 18** Cyclic Voltammogram (red) and ECL-voltage curve (blue) of **111** in an annihilation system. The applied voltage sweeps from 1 V to -3 V and back to 1 V in a cyclic pattern over a

period of time. The CV shows 2 non-reversible oxidations and reductions, while the ECL-voltage curve shows photocurrent of 7 nA plus an additional 1 nA being generated via a side reaction with the nitrile.

Adding TPrA to this system again resulted in an increase in ECL intensity, approximately ten fold higher than those seen in the annihilation system (**Figure 18**). The cause for this drastic increase in ECL is probably the reduction of the nitrile to generate radical anions that react with the radical cations to produce an excited state. The nitrile can be reduced by the powerful reducing agent TPrA<sup>•-</sup> which usually reacts with the radical cation of the chromophore to produce an excited state, but can also reduce the nitrile in this case. Overall these compounds display moderate to poor ECL properties even when a coreactant is used. ECL intensity could be improved by tuning the silyl substituents of the thiophene-benzosiloles, similar to the work done in **Figure 9**.

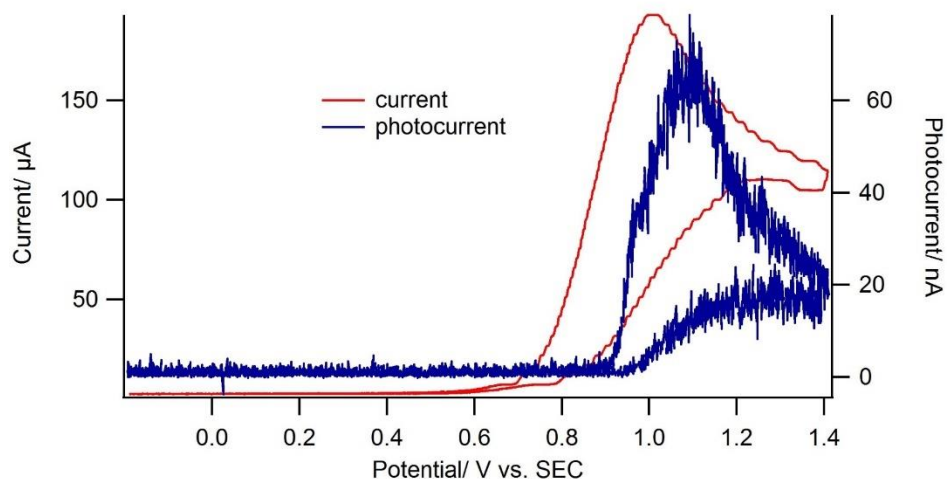

**Figure 19** Cyclic voltammogram (red) and ECL-voltage curve (blue) of **111** with TPrA as coreactant. The voltage is applied linearly versus time from 0 V to 1.4 V. The ECL intensity is represented as the photocurrent generated, which is 70 nA for **111**.

The ECL spectra for this compound (**Figure 20**) shows a peak wavelength of around 500 nm, which is comparable to ECL spectra for siloles reported previously.<sup>15</sup>

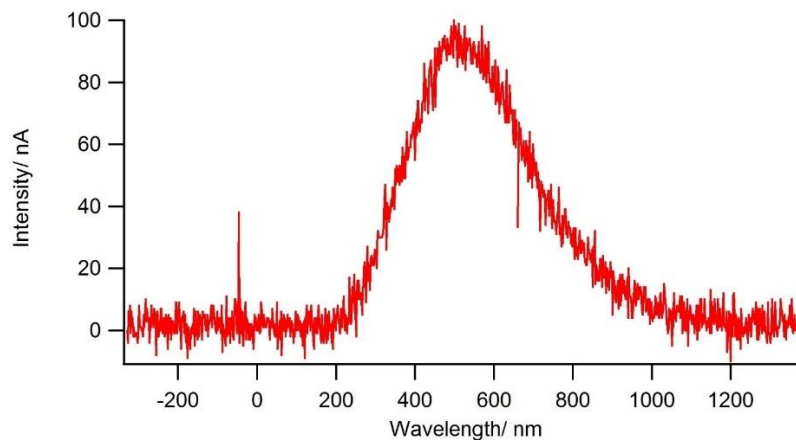

**Figure 20** ECL spectra of **108** showing  $\lambda_{\text{max}}$  of around 500 nm.

### 3.0 Conclusions and Future Work

Presented herein is the synthesis of benzosilole-thiophene chromophores. In total 6 novel benzosiloles have been synthesized using a rhodium catalyzed cycloaddition from 2-silylphenyl boronates and bis(thiophenyl)acetylenes. This includes benzosiloles supporting both electron-withdrawing groups and electron donating groups. These benzosiloles were then submitted to Dr. Zhifeng Ding's group at the University of Western Ontario in order to examine their ECL and PL properties. It was revealed that benzosiloles possessing the most thiophenes, and therefore the most conjugation, displayed the highest degree of luminescence. Additionally, benzosiloles possessing electron-withdrawing groups displayed superior ECL properties over their analogues.

An attempt was also made to synthesize benzosiloles with varying silyl substituents. Benzosiloles with isopropyl groups at the 1,1-positions were targeted specifically to increase the steric bulk of the molecule and reduce non-emissive energy decay. Introducing alkyl groups of different size to the 1,1-positions could also change the angle of the thiophenes resulting in a higher degree of coplanarity between the benzosilole and the thiophene moiety. The resulting increase in conjugation could lead to more efficient ECL. The synthetic route was stopped here because the system proved too sterically hindered to form the product and work in this area was stopped because of time constraints. The rhodium catalyzed cycloaddition works when small trimethylsilyl

substituents are used, but limitations are evident when we try to synthesize benzosiloles with diisopropylsilyl substituents. The rhodium catalyst cannot undergo oxidative addition in sterically hindered systems to cleave the carbon-silicon bond, and therefore the benzosiloles are not synthesized. Synthesis of 1,1-diisopropyl substituted benzosiloles must therefore be done via a different route in the future. Alternatively, 1-isopropyl-1-methyl substituted benzosiloles could be synthesized from dimethylisopropylsilylphenylboronic acid, which has been reported previously by the Chatani group.<sup>75</sup> By synthesizing 1-isopropyl-1-methylbenzosiloles we could determine if increasing the sterics of the groups at the silicon atom plays a significant role in improving the ECL properties compared to less bulky 1,1-dimethylbenzosiloles.

Future work would see the completion of the 1,1-dimethyl substituted benzosiloles to include a full series of benzosiloles with benzyl amine moieties. These benzosiloles containing primary amines could then be coupled to biomolecules to gauge their potential applications as ECL chromophores. If it turns out these electron-donating benzosiloles displays inferior ECL properties work would be done in the future to synthesize benzosiloles with carboxylic acid substituents to facilitate biomolecule coupling.

## 4.0 Experimental

### 4.1 General Experimental Details

All reactions were run in an atmosphere of argon and all flasks were either stored overnight in a 110 °C oven or were flame dried under vacuum prior to use. Toluene, dichloromethane, tetrahydrofuran, diethylether, 1,4-dioxane were all purified by passing through activated alumina columns. All other solvents and reagents were purified using standard procedures.<sup>108</sup> All chemicals used were of reagent grade and were obtained from commercial sources unless otherwise stated. The progress of reactions was monitored by TLC on F254 silica gel plates. The plates were visualized using UV light (254 nm) or stained with ceric ammonium molybdate (CAM)<sup>109</sup> or with KMnO<sub>4</sub>. Standard column chromatography was performed on Silica Flash P60 60 Å silica gel (from Silicycle) using flash column chromatography techniques.<sup>110</sup>

$^{13}\text{C}$  and  $^1\text{H}$  spectra were recorded on INOVA 600 or 400 MHz spectrometers. The chemical shifts are reported in parts per million (ppm) and were all run in deuteriochloroform and referenced to the residual chloroform peak at  $\delta$  7.26 ppm for  $^1\text{H}$  spectra and the center peak of the triplet at  $\delta$  77.0 ppm for  $^{13}\text{C}$  spectra. When peak multiplicities are given the abbreviations are as follows: s, singlet; d, doublet; t, triplet; doublet of doublets; dt, doublet of triplets; m, multiplet. Infrared Spectra (IR) were obtained using a Bruker Tensor 27 spectrometer. Absorptions are reported in reciprocal centimeters with the relative intensities as follows: s (strong), m (medium), w (weak). Electron ionization mass spectra were obtained on a Thermo Scientific DFS spectrometer at an ionizing voltage of 70 eV.

## 4.2 Experimental Details

The following compounds were synthesized according to literature procedures and the NMR data is consistent with that of the literature: **54**,<sup>29</sup> **62**,<sup>111</sup> **63**,<sup>112</sup> **67**,<sup>57</sup> **71**,<sup>58</sup> **74**,<sup>113</sup> **75**,<sup>114</sup> **76**,<sup>115</sup> **83**,<sup>70</sup> **84**,<sup>71</sup> **86**,<sup>72</sup> **89**(synthesis,<sup>29</sup> data<sup>116</sup>).

(2-(trimethylsilyl)phenyl)boronic acid (**55**)

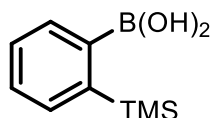

To a 25 mL round bottom flask equipped with a stir bar 10 mL of THF was added. The solution was cooled to  $-78\text{ }^\circ\text{C}$  and *n*BuLi (1.8 mL, 1.7 M, 3.0 mmol) was added and then the solution was further cooled to  $-90\text{ }^\circ\text{C}$ . Another dry 25 mL flask with a stir bar was charged with **71** (834 mg, 2.6 mmol, 1 equiv) and THF (3 mL). The solution of **71** was added to the  $-90\text{ }^\circ\text{C}$  *n*BuLi solution slowly over 5 min. The solution was allowed to warm to  $-78\text{ }^\circ\text{C}$  and was stirred for 20 min, followed by cooling to  $-90\text{ }^\circ\text{C}$ . TMSCl was added slowly to the solution followed by stirring for 30 min. A solution of 1 M HCL (10 mL) was added and the reaction was allowed to warm to room temperature. The organic layers were separated and were evaporated under reduced pressure. The crude residue was loaded onto a silica gel plug and flushed with hexanes. Flushing the plug with ethylacetate and evaporating the resulting solution under reduced pressure gives the title

compound as a white solid (183 mg, 37%).<sup>58</sup>  $R_f$  0.31 (4:1 hexanes/ethyl acetate). The  $^1\text{H}$  NMR data for this compound is consistent with that of the literature.<sup>29</sup>

trimethyl(2-(4,4,5,5-tetramethyl-1,3,2-dioxaborolan-2-yl)phenyl)silane (**68**)

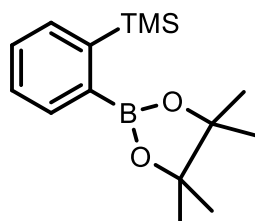

To a dry 100 mL flask equipped with a stir bar, **67** (407 mg, 1.2 mmol, 1 equiv) in 30 mL of THF was added. The flask was cooled down to  $-78\text{ }^\circ\text{C}$  and  $i\text{PrMgCl}\cdot\text{LiCl}$  (3.5 mL, 0.4M, 1.1 equiv) was added dropwise (The  $i\text{PrMgCl}\cdot\text{LiCl}$  reagent was prepared from a literature procedure).<sup>117</sup> The solution was stirred for 1 h at  $-78\text{ }^\circ\text{C}$  and then  $\text{CuCN}\cdot\text{LiCl}$  (1.7 mL, 1.2 mmol, 1 equiv) was added (The  $\text{CuCN}\cdot\text{LiCl}$  was made from a literature procedure).<sup>118</sup> The solution was stirred at  $-78\text{ }^\circ\text{C}$  for 20 min and then  $\text{TMSCl}$  (1.7 mL, 13 mmol, 11 equiv) was added dropwise. The reaction mixture was allowed to warm to room temperature and an aqueous solution of  $\text{NH}_4\text{Cl}$  was added. The mixture was extracted with  $\text{Et}_2\text{O}$  (3 x 10 mL) and  $\text{CHCl}_3$  (2 x 10 mL) then the organic extracts were dried over  $\text{MgSO}_4$ . The solution was filtered through Celite and evaporated under reduced pressure. The resulting crude mixture was purified by column chromatography (5%  $\text{EtOAc}$  in hexanes) to afford the product as a white solid (43 mg, 13%).<sup>76</sup>

1,2-di([2,2'-bithiophen]-5-yl)ethyne (**85**)

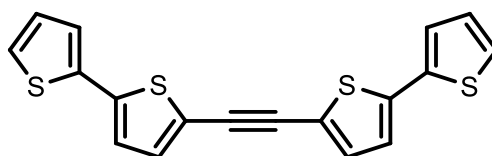

To a dry 50 mL flask equipped with a stir bar,  $\text{PdCl}_2(\text{PPh}_3)_2$  (230 mg, 0.33 mmol, 5 mol %),  $\text{CuI}$  (125 mg, 0.66 mmol, 10 mol %),  $\text{DBU}$  (2.8 mL, 19 mmol, 3 equiv), **75** (1.556 g, 6.3 mmol, 1 equiv), and  $\text{PhMe}$  (25 mL) were added. The solution was degassed with argon for 15 min followed

by addition of (trimethylsilyl)acetylene (0.45 mL, 3.3 mmol, 0.5 equiv) and H<sub>2</sub>O (0.02 mL). The solution was then heated at 80 °C for 18 h and then allowed to cool to room temperature. The solution was then filtered through a silica gel plug with CH<sub>2</sub>Cl<sub>2</sub> and evaporated under reduced pressure. The crude mixture was then purified by column chromatography (5% CH<sub>2</sub>Cl<sub>2</sub> in hexanes) to give the product as a bright yellow solid (430 mg, 37%).<sup>72</sup> The <sup>1</sup>H NMR data for this compound are consistent with those previously reported in the literature.<sup>119</sup>

chlorodiisopropyl(methyl)silane (**94**)

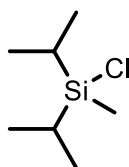

To a dry round bottom flask equipped with a stir bar, magnesium shaving (11.1 g, 457 mmol, 3.3 equiv), 2-chloropropane (30 mL, 329 mmol, 3 equiv), and THF (65 mL) were added. A reflux condenser was then added and the solution heated at reflux for 2 h and the allowed to cool to room temperature. The isopropylmagnesium chloride that was synthesized was then cannulated into another dry flask quipped with a stir bar. Cuprous cyanide (138 mg, 1.6 mmol, 1.4 mol %) was then added to the solution and the flask was equipped with a reflux condenser. Then trichloromethylsilane was added slowly to the solution and the mixture was heated to reflux for 1 h. The flask was then allowed to cool to room temperature and the THF was removed under reduced pressure. A large excess of Et<sub>2</sub>O was added to the flask and the mixture was filtered through Celite, followed by rotary evaporation. The resulting oil was then distilled (72 °C/45 mmHg) and the distillate was placed in a fridge. Left in the fridge for 1 month a hydrophobic and hydrophilic layer formed. The hydrophobic layer was separated and the resulting clear oil was identified as the pure product (9.012 g, 50%). The <sup>1</sup>H NMR data for this compound are consistent with those previously reported in the literature.<sup>78</sup>

2-(diisopropyl(methyl)silyl)phenol (**97**)

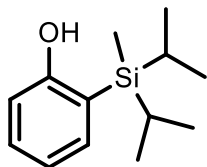

A 50 mL round bottom flask, equipped with a stir bar was charged with **96** (1.9 g, 6.4 mmol, 1 equiv) taken crude from the previous reaction. Then THF was added (25 mL) and the solution was cooled to  $-78\text{ }^{\circ}\text{C}$  by a dry ice/acetone bath. *n*BuLi (5.7 mL, 2.2 M, 2 equiv) was then added slowly over 5 minutes. This solution was then stirred for 2 h at  $-78\text{ }^{\circ}\text{C}$ , and then  $\text{NH}_4\text{Cl}$  (50 mL) was added to stop the reaction. The solution was then allowed to warm to room temperature and diluted with EtOAc (65 mL). The phases were then separated, and the organic layer was washed with NaCl (2 x 30 mL). Then  $\text{MgSO}_4$  was added and the solution was filtered through a Celite pad and concentrated in vacuo. The crude residue was then purified by column chromatography (10% EtOAc/hexanes) to yield the title compound as a colourless oil (972 mg, 81%).  $R_f$  0.66 (4:1 hexanes/ethyl acetate);  $^1\text{H}$  NMR (600 MHz,  $\text{CDCl}_3$ );  $\delta$  0.25 (s, 3 H), 0.96 (d,  $J = 7.0$  Hz, 6 H), 1.03 (d,  $J = 7.6$  Hz, 6 H), 1.31 (sep,  $J = 7.6$  Hz, 2 H), 4.74 (s, 1 H), 6.68 (dd,  $J = 1.2$  Hz, 8.2 Hz, 1 H), 6.93 (ddd,  $J = 1.2, 8.2, 7.0$  Hz, 1 H), 7.24 (ddd,  $J = 1.8, 8.2, 7.0$  Hz, 1 H), 7.34 (dd,  $J = 1.8, 7.0$  Hz, 1 H).  $^{13}\text{C}$  NMR (101 MHz,  $\text{CDCl}_3$ )  $\delta$  -9.8, 11.9, 18.0, 18.2, 114.5, 120.3, 121.8, 130.4, 136.7, 160.4. HRMS (m/z); 222.1438 (calcd for  $\text{C}_{13}\text{H}_{22}\text{OSi}$  222.1440).

2-(diisopropyl(methyl)silyl)phenyl trifluoromethanesulfonate (**98**)

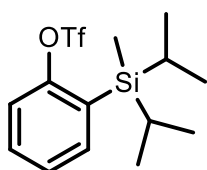

A 25 mL round bottom flask, equipped with a stir bar was charged with **97** (914 mg, 4.1 mmol, 1 equiv) and  $\text{Et}_2\text{O}$  was added (16 mL). The solution was cooled to  $0\text{ }^{\circ}\text{C}$  by a dry ice/acetone bath and *n*BuLi (1.9 mL, 2.2 M, 1 equiv) was then added slowly over 10 minutes. This solution was then stirred at  $0\text{ }^{\circ}\text{C}$  for 1 h before  $\text{Tf}_2\text{O}$  (0.68 mL, 4.1 mmol, 1 equiv) was added. The resulting solution was then allowed to warm to room temperature and  $\text{NH}_4\text{Cl}$  (30 mL) was added to stop the reaction. The layers were separated and the aqueous was extracted with hexanes (3 x 20 mL).



The organic layer was then washed with NaCl (2 x 30 mL). Then MgSO<sub>4</sub> was added and the solution was filtered through a Celite pad and concentrated in vacuo. The crude residue was then purified by column chromatography (100% hexanes) to yield the title compound as a colourless oil (1.39 g, 95%). R<sub>f</sub> 0.45 (hexanes); <sup>1</sup>H NMR (600 MHz, CDCl<sub>3</sub>); δ 0.31 (s, 3 H), 0.91 (d, *J* = 7.4 Hz, 6 H), 1.04 (d, *J* = 7.4 Hz, 6 H), 1.34 (sep, *J* = 7.4 Hz, 2 H), 7.33 (ddd, *J* = 1.2, 8.5, 7.4 Hz, 1 H), 7.37 (dd, *J* = 1.2 Hz, 8.5 Hz, 1 H), 7.44 (ddd, *J* = 2.0, 7.4, 8.5 Hz, 1 H), 7.52 (dd, *J* = 2.0, 7.4 Hz, 1 H). <sup>13</sup>C NMR (101 MHz, CDCl<sub>3</sub>) δ -10.0, 11.8, 17.9, 18.0, 118.5 (q, 320.5 Hz), 119.0, 127.0, 129.0, 131.0, 137.3, 155.6. <sup>19</sup>F NMR (376 MHz, CDCl<sub>3</sub>) δ -74.2.

(2-(5,5-dimethyl-1,3,2-dioxaborinan-2-yl)phenyl)diisopropyl(methyl)silane (**100**)

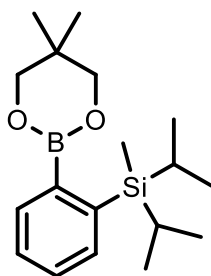

A 25 mL round bottom flask, equipped with a stir bar was charged with **98** (845 mg, 2.4 mmol, 1 equiv), bis(neopentylglycolato)diboron (598 mg, 2.6, 1.1 equiv), KOAc (729 mg, 7.4 mmol, 3 equiv), PdCl<sub>2</sub>(dppf) (118 mg, 0.14 mmol, 6 mol %) and dissolved in DMSO (8 mL). The solution was heated under argon at 80 °C for 18 h. This solution was then allowed to cool to room temperature and filtered through Celite with excess EtOAc. After rotary evaporation the solution was partitioned in water (5 mL) and EtOAc (6 mL). The organic layer was then washed with water (3 x 3 mL). Then MgSO<sub>4</sub> was added and the solution was filtered through a Celite pad and concentrated in vacuo. The crude residue was then purified by column chromatography (100% hexanes) to yield the title compound as a colourless oil (517 mg, 68%). R<sub>f</sub> 0.59 (9:1 hexanes/ethyl acetate); <sup>1</sup>H NMR (600 MHz, CDCl<sub>3</sub>); δ 0.20 (s, 3 H), 0.85 (d, *J* = 7.4 Hz, 6 H), 1.04-1.06 (m, 12 H), 1.34 (sep, *J* = 7.4 Hz, 2 H), 3.75 (s, 4 H), 7.29-7.36 (m, 2 H), 7.53-7.55 (m, 1 H), 7.73-7.75 (m, 1 H). <sup>13</sup>C NMR (101 MHz, CDCl<sub>3</sub>) δ -9.5, 12.6, 18.6, 18.8, 22.0, 31.6, 72.1, 127.4, 128.3, 133.6, 135.3, 142.2, 186.8. HRMS (*m/z*); 319.2253 (calcd for C<sub>18</sub>H<sub>31</sub>BO<sub>2</sub>Si+H<sup>+</sup> 319.2253).

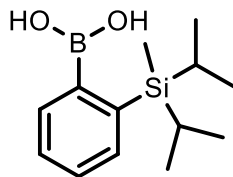
(2-(diisopropyl(methyl)silyl)phenyl)boronic acid (**102**)

The boronic ester **100** (359 mg, 1.1 mmol, 1 equiv) was dissolved in ether/isopropanol (50 mL/10 mL). Then DEA (248 mg, 2.4 mmol, 2.1 equiv) was added to the solution and it was stirred for 3.5 h. The solution was then concentrated in vacuo to give a white solid. This solid was then dissolved in ether and 1 M HCl acid was added and stirred for 12 h. The solution was then extracted with ether (3 x 5 mL). The organic layers were then combined and washed with brine (1 x 10 mL). Then MgSO<sub>4</sub> was added and the solution was filtered through a Celite pad. The crude product was obtained after rotary evaporation as an off white solid. *R<sub>f</sub>* 0.41 (9:1 hexanes/ethyl acetate); <sup>1</sup>H NMR (600 MHz, CDCl<sub>3</sub>); δ 0.23 (s, 3 H), 0.94 (d, *J* = 7.4 Hz, 6 H), 1.01 (t, *J* = 7.4 Hz, 6 H), 1.30 (sep, *J* = 7.4 Hz, 2 H), 6.67 (dd, *J* = 0.8, 8.6, 1 H), 6.92 (ddd, *J* = 1.2, 7.4, 8.6 Hz, 1 H), 7.23 (ddd, *J* = 0.8, 2.0, 7.0 Hz, 1 H), 7.33 (dd, *J* = 2.0, 7.4 Hz, 1 H). No <sup>13</sup>C NMR or HRMS data was recorded for this compound.

**General Benzosilole Reaction:** To a round bottom was charged 2-silylphenylboronic acid (0.5 equiv., 1 mmol), DABCO (1 equiv, 2 mmol), thiophene-acetylene species (2 equiv, 2 mmol), [RhCl(cod)]<sub>2</sub> (2.5 mol %, 0.05 mol), 1,4-dioxane (2 mL), and H<sub>2</sub>O (0.5 equiv, 1 mmol). The solution was then stirred for 1 day at 80 °C under argon. The reaction mixture was then filtered through a silica gel/ Celite bilayer pad using excess dichloromethane. This reaction was then concentrated under reduced pressure and purified by column chromatography.

1,1-dimethyl-2,3-di(thiophen-2-yl)-1H-benzo[b]silole (**106**)

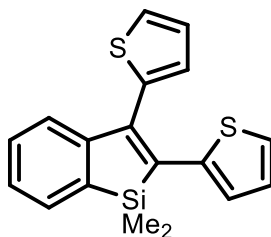

The general benzosilole procedure was followed with bis(thiophene)ethyne (186 mg, 0.98 mmol, 2 equiv), 2-trimethylsilylphenylboronic acid (102 mg, 0.52 mmol, 1 equiv), DABCO (112 mg, 1.1 mmol, 2 equiv),  $[\text{RhCl}(\text{cod})]_2$  (29 mg, 0.06 mmol, 6 mol %),  $\text{H}_2\text{O}$  (0.02 mL), in 1,4-dioxane (2.5 mL) for 26 h to afford **106** as pale yellow solid (40 mg, 24%).  $R_f$  0.32 (hexanes) The  $^1\text{H}$  NMR data and IR data for this compound is consistent with previously reported literature values.<sup>76</sup>

2,3-di([2,2'-bithiophen]-5-yl)-1,1-dimethyl-1H-benzo[b]silole (**107**)

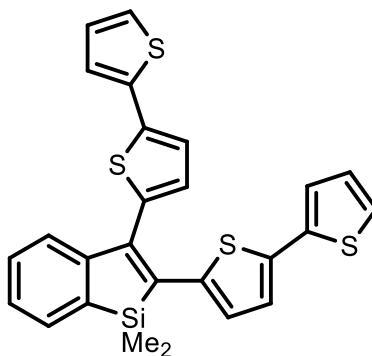

The general benzosilole procedure was followed with bis(dithiophene)ethyne (322 mg, 0.9 mmol, 2 equiv), 2-trimethylsilylphenylboronic acid (88 mg, 0.45 mmol, 1 equiv), DABCO (56 mg, 0.5 mmol, 1.1 equiv),  $[\text{RhCl}(\text{cod})]_2$  (14 mg, 0.03 mmol, 3 mol %),  $\text{H}_2\text{O}$  (0.01 mL), in 1,4-dioxane (1 mL) for 18 h to afford **107** as a bright yellow solid (50 mg, 23%).  $R_f$  0.32 (4:1 hexanes/ethyl acetate);  $^1\text{H}$  NMR (600 MHz,  $\text{CDCl}_3$ );  $\delta$  0.57 (s, 6 H), 7.04 (dd,  $J = 3.9, 5.0$  Hz, 3 H), 7.12-7.16 (m, 2 H), 6.92-6.96 (m, 3 H), 7.23-7.26 (m, 3 H), 7.31-7.35 (m, 2 H), 7.59 (d,  $J = 7.0$  Hz, 1 H).  $^{13}\text{C}$  NMR (101 MHz,  $\text{CDCl}_3$ )  $\delta$  -2.7, 123.1, 123.7, 123.8, 124.4, 124.47, 126.8, 127.8, 127.8, 129.0, 129.1, 130.4, 131.5, 136.1, 136.5, 137.4, 138.7, 139.1, 139.4, 141.4, 141.6, 151.2. IR (KBr): 2955

m, 2924 s, 2952 m, 1580 w, 1433 m, 1250 m, 1061 m, 1040 m, 843 m, 800 s, 690 s. HRMS (m/z); 488.0212 (calcd for C<sub>26</sub>H<sub>20</sub>S<sub>4</sub>Si 488.0217).

2,3-di([2,2':5',2''-terthiophen]-5-yl)-1,1-dimethyl-1H-benzo[b]silole (**108**)

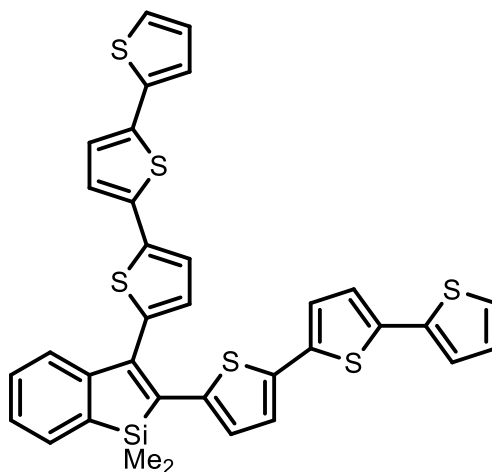

The general benzosilole procedure was followed with crude bis(terthiophene)ethyne (767 mg, 1.5 mmol, 2 equiv), 2-trimethylsilylphenylboric acid (141 mg, 0.73 mmol, 1 equiv), DABCO (163 mg, 1.5 mmol, 2 equiv), [RhCl(cod)]<sub>2</sub> (23 mg, 0.05 mmol, 3 mol %), H<sub>2</sub>O (0.02 mL), in 1,4-dioxane (3 mL) for 1.5 days to afford **108** as a bright orange solid (15 mg, 3%). R<sub>f</sub> 0.44 (7:3 hexanes/dichloromethane); <sup>1</sup>H NMR (400 MHz, CDCl<sub>3</sub>); δ 0.57 (s, 6 H), 6.94 (d, *J* = 4.11, 1 H), 6.95-6.96 (m, 2 H), 6.99 (dd, *J* = 4.11, 5.28, 1 H), 7.02 (d, *J* = 4.11 Hz, 1 H), 7.03-7.05 (m, 1 H), 7.12 (d, *J* = 3.5 Hz, 1 H), 7.13-7.15 (m, 3 H), 7.19 (dd, *J* = 1.2, 5.3 Hz, 1 H), 7.21 (dd, *J* = 1.2, 3.5 Hz, 1 H), 7.24 (d, *J* = 4.7 Hz, 1 H), 7.25-7.26 (m, 1 H), 7.32 (d, *J* = 3.5 Hz, 1 H), 7.34 (ddd, *J* = 1.2, 7.6, 8.8 Hz, 1 H), 7.60 (d, *J* = 7.0 Hz, 1 H). <sup>13</sup>C NMR (101 MHz, CDCl<sub>3</sub>) δ -2.7, 123.11, 123.7, 123.7, 123.8, 124.4, 124.4, 124.4, 124.5, 124.5, 126.8, 127.8, 127.9, 129.2, 129.3, 130.4, 131.5, 136.2, 136.2, 136.2, 136.3, 136.3, 136.7, 137.1, 137.2, 138.4, 139.1, 139.2, 141.6, 141.7, 151.1. IR (KBr); 2957 s, 2924 s, 2854 s, 1580 w, 1460 m, 1423 m, 1261 w, 1101 w, 1038 m, 835 m, 793 s, 690 m. HRMS (m/z); 651.9946 (calcd for C<sub>34</sub>H<sub>24</sub>S<sub>6</sub>Si 651.9972).

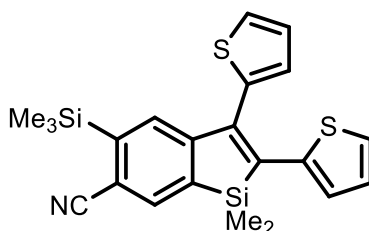
1,1-dimethyl-2,3-di(thiophen-2-yl)-5-(trimethylsilyl)-1H-benzo[b]silole-6-carbonitrile (**109**)

The general benzosilole procedure was followed with bis(thiophene)ethyne (371 mg, 2.0 mmol, 2 equiv), (4-cyano-2,5-bis(trimethylsilyl)phenyl)boronic acid (350 mg, 0.96 mmol, 1 equiv), DABCO (218 mg, 1.9 mmol, 2 equiv), [RhCl(cod)]<sub>2</sub> (26 mg, 0.05 mmol, 2.5 mol %), H<sub>2</sub>O (0.02 mL), in 1,4-dioxane (3 mL) for 24 h to afford **109** as an orange solid (104 mg, 28%). *R*<sub>f</sub> 0.19 (4:1 hexanes/dichloromethane); <sup>1</sup>H NMR (400 MHz, CDCl<sub>3</sub>); δ 0.35 (s, 9 H), 0.61 (s, 6 H), 7.00-7.04 (m, 2 H), 7.08 (dd, *J* = 0.8, 3.5 Hz, 1 H), 7.20 (s, 1 H), 7.27 (d, *J* = 1.2 Hz, 1 H), 7.28 (s, 1 H), 7.62 (dd, *J* = 1.2, 5.1 Hz, 1 H), 7.86 (s, 1H). <sup>13</sup>C NMR (101 MHz, CDCl<sub>3</sub>) δ -3.1, -1.9, 114.6, 120.7, 126.4, 127.7, 128.1, 128.3, 128.4, 128.8, 129.2, 135.8, 136.6, 137.2, 141.2, 141.7, 142.7, 147.4, 153.7. IR (KBr): 2962 w, 2924 w, 2899 w, 2852 w, 2212 s, 1574 m, 1410 m, 1248 s, 1099 m, 841 s, 788 m, 698 m. HRMS (*m/z*); 421.0812 (calcd for C<sub>22</sub>H<sub>23</sub>NS<sub>2</sub>Si<sub>2</sub> 421.0810).

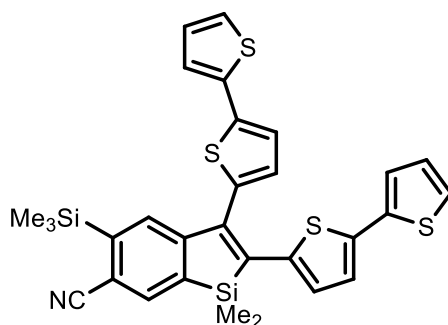
2,3-di([2,2'-bithiophen]-5-yl)-1,1-dimethyl-5-(trimethylsilyl)-1H-benzo[b]silole-6-carbonitrile (**110**)

The general benzosilole procedure was followed with excess bis(bithiophene)ethyne, (4-cyano-2,5-bis(trimethylsilyl)phenyl)boronic acid (240 mg, 0.82 mmol, 1 equiv), DABCO (193 mg, 1.7 mmol, 2 equiv), [RhCl(cod)]<sub>2</sub> (24 mg, 0.05 mmol, 6 mol %), H<sub>2</sub>O (0.02 mL), in 1,4-dioxane (3

mL) for 2 days to afford **110** as an orange solid (49 mg, 10%).  $R_f$  0.43 (8.5:1.5 hexanes/EtOAc);  $^1\text{H}$  NMR (400 MHz,  $\text{CDCl}_3$ );  $\delta$  0.33 (s, 9 H), 0.57 (s, 6 H), 6.92 (dd,  $J = 0.8, 3.5$  Hz, 1 H), 6.94 (dd,  $J = 0.8, 3.9$  Hz, 1 H), 6.97 (d,  $J = 3.5$  Hz, 1 H), 7.02-7.07 (m, 3 H), 7.16 (dd,  $J = 0.8, 5.1$  Hz, 1 H), 7.23-7.25 (m, 2 H), 7.30 (s, 1H), 7.32 (d,  $J = 3.5$  Hz, 1 H), 7.82 (s, 1 H).  $^{13}\text{C}$  NMR (101 MHz,  $\text{CDCl}_3$ )  $\delta$  -3.0, -1.5, 114.6, 120.6, 123.3, 124.0, 124.2, 124.5, 124.6, 124.9, 127.9, 127.9, 128.8, 129.3, 130.4, 135.2, 135.8, 137.1, 137.2, 137.2, 139.9, 140.1, 140.4, 140.6, 142.8, 147.6, 153.4. IR (KBr): 2951 w, 2926 w, 2897 w, 2854 w, 2214 m, 1574 m, 1441 m, 1250 m, 1097 m, 839 s, 798 m, 692 m. HRMS (m/z); 585.0562 (calcd for  $\text{C}_{30}\text{H}_{27}\text{NS}_4\text{Si}_2$  585.0565).

2,3-di([2,2':5',2''-terthiophen]-5-yl)-1,1-dimethyl-5-(trimethylsilyl)-1H-benzo[b]silole-6-carbonitrile (**111**)

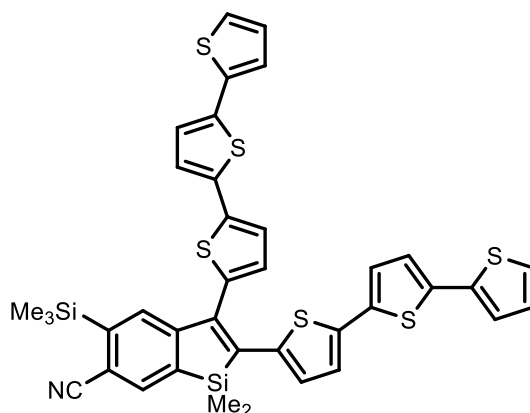

The general benzosilole procedure was followed with crude bis(terthiophene)ethyne (237 mg, 0.46 mmol, 2 equiv), (4-cyano-2,5-bis(trimethylsilyl)phenyl)boronic acid (74 mg, 0.25 mmol, 1 equiv), DABCO (38 mg, 0.39 mmol, 2 equiv),  $[\text{RhCl}(\text{cod})]_2$  (13 mg, 0.03 mol, 10 mmol %),  $\text{H}_2\text{O}$  (0.01 mL), in 1,4-dioxane (2 mL) for 3 days to afford **111** as a bright orange solid (12 mg, 6%).  $R_f$  32 (7:3 hexanes/dichloromethane);  $^1\text{H}$  NMR (400 MHz,  $\text{CDCl}_3$ );  $\delta$  0.35 (s, 9 H), 0.60 (s, 6 H), 6.95-6.96 (m, 1 H), 6.98 (d,  $J = 3.5$  Hz, 1 H), 6.99-7.01 (m, 2 H), 7.02 (d,  $J = 3.5$  Hz, 1 H), 7.04 (dd,  $J = 1.2, 4.7$  Hz, 1 H), 7.06 (d,  $J = 3.5$  Hz, 1 H), 7.13 (d,  $J = 3.5$  Hz, 1 H), 7.15 (dd,  $J = 1.2, 3.5$  Hz, 1 H), 7.16 (d,  $J = 3.5$  Hz, 1 H), 7.20 (dd,  $J = 5.3, 1.1$  Hz, 1 H), 7.22 (dd,  $J = 3.5, 1.2$  Hz, 1 H), 7.25 (dd,  $J = 5.3, 1.2$  Hz, 1 H), 7.31 (s, 1 H), 7.34 (d,  $J = 3.5$  Hz, 1 H), 7.84 (s, 1 H).  $^{13}\text{C}$  NMR (101

MHz, CDCl<sub>3</sub>)  $\delta$  -3.0, -1.50, 114.7, 120.7, 123.2, 123.8, 123.9, 124.4, 124.5, 124.6, 124.7, 124.9, 127.9, 127.9, 128.8, 129.5, 135.4, 135.8, 135.9, 135.9, 136.0, 136.6, 136.9, 137.0, 137.0, 137.2, 139.7, 139.8, 140.4, 140.7, 142.8, 147.6, 153.3. IR (KBr): 2952 s, 2924 s, 2854 s, 2214 m, 1575 m, 1464 w, 1441 w, 1099 w, 839 s, 793 s, 692 w. HRMS (m/z); 749.0319 (calcd for C<sub>38</sub>H<sub>31</sub>NS<sub>6</sub>Si 749.0319).

(1,1-dimethyl-2,3-di(thiophen-2-yl)-5-(trimethylsilyl)-1H-benzo[b]silol-6-yl)methanamine (**115**)

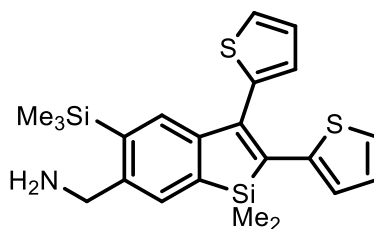

A 10 mL flask, equipped with a stir bar was charged with NaBH<sub>4</sub> (71 mg, 1.9 mmol, 9 equiv) and suspended in THF (1 mL). Then TFA (1 mL, 13 mmol) was dissolved in THF (2.5 mL) in another 10 mL flask. Of this 5.2 M solution, 0.36 mL was taken and added dropwise to the NaBH<sub>4</sub> suspension at room temperature. The solution was stirred for 15 min and then **109** (87 mg, 0.21 mmol, 1 equiv) in THF (2.5 mL) was added dropwise. This was then stirred for room temperature for 2 h followed by adding H<sub>2</sub>O and EtOAc and separating the layers. The organic layer was dried with MgSO<sub>4</sub>, filtered through Celite, and evaporated in vacuo. This residue was purified by column chromatography (8:2 hexanes/EtOAc) to yield a yellow solid (24 mg, 27%). R<sub>f</sub> 0.33 (15% EtOAc in hexanes); <sup>1</sup>H NMR (600 MHz, CDCl<sub>3</sub>);  $\delta$  0.28 (s, 9 H), 0.57 (s, 6 H), 3.75 (br, 2 H), 4.04-4.07 (m, 2 H), 6.97 (dd, *J* = 4.1, 5.3 Hz, 1 H), 7.00 (dd, *J* = 1.2, 3.5 Hz, 1 H), 7.02 (dd, *J* = 4.1, 1.2 Hz, 1 H), 7.16 (s, 1 H), 7.20 (dd, *J* = 1.2, 4.1 Hz, 1 H), 7.24 (dd, *J* = 3.5, 5.3 Hz, 1 H), 7.53 (s, 1 H), 7.58 (dd, *J* = 1.2, 5.3 Hz, 1H). <sup>13</sup>C NMR (101 MHz, CDCl<sub>3</sub>)  $\delta$  -2.9, 0.1, 53.4, 126.3, 127.4, 127.5, 128.0, 128.1, 128.4, 129.9, 132.2, 137.2, 138.8, 139.5, 139.8, 141.5, 141.8, 142.1, 151.0. IR (KBr): 3261 s, 3230 m, 2957 m, 2924 m, 2852 w, 1583 s, 1454 w, 1416 w, 1365 m, 1252 s, 1169 s, 1101 s, 1038 m, 839 s, 777 s, 690 s. HRMS (m/z); 425.1129 (calcd for C<sub>22</sub>H<sub>27</sub>NS<sub>2</sub>Si<sub>2</sub> 425.1123).

## References

---

- <sup>1</sup> Yamaguchi, S.; Tamao, K. *J. Chem. Dalton Trans.* **1998**, 3693-3702.
- <sup>2</sup> Tamao, K.; Yamaguchi, S.; Ito, Y.; Matsuzaki, Y.; Yamabe, T.; Fukushima, M.; Mori, S. *Macromolecules.* **1995**, *28*, 8668-8675.
- <sup>3</sup> Braye, E.; Hubel, W. *Chem. Ind. (London)*, **1959**, 1250.
- <sup>4</sup> Hermanns, J.; Schmidt, B. *J. Chem. Soc., Perkins Trans.* **1999**, *1*, 81-102.
- <sup>5</sup> Tamao, K.; Yamaguchi, S.; Shiro, M. *J. Am. Chem. Soc.* **1994**, *116*, 11715-11722.
- <sup>6</sup> Chen, W.; Ijadi-Maghsoudi, S.; Barton, T. *Polym. Prepr. (Am. Chem. Soc., Div. Polym. Chem.)* **1997**, *38*, 189.
- <sup>7</sup> Moroni, M.; Le Moigne, J.; Luzzati, S. *Macromolecules* **1994**, *27*, 562-571.
- <sup>8</sup> Pang, Y.; Wang, Z.; Barton, T. *Polym. Prepr. (Am. Chem. Soc., Div. Polym. Chem.)* **1996**, *37*, 333.
- <sup>9</sup> Yamaguchi, S.; Iimura, K.; Tamao, K. *Chem. Lett.* **1998**, 89-90.
- <sup>10</sup> Yamaguchi, S.; Endo, T.; Echida, M.; Izumizawa, T. Furukawa, K.; Tamao, K. *Chem. Eur. J.* **2000**, *6*, 1683-1692.
- <sup>11</sup> Boydston, A. J.; Yin, Y.; Pagenkopf, L. B. *J. Am. Chem. Soc.* **2004**, *126*, 3724-3725.
- <sup>12</sup> Boydston, A. J.; Yin, Y.; Pagenkopf, L. B. *J. Am. Chem. Soc.* **2004**, *126*, 10350-10354.
- <sup>13</sup> Ding, C.; Babu, G.; Orita, A.; Hirate, T.; Otera, J. *Synlett* **2007**, *16*, 2559-2563.
- <sup>14</sup> Boydston, A. J.; Pagenkopf, B. L. *Angew. Chem. Int. Ed.* **2004**, *43*, 6336-6338.
- <sup>15</sup> Booker, C.; Wang, X.; Haroun, S.; Jigang, Z.; Jennings, M.; Pagenkopf, B. L.; Ding, Z. *Angew. Chem. Int. Ed.* **2008**, *47*, 7731-7735.
- <sup>16</sup> Morra, N. A.; Pagenkopf, B. *Org. Syn.* **2008**, *85*, 53-63.
- <sup>17</sup> Dubac, J.; Laporterie, A.; Manuel, G. *Chem. Rev.* **1990**, *90*, 215-263.
- <sup>18</sup> Shimizu, M.; Mochida, K.; Katoh, M.; Hiyama, T. *J. Phys. Chem. C.* **2010**, *114*, 10004-10014.
- <sup>19</sup> Liu, J.; Cheng, Y.; Xie, Z.; Geng, Y.; Wang, L.; Jing, X.; Wang, F. *Adv. Mater.* **2008**, *20*, 1357-1362.
- <sup>20</sup> Van Klink, G. P. M.; de Boer, H. J. R.; Schat, G.; Akkerman, O. S.; Bickelhaupt, F.; Spek, A. *Organometallics* **2002**, *21*, 2119-2135.
- <sup>21</sup> Wang, Z.; Fang, H.; Xi, Z. *Tetrahedron Lett.* **2005**, *46*, 499-501.



- 
- <sup>22</sup> Matsuda, T.; Yamaguchi, Y.; Shigeno, M.; Sato, S.; Murakami, M. *Chem. Commun.* **2011**, *47*, 8697-8699.
- <sup>23</sup> Matsuda, T.; Kadowski, S.; Yamaguchi, Y.; Murakami, M. *Chem. Commun.* **2008**, 2744-2746.
- <sup>24</sup> Ilies, L.; Tsuji, H.; Sato, Y.; Nakamura, E. *J. Am. Chem. Soc.* **2008**, *130*, 4240-4241.
- <sup>25</sup> Ilies, L.; Tsuji, H.; Nakamura, E. *Org. Lett.* **2009**, *11*, 3966-3968.
- <sup>26</sup> Tamao, K.; Kawachi, A. *Adv. Organomet. Chem.* **1995**, *38*, 1-58.
- <sup>27</sup> Tobisu, M.; Kita, Y.; Ano, Y.; Chatani, N. *J. Am. Chem. Soc.* **2008**, *130*, 15982-15989.
- <sup>28</sup> Ojima, I.; Fracchiolla, D. A.; Donovan, R. J.; Banerji, P. *J. Org. Chem.* **1994**, *59*, 7594-7595.
- <sup>29</sup> Tobisu, M.; Onoe, M.; Kita, Y.; Chatani, K. *J. Am. Chem. Soc.* **2009**, *131*, 7506-7507.
- <sup>30</sup> Lan, Y.; Yu, Z. *J. Org. Chem.* **2013**, *78*, 11501-11507.
- <sup>31</sup> Sohn, H.; Sailor, M.; Magde, D.; Trogler, T. *J. Am. Chem. Soc.* **2003**, *125*, 3821-3830.
- <sup>32</sup> Peng, L.; Wang, M.; Zhang, G.; Zhang, D.; Zhu, D. *Org. Lett.* **2009**, *11*, 1943-1946.
- <sup>33</sup> Wang, M.; Zhang, D.; Zhang, G.; Tang, Y.; Wang, S.; Zhu, D. *Anal. Chem.* **2008**, *80*, 6443-6448.
- <sup>34</sup> Luo, J.; Xie, Z.; Lam, J.; Cheng, L.; Tang, B.; Chen, H.; Qiu, C.; Kwok, H.; Zhan, X.; Liu, Y.; Zhu, D. *Chem. Commun.* **2001**, 1740-1741.
- <sup>35</sup> Chen, J.; Law, C.; Lam, J.; Dong, Y.; Lo, S.; Williams, I.; Zhu, D.; Tang, B. *Chem. Mater.* **2003**, *79*, 1535.
- <sup>36</sup> Hong, Y.; Lam, J.; Tang, B. *Chem. Soc. Rev.* **2011**, *40*, 5361.
- <sup>37</sup> Zhao, E.; Lam, J.; Hong, Y.; Liu, J.; Peng, Q.; Hao, J.; Sung, H.; Williams, I.; Tang, B. *J. Mater. Chem. C* **2013**, *1*, 5661-5668.
- <sup>38</sup> Young, C.; Tidwell, L.; Anderson, C. *Cyanide: Social, Industrial, and Economic Aspects*; Minerals, Metals, and Materials Society: Warrendale, 2001.
- <sup>39</sup> Peng, L.; Wang, M.; Zhang, G.; Zhang, D.; Zhu, D. *Org. Lett.* **2009**, *11*, 1943-1946.
- <sup>40</sup> Hong, Y.; Lam, J.; Tang, B. *Chem. Soc. Rev.* **2011**, *40*, 5361.
- <sup>41</sup> Chen, L.; Jiang, Y.; Nie, H.; Lu, P.; Sung, H.; Williams, D.; Kwok, H.; Huang, F.; Qin, A.; Zhao, Z.; Tang, B. *Adv. Funct. Mater.* **2014**, *24*, 3621-3630.
- <sup>42</sup> Sohn, H.; Sailor, M.; Magde, D.; Trogler, W. *J. Am. Chem. Soc.* **2003**, *125*, 3821-3830.
- <sup>43</sup> Zhao, Y.; Hao, W.; Ma, W.; Zang, Z.; Zhang, H.; Liu, X.; Zou, S.; Zhang, H.; Liu, W.; Gao, J. *New J. Chem.* **2014**, *38*, 5754-5760.
- <sup>44</sup> Liu, Z.; Liu, J.; Cai, P.; Chen, J. *Disp. Tech.* **2013**, *9*, 490-496.

- 
- <sup>45</sup> Toal, S.; Jones, K.; Magde, D. Trogler, W. *J. Am. Chem. Soc.* **2005**, *127*, 11661-11665.
- <sup>46</sup> Ko, S.; Choi, K.; Kang, M. S.; Hwang, H.; Ji, H.; Kim, J.; Ko, J.; Kang, Y. *J. Mater. Chem.* **2010**, *20*, 2391-2399.
- <sup>47</sup> Matsumoto, T.; Urano, Y.; Shoda, T.; Kojima, H.; Nagano, T. *Org. Lett.* **2007**, *9*, 3375-3377.
- <sup>48</sup> Valeur, B. *Molecular Fluorescence: Principles and Applications*, Wiley-VCH, Weinham, **2002**, 351-378.
- <sup>49</sup> Nakajima, N.; Ikada, Y. *Bioconjugate Chem.* **1995**, *6*, 123-130.
- <sup>50</sup> Binder, W. H.; Kluger, C. *Curr. Org. Chem.* **2006**, *10*, 1791-1815.
- <sup>51</sup> Ulrich, G.; Goze, C.; Guardigli, M.; Roda, A.; Ziessel, R. *Angew. Chem. Int. Ed.* **2005**, *44*, 3694-3698.
- <sup>52</sup> Qiu, D.; Mo, F.; Zheng, Z.; Zhang, Y.; Wang, J. *Org. Lett.* **2010**, *12*, 5474-5477.
- <sup>53</sup> Ihara, H.; Suginome, M. *J. Am. Chem. Soc.* **2009**, *131*, 7502-7503.
- <sup>54</sup> Kauch, M.; Hoppe, D. *Can J. Chem.* **2001**, *79*, 1736-1746.
- <sup>55</sup> Mesganaw, T.; Garg, B. *Org. Process Res. Dev.* **2013**, *17*, 29-39.
- <sup>56</sup> Baron, O.; Knochel, P. *Angew. Chem. Int. Ed.* **2005**, *44*, 3133-3135.
- <sup>57</sup> Dabrowski, M.; Kurach, P.; Lulinski, S.; Serwatowski, J. *Appl. Organometal. Chem.* **2007**, *21*, 234-238.
- <sup>58</sup> *Handbook of Oligo- and Polythiophenes*; Fichou, D., Ed.; Wiley-VCH: Weinheim, 1999.
- <sup>59</sup> Geiger, F.; Stoldt, M.; Schweizer, H.; Bauerle, P.; Umbach, E. *Adv. Mater.* **1993**, *5*, 922-925.
- <sup>60</sup> Noma, N.; Tsuzuki, T.; Shirota, Y. *Adv. Mater.* **1995**, *7*, 647-648.
- <sup>61</sup> Holiday, B. J.; Swagger, T. M. *Chem. Commun.* **2005**, 23-36.
- <sup>62</sup> Rockel, H.; Huber, J.; Gleiter, R.; Schuhman, W. *Adv. Mater.* **1994**, *6*, 568-571.
- <sup>63</sup> Mishra, A.; Ma, C. Q.; Bauerle, P. *Chem. Rev.* **2009**, *109*, 1141-1276.
- <sup>64</sup> Tamao, K.; Sumitani, K.; Kumada, M. *J. Am. Chem. Soc.* **1972**, *94*, 4374-4376.
- <sup>65</sup> Yoshikai, N.; Matsuda, H.; Nakamura, E. *J. Am. Chem. Soc.* **2009**, *131*, 9590-9599.
- <sup>66</sup> Wu, R.; Schumm, J. S.; Pearson, D. L.; Tour, J. M. *J. Org. Chem.* **1996**, *61*, 6906-6921.
- <sup>67</sup> Xia, P. F.; Feng, X. J.; Lu, J.; Molveanu, R.; Tao, Y.; Baribeau, J. M.; Wong, M. S. *J. Phys. Chem. C* **2008**, *112*, 16714-16720.
- <sup>68</sup> Boas, U.; Dhanabalan, A.; Greve, D. R.; Meijer, E. W. *Synlett* **2001**, *5*, 634-636.
- <sup>69</sup> Kwok, E. C.; Chan, M.; Wong, K. M.; Lam, W. H.; Yam, V. W. *Chem. Eur. J.* **2010**, *16*, 12244-12254.

- 
- <sup>70</sup> Zhao, X.; Piliego, C.; Kim, B.; Poulsen, D. A.; Ma, B.; Unruh, D. A.; Frechet, J. M. J. *Chem. Mater.* **2010**, *22*, 2325-2332.
- <sup>71</sup> Mio, M. J.; Kopel, L. C.; Braun, J. B.; Gadzikwa, T. L.; Hull, K. L.; Brisbois, R. G.; Markworth, C. J.; Greico, P. A. *Org. Lett.* **2002**, *4*, 3199-3202.
- <sup>72</sup> Bao, R. L.; Zhao, R.; Shi, L. *Chem. Comm.* **2015**, *51*, 6884-6900.
- <sup>73</sup> Murakami, K.; Yorimitsu, H.; Oshima, K. *J. Org. Chem.* **2009**, *74*, 1415-1417.
- <sup>74</sup> Bettinger, H. F.; Filthaus, M. *J. Org. Chem.* **2007**, *72*, 9750-9752.
- <sup>75</sup> Onoe, M.; Baba, K.; Kim, Y.; Kita, Y.; Tobisu, M.; Chatani, N. *J. Am. Chem. Soc.* **2012**, *134*, 19477-19488.
- <sup>76</sup> Masaoka, S.; Banno, T.; Ishikawa, M. *J. Organomet. Chem.* **2006**, *691*, 174-181.
- <sup>77</sup> Kira, M.; Iwamoto, T.; Maruyama, T.; Kuzuguchi, T.; Yin, D.; Kabuto, C.; Sakurai, H. *J. Chem. Soc., Dalton Trans.* **2002**, 1539-1544.
- <sup>78</sup> Julich-Gruner, K. K.; Kataeva, O.; Schmidt, A. W.; Knolker, H. J. *Chem. Eur. J.* **2014**, *20*, 8536-8540.
- <sup>79</sup> Esguerra, K. V. N.; Fall, Y.; Petitjean, L.; Lumb, J. P. *J. Am. Chem. Soc.* **2014**, *136*, 7662-7668.
- <sup>80</sup> Mori, Y.; Futamura, Y.; Horisaki, K. *Angew Chem. Int. Ed.* **2008**, *47*, 1091-1093.
- <sup>81</sup> Shimizu, M.; Mochida, K.; Hiyama, T. *Angew. Chem. Int. Ed.* **2008**, *47*, 9760-9764.
- <sup>82</sup> Murata, M.; Oyama, T.; Watanabe, S.; Musada, Y. *J. Org. Chem.* **2000**, *65*, 164-168.
- <sup>83</sup> Thomson, A. L. S.; Kabalka, G. W.; Akula, M. R.; Huffman, J. W. *Synthesis*, **2005**, 547-550.
- <sup>84</sup> Green, A. E. Agouridas, V.; Deniau, E. *Tetrahedron Lett.* **2013**, *54*, 7078-7079.
- <sup>85</sup> Zhang, Y.; Gao, X.; Hardcastle, K.; Wang, B. *Chem. Eur. J.* **2006**, *12*, 1377-1384.
- <sup>86</sup> Sessions, E. H.; Jacobi, P. A. *Org. Lett.* **2006**, *8*, 4125-4128.
- <sup>87</sup> Martichonok, V.; Jones, J. B. *J. Am. Chem. Soc.* **1996**, *118*, 950-958.
- <sup>88</sup> Sun, J.; Perfetti, M. T.; Santos, W. L. *J. Org. Chem.* **2011**, *76*, 3571-3575.
- <sup>89</sup> Lulinski, S.; Serwatowski, J. *J. Org. Chem.* **2003**, *68*, 9384-9388.
- <sup>90</sup> Bornschein, C.; Werkmeister, S.; Junge, K.; Beller, M. *New J. Chem.* **2013**, *37*, 2061-2065.
- <sup>91</sup> Rao, C. N.; Hoz, S. *J. Org. Chem.* **2012**, *77*, 4029-4034.
- <sup>92</sup> Addis, D.; Enthaler, S.; Junge, K.; Wendt, B.; Beller, M. *Tetrahedron Lett.* **2009**, *50*, 3654-3656.
- <sup>93</sup> Khurana, J. M.; Kukreja, G. *Synth. Commun.* **2002**, *32*, 1265-1269.

- 
- <sup>94</sup> Barbero, N.; Martin, R. *Org. Lett.* **2012**, *14*, 796-799.
- <sup>95</sup> Nystrom, R. F.; Brown, W. G. *J. Am. Chem. Soc.* **1947**, *69*, 3738-3740.
- <sup>96</sup> Pasumansky, L.; Haddenham, D.; Clary, J. W.; Fisher, G. B.; Goralski, C. T.; Singaram, B. *J. Org. Chem.* **2008**, *73*, 1898-1905.
- <sup>97</sup> Haddenham, D.; Pasumansky, L.; DeSoto, J.; Eagon, S.; Singaram, B. *J. Org. Chem.* **2009**, *74*, 1964-1970.
- <sup>98</sup> Umino, N.; Iwakuma, T.; Itoh, N. *Tetrahedron Lett.* **1976**, 2875-2876.
- <sup>99</sup> Gribble, G. W. *Chem. Soc. Rev.* **1998**, *27*, 395-404.
- <sup>100</sup> Hercules, D. M. *Science* **1964**, *145*, 808.
- <sup>101</sup> Santhanam, K. S. V.; Bard, A. J. *J. Am. Chem. Soc.* **1965**, *87*, 139.
- <sup>102</sup> Miao, W. *Chem. Rev.* **2008**, *108*, 2506-2553.
- <sup>103</sup> *IUPAC Compendium of Chemical Terminology*, 2<sup>nd</sup> ed.; McNaught, A. D., Wilkinson, A., Eds.; Blackwell Science: Oxford, U.K., 1997.
- <sup>104</sup> Richter, M. M. *Chem. Rev.* **2004**, *104*, 3003-3036.
- <sup>105</sup> Sartin, M. M.; Boydston, A. J.; Pagenkopf, B. L.; Bard, A. J. *J. Am. Chem. Soc.* **2006**, *128*, 10163-10170.
- <sup>106</sup> Pusztai, E.; Touloukhonova, I. S.; Temple, N.; Albright, H.; Zakai, U. I.; Guo, S.; Guzei, I. A.; Hu, R.; West, R. *Organometallics* **2013**, *32*, 2529-2535.
- <sup>107</sup> Miao, W.; Bard, A. J. *Anal. Chem.* **2004**, *76*, 5379-5386.
- <sup>108</sup> Armarego, W. L. F.; Perrin, D. D. *Purification of Laboratory Chemicals*; 4<sup>th</sup> Ed.; Oxford; Boston: Butterworth Heinemann, 1996.
- <sup>109</sup> See footnote 50 in: Gao, Y.; Hanson, R. M.; Klunder, J. M.; Ko, S. Y.; Masamune, H.; Sharpless, K. B. *J. Am. Chem. Soc.* **1987**, *109*, 5765-5780.
- <sup>110</sup> Still, W. C.; Kahn, M.; Mitra, A. *J. Org. Chem.* **1978**, *43*, 2923-2925.
- <sup>111</sup> Quasdorf, K. W.; Reiner, M.; Petrova, K. K.; Garg, N. K. *J. Am. Chem. Soc.* **2009**, *131*, 17748-17749.
- <sup>112</sup> Sibi, M. P.; Snieckus, V. *J. Org. Chem.* **1983**, *48*, 1935-1937.
- <sup>113</sup> Scheuble, M.; Gross, Y. M.; Trefz, D.; Brinkmann, M.; Navarrete, J. T. L.; Delgado, M. C. R.; Ludwigs, S. *Macromolecules* **2015**, *48*, 7049-7059.
- <sup>114</sup> Frigoli, M.; Moustrou, C.; Samat, A.; Guglielmetti, R. *Helv. Chim. Acta* **2000**, *83*, 3043-3052.

- 
- <sup>115</sup> Grubel, M.; Meister, S.; Schulze, U.; Raftopoulos, K. N.; Baumer, F.; Papadakis, C. M.; Nilges, T.; Rieger, B. *Macromol. Chem. Phys.* **2016**, *217*, 59-71.
- <sup>116</sup> Liang, Y.; Geng, W.; Wei, J.; Xi, Z. *Angew. Chem. Int. Ed.* **2012**, *51*, 1934-1937.
- <sup>117</sup> Krasovskiy, A.; Knochel, P. *Angew. Chem. Int. Ed.* **2004**, *43*, 3333-3336.
- <sup>118</sup> Yeh, M. C. P.; Chen, H. G.; Knochel, P. *Org. Synth.* **1992**, *70*, 195.
- <sup>119</sup> Krompiec, S.; Filapek, M.; Grudzka, I.; Kula, S.; Slodek, A.; Skorka, L.; Danikiewicz, W.; Ledwon, P.; Lapkowski, M. *Synthetic Metals* **2013**, *165*, 7-16.

---

## **Appendix I NMR Spectral Data**

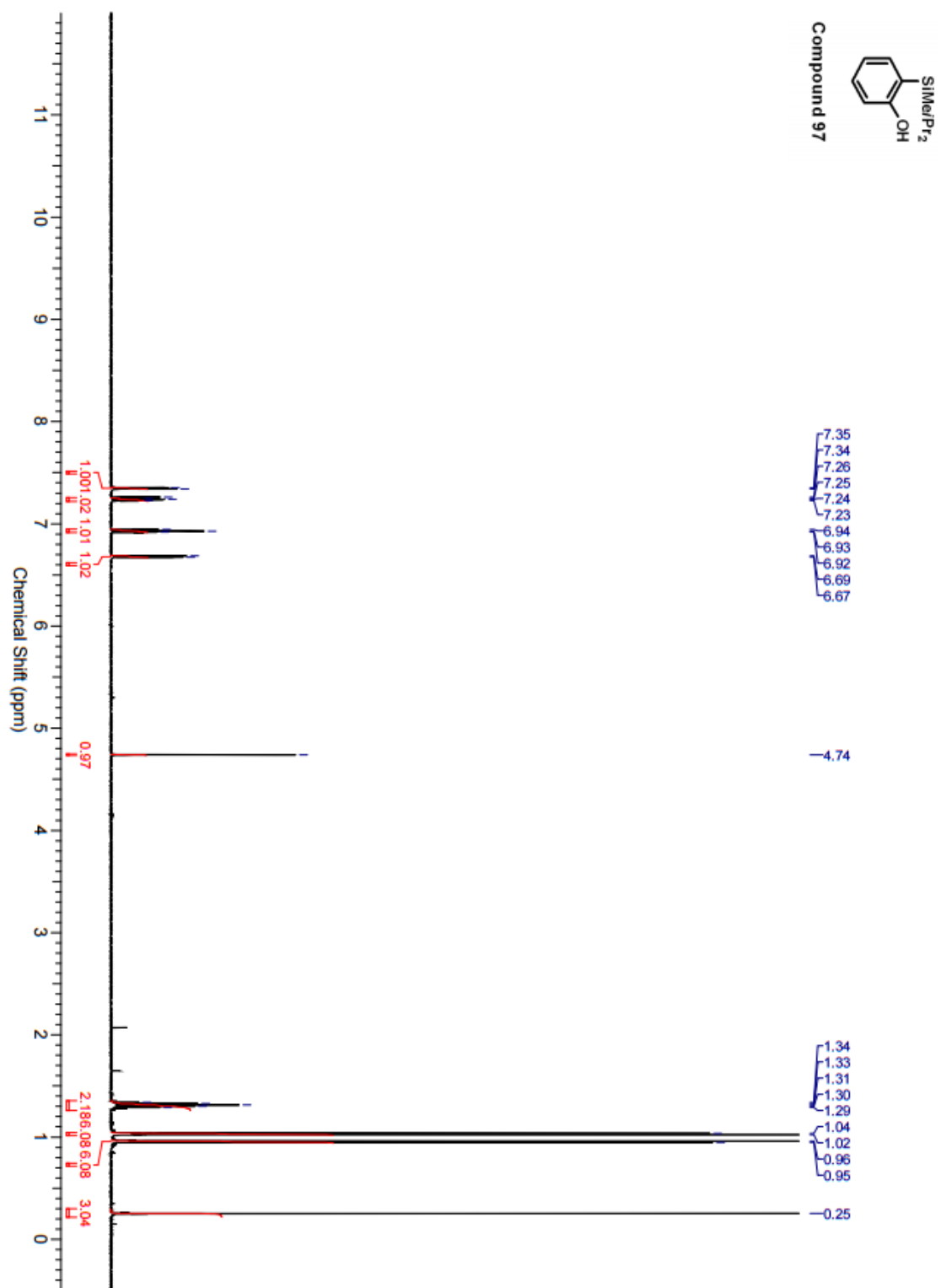
$^1\text{H}$  NMR for **97**

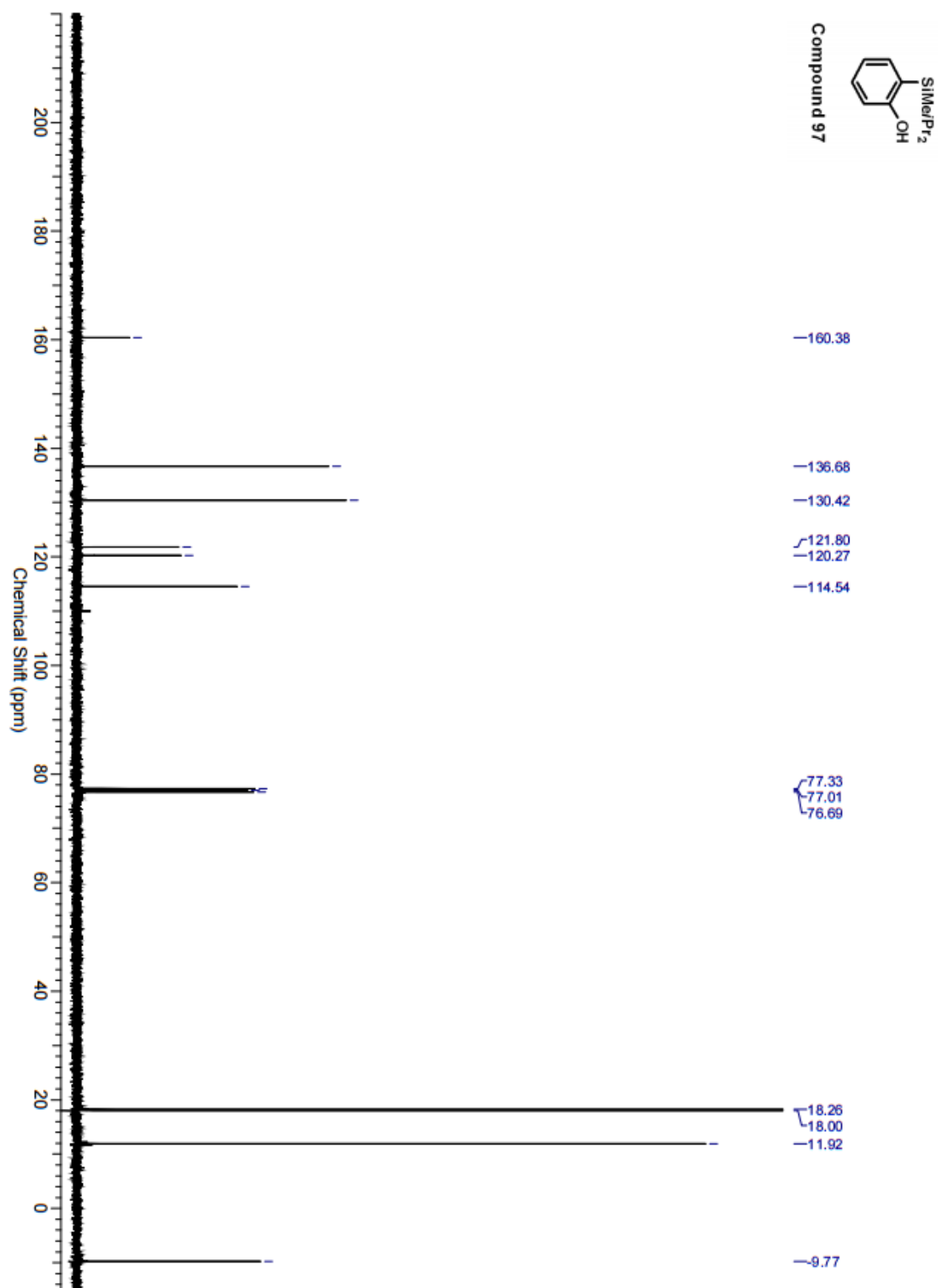
$^{13}\text{C}$  NMR for **97**

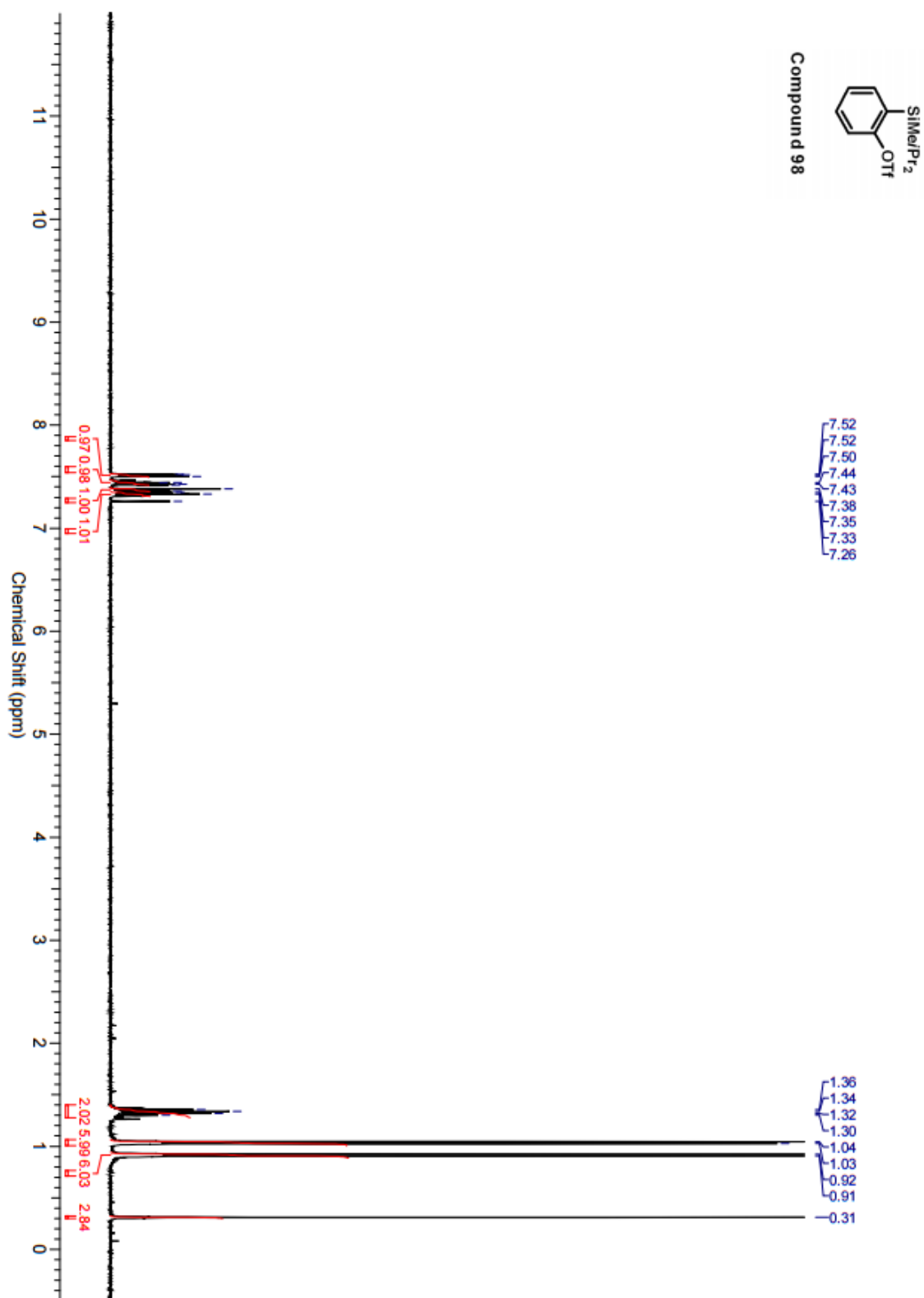

$^1\text{H}$  NMR for **98**

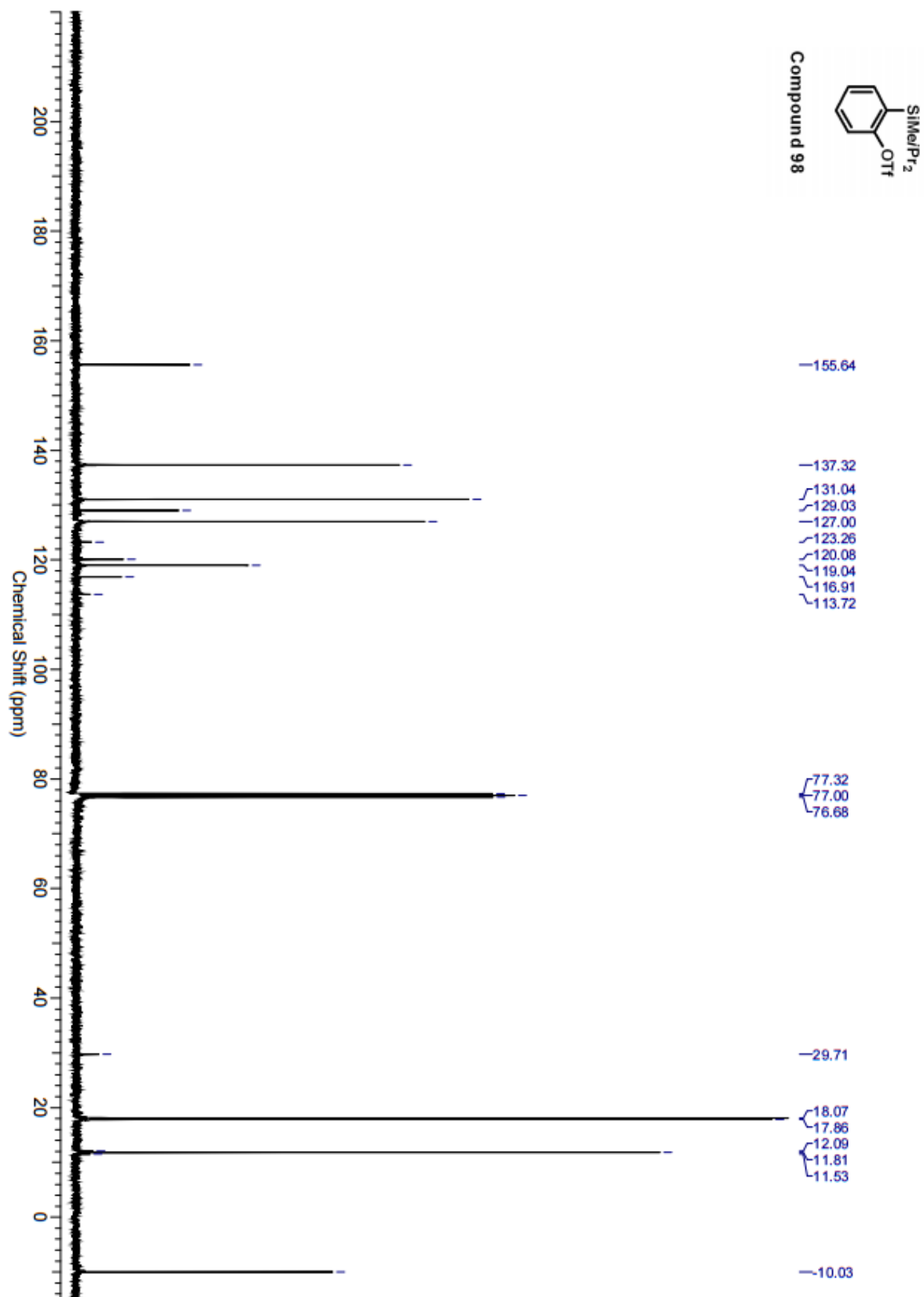
$^{13}\text{C}$  NMR for **98**

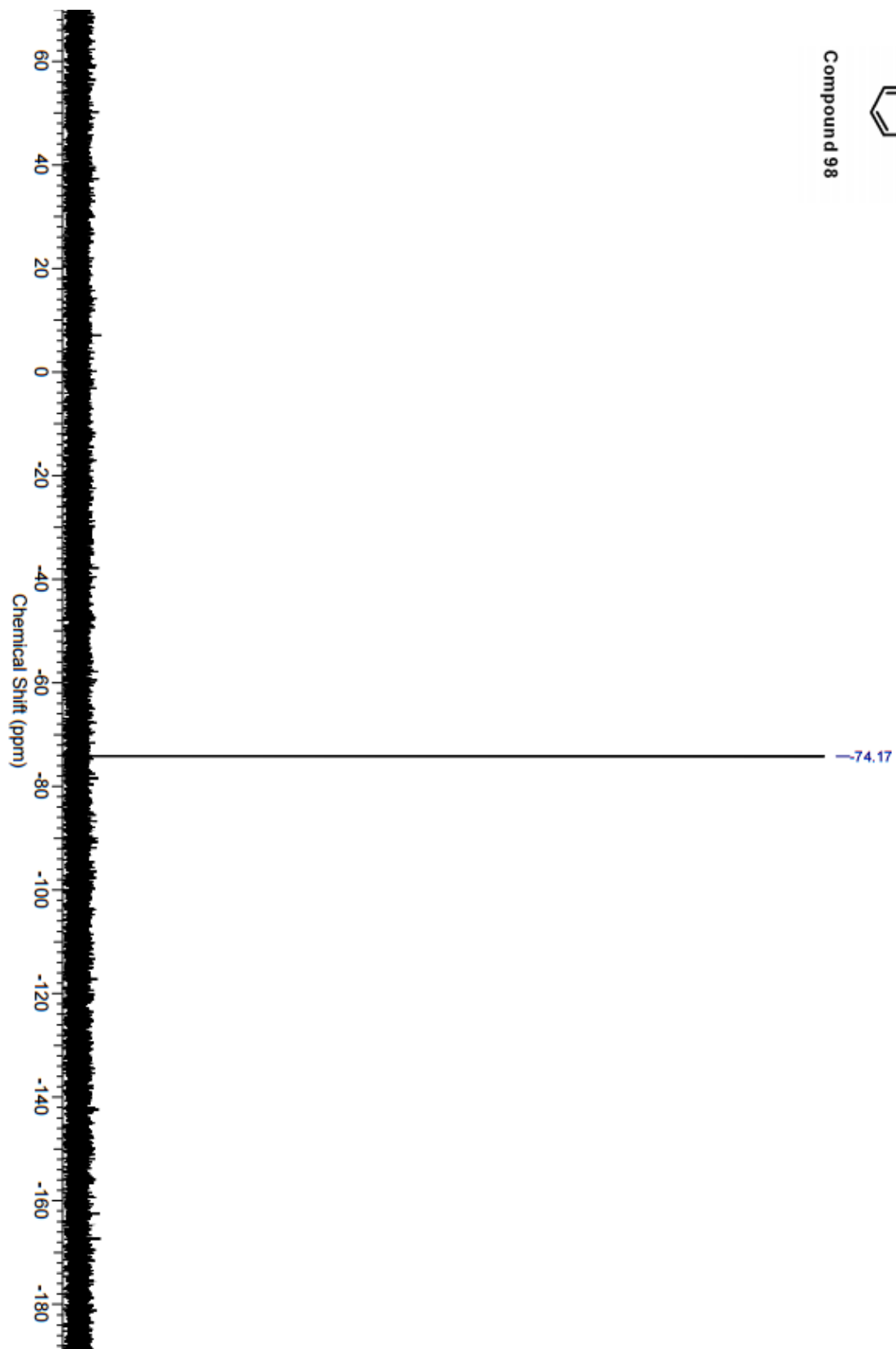
$^{19}\text{F}$  NMR for **98**

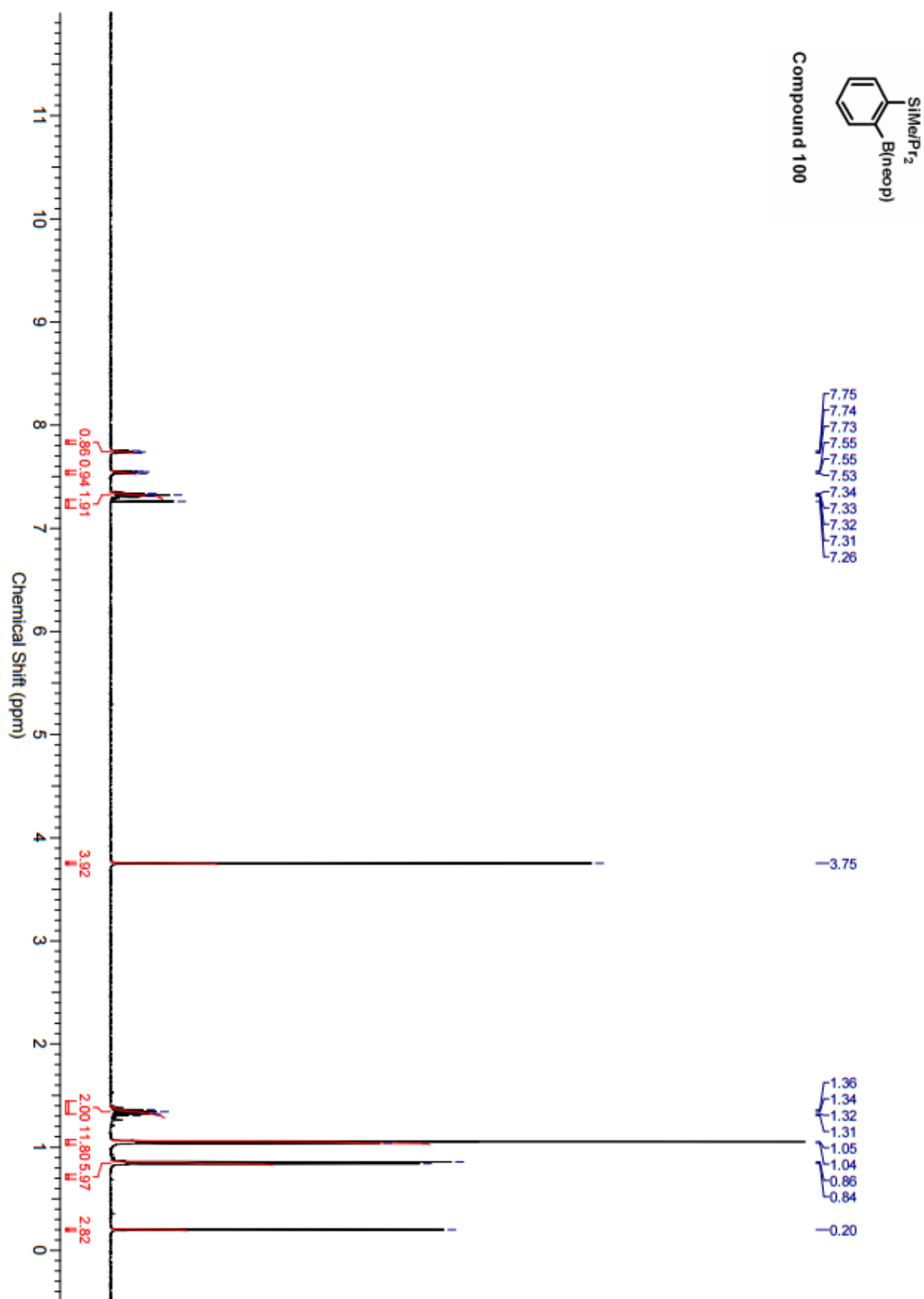
$^1\text{H}$  NMR for **100**

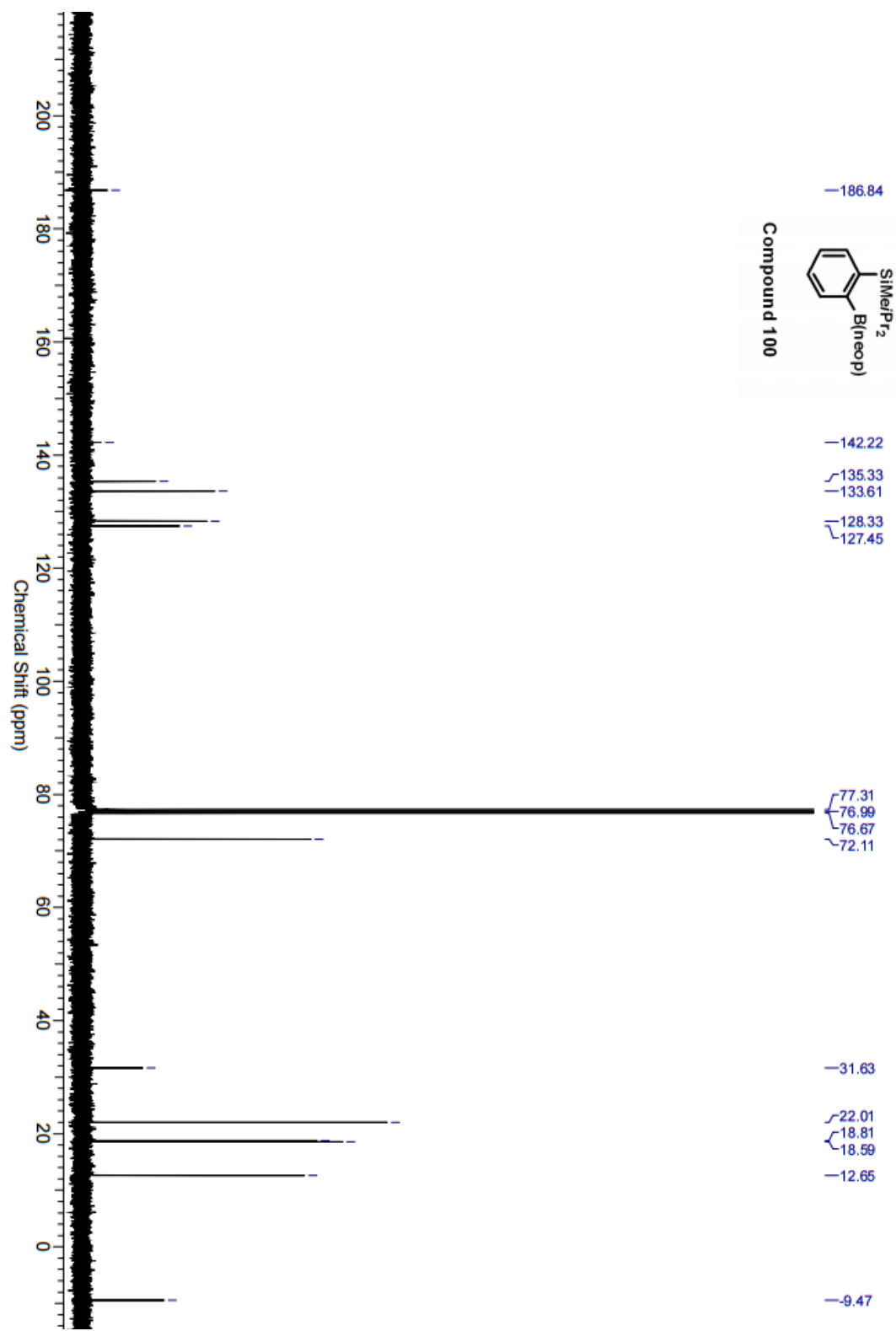
$^{13}\text{C}$  NMR for **100**

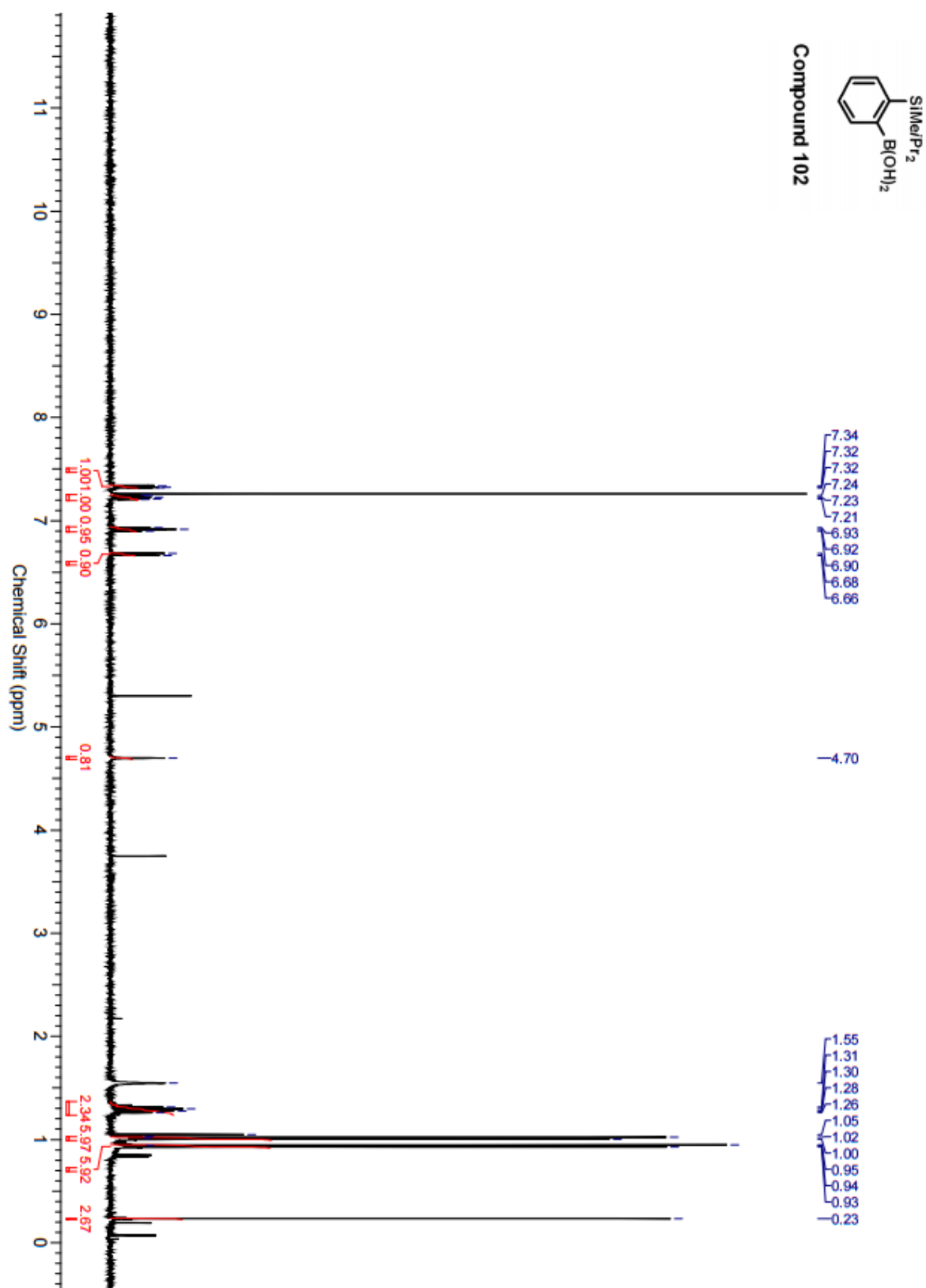
$^1\text{H}$  NMR for **102**

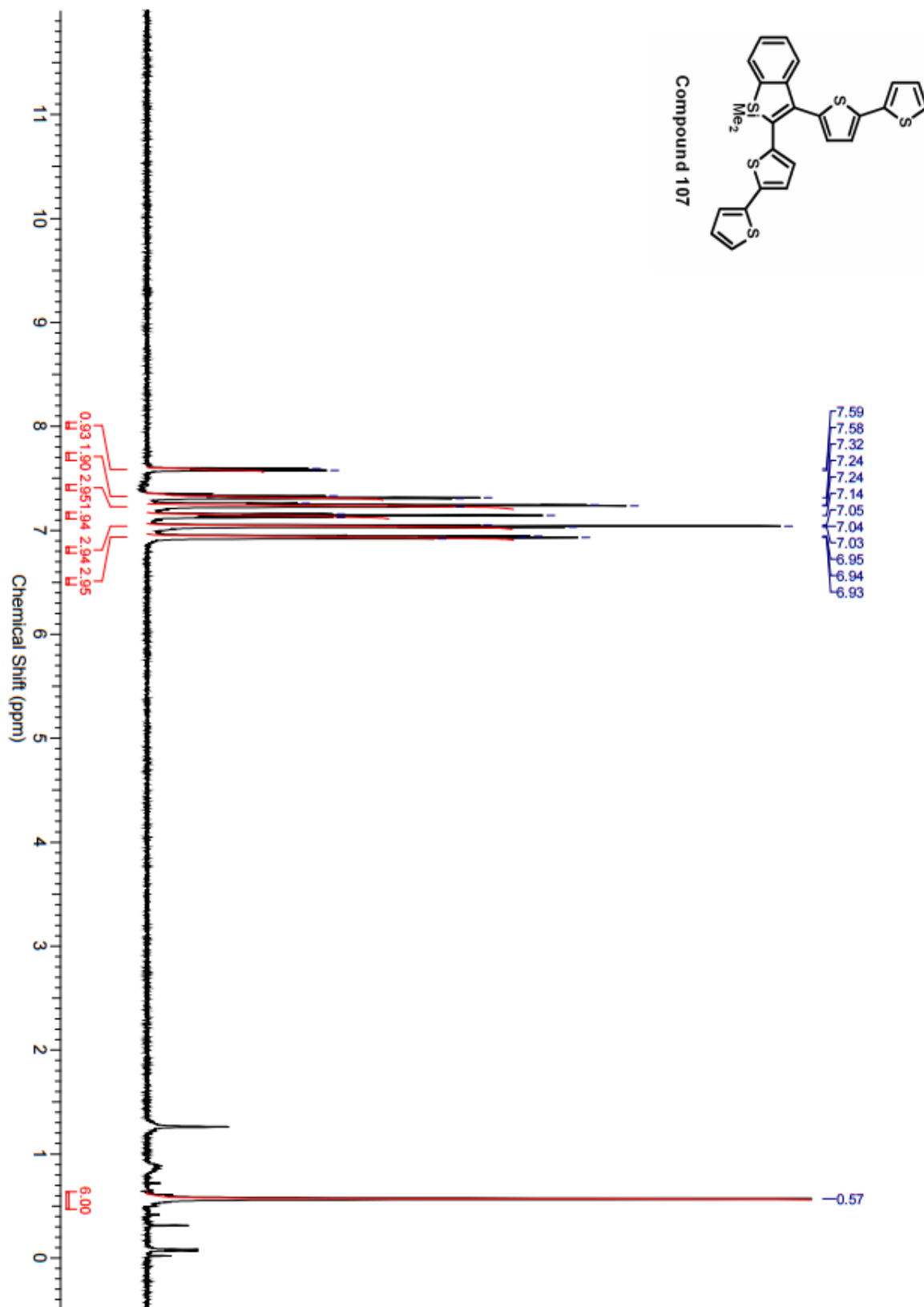
$^1\text{H}$  NMR for **107**

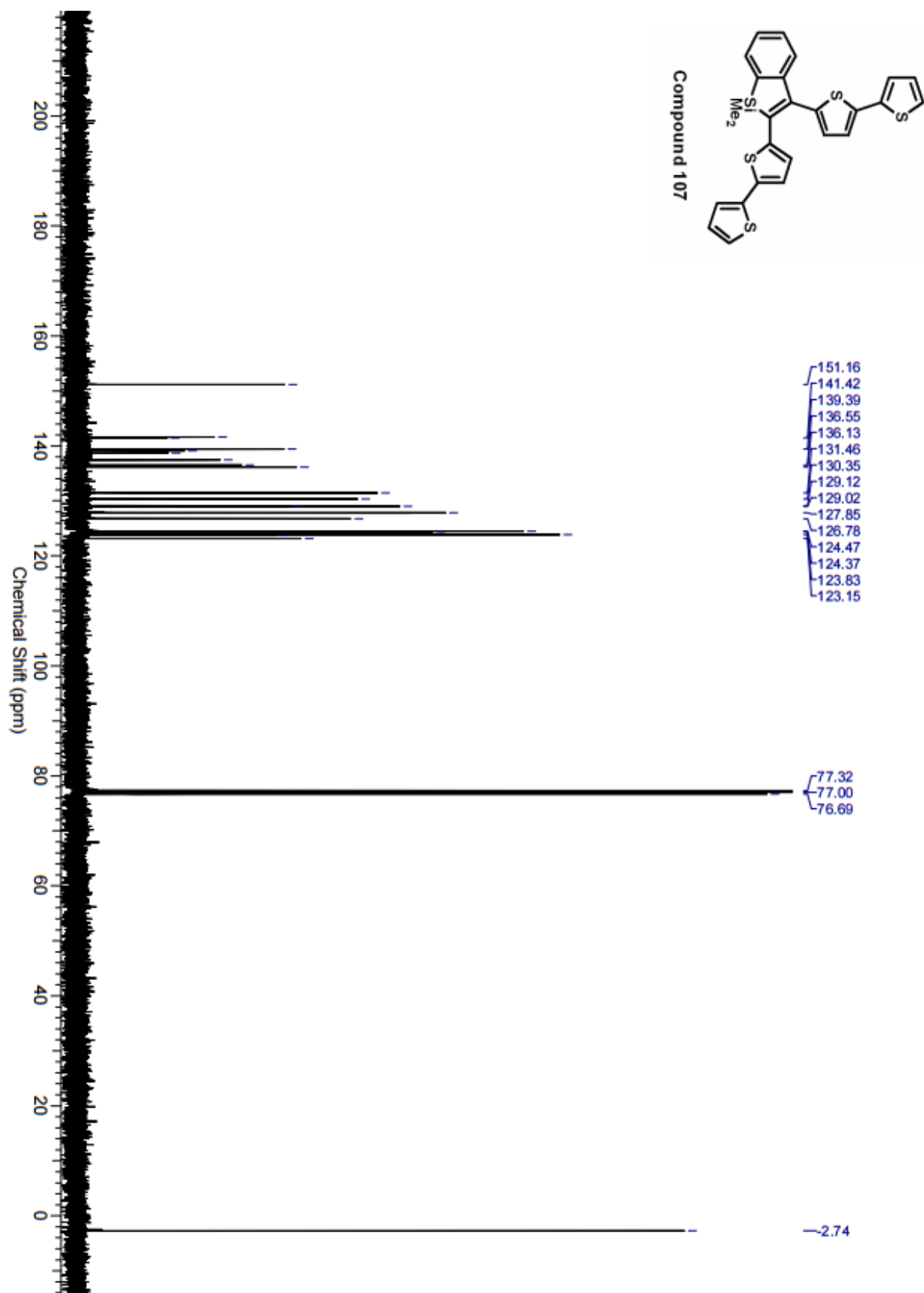
$^{13}\text{C}$  NMR for **107**

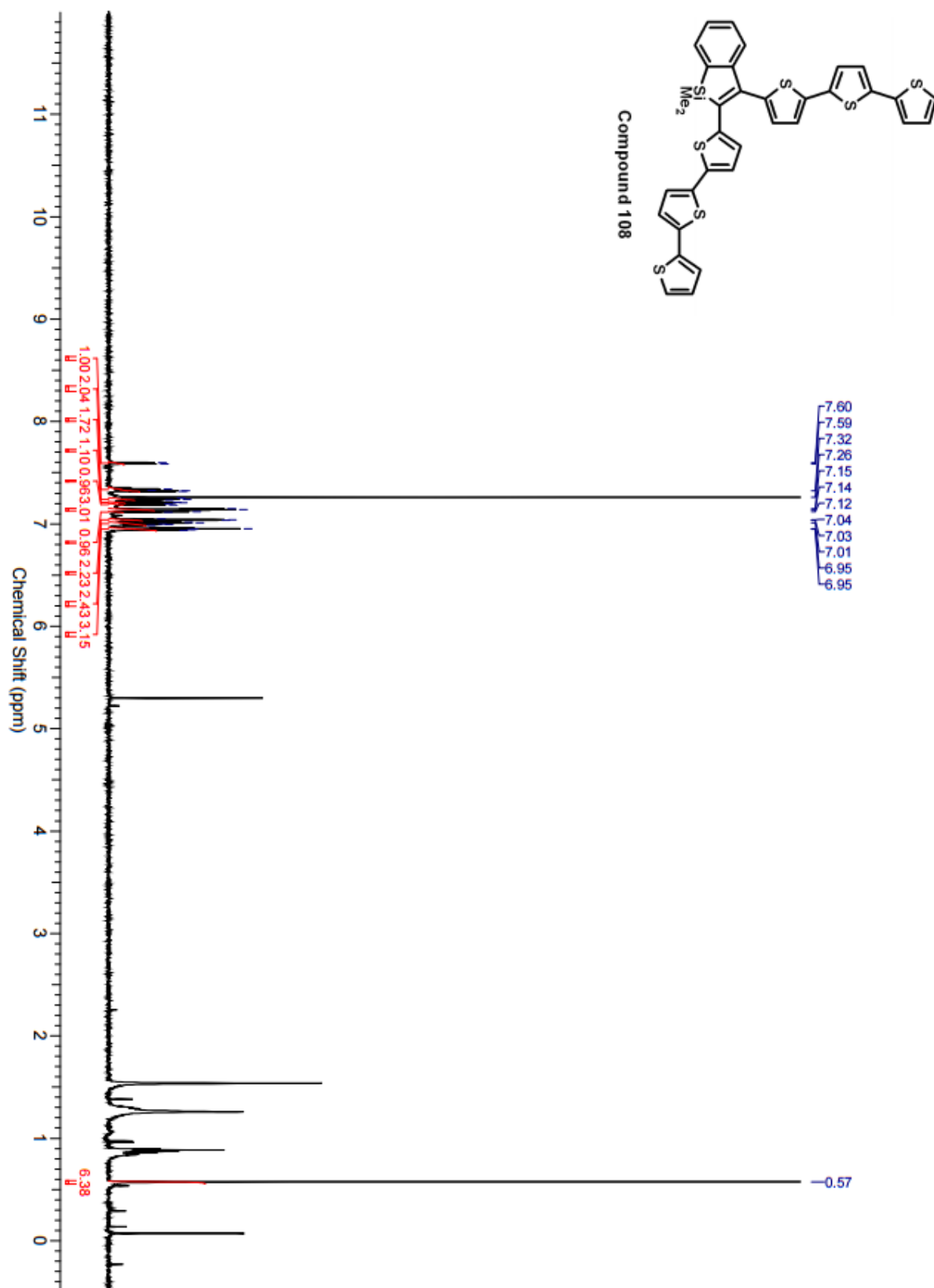

$^1\text{H}$  NMR for **108**

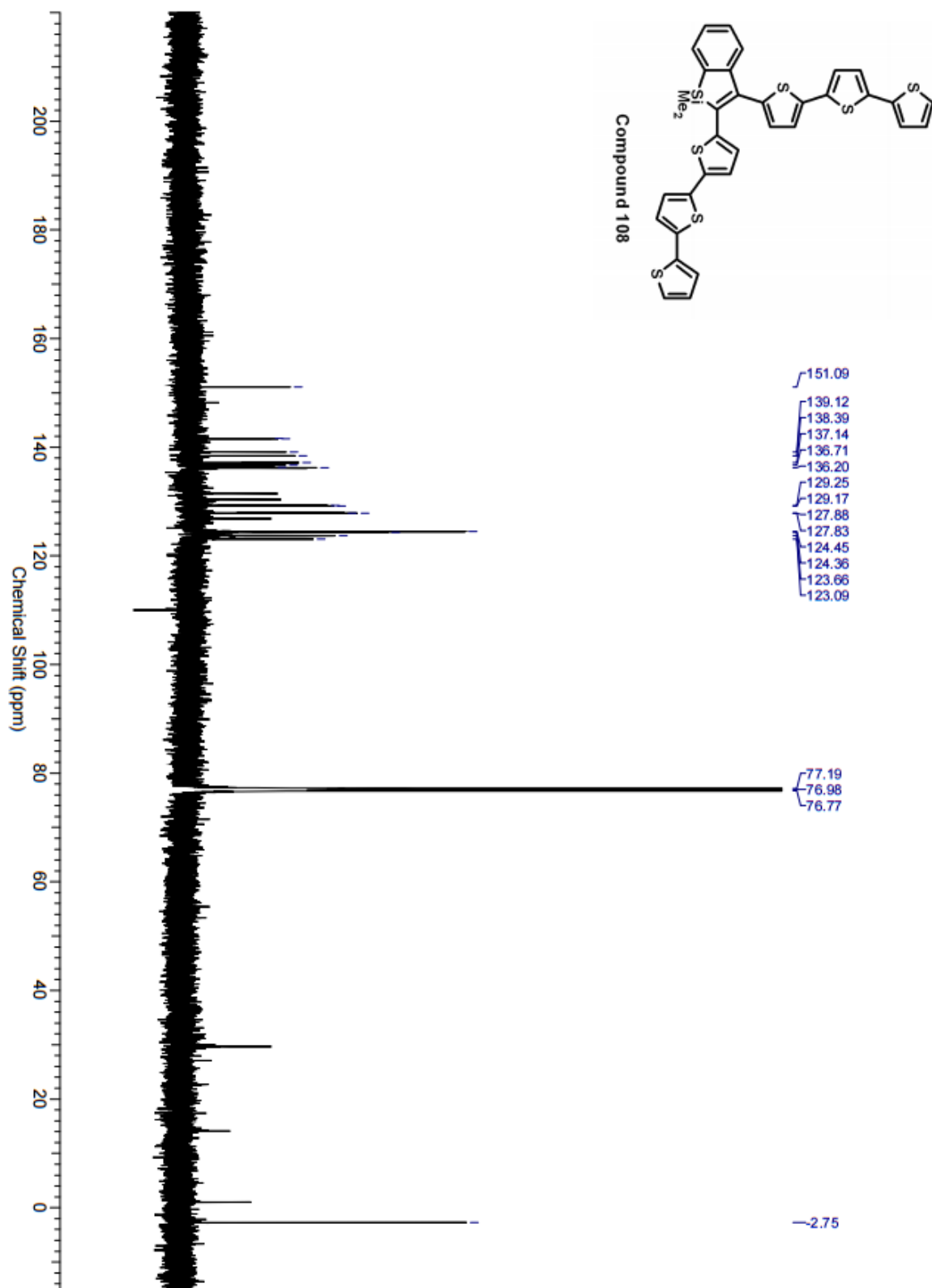
$^{13}\text{C}$  NMR for 108

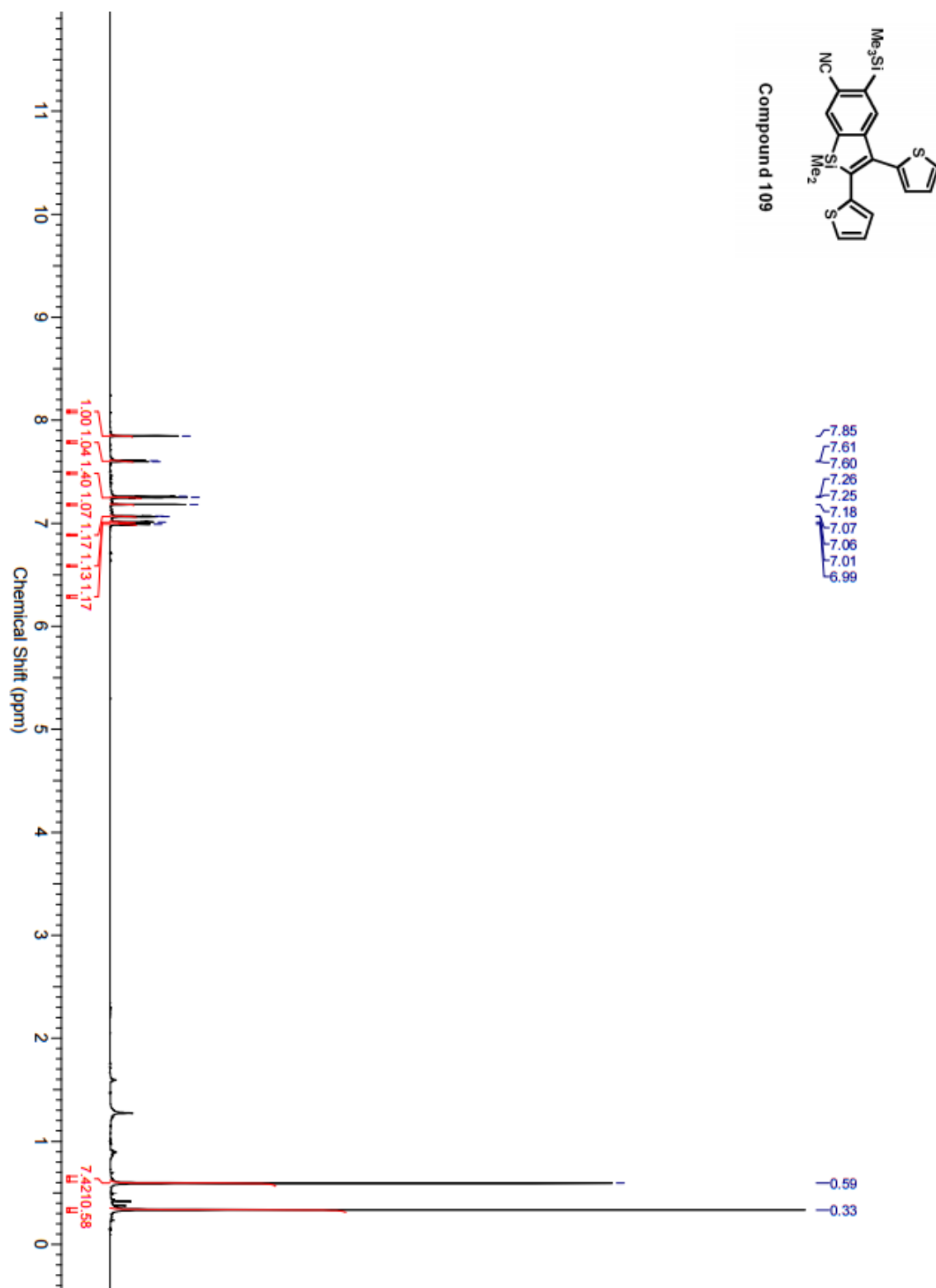
$^1\text{H}$  NMR for **109**

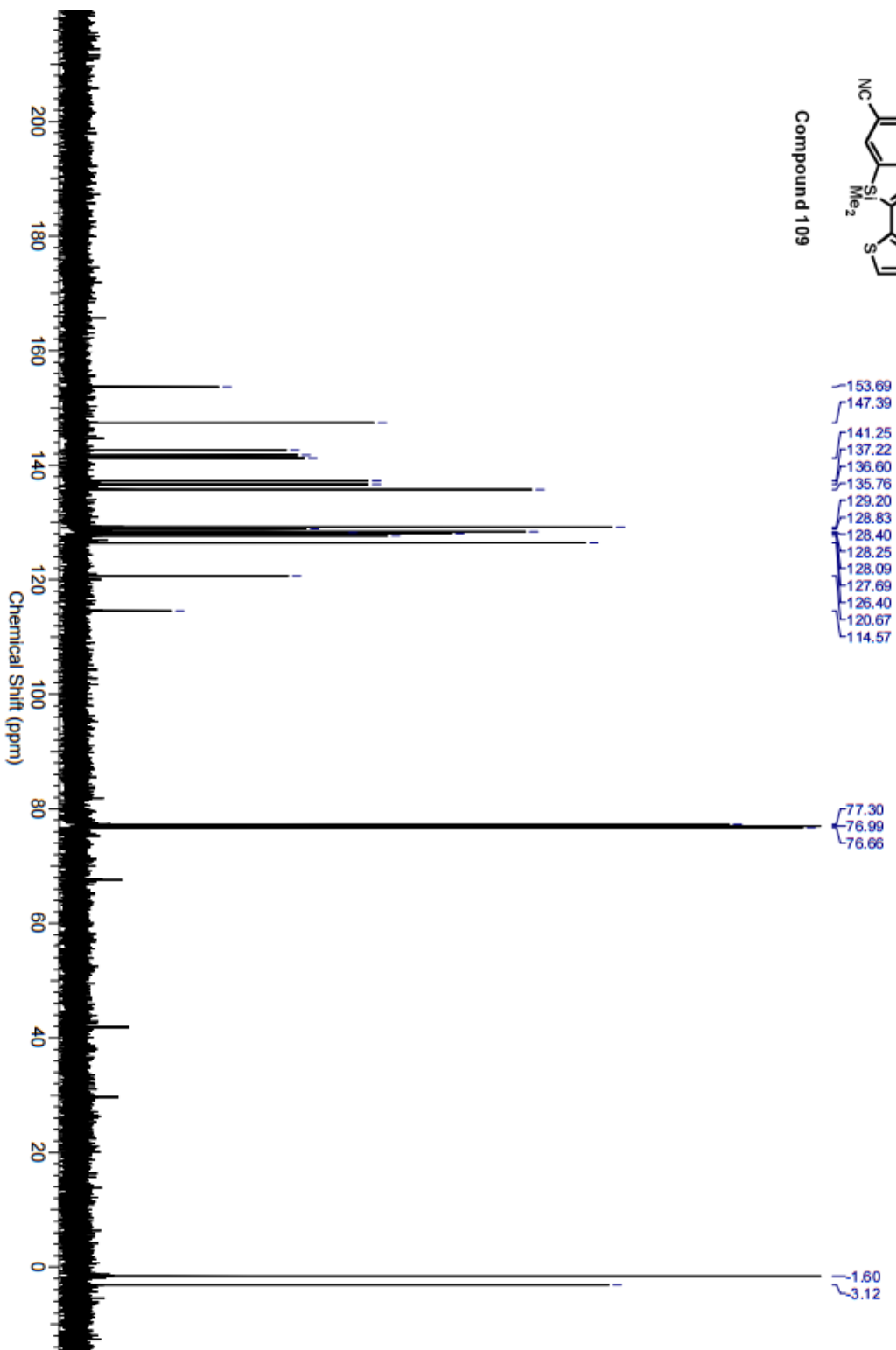
$^{13}\text{C}$  NMR for **109**

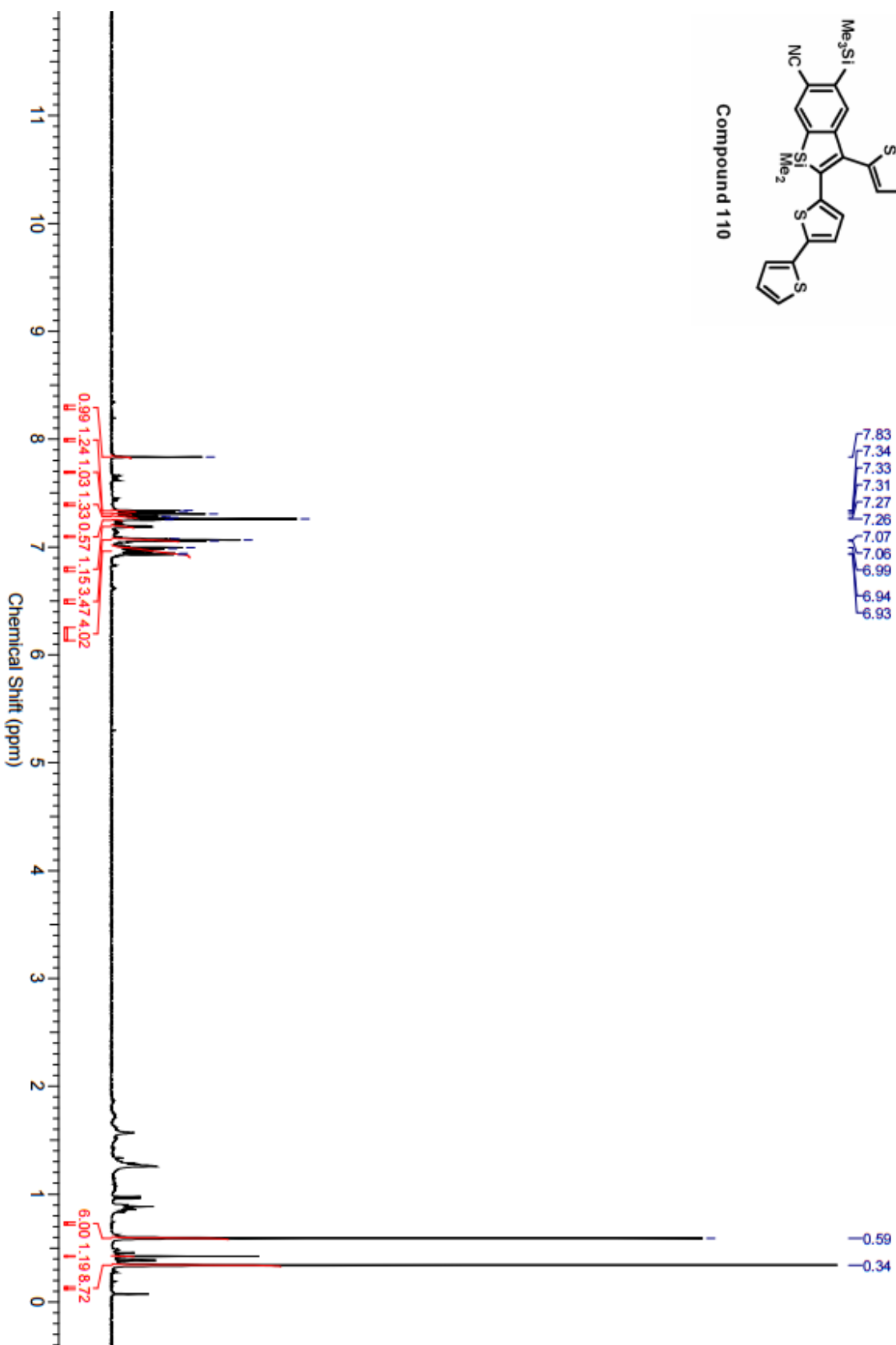
$^1\text{H}$  NMR for **110**

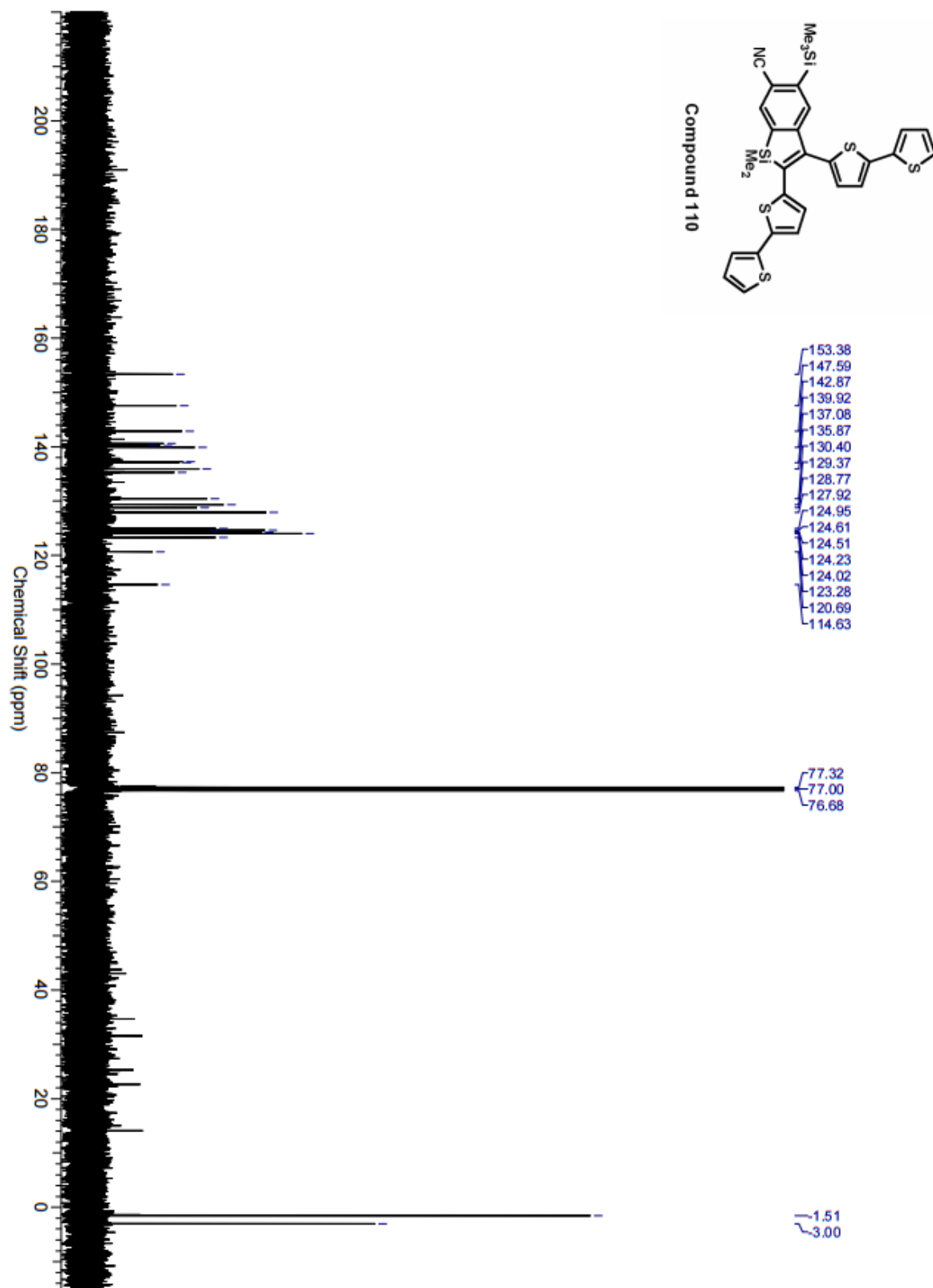
$^{13}\text{C}$  NMR for **110**

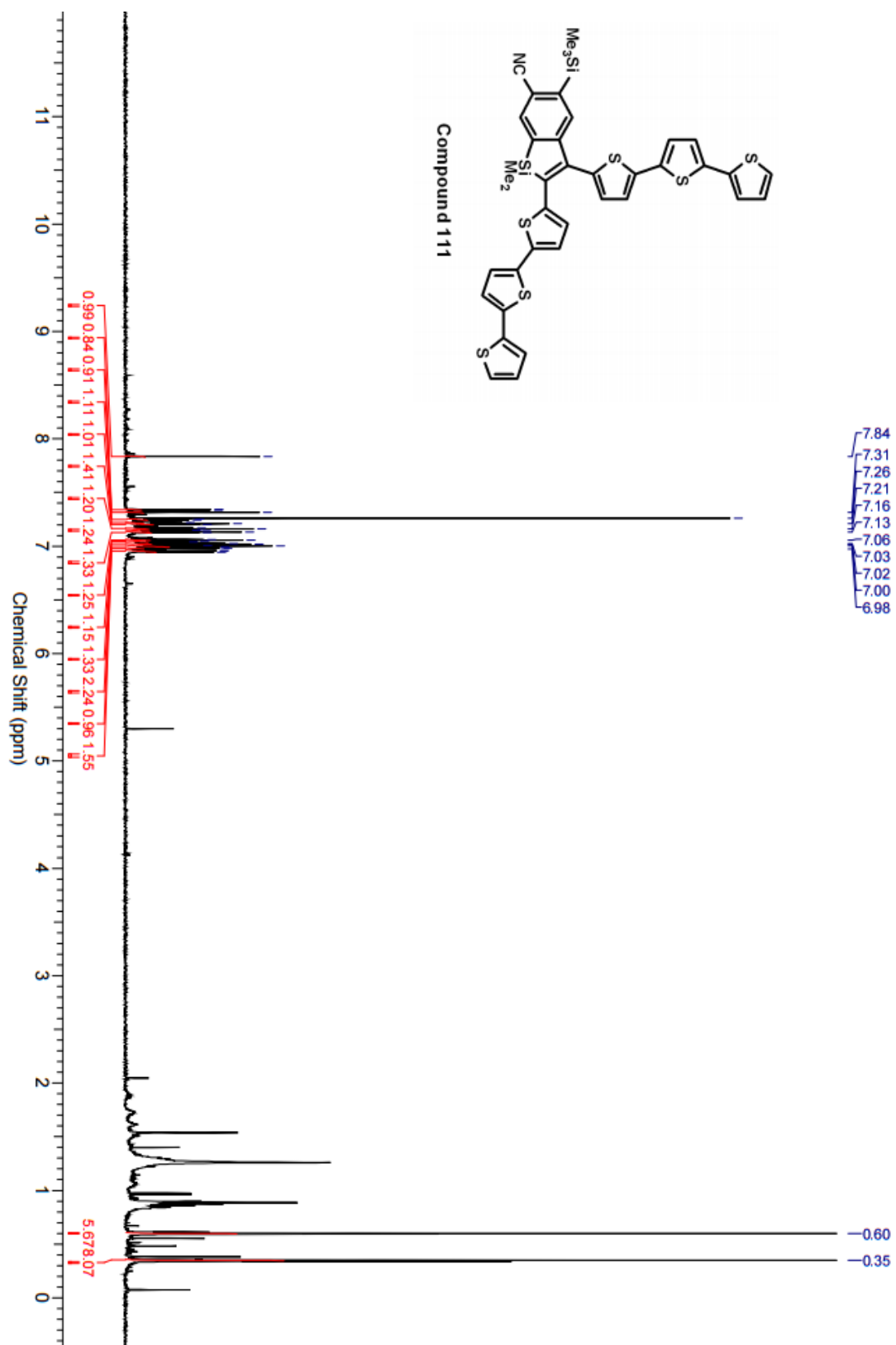
$^1\text{H}$  NMR for **111**

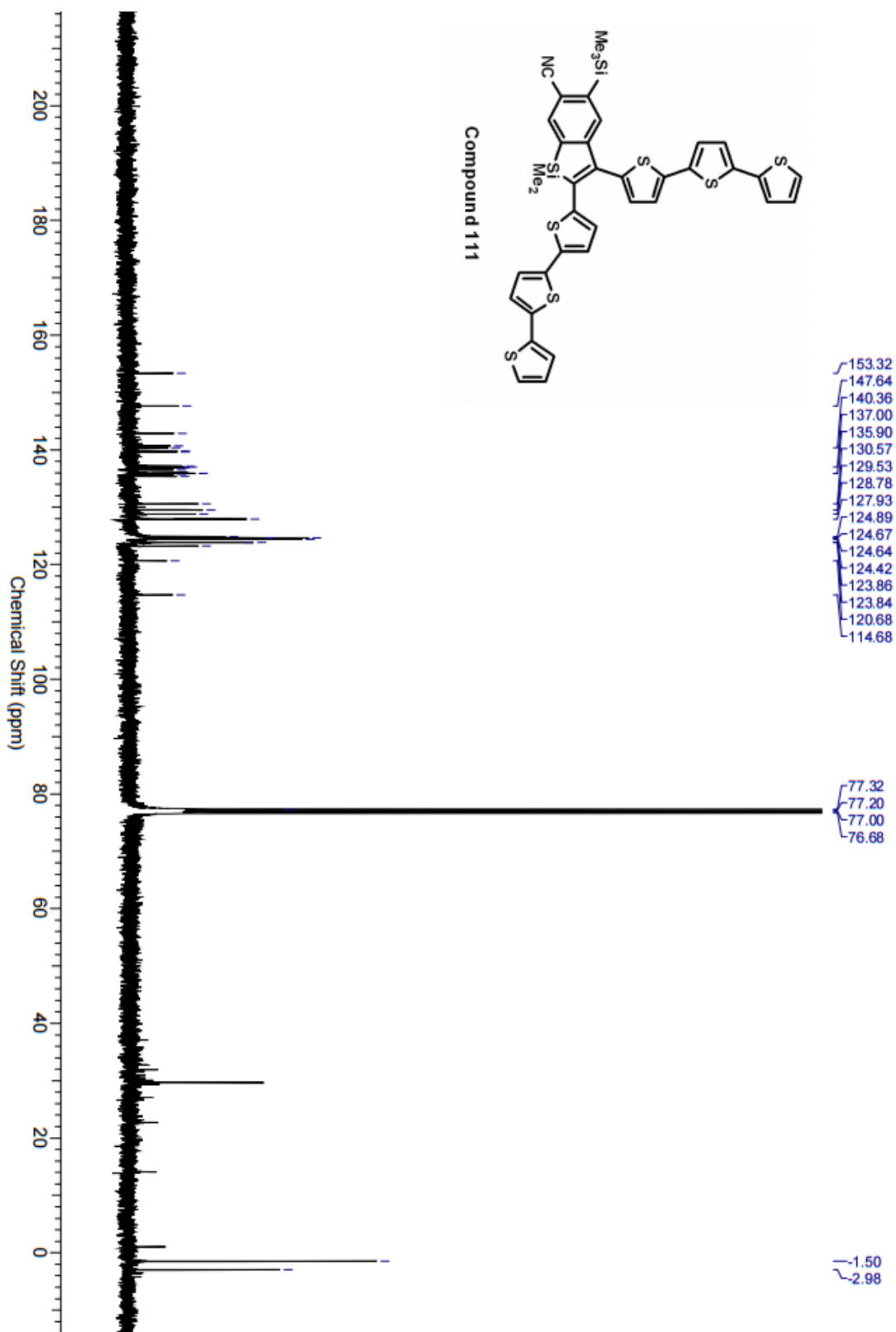
$^{13}\text{C}$  NMR for 111

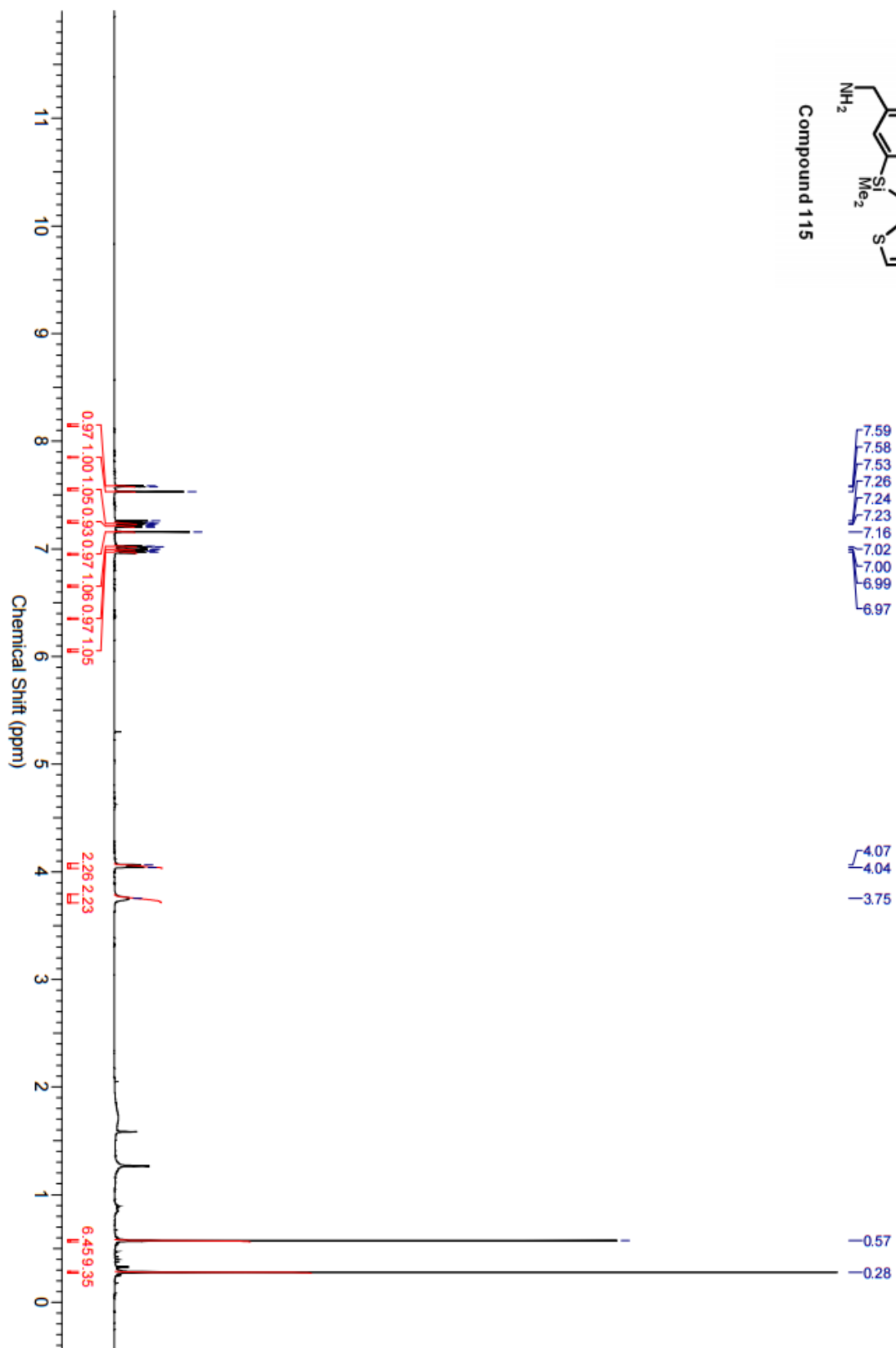

$^1\text{H}$  NMR for **115**

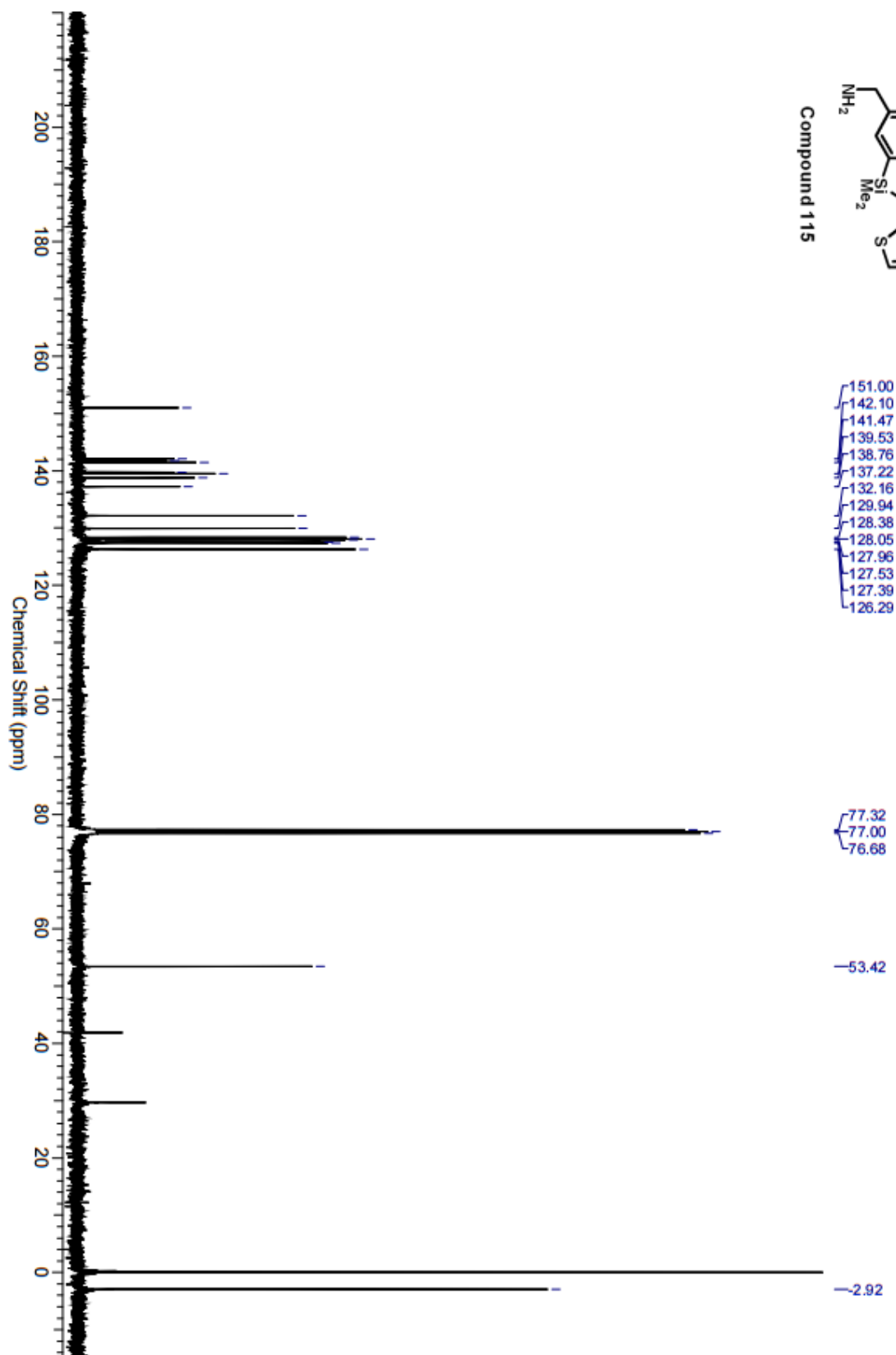
$^{13}\text{C}$  NMR for 115

---

## Curriculum Vitae

Tyler Day

### Education

**The University of Western Ontario** (2013-2016) - M.Sc. in Chemistry

Supervisor: Dr. Brian Pagenkopf

**The University of Western Ontario** (2009-2013) – B.Sc. (Chemistry)

Dissertation: Dipolar Cycloadditions of Donor Acceptor Cyclopropanes with Electron Deficient Nitriles

Supervisor: Dr. Brian Pagenkopf

### Relevant Experience

**Graduate Researcher** - The University of Western Ontario (2013-2016)

**Teaching Assistant** - The University of Western Ontario (2013-2015)

**Undergraduate Thesis Student** – The University of Western Ontario (2012-2013)