Electronic Thesis and Dissertation Repository

9-9-2015 12:00 AM

Characterizing the C-terminal Region of Human Adenovirus E1A: An Undiscovered Country

Michael J. Cohen
The University of Western Ontario

Supervisor
Dr. Joe Mymryk
The University of Western Ontario

Graduate Program in Microbiology and Immunology
A thesis submitted in partial fulfillment of the requirements for the degree in Doctor of
Philosophy
© Michael J. Cohen 2015

Follow this and additional works at: <https://ir.lib.uwo.ca/etd>



Part of the [Cancer Biology Commons](#), [Cell Biology Commons](#), [Molecular Biology Commons](#), and the
[Virology Commons](#)

Recommended Citation

Cohen, Michael J., "Characterizing the C-terminal Region of Human Adenovirus E1A: An Undiscovered Country" (2015). *Electronic Thesis and Dissertation Repository*. 3240.
<https://ir.lib.uwo.ca/etd/3240>

This Dissertation/Thesis is brought to you for free and open access by Scholarship@Western. It has been accepted for inclusion in Electronic Thesis and Dissertation Repository by an authorized administrator of Scholarship@Western. For more information, please contact wlsadmin@uwo.ca.

CHARACTERIZING THE C-TERMINAL REGION OF HUMAN ADENOVIRUS
E1A: AN UNDISCOVERED COUNTRY
(Thesis format: Integrated Article)

by

Michael Jason Cohen

Graduate Program in Microbiology and Immunology

A thesis submitted in partial fulfillment
of the requirements for the degree of
Doctor of Philosophy

The School of Graduate and Postdoctoral Studies
The University of Western Ontario
London, Ontario, Canada

© Michael Jason Cohen 2015

Abstract

Human Adenovirus (HAdV) E1A is the first protein expressed during viral infection. The primary function of E1A is to reprogram the cell for viral replication, but it is additionally capable of transforming primary rodent cells in co-operation with other oncogenes such as HAdV E1B. Despite extensive study, little is known about the function and cellular targets of the C-terminal region of E1A. Importantly, this region is required for the transforming ability of E1A with E1B, but can also suppress transformation with Ras. Previous studies showed that interaction with the C-terminal Binding Protein (CtBP) plays a role in both functions described above. However, other factors must be necessary, as there are mutants of E1A that retain CtBP binding but fail to contribute to either effect. Given the recent identification of new targets of this region of E1A, including FOXK1/2, DYRK1A/1B, and HAN11, I sought to re-evaluate and further characterize the mechanism by which the C-terminus of E1A carries out its functions. I performed an extensive and systematic mutational analysis of the C-terminus of E1A as a means of identifying residues specifically required for binding each cellular target. We then tested our panel of mutants for their ability to transform primary baby rat kidney cells in cooperation with E1B or Ras. Contrary to the current understanding of how the C-terminus of E1A performs its functions, my findings indicate that while CtBP binding is required for transformation with E1B, it is not necessary for the suppression of transformation with Ras. This suggests that other targets in this region play critical roles in this activity. I also discovered that E1A requires a second patch of basic residues upstream of the canonical nuclear localization sequence (NLS) for nuclear localization. Thus, the previously described monopartite NLS located at the C-terminus of E1A is actually a bipartite signal, which had been misidentified. Finally, I also began investigating the global changes in gene expression mediated by the C-terminal targets of E1A during infection using next-generation RNAseq. These studies have expanded on our understanding of the mechanisms by which E1A reprograms the infected cell to induce oncogenic transformation.

Keywords

Human adenovirus, early region 1A, E1A, DYRK1A/B, CtBP1/2, FOXK1/2, importin- α , oncogenic transformation, protein-protein interactions

Co-Authorship Statement

Chapter 2 of this thesis was published in the Journal of Virology, 2013 Sep;87(18):10348-55. I was involved in performing all of the experiments with the exception of the transformation assays in Figures 2.8. Figure 2.8A was conducted by Dr. Andrew Turnell, and Figure 2.8B was conducted by Dr. Biljana Todorovic and Paola Massimi in the laboratory of Dr. Lawrence banks.

Chapter 3 of this thesis was published in Virology, 2014 Nov;468-470:238-43. I was involved in performing all of the experiments.

Chapter 4 of this thesis contains unpublished data. I was involved in performing all of the experiments with help from Dr. Greg Fonseca on the HOMER bioinformatics software.

Acknowledgments

First and foremost, I would like to thank my supervisor and mentor Dr. Joe Mymryk. Your guidance, scientific input, and excellent training throughout my graduate studies have been an invaluable experience that has motivated me to pursue a career in science. Your passion for science and achievements throughout your career are truly an inspiration and you have played an instrumental role in both where I am today and where I will go in the future. It has been an absolute joy, honour, and privilege to have had the opportunity to work with you.

The past and present lab members of “Team Mymryk” helped make my lab experience meaningful and exciting through your positive attitudes, helpful advice, and constant humour. You have all made this long journey an enjoyable one and I will always cherish the friendships and memories we have shared. I would also like to thank the members of my advisory committee, Drs. Greg Dekaban and Rod DeKoter for the time and effort you have invested in helping me with my project, as well as the other members of the Department of Microbiology and Immunology for being such wonderful colleagues.

Thanks to my parents, Ron and Louise, and my sister, Amanda, for your continual love and encouragement throughout all of my endeavors. Of course this extends to the rest of my family and close friends. I owe much of my accomplishments to your love and support.

Finally I would like to thank my wife Melissa for your constant love and kindness, for always believing in me, and for keeping my spirits high through all the ups and downs of grad school. I could not have done this without you in my life, and I dedicate this thesis to you.

Table of Contents

Abstract.....	ii
Co-Authorship Statement.....	iii
Acknowledgments.....	iv
Table of Contents.....	v
List of Tables.....	x
List of Figures.....	xi
List of Abbreviations.....	xiii
Chapter 1.....	1
1 Introduction.....	1
1.1 General Introduction.....	1
1.2 Adenovirus.....	3
1.2.1 Physical properties of adenoviruses.....	3
1.2.2 The genes and life cycle of adenoviruses.....	5
1.3 Human adenovirus early region 1A (E1A).....	8
1.3.1 The adenovirus E1A gene, transcripts, and protein products.....	8
1.3.2 E1A is an unstructured viral hub protein which contains many short linear interaction motifs.....	9
1.3.3 Depending on the context, E1A can act as an oncoprotein or tumour suppressor.....	10
1.3.4 The four regions of E1A.....	13
1.4 The C-terminus of E1A.....	18
1.4.1 The organization of the C-terminus of E1A.....	18
1.4.2 Protein interactions mediated by the C-terminus of E1A.....	19
1.4.3 Immortalization and transformation with E1B.....	22

1.4.4	Suppression of transformation and tumourigenesis with activated Ras ...	24
1.5	Thesis overview and rationale	24
1.5.1	Chapter 2: Dissection of the C-terminal region of E1A re-defines the roles of CtBP and other cellular targets in oncogenic transformation	25
1.5.2	Chapter 3: Functional analysis of the C-terminal region of human adenovirus E1A reveals a misidentified nuclear localization signal	26
1.5.3	Chapter 4: Investigating the functional mechanism by which the cellular targets of the C-terminal region of E1A modulate E1A-dependent transformation.....	26
1.6	References.....	27
Chapter 2	43
2	Dissection of the C-terminal region of E1A re-defines the roles of CtBP and other cellular targets in oncogenic transformation	43
2.1	Introduction.....	43
2.2	Materials and Methods.....	46
2.2.1	Cell lines, cell culture and transfections	46
2.2.2	Plasmids	47
2.2.3	Western blotting and co-immunoprecipitation	47
2.2.4	Immunofluorescence microscopy	47
2.2.5	Transformation Assays	49
2.2.6	Statistical analysis.....	49
2.3	Results.....	49
2.3.1	The E1A proteins from different HAdV species differ in their interaction with known targets of the C-terminus of HAdV5 E1A	49
2.3.2	Detailed mapping of the protein interactions mediated by the C-terminus of HAdV5 E1A	50
2.3.3	Efficient nuclear localization of HAdV5 E1A requires a region distinct from the canonical NLS	53

2.3.4	E1A-mediated transformation of rodent cells in cooperation with E1B-55K is enhanced by the interaction with DYRK1A and HAN11 and requires CtBP binding.....	56
2.3.5	E1A's interaction with other targets, but not with CtBP, is required for suppression of Ras mediated transformation of rodent cells	59
2.4	Discussion.....	61
2.5	References.....	68
Chapter 3.....		72
3	Functional analysis of the C-terminal region of human adenovirus E1A reveals a misidentified nuclear localization signal.....	72
3.1	Introduction.....	72
3.2	Materials and Methods.....	75
3.2.1	Cell lines, cell culture, and transfections	75
3.2.2	Plasmids	75
3.2.3	Western blotting and co-immunoprecipitation	75
3.2.4	Immunofluorescence microscopy and image analysis.....	76
3.3	Results.....	76
3.3.1	The C-terminal E1A NLS requires both the major and minor binding groove of Qip1	76
3.3.2	The C-terminal E1A bipartite NLS is comprised of residues 258-289.....	77
3.3.3	The C-terminal bipartite NLS of E1A is sufficient for nuclear localization.....	80
3.4	Discussion.....	83
3.5	References.....	88
Chapter 4.....		92
4	Investigating the functional mechanism by which the cellular targets of the C-terminal region of E1A modulate E1A-dependent transformation.....	92
4.1	Introduction.....	92

4.2	Materials and Methods.....	95
4.2.1	Cells and viruses	95
4.2.2	Cell infections	95
4.2.3	Western blotting and co-immunoprecipitations.....	95
4.2.4	mRNA isolation and PCR.....	96
4.2.5	High-throughput sequencing.....	96
4.2.6	Data analysis	96
4.2.7	Confocal immunofluorescence microscopy and TUNEL assay	97
4.3	Results.....	97
4.3.1	Generation of two novel HAdV mutants to disrupt the DYRK1A/HAN11 and CtBP interactions	97
4.3.2	Cellular mRNA expression alterations mediated by the C-terminal interactions of E1A	98
4.3.3	Differential expression profile of wildtype HAdV vs C-terminal mutants.....	100
4.3.4	The HAdV R262/263E mutant induces apoptosis.....	104
4.4	Discussion.....	106
4.5	References.....	113
Chapter 5.....		116
5	General Discussion and Future Directions.....	116
5.1	Thesis Summary.....	116
5.2	Redefining the models of E1A-mediated oncogenic transformation by the C- terminus of E1A.....	117
5.3	Altering our understanding of one of the oldest documented NLSs.....	119
5.4	The potential role of DYRK1A, HAN11, and CtBP in E1A-mediated oncogenic transformation with E1B	120
5.5	The potential role of DYRK1A, HAN11, and FOXK1 in E1A-mediated suppression of transformation with Ras.....	122

5.6 Concluding Remarks.....	124
5.7 References.....	125
Curriculum Vitae	128

List of Tables

Table 2-1 List of Primers used in PCR for plasmid construction	48
Table 4-1 List of significantly impacted KEGG pathway and GO terms based on DE genes between cells infected with wildtype or mutant HAdVs	105

List of Figures

Figure 1.1 A schematic representation of the HAdV-5 double stranded DNA genome.....	2
Figure 1.2 Classification of HAdV Species	4
Figure 1.3 E1A splice products.....	11
Figure 1.4 Alignment of selected E1A proteins from different HAdV species.....	12
Figure 1.5 The HAdV E1A Interactome.....	15
Figure 1.6 Map of E1A conserved regions and the location of selected linear interaction motifs	16
Figure 1.7 Map of the largest E1A protein and organization of the C-terminus of E1A..	20
Figure 1.8 Protein interaction network of the C-terminal portion of E1A.....	23
Figure 2.1 E1A conserved regions and location of known C-terminal target proteins.....	44
Figure 2.2 Conservation of binding for the C-terminal targets of E1A	51
Figure 2.3 Amino acid sequence alignment of CR4 across HAdV species.....	54
Figure 2.4 Detailed mapping of the protein interactions mediated by the C-terminus of HAdV5 E1A.....	55
Figure 2.5 Subcellular localization of the C-terminal E1A mutants.....	57
Figure 2.6 Analysis of E1A mutants exhibiting a nuclear/cytoplasmic phenotype by confocal microscopy	58
Figure 2.7 E1A mutants exhibiting a nuclear/cytoplasmic phenotype have a deficiency in Qip1 binding	60

Figure 2.8 Ability of C-terminal E1A mutants to oncogenically transform primary rodent cells in cooperation with E1B or activated Ras	62
Figure 3.1 Amino acid sequence alignment of CR4 across HAdV species.....	74
Figure 3.2 The C-terminus of E1A binds importin- α like a bipartite NLS.....	78
Figure 3.3 Detailed mapping of the interaction of the C-terminus of E1A with importin- α	81
Figure 3.4 Nuclear localization of C-terminal truncations of E1A.....	84
Figure 4.1 Proposed model of E1A-mediated oncogenic transformation.....	93
Figure 4.2 Verification of endogenous DYRK1A or CtBP interactions and expression of E1A	99
Figure 4.3 Host cell gene expression regulated by the C-terminal targets of E1A.....	101
Figure 4.4 Differential gene expression between wildtype HAdV and viral mutants unable to interact with FOXK1, DYRK1A/HAN11, or CtBP.....	102
Figure 4.5 Comparisons of DE genes identified for each C-terminal target of E1A.....	107
Figure 4.6 Induction of apoptosis by the R262/263E HAdV mutant	110

List of Abbreviations

Activating protein-2	AP2
Adenovirus death protein	ADP
American Type Culture Collection	ATCC
Anthocyanin 11	AN11
Arginine-glycine-aspartic acid	RGD
Auxiliary Region 1	AR1
Baby rat kidney	BRK
B-cell CLL/lymphoma 2	Bcl2
BCL2-associated X protein	BAX
Bovine serum albumin	BSA
Co-immunoprecipitation	co-IP
Conserved region	CR
Coxsackievirus and adenovirus host receptor	CAR
CREB binding protein	CBP
C-terminal binding protein	CtBP
Cytopathic effect	CPE
Database for Annotation, Visualization, and Integrated Discovery	DAVID
Differentially expressed	DE
DNA double-stranded break responses	DSBR
Double-stranded DNA	dsDNA
DREAM complex	DP, RB, E2F, and MuvB
Dual-specificity tyrosine-regulated kinase	DYRK
Dulbecco's modified Eagle's medium	DMEM

E1A Serine 219	Ser219
Early Region 1A	E1A
Early Region 1B	E1B
Early region 2 early	E2e
Early region 2 late	E2l
Early region 3	E3
Early region 4	E4
Epithelial to mesenchymal transition	EMT
Fetal bovine serum	FBS
Forkead box K	FOXK
Forkhead	FKH
Gene Ontology	GO
General control of amino acid synthesis, yeast, homolog-like 2	GCN5
Glyceraldehyde-3-phosphate dehydrogenase	GAPDH
Green fluorescence protein	GFP
Histone 2B	H2B
Histone acetyltransferase	HAT
Histone h3 lysine 18	H3K18
Hooded lister rat embryo fibroblast	HLREF
Hours post infection	hpi
Human Adenovirus	HAdV
Human E3 ubiquitin-protein ligase Bre1	hBre1
Human embryonic kidney	HEK
Human orthologue of AN11	HAN11

Human papillomavirus	HPV
Immunoprecipitation	IP
Importin- β binding	IBB
Interferon	IFN
Interferon-stimulated gene	ISG
Inverted terminal repeats	ITR
Kilo Dalton	kDa
Kilobase pair	kbp
Kyoto Encyclopedia of Genes and Genomes	KEGG
Major histocompatibility complex I	MHCI
Mechanistic target of rapamycin	mTOR
mediator complex Subunit 23	MED23
Multiplicity of infection	MOI
Nonidet-P40	NP40
Nuclear localization sequence	NLS
Nuclear magnetic resonance	NMR
Nucleoplasmin protein	NP
Open reading frame	ORF
Phosphate-buffered saline	PBS
Phosphatidylinositol 3-kinase	PI3K
Polyvinylidene difluoride	PVDF
Promyelocytic leukemia nuclear body	PML
Protein kinase A	PKA
Protein phosphatase 2	PP2A

Reads per kilobase of transcript per million mapped reads	RPKM
Receptor internalization and degradation complex	RID $\alpha\beta$
Retinoblastoma susceptibility gene product	pRb
RNA sequencing	RNAseq
Short linear interaction motif	SLIM
Small interfering RNA	siRNA
Small ubiquitin-like modifier	SUMO
T-antigen	T-Ag
TATA binding protein	TBP
Terminal deoxynucleotidyl transferase-mediated dUTP nick end labeling	TUNEL
Terminal protein	TP
TNF superfamily, member 6	FAS
TNF-related apoptosis-inducing ligand	TRAIL
Tris-buffered saline	TBS
Tumour necrosis factor	TNF
Ubiquitin conjugase 9	UBC9
U-exon protein	UXP
Viral associated RNA	VARNA
Wild-type	WT
Yet another kinase 1	YAK1
Zinc finger E-box binding homeobox 1	ZEB1
Zinc finger MYND domain-containing protein 11	ZMYND11 *referred to as BS69

Chapter 1

1 Introduction

1.1 General Introduction

Viruses are obligate intracellular organisms and as such, require a healthy, energy producing cell in order to replicate their genomes and persist. This often necessitates the existence of a complex network of interactions between viral and cellular proteins to reorganize the cellular milieu into an environment favorable for the production of viral progeny. Studies of virus-host cell interactions have provided a wealth of knowledge in our understandings of the molecular biology of the cell. Indeed, the study of Human Adenoviruses (HAdVs) is no exception, having played a pivotal role in seminal discoveries on such processes as cell cycle control, transcription, mRNA processing, apoptosis, immunological responses and oncogenic transformation (Berk 2013).

Adenovirus was originally discovered in 1953 (Rowe et al. 1953), when it was isolated from human adenoid tissue, which is how the virus was named. One year later, HAdV was implicated as a causative agent for acute respiratory disorder (Hilleman and Werner 1954). HAdVs are small non-enveloped viruses with a linear double-stranded DNA (dsDNA) genome of approximately 36 kilobase pairs (kbp) in size (Figure 1.1). The adenovirus family now includes more than one hundred viruses infecting a wide range of mammalian, avian, and reptilian species. Specifically for HAdV, there are currently 57 types of HAdV that are sub-divided into 7 species based on a series of biological properties (Figure 1.2). These species are similar at the molecular level, although some have evolved to possess specific tissue tropisms, including the respiratory system, the intestinal digestive system, and the hematopoietic system (Berk 2013).

Nearly 10 years after its initial discovery, interest in the HAdV field was re-ignited when injection of HAdV type 12 into newborn hamsters was shown to induce malignant and aggressive tumours (Trentin et al. 1962). This marked the first documented finding of a human virus causing cancer, albeit in a rodent system. Not all HAdV types are capable of causing cancer in rodents, and this was one of the original properties used to classify

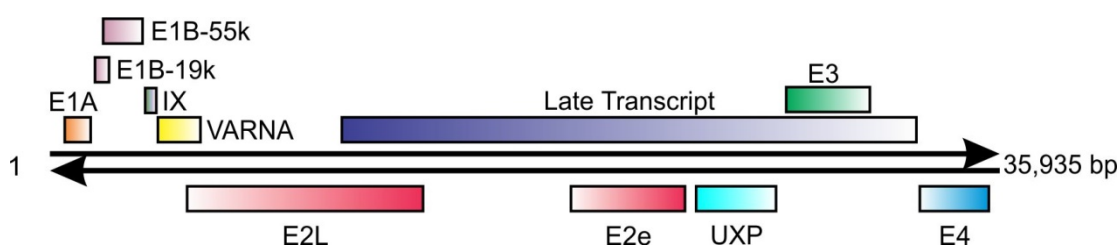

Figure 1.1 A schematic representation of the HAdV-5 double stranded DNA genome

The HAdV-5 genome is composed of ten transcriptional units. Five are expressed early during infection and include E1A, E1B, E2e, E3, and E4. Two transcripts are expressed delayed early: IX and VARNA, and three are expressed late during infection; Late genes, E2L, and UXP.

HAdV members into different species. These differences in tumorigenicity can, in part, be attributed to differences in the ability of HAdV members to evade host immune responses (Gallimore 1972). Importantly, all HAdVs so far tested are capable of transforming rodent cells in culture (McBride and Wiener 1964; Freeman et al. 1967; Berk 2013). Following this discovery, researchers began to elucidate how HAdV is able to reprogram the cell to induce a cancer phenotype. The Early Region 1A (E1A) gene of HAdV has had the largest impact on these findings, and is the primary focus of this thesis.

1.2 Adenovirus

1.2.1 Physical properties of adenoviruses

Adenoviruses are non-enveloped viral particles consisting of a linear dsDNA genome housed in an icosohedral protein shell, or capsid. Each viral capsid consists of 252 capsomeric units, of which 240 are hexons and 12 are pentons (Ginsberg et al. 1966). The pentons form a base for the protruding fiber protein (Norrby 1966; Norrby and Skaaret 1967). The penton base and fiber protein play an essential role in attachment and entry of the HAdV particles into target cells. Specifically for HAdV type 5, the fiber protein interacts with the coxsakievirus and adenovirus host receptor (CAR) which is commonly found on the surface of epithelial cells. Upon subsequent interaction of the arginine-glycine-aspartic acid (RGD) motif in the penton base with cellular integrins such as $\alpha\beta3$ and $\alpha\beta5$, the virus particle is taken up via phagocytosis (Wickham et al. 1993; Meier and Greber 2004). However, not all adenoviruses contain the RGD motif, and therefore exhibit altered specificity for different cellular receptors (Wickham et al. 1995; Albinsson and Kidd 1999).

All HAdVs contain a linear dsDNA genome of approximately 36 kbp in length with highly conserved organization (Figure 1.1). The genome contains inverted terminal repeats (ITRs) at each end (Steenbergh et al. 1977) and is capped with a 55 kilo Dalton (kDa) terminal protein at each genomic 5' terminus (Rekosh et al. 1977). This covalently attached terminal protein functions as a primer during viral DNA replication and may provide protection for the viral genome from host DNA damage response

Group	Hemagglutination	Serotypes	Oncogenic Potential		% of G-C in DNA
			Tumors in animals	Transformation in tissue culture	
A	(little or no agglutination)	12,18,31	High	+	48-49
B	(complete agglutination of monkey erythrocytes)	3,7,11,14,16 21,34,35,50	Moderate	+	50-52
C	(partial agglutination of rat erythrocytes)	1,2,5,6	Low or none	+	57-59
D	(complete agglutination of rat erythrocytes)	8,9,10,13,15 17,19,20,22-30 32,33,36-39 42-49,51	Low or none	+	57-61
E		4	Low or none	+	57-59
F		40,41	Unknown	+	50-51
G		52	Unknown	N/A	55.1

Figure 1.2 Classification of HAdV Species

HAdVs were originally separated into 6 species based on a number of criteria including hemagglutination of erythrocytes and oncogenic potential both *in vivo* and *in vitro*. More recently, genome sequencing of HAdVs has confirmed previous serotype classification and a 7th species was identified. Figure adapted from Fields Virology, 6th Edition: Adenoviridae.

elements that normally recognize free ends of damaged DNA (Stracker et al. 2002; Weitzman and Ornelles 2005; Karen et al. 2009). The viral genome has been given arbitrary directionality and the viral genes are encoded on both DNA strands. There are nine transcriptional units that comprise two classes: early genes and late genes. Early genes are produced before the onset of viral genome replication, and are generally responsible for preparing the cell for virus production and evasion of the host immune response. Late genes are produced after viral genome replication and code for structural proteins that make up the viral capsid (Tollefson et al. 2007; Berk 2013).

1.2.2 The genes and life cycle of adenoviruses

The primary focus of the research presented in this thesis is focused largely on HAdV5 and hence forth, except where noted, the following background pertains to viruses of this type. The virus life cycle begins with contact and attachment to the host cell via the knob of the fiber protein and subsequent receptor-mediated endocytosis through the binding of the RGD sequence found in the penton base to $\alpha\beta3$ and $\alpha\beta5$ integrins (Williams et al. 1975; Varga et al. 1991). Acidification of the early endosome releases the virus particle into the cytosol (Mellman 1992), where it is uncoated, releasing the viral core containing the viral genome (Lonberg-Holm and Philipson 1969). The core is then trafficked via the cellular microtubule network to the nucleus, where transcription of early viral transcripts begins (Lonberg-Holm and Philipson 1969; Chardonnet and Dales 1972; Dales and Chardonnet 1973).

The first gene to be transcribed from the viral genome is E1A. E1A is the main focus of this thesis and will be discussed later in detail. In short, E1A possesses the critical functions of driving the infected cell into S-phase to create an optimal environment for viral replication and activating the transcription of other early viral genes. (Frisch and Mymryk 2002; Pelka et al. 2008; Berk 2013). The E1 region of HAdV also contains the Early Region 1 B (E1B) gene, which codes for two proteins of 55kDa and 19kDa in size (in the context of HAdV5). The major function of these proteins is to inhibit the functions of the p53 tumor suppressor and to block apoptosis that is stimulated by the effects of E1A (Yew and Berk 1992; Berk 2013). E1B-55k functions as a cullin5-containing E3 ubiquitin-ligase complex, promoting ubiquitination and subsequent degradation of p53

(Querido et al. 2001; Harada et al. 2002; Blanchette et al. 2004). E1B-55k also acts as a viral small ubiquitin-like modifier (SUMO) ligase to modify p53, forcing p53 nuclear export via an interaction with cellular promyelocytic leukemia nuclear bodies (PML) (Muller and Dobner 2008; Pennella et al. 2010). This dual-specificity results in maximal inhibition of p53. At later stages of the infection, E1B-55K works in concert with HAdV Open Reading Frame (ORF) E4-ORF6 to export viral mRNA from the nucleus into the cytoplasm in order to facilitate late mRNA translation by recruiting the Nxf1/Tap export receptor (Gonzalez and Flint 2002; Gonzalez et al. 2006; Yatherajam et al. 2011). The smaller product, E1B-19k, is a Bcl2-homologue that inhibits apoptosis by binding to cellular BAK and BAX, thereby blocking cytochrome-c release from the mitochondria (Rao et al. 1992; Chiou et al. 1994; Farrow et al. 1995).

The E2 region contains three genes that code for three proteins involved in replication of the viral genome. This includes the DNA-dependent DNA polymerase, the single stranded DNA binding protein, and the terminal protein (van der Vliet and Levine 1973; Levine et al. 1976; Challberg and Kelly 1979). As mentioned above, the terminal protein acts as a primer to initiate viral DNA replication (Kelly and Lechner 1979). Viral DNA replication continues in the standard 5' to 3' direction by the viral DNA-dependent DNA polymerase. As single stranded intermediates are produced, they are bound by the viral single stranded DNA binding protein to prevent degradation. Progeny genomes are later capped with the terminal protein and can then serve as templates for additional replication (van der Vliet and Levine 1973; Kelly and Lechner 1979; Challberg and Kelly 1981; van Breukelen et al. 2003). The E3 region of the HAdV genome is composed of one differentially spliced transcript coding for six unique protein products. These proteins are involved in protecting the infected cell by modulating the host immune system at both the innate and adaptive level. These include the receptor internalization and degradation complex (RID $\alpha\beta$), gp19K, 14.7K, 12.5K, 6.7K, and the adenovirus death protein (ADP) (Wold and Ison 2013). RID $\alpha\beta$ is involved in blocking extrinsic death ligand signals such as TNF (tumour necrosis factor) (Benedict et al. 2001; Friedman and Horwitz 2002), Fas (TNF superfamily, member 6) ligand (Shisler et al. 1997; Elsing and Burgert 1998; Tollefson et al. 1998), and TRAIL (TNF-related apoptosis-inducing ligand) (Tollefson et al. 2001). The gp19K glycoprotein is involved in downregulation of surface expression of

Major Histocompatibility Complex I (MHCI) on infected cells (Burgert and Kvist 1985; Burgert et al. 1987; Korner and Burgert 1994). The viral protein 14.7K is involved in binding and inhibiting the apoptotic activity of TNF, NF- κ B, and Caspase 8 (Krajcsi et al. 1996; Klingseisen et al. 2012). The 6.7K viral protein functions together with RID $\alpha\beta$ to downregulate TRAIL and TNF signaling via blocking arachidonic acid release (Benedict et al. 2001; Moise et al. 2002). Unlike the other E3-region proteins, the adenovirus death protein is expressed at late times during infection and has pro-apoptotic activity that plays a large role in mediating cell lysis for release of progeny virus (Tollefson et al. 1992; Tollefson et al. 1996). Finally, the 12.5K protein has no known function and is not required for virus replication despite being highly conserved among HAdV types (Hawkins and Wold 1992).

The final early region of the HAdV genome is E4, which is composed of one mRNA transcript that is differentially spliced to encode several protein products with diverse functions. E4ORF1 and E4ORF4 activate the protein kinase mTOR (O'Shea et al. 2005). Specifically, E4ORF1 activates mTOR by activating PI3K (phosphatidylinositol 3-kinase) through interactions with cellular PDZ-domain-containing proteins at the plasma membrane (Frese et al. 2003; O'Shea et al. 2005; Chung et al. 2008). These E4ORF1-PDZ interactions also play a critical role in oncogenic transformation of subgroup D HAdV, however the molecular mechanism is not well understood (Chung et al. 2007). E4orf4 activates mTOR by binding to and retargeting the global cellular phosphatase PP2A, which enhances viral replication, even under nutrient/growth factor-limiting conditions (O'Shea et al. 2005). E4ORF3 plays an important role in the inactivation of several tumor suppressors including p53, as well as inhibiting the cellular DNA double-stranded break responses (DSBR) by sequestering the MRN DNA damage complex (MRE11/RAD50/NBS1) in a similar manner to that of E1B-55K (Stracker et al. 2002; Ullman et al. 2007; Sohn and Hearing 2012). As described previously, E4ORF6 works in conjunction with E1B-55K and plays a role in viral DNA replication, RNA processing, viral mRNA transport, and prevention of cellular protein production (Halbert et al. 1985; Huang and Hearing 1989; Bridge and Ketner 1990; Yatherajam et al. 2011).

The gene products of the early viral transcription units work in tandem to provide an optimal cellular environment for the virus, induce viral DNA replication, protect the genome from destruction and evade the immune response. Following viral DNA replication, the adenoviral late gene region is expressed. The HAdV late transcript is differentially spliced and codes for structural and non-structural proteins which are involved in virion assembly, packaging and egress (Berk 2013). In these final stages, the virus is assembled in the nucleus and the cell is eventually lysed, releasing viral progeny that can infect new hosts.

1.3 Human adenovirus early region 1A (E1A)

1.3.1 The adenovirus E1A gene, transcripts, and protein products

The adenovirus E1A gene is located at the extreme left end of the viral genome, downstream of the left ITR (Figure 1.1). E1A is the first viral gene expressed after infection (Nevins et al. 1979) and is necessary for a productive viral infection at low multiplicities of infection (Jones and Shenk 1979). This gene functions by activating viral early gene transcription, reprogramming host cell gene expression, forcing quiescent cells to enter S-phase, blocking cell differentiation and suppressing the inflammatory response (Bayley and Mymryk 1994; Flint and Shenk 1997; Gallimore and Turnell 2001; Berk 2005). The E1A transcript is differentially spliced to yield five isoforms, 13S, 12S, 11S, 10S, and 9S, which were named based on their sedimentation coefficients (Figure 1.3A). The two largest E1A isoforms, 13S and 12S, are expressed at high levels early in infection, while at later times during infection, an increase in the production of the 11S, 10S, and 9S mRNA species occurs (Stephens and Harlow 1987). The early proteins encode 289 and 243 residue products in HAdV5, respectively, differing only by a 46 amino acid sequence that is unique to the larger isoform (Figure 1.3B). Both of these protein products localize to the nucleus and the cytoplasm and carry out the majority of the known functions of E1A. The later E1A species encode proteins of 217, 171, and 55 residues, respectively in HAdV5 (Stephens and Harlow 1987; Ulfendahl et al. 1987) (Figure 1.3B). The precise roles of these later splice products remain elusive, however, recently our lab showed that 9S E1A was able to activate the expression of HAdV viral

genes during infection and could also promote productive replication of species C HAdV (Miller et al. 2012).

Sequence comparisons of the largest E1A proteins of different adenovirus types identified four regions of sequence similarity, that have been designated conserved regions (CR) 1, 2, 3 and 4 (van Ormondt and Hesper 1983; Kimelman et al. 1985; Avvakumov et al. 2002; Avvakumov et al. 2004) (Figure 1.4). The conservation of these sequences tends to support the concept that each has specific functions that are critical for the viral life cycle.

1.3.2 E1A is an unstructured viral hub protein which contains many short linear interaction motifs

E1A contains no specific DNA binding capability or any enzymatic activity (Chatterjee et al. 1988; Zu et al. 1992; Avvakumov et al. 2002). Instead, E1A carries out its functions by interacting with and manipulating a plethora of key cellular regulatory proteins that are involved in cell cycle regulation and transcriptional control. E1A alters or inhibits the functions of these cellular targets, which leads to a reprogramming of the cellular environment to benefit the virus. While most proteins typically have one or two interacting partners, about 50 distinct protein targets have been reported to interact with E1A. Hence, E1A is referred to as a viral hub protein. Interestingly, some of E1A's targets themselves are cellular hub proteins that undergo many cellular protein-protein interactions and therefore modulate many cellular processes. These include proteins such as the cellular transcriptional activator p300/CBP (CREB binding protein), and the retinoblastoma susceptibility gene product (pRb) tumor suppressor (Pelka et al. 2008). By targeting cellular hub proteins, E1A obtains a broad grasp on the cellular protein interaction network resulting in the manipulation of a maximum number of cellular pathways (Figure 1.5). The success of this strategy was exemplified even further in 2008, when it was discovered that remarkably, E1A is recruited to more than 17,000 host cell promoters during infection, which leads to a precise redistribution of transcriptional co-regulators to ultimately benefit the virus (Ferrari et al. 2008; Horwitz et al. 2008).

How E1A is able to bind to such a large number of cellular targets is related to its structure, or lack thereof. E1A is thought to be an intrinsically disordered protein, and to date, there is no known crystal or solution structure for the E1A protein. *In silico* prediction software such as PONDER (Garner et al. 1999; Romero et al. 2001), which predicts secondary and tertiary protein structure, reveals that E1A is almost entirely unstructured, and this was also confirmed experimentally by NMR (Nuclear magnetic resonance) (Ferreon et al. 2009). This is a common trait for proteins that interact with a large number of target proteins (Dunker et al. 2005; Kim et al. 2008). Intrinsically disordered proteins are able to bind to a large number of proteins through short linear interaction motifs (SLIMs). E1A is no exception to this strategy, as it is essentially comprised of a string of SLIMs that confer the interaction with its cellular targets. These SLIMs are typically found within the conserved regions of E1A (CR1-4) (Figure 1.6). For example, E1A's interaction with pRb identified the SLIM DLxCxE (where x represents a variable amino acid) is found in CR2 (Morris and Dyson 2001), while the interaction with the C-terminal binding protein (CtBP) requires the SLIM PxDLS and is found in CR4 (Chinnadurai 2002). In addition, the interaction with the zinc finger MYND domain-containing protein 11 (ZMYND11, which is also referred to as BS69) requires the motif PxLxP (Ansieau and Leutz 2002) in CR2, while the interaction with CBP/p300 requires the motif FXD/EXXXL (O'Connor et al. 1999) found in CR1. Each of those SLIMs were originally identified in HAdV-5 E1A, but have also been shown to be present in cellular proteins that also interact with E1A targets (Figure 1.6). The interaction of E1A with its targets has been used as an extremely powerful molecular tool to better understand the cellular processes regulated by these cellular regulatory proteins.

1.3.3 Depending on the context, E1A can act as an oncoprotein or tumour suppressor

The modulation of cellular hub proteins leading to drastic alterations in the molecular control of cell proliferation is also a common phenomenon in many cancers. Indeed, viral hub oncoproteins such as E1A have been invaluable tools in identifying potential cellular proteins that may be involved in cancer and help provide an understanding of the process of cellular transformation and tumourigenesis (Rozenblatt-Rosen et al. 2012).

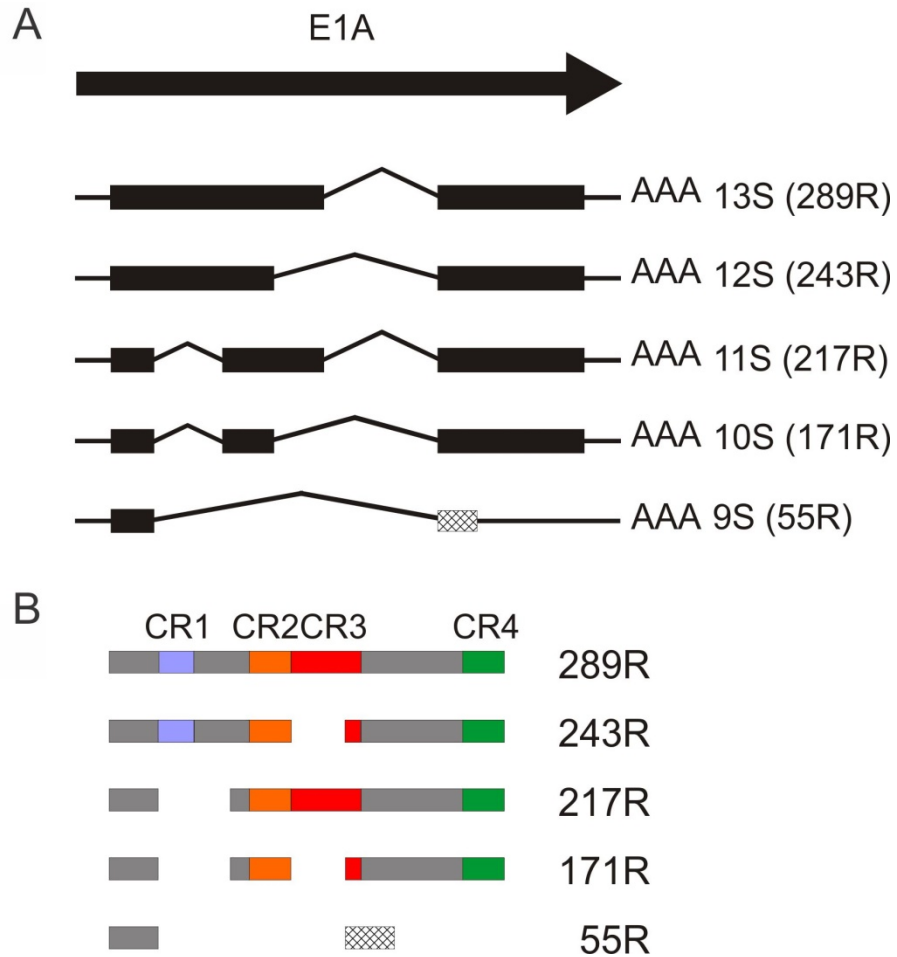

Figure 1.3 E1A splice products

(A) The E1A transcript is differentially spliced into 5 products: 13S, 12S, 11S, 10S, and 9S, which are named based on their sedimentation coefficients. Black bars represent the coding RNA while the lines represent the removed RNA. All splice events maintain the translational reading frame with the exception of the 9S product (denoted by the checkered bar). (B) Diagrammatic representation of the protein splice products. Conserved regions 1-4 are labeled and denoted by blue, orange, red, and green boxes, respectively. The unique sequence in the 55R protein of the 9S mRNA is denoted by the checkered bar.

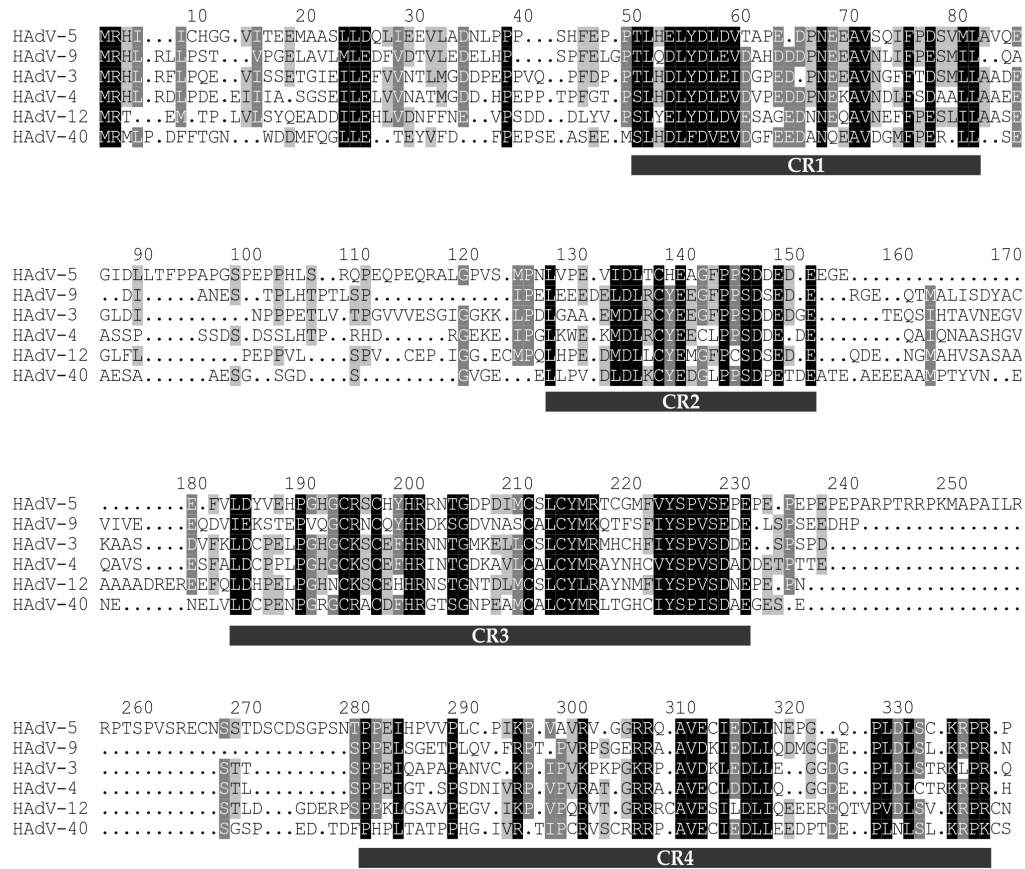

Figure 1.4 Alignment of selected E1A proteins from different HAdV species

The amino acid sequences of the largest E1A proteins of HAdV-5, 3, 9, 4, 12 and 40, which represent the six HAdV species, were aligned and are shaded with respect to their conservation. Gaps are indicated as dots. The positions of the conserved regions (CRs) are indicated as solid bars.

The end result of HAdV infection in humans is cell lysis, which leads to the release of viral progeny. Therefore, these viruses are not generally thought to cause cancer in humans. However primary human cells can be transformed by transfection of adenoviral DNA (Whittaker et al. 1984). HAdV infection of rodent cells, in contrast to human cells, does not result in cell death and is a non-productive infection due to inefficient viral DNA synthesis and a deficiency in late viral protein production (Whittaker et al. 1984). E1A alone is sufficient to immortalize primary rodent cells and is capable of fully transforming rodent cells in cooperation with a second oncogene, such as HAdV E1B or activated Ras (Bayley and Mymryk 1994; Gallimore and Turnell 2001). Paradoxically, E1A can also function as a tumour suppressor when expressed in previously transformed human and animal cells. It can reduce metastasis, induce apoptosis and convert cells from a mesenchymal-like to an epithelial-like cell type (Deng et al., 2002; Frisch and Mymryk, 2002; Mymryk, 1996).

1.3.4 The four regions of E1A

The modular nature of E1A also allows for mutational analysis, as insertions or deletions typically affect only certain functions while other functions remain intact (Bayley and Mymryk 1994). Furthermore, small fragments of E1A can retain their function when expressed in isolation. Therefore, each conserved region of E1A can be considered a functional module, which has allowed for extensive targeted studies of individual modules. A description of the regions of E1A is provided below.

1.3.4.1 The E1A N-terminus/Conserved Region 1

In HAdV5 E1A, the N-terminal region spans residues 1-41 and CR1 spans amino acids 42-72 (Avvakumov et al. 2004). To date there are 15 cellular proteins known to bind to the N-terminal region of E1A. Most of these targets are involved in transcription, including activating protein-2 (AP2) (Somasundaram et al. 1996), thyroid hormone receptor (TR) (Meng et al. 2003), and most importantly p300/CREB Binding Protein (CBP) (Eckner et al. 1994; Arany et al. 1995). The E1A-p300/CBP interaction leads to global changes in p300/CBP occupancy of almost 70% of the cellular promoters in infected cells and leads to global acetylation of histone H3 lysine 18 (H3K18) (Ferrari et

al. 2008; Horwitz et al. 2008). The N-terminus of E1A also interacts with cellular proteins that are involved in signaling networks including Ran GTPase (De Luca et al. 2003), the protein kinase Nek9 (Pelka et al. 2007) and Protein Kinase A (PKA) (Fax et al. 2001). CR1 cooperates with the N-terminus to bind common cellular targets including p300/CBP (Egan et al. 1988; Stein et al. 1990; Wong and Ziff 1994). CR1 also interacts with pRb via the E2F binding site found in pRb via molecular mimicry (Liu and Marmorstein 2007). Although this is a low affinity interaction in comparison to the high-affinity site found in CR2, CR1 has been shown to be critical for dissociating pRb from E2F transcription factors, which subsequently leads to S phase induction (Fattaey et al. 1993; Ikeda and Nevins 1993). More recently, our lab discovered that a novel interaction between E1A and the human E3 ubiquitin-protein ligase Bre1 (hBre1) plays a crucial role in overcoming the cellular type I interferon (IFN) host defense response during HAdV infection (Fonseca et al. 2012). The N-terminal region of E1A binds to and dissociates the hBre1 complex, blocking IFN-induced monoubiquitination of histone 2B (H2B) and associated interferon-stimulated gene (ISG) expression (Fonseca et al. 2012). Furthermore, this interaction recruits human Paf1 to aid in E1A-mediated transcriptional activation and transcriptional elongation (Fonseca et al. 2013; Fonseca et al. 2014). Overall, the cellular interactions made at the N-terminus of E1A and CR1 play an essential role in E1A-mediated transcriptional activation/repression, S phase induction, and evasion of the antiviral response.

1.3.4.2 The E1A Conserved Region 2

CR2 is one of the most well studied regions of E1A. It spans residues 115-137 and includes the DLXCXE SLIM that confers the high-affinity interaction with pRb (Avvakumov et al. 2004). The interaction between E1A and pRb is the first documented example of an oncoprotein interacting with a tumour-suppressor (Whyte et al. 1988). CR2 is required for the virus to be able to force quiescent cells to enter the S phase of the cell cycle, the activation of viral genes, and to induce oncogenic transformation in rodent cells in culture. These functions are largely carried out through the interaction with pRb and family members p107 and p130 (Flint and Shenk 1997; Gallimore and Turnell 2001; Berk 2005). CR2 also interacts with the SUMO conjugase named ubiquitin conjugase 9

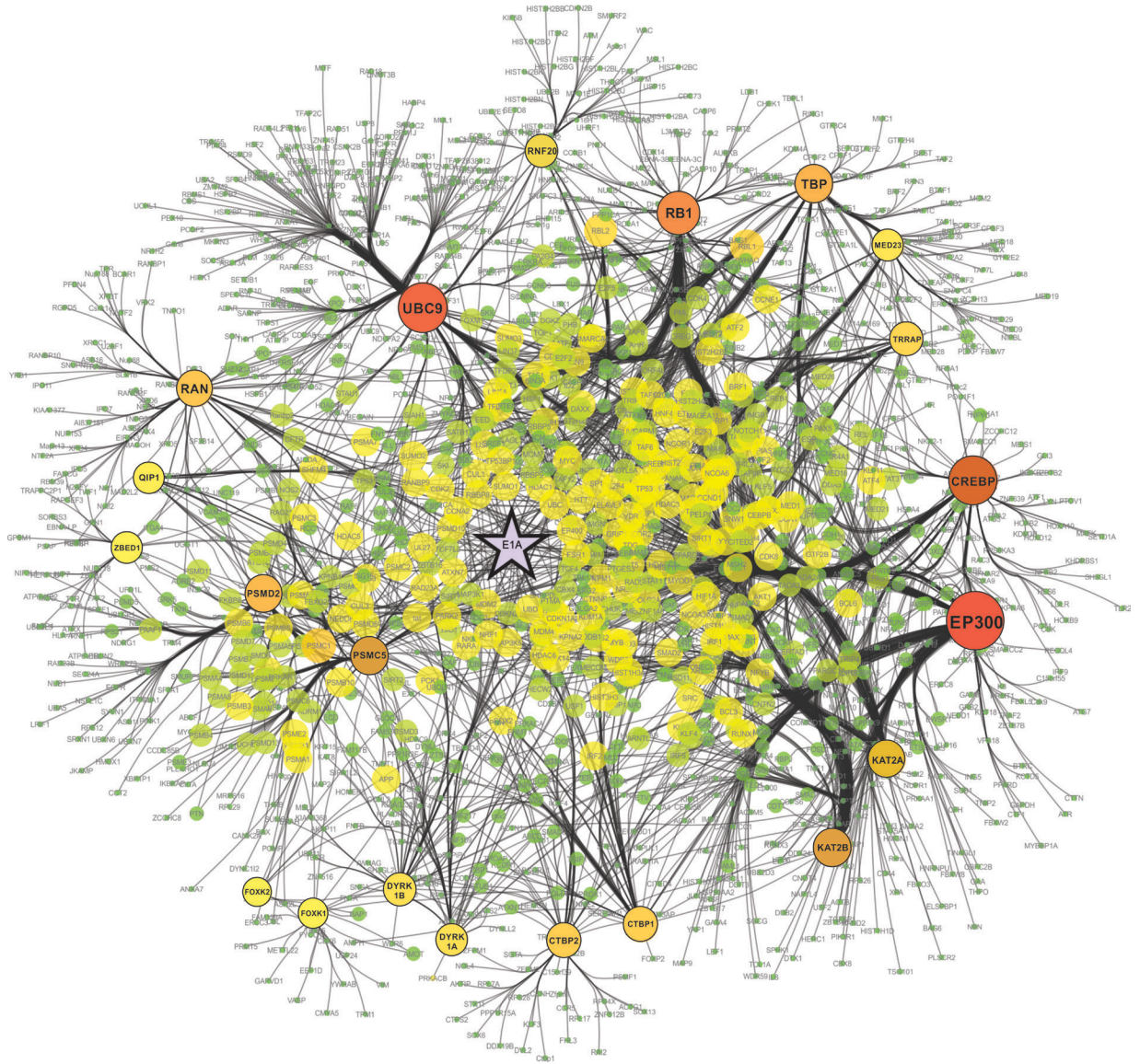

Figure 1.5 The HAdV E1A Interactome

Protein interaction network of E1A and its 28 high-confidence binding partners. Interaction data was extracted from the BioGRID database and the network was created using the Cytoscape software. Size of the circles and the darkness of colour represents the number of connections made by each protein. Select cellular hub proteins are highlighted by bold text.

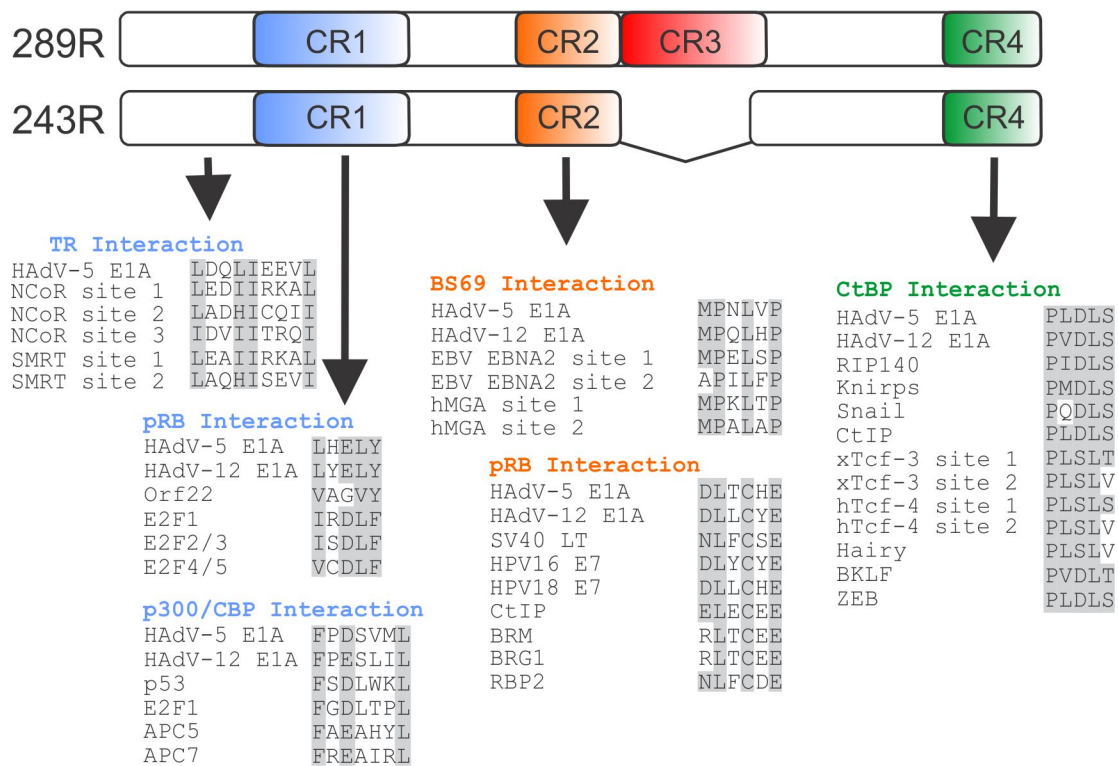

Figure 1.6 Map of E1A conserved regions and the location of selected linear interaction motifs

Selected short linear protein interaction motifs that have been identified within E1A are shown. The E1A sequence and the sequences of other viral and cellular proteins that also use this SLIM for interaction with the target protein are also indicated. Sequence shading indicates residues associated with the consensus of the indicated linear interaction motif.

Figure adapted from Pelka et. al., 2008.

(UBC9), BS69, and the S2 component of the 19S subunit of the 26S proteasome (Pelka et al. 2008). UBC9 binds to the EVIDLT SLIM corresponding to residues 118-123 in HAdV5 E1A. This interaction mimics the normal binding between SUMO-1 and the N-terminus of UBC9 thereby blocking SUMO chain formation (Yousef et al. 2010). BS69 is a transcriptional repressor that is involved in cell cycle control and senescence (Hughes-Davies et al. 2003; Wan et al. 2006; Zhang et al. 2007). It was originally identified as an E1A interacting protein that represses transcriptional activation by E1A CR3 and stabilizes E1A by blocking its ubiquitination (Hateboer et al. 1995; Isobe et al. 2006). BS69 binds to the PXLXP SLIM, spanning residues 112-117 in HAdV5 E1A, which is only found in HAdV species A and C (Types 12, 18, 31 and 1, 2, 5, 6 respectively) (Avvakumov et al. 2004). Finally, the S2 component of the 19S regulatory subunit of the 26S proteasome binds to residues 124-147 in CR2 of HAdV5 E1A (Zhang et al. 2004). This interaction disrupts normal proteasome activity and in turn, stabilizes p53 and sensitizes cells to TNF- α (Turnell et al. 2000).

1.3.4.3 The E1A Conserved Region 3

The E1A CR3 region is found within the unique 46 residue sequence that spans residues 144-191 of HAdV5 13S E1A and is not present in 12S E1A. It contains a C4 zinc finger and functions as a potent transcriptional activator that is essential for the transcription of the early viral genes (Culp et al. 1988; Gonzalez and Flint 2002). Unlike the other regions of E1A, almost any deletion within the CR3 region leads to a loss of function as a transcriptional activator (Glenn and Ricciardi 1985; Lillie et al. 1986; Moran et al. 1986). Furthermore, no SLIMs have been identified in this region. Hence, it has been suggested that CR3 is a more ordered region of E1A and maintains a structure that is required for its transcriptional activity. However, the structure of this region of E1A remains unknown.

The zinc finger domain of CR3 interacts with two critical targets, cellular TBP and a component of the mediator adaptor complex, MED23 (Webster and Ricciardi 1991; Geisberg et al. 1994; Boyer et al. 1999). These interactions enable CR3 to recruit transcriptional activation complexes for E1A-dependent virus early gene transcription. CR3 also interacts with co-activators SUG1 and p300 (Rasti et al. 2006; Pelka et al. 2009) as well as transcriptional repressors such as the histone acetyltransferase (HAT)

GCN5 and BS69 (Hateboer et al. 1995; Masselink and Bernardts 2000; Ablack et al. 2010). Together, the interactions carried out by CR3 work in concert to form an unusually potent transcriptional activation domain that is required to maximize virus replication.

1.3.4.4 The E1A C-terminus and Conserved Region 4

The C-terminus and CR4 of E1A is a major focus of this thesis. For simplicity, these two regions will be referred to interchangeably throughout the remainder of the thesis, despite the fact that some regions of the C-terminus are not highly conserved between the E1A proteins of different HAdVs. The sequence, binding partners, and functions of this region of E1A are discussed in detail in section 1.4.

1.4 The C-terminus of E1A

Despite decades of HAdV E1A research, very little is known about the function and binding partners that associate with E1A via its C-terminus and this region has been considered the undiscovered country of E1A (Yousef et al. 2012). Interestingly, CR4 is required for transformation of primary rodent cells in combination with E1B (Subramanian et al. 1991; Douglas and Quinlan 1995), but also has the paradoxical ability to inhibit transformation in cooperation with activated Ras. A description of the cellular targets that associate with E1A via its C-terminus and the biological functions carried out by this region are described below.

1.4.1 The organization of the C-terminus of E1A

In HAdV-5 E1A, the C-terminal region of E1A is encoded by the second exon of the gene, which spans residues 187-289 (Figure 1.7). Residues 187-191 contains a portion of CR3 and following CR3, there are six repeats of the dipeptide amino acid sequence EP (residues 189-200), which is named Auxiliary Region 1 (AR1). This region plays a role in transcriptional activation by CR3 (Strom et al. 1998). AR1 is followed by a region unique to species C HAdV (residues 201-239). Finally, CR4 is found within residues 240-288 (Avvakumov et al., 2004).

1.4.2 Protein interactions mediated by the C-terminus of E1A

1.4.2.1 CtBP1/2

The best characterized interaction of the C-terminus of E1A is with CtBP, which was both identified and named based on its interaction with the C-terminus of E1A (Boyd et al. 1993). There are two CtBP family members, and both interact with E1A (Komorek et al. 2010). CtBP1/2 function as transcriptional corepressors that regulate the expression of genes involved in growth, tumorigenesis and apoptosis (Bergman and Blaydes 2006; Chinnadurai 2009). CtBP represses ZEB1 (Zinc Finger E-Box Binding Homeobox 1) dependent transcription (Postigo and Dean 1999), leading to a downregulation of genes such as E-cadherin and inducing an epithelial to mesenchymal transition (EMT) (Peinado et al. 2007). Furthermore, CtBP suppresses apoptosis by downregulating the expression of genes such as p21, and Bax (Grooteclaes et al. 2003). Multiple tumour suppressors target CtBP for degradation to induce apoptosis and/or cell cycle arrest (Zhang et al. 2003; Hamada and Bienz 2004; Sierra et al. 2006).

E1A binds to CtBP1/2 through the PXDLS SLIM spanning residues 279-283 in HAdV-5 E1A and is highly conserved among all HAdV types (Figure 1.4). Cellular proteins that bind CtBPs also contain this sequence (Pelka et al. 2008) and thus, E1A effectively inhibits CtBP targeting by competing with cellular PXDLS-containing factors, leading to a de-repression of cellular transcription (Frisch and Mymryk 2002).

1.4.2.2 FOXK1/2

FOXK1 and FOXK2 are members of the forkhead (FKH) family of transcription factors that affect many cellular processes, including differentiation (Hori et al. 2003) and cell cycle progression (Marais et al. 2010). FOXK1/2 act as transcriptional repressors, unlike many other FKH family members, and compete with the activating members of the FKH family for occupancy of target genes (Shi et al. 2010). FOXK1/K2 were recently identified as novel targets of the HAdV-5 E1A C-terminus through proteomic analysis (Komorek et al., 2010). This interaction maps to residues 224-238 of HAdV5 E1A in a region that is only found in species C HAdVs, but it is highly conserved between these species members.

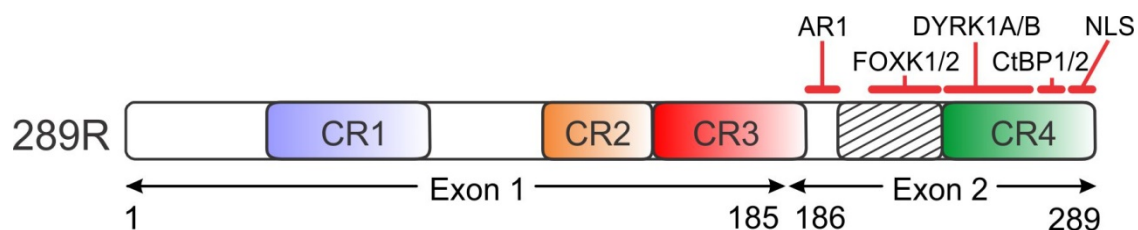

Figure 1.7 Map of the largest E1A protein and organization of the C-terminus of E1A

The second exon of E1A encodes 104 amino acids and contains part of CR3 and the entirety of CR4. The AR1 region, the relative location of the binding sites for FOXK1/2, DYRK1A/1B, CtBP1/2, and the nuclear localization sequence (NLS) are indicated. Note that the FOXK1/2 binding region is outside of CR4 (indicated by the hatched box). Figure adapted from Yousef et al. 2012

1.4.2.3 DYRK1A/1B and HAN11

The Dual-Specificity Tyrosine-Regulated Kinase (DYRK) family is composed of 5 proteins (DYRKs 1A/B and 2-4), with DYRK1A being the best characterized and most ubiquitously expressed (Becker et al., 1998). DYRK1A was originally identified because of its association with Down Syndrome, as the gene encoding DYRK1A is found on chromosome 21 and its expression is increased at both the transcript and protein level in these individuals (Park et al. 2009). Furthermore, truncation mutants of DYRK1A result in clinical phenotypes, including microcephaly and developmental delay (Moller et al. 2008). DYRKs autophosphorylate a tyrosine in their activation loop, as well as phosphorylate serine/threonine within their substrates. DYRK1A/B have been shown to phosphorylate and regulate a number of transcription factors including Gli1 and NFATc1, although many of their documented substrates have not been confirmed *in vivo* (Aranda et al. 2011). DYRK1A/B interact with HAN11 (Skurat and Dietrich 2004; Ritterhoff et al. 2010), the human orthologue of anthocyanin 11 (AN11), which controls flower pigmentation (de Vetten et al. 1997). Although not much is known about HAN11, it can function as a negative regulator of DYRK1A (Morita et al. 2006).

DYRK1A and DYRK1B function as survival kinases in a number of cancers (Lee et al. 2000; Deng et al. 2006; Chang et al. 2007; Jin et al. 2007). Mechanistically, DYRK1A can phosphorylate caspase-9, thereby inhibiting apoptosis (Laguna et al. 2008; Seifert et al. 2008). DYRK1A can also assist in p53-mediated cell survival during DNA damage by phosphorylating a p53 inhibitor, SIRT1 (Guo et al. 2010). DYRK1B inhibits apoptosis by phosphorylating p21, inducing transport into the cytosol where it blocks procaspase 3 activity (Mercer et al. 2005).

A yeast two-hybrid screen revealed that the C-terminal region of E1A interacts with the *Saccharomyces cerevisiae* homolog of DYRK1A, termed Yet Another Kinase 1 (Yak1) (Zhang et al. 2001). This same study also revealed that E1A binds to mammalian DYRK1A/1B and stimulates the kinase activity of DYRK1A *in vitro*. Residues 239-284 were required for the interactions, which overlaps with the CtBP1/2 binding site (Zhang et al. 2001). More recently a proteomics screen revealed that endogenous DYRK1A/B and their co-factor HAN11 interact with the C-terminus of E1A (Komorek et al., 2010).

1.4.2.4 Importin- α

It is essential for E1A to translocate from the cytoplasm into the nucleus to gain access to a large number of its cellular targets (Douglas and Quinlan 1995; Madison et al. 2002). Hence, E1A contains a highly conserved monopartite NLS mapped to the extreme C-terminus of E1A with the sequence KRPRP (residues 285-289 in HAdV5 E1A). This NLS preferentially interacts with importin- α 3 (also known as Qip1) to facilitate transport into the nucleus (Lyons et al. 1987; Kohler et al. 2001). The nuclear:cytoplasmic ratio of E1A is in part regulated by lysine acetyltransferases that interact with the N-terminal and CR1 regions of E1A such as CBP. They can acetylate residue K285 in the NLS, which inhibits the interaction with importin- α 3 and leads to an accumulation of E1A in the cytoplasm (Madison et al. 2002).

1.4.3 Immortalization and transformation with E1B

As mentioned previously, the expression of HAdV-5 E1A alone is sufficient to immortalize primary rodent cells in culture (Houweling et al. 1980). These cells can be fully transformed when co-expressed with HAdV E1B (Subramanian et al., 1991). In addition to the N-terminus/CR1 and CR2, the C-terminal region of E1A and CR4 is required for oncogenic transformation (Quinlan et al. 1988; Subramanian et al. 1991; Quinlan and Douglas 1992). Not surprisingly, efficient nuclear localization of E1A is required for immortalization by E1A as deletion of the C-terminal NLS of E1A reduces transformed foci yield by ~95% when co-expressed with E1B (Douglas and Quinlan 1994; Douglas and Quinlan 1995). Mutational analysis has shown that residues 240-289 of HAdV5 E1A are required for maximal immortalization (Quinlan and Douglas 1992; Boyd et al. 1993), as mutants lacking residues 241-254, 255-270 or 237-256 have a reduced ability to immortalize rodent cells (Boyd et al., 1993; Quinlan and Douglas, 1992). Therefore, the FOXK1/2 interaction does not appear to be required for

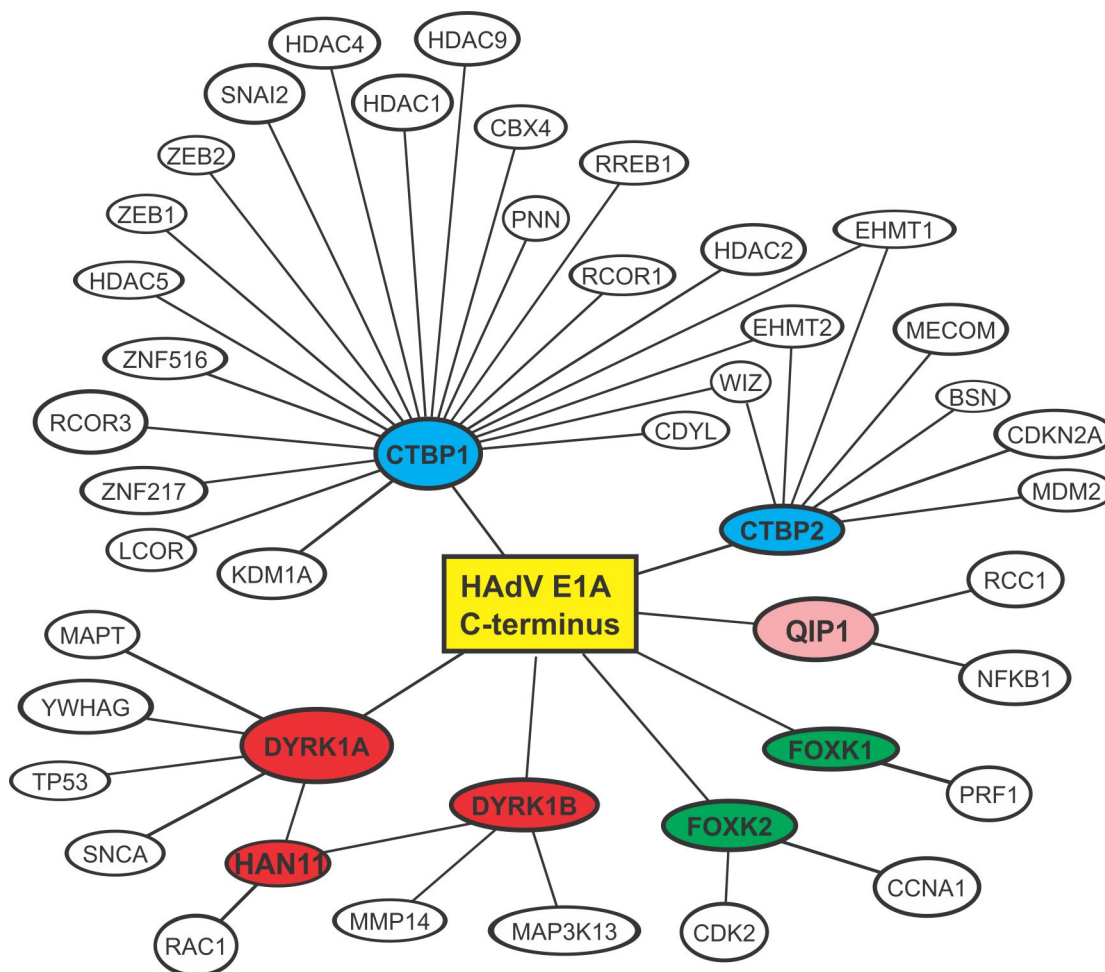

Figure 1.8 Protein interaction network of the C-terminal portion of E1A

A representation of the numerous connections made by the C-terminus of E1A by binding to its known cellular targets (coloured circles). The secondary interactions of the C-terminal targets (white circles) were identified from protein interaction databases. These proteins and their cellular processes may be potentially influenced by the C-terminus of E1A. Figure adapted from Yousef et al, 2012.

immortalization or transformation with E1B, but the other cellular targets of the C-terminal region of E1A likely play an important role in this activity.

1.4.4 Suppression of transformation and tumourigenesis with activated Ras

E1A can also cooperate with activated Ras to oncogenically transform baby rat kidney (BRK) cells (Ruley 1983). However, in this context, the C-terminal region of E1A is not required. Previous reports have shown that an E1A mutant lacking the C-terminal region leads to a "hypertransforming" phenotype that produces far more foci in cooperation with Ras than wildtype E1A (Subramanian et al. 1991). Extensive mutational analysis has indicated that any deletion within residues 224-285 of E1A leads to enhanced transformation with Ras, suggesting that disruption of any C-terminal interaction results in the loss of E1A-mediated suppression of transformation with Ras (Douglas et al. 1991; Boyd et al. 1993; Komorek et al. 2010).

The C-terminal region of E1A also plays an important role in the suppression of tumourigenesis and metastasis. BRK cells transformed using HAAdV-5 E1A and activated Ras cannot form tumours in syngeneic rats (Subramanian et al. 1989). Interestingly, BRK cells transformed with an E1A mutant lacking the C-terminal region generate tumours with 100% incidence following subcutaneous injection (Subramanian et al. 1989). Furthermore, BRK cells transformed by most C-terminal mutants have enhanced tumour growth and metastasis in athymic mice (Subramanian et al. 1989; Boyd et al. 1993). Suppression of tumourigenicity requires residues 239-285, but not residues 227-239 of E1A (Boyd et al. 1993), indicating that the DYRK1A/B and CtBP1/2 interactions likely play a role in these effects.

1.5 Thesis overview and rationale

The work within this thesis involves a systematic analysis of C-terminal region of E1A as a means of mapping this undiscovered country. Many questions remain regarding the functional mechanisms driving the cellular effects carried out by C-terminal region of E1A. For years, CtBP was the only known interacting protein that bound to this region of E1A. Previous mutational analysis suggested that CtBP plays a pivotal role in both E1A-

mediated transformation with E1B and antagonizing transformation with activated Ras (Subramanian et al. 1989; Subramanian et al. 1991; Schaeper et al. 1995). However, it was known that at least one other cellular factor is necessary for these activities, as there were CR4 mutants that retain CtBP binding but failed to transform with E1B or suppress transformation with Ras (Boyd et al. 1993). DYRK1A/1B, HAN11 and FOXK1/2 have now been identified as new targets for the C-terminal region of E1A. These discoveries add to the complexity of this region and expand upon the numerous connections that E1A can potentially make in the cellular protein-protein interaction network (Figure 1.8). Furthermore, we now know that the large deletion mutants used in previous studies disrupt the interaction of multiple C-terminal partners due to the overlapping binding sites of DYRK1A/1B, HAN11, and CtBP. This necessitates a more precise dissection of this region. Given the discovery of the new cellular targets, the mapping of the DYRK1A and HAN11 binding region (Komorek et al. 2010), and previous work suggesting that subcellular localization of E1A is critical (Douglas and Quinlan 1994; Douglas and Quinlan 1995), we sought to re-evaluate and further characterize the mechanism by which the C-terminus of E1A functions. The overall hypothesis for this thesis is that a precise and systematic mutational analysis of the C-terminal region of E1A will uncover the missing details necessary to understand the roles of the C-terminal targets of E1A in oncogenic transformation mediated by this viral oncoprotein.

1.5.1 Chapter 2: Dissection of the C-terminal region of E1A re-defines the roles of CtBP and other cellular targets in oncogenic transformation

In this study, we performed an extensive mutational analysis of the C-terminus of E1A as a means of identifying key residues that are specifically required for binding all known targets of the C-terminus of E1A. With these critical reagents in hand, we further tested each mutant for their ability to both localize to the nucleus and transform primary rat cells in cooperation with E1B-55K or Ras. Interaction of E1A with importin- α 3/Qip1, DYRK1A, HAN11 and CtBP influenced transformation with E1B-55K. Interestingly, the interaction of E1A with DYRK1A and HAN11 appears to play a role in suppression of transformation by activated Ras whereas interaction with CtBP was not necessary. This

unexpected result suggests a need for revision of current models and provides new insight into transformation by the C-terminus of E1A.

1.5.2 Chapter 3: Functional analysis of the C-terminal region of human adenovirus E1A reveals a misidentified nuclear localization signal

Following the previous chapter, we further examined the C-terminal NLS given that the immortalizing function of E1A requires efficient localization to the nucleus. During our analysis described in Chapter 2 we observed that an amino acid substitution upstream of the E1A NLS (R262/263E) resulted in a deficiency in nuclear localization. Furthermore, a bipartite NLS was predicted at this region *in silico*. In this study, we used immunofluorescence microscopy and co-immunoprecipitation analysis with importin- α to verify that full nuclear localization of E1A requires the well characterized NLS spanning residues 285-289, as well as a second basic patch situated between residues 258-263 (**RVGGRRQAVECIEDLLNEPGQPLDLSC**K**RPRP**). Thus, the originally described NLS located at the C-terminus of E1A is actually a bipartite signal, which had been misidentified in the existing literature as a monopartite signal, altering our understanding of one of the oldest documented NLSs.

1.5.3 Chapter 4: Investigating the functional mechanism by which the cellular targets of the C-terminal region of E1A modulate E1A-dependent transformation.

The work to be described in chapters 2 and 3 has helped determine which interactions are critical for oncogenic transformation mediated by the C-terminal region of E1A. Nevertheless, the molecular mechanisms by which these C-terminal targets aid in E1A function are still not well understood. We hypothesize that E1A manipulates downstream targets of the C-terminal interacting proteins, which contributes to oncogenic transformation. As a means of identifying both known and potentially novel secondary targets involved in transformation by E1A, we are currently investigating the global changes in gene expression between cells infected with either a wildtype virus, or a panel of mutant viruses expressing E1A that fail to interact with FOXK1/2, DYRK1A/HAN11 or CtBP1/2. First, we engineered a genomic adenovirus with a mutation in E1A that

abrogates DYRK1A binding and one that inhibits the CtBP interaction. Next, RNA from IMR90 primary lung fibroblast cells infected with wildtype HAdV5, a Δ E1A virus, a virus deficient in FOXK1/2 binding, or the newly constructed Δ DYRK1A- and Δ CtBP-binding viruses was collected and sent to the University of California San Diego Genomics Center for next generation whole transcriptome RNA sequencing (RNAseq). The analyses of these results are currently ongoing and a preliminary analysis of this large data set is presented here.

1.6 References

- Ablack, J. N., P. Pelka, A. F. Yousef, A. S. Turnell, R. J. Grand and J. S. Mymryk (2010). "Comparison of E1A CR3-dependent transcriptional activation across six different human adenovirus subgroups." *J Virol* **84**(24): 12771-81.
- Albinsson, B. and A. H. Kidd (1999). "Adenovirus type 41 lacks an RGD alpha(v)-integrin binding motif on the penton base and undergoes delayed uptake in A549 cells." *Virus Res* **64**(2): 125-36.
- Ansieau, S. and A. Leutz (2002). "The conserved Mynd domain of BS69 binds cellular and oncoviral proteins through a common PXLXP motif." *J Biol Chem* **277**(7): 4906-10.
- Aranda, S., A. Laguna and S. de la Luna (2011). "DYRK family of protein kinases: evolutionary relationships, biochemical properties, and functional roles." *Faseb J* **25**(2): 449-62.
- Arany, Z., D. Newsome, E. Oldread, D. M. Livingston and R. Eckner (1995). "A family of transcriptional adaptor proteins targeted by the E1A oncoprotein." *Nature* **374**(6517): 81-4.
- Avvakumov, N., A. E. Kajon, R. C. Hoeben and J. S. Mymryk (2004). "Comprehensive sequence analysis of the E1A proteins of human and simian adenoviruses." *Virology* **329**(2): 477-92.
- Avvakumov, N., M. Sahbegovic, Z. Zhang, M. Shuen and J. S. Mymryk (2002). "Analysis of DNA binding by the adenovirus type 5 E1A oncoprotein." *J Gen Virol* **83**(Pt 3): 517-24.
- Avvakumov, N., R. Wheeler, J. C. D'Halluin and J. S. Mymryk (2002). "Comparative sequence analysis of the largest E1A proteins of human and simian adenoviruses." *J Virol* **76**(16): 7968-75.

- Bayley, S. and J. Mymryk (1994). "Adenovirus e1a proteins and transformation (review)." Int J Oncol **5**(3): 425-44.
- Benedict, C. A., P. S. Norris, T. I. Prigozy, J. L. Bodmer, J. A. Mahr, C. T. Garnett, F. Martinon, J. Tschopp, L. R. Gooding and C. F. Ware (2001). "Three adenovirus E3 proteins cooperate to evade apoptosis by tumor necrosis factor-related apoptosis-inducing ligand receptor-1 and -2." J Biol Chem **276**(5): 3270-8.
- Bergman, L. M. and J. P. Blaydes (2006). "C-terminal binding proteins: emerging roles in cell survival and tumorigenesis." Apoptosis **11**(6): 879-88.
- Berk, A. (2013). Adenoviridae. (Philadelphia: Lippincot - Raven), Philadelphia: Wolters Kluwer Health/Lippincott Williams & Wilkins.
- Berk, A. J. (2005). "Recent lessons in gene expression, cell cycle control, and cell biology from adenovirus." Oncogene **24**(52): 7673-85.
- Blanchette, P., C. Y. Cheng, Q. Yan, G. Ketner, D. A. Ornelles, T. Dobner, R. C. Conaway, J. W. Conaway and P. E. Branton (2004). "Both BC-box motifs of adenovirus protein E4orf6 are required to efficiently assemble an E3 ligase complex that degrades p53." Mol Cell Biol **24**(21): 9619-29.
- Boyd, J. M., T. Subramanian, U. Schaeper, M. La Regina, S. Bayley and G. Chinnadurai (1993). "A region in the C-terminus of adenovirus 2/5 E1a protein is required for association with a cellular phosphoprotein and important for the negative modulation of T24-ras mediated transformation, tumorigenesis and metastasis." Embo J **12**(2): 469-78.
- Boyer, T. G., M. E. Martin, E. Lees, R. P. Ricciardi and A. J. Berk (1999). "Mammalian Srb/Mediator complex is targeted by adenovirus E1A protein." Nature **399**(6733): 276-9.
- Bridge, E. and G. Ketner (1990). "Interaction of adenoviral E4 and E1b products in late gene expression." Virology **174**(2): 345-53.
- Burgert, H. G. and S. Kvist (1985). "An adenovirus type 2 glycoprotein blocks cell surface expression of human histocompatibility class I antigens." Cell **41**(3): 987-97.
- Burgert, H. G., J. L. Maryanski and S. Kvist (1987). "'E3/19K" protein of adenovirus type 2 inhibits lysis of cytolytic T lymphocytes by blocking cell-surface expression of histocompatibility class I antigens." Proc Natl Acad Sci U S A **84**(5): 1356-60.
- Challberg, M. D. and T. J. Kelly, Jr. (1979). "Adenovirus DNA replication in vitro: origin and direction of daughter strand synthesis." J Mol Biol **135**(4): 999-1012.

- Challberg, M. D. and T. J. Kelly, Jr. (1981). "Processing of the adenovirus terminal protein." J Virol **38**(1): 272-7.
- Chang, H. S., C. H. Lin, C. H. Yang, M. S. Yen, C. R. Lai, Y. R. Chen, Y. J. Liang and W. C. Yu (2007). "Increased expression of Dyrk1a in HPV16 immortalized keratinocytes enable evasion of apoptosis." Int J Cancer **120**(11): 2377-85.
- Chardonnet, Y. and S. Dales (1972). "Early events in the interaction of adenoviruses with HeLa cells. 3. Relationship between an ATPase activity in nuclear envelopes and transfer of core material: a hypothesis." Virology **48**(2): 342-59.
- Chatterjee, P. K., M. Bruner, S. J. Flint and M. L. Harter (1988). "DNA-binding properties of an adenovirus 289R E1A protein." Embo J **7**(3): 835-41.
- Chinnadurai, G. (2002). "CtBP, an unconventional transcriptional corepressor in development and oncogenesis." Mol Cell **9**(2): 213-24.
- Chinnadurai, G. (2009). "The transcriptional corepressor CtBP: a foe of multiple tumor suppressors." Cancer Res **69**(3): 731-4.
- Chiou, S. K., L. Rao and E. White (1994). "Bcl-2 blocks p53-dependent apoptosis." Mol Cell Biol **14**(4): 2556-63.
- Chung, S. H., K. K. Frese, R. S. Weiss, B. V. Prasad and R. T. Javier (2007). "A new crucial protein interaction element that targets the adenovirus E4-ORF1 oncoprotein to membrane vesicles." J Virol **81**(9): 4787-97.
- Chung, S. H., R. S. Weiss, K. K. Frese, B. V. Prasad and R. T. Javier (2008). "Functionally distinct monomers and trimers produced by a viral oncoprotein." Oncogene **27**(10): 1412-20.
- Culp, J. S., L. C. Webster, D. J. Friedman, C. L. Smith, W. J. Huang, F. Y. Wu, M. Rosenberg and R. P. Ricciardi (1988). "The 289-amino acid E1A protein of adenovirus binds zinc in a region that is important for trans-activation." Proc Natl Acad Sci U S A **85**(17): 6450-4.
- Dales, S. and Y. Chardonnet (1973). "Early events in the interaction of adenoviruses with HeLa cells. IV. Association with microtubules and the nuclear pore complex during vectorial movement of the inoculum." Virology **56**(2): 465-83.
- De Luca, A., R. Mangiacasale, A. Severino, L. Malquori, A. Baldi, A. Palena, A. M. Mileo, P. Lavia and M. G. Paggi (2003). "E1A deregulates the centrosome cycle in a Ran GTPase-dependent manner." Cancer Res **63**(6): 1430-7.
- de Vetten, N., F. Quattrocchio, J. Mol and R. Koes (1997). "The an11 locus controlling flower pigmentation in petunia encodes a novel WD-repeat protein conserved in yeast, plants, and animals." Genes Dev **11**(11): 1422-34.

- Deng, X., D. Z. Ewton, S. Li, A. Naqvi, S. E. Mercer, S. Landas and E. Friedman (2006). "The kinase Mirk/Dyrk1B mediates cell survival in pancreatic ductal adenocarcinoma." Cancer Res **66**(8): 4149-58.
- Douglas, J. L., S. Gopalakrishnan and M. P. Quinlan (1991). "Modulation of transformation of primary epithelial cells by the second exon of the Ad5 E1A12S gene." Oncogene **6**(11): 2093-103.
- Douglas, J. L. and M. P. Quinlan (1994). "Efficient nuclear localization of the Ad5 E1A 12S protein is necessary for immortalization but not cotransformation of primary epithelial cells." Cell Growth Differ **5**(5): 475-83.
- Douglas, J. L. and M. P. Quinlan (1995). "Efficient nuclear localization and immortalizing ability, two functions dependent on the adenovirus type 5 (Ad5) E1A second exon, are necessary for cotransformation with Ad5 E1B but not with T24ras." J Virol **69**(12): 8061-5.
- Dunker, A. K., M. S. Cortese, P. Romero, L. M. Iakoucheva and V. N. Uversky (2005). "Flexible nets. The roles of intrinsic disorder in protein interaction networks." Febs J **272**(20): 5129-48.
- Eckner, R., M. E. Ewen, D. Newsome, M. Gerdes, J. A. DeCaprio, J. B. Lawrence and D. M. Livingston (1994). "Molecular cloning and functional analysis of the adenovirus E1A-associated 300-kD protein (p300) reveals a protein with properties of a transcriptional adaptor." Genes Dev **8**(8): 869-84.
- Egan, C., T. N. Jelsma, J. A. Howe, S. T. Bayley, B. Ferguson and P. E. Branton (1988). "Mapping of cellular protein-binding sites on the products of early-region 1A of human adenovirus type 5." Mol Cell Biol **8**(9): 3955-9.
- Elsing, A. and H. G. Burgert (1998). "The adenovirus E3/10.4K-14.5K proteins down-modulate the apoptosis receptor Fas/Apo-1 by inducing its internalization." Proc Natl Acad Sci U S A **95**(17): 10072-7.
- Farrow, S. N., J. H. White, I. Martinou, T. Raven, K. T. Pun, C. J. Grinham, J. C. Martinou and R. Brown (1995). "Cloning of a bcl-2 homologue by interaction with adenovirus E1B 19K." Nature **374**(6524): 731-3.
- Fattaey, A. R., E. Harlow and K. Helin (1993). "Independent regions of adenovirus E1A are required for binding to and dissociation of E2F-protein complexes." Mol Cell Biol **13**(12): 7267-77.
- Fax, P., C. R. Carlson, P. Collas, K. Tasken, H. Esche and D. Brockmann (2001). "Binding of PKA-RIIalpha to the Adenovirus E1A12S oncoprotein correlates with its nuclear translocation and an increase in PKA-dependent promoter activity." Virology **285**(1): 30-41.

- Ferrari, R., M. Pellegrini, G. A. Horwitz, W. Xie, A. J. Berk and S. K. Kurdistani (2008). "Epigenetic reprogramming by adenovirus e1a." Science **321**(5892): 1086-8.
- Ferreon, J. C., M. A. Martinez-Yamout, H. J. Dyson and P. E. Wright (2009). "Structural basis for subversion of cellular control mechanisms by the adenoviral E1A oncoprotein." Proc Natl Acad Sci U S A **106**(32): 13260-5.
- Flint, J. and T. Shenk (1997). "Viral transactivating proteins." Annu Rev Genet **31**: 177-212.
- Fonseca, G. J., M. J. Cohen and J. S. Mymryk (2014). "Adenovirus E1A recruits the human Paf1 complex to enhance transcriptional elongation." J Virol **88**(10): 5630-7.
- Fonseca, G. J., M. J. Cohen, A. C. Nichols, J. W. Barrett and J. S. Mymryk (2013). "Viral retasking of hBre1/RNF20 to recruit hPaf1 for transcriptional activation." PLoS Pathog **9**(6): e1003411.
- Fonseca, G. J., G. Thillainadesan, A. F. Yousef, J. N. Ablack, K. L. Mossman, J. Torchia and J. S. Mymryk (2012). "Adenovirus evasion of interferon-mediated innate immunity by direct antagonism of a cellular histone posttranslational modification." Cell Host Microbe **11**(6): 597-606.
- Freeman, A. E., P. H. Black, E. A. Vanderpool, P. H. Henry, J. B. Austin and R. J. Huebner (1967). "Transformation of primary rat embryo cells by adenovirus type 2." Proc Natl Acad Sci U S A **58**(3): 1205-12.
- Frese, K. K., S. S. Lee, D. L. Thomas, I. J. Latorre, R. S. Weiss, B. A. Glaunsinger and R. T. Javier (2003). "Selective PDZ protein-dependent stimulation of phosphatidylinositol 3-kinase by the adenovirus E4-ORF1 oncoprotein." Oncogene **22**(5): 710-21.
- Friedman, J. M. and M. S. Horwitz (2002). "Inhibition of tumor necrosis factor alpha-induced NF-kappa B activation by the adenovirus E3-10.4/14.5K complex." J Virol **76**(11): 5515-21.
- Frisch, S. M. and J. S. Mymryk (2002). "Adenovirus-5 E1A: paradox and paradigm." Nat Rev Mol Cell Biol **3**(6): 441-52.
- Gallimore, P. H. (1972). "Tumour production in immunosuppressed rats with cells transformed in vitro by adenovirus type 2." J Gen Virol **16**(1): 99-102.
- Gallimore, P. H. and A. S. Turnell (2001). "Adenovirus E1A: remodelling the host cell, a life or death experience." Oncogene **20**(54): 7824-35.
- Garner, E., P. Romero, A. K. Dunker, C. Brown and Z. Obradovic (1999). "Predicting Binding Regions within Disordered Proteins." Genome Inform Ser Workshop Genome Inform **10**: 41-50.

- Geisberg, J. V., W. S. Lee, A. J. Berk and R. P. Ricciardi (1994). "The zinc finger region of the adenovirus E1A transactivating domain complexes with the TATA box binding protein." Proc Natl Acad Sci U S A **91**(7): 2488-92.
- Ginsberg, H. S., H. G. Pereira, R. C. Valentine and W. C. Wilcox (1966). "A proposed terminology for the adenovirus antigens and virion morphological subunits." Virology **28**(4): 782-3.
- Glenn, G. M. and R. P. Ricciardi (1985). "Adenovirus 5 early region 1A host range mutants hr3, hr4, and hr5 contain point mutations which generate single amino acid substitutions." J Virol **56**(1): 66-74.
- Gonzalez, R., W. Huang, R. Finnen, C. Bragg and S. J. Flint (2006). "Adenovirus E1B 55-kilodalton protein is required for both regulation of mRNA export and efficient entry into the late phase of infection in normal human fibroblasts." J Virol **80**(2): 964-74.
- Gonzalez, R. A. and S. J. Flint (2002). "Effects of mutations in the adenoviral E1B 55-kilodalton protein coding sequence on viral late mRNA metabolism." J Virol **76**(9): 4507-19.
- Grooteclaes, M., Q. Deveraux, J. Hildebrand, Q. Zhang, R. H. Goodman and S. M. Frisch (2003). "C-terminal-binding protein corepresses epithelial and proapoptotic gene expression programs." Proc Natl Acad Sci U S A **100**(8): 4568-73.
- Guo, X., J. G. Williams, T. T. Schug and X. Li (2010). "DYRK1A and DYRK3 promote cell survival through phosphorylation and activation of SIRT1." J Biol Chem **285**(17): 13223-32.
- Halbert, D. N., J. R. Cutt and T. Shenk (1985). "Adenovirus early region 4 encodes functions required for efficient DNA replication, late gene expression, and host cell shutoff." J Virol **56**(1): 250-7.
- Hamada, F. and M. Bienz (2004). "The APC tumor suppressor binds to C-terminal binding protein to divert nuclear beta-catenin from TCF." Dev Cell **7**(5): 677-85.
- Harada, J. N., A. Shevchenko, A. Shevchenko, D. C. Pallas and A. J. Berk (2002). "Analysis of the adenovirus E1B-55K-anchored proteome reveals its link to ubiquitination machinery." J Virol **76**(18): 9194-206.
- Hateboer, G., A. Gennissen, Y. F. Ramos, R. M. Kerkhoven, V. Sonntag-Buck, H. G. Stunnenberg and R. Bernards (1995). "BS69, a novel adenovirus E1A-associated protein that inhibits E1A transactivation." Embo J **14**(13): 3159-69.
- Hawkins, L. K. and W. S. Wold (1992). "A 12,500 MW protein is coded by region E3 of adenovirus." Virology **188**(2): 486-94.

- Hilleman, M. R. and J. H. Werner (1954). "Recovery of new agent from patients with acute respiratory illness." Proc Soc Exp Biol Med **85**(1): 183-8.
- Hori, S., T. Nomura and S. Sakaguchi (2003). "Control of regulatory T cell development by the transcription factor Foxp3." Science **299**(5609): 1057-61.
- Horwitz, G. A., K. Zhang, M. A. McBrian, M. Grunstein, S. K. Kurdistani and A. J. Berk (2008). "Adenovirus small e1a alters global patterns of histone modification." Science **321**(5892): 1084-5.
- Houweling, A., P. J. van den Elsen and A. J. van der Eb (1980). "Partial transformation of primary rat cells by the leftmost 4.5% fragment of adenovirus 5 DNA." Virology **105**(2): 537-50.
- Huang, M. M. and P. Hearing (1989). "The adenovirus early region 4 open reading frame 6/7 protein regulates the DNA binding activity of the cellular transcription factor, E2F, through a direct complex." Genes Dev **3**(11): 1699-710.
- Hughes-Davies, L., D. Huntsman, M. Ruas, F. Fuks, J. Bye, S. F. Chin, J. Milner, L. A. Brown, F. Hsu, B. Gilks, T. Nielsen, M. Schulzer, S. Chia, J. Ragaz, A. Cahn, L. Linger, H. Ozdag, E. Cattaneo, E. S. Jordanova, E. Schuurin, D. S. Yu, A. Venkitaraman, B. Ponder, A. Doherty, S. Aparicio, D. Bentley, C. Theillet, C. P. Ponting, C. Caldas and T. Kouzarides (2003). "EMSY links the BRCA2 pathway to sporadic breast and ovarian cancer." Cell **115**(5): 523-35.
- Ikeda, M. A. and J. R. Nevins (1993). "Identification of distinct roles for separate E1A domains in disruption of E2F complexes." Mol Cell Biol **13**(11): 7029-35.
- Isobe, T., C. Uchida, T. Hattori, K. Kitagawa, T. Oda and M. Kitagawa (2006). "Ubiquitin-dependent degradation of adenovirus E1A protein is inhibited by BS69." Biochem Biophys Res Commun **339**(1): 367-74.
- Jin, K., S. Park, D. Z. Ewton and E. Friedman (2007). "The survival kinase Mirk/Dyrk1B is a downstream effector of oncogenic K-ras in pancreatic cancer." Cancer Res **67**(15): 7247-55.
- Jones, N. and T. Shenk (1979). "An adenovirus type 5 early gene function regulates expression of other early viral genes." Proc Natl Acad Sci U S A **76**(8): 3665-9.
- Karen, K. A., P. J. Hoey, C. S. Young and P. Hearing (2009). "Temporal regulation of the Mre11-Rad50-Nbs1 complex during adenovirus infection." J Virol **83**(9): 4565-73.
- Kelly, T. J., Jr. and R. L. Lechner (1979). "The structure of replicating adenovirus DNA molecules: characterization of DNA-protein complexes from infected cells." Cold Spring Harb Symp Quant Biol **43 Pt 2**: 721-8.

- Kim, P. M., A. Sboner, Y. Xia and M. Gerstein (2008). "The role of disorder in interaction networks: a structural analysis." Mol Syst Biol **4**: 179.
- Kimelman, D., J. S. Miller, D. Porter and B. E. Roberts (1985). "E1a regions of the human adenoviruses and of the highly oncogenic simian adenovirus 7 are closely related." J Virol **53**(2): 399-409.
- Klingseisen, L., M. Ehrenschwender, U. Heigl, H. Wajant, T. Hehlhans, S. Schutze and W. Schneider-Brachert (2012). "E3-14.7K is recruited to TNF-receptor 1 and blocks TNF cytolysis independent from interaction with optineurin." PLoS One **7**(6): e38348.
- Kohler, M., D. Gorlich, E. Hartmann and J. Franke (2001). "Adenoviral E1A protein nuclear import is preferentially mediated by importin alpha3 in vitro." Virology **289**(2): 186-91.
- Komorek, J., M. Kuppuswamy, T. Subramanian, S. Vijayalingam, E. Lomonosova, L. J. Zhao, J. S. Mymryk, K. Schmitt and G. Chinnadurai (2010). "Adenovirus type 5 E1A and E6 proteins of low-risk cutaneous beta-human papillomaviruses suppress cell transformation through interaction with FOXP1/K2 transcription factors." J Virol **84**(6): 2719-31.
- Korner, H. and H. G. Burgert (1994). "Down-regulation of HLA antigens by the adenovirus type 2 E3/19K protein in a T-lymphoma cell line." J Virol **68**(3): 1442-8.
- Krajcsi, P., T. Dimitrov, T. W. Hermiston, A. E. Tollefson, T. S. Ranheim, S. B. Vande Pol, A. H. Stephenson and W. S. Wold (1996). "The adenovirus E3-14.7K protein and the E3-10.4K/14.5K complex of proteins, which independently inhibit tumor necrosis factor (TNF)-induced apoptosis, also independently inhibit TNF-induced release of arachidonic acid." J Virol **70**(8): 4904-13.
- Laguna, A., S. Aranda, M. J. Barallobre, R. Barhoum, E. Fernandez, V. Fotaki, J. M. Delabar, S. de la Luna, P. de la Villa and M. L. Arbones (2008). "The protein kinase DYRK1A regulates caspase-9-mediated apoptosis during retina development." Dev Cell **15**(6): 841-53.
- Lee, K., X. Deng and E. Friedman (2000). "Mirk protein kinase is a mitogen-activated protein kinase substrate that mediates survival of colon cancer cells." Cancer Res **60**(13): 3631-7.
- Levine, A. J., P. C. van der Vliet, B. Rosenwirth, C. Anderson, J. Rabek, A. Levinson and S. Anderson (1976). "Characterization of an adenovirus early protein required for viral DNA replication: a single strand specific DNA binding proteins." Mol Cell Biochem **11**(2): 79-95.
- Lillie, J. W., M. Green and M. R. Green (1986). "An adenovirus E1a protein region required for transformation and transcriptional repression." Cell **46**(7): 1043-51.

- Liu, X. and R. Marmorstein (2007). "Structure of the retinoblastoma protein bound to adenovirus E1A reveals the molecular basis for viral oncoprotein inactivation of a tumor suppressor." Genes Dev **21**(21): 2711-6.
- Lonberg-Holm, K. and L. Philipson (1969). "Early events of virus-cell interaction in an adenovirus system." J Virol **4**(4): 323-38.
- Lyons, R. H., B. Q. Ferguson and M. Rosenberg (1987). "Pentapeptide nuclear localization signal in adenovirus E1a." Mol Cell Biol **7**(7): 2451-6.
- Madison, D. L., P. Yaciuk, R. P. Kwok and J. R. Lundblad (2002). "Acetylation of the adenovirus-transforming protein E1A determines nuclear localization by disrupting association with importin-alpha." J Biol Chem **277**(41): 38755-63.
- Marais, A., Z. Ji, E. S. Child, E. Krause, D. J. Mann and A. D. Sharrocks (2010). "Cell cycle-dependent regulation of the forkhead transcription factor FOXK2 by CDK.cyclin complexes." J Biol Chem **285**(46): 35728-39.
- Masselink, H. and R. Bernards (2000). "The adenovirus E1A binding protein BS69 is a corepressor of transcription through recruitment of N-CoR." Oncogene **19**(12): 1538-46.
- McBride, W. D. and A. Wiener (1964). "In Vitro Transformation of Hamster Kidney Cells by Human Adenovirus Type 12." Proc Soc Exp Biol Med **115**: 870-4.
- Meier, O. and U. F. Greber (2004). "Adenovirus endocytosis." J Gene Med **6 Suppl 1**: S152-63.
- Mellman, I. (1992). "The importance of being acid: the role of acidification in intracellular membrane traffic." J Exp Biol **172**: 39-45.
- Meng, X., Y. F. Yang, X. Cao, M. V. Govindan, M. Shuen, A. N. Hollenberg, J. S. Mymryk and P. G. Walfish (2003). "Cellular context of coregulator and adaptor proteins regulates human adenovirus 5 early region 1A-dependent gene activation by the thyroid hormone receptor." Mol Endocrinol **17**(6): 1095-105.
- Mercer, S. E., D. Z. Ewton, X. Deng, S. Lim, T. R. Mazur and E. Friedman (2005). "Mirk/Dyrk1B mediates survival during the differentiation of C2C12 myoblasts." J Biol Chem **280**(27): 25788-801.
- Miller, M. S., P. Pelka, G. J. Fonseca, M. J. Cohen, J. N. Kelly, S. D. Barr, R. J. Grand, A. S. Turnell, P. Whyte and J. S. Mymryk (2012). "Characterization of the 55-residue protein encoded by the 9S E1A mRNA of species C adenovirus." J Virol **86**(8): 4222-33.
- Moise, A. R., J. R. Grant, T. Z. Vitalis and W. A. Jefferies (2002). "Adenovirus E3-6.7K maintains calcium homeostasis and prevents apoptosis and arachidonic acid release." J Virol **76**(4): 1578-87.

- Moller, R. S., S. Kubart, M. Hoeltzenbein, B. Heye, I. Vogel, C. P. Hansen, C. Menzel, R. Ullmann, N. Tommerup, H. H. Ropers, Z. Tumer and V. M. Kalscheuer (2008). "Truncation of the Down syndrome candidate gene DYRK1A in two unrelated patients with microcephaly." Am J Hum Genet **82**(5): 1165-70.
- Moran, E., B. Zerler, T. M. Harrison and M. B. Mathews (1986). "Identification of separate domains in the adenovirus E1A gene for immortalization activity and the activation of virus early genes." Mol Cell Biol **6**(10): 3470-80.
- Morita, K., C. Lo Celso, B. Spencer-Dene, C. C. Zouboulis and F. M. Watt (2006). "HAN11 binds mDia1 and controls GII1 transcriptional activity." J Dermatol Sci **44**(1): 11-20.
- Morris, E. J. and N. J. Dyson (2001). "Retinoblastoma protein partners." Adv Cancer Res **82**: 1-54.
- Muller, S. and T. Dobner (2008). "The adenovirus E1B-55K oncoprotein induces SUMO modification of p53." Cell Cycle **7**(6): 754-8.
- Nevins, J. R., H. S. Ginsberg, J. M. Blanchard, M. C. Wilson and J. E. Darnell, Jr. (1979). "Regulation of the primary expression of the early adenovirus transcription units." J Virol **32**(3): 727-33.
- Norrby, E. (1966). "The relationship between the soluble antigens and the virion of adenovirus type 3. II. Identification and characterization of an incomplete hemagglutinin." Virology **30**(4): 608-17.
- Norrby, E. and P. Skaaret (1967). "The relationship between soluble antigens and the virion of adenovirus type 3. 3. Immunological identification of fiber antigen and isolated vertex capsomer antigen." Virology **32**(3): 489-502.
- O'Connor, M. J., H. Zimmermann, S. Nielsen, H. U. Bernard and T. Kouzarides (1999). "Characterization of an E1A-CBP interaction defines a novel transcriptional adapter motif (TRAM) in CBP/p300." J Virol **73**(5): 3574-81.
- O'Shea, C., K. Klupsch, S. Choi, B. Bagus, C. Soria, J. Shen, F. McCormick and D. Stokoe (2005). "Adenoviral proteins mimic nutrient/growth signals to activate the mTOR pathway for viral replication." Embo J **24**(6): 1211-21.
- Park, J., W. J. Song and K. C. Chung (2009). "Function and regulation of Dyrk1A: towards understanding Down syndrome." Cell Mol Life Sci **66**(20): 3235-40.
- Peinado, H., D. Olmeda and A. Cano (2007). "Snail, Zeb and bHLH factors in tumour progression: an alliance against the epithelial phenotype?" Nat Rev Cancer **7**(6): 415-28.

- Pelka, P., J. N. Ablack, G. J. Fonseca, A. F. Yousef and J. S. Mymryk (2008). "Intrinsic structural disorder in adenovirus E1A: a viral molecular hub linking multiple diverse processes." *J Virol* **82**(15): 7252-63.
- Pelka, P., J. N. Ablack, M. Shuen, A. F. Yousef, M. Rasti, R. J. Grand, A. S. Turnell and J. S. Mymryk (2009). "Identification of a second independent binding site for the pCAF acetyltransferase in adenovirus E1A." *Virology* **391**(1): 90-8.
- Pelka, P., A. Scime, C. Mandalfino, M. Joch, P. Abdulla and P. Whyte (2007). "Adenovirus E1A proteins direct subcellular redistribution of Nek9, a NimA-related kinase." *J Cell Physiol* **212**(1): 13-25.
- Pennella, M. A., Y. Liu, J. L. Woo, C. A. Kim and A. J. Berk (2010). "Adenovirus E1B 55-kilodalton protein is a p53-SUMO1 E3 ligase that represses p53 and stimulates its nuclear export through interactions with promyelocytic leukemia nuclear bodies." *J Virol* **84**(23): 12210-25.
- Postigo, A. A. and D. C. Dean (1999). "ZEB represses transcription through interaction with the corepressor CtBP." *Proc Natl Acad Sci U S A* **96**(12): 6683-8.
- Querido, E., P. Blanchette, Q. Yan, T. Kamura, M. Morrison, D. Boivin, W. G. Kaelin, R. C. Conaway, J. W. Conaway and P. E. Branton (2001). "Degradation of p53 by adenovirus E4orf6 and E1B55K proteins occurs via a novel mechanism involving a Cullin-containing complex." *Genes Dev* **15**(23): 3104-17.
- Quinlan, M. P. and J. L. Douglas (1992). "Immortalization of primary epithelial cells requires first- and second-exon functions of adenovirus type 5 12S." *J Virol* **66**(4): 2020-30.
- Quinlan, M. P., P. Whyte and T. Grodzicker (1988). "Growth factor induction by the adenovirus type 5 E1A 12S protein is required for immortalization of primary epithelial cells." *Mol Cell Biol* **8**(8): 3191-203.
- Rao, L., M. Debbas, P. Sabbatini, D. Hockenbery, S. Korsmeyer and E. White (1992). "The adenovirus E1A proteins induce apoptosis, which is inhibited by the E1B 19-kDa and Bcl-2 proteins." *Proc Natl Acad Sci U S A* **89**(16): 7742-6.
- Rasti, M., R. J. Grand, A. F. Yousef, M. Shuen, J. S. Mymryk, P. H. Gallimore and A. S. Turnell (2006). "Roles for APIS and the 20S proteasome in adenovirus E1A-dependent transcription." *Embo J* **25**(12): 2710-22.
- Rekosh, D. M., W. C. Russell, A. J. Bellet and A. J. Robinson (1977). "Identification of a protein linked to the ends of adenovirus DNA." *Cell* **11**(2): 283-95.
- Ritterhoff, S., C. M. Farah, J. Grabitzki, G. Lochnit, A. V. Skurat and M. L. Schmitz (2010). "The WD40-repeat protein Han11 functions as a scaffold protein to control HIPK2 and MEKK1 kinase functions." *Embo J* **29**(22): 3750-61.

- Romero, P., Z. Obradovic, X. Li, E. C. Garner, C. J. Brown and A. K. Dunker (2001). "Sequence complexity of disordered protein." *Proteins* **42**(1): 38-48.
- Rowe, W. P., R. J. Huebner, L. K. Gilmore, R. H. Parrott and T. G. Ward (1953). "Isolation of a cytopathogenic agent from human adenoids undergoing spontaneous degeneration in tissue culture." *Proc Soc Exp Biol Med* **84**(3): 570-3.
- Rozenblatt-Rosen, O., R. C. Deo, M. Padi, G. Adelmant, M. A. Calderwood, T. Rolland, M. Grace, A. Dricot, M. Askenazi, M. Tavares, S. J. Pevzner, F. Abderazzaq, D. Byrdson, A. R. Carvunis, A. A. Chen, J. Cheng, M. Correll, M. Duarte, C. Fan, M. C. Feltkamp, S. B. Ficarro, R. Franchi, B. K. Garg, N. Gulbahce, T. Hao, A. M. Holthaus, R. James, A. Korkhin, L. Litovchick, J. C. Mar, T. R. Pak, S. Rabello, R. Rubio, Y. Shen, S. Singh, J. M. Spangle, M. Tasan, S. Wanamaker, J. T. Webber, J. Roeklein-Canfield, E. Johannsen, A. L. Barabasi, R. Beroukhim, E. Kieff, M. E. Cusick, D. E. Hill, K. Munger, J. A. Marto, J. Quackenbush, F. P. Roth, J. A. DeCaprio and M. Vidal (2012). "Interpreting cancer genomes using systematic host network perturbations by tumour virus proteins." *Nature* **487**(7408): 491-5.
- Ruley, H. E. (1983). "Adenovirus early region 1A enables viral and cellular transforming genes to transform primary cells in culture." *Nature* **304**(5927): 602-6.
- Schaeper, U., J. M. Boyd, S. Verma, E. Uhlmann, T. Subramanian and G. Chinnadurai (1995). "Molecular cloning and characterization of a cellular phosphoprotein that interacts with a conserved C-terminal domain of adenovirus E1A involved in negative modulation of oncogenic transformation." *Proc Natl Acad Sci U S A* **92**(23): 10467-71.
- Seifert, A., L. A. Allan and P. R. Clarke (2008). "DYRK1A phosphorylates caspase 9 at an inhibitory site and is potently inhibited in human cells by harmine." *Febs J* **275**(24): 6268-80.
- Shi, X., K. M. Bowlin and D. J. Garry (2010). "Fhl2 interacts with Foxk1 and corepresses Foxo4 activity in myogenic progenitors." *Stem Cells* **28**(3): 462-9.
- Shisler, J., C. Yang, B. Walter, C. F. Ware and L. R. Gooding (1997). "The adenovirus E3-10.4K/14.5K complex mediates loss of cell surface Fas (CD95) and resistance to Fas-induced apoptosis." *J Virol* **71**(11): 8299-306.
- Sierra, J., T. Yoshida, C. A. Joazeiro and K. A. Jones (2006). "The APC tumor suppressor counteracts beta-catenin activation and H3K4 methylation at Wnt target genes." *Genes Dev* **20**(5): 586-600.
- Skurat, A. V. and A. D. Dietrich (2004). "Phosphorylation of Ser640 in muscle glycogen synthase by DYRK family protein kinases." *J Biol Chem* **279**(4): 2490-8.

- Sohn, S. Y. and P. Hearing (2012). "Adenovirus regulates sumoylation of Mre11-Rad50-Nbs1 components through a paralog-specific mechanism." J Virol **86**(18): 9656-65.
- Somasundaram, K., G. Jayaraman, T. Williams, E. Moran, S. Frisch and B. Thimmapaya (1996). "Repression of a matrix metalloprotease gene by E1A correlates with its ability to bind to cell type-specific transcription factor AP-2." Proc Natl Acad Sci U S A **93**(7): 3088-93.
- Steenbergh, P. H., J. Maat, H. van Ormondt and J. S. Sussenbach (1977). "The nucleotide sequence at the termini of adenovirus type 5 DNA." Nucleic Acids Res **4**(12): 4371-89.
- Stein, R. W., M. Corrigan, P. Yaciuk, J. Whelan and E. Moran (1990). "Analysis of E1A-mediated growth regulation functions: binding of the 300-kilodalton cellular product correlates with E1A enhancer repression function and DNA synthesis-inducing activity." J Virol **64**(9): 4421-7.
- Stephens, C. and E. Harlow (1987). "Differential splicing yields novel adenovirus 5 E1A mRNAs that encode 30 kd and 35 kd proteins." Embo J **6**(7): 2027-35.
- Stracker, T. H., C. T. Carson and M. D. Weitzman (2002). "Adenovirus oncoproteins inactivate the Mre11-Rad50-NBS1 DNA repair complex." Nature **418**(6895): 348-52.
- Strom, A. C., P. Ohlsson and G. Akusjarvi (1998). "AR1 is an integral part of the adenovirus type 2 E1A-CR3 transactivation domain." J Virol **72**(7): 5978-83.
- Subramanian, T., M. La Regina and G. Chinnadurai (1989). "Enhanced ras oncogene mediated cell transformation and tumorigenesis by adenovirus 2 mutants lacking the C-terminal region of E1a protein." Oncogene **4**(4): 415-20.
- Subramanian, T., S. E. Malstrom and G. Chinnadurai (1991). "Requirement of the C-terminal region of adenovirus E1a for cell transformation in cooperation with E1b." Oncogene **6**(7): 1171-3.
- Tollefson, A. E., T. W. Hermiston, D. L. Lichtenstein, C. F. Colle, R. A. Tripp, T. Dimitrov, K. Toth, C. E. Wells, P. C. Doherty and W. S. Wold (1998). "Forced degradation of Fas inhibits apoptosis in adenovirus-infected cells." Nature **392**(6677): 726-30.
- Tollefson, A. E., J. S. Ryerse, A. Scaria, T. W. Hermiston and W. S. Wold (1996). "The E3-11.6-kDa adenovirus death protein (ADP) is required for efficient cell death: characterization of cells infected with adp mutants." Virology **220**(1): 152-62.
- Tollefson, A. E., A. Scaria, S. K. Saha and W. S. Wold (1992). "The 11,600-MW protein encoded by region E3 of adenovirus is expressed early but is greatly amplified at late stages of infection." J Virol **66**(6): 3633-42.

- Tollefson, A. E., K. Toth, K. Doronin, M. Kuppaswamy, O. A. Doronina, D. L. Lichtenstein, T. W. Hermiston, C. A. Smith and W. S. Wold (2001). "Inhibition of TRAIL-induced apoptosis and forced internalization of TRAIL receptor 1 by adenovirus proteins." *J Virol* **75**(19): 8875-87.
- Tollefson, A. E., B. Ying, K. Doronin, P. D. Sidor and W. S. Wold (2007). "Identification of a new human adenovirus protein encoded by a novel late 1-strand transcription unit." *J Virol* **81**(23): 12918-26.
- Trentin, J. J., Y. Yabe and G. Taylor (1962). "The quest for human cancer viruses." *Science* **137**: 835-41.
- Turnell, A. S., R. J. Grand, C. Gorbea, X. Zhang, W. Wang, J. S. Mymryk and P. H. Gallimore (2000). "Regulation of the 26S proteasome by adenovirus E1A." *Embo J* **19**(17): 4759-73.
- Ulfendahl, P. J., S. Linder, J. P. Kreivi, K. Nordqvist, C. Sevensson, H. Hultberg and G. Akusjarvi (1987). "A novel adenovirus-2 E1A mRNA encoding a protein with transcription activation properties." *Embo J* **6**(7): 2037-44.
- Ullman, A. J., N. C. Reich and P. Hearing (2007). "Adenovirus E4 ORF3 protein inhibits the interferon-mediated antiviral response." *J Virol* **81**(9): 4744-52.
- van Breukelen, B., A. B. Brenkman, P. E. Holthuizen and P. C. van der Vliet (2003). "Adenovirus type 5 DNA binding protein stimulates binding of DNA polymerase to the replication origin." *J Virol* **77**(2): 915-22.
- van der Vliet, P. C. and A. J. Levine (1973). "DNA-binding proteins specific for cells infected by adenovirus." *Nat New Biol* **246**(154): 170-4.
- van Ormondt, H. and B. Hesper (1983). "Comparison of the nucleotide sequences of early region E1b DNA of human adenovirus types 12, 7 and 5 (subgroups A, B and C)." *Gene* **21**(3): 217-26.
- Varga, M. J., C. Weibull and E. Everitt (1991). "Infectious entry pathway of adenovirus type 2." *J Virol* **65**(11): 6061-70.
- Wan, J., W. Zhang, L. Wu, T. Bai, M. Zhang, K. W. Lo, Y. L. Chui, Y. Cui, Q. Tao, M. Yamamoto, S. Akira and Z. Wu (2006). "BS69, a specific adaptor in the latent membrane protein 1-mediated c-Jun N-terminal kinase pathway." *Mol Cell Biol* **26**(2): 448-56.
- Webster, L. C. and R. P. Ricciardi (1991). "trans-dominant mutants of E1A provide genetic evidence that the zinc finger of the trans-activating domain binds a transcription factor." *Mol Cell Biol* **11**(9): 4287-96.
- Weitzman, M. D. and D. A. Ornelles (2005). "Inactivating intracellular antiviral responses during adenovirus infection." *Oncogene* **24**(52): 7686-96.

- Whittaker, J. L., P. J. Byrd, R. J. Grand and P. H. Gallimore (1984). "Isolation and characterization of four adenovirus type 12-transformed human embryo kidney cell lines." Mol Cell Biol **4**(1): 110-6.
- Whyte, P., K. J. Buchkovich, J. M. Horowitz, S. H. Friend, M. Raybuck, R. A. Weinberg and E. Harlow (1988). "Association between an oncogene and an anti-oncogene: the adenovirus E1A proteins bind to the retinoblastoma gene product." Nature **334**(6178): 124-9.
- Wickham, T. J., M. E. Carrion and I. Kovesdi (1995). "Targeting of adenovirus penton base to new receptors through replacement of its RGD motif with other receptor-specific peptide motifs." Gene Ther **2**(10): 750-6.
- Wickham, T. J., P. Mathias, D. A. Cheresh and G. R. Nemerow (1993). "Integrins alpha v beta 3 and alpha v beta 5 promote adenovirus internalization but not virus attachment." Cell **73**(2): 309-19.
- Williams, J., T. Grodzicker, P. Sharp and J. Sambrook (1975). "Adenovirus recombination: physical mapping of crossover events." Cell **4**(2): 113-9.
- Wold, W. S. and M. G. Ison (2013). Adenoviruses. (Philadelphia: Lippincot - Raven), Philadelphia: Wolters Kluwer Health/Lippincott Williams & Wilkins.
- Wong, H. K. and E. B. Ziff (1994). "Complementary functions of E1a conserved region 1 cooperate with conserved region 3 to activate adenovirus serotype 5 early promoters." J Virol **68**(8): 4910-20.
- Yatherajam, G., W. Huang and S. J. Flint (2011). "Export of adenoviral late mRNA from the nucleus requires the Nxf1/Tap export receptor." J Virol **85**(4): 1429-38.
- Yew, P. R. and A. J. Berk (1992). "Inhibition of p53 transactivation required for transformation by adenovirus early 1B protein." Nature **357**(6373): 82-5.
- Yousef, A. F., G. J. Fonseca, P. Pelka, J. N. Ablack, C. Walsh, F. A. Dick, D. P. Bazett-Jones, G. S. Shaw and J. S. Mymryk (2010). "Identification of a molecular recognition feature in the E1A oncoprotein that binds the SUMO conjugase UBC9 and likely interferes with polySUMOylation." Oncogene **29**(33): 4693-704.
- Yousef, A. F., G. J. Fonseca, P. Pelka, J. N. Ablack, C. Walsh, F. A. Dick, D. P. Bazett-Jones, G. S. Shaw and J. S. Mymryk (2012). "Identification of a molecular recognition feature in the E1A oncoprotein that binds the SUMO conjugase UBC9 and likely interferes with polySUMOylation." Oncogene **29**(33): 4693-704.
- Zhang, Q., Y. Yoshimatsu, J. Hildebrand, S. M. Frisch and R. H. Goodman (2003). "Homeodomain interacting protein kinase 2 promotes apoptosis by downregulating the transcriptional corepressor CtBP." Cell **115**(2): 177-86.

- Zhang, W., H. M. Chan, Y. Gao, R. Poon and Z. Wu (2007). "BS69 is involved in cellular senescence through the p53-p21Cip1 pathway." EMBO Rep **8**(10): 952-8.
- Zhang, X., A. S. Turnell, C. Gorbea, J. S. Mymryk, P. H. Gallimore and R. J. Grand (2004). "The targeting of the proteasomal regulatory subunit S2 by adenovirus E1A causes inhibition of proteasomal activity and increased p53 expression." J Biol Chem **279**(24): 25122-33.
- Zhang, Z., M. M. Smith and J. S. Mymryk (2001). "Interaction of the E1A oncoprotein with Yak1p, a novel regulator of yeast pseudohyphal differentiation, and related mammalian kinases." Mol Biol Cell **12**(3): 699-710.
- Zu, Y. L., Y. Takamatsu, M. J. Zhao, T. Maekawa, H. Handa and S. Ishii (1992). "Transcriptional regulation by a point mutant of adenovirus-2 E1a product lacking DNA binding activity." J Biol Chem **267**(28): 20181-7.

Chapter 2

2 Dissection of the C-terminal region of E1A re-defines the roles of CtBP and other cellular targets in oncogenic transformation

2.1 Introduction

E1A is the first viral protein to be expressed following adenovirus infection (Pelka et al. 2008). One of its primary functions is to alter cellular gene expression to force quiescent cells to enter the cell cycle, thereby effectively reprogramming the infected cell to provide an optimal environment for viral replication (Bayley and Mymryk 1994; Flint and Shenk 1997). Early in infection, the E1A transcript is spliced to form two major mRNA species: the 13S and 12S mRNAs encoding 289 and 243 amino acid proteins respectively in HAdV 5. These two proteins are identical except for a 46 amino acid sequence within the first exon that is unique to the larger protein.

E1A is a viral oncoprotein. Alone, it is sufficient to immortalize primary rodent cells and is capable of fully transforming rodent cells in cooperation with HAdV E1B or activated Ras (Bayley and Mymryk 1994; Gallimore and Turnell 2001). Unlike many other oncoproteins, however, E1A displays no enzymatic or specific DNA binding capability (Avvakumov et al. 2002). Instead, E1A contains many SLIMs) which confer interaction with a plethora of cellular regulatory proteins. The interaction of E1A with these key targets alters or inhibits their function to deregulate gene expression and cell growth (Pelka et al. 2008). Comparisons of the sequences of the largest E1A proteins from different adenovirus types identified four regions of high conservation termed CR 1 through 4 (Figure 2.1). The evolutionary preservation of the highly conserved sequences within the CRs tends to support the concept that each CR has specific cellular binding partners and modulates their activity in a way that is critical for infection (Avvakumov et al. 2004; Pelka et al. 2008).

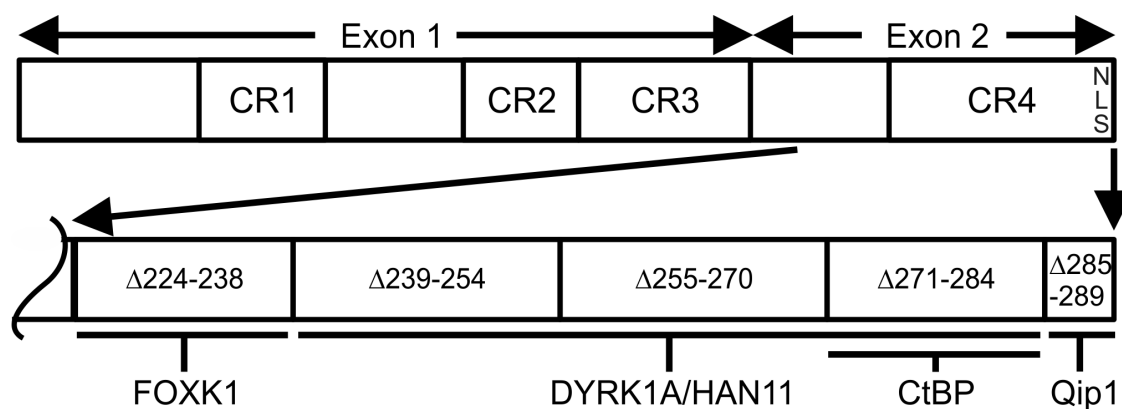

Figure 2.1 E1A conserved regions and location of known C-terminal target proteins

Amino acid sequence alignment of the E1A proteins from different HAdV species reveals four regions of conservation (CR1 through CR4). The second exon of E1A encodes 104 amino acids and contains the entirety of CR4. The known binding partners of this region include FOXK1/2, DYRK1A/B, HAN11, CtBP1/2 and Qip1. Note that the FOXK1/2 binding region is outside of CR4 and is present in a region unique to HAdV Species C. A map of previously characterized E1A deletion mutants is illustrated. Indicated residue numbers are based on the 289R protein. Note that dl1135, which deletes residues 271-284 of E1A, disrupts the binding site for DYRK1A/1B, HAN11 and CtBP.

Despite extensive study of E1A, relatively little is known about the function and cellular targets of the region encoded by the second exon of E1A, which contains CR4 (Avvakumov et al. 2004; Pelka et al. 2008). While E1A is remarkable in that it interacts with over 50 known proteins (Pelka et al. 2008), only four binding partners have been identified for CR4, which spans residues 240-288 of HAdV5 E1A (Avvakumov et al. 2004) (Figure 2.1). The first E1A CR4 binding partner, and hence the best characterized, are the transcriptional co-repressors CtBP 1 and 2. CtBP was originally discovered as an E1A interacting protein and acquired its name because it binds to the C-terminus of E1A (Schaeper et al. 1995). Interaction of CtBP with HAdV5 E1A requires the PLDLS SLIM, and this sequence, or closely related variants, is present in all known E1A sequences as well as many cellular proteins that interact with CtBP. Recently the FKH transcription factors FOXK1 and FOXK2 were identified as novel targets of the exon 2 encoded region of E1A (Komorek et al. 2010). The interaction of these transcription factors with E1A occurs outside of CR4 and requires residue S219, which must be phosphorylated for binding. CR4 of E1A also targets the DYRK proteins 1A and 1B, as well as the DYRK1A cofactor HAN11 (Zhang et al. 2001; Komorek et al. 2010). Finally, E1A interacts with importin- α 3 (also known as Qip1) through a canonical monopartite NLS located at the C-terminus (Lyons et al. 1987; Kohler et al. 2001).

Importantly, CR4 is required for transformation of primary rodent cells in combination with E1B (Subramanian et al. 1991; Douglas and Quinlan 1995). This activity requires both an efficient nuclear localization mediated by the NLS in CR4, as well as other regions in CR4 required for immortalization (Douglas and Quinlan 1995). In contrast, this region is not required for transformation in cooperation with activated Ras. Indeed, E1A mutants lacking the entire exon 2 encoded regions exhibit a hypertransforming phenotype (Subramanian et al. 1989). Thus, paradoxically, the C-terminal portion of E1A antagonizes Ras mediated transformation, yet is essential for transformation in cooperation with E1B. Both of these effects have previously been reported to be dependent on the ability of E1A to bind CtBP (Subramanian et al. 1989; Subramanian et al. 1991; Schaeper et al. 1995). More recently, the FOXK1/K2 interaction was shown to also play a role in the suppression of transformation in cooperation with activated Ras (Komorek et al. 2010). However, at least one other factor is necessary for this activity, as

there are CR4 mutants that retain CtBP and FOXK1 binding but fail to transform with E1B or suppress Ras transformation (Boyd et al. 1993). Furthermore, many of these mutants contain deletions in the recently identified DYRK1A and HAN11 binding region (Komorek et al. 2010), suggesting that DYRK1A and HAN11 may be the missing factors involved in E1A modulation of transformation (Figure 2.1). Given the recent identification of new cellular targets of E1A, the mapping of the DYRK1A and HAN11 binding region (Komorek et al. 2010), and previous work suggesting that subcellular localization of E1A may be important (Douglas and Quinlan 1994; Douglas and Quinlan 1995), we sought to re-evaluate and further characterize the mechanism by which the C-terminus of E1A functions. In the present study, we systematically mutated highly conserved residues within CR4 and evaluated their ability to bind all known CR4 targets. This was compared to their ability to transform in cooperation with E1B-55K or suppress transformation with activated Ras. These experiments suggest that interactions with importin- α 3/Qip1, DYRK1A and HAN11 aid E1A in its ability to induce oncogenic transformation in cooperation with E1B-55K. Furthermore, in agreement with the current model of E1A function, CtBP binding is also required for this effect. However, contrary to previous reports, we find that CtBP binding is not necessary for the suppression of Ras dependent transformation. Finally, we show that the interaction of CR4 with other cellular targets, such as DYRKs, is likely responsible for antagonizing Ras function.

2.2 Materials and Methods

2.2.1 Cell lines, cell culture and transfections

HT-1080 and HeLa cells were grown at 37°C with 5% CO₂ in Dulbecco's modified Eagle's medium (DMEM) supplemented with 10% fetal bovine serum (FBS). BRK cells and hooded lister rat embryo fibroblasts (HLREF) were cultured as described previously (Massimi and Banks 2005; Turnell et al. 2005). Plasmids were transfected into HT-1080 and HeLa cells using XtremeGeneHP (Roche) and used for experimentation 24 hours later.

2.2.2 Plasmids

All E1As were expressed as fusions with EGFP at the N-terminus, except for the transformation assays, which were untagged. HAdV5 E1A point mutants were constructed using two-step PCR. pcDNA3 HA-DYRK1A was described previously (Kentrup et al. 1996). HAN11 (Openbiosystems) was expressed as an HA-epitope located at the N-terminus. Qip1 was expressed as a fusion with the FLAG epitope located at the C-terminus (Nishinaka et al. 2004). E1A Δ 111-123 (Jelsma et al. 1988), E1A Δ 227-239 (Boyd et al. 1993), E1A Δ 256-273 (Douglas et al. 1991), and E1A Δ 285-289 (Boyd et al. 1993), were described previously. A list of primers used in this chapter is detailed in Table 2.1.

2.2.3 Western blotting and co-immunoprecipitation

Cells were lysed with nonidet-P40 NP40 lysis buffer and protein concentrations were determined with BioRad protein assay reagent using bovine serum albumin (BSA) as a standard. 0.5mg of protein lysate was immunoprecipitated with the indicated antibodies at 4°C for 4 hours. 10 μ g of protein was kept as 2% input. After 3 washes in NP40 lysis buffer, complexes were boiled in 25 μ L of sample buffer (Life Technologies) for 5 min. Proteins were separated on NuPage 4-12% Bis-Tris gradient gels (Life Technologies) and transferred onto a polyvinylidene difluoride (PVDF) membrane (GE Life Sciences). Membranes were blocked in tris-buffered saline (TBS) with 0.1% Tween-20 and 5% skim milk and blotted with the indicated primary overnight at 4°C. Horseradish peroxidase conjugated secondary antibodies were detected using ECL plus western blotting detection system (Amersham). The following antibodies were used: α E1A clone M58 and M37 (in house hybridoma supernatant), α GFP (Clontech 632592), α HA clone 3F10 (Roche 11867431001), α FLAG clone M2 (Sigma F-1804), α CtBP1 (BD Biosciences 612042), and α FOXK1 (Abcam Ab18196).

2.2.4 Immunofluorescence microscopy

Cells were fixed in 3.7% formaldehyde in phosphate-buffered saline (PBS), permeabilized on ice using 0.2% Triton X-100 and blocked using 5% goat serum in PBS.

Samples were incubated with primary antibody (α GFP) at room temperature for 1 h and for another hour at room temperature

Table 2-1 List of Primers used in PCR for plasmid construction

Construct	Primer Sequence (5' → 3')
P248	GGGGCACAGCGCGACCACCGGGTGTATCTC
K253	CTCACGGCAACTGGTTCAATGGGGCACAGCGGG
R258	GACGCCCACCAACTTCCACGGCAACTGGTTTAATGGGG
R262/263E	CATTCCACAGCCTGCTCTTCCCCACCAACTCTC
E267K	GTCCTCGATACATTTACAGCCTGGCGACG
D271K	CAGGCTCGTTAAGCAACTTCTCGATACATTCCACAGC
L272	GCCCAGACTCGTTAGCCGCGTCCTCGATACATTCC
L272	GCCCAGACTCGTTAGCCGCGTCCTCGATACATTCC
Δ PLDLS	CTTCTCGAGTTATGGCCTAGGACGTTTACATTGCCAGGCTCGTTAAGC
PLDLC	TAGTCTCGAGTTATGGCCTGGGGCGTTTACAGCACAAG
E1A-F	CGACGAATTCATGAGACATATTATCTGC
E1A-R	ACTGTCGACTTATGGCCTGGGACGTTTACAGCTC
Han11-F	GTAGAATTCATGTCCCTGCACGGCAAACGG
Han11-R	CAAGTCGACTACACGCGGAGTATCTCCAG
Qip1-F	ACTGGGATCCATGGCGGACAACGAGAAA
Qip1-R	CAGTCTCGAGAAACTGGAACCCTTCTGT

with secondary antibody (AlexaFluor-488 α Rabbit, Molecular Probes A-11008). Images were captured using a Nikon Eclipse Ti-S fluorescence microscope and pseudocolored using Velocity software. Confocal images were acquired with a Fluoview 1000 laser scanning confocal microscope (Olympus Corp).

2.2.5 Transformation Assays

Transformation of primary BRK cells by E1A in cooperation with activated EJ-Ras was assessed as described previously (Massimi and Banks 2005). Briefly, 9-day old BRK cells were transfected with EJ-Ras alone or together with wild-type or the indicated E1A mutant. The cells were placed under G418 selection for 2-3 weeks, and the formation of colonies was observed. Transformation assays in cooperation with HAdV-5 E1B-55K were done using primary HLREF cells as described previously (Turnell et al. 2005). Briefly, primary HLREFs were prepared from 18-day-old embryos and used at passage two. Cells were transfected with E1B-55k alone or together with wild-type or the indicated E1A mutant. Cells were placed under G418 selection and continued until day 14, when transformed foci were counted under lower power microscopy.

2.2.6 Statistical analysis

All numerical values represent means \pm S.E.M. Experiments were done in duplicate. Statistical significance was calculated using one way ANOVA and a Tukey's HSD post-hoc comparison.

2.3 Results

2.3.1 The E1A proteins from different HAdV species differ in their interaction with known targets of the C-terminus of HAdV5 E1A

We first sought to determine if the interactions carried out by the C-terminal region of HAdV5 E1A were conserved among different HAdV species. The largest isoforms of E1A from six HAdV types representing the six different species were tested for their ability to interact with each of the known cellular target proteins of the C-terminus of HAdV5 E1A. Specifically, we used HAdV type 12, 3, 5, 9, 4, and 40 from species A-F,

respectively. Lysates from human HT1080 fibrosarcoma cells expressing GFP fusions of E1A from each representative HAdV were immunoprecipitated using anti-GFP antibodies and subsequently immunoblotted for each cellular target (Figure 2.2). Initially, we examined the interaction with CtBP (Figure 2.2A), as this interaction is the best characterized of those occurring in the C-terminal portion of E1A. In HAdV5 E1A, CtBP interaction requires a PLDLS binding motif and this sequence or closely related variants are present in all described HAdV E1A proteins (Avvakumov et al. 2004). Surprisingly, CtBP interacted strongly with only three of the 6 E1As tested: HAdV5, 9, and 3. In contrast, HAdV12 E1A exhibited weaker binding, while minimal interaction with HAdV40 and 4 E1A was detected. Inspection of the CtBP interaction motif suggested that even minor deviation from the preferred PLDLS sequence (as seen in HAdV12, 4 and 40) reduced binding (Figure 2.2A). Furthermore, a point mutation at serine 283 to cysteine in HAdV5, which mimics the PLDLC motif found in HAdV4, completely abrogated the ability of HAdV5 to bind to CtBP (Figure 2.2B). We similarly investigated the ability of each different E1A protein to bind DYRK1A, HAN11 and FOXK1 (Figure 2.2C). All six representative E1As immunoprecipitated DYRK1A, although HAdV40 E1A bound more weakly. This data suggests that DYRK1A is a universally conserved binding partner of E1A. HAN11 was able to interact with HAdV5, 9, and 12, and weakly bound HAdV40, 4, and 3 E1A. Interestingly, the strength of the interaction for HAN11 paralleled the relative intensity of the DYRK1A interaction. As the FOXK1 binding region was previously mapped to a region specific to species C HAdV (Komorek et al. 2010), it was not surprising that only HAdV5 E1A of species C co-immunoprecipitated substantial amounts of FOXK1 (Figure 2.2B). Taken together, these results demonstrate that many of these binding partners of E1A are not consistently targeted across the different HAdV species.

2.3.2 Detailed mapping of the protein interactions mediated by the C-terminus of HAdV5 E1A

Previous studies of the C-terminus of HAdV5 E1A have utilized deletions to identify regions necessary for binding cellular targets (Zhang et al. 2001; Chinnadurai 2004; Komorek et al. 2010). However, some of these mutants, including a deletion of residues

Figure 2.2 Conservation of binding for the C-terminal targets of E1A

Human HT1080 cells were transfected with expression vectors for GFP-fusions of the largest E1A proteins from HAdV types 5, 40, 9, 4, 3, and 12 (A), a HAdV5 S283C point mutation (PLDLC) (B), or were co-transfected with expression vectors for HA tagged DYRK1A and HAN11 (C). Lysates were immunoprecipitated using anti-GFP antibodies and immunoblotted for each cellular target using anti-CtBP antibodies, anti-FOXK1 antibodies, and anti-HA antibodies, respectively.

A

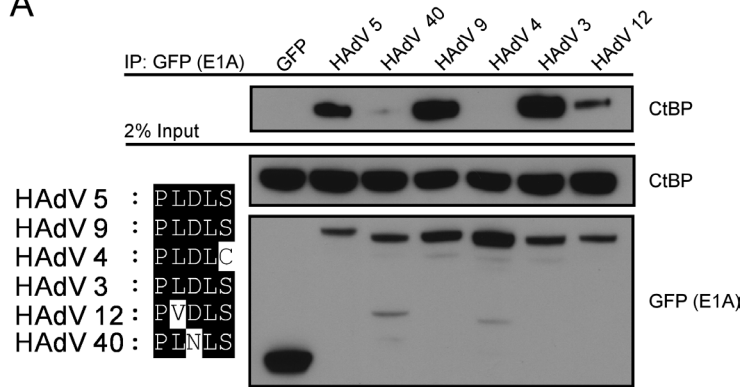

B

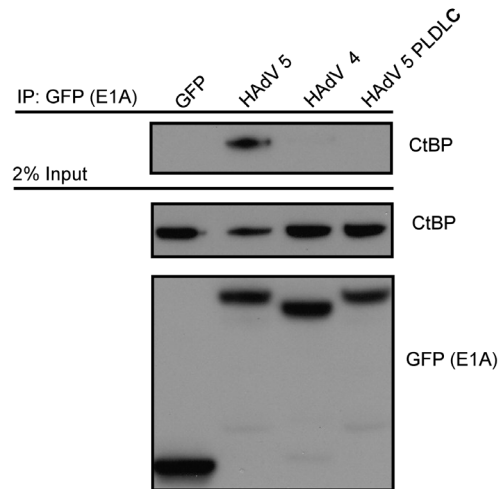

C

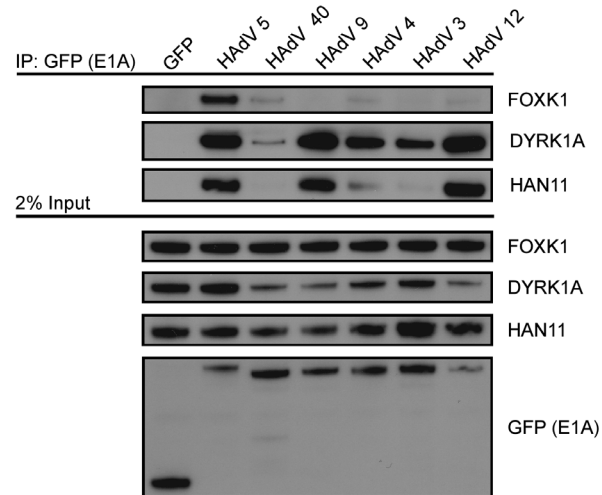

271-284 (dl1135), abrogate the interaction with multiple cellular targets thereby complicating the interpretation of their phenotypes (Figure 2.1). An amino acid sequence alignment of CR4 identified residues of high conservation among the E1A proteins of all 6 HAdV species (Figure 2.3). We targeted these residues by creating point mutants to determine if they were required for binding by HAdV5 E1A to each target of the C-terminus. Specifically, the following mutations were constructed: P248A, K253E, R258E, R262/263E, E267K, D271K, L272/273A. Additionally, a Δ PLDLS mutant was generated to precisely remove the CtBP interaction SLIM. HT1080 cells were transfected with vectors expressing GFP-tagged HAdV5 E1A or the panel of newly constructed mutants and either HA-tagged DYRK1A, or HA-tagged HAN11. Lysates were immunoprecipitated using anti-E1A antibodies and subsequently immunoblotted for each cellular target (Figure 2.4). As expected based on previous experiments, all point mutants were able to bind FOXK1, whereas a deletion within its binding region (residues 227-239) abrogated this interaction. The K253E, R258E, R262/263E, D271K, and L272/273A point mutations abrogated interaction with DYRK1A. Consistent with the pattern observed in Figure 2.2, mutants unable to interact with DYRK1A were also deficient for HAN11 binding. Importantly, the Δ PLDLS mutant was unable to interact with CtBP, yet retained interaction with FOXK1, DYRK1A and HAN11. Also, none of the new E1A point mutants dramatically reduced CtBP binding. Taken together, we have created mutations in HAdV5 E1A that specifically disrupt the binding of each particular C-terminal target, providing critical reagents to further characterize this region of E1A.

2.3.3 Efficient nuclear localization of HAdV5 E1A requires a region distinct from the canonical NLS

Previous analysis has shown that efficient nuclear localization of E1A is required for transformation by E1A in co-operation with E1B. Precise deletion of just the C-terminal NLS of E1A reduces foci yield by ~95% (Douglas and Quinlan 1994; Douglas and Quinlan 1995). Inexplicably, several internal mutants within the second exon of E1A distal from the canonical NLS are deficient for both nuclear localization and transforming ability in cooperation with E1B (Douglas and Quinlan 1995). To determine if any of our new point mutations affected nuclear localization of E1A, GFP-tagged mutants were

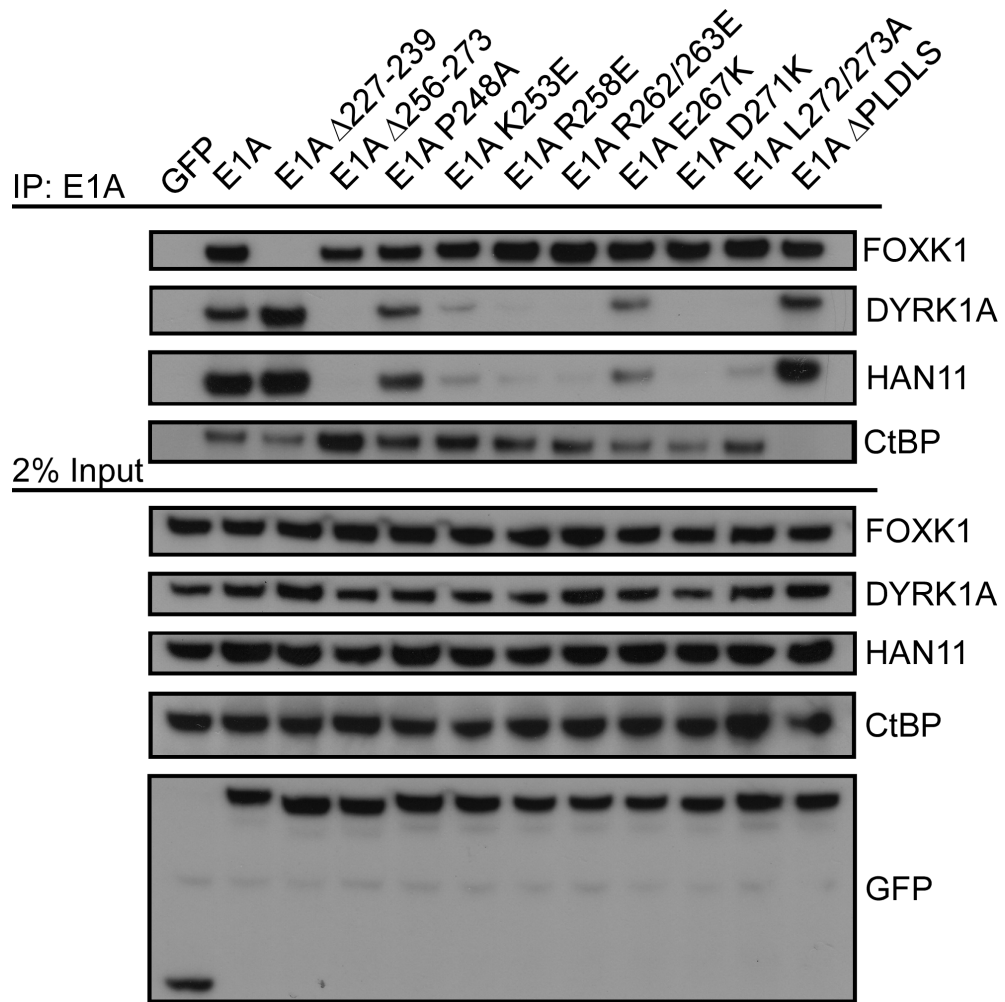

Figure 2.4 Detailed mapping of the protein interactions mediated by the C-terminus of HAdV5 E1A

Human HT1080 cells were co-transfected with expression vectors for GFP-fusions of wildtype (WT) 13S HAdV5 E1A or 13S E1A mutants and expression vectors for HA-fusions of DYRK1A and HAN11. Lysates were immunoprecipitated using anti-E1A antibodies (M37 and M58) and immunoblotted for each cellular target using anti-FOXK1 antibodies, anti-HA antibodies, and anti-CtBP antibodies, respectively.

expressed in human HeLa cervical carcinoma cells and then visualized using conventional and confocal fluorescence microscopy (Figures 2.5 and 2.6, respectively). While most point mutants retained a primarily nuclear localization phenotype similar to that of WT E1A (Figure 2.5), the R262/263E mutant, which was unable to interact with either DYRK1A or HAN11 (Figure 2.4), exhibited a nuclear/cytoplasmic phenotype (Figures 2.5H and 2.6E). This phenotype is consistent with that observed for the Δ 256-273 deletion mutant (Douglas and Quinlan 1995), which fully removes the DYRK1A and HAN11 binding region (Figures 2.5D and 2.6D).

E1A specifically interacts with importin- α 3/Qip1 to induce rapid nuclear import (Lyons et al. 1987; Kohler et al. 2001). We also determined if the mutants displaying defective nuclear localization exhibited a reduced interaction with Qip1. Cells expressing our panel of GFP-tagged E1A mutants and FLAG-tagged Qip1 were immunoprecipitated using anti-FLAG antibodies and subsequently immunoblotted for E1A (Figure 2.7). As expected, deletion of the canonical NLS (Δ 285-289) abrogated interaction with Qip1. Interestingly, both the R262/263E and Δ 256-273 mutant exhibited a substantially reduced interaction with Qip1. These results confirm the importance of this second region of E1A for efficient nuclear localization.

2.3.4 E1A-mediated transformation of rodent cells in cooperation with E1B-55K is enhanced by the interaction with DYRK1A and HAN11 and requires CtBP binding

The C-terminus of E1A is necessary for oncogenic transformation of rodent cells in cooperation with E1B (Subramanian et al. 1991). Using the panel of new point mutants, we sought to specifically identify which C-terminal targets of HAdV5 E1A were required for oncogenic transformation of rodent cells in cooperation with E1B-55K. HLREF cells were co-transfected with expression vectors for our panel of 12S E1A mutants and with HAdV5 E1B-55K. Transformation was determined by counting transformed foci (Figure 2.8A). An E1A mutant unable to bind the retinoblastoma protein (Δ 111-123), which is unable to transform in this context, was used as a negative control (Jelsma et al. 1989). Transfection with the R258E, R262/263E and L272/273A mutants resulted in significantly fewer foci than that of WT E1A in

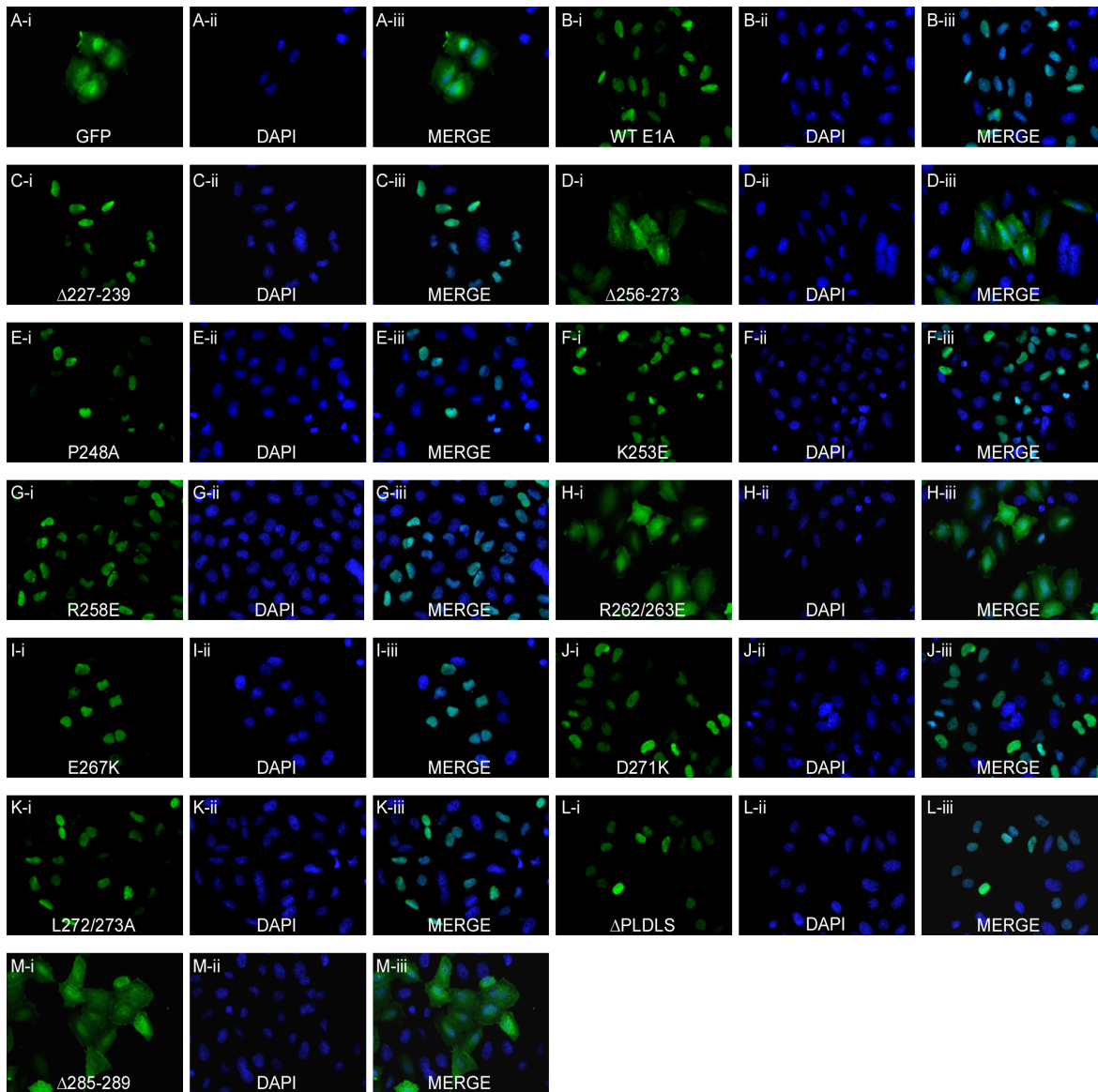

Figure 2.5 Subcellular localization of the C-terminal E1A mutants

Human HeLa cervical carcinoma cells were transfected with expression vectors for GFP-fusions of WT HAdV5 E1A or the indicated E1A deletion or point mutant and were subjected to fluorescence microscopy. Nuclei were stained with DAPI.

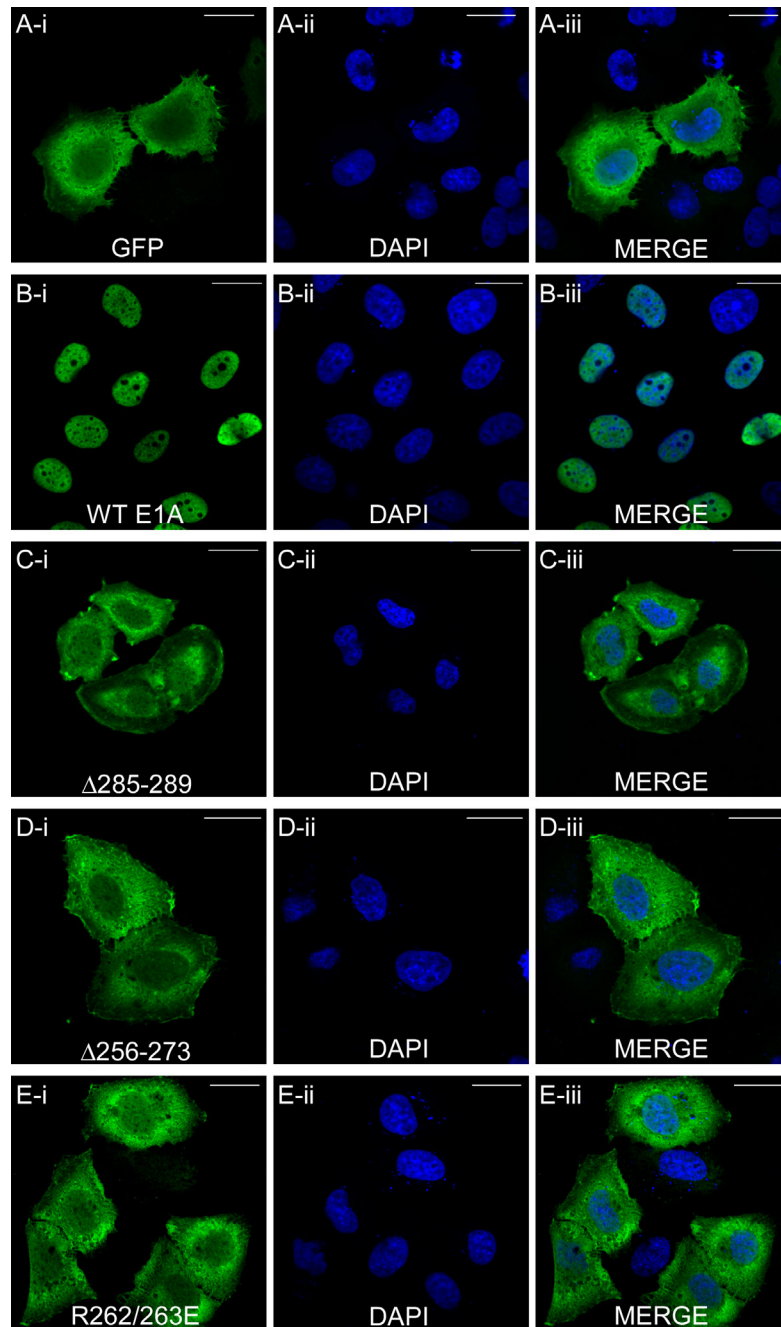

Figure 2.6 Analysis of E1A mutants exhibiting a nuclear/cytoplasmic phenotype by confocal microscopy

Human HeLa cervical carcinoma cells were transfected with expression vectors for GFP-fusions of WT HA Δ V5 E1A or the indicated E1A deletion and point mutants and were subjected to confocal fluorescence microscopy. Nuclei were stained with DAPI. White bars represent 20 μ m.

cooperation with E1B-55K. These mutants were also deficient in binding DYRK1A and HAN11. Interestingly, the E267K mutant which retained binding to all known targets exhibited significantly reduced transformation. The Δ PLDLS mutant, which does not bind CtBP, but binds all other targets, also resulted in significantly decreased transforming ability. This confirms that the interaction of CtBP with E1A is essential for transformation (Subramanian et al. 1991; Boyd et al. 1993; Chinnadurai 2004). Taken together, oncogenic transformation of rodent cells by E1A and E1B-55K appears to require interaction with multiple cellular targets.

2.3.5 E1A's interaction with other targets, but not with CtBP, is required for suppression of Ras mediated transformation of rodent cells

It has been established that deletions within residues 224-285 of HAdV5 E1A lead to significantly enhanced transformation when co-expressed with activated Ras (Subramanian et al. 1989; Douglas et al. 1991; Boyd et al. 1993). We determined if any of our new point mutants would lose the ability to partially suppress Ras mediated transformation and so, similarly exhibit this hypertransforming phenotype. To test this, primary BRK cells were co-transfected with each of the new HAdV5 E1A mutants and EJ-Ras (Figure 2.8B). Transforming ability was quantified as described above. Consistent with previous reports, Δ 256-273 clearly exhibited the hypertransforming phenotype (Douglas et al. 1991). Indeed, BRK cells transfected with this mutant produced nearly 4 fold more foci as compared to cells transfected with WT E1A. The R262/263E point mutant and to a lesser extent the D271K mutant similarly exhibited a transforming ability higher than WT E1A. These results suggest that DYRK1A and HAN11 may play critical roles in E1A C-terminal dependent suppression of Ras-mediated transformation. However, it should be noted that other E1A mutants that failed to interact with DYRK1A or HAN11 did not exhibit the hypertransforming phenotype, including K253E, R258E and L272/273A.

Based on previous data regarding the nuclear localization of E1A, we hypothesized that a combination of both the inability to bind DYRK1A and HAN11, and impaired nuclear localization is required to induce hyper-transformation. To test this, we engineered

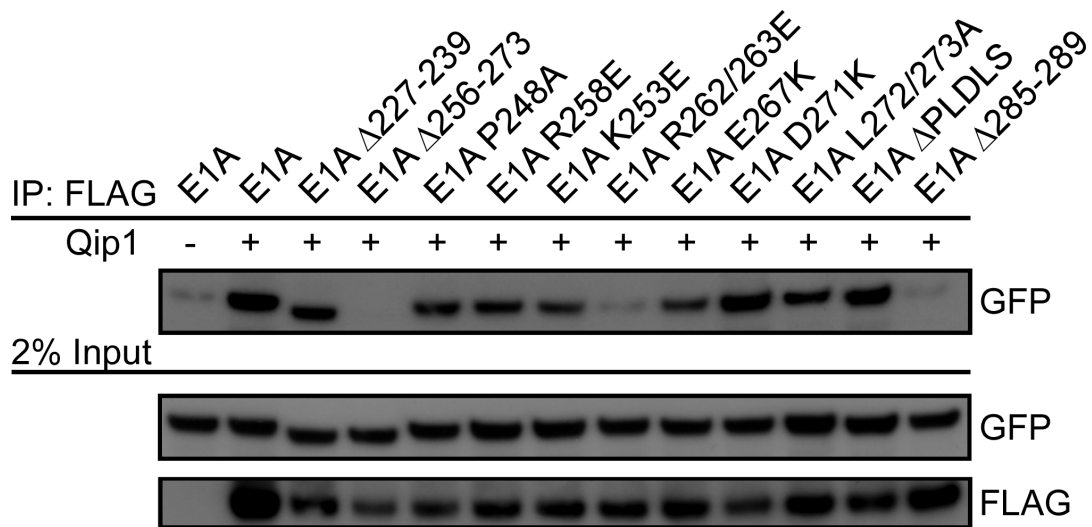

Figure 2.7 E1A mutants exhibiting a nuclear/cytoplasmic phenotype have a deficiency in Qip1 binding

Human HT180 cells were co-transfected with expression vectors for GFP-fusions of WT HAdV5 13S E1A or the indicated E1A mutants and expression vectors for FLAG-tagged Qip1. Lysates were immunoprecipitated using anti-FLAG antibodies and immunoblotted for E1A using anti-GFP antibodies.

another panel of E1A mutants in which the NLS (residues 285-289) was removed from each E1A point mutant used in our previous experiments. We subsequently determined the ability of each E1A double mutant to transform BRK cells in cooperation with Ras as described above (data not shown). However, mutants with reduced nuclear localization and DYRK1A and HAN11 interaction did not consistently induce hypertransformation in cooperation with Ras. Further investigation as to why only select mutants that fail to bind to DYRK1A or HAN11 lead to hypertransformation is therefore necessary.

Surprisingly, the Δ PLDLS mutant, which does not bind CtBP, did not induce the hypertransforming phenotype. This clearly indicates that the interaction of E1A with CtBP is not required to suppress transformation in cooperation with Ras. This result was unexpected, as it has been previously suggested that the CtBP interaction is essential for suppressing transformation by E1A and activated Ras (Schaeper et al. 1995; Chinnadurai 2004). However, crucially, this has never been tested using the Δ PLDLS mutant, which removes interaction with CtBP without affecting DYRK1A or HAN11 binding.

2.4 Discussion

Mutational analysis of HAdV5 E1A has been an invaluable tool to study the functions of this viral oncoprotein. However, the recent discovery of new targets that bind the C-terminus of E1A necessitates further characterization of this region, as previous studies operated under the assumption that CtBP was the only important target of this region. Indeed, data from E1A deletion mutants, which we now know disrupt binding to multiple partners, led to the formulation of conclusions which are no longer supported by the current data. This is specifically the case with the mutant Δ 271-284 (dl1135), which does not bind DYRK1A, HAN11 and CtBP. In this report, we created a panel of new E1A C-terminus mutants that disrupt binding to only one of the above mentioned targets at a time. These new mutants allowed us to better characterize how the C-terminus of E1A carries out its functions.

We initially determined the level at which these targets are conserved among the E1A proteins of different HAdV species and the known C-terminal targets (Figure 2.2). Unexpectedly, the interaction between E1A and CtBP was not highly conserved despite

Figure 2.8 Ability of C-terminal E1A mutants to oncogenically transform primary rodent cells in cooperation with E1B or activated Ras

A) HLREF were co-transfected with expression vectors for WT HAdV5 12S E1A or 12S E1A mutants and an expression vector for E1B-55K. Cells were incubated under G418 selection for 14 days and transformed foci were counted under low-power microscopy. Statistically significant decrease in colony numbers from WT 12S E1A is indicated (* $P < 0.05$). B) Primary baby rat kidney cells were co-transfected with expression vectors for WT HAdV5 12S E1A or 12S E1A mutants and an expression vector for EJ-Ras. Cells were treated and counted as described above. Statistically significant increases in colony numbers from WT E1A are indicated (* $P < 0.05$).

A

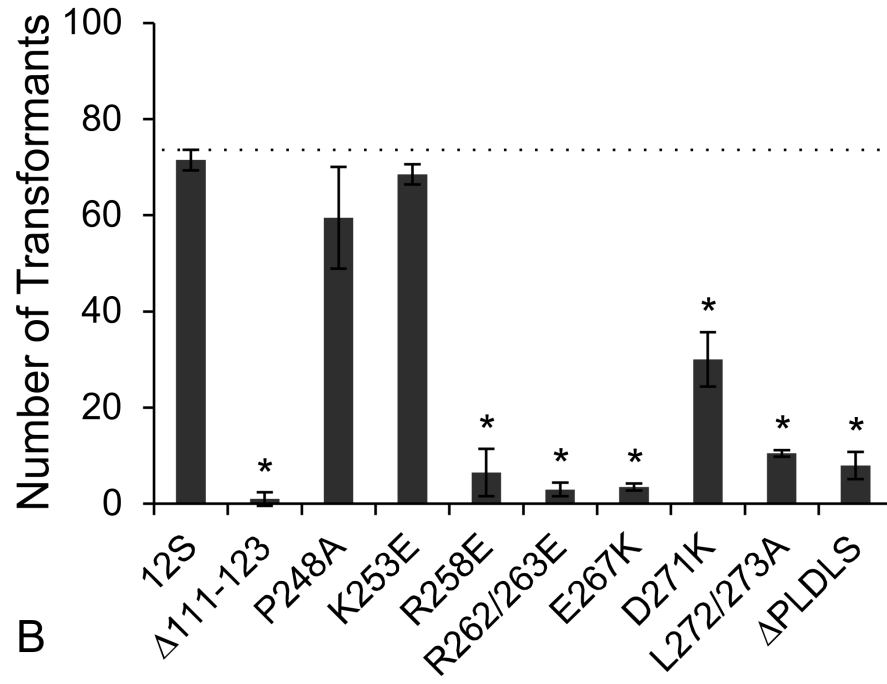

B

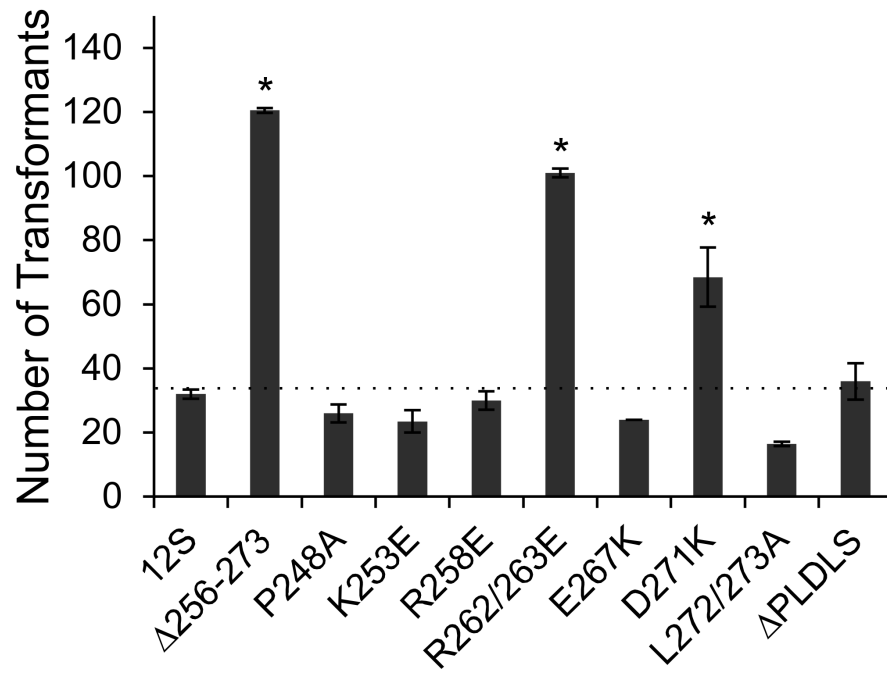

the presence of a PLDLS like motif in each of the E1A proteins (Figure 2.2A). It appeared that any deviation from the preferred PLDLS CtBP SLIM reduced or abrogated binding to CtBP, as seen with HAdV 4, 12 and 40 E1A. This has similarly been reported for the cellular homeodomain protein TGIF, in which a naturally occurring mutation from PLDLS to PLDLC blocks its interaction with CtBP (Melhuish and Wotton 2000; Avvakumov et al. 2004). The binding site for FOXK1 is present only in the E1A proteins of HAdV species C (Avvakumov et al. 2004; Komorek et al. 2010). We confirmed HAdV5 E1A binds FOXK1 far more strongly than the E1A proteins of the other HAdVs (Figure 2.2B). Interestingly, the most conserved interaction was with DYRK1A and HAN11 (Figure 2.2B), suggesting that interaction of E1A with DYRK and HAN11 is highly beneficial to viral infection.

We next created an extensive panel of point mutants within CR4 of HAdV5 and an additional mutant deleting the conserved PLDLS SLIM that binds CtBP (Figure 2.3). These were tested for their ability to bind the known cellular targets of the C-terminus of E1A: CtBP, DYRK1A, HAN11 and FOXK1. We found that specific amino acids within the previously described DYRK1A and HAN11 binding region were necessary for these interactions, yet still retained binding to the other C-terminal targets. Notably, the ability of each mutant to bind DYRK1A paralleled its ability to interact with HAN11 (Figure 2.4). We have previously shown that E1A binds to recombinant GST fused DYRK1A and DYRK1B *in vitro* (Zhang et al. 2001). As HAN11 is a co-factor of DYRK1A (Morita et al. 2006), it is possible that E1A interacts with HAN11 indirectly through DYRK1A. As expected, the Δ PLDLS mutant specifically abrogated the interaction between CtBP and E1A, but did not interfere with binding to any other target. This provided us with mutants that have lost the ability to bind DYRK1A and HAN11 without affecting interaction with CtBP and vice versa. Previous studies on E1A's interaction with CtBP focused on mutants that also failed to bind other targets, making it difficult to draw clear conclusions about the importance of this interaction to E1A function (Boyd et al. 1993; Schaeper et al. 1995).

The subcellular localization of all point mutants was also determined, as deletions distant from the well characterized monopartite NLS of E1A can influence nuclear import and

E1A function. Like WT E1A, all the point mutants were exclusively nuclear, with the exception of the R262/263E mutant (Figure 2.6E). R262/263E exhibited a nuclear/cytoplasmic phenotype, similar to the localization of the previously documented $\Delta 256-273$ and $\Delta 285-289$ mutants (Figure 2.6C and 6D) (Douglas and Quinlan 1995). Interestingly, mutants outside of the NLS (285-289) with reduced nuclear localization alter a cluster of basic amino acids including R262 and R263. As basic residues often demarcate an NLS, this raised the possibility that this region functions in concert with the well characterized NLS (285KRPRP289) to form a bipartite NLS. Indeed, a novel bipartite NLS spanning residues 258 to 289 in HAdV5 E1A (258RVGGRRQAVECIEDLLNEPGQPLDLSCKRPRP289) was predicted using a new-generation *in silico* prediction software, cNLS Mapper (Kosugi et al. 2009). Thus, the previously described monopartite NLS located at the C-terminus of E1A may represent only one portion of a bipartite NLS. This is further supported by the observation that the R262/263E, $\Delta 256-273$ and $\Delta 285-289$ mutants each interact far less strongly with the Qip1 importin than WT E1A (Figure 2.7). Taken together, these results suggest that full nuclear localization requires the well characterized NLS spanning residues 285-289 as well as the second basic patch around residues 262 and 263, both of which are conserved in all 6 species (Figure 2.3). Future studies will be necessary to verify and expand on this observation, which alters our understanding of one of the oldest documented NLSs (Lyons et al. 1987).

Having created E1A mutants which specifically remove interactions with each C-terminal target in isolation, we sought to determine which of these interactions were necessary to transform cells in cooperation with E1B-55K. Based on previous analysis, the FOXK1 binding site falls outside of the region required for immortalization by E1A (Komorek et al. 2010; Yousef et al. 2012). In contrast, the failure of the Δ PLDLS mutant to transform rodent cells with E1B definitively shows that interaction with CtBP is necessary for this activity (Figure 2.8A). Importantly, specific point mutants unable to bind DYRK1A or HAN11 (R258E, R262/263E, D271K and L272/273A) were also defective for transformation with E1B-55K (Figure 2.7A). Although K253E bound DYRK1A weakly, this residual binding may be sufficient to explain its WT transformation activity. Despite binding DYRK1A, E267K was unable to transform, suggesting that it either fails to bind

another factor required for transformation or does not interact productively with DYRK1A. These data suggest that the interaction of E1A with DYRK1A plays an important role in transformation with E1B-55K. Furthermore, these results confirm that the CtBP interaction is necessary for this function.

Although required for transformation with E1B, the C-terminus of E1A suppresses transformation in cooperation with activated Ras, and this has been suggested to require interaction with CtBP (Schaeper et al. 1995; Chinnadurai 2004; Komorek et al.). In these assays, several of the new mutants exhibit a strong hypertransforming phenotype similar to that observed with the $\Delta 256-273$ mutant (Figure 2.7B). These include the R262/263E and D271K mutants, which did not bind DYRK1A or HAN11. However, other mutants that do not bind DYRK1A and HAN11, including R258E and L272/273A, did not exhibit the hypertransformation phenotype. It is unclear at this time why only specific point mutations that fail to bind DYRK1A contribute to hypertransformation with Ras.

What is most striking from this study is that the interaction with CtBP via the PLDLS SLIM was, in fact, not required for suppression of Ras mediated transformation by E1A. This contrasts with a previous model based on data obtained using E1A mutants that fail to bind multiple factors. Indeed, past studies typically utilized deletion of residues 271-284, which removes both the conserved PLDLS SLIM as well as a necessary portion of the DYRK1A and HAN11 binding region (Boyd et al. 1993). The Δ PLDLS mutant used in this study disrupts the CtBP interaction without compromising DYRK1A or HAN11 binding (Figure 2.4) and clearly does not display a hypertransforming phenotype (Figure 2.8B).

While this study was under peer review, another investigation of the roles of various targets of the E1A C-terminal region in immortalization, transformation with Ras and tumourigenesis was published (Subramanian et al. 2013). In that study, E1A mutants unable to bind CtBP or DYRK1A/HAN11 displayed enhanced immortalization. In contrast, individual E1A mutations affecting FOXK1/FOXK2, DYRK1A/HAN11 or CtBP binding exhibited enhanced transformation with Ras and only those mutants with impaired binding to FOXK1/FOXK2 or DYRK1/HAN11 displayed enhanced

tumorigenic potential in athymic mice. These results differ from previously published data and our conclusions in several instances. Specifically, deletion of the FOXK1/FOXK2 binding region was previously reported to lead to enhanced immortalization, and deletion of the DYRK1A/HAN11 binding region reduced immortalization (Boyd et al. 1993; Douglas and Quinlan 1995). Similarly, enhanced transformation with Ras was not observed for mutants unable to bind DYRK1A/HAN11 (Boyd et al. 1993) or CtBP (Figure 2.8B) and tumorigenesis in athymic mice was not enhanced by deletion of the FOXK1/FOXK2 binding region (Boyd et al. 1993). In some cases, these differences may be related to the use of different mutants. However, it is clear that the roles of these targets of the E1A C-terminus in oncogenesis are complex and may differ depending on the exact assay conditions utilized.

Currently, the mechanism by which DYRK1A and HAN11 modulate E1A-dependent transformation is unknown. We have previously shown that E1A is able to enhance the kinase activity of DYRK1A *in vitro* (Zhang et al. 2001). It is possible that this E1A-dependent enhanced DYRK1A kinase activity affects multiple downstream targets, thereby making the cells susceptible to oncogenic transformation in cooperation with E1B or suppressing Ras-dependent transformation.

Interestingly, DYRK1A has been implicated in the phenomenon of oncogene-induced senescence (Litovchick et al. 2011). Specifically, DYRK1A phosphorylates LIN52, a member of the MUVB core complex. This activity triggers assembly of the DREAM complex (DP, RB, E2F, and MuvB), which promotes entry into quiescence, growth suppression and senescence (Litovchick et al. 2007; Pilkinton et al. 2007). Phosphorylation of LIN52 was shown to be essential for DREAM assembly. Importantly, the interaction between DYRK1A and LIN52 appears to be required for both growth arrest and oncogenic Ras-induced senescence (Litovchick et al. 2011). It is tempting to speculate that the presence of E1A stimulates the kinase activity of DYRK1A, thereby enhancing the process of Ras-induced senescence. By sensitizing cells to oncogene-induced senescence, the C-terminus of E1A would suppress Ras dependent transformation.

Taken together, we have characterized and mapped the binding sites of all of the identified cellular targets of the C-terminal region of E1A. By creating point mutants in this region that are specifically deficient for binding individual targets, we can better understand how this critical region functions in transformation and nuclear localization. Significantly, this study provides new evidence that DYRK1A regulates oncogenesis.

2.5 References

- Avvakumov, N., A. E. Karon, R. C. Hoeben and J. S. Mymryk (2004). "Comprehensive sequence analysis of the E1A proteins of human and simian adenoviruses." Virology **329**(2): 477-92.
- Avvakumov, N., M. Sahbegovic, Z. Zhang, M. Shuen and J. S. Mymryk (2002). "Analysis of DNA binding by the adenovirus type 5 E1A oncoprotein." J Gen Virol **83**(Pt 3): 517-24.
- Bayley, S. and J. Mymryk (1994). "Adenovirus e1a proteins and transformation (review)." Int J Oncol **5**(3): 425-44.
- Boyd, J. M., T. Subramanian, U. Schaeper, M. La Regina, S. Bayley and G. Chinnadurai (1993). "A region in the C-terminus of adenovirus 2/5 E1a protein is required for association with a cellular phosphoprotein and important for the negative modulation of T24-ras mediated transformation, tumorigenesis and metastasis." Embo J **12**(2): 469-78.
- Chinnadurai, G. (2004). "Modulation of oncogenic transformation by the human adenovirus E1A C-terminal region." Curr Top Microbiol Immunol **273**: 139-61.
- Douglas, J. L., S. Gopalakrishnan and M. P. Quinlan (1991). "Modulation of transformation of primary epithelial cells by the second exon of the Ad5 E1A12S gene." Oncogene **6**(11): 2093-103.
- Douglas, J. L. and M. P. Quinlan (1994). "Efficient nuclear localization of the Ad5 E1A 12S protein is necessary for immortalization but not cotransformation of primary epithelial cells." Cell Growth Differ **5**(5): 475-83.
- Douglas, J. L. and M. P. Quinlan (1995). "Efficient nuclear localization and immortalizing ability, two functions dependent on the adenovirus type 5 (Ad5) E1A second exon, are necessary for cotransformation with Ad5 E1B but not with T24ras." J Virol **69**(12): 8061-5.

- Flint, J. and T. Shenk (1997). "Viral transactivating proteins." Annu Rev Genet **31**: 177-212.
- Fonseca, G. J., G. Thillainadesan, A. F. Yousef, J. N. Ablack, K. L. Mossman, J. Torchia and J. S. Mymryk (2012). "Adenovirus evasion of interferon-mediated innate immunity by direct antagonism of a cellular histone posttranslational modification." Cell Host Microbe **11**(6): 597-606.
- Gallimore, P. H. and A. S. Turnell (2001). "Adenovirus E1A: remodelling the host cell, a life or death experience." Oncogene **20**(54): 7824-35.
- Jelsma, T. N., J. A. Howe, C. M. Eveleigh, N. F. Cunniff, M. H. Skiadopoulos, M. R. Floroff, J. E. Denman and S. T. Bayley (1988). "Use of deletion and point mutants spanning the coding region of the adenovirus 5 E1A gene to define a domain that is essential for transcriptional activation." Virology **163**(2): 494-502.
- Jelsma, T. N., J. A. Howe, J. S. Mymryk, C. M. Eveleigh, N. F. Cunniff and S. T. Bayley (1989). "Sequences in E1A proteins of human adenovirus 5 required for cell transformation, repression of a transcriptional enhancer, and induction of proliferating cell nuclear antigen." Virology **171**(1): 120-30.
- Kentrup, H., W. Becker, J. Heukelbach, A. Wilmes, A. Schurmann, C. Huppertz, H. Kainulainen and H. G. Joost (1996). "Dyrk, a dual specificity protein kinase with unique structural features whose activity is dependent on tyrosine residues between subdomains VII and VIII." J Biol Chem **271**(7): 3488-95.
- Kohler, M., D. Gorlich, E. Hartmann and J. Franke (2001). "Adenoviral E1A protein nuclear import is preferentially mediated by importin alpha3 in vitro." Virology **289**(2): 186-91.
- Komorek, J., M. Kuppuswamy, T. Subramanian, S. Vijayalingam, E. Lomonosova, L. J. Zhao, J. S. Mymryk, K. Schmitt and G. Chinnadurai (2010). "Adenovirus type 5 E1A and E6 proteins of low-risk cutaneous beta-human papillomaviruses suppress cell transformation through interaction with FOXK1/K2 transcription factors." J Virol **84**(6): 2719-31.
- Kosugi, S., M. Hasebe, M. Tomita and H. Yanagawa (2009). "Systematic identification of cell cycle-dependent yeast nucleocytoplasmic shuttling proteins by prediction of composite motifs." Proc Natl Acad Sci U S A **106**(25): 10171-6.
- Litovchick, L., L. A. Florens, S. K. Swanson, M. P. Washburn and J. A. Decaprio (2011). "DYRK1A protein kinase promotes quiescence and senescence through DREAM complex assembly." Genes Dev **25**(8): 801-13.

- Litovchick, L., S. Sadasivam, L. Florens, X. Zhu, S. K. Swanson, S. Velmurugan, R. Chen, M. P. Washburn, X. S. Liu and J. A. DeCaprio (2007). "Evolutionarily conserved multisubunit RBL2/p130 and E2F4 protein complex represses human cell cycle-dependent genes in quiescence." Mol Cell **26**(4): 539-51.
- Lyons, R. H., B. Q. Ferguson and M. Rosenberg (1987). "Pentapeptide nuclear localization signal in adenovirus E1a." Mol Cell Biol **7**(7): 2451-6.
- Massimi, P. and L. Banks (2005). "Transformation assays for HPV oncoproteins." Methods Mol Med **119**: 381-95.
- Melhuish, T. A. and D. Wotton (2000). "The interaction of the carboxyl terminus-binding protein with the Smad corepressor TGIF is disrupted by a holoprosencephaly mutation in TGIF." J Biol Chem **275**(50): 39762-6.
- Morita, K., C. Lo Celso, B. Spencer-Dene, C. C. Zouboulis and F. M. Watt (2006). "HAN11 binds mDia1 and controls GLI1 transcriptional activity." J Dermatol Sci **44**(1): 11-20.
- Nishinaka, Y., H. Masutani, S. Oka, Y. Matsuo, Y. Yamaguchi, K. Nishio, Y. Ishii and J. Yodoi (2004). "Importin alpha 1 (Rch1) mediates nuclear translocation of thioredoxin-binding protein-2/vitamin D(3)-up-regulated protein 1." J Biol Chem **279**(36): 37559-65.
- Pelka, P., J. N. Ablack, G. J. Fonseca, A. F. Yousef and J. S. Mymryk (2008). "Intrinsic structural disorder in adenovirus E1A: a viral molecular hub linking multiple diverse processes." J Virol **82**(15): 7252-63.
- Pilkinton, M., R. Sandoval and O. R. Colamonici (2007). "Mammalian Mip/LIN-9 interacts with either the p107, p130/E2F4 repressor complex or B-Myb in a cell cycle-phase-dependent context distinct from the Drosophila dREAM complex." Oncogene **26**(54): 7535-43.
- Schaeper, U., J. M. Boyd, S. Verma, E. Uhlmann, T. Subramanian and G. Chinnadurai (1995). "Molecular cloning and characterization of a cellular phosphoprotein that interacts with a conserved C-terminal domain of adenovirus E1A involved in negative modulation of oncogenic transformation." Proc Natl Acad Sci U S A **92**(23): 10467-71.
- Subramanian, T., M. La Regina and G. Chinnadurai (1989). "Enhanced ras oncogene mediated cell transformation and tumorigenesis by adenovirus 2 mutants lacking the C-terminal region of E1a protein." Oncogene **4**(4): 415-20.

- Subramanian, T., S. E. Malstrom and G. Chinnadurai (1991). "Requirement of the C-terminal region of adenovirus E1a for cell transformation in cooperation with E1b." Oncogene **6**(7): 1171-3.
- Subramanian, T., L. J. Zhao and G. Chinnadurai (2013). "Interaction of CtBP with adenovirus E1A suppresses immortalization of primary epithelial cells and enhances virus replication during productive infection." Virology.
- Turnell, A. S., G. S. Stewart, R. J. Grand, S. M. Rookes, A. Martin, H. Yamano, S. J. Elledge and P. H. Gallimore (2005). "The APC/C and CBP/p300 cooperate to regulate transcription and cell-cycle progression." Nature **438**(7068): 690-5.
- Yousef, A. F., G. J. Fonseca, M. J. Cohen and J. S. Mymryk (2012). "The C-terminal region of E1A: a molecular tool for cellular cartography." Biochem Cell Biol **90**(2): 153-63.
- Zhang, Z., M. M. Smith and J. S. Mymryk (2001). "Interaction of the E1A oncoprotein with Yak1p, a novel regulator of yeast pseudohyphal differentiation, and related mammalian kinases." Mol Biol Cell **12**(3): 699-710.

Chapter 3

3 Functional analysis of the C-terminal region of human adenovirus E1A reveals a misidentified nuclear localization signal

3.1 Introduction

The HAdV E1A oncoprotein is the first viral protein to be expressed following infection (Pelka et al. 2008). E1A plays a critical role in reprogramming the infected cell by modulating host transcriptional machinery to force quiescent cells to enter the cell cycle and suppress the cellular innate antiviral responses thereby providing an optimal environment for viral replication (Bayley and Mymryk 1994; Flint and Shenk 1997). E1A has no enzymatic or specific DNA binding capabilities and instead carries out its functions by binding to and manipulating a plethora of key cellular regulatory proteins through short linear motifs found within its 289 amino acid sequence (Avvakumov et al. 2002; Pelka et al. 2008). Based on amino acid similarity among different HAdV species, there are four regions of high conservation within the E1A sequence termed conserved regions 1 to 4 (CR1 to CR4) and it is typically within these regions that the linear motifs are located (Avvakumov et al. 2004; Pelka et al. 2008). This strategy allows E1A to interact with over 50 cellular targets and associate with over 17,000 genomic promoters (Ferrari et al. 2008; Ferrari et al. 2009).

The specific subcellular localization of any protein is essential for its given functions. Proteins targeted to the nucleus contain NLSs that typically interact in the cytosol with the importin- α family of NLS receptors (also known as karyopherin α) (Macara 2001). Importin- α recognizes two classes of NLSs: monopartite NLSs, which have a single cluster of basic amino acid residues and bipartite NLSs, which have two clusters of basic residues separated by a linker region of 10-25 amino acids (Lange et al. 2007; Lange et al. 2010). The prototypical monopartite signal is exemplified by the SV40 Large T antigen (T-Ag) NLS (¹²⁶PKKKRKV¹³²) (Kalderon et al. 1984), while bipartite signals are exemplified by the *Xenopus laevis* nucleoplasmin NLS (¹⁵⁵KRPAATKKAGQAKKK¹⁷⁰) (Dingwall et al. 1988).

Translocation from the cytoplasm to the nucleus is a necessary process for E1A to gain access to the members of its target complexes (Douglas and Quinlan 1995; Madison et al. 2002). E1A contains a highly conserved monopartite NLS, a conserved five amino acid sequence mapped to the extreme C-terminus of E1A (²⁸⁵KRPRP²⁸⁹) (Figure 3.1) that preferentially interacts with importin alpha 3 (Qip1) (Lyons et al. 1987; Kohler et al. 2001). A second non-canonical NLS was identified in CR3 of HAdV-5 E1A with the consensus sequence FV(X)7-26MXSLYXYM(X)4MF (Slavicek et al. 1989; Standiford and Richter 1992). Unlike the C-terminal NLS, this sequence is not conserved and is unique to HAdV-5 E1A. However, using a genetic assay in *Saccharomyces cerevisiae*, we recently showed that the CR3 region from all HAdV species is able to induce nuclear localization, indicating the presence of a non-canonical NLS which does not follow the previously reported consensus sequence. In this same study we reported yet another novel non-canonical NLS in the N-terminal region of E1A mapped to residues 30-69 (Marshall et al. 2014).

Previous analysis has shown that efficient nuclear localization of E1A is required for the immortalization and transformation by E1A in cooperation with HAdV E1B (Douglas and Quinlan 1994; Douglas and Quinlan 1995). These studies also revealed that inexplicably, mutations in other regions within the second exon of E1A distal from the canonical C-terminal NLS were deficient for both nuclear localization and transforming ability with E1B. We recently conducted an extensive mutational analysis of the C-terminal region of E1A as a means of identifying key amino acid residues required for interaction with several cellular targets. During this study, we observed that the amino acid substitution at the highly conserved residues 262 and 263 (R262/263E) of HAdV E1A resulted in a deficiency in nuclear localization (Cohen et al. 2013). The localization phenotype of this double point mutant was consistent with that of the previously described E1A mutant with a deletion that spans residues 256-273 (Douglas and Quinlan 1994). Furthermore, the R262/R263E mutant was unable to interact with Qip1 in co-immunoprecipitation (co-IP) assays. Other highly conserved basic residues are also situated within this region of E1A (K253 and R258 specifically) (Figure 3.1) and interestingly, a bipartite NLS was predicted for E1A *in silico*, spanning residues 258-289 (Cohen et al. 2013).

In the current study, we have verified that the C-terminal region of E1A indeed contains a bona fide bipartite NLS (258RVGGRRQAVECIEDLLNEPGQPLDLCKRPRP289) that is both necessary and sufficient for nuclear localization.

3.2 Materials and Methods

3.2.1 Cell lines, cell culture, and transfections

HT-1080 and HeLa cells were grown at 37°C with 5% CO₂ in DMEM supplemented with 10% FBS. Plasmids were transfected into HT-1080 and HeLa cells using XtremeGeneHP (Roche) and used for experimentation 24 hours later.

3.2.2 Plasmids

All HAdV5 E1A constructs and nuclear localization sequences were expressed as fusions with EGFP at the N-terminus. E1As with the R262/263E mutation were constructed using the following mutagenic primer:

5'-TACAGAATTCGAAGAGCAGGCTGTGGAA-3'.

E1A NLS (SCKRPRP), SV40 T-Ag NLS (PKKKRKV), and Nucleoplasmin NLS (KRPAATKKAGQAKKKK) were cloned using self-annealing primer pairs. WT Qip1, or mutants lacking the major and minor NLS binding sites (Δ Major and Δ Minor) were subcloned into pcDNA4-HA from plasmids kindly provided by Dr. Shunichi Kosugi (Institute for Advanced Biosciences, Keio University, Tsuruoka, Japan) (Okazaki et al.). Qip1 WT lacks the importin- β binding domain (residues 1–55). The Qip1 major and minor pocket mutants are derivatives of Qip1 WT, but contain two alanine substitutions at W179/N183 and W390/N394, respectively.

3.2.3 Western blotting and co-immunoprecipitation

Cells were lysed with NP40 lysis buffer and protein concentrations were determined with BioRad protein assay reagent using bovine serum albumin (BSA) as a standard. 0.5mg of protein lysate was immunoprecipitated with the indicated antibodies at 4°C overnight. 10 μ g of protein was kept as 2% input. After 3 washes in NP40 lysis buffer, complexes were boiled in 25 μ L of sample buffer (Life Technologies) for 5 min. Proteins were separated

on NuPage 4-12% Bis-Tris gradient gels (Life Technologies) and transferred onto a PVDF membrane (GE Life Sciences). Membranes were blocked in TBS with 0.1% Tween-20 and 5% skim milk and blotted with the indicated primary antibody overnight at 4°C. Horseradish peroxidase conjugated secondary antibodies were detected using ECL plus western blotting detection system (Amersham). The following antibodies were used: α GFP (Clontech 632592), α HA clone 3F10 (Roche 11867431001) and α HA clone 12CA5 (a gift from Dr. Fred Dick).

3.2.4 Immunofluorescence microscopy and image analysis

Cells were fixed in 3.7% paraformaldehyde, permeabilized on ice using 0.2% Triton X-100 and blocked using 5% normal goat serum in PBS. Samples were incubated with primary antibody (α GFP) at room temperature for 1 h and for another hour at room temperature with secondary antibody (AlexaFluor-488 α Rabbit, Molecular Probes A-11008). Nuclei were stained with DAPI (ProLong Gold Anti-fade with DAPI, Life Technologies) Confocal images were acquired with a Fluoview 1000 laser scanning confocal microscope (Olympus Corp). Quantification of nuclear signal was conducted by determining the total cellular signal and the nuclear signal using ImageJ. Cells were normalized for both cytoplasmic and nuclear size and the % nuclear signal was determined as described previously (Magico and Bell, 2011). All numerical values represent means \pm S.E.M. from 25 cells for each sample. Statistical significance was calculated using one way ANOVA and a Tukey's HSD post-hoc comparison.

3.3 Results

3.3.1 The C-terminal E1A NLS requires both the major and minor binding groove of Qip1

Importin- α contains two NLS binding grooves, a major site located at the N-terminal Armadillo (Arm) repeat 2-4, and a minor site located at the Arm repeat 7-8. Classical monopartite NLSs specifically bind to the major binding site of Qip1, whereas bipartite NLSs bind to both sites (Conti et al. 1998; Dingwall and Laskey 1998). To determine which binding sites the C-terminal E1A NLS interacts with, we used Qip1 variants lacking the importin- β binding (IBB) domain, which is an autoinhibitory region, and

point mutants that specifically disrupt the major (Δ Major) or minor (Δ Minor) NLS binding sites, respectively (Conti et al. 1998; Dingwall and Laskey 1998; Lange et al. 2007). Human HT1080 fibrosarcoma cells were transfected with vectors co-expressing GFP fusions of the monopartite NLS from the SV40 T-Ag, the bipartite NLS from the nucleoplasmin protein (NP), or the second exon encoded portion of E1A (residues 187-289) and the panel of HA-tagged Qip1 constructs listed above. Lysates were immunoprecipitated using anti-HA antibodies (clone 12CA5) and subsequently immunoblotted for each GFP fusion (Figure 3.2). As expected, the monopartite T-Ag NLS failed to interact with Qip1 Δ Major (Figure 3.2A), while retained binding to Qip1 Δ Minor. The bipartite nucleoplasmin NLS was unable to interact with either Qip1 Δ Major or Δ Minor, as anticipated (Figure 3.2B). Like the bipartite nucleoplasmin NLS, the C-terminal E1A NLS failed to bind to either Qip1 mutant (Figure 3.2C). These results indicate that the C-terminal E1A NLS requires both the major and minor NLS binding sites of Qip1 to maintain its interaction, which is indicative of the presence of a bipartite NLS.

3.3.2 The C-terminal E1A bipartite NLS is comprised of residues 258-289

As noted above, there are highly conserved basic residues at K253, R258 and R262/263, which we predicted to be a part of the N-terminal portion of the bipartite NLS (Figure 3.1). To determine the minimal portion of E1A required for Qip1 binding, we created a series of C-terminal E1A truncation mutants that progressively delete these conserved basic residues (Figure 3.3A). To disrupt the number of basic residues in this region, we also engineered the same panel of truncations in combination with the R262/263E mutation, which we expected would abrogate Qip1 binding, as reported previously (Cohen et al. 2013). Lysates from cells co-expressing GFP fusions of the C-terminal region of E1A or our series of E1A truncations and HA-tagged Qip1 were immunoprecipitated using anti-HA antibodies and immunoblotted with anti-GFP antibodies (Figure 3.3B). As expected, an efficient interaction between Qip1 and the C-terminal region of E1A was observed. Furthermore, both the 253-289 and 258-289 truncations interacted with Qip1. However, the 262-289 truncation, which lacks part of

Figure 3.2 The C-terminus of E1A binds importin- α like a bipartite NLS

Human HT108 cells were co-transfected with vectors expressing GFP fused to: A) the monopartite NLS from SV40 Large-Tag (PKKKRKV), B) the bipartite nucleoplasmin NLS (KRPAATKKAGQAKKKK), or C) the C-terminal region of E1A (residues 187-289) along with the indicated HA-tagged Qip1 variants. Lysates were immunoprecipitated using anti-HA antibodies (12CA5) and immunoblotted using anti-GFP antibodies.

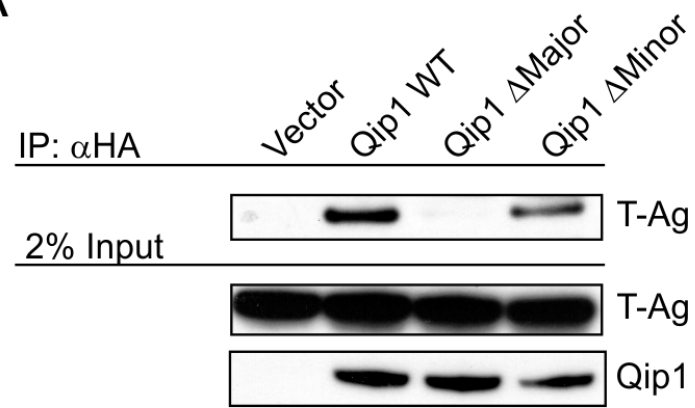
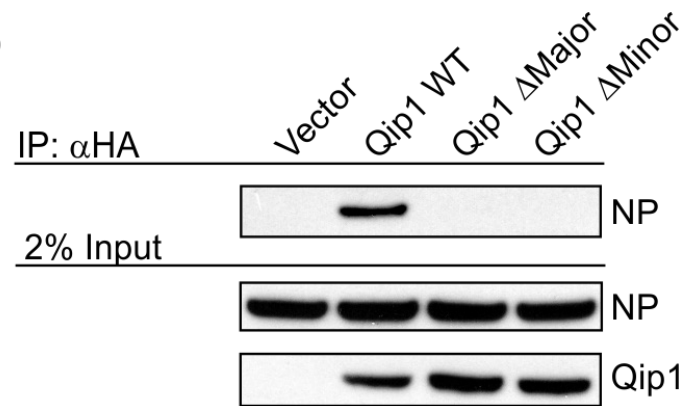
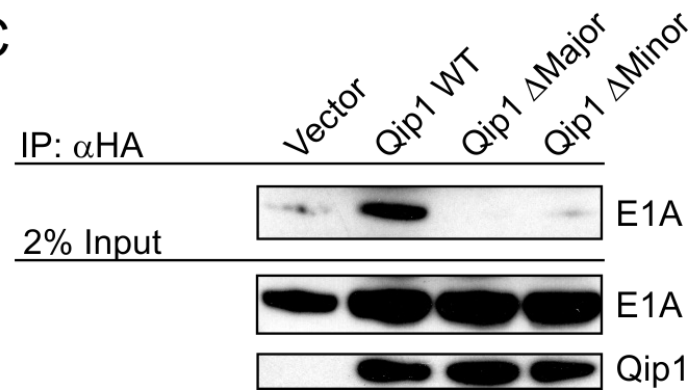
A**B****C**

the predicted bipartite NLS failed to bind. Unexpectedly, further truncation to only 282-289, which contains the previously identified C-terminal monopartite sequence, restored interaction with Qip1. We hypothesized that the interaction of the CtBP with E1A, which utilizes the PLDLS motif at the adjacent residues 279-283 (Schaeper et al. 1995; Chinnadurai 2002), interferes with and out-competes the binding of Qip1 in the context of the 262-289 truncation. To test this, we engineered a variant of the 262-289 mutant which also deletes the CtBP interaction motif (Δ PLDLS). Incorporation of this deletion restores Qip1 interaction (Figure 3.3C). Finally, we introduced the R262/263E point mutation into the various truncations, which abrogated their ability to interact with Qip1. These results indicate that E1A requires the cooperation of multiple basic residues beyond those present in the previously identified monopartite NLS for efficient binding (Figure 3.3B). Taken together, these results suggest that the minimal sequence required for Qip1 binding spans residues 258-289. This precisely coincides with the sequence predicted by the NLS prediction software cNLS-mapper (Kosugi et al. 2009).

3.3.3 The C-terminal bipartite NLS of E1A is sufficient for nuclear localization

To determine if the newly identified bipartite NLS is sufficient for nuclear transport, we investigated the subcellular localization of the GFP-E1A fusions described above using confocal fluorescence microscopy (Figure 3.4A). As expected, GFP fused to the entire C-terminal portion of E1A (187-289) localized exclusively to the nucleus. Both the 253-289 and 258-289 fragments exhibited similar localization phenotypes to that of WT E1A (Figure 3.4 left panel). While the 262-289 mutant did localize to the nucleus, it was not as efficient as the larger truncations and a substantial amount of signal was also observed in the cytoplasm. Furthermore, the 282-289 truncation was even more deficient for nuclear localization (Figure 3.4 left panel). Interestingly, the 262-289 Δ PLDLS mutant exhibited a similar localization phenotype to 282-289, analogous to the Qip1 interaction data shown above (Figure 3.3). As expected, substituting the basic amino acids at residues 262/263 abrogated nuclear localization (Figure 3.4 right panel), which coincided with the deficiency in Qip1 binding described above. Quantification of the nuclear signal is

Figure 3.3 Detailed mapping of the interaction of the C-terminus of E1A with importin- α

A) Schematic diagram of E1A truncation mutants. B) Human HT1080 cells were co-transfected with expression vectors for GFP fused to the C-terminal region of E1A (187-289) or the indicated E1A mutants and HA-tagged Qip1. Lysates were immunoprecipitated using anti-HA antibodies (12CA5) and immunoblotted using anti-GFP antibodies. Specific E1A truncations are denoted by their starting amino acid residue. The presence of the R262/263E mutation is indicated as EE mutation. C) The ability of the 262-289 fragment of E1A to bind Qip1 was tested in combination with deletion of the CtBP binding site PLDLS.

A



B

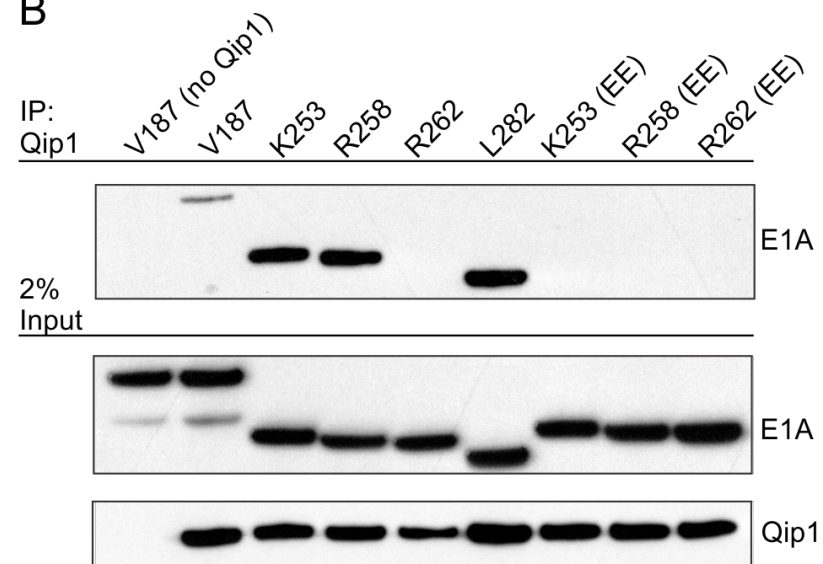

C

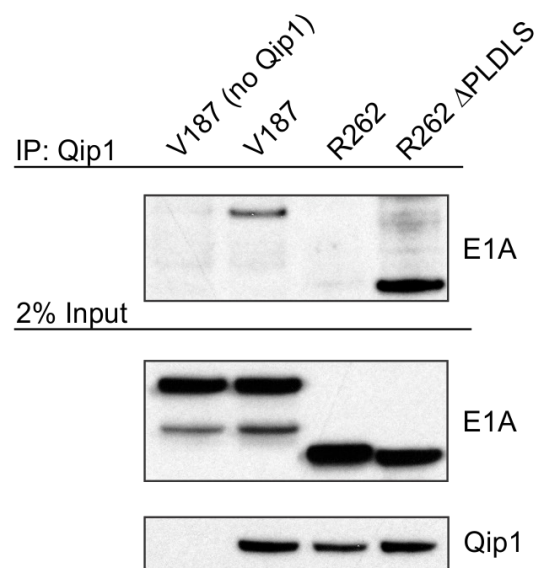

presented in Figure 3.4B, with statistically significant reductions observed in any E1A truncation with a nuclear/cytoplasmic phenotype. Overall, these results show that the C-terminal bipartite NLS of E1A is necessary and sufficient for efficient nuclear localization.

3.4 Discussion

Although nuclear import of E1A has been extensively studied, some aspects of the C-terminal NLS remain unknown. Although it is clear that the C-terminal pentapeptide sequence (²⁸⁵KRPRP²⁸⁹) is sufficient to confer nuclear localization in isolation (Lyons et al. 1987), it does not function in the same manner in the context of WT E1A. Indeed, multiple E1A mutants affecting residues upstream of the canonical monopartite NLS have been shown to exhibit a deficiency in nuclear localization (Douglas and Quinlan 1994; Douglas and Quinlan 1995; Cohen et al. 2013). These results suggest that while the signal is necessary for efficient nuclear localization, it is not wholly sufficient. As a mechanism to explain this, it was suggested that the mutations upstream of the extreme C-terminal KRPRP sequence may affect the conformation of E1A (Douglas and Quinlan 1996). In a recent study mapping interaction sites within the C-terminus of E1A, we recently pinpointed R262 and R263 as specific residues required to impair nuclear import and cause a nuclear/cytoplasmic localization phenotype (Cohen et al. 2013). Using an *in silico* prediction, these residues were predicted to comprise the N-terminal region of a putative bipartite NLS in E1A. In this study, we sought to test this prediction by characterizing the interaction of E1A with Qip1 in detail, and by further characterizing regions of E1A that are necessary and sufficient for nuclear localization.

The critical residues within the major and minor binding grooves of importin- α include highly conserved tryptophan and asparagine pairs that are in close proximity with the lysine and arginine side chains of a canonical NLS (Conti et al. 1998; Dingwall and Laskey 1998). Specifically for Qip1, these residues map to W179/N183 and W390/N394 for the major and minor binding groove, respectively (Conti et al. 1998). Using Qip1 variants with alanine point mutants at these sites, we observed that the C-terminus of E1A requires both the major and minor groove of Qip1 for binding to occur. This is indicative of a bipartite NLS, similar to that of the classical nucleoplasmin NLS used as a

Figure 3.4 Nuclear localization of C-terminal truncations of E1A

A) Human HeLa cervical carcinoma cells were transfected with expression vectors for GFP fusions of WT HAdV5 E1A or the indicated E1A truncation mutant and were subjected to confocal fluorescence microscopy. Nuclei were stained with DAPI. Specific E1A truncations are denoted by their starting amino acid residue. The right panel differs from the left panel in that the denoted truncation mutants also contain the R262/R263E mutation. B) Quantification of nuclear signal compared to total cellular signal. Statistically significant decreases in % nuclear signal from E1A 187-289 are indicated (* $P < 0.001$).

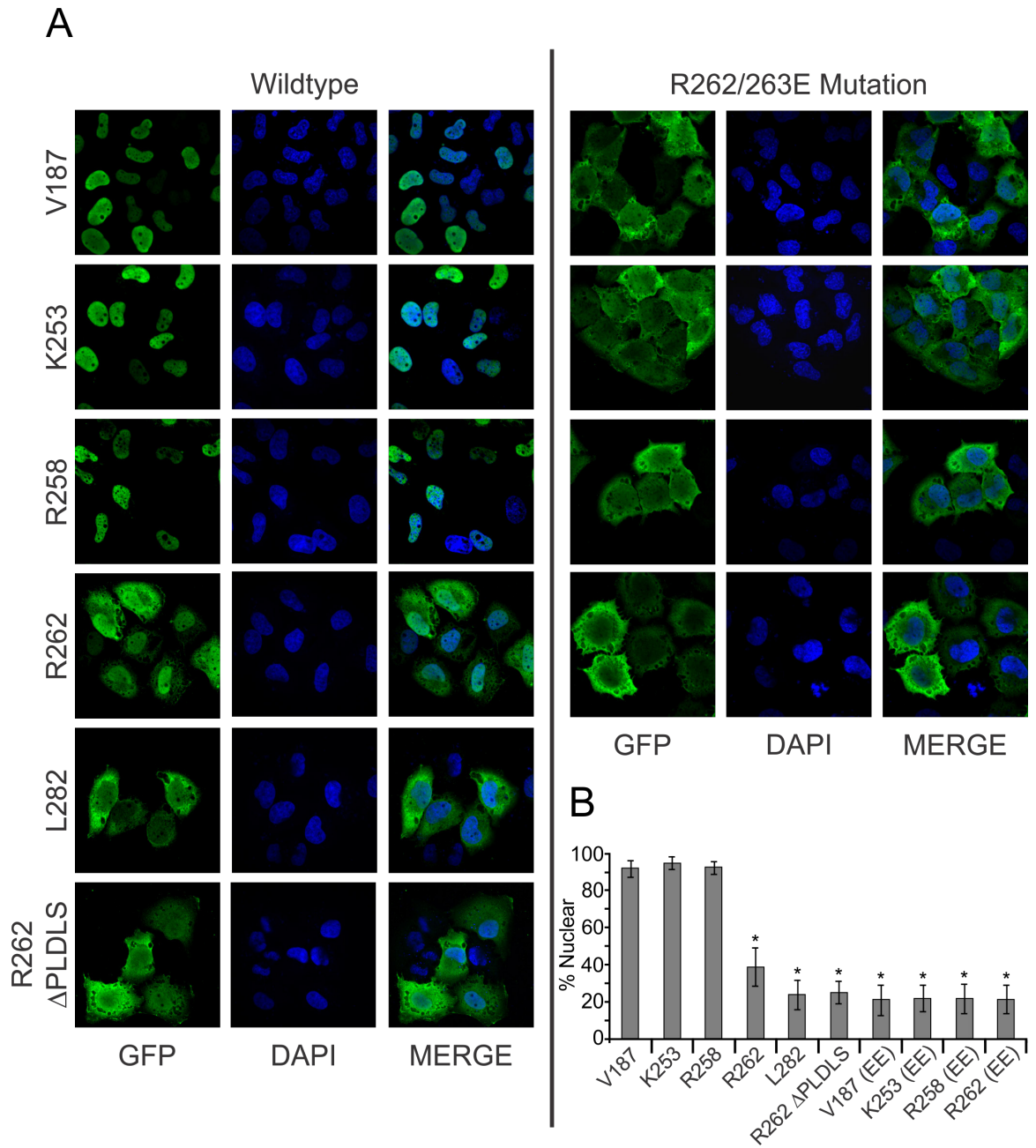

control in these experiments (Figure 3.2B-C). Using a panel of mutants that progressively truncate E1A at highly conserved basic residues (Figure 3.3A), we confirmed that a second patch of basic residues is essential for the interaction between E1A and Qip1, as point mutations that disrupt the net positive charge of this region abrogated binding (Figure 3.3B). Both 253- and 258-289 efficiently co-immunoprecipitated with Qip1, however the 262-289 truncation was completely deficient, suggesting that the minimum sequence required for this interaction is 258-289.

As a 262-289 truncation with a Δ PLDLS mutation recovered the Qip1 interaction (Figure 3.3C), we concluded that the CtBP interaction may outcompete Qip1 binding under the co-precipitation conditions. This seems highly likely, as the PLDLS and KRPRP motifs are separated by a single amino acid (Figure 3.1). This may explain why E1A mutants unable to bind to CtBP, or the KRPRP sequence in isolation can interact with Qip1 in the absence of the rest of the bipartite NLS (Figure 3.3B). However, using confocal fluorescence microscopy, we demonstrated that the full bipartite NLS (258-289) is necessary to cause the accumulation of GFP in the nucleus, whereas the previously characterized monopartite signal was not as efficient (Figure 3.4 left panel). This suggests that in the context of the *in vivo* nuclear localization experiments, competition by CtBP is less important. The evidence for a bipartite NLS is further strengthened by the observation that E1A-GFP fusions with the R262/263E mutations are deficient in nuclear targeting (Figure 3.4 right panel). Disruption of at least two of the four basic residues in this region appears to be necessary to abrogate nuclear localization as the E1A mutant R258E retains both full nuclear localization and Qip1 binding (Cohen et al. 2013). Thus, the bipartite signal remains functional despite the loss of an individual basic residue.

The C-terminal E1A NLS is one of the oldest documented sequences shown to confer nuclear import and was originally identified as a pentapeptide signal capable of translocating the cytoplasmic *Escherichia coli* protein GALK into the nucleus when fused to its C-terminus (Lyons et al. 1987). However, this fusion protein did not exhibit the full nuclear localization phenotype observed by full-length E1A. The results shown in this study reveal that the C-terminal pentamer is only a part of a much larger bipartite NLS in HAdV5 E1A, which contains a second cluster of basic residues and a 21 amino

acid linker region. By definition, a bipartite NLS includes a less-efficient monopartite NLS in its sequence (Robbins et al. 1991; Conti et al. 1998), therefore it is not surprising that this E1A NLS was misidentified as a monopartite NLS (Lyons et al. 1987). Furthermore, it has only recently been discovered that bipartite NLSs can contain a much larger linker region than the historically accepted 10-12 amino acids (Lange et al.). Therefore, older *in silico* prediction software such as PSORT II and PredictNLS were too restrictive and were likely unable to recognize the E1A bipartite NLS (Nakai and Horton 1999; Cokol et al. 2000). Interestingly, the E1A proteins of representative species A-G human adenoviruses invariantly contain basic residues at positions 253, 258, 262 and 263 in the upstream portion of the bipartite sequence, suggesting this is a highly conserved feature of the E1A proteins (Figure 3.1).

The majority of the interactions that the HAdV E1A protein makes in the infected cell occur in the nucleus, and as such, this viral protein encompasses a diverse array of mechanisms to ensure its nuclear localization (Pelka et al. 2008; Marshall et al. 2014). Why a viral protein would prefer a bipartite NLS over a monopartite NLS remains to be determined, although there is evidence to suggest that the presence of an upstream cluster of basic residues relaxes the stringent sequence requirements of monopartite signals. Specifically, nuclear import-deficient SV40 T-Ag mutants can be rescued by the addition of two basic amino acid residues 10 residues upstream of the defective NLS, effectively converting the signal into a functional bipartite NLS (Makkerh et al. 1996). Furthermore, studies examining the efficiency of non-viral gene transfer systems revealed that the bipartite NLS from the Ku70 protein improved the efficiency of transgene expression when compared to an array of monopartite NLSs (Matschke et al. 2012). Thus, E1A may benefit from a bipartite NLS through more stable and efficient transport to the nucleus.

3.5 References

- Avvakumov, N., A. E. Kajan, R. C. Hoeben and J. S. Mymryk (2004). "Comprehensive sequence analysis of the E1A proteins of human and simian adenoviruses." Virology **329**(2): 477-92.
- Avvakumov, N., M. Sahbegovic, Z. Zhang, M. Shuen and J. S. Mymryk (2002). "Analysis of DNA binding by the adenovirus type 5 E1A oncoprotein." J Gen Virol **83**(Pt 3): 517-24.
- Bayley, S. and J. Mymryk (1994). "Adenovirus e1a proteins and transformation (review)." Int J Oncol **5**(3): 425-44.
- Chinnadurai, G. (2002). "CtBP, an unconventional transcriptional corepressor in development and oncogenesis." Mol Cell **9**(2): 213-24.
- Cohen, M. J., A. F. Yousef, P. Massimi, G. J. Fonseca, B. Todorovic, P. Pelka, A. S. Turnell, L. Banks and J. S. Mymryk (2013). "Dissection of the C-terminal region of E1A redefines the roles of CtBP and other cellular targets in oncogenic transformation." J Virol **87**(18): 10348-55.
- Cokol, M., R. Nair and B. Rost (2000). "Finding nuclear localization signals." EMBO Rep **1**(5): 411-5.
- Conti, E., M. Uy, L. Leighton, G. Blobel and J. Kuriyan (1998). "Crystallographic analysis of the recognition of a nuclear localization signal by the nuclear import factor karyopherin alpha." Cell **94**(2): 193-204.
- Dingwall, C. and R. A. Laskey (1998). "Nuclear import: a tale of two sites." Curr Biol **8**(25): R922-4.
- Dingwall, C., J. Robbins, S. M. Dilworth, B. Roberts and W. D. Richardson (1988). "The nucleoplasmin nuclear location sequence is larger and more complex than that of SV-40 large T antigen." J Cell Biol **107**(3): 841-9.
- Douglas, J. L. and M. P. Quinlan (1994). "Efficient nuclear localization of the Ad5 E1A 12S protein is necessary for immortalization but not cotransformation of primary epithelial cells." Cell Growth Differ **5**(5): 475-83.
- Douglas, J. L. and M. P. Quinlan (1995). "Efficient nuclear localization and immortalizing ability, two functions dependent on the adenovirus type 5 (Ad5) E1A second exon, are necessary for cotransformation with Ad5 E1B but not with T24ras." J Virol **69**(12): 8061-5.

- Douglas, J. L. and M. P. Quinlan (1996). "Structural limitations of the Ad5 E1A 12S nuclear localization signal." Virology **220**(2): 339-49.
- Ferrari, R., A. J. Berk and S. K. Kurdistani (2009). "Viral manipulation of the host epigenome for oncogenic transformation." Nat Rev Genet **10**(5): 290-4.
- Ferrari, R., M. Pellegrini, G. A. Horwitz, W. Xie, A. J. Berk and S. K. Kurdistani (2008). "Epigenetic reprogramming by adenovirus e1a." Science **321**(5892): 1086-8.
- Flint, J. and T. Shenk (1997). "Viral transactivating proteins." Annu Rev Genet **31**: 177-212.
- Fonseca, G. J., G. Thillainadesan, A. F. Yousef, J. N. Ablack, K. L. Mossman, J. Torchia and J. S. Mymryk (2012). "Adenovirus evasion of interferon-mediated innate immunity by direct antagonism of a cellular histone posttranslational modification." Cell Host Microbe **11**(6): 597-606.
- Kalderon, D., B. L. Roberts, W. D. Richardson and A. E. Smith (1984). "A short amino acid sequence able to specify nuclear location." Cell **39**(3 Pt 2): 499-509.
- Kohler, M., D. Gorlich, E. Hartmann and J. Franke (2001). "Adenoviral E1A protein nuclear import is preferentially mediated by importin alpha3 in vitro." Virology **289**(2): 186-91.
- Kosugi, S., M. Hasebe, M. Tomita and H. Yanagawa (2009). "Systematic identification of cell cycle-dependent yeast nucleocytoplasmic shuttling proteins by prediction of composite motifs." Proc Natl Acad Sci U S A **106**(25): 10171-6.
- Lange, A., L. M. McLane, R. E. Mills, S. E. Devine and A. H. Corbett (2010). "Expanding the definition of the classical bipartite nuclear localization signal." Traffic **11**(3): 311-23.
- Lange, A., R. E. Mills, C. J. Lange, M. Stewart, S. E. Devine and A. H. Corbett (2007). "Classical nuclear localization signals: definition, function, and interaction with importin alpha." J Biol Chem **282**(8): 5101-5.
- Lyons, R. H., B. Q. Ferguson and M. Rosenberg (1987). "Pentapeptide nuclear localization signal in adenovirus E1a." Mol Cell Biol **7**(7): 2451-6.
- Macara, I. G. (2001). "Transport into and out of the nucleus." Microbiol Mol Biol Rev **65**(4): 570-94, table of contents.

- Madison, D. L., P. Yaciuk, R. P. Kwok and J. R. Lundblad (2002). "Acetylation of the adenovirus-transforming protein E1A determines nuclear localization by disrupting association with importin- α ." *J Biol Chem* **277**(41): 38755-63.
- Magico, A. C. and J. B. Bell (2011). "Identification of a classical bipartite nuclear localization signal in the Drosophila TEA/ATTS protein scalloped." *PLoS One* **6**(6): e21431.
- Makkerh, J. P., C. Dingwall and R. A. Laskey (1996). "Comparative mutagenesis of nuclear localization signals reveals the importance of neutral and acidic amino acids." *Curr Biol* **6**(8): 1025-7.
- Marshall, K. S., M. J. Cohen, G. J. Fonseca, B. Todorovic, C. R. King, A. F. Yousef, Z. Zhang and J. S. Mymryk (2014). "Identification and characterization of multiple conserved nuclear localization signals within adenovirus E1A." *Virology* **454-455**: 206-14.
- Matschke, J., A. Bohla, C. Maucksch, R. Mittal, C. Rudolph and J. Rosenecker (2012). "Characterization of Ku70(2)-NLS as bipartite nuclear localization sequence for non-viral gene delivery." *PLoS One* **7**(2): e24615.
- Nakai, K. and P. Horton (1999). "PSORT: a program for detecting sorting signals in proteins and predicting their subcellular localization." *Trends Biochem Sci* **24**(1): 34-6.
- Okazaki, K., N. Nakayama, Y. Nariai, K. Nakayama, K. Miyazaki, R. Maruyama, H. Kato, S. Kosugi, T. Urano and G. Sakashita "Nuclear localization signal in a cancer-related transcriptional regulator protein NAC1." *Carcinogenesis* **33**(10): 1854-62.
- Pelka, P., J. N. Ablack, G. J. Fonseca, A. F. Yousef and J. S. Mymryk (2008). "Intrinsic structural disorder in adenovirus E1A: a viral molecular hub linking multiple diverse processes." *J Virol* **82**(15): 7252-63.
- Robbins, J., S. M. Dilworth, R. A. Laskey and C. Dingwall (1991). "Two interdependent basic domains in nucleoplasmin nuclear targeting sequence: identification of a class of bipartite nuclear targeting sequence." *Cell* **64**(3): 615-23.
- Schaeper, U., J. M. Boyd, S. Verma, E. Uhlmann, T. Subramanian and G. Chinnadurai (1995). "Molecular cloning and characterization of a cellular phosphoprotein that interacts with a conserved C-terminal domain of adenovirus E1A involved in negative modulation of oncogenic transformation." *Proc Natl Acad Sci U S A* **92**(23): 10467-71.

Slavicek, J. M., N. C. Jones and J. D. Richter (1989). "A karyophilic signal sequence in adenovirus type 5 E1A is functional in *Xenopus* oocytes but not in somatic cells." J Virol **63**(9): 4047-50.

Standiford, D. M. and J. D. Richter (1992). "Analysis of a developmentally regulated nuclear localization signal in *Xenopus*." J Cell Biol **118**(5): 991-1002.

Chapter 4

4 Investigating the functional mechanism by which the cellular targets of the C-terminal region of E1A modulate E1A-dependent transformation

4.1 Introduction

Human adenovirus E1A makes extensive connections with the cellular protein interaction network. By doing so, E1A can manipulate many cellular programs, including cell cycle progression. Through these reprogramming events, E1A function as a growth promoting oncogene and has been used extensively to investigate mechanisms contributing to oncogenesis (Bayley and Mymryk 1994; Mymryk 1996; Flint and Shenk 1997). Nevertheless, it remains unclear how the C-terminal region of E1A contributes to oncogenic transformation. Although this region of E1A is required for transformation in cooperation with E1B, it paradoxically suppresses transformation in cooperation with activated Ras. As described in Chapter 2 of this thesis, we identified key residues that are specifically required for binding all known targets of the C-terminus of E1A. We further tested each E1A mutant for their ability to both localize to the nucleus and transform primary rat cells in cooperation with E1B or Ras. Interaction of E1A with importin- α /Qip1, DYRK1A, HAN11 and CtBP influenced transformation in cooperation with E1B. Interestingly, the interaction of E1A with DYRK1A and HAN11 appeared to be required to suppress transformation by activated Ras, whereas interaction with CtBP was not necessary. This unexpected result necessitates a revision of the current models of E1A-mediated transformation (Figure 4.1).

This chapter describes an ongoing investigation in understanding the mechanisms by which DYRK1A, HAN11, FOXK1 and CtBP mediates oncogenic transformation by E1A. Each of the cellular targets that the C-terminus of E1A binds to play important roles in many cellular processes that may be involved in oncogenic transformation and tumourigenesis, including survival, differentiation, cell-cycle control, DNA damage repair, and cell migration. Furthermore, these targets can act as molecular hubs, thereby opening a window of opportunity for E1A to control additional layers of proteins via

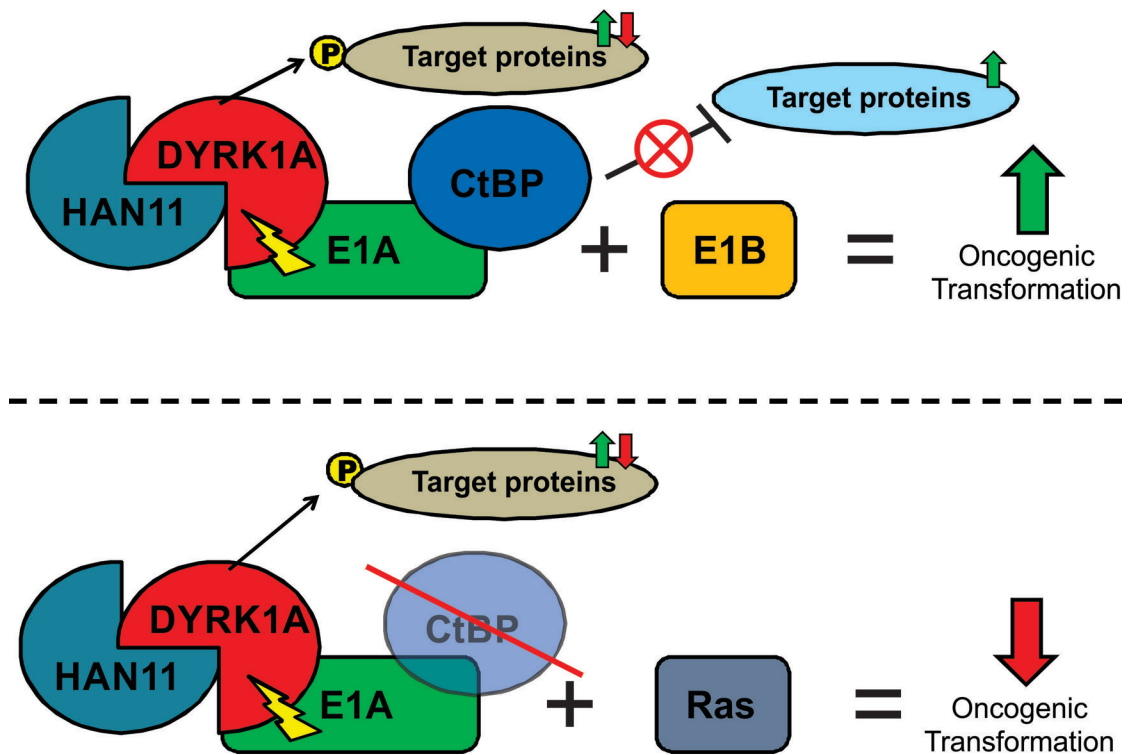

Figure 4.1 Proposed model of E1A-mediated oncogenic transformation

Past studies indicated that CtBP plays a critical role in E1A-mediated oncogenic transformation with both E1A and Ras. Our analysis described in Chapter 2 of this thesis identified that DYRK1A, HAN11, and CtBP influence E1A-mediated transformation in cooperation with E1B-55K, however, the CtBP interaction was not necessary for E1A-mediated suppression of transformation with activated Ras. As E1A stimulates the kinase activity of DYRK1A and competes for binding with cellular CtBP target proteins, we hypothesized that E1A may alter the expression and/or function of downstream targets of these C-terminal interacting proteins, which contributes to oncogenic transformation.

these secondary interactions and induce major changes to in cellular regulation. Specifically, E1A has been shown to stimulate the kinase activity of DYRK1A (Zhang et al. 2001), and therefore HAdV infection may enhance or inhibit the molecular functions of DYRK targets. Furthermore, E1A competes with cellular proteins containing PXLDSL motifs thereby de-repressing the genes regulated by CtBP that may be involved growth, tumorigenesis, and apoptosis (Frisch and Mymryk 2002; Pelka et al. 2008; Chinnadurai 2009). We therefore hypothesize that E1A utilizes DYRK1A, HAN11, CtBP, and/or FOXK1 to mediate oncogenic transformation by altering transcription of their downstream target genes (Figure 4.1).

To address this hypothesis, we constructed two novel genomic HAdVs with mutations in E1A that specifically disrupt the interactions between DYRK1A/HAN11 and CtBP (R262/263E and Δ PLDLS, respectively) and utilized a previously generated HAdV mutant that specifically inhibits FOXK1/2 binding (dl1132) (Mymryk and Bayley 1993). We performed next generation RNAseq on growth-arrested human IRM90 primary fibroblasts to investigate the global changes in gene expression between cells infected with a wildtype virus and this panel of HAdV mutants. RNAseq has become a revolutionary tool for whole transcriptome profiling (Wang et al. 2009) and furthermore, this strategy has recently been successfully used to discover how the interactions between E1A and Rb or p300 influence cellular gene expression (Ferrari et al. 2014).

A preliminary overview of this large dataset is presented in this chapter. Importantly, the R262/263E HAdV, which fails to interact with DYRK1A/1B or HAN11, was shown to have the largest number of differentially expressed (DE) genes when compared to wildtype HAdV, with over 6000 genes having a ≥ 2 fold change in the number of sequencing reads. We observed that a cluster of downregulated genes in the R262/263E infected cells corresponded to pathways in cancer and the regulation of apoptosis. Furthermore, cell death was observed *in vivo* by measurement of terminal deoxynucleotidyl transferase-mediated dUTP nick end labeling (TUNEL). These preliminary results may indicate that DYRK1A and HAN11 aid in E1A-mediated transformation by promoting survival and inhibiting apoptosis.

4.2 Materials and Methods

4.2.1 Cells and viruses

Human embryonic kidney 293 (HEK293), HT1080, HeLa, and IMR-90 cells were originally obtained from the American Type Culture Collection (ATCC). dl309 (expresses wildtype E1A) (Jones and Shenk 1979), dl312 (does not express E1A) (Jones and Shenk 1979), and dl1132 (Mymryk and Bayley 1993) were described previously. R262/263E and Δ PLDLS viruses were constructed by cloning the respective mutant E1A sequences into the pXC1 adenovirus shuttle vector (a generous gift from F. Graham). Recombinant virus was rescued by transfecting 5 μ g of pXC-R262/263E or pXC- Δ PLDLS into HEK293 cells along with 10 μ g of the pJM17 recombinant adenovirus backbone vector, using a 1:14 DNA-to-Superfect (Qiagen) ratio. Virus was then plaque purified and screened by sequencing of viral DNA. All cells were propagated in DMEM (Wisent) supplemented with 10% FBS, 100U/mL penicillin, and 100 μ g/mL streptomycin (Wisent). Viruses were grown on HEK293 cells and were purified using a cesium chloride gradient as described previously (Tollefson et al. 2007).

4.2.2 Cell infections

HT1080 cells were infected at a multiplicity of infection (MOI) of 5 and were incubated at 37°C in 5% CO₂ for 1h to permit adsorption. Cells were washed with PBS and were re-incubated with fresh medium. Cells were collected 24 hours post infection (hpi) for co-immunoprecipitation experiments. IMR-90 cells were seeded in 60mm dishes or on glass coverslips and were grown for 3 days after reaching confluence to establish contact inhibition. Cells were infected at an MOI of 25 and were incubated for 1h as described above. Cells were harvested 40hpi for RNA extraction or TUNEL analysis.

4.2.3 Western blotting and co-immunoprecipitations

Cells were lysed with NP40 lysis buffer and protein concentrations were determined with BioRad protein assay reagent using BSA as a standard. 0.5 mg of protein lysate was immunoprecipitated with the indicated antibodies at 4°C for 4 hours. 10 μ g of protein was kept as 1% input. After 3 washes in NP40 lysis buffer, complexes were boiled in 25

μL of sample buffer (Life Technologies) for 5 min. Proteins were separated on NuPage 4-12% Bis-Tris gradient gels (Life Technologies) and transferred onto PVDF membranes (GE Life Sciences). Membranes were blocked in TBS with 0.1% Tween-20 and 5% skim milk and blotted with the indicated primary overnight at 4°C. Horseradish peroxidase conjugated secondary antibodies were detected using ECL plus western blotting detection system (Amersham). The following antibodies were used: αE1A clone M58 and M37 (in house hybridoma supernatants), αCtBP1 (BD Biosciences 612042), and αDYRK1A clone 7D10 (Sigma-Aldrich).

4.2.4 mRNA isolation and PCR

Total RNA was isolated using TRIzol reagent (Life Technologies). Contaminating viral DNA was eliminated by DNase I treatment (Life Technologies) according to the manufacturer's instructions. One μg of total RNA was subjected to first-strand cDNA synthesis using qScript cDNA Supermix (Quanta Biosciences). Conventional PCR was conducted using Phusion DNA polymerase (Fisher Biosciences). E1A was amplified using the forward primer (5'-GTGTCTGAACCTGAGCCTGAG-3') and reverse primer (5'-TTATGGCCTGGGGCGTTTACA-3').

4.2.5 High-throughput sequencing

Library preparation from total RNA and high-throughput sequencing was performed on Illumina Genome Analyzers (HiSeq 2500) according to the manufacturer's protocols (Illumina) at the University of California San Diego (UCSD) Genomics Centre. The sequences returned by the Illumina Pipeline were aligned to the human hg19 reference genome (genome reference consortium human build 37) using the ELAND software.

4.2.6 Data analysis

Downstream data analysis including normalization of sequencing reads and significant changes in gene expression was performed using HOMER, a software suite for RNAseq analysis (Heinz et al. 2010). Gene clustering and heat map generation was conducted using the Cluster 3.0 and Java Tree View software, respectively (de Hoon et al. 2004; Saldanha 2004). Functional annotation and Gene Ontology (GO) Enrichment analysis

was conducted using the Database for Annotation, Visualization, and Integrated Discovery (DAVID) website (Huang da et al. 2009; Huang da et al. 2009) and the online software iPathway Guide (Advaita Inc.).

4.2.7 Confocal immunofluorescence microscopy and TUNEL assay

Apoptotic cell injury was assessed by TUNEL (In-Situ Cell Death Kit, Roche) Cells were fixed in 3.7% formaldehyde in PBS for 20 min. Slides were washed with 1% PBS three times and then permeabilized on ice using 0.2% Triton X-100 for 15 minutes. After additional washes, cells were treated with the TUNEL enzyme solution according to manufacturer's guidelines. As a negative control, TUNEL enzyme was omitted for some wells. As a positive control, some wells were treated with DNase I. Following TUNEL staining, samples were incubated with primary antibody (α E1A clone M58) at room temperature for one hour and for another hour at room temperature with secondary antibody (AlaxaFluor-594 α Mouse, Molecular Probes). Nuclei were stained with DAPI (Life Technologies). Confocal images were acquired with a Fluoview 1000 laser scanning confocal microscope (Olympus Corp.).

4.3 Results

4.3.1 Generation of two novel HAdV mutants to disrupt the DYRK1A/HAN11 and CtBP interactions

Previously generated HAdV mutants, especially dl1135, which deletes residues 271-284 (Boyd et al. 1993), abrogate the interaction of E1A with multiple cellular targets. Therefore, to study the consequences of loss of interaction with each individual target of the C-terminus of E1A in the context of adenovirus infection, we generated two novel genomic HAdV viruses with mutations at key residues in E1A that were shown to disrupt the DYRK1A/HAN11 interactions and the CtBP interaction based on previous analysis (R262/263E and Δ PLDLS, respectively). Human HT1080 fibrosarcoma cells infected with wildtype HAdV (dl309), a mutant lacking E1A (dl312), the R262/263E mutant, or the Δ PLDLS mutant were harvested 24hpi. Lysates were immunoprecipitated using anti-E1A antibodies (clone M58 and M37) and subsequently immunoblotted for DYRK1A

and CtBP (Figure 4.2A). As expected, DYRK1A and CtBP coprecipitated with E1A in cells infected with dl309, but not with dl312. However, the R262/263E showed a complete abrogation for DYRK1A binding, while retaining the ability to interact with CtBP. Conversely, the Δ PLDLS virus failed to interact with CtBP but could pull down DYRK1A. Overall, these results indicate that the novel HAdV mutants are appropriate tools for individually studying the downstream consequences of the DYRK1A and CtBP interactions in the context of HAdV infection.

4.3.2 Cellular mRNA expression alterations mediated by the C-terminal interactions of E1A

Contact-inhibited IMR-90 cells arrested in G1 were mock infected, infected with dl312, dl309, the dl1132 mutant that fails to interact with FOXK1/2 (Komorek et al. 2010; Cohen et al. 2013), R262/263E, or Δ PLDLS at an MOI of 25. As the kinetics of infection for growth-arrested IMR-90 cells is typically twice as long as that of HeLa or A549 cell infection (Granberg et al. 2006), we harvested these cells 40 hpi for RNA extraction. Reverse-transcription PCR (RT-PCR) was carried out to ensure appropriate expression of E1A for each virus (Figure 4.2B). Total RNA samples from infected cells were sent to the UCSD Genomics Centre for library construction and RNAseq. Reads were aligned to the hg19 human reference genome and normalized read counts as well as differential expression profiles were analyzed using the HOMER RNAseq software (Heinz et al. 2010).

Hierarchical clustering of genes normalized by Reads Per Kilobase of transcript per Million mapped reads (RPKM) was conducted using the Cluster 3.0 program (de Hoon et al. 2004) and visualized using Java Tree View (Saldanha 2004) (Figure 4.3). The gene expression profile of Mock, dl312 and dl1132 were closely related while dl309, R262/263E, and Δ PLDLS clustered together. Interestingly, the DYRK1A/HAN11 interaction appeared to control expression of the highest number of genes, as illustrated by the largest degree of atypical expression in the R262/263E sample. Although numerous small gene clusters were identified, the broadest three clusters are highlighted in Figure 4.3. The list of genes in these clusters were subjected to enrichment analysis using DAVID to identify GO terms over-represented in each cluster. GO terms with

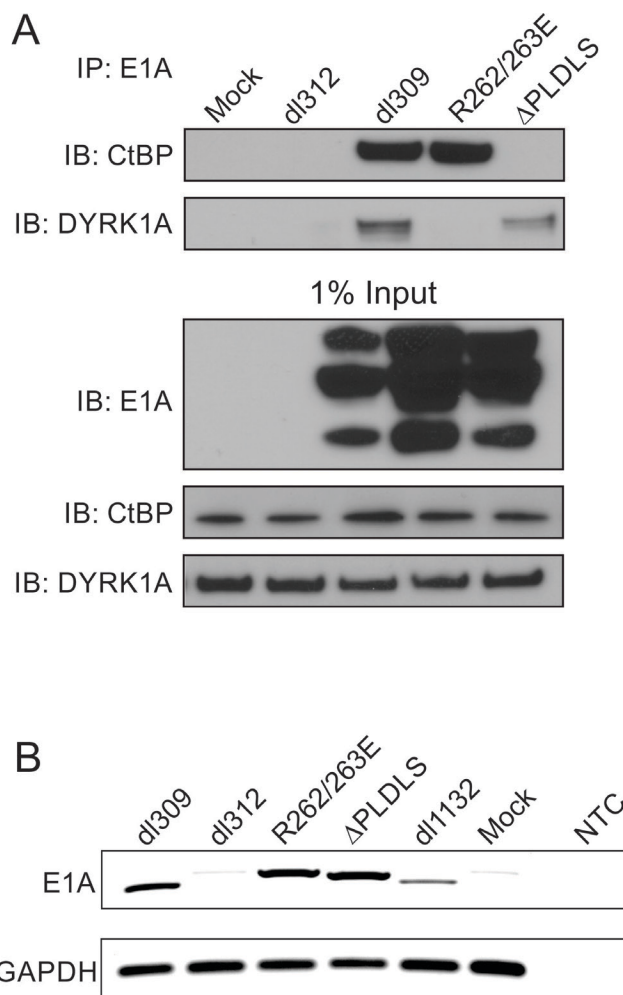

Figure 4.2 Verification of endogenous DYRK1A or CtBP interactions and expression of E1A

A) Human HT1080 cells were mock-infected, or infected with wildtype HAdV (dl309), a Δ E1A virus (dl312), or novel HAdVs harboring E1A mutants R262/263E or Δ PLDLS, respectively. Lysates were immunoprecipitated using anti-E1A antibodies and immunoblotted for endogenous CtBP or DYRK1A. B) Contact-inhibited IMR-90 cells were mock-infected, or infected with wildtype HAdV (dl309), Δ E1A (dl312), or mutants that are unable to bind DYRK1A/B (R262/263E), CtBP1/2 (Δ PLDLS), or FOXK1/2 (dl1132) and were harvested 40hpi for RNA extraction. RT-PCR for E1A was performed to ensure proper expression before RNAseq analysis. NTC = No Template Control. Amplification of GAPDH was used as a loading control.

P-values less than .0001 were considered to be significant. The top-most gene cluster associated with a variety of terms, including the regulation of cell proliferation, the regulation of apoptosis, and pathways in cancer. Importantly, the expression profile of cells infected with the R262/263E virus exhibited a large downregulation in this gene cluster as indicated in the heatmap (Figure 4.3). The middle gene cluster associated with pathways involved in cell cycle, chromosome organization and DNA replication. Wildtype HAdV appeared to have the largest number of activated genes in this cluster. Finally, the bottom-most gene cluster was related to genes involved in processes including ribosome activity, translation, apoptosis, and cell death, with a significant number of genes being upregulated during HAdV R262/263E infection.

4.3.3 Differential expression profile of wildtype HAdV vs C-terminal mutants

We next looked at the differential expression profile of cells infected with the C-terminal HAdV mutants relative to wildtype infection. Differential expression was calculated using the HOMER RNAseq analysis software and the log₂ fold change for each comparison was submitted to the online bioinformatics tool, iPathwayGuide. A summary of the number of significantly DE genes for each condition is depicted graphically in Figure 4.4. Genes were considered if they met a threshold of 0.05 for statistical significance and 1 for absolute log expression change (2-fold change) from a total of 17586 genes with measured expression. Infection with dl1132 resulted in 1586 DE genes compared to dl309 (Figure 4.4C). The R262/263E HAdV was shown to have the largest number of DE genes with 6420 selected (Figure 4.4D), while infection with Δ PLDLS lead to the smallest number, at 839 DE genes (Figure 4.4E). dl309 vs Mock infection and dl309 vs dl312 infection resulted in 2839 and 3963 DE genes, respectively (Figure 4.4A and B). We also created Venn diagrams to observe overlap between the DE genes mediated by FO XK1/2, DYRK1A/HAN11, or CtBP, and mock or Δ E1A infections (Figure 4.5). The FO XK1/2 interaction appeared to result in 116 unique DE genes (Figure 4.5A), DYRK1A/HAN11 interaction mediates differential expression of 5021 unique genes (Figure 4.5B), and CtBP binding leads to 352 unique DE genes (Figure 4.5C).

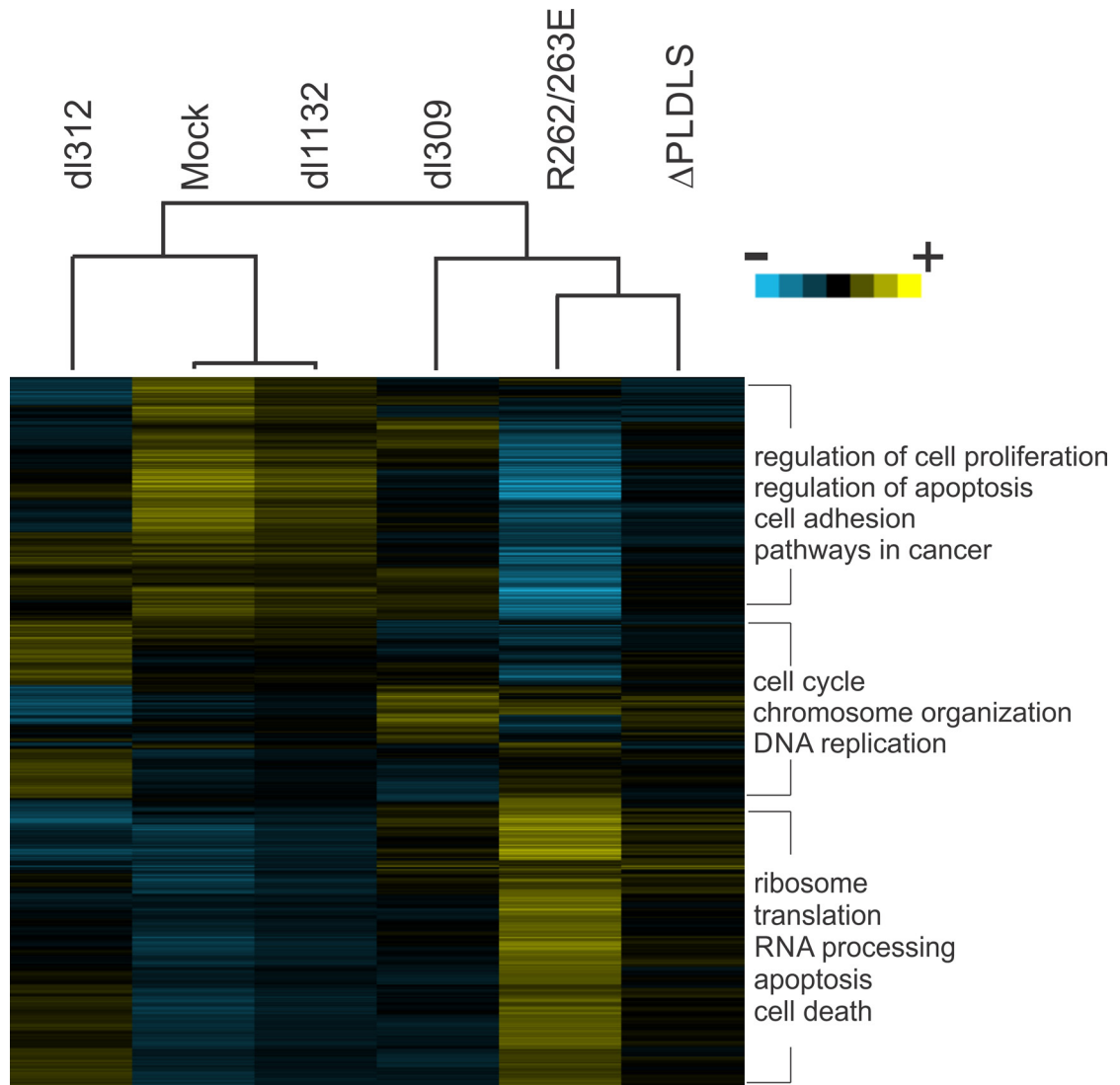
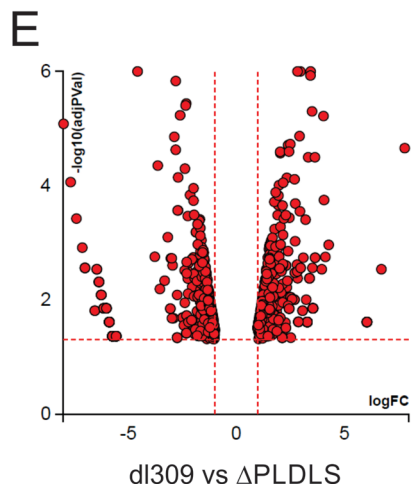
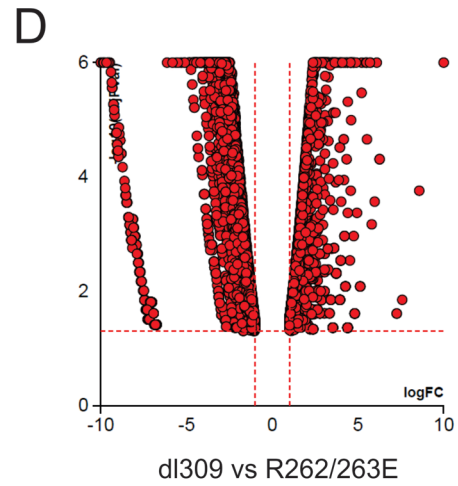
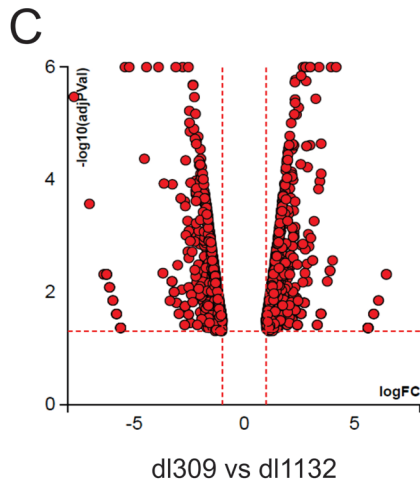
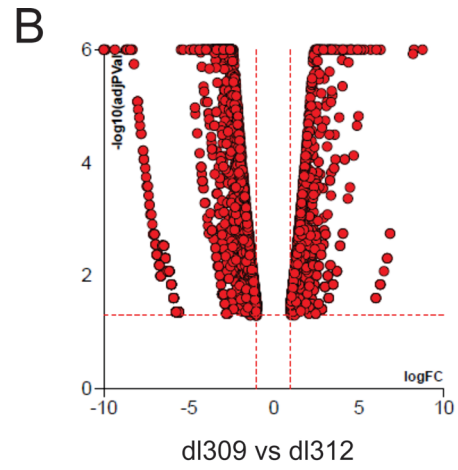
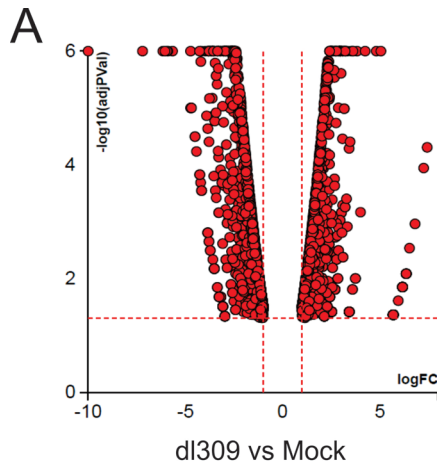

Figure 4.3 Host cell gene expression regulated by the C-terminal targets of E1A

Heat map of RNA increased (yellow) or decreased (blue) from cells infected with the indicated HAdV. RNAseq reads normalized before hierarchical clustering by the Cluster 3.0 software and visualization using the Java Tree View program. Noteworthy GO terms and KEGG pathways are listed for the three broad gene clusters.

Figure 4.4 Differential gene expression between wildtype HAdV and viral mutants unable to interact with FOXK1, DYRK1A/HAN11, or CtBP

A-E) Volcano plots of significantly DE genes for each condition, represented in terms of their measured expression change (horizontal) and the significance of their change (vertical). The significance is represented in terms of the negative log of the p-value (i.e., larger number means more significant). The dotted lines represent the threshold used to select the DE genes: \log_2 of 1 for expression change, and .05 for significance. F) Summary of the total number of DE genes for each experimental condition.



F

Condition	# of DE Genes
dl309 vs Mock	2839
dl309 vs dl312	3963
dl309 vs dl1132	1586
dl309 vs R262/263E	6420
dl309 vs Δ PLDLS	839

We also analyzed this differential gene expression dataset in the context of pathways obtained from the Kyoto Encyclopedia of Genes and Genomes (KEGG) (Kanehisa and Goto 2000; Kanehisa et al. 2002) and gene ontology from the Gene Ontology Consortium database (Ashburner et al. 2000). KEGG pathways and GO terms with P-values less than .0001 were considered. In total, 47 pathways were found to be significantly impacted and 1696 GO terms were significantly enriched for dl309 vs dl1132. For dl309 vs R262/623E, 82 pathways and 1518 GO terms were identified. Finally, for dl309 vs Δ PLDLS, 27 pathways and 1094 GO terms were significantly impacted. Control comparisons revealed 43 pathways and 1622 and GO terms for dl309 vs Mock infected, and 48 pathways and 1022 GO terms for dl309 vs dl312 as significantly enriched.

A list of high-confidence KEGG pathways and GO terms are shown in Table 4.1. Hits for dl309 vs Mock, dl309 vs 312, and dl309 vs 1132 revealed similar results and included pathways such as DNA replication, mismatch repair, and biological functions such as cell cycle and nuclear division. This similarity corresponded with the general gene expression clustering observed in Figure 4.3. In cells infected with an HAdV deficient for DYRK1A and HAN11 binding, some pathways impacted included ribosome function, transcriptional misregulation in cancer, and apoptosis. Interestingly, the FoxO signalling pathway, which has been shown to be regulated by DYRK1A (Woods et al. 2001) was also significantly affected. Additionally, viral transcription, regulation of transcription, and regulation of cell death were among the top biological processes enriched by GO analysis for the dl309 vs R262/263E comparison. Finally analysis of the dl309 vs Δ PLDLS comparison showed that a deficiency in CtBP binding impacted pathways such as NF-kappa B signalling, ribosome function, and transcriptional misregulation in cancer. Enriched GO terms included type I interferon signalling pathways, regulation of viral genome replication, regulation of cell division, cell adhesion, and the inflammatory response.

4.3.4 The HAdV R262/263E mutant induces apoptosis

A common theme throughout the preliminary analysis of this large dataset was that abrogation of DYRK1A and HAN11 binding, via the R262/263E HAdV mutant, resulted in the most prevalent alterations in gene expression. Furthermore, the regulation of cell

Table 4-1 List of significantly impacted KEGG pathway and GO terms based on DE genes between cells infected with wildtype or mutant HAdVs

Condition	KEGG Pathways	Gene Ontology Terms
dl309 vs Mock	<ul style="list-style-type: none"> - DNA replication - Mismatch repair - ECM-receptor interaction - Small cell lung cancer - Base excision repair 	<ul style="list-style-type: none"> - Cell cycle - Mitotic cell cycle - DNA metabolic process - Cell cycle process - Nuclear division
dl309 vs dl312	<ul style="list-style-type: none"> - DNA replication - Mismatch repair - Metabolism of xenobiotics - Fanconi anemia pathway - Cell cycle 	<ul style="list-style-type: none"> - Cell cycle - Mitotic cell cycle - Mitotic cell cycle process - Nuclear division - Organelle fission
dl309 vs dl1132	<ul style="list-style-type: none"> - DNA replication - Mismatch repair - Cell cycle - Fanconi anemia pathway - Base excision repair 	<ul style="list-style-type: none"> - Cell cycle - Mitotic cell cycle - Nuclear division - Organelle fission - Cell division
dl309 vs R262/263E	<ul style="list-style-type: none"> - Ribosome - Transcriptional misregulation in cancer - Apoptosis - Jak-STAT signalling pathway - FoxO signaling pathway 	<ul style="list-style-type: none"> - Viral transcription - Translational termination - Regulation of transcription - Protein targeting to membrane - Regulation of cell death
dl309 vs Δ PLDLS	<ul style="list-style-type: none"> - NF-kappa B signalling pathway - Ribosome - Taste transduction - Transcriptional misregulation in cancer - Cell adhesion molecules (CAMs) 	<ul style="list-style-type: none"> - Type I interferon signalling pathway - Regulation of viral genome replication - Inflammatory response - Regulation of cell division - Cell adhesion

death and apoptosis were frequently identified as hits for GO and pathway analysis. Interestingly, at the time of cell harvesting (40hpi) IMR-90 cells infected with the R262/263E virus had led to some cell clearance and cell morphology changes, such as cellular blebbing, that was not present in cells infected with any other HAdV (data not shown). We hypothesized that these phenotypic changes were not due to cytopathic effect (CPE) caused by the virus, which is typically seen as cell detachment, rounding, and swelling, but rather that the cells were undergoing programmed cell death. To investigate the possibility that the R262/263E HAdV causes apoptosis, we looked for DNA fragmentation in infected IMR-90 cells using the TUNEL assay (Figure 4.6). While wildtype HAdV showed no detectable signal, cells infected with the R262/263E viral mutant revealed a positive signal for DNA fragmentation. Taken together, these results revealed that R262/263E does indeed induce apoptosis, verifying some of the trends that we observed *in silico* through pathway analysis (Table 4.1).

4.4 Discussion

The work described herein focuses on an ongoing investigation into the global changes in gene expression induced by a panel of viruses including wildtype HAdV, a Δ E1A virus, and mutants that disrupt the interaction of the C-terminus of E1A with host target proteins. The goal of this analysis is provide insight into how the interaction of E1A with FOXK1, DYRK1A, HAN11, and CtBP deregulate host cell gene expression to support infection and/or influence oncogenic transformation. Based on the extensive mutational analysis described in Chapter 2 of this thesis, we engineered two novel genomic viruses with mutations at the C-terminus of the E1A protein that disrupt the DYRK1A/HAN11 and CtBP interaction, respectively (Figure 4.2), and utilized a previously generated HAdV that fails to interact with the other C-terminal E1A target, FOXK1. RNA from infected growth-arrested IMR-90 cells was subjected to whole transcriptome RNAseq. To date, we have conducted hierarchal gene clustering of all the genes sequenced, explored the differential gene expression profile of cells infected with wildtype HAdV or our panel of HAdV mutants and reported cellular pathways and genes that are affected. Finally, we began preliminary functional experiments to investigate the induction of apoptosis by the R262/263E HAdV mutant, which fails to bind DYRK1A/HAN11.

Figure 4.5 Comparisons of DE genes identified for each C-terminal target of E1A

Venn diagrams summarizing overlaps among differentially expressed genes between dl309 vs. Mock (blue) and dl309 vs. dl312 (green) compared to dl309 vs. dl1132, R262/263E, or Δ PLDLS infected cells (yellow). Genes that were uniquely upregulated (left panel) or downregulated (right panel) for each C-terminal E1A mutant are highlighted by red boxes.

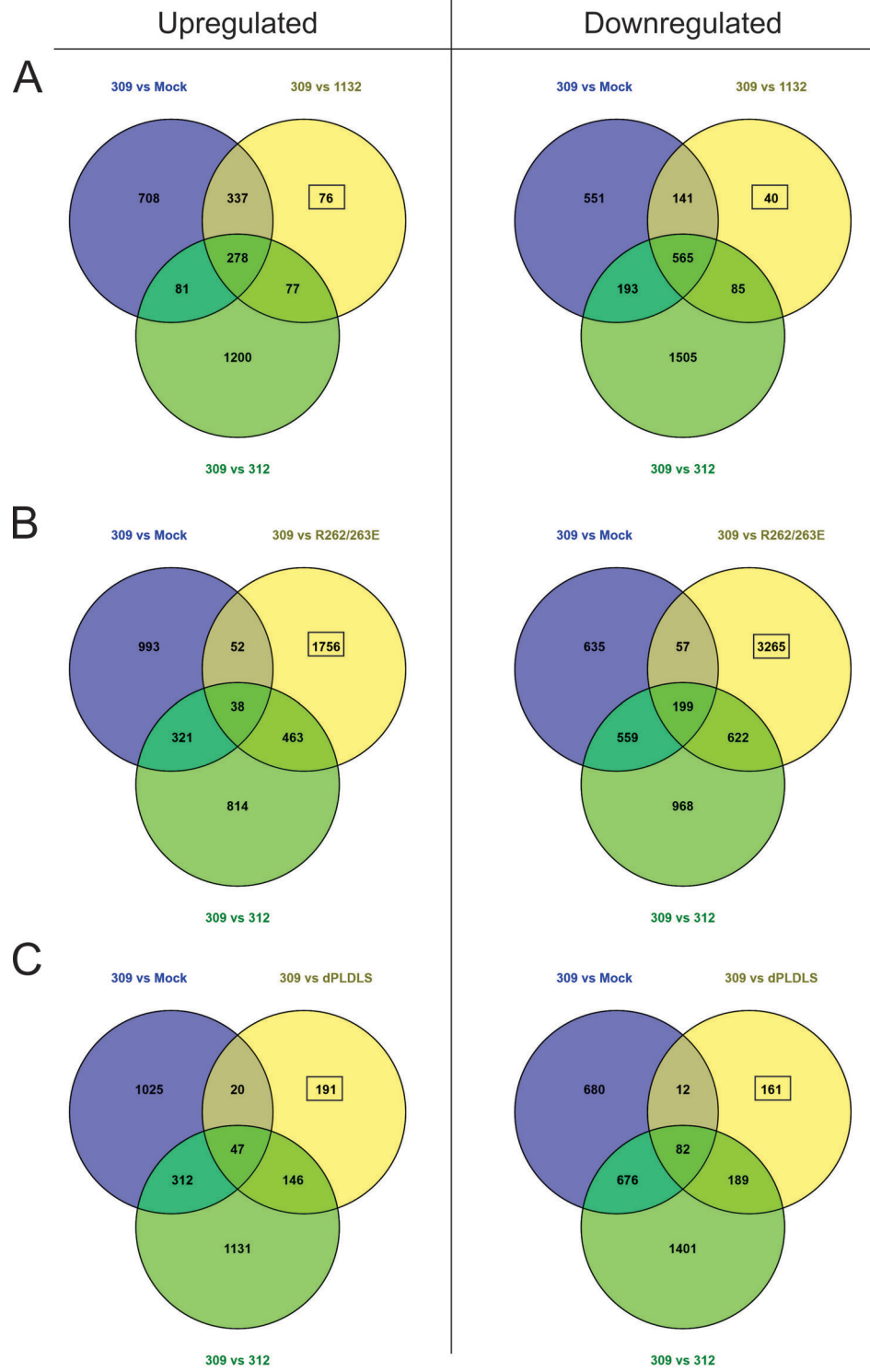

Hierarchical gene clustering and differential expression profiling revealed numerous alterations in gene expression among our panel of HAdVs (Figures 4.3 and 4.4). KEGG pathway and GO enrichment analysis identified both expected and interesting trends (Table 4.1). For example, upregulated pathways and biological functions for dl309 vs Mock- or dl312-infected cells included DNA replication, and cell cycle progression, two processes that are heavily regulated by E1A (Gallimore and Turnell 2001; Berk 2013). Since CtBP typically represses ZEB1 leading to a downregulation of genes such as E-cadherin (Peinado et al. 2007), unsurprisingly, cell adhesion pathways were affected in the Δ PLDLS virus. The most striking trend that we observed was that the R262/263E HAdV mutant induced the most extensive transcriptional changes, with over 6000 genes being differentially expressed when compared to wildtype HAdV. A deficiency in DYRK1A and HAN11 binding during infection appeared to significantly impact pathways in cancer and apoptosis and biological functions such as transcriptional regulation and FoxO signalling.

The DYRKs have been shown to function as survival kinases in a number of cancers (Lee et al. 2000; Deng et al. 2006; Chang et al. 2007; Jin et al. 2007). Mechanistically, DYRK1A acts as a negative regulator of the intrinsic apoptotic pathway by phosphorylating caspase-9, thereby inhibiting its activity (Laguna et al. 2008; Seifert et al. 2008). DYRK1A is also involved in p53-mediated cell survival during DNA damage by phosphorylating a p53 inhibitor, SIRT1 (Guo et al. 2010). Based on these previous studies and the observation that a number of downregulated genes were associated with the regulation of cell death, we investigated the potential that the R262/263E virus induces apoptosis. Indeed, IMR-90 cells infected with R262/263E exhibited morphology changes indicative of apoptosis and were positive for TUNEL stain of DNA breaks (Figure 4.6). Further experiments are necessary to verify these results using additional molecular techniques, such as western blots for caspase cleavage, which is an earlier event in the apoptotic cascade. Furthermore, a small molecule inhibitor called Harmine that is highly specific to DYRK1A is commercially available (Adayev et al. 2011). It is tempting to speculate that cells infected with wildtype HAdV and treated with Harmine would lead to similar transcriptional changes and phenotypic consequences to that of the R262/263E virus. Nonetheless, these preliminary results suggest that the

Figure 4.6 Induction of apoptosis by the R262/263E HAdV mutant

Confocal fluorescence microscopy of infected IMR-90 cells. Cells were fixed 40hpi and DNA breaks were visualized by TUNEL staining (green). Negative control wells received no TUNEL enzyme, while positive control wells were treated with DNase prior to staining. E1A (red) was stained with α E1A antibodies (M58) and AlexaFluor 594 α Mouse probes. Nuclei were stained with DAPI. White bars represent 20 μ m.

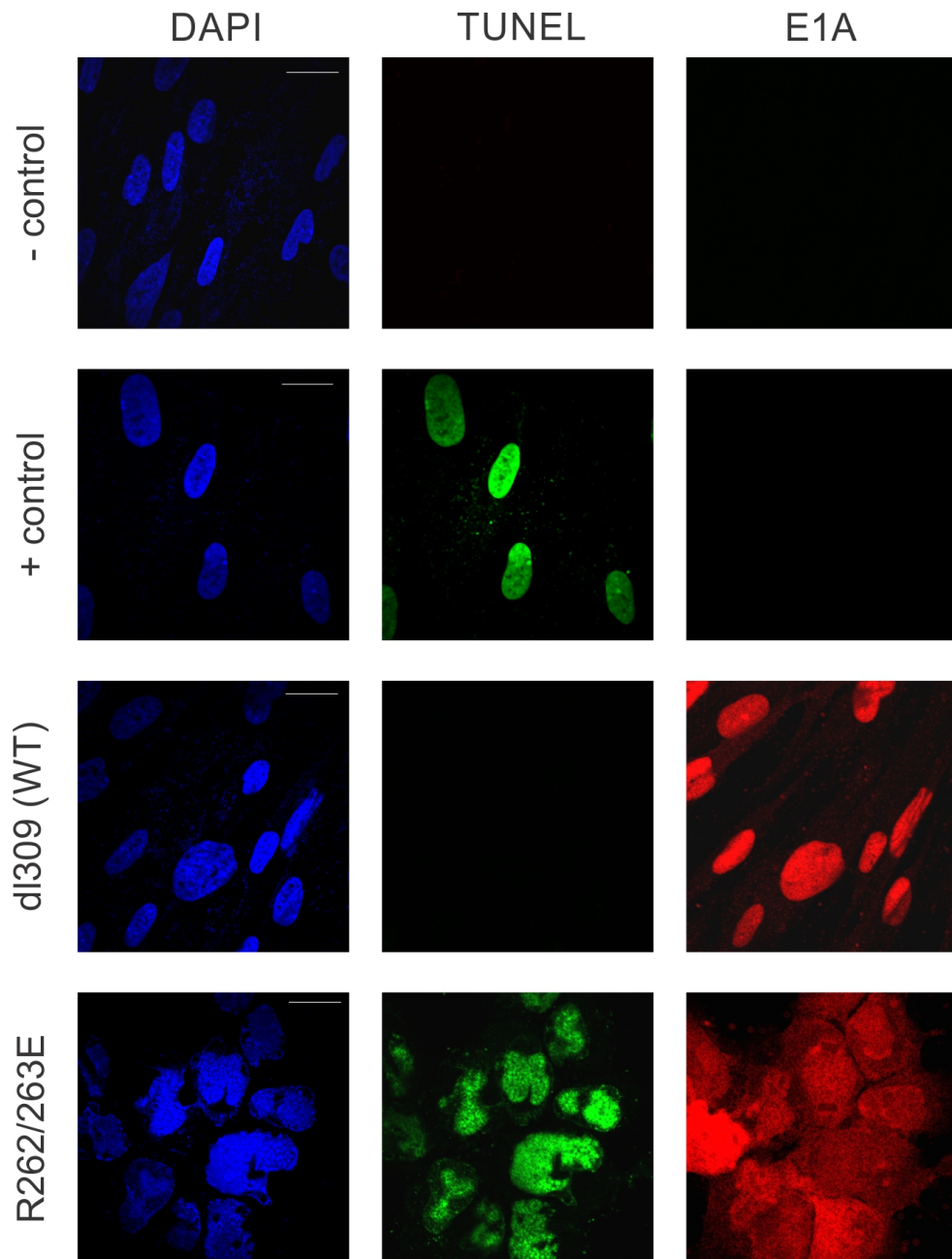

DYRK1A/HAN11 interactions may contribute to E1A-mediated oncogenic transformation by enhancing cell survival.

We have only just begun scratching the surface of the vast amount of data obtained from these RNAseq experiments. A more thorough bioinformatic analysis is necessary to continue mining deeper into the gene alterations caused by the interaction of the C-terminus of E1A with each of these targets. Importantly, due to the interest of time, we did not concentrate on the expression of any specific genes and rather focused our attention on the broad impact of biological pathways and molecular functions. The next logical step in this investigation is to specifically identify known, or potentially novel genes that are regulated by each individual C-terminal target of E1A. Any significant changes in gene expression identified will have to be confirmed and verified using real time PCR in repeat infections. Furthermore, the role of selected candidate genes in E1A-mediated oncogenic transformation could also be assessed by experiments in which each target is knocked down by siRNA.

Another important aspect of this work is to study the changes in viral gene expression caused by these E1A mutants by aligning the RNAseq reads that we obtained to the HAdV genome and conducting a similar expression profile analysis. Differential expression of both early and/or late genes HAdV can provide valuable insight into why E1A targets these cellular proteins and how it benefits the virus. Furthermore, full characterization of the growth kinetics of the novel R262/263E and Δ PLDLS viral mutants and their ability to induce S-phase are also necessary. Overall, next-generation RNAseq has provided us with a wealth of information that we can use as a guide to navigate further investigations into understanding the underlying mechanism as to how the interactions carried out by the C-terminus of E1A affect oncogenic transformation.

4.5 References

- Adayev, T., J. Wegiel and Y. W. Hwang (2011). "Harmine is an ATP-competitive inhibitor for dual-specificity tyrosine phosphorylation-regulated kinase 1A (Dyrk1A)." Arch Biochem Biophys **507**(2): 212-8.
- Ashburner, M., C. A. Ball, J. A. Blake, D. Botstein, H. Butler, J. M. Cherry, A. P. Davis, K. Dolinski, S. S. Dwight, J. T. Eppig, M. A. Harris, D. P. Hill, L. Issel-Tarver, A. Kasarskis, S. Lewis, J. C. Matese, J. E. Richardson, M. Ringwald, G. M. Rubin and G. Sherlock (2000). "Gene ontology: tool for the unification of biology. The Gene Ontology Consortium." Nat Genet **25**(1): 25-9.
- Bayley, S. and J. Mymryk (1994). "Adenovirus e1a proteins and transformation (review)." Int J Oncol **5**(3): 425-44.
- Berk, A. (2013). Adenoviridae. (Philadelphia: Lippincot - Raven), Philadelphia: Wolters Kluwer Health/Lippincott Williams & Wilkins.
- Boyd, J. M., T. Subramanian, U. Schaeper, M. La Regina, S. Bayley and G. Chinnadurai (1993). "A region in the C-terminus of adenovirus 2/5 E1a protein is required for association with a cellular phosphoprotein and important for the negative modulation of T24-ras mediated transformation, tumorigenesis and metastasis." Embo J **12**(2): 469-78.
- Chang, H. S., C. H. Lin, C. H. Yang, M. S. Yen, C. R. Lai, Y. R. Chen, Y. J. Liang and W. C. Yu (2007). "Increased expression of Dyrk1a in HPV16 immortalized keratinocytes enable evasion of apoptosis." Int J Cancer **120**(11): 2377-85.
- Chinnadurai, G. (2009). "The transcriptional corepressor CtBP: a foe of multiple tumor suppressors." Cancer Res **69**(3): 731-4.
- Cohen, M. J., A. F. Yousef, P. Massimi, G. J. Fonseca, B. Todorovic, P. Pelka, A. S. Turnell, L. Banks and J. S. Mymryk (2013). "Dissection of the C-terminal region of E1A redefines the roles of CtBP and other cellular targets in oncogenic transformation." J Virol **87**(18): 10348-55.
- de Hoon, M. J., S. Imoto, J. Nolan and S. Miyano (2004). "Open source clustering software." Bioinformatics **20**(9): 1453-4.
- Deng, X., D. Z. Ewton, S. Li, A. Naqvi, S. E. Mercer, S. Landas and E. Friedman (2006). "The kinase Mirk/Dyrk1B mediates cell survival in pancreatic ductal adenocarcinoma." Cancer Res **66**(8): 4149-58.
- Ferrari, R., D. Gou, G. Jawdekar, S. A. Johnson, M. Nava, T. Su, A. F. Yousef, N. R. Zemke, M. Pellegrini, S. K. Kurdistani and A. J. Berk (2014). "Adenovirus small E1A employs the lysine acetylases p300/CBP and tumor suppressor Rb to repress select host genes and promote productive virus infection." Cell Host Microbe **16**(5): 663-76.

- Flint, J. and T. Shenk (1997). "Viral transactivating proteins." Annu Rev Genet **31**: 177-212.
- Frisch, S. M. and J. S. Mymryk (2002). "Adenovirus-5 E1A: paradox and paradigm." Nat Rev Mol Cell Biol **3**(6): 441-52.
- Gallimore, P. H. and A. S. Turnell (2001). "Adenovirus E1A: remodelling the host cell, a life or death experience." Oncogene **20**(54): 7824-35.
- Granberg, F., C. Svensson, U. Pettersson and H. Zhao (2006). "Adenovirus-induced alterations in host cell gene expression prior to the onset of viral gene expression." Virology **353**(1): 1-5.
- Guo, X., J. G. Williams, T. T. Schug and X. Li (2010). "DYRK1A and DYRK3 promote cell survival through phosphorylation and activation of SIRT1." J Biol Chem **285**(17): 13223-32.
- Heinz, S., C. Benner, N. Spann, E. Bertolino, Y. C. Lin, P. Laslo, J. X. Cheng, C. Murre, H. Singh and C. K. Glass (2010). "Simple combinations of lineage-determining transcription factors prime cis-regulatory elements required for macrophage and B cell identities." Mol Cell **38**(4): 576-89.
- Huang da, W., B. T. Sherman and R. A. Lempicki (2009). "Bioinformatics enrichment tools: paths toward the comprehensive functional analysis of large gene lists." Nucleic Acids Res **37**(1): 1-13.
- Huang da, W., B. T. Sherman and R. A. Lempicki (2009). "Systematic and integrative analysis of large gene lists using DAVID bioinformatics resources." Nat Protoc **4**(1): 44-57.
- Jin, K., S. Park, D. Z. Ewton and E. Friedman (2007). "The survival kinase Mirk/Dyrk1B is a downstream effector of oncogenic K-ras in pancreatic cancer." Cancer Res **67**(15): 7247-55.
- Jones, N. and T. Shenk (1979). "An adenovirus type 5 early gene function regulates expression of other early viral genes." Proc Natl Acad Sci U S A **76**(8): 3665-9.
- Kanehisa, M. and S. Goto (2000). "KEGG: kyoto encyclopedia of genes and genomes." Nucleic Acids Res **28**(1): 27-30.
- Kanehisa, M., S. Goto, S. Kawashima and A. Nakaya (2002). "The KEGG databases at GenomeNet." Nucleic Acids Res **30**(1): 42-6.
- Komorek, J., M. Kuppaswamy, T. Subramanian, S. Vijayalingam, E. Lomonosova, L. J. Zhao, J. S. Mymryk, K. Schmitt and G. Chinnadurai (2010). "Adenovirus type 5 E1A and E6 proteins of low-risk cutaneous beta-human papillomaviruses suppress cell transformation through interaction with FOXK1/K2 transcription factors." J Virol **84**(6): 2719-31.

- Laguna, A., S. Aranda, M. J. Barallobre, R. Barhoum, E. Fernandez, V. Fotaki, J. M. Delabar, S. de la Luna, P. de la Villa and M. L. Arbones (2008). "The protein kinase DYRK1A regulates caspase-9-mediated apoptosis during retina development." Dev Cell **15**(6): 841-53.
- Lee, K., X. Deng and E. Friedman (2000). "Mirk protein kinase is a mitogen-activated protein kinase substrate that mediates survival of colon cancer cells." Cancer Res **60**(13): 3631-7.
- Mymryk, J. S. (1996). "Tumour suppressive properties of the adenovirus 5 E1A oncogene." Oncogene **13**(8): 1581-9.
- Mymryk, J. S. and S. T. Bayley (1993). "Induction of gene expression by exon 2 of the major E1A proteins of adenovirus type 5." J Virol **67**(12): 6922-8.
- Peinado, H., D. Olmeda and A. Cano (2007). "Snail, Zeb and bHLH factors in tumour progression: an alliance against the epithelial phenotype?" Nat Rev Cancer **7**(6): 415-28.
- Pelka, P., J. N. Ablack, G. J. Fonseca, A. F. Yousef and J. S. Mymryk (2008). "Intrinsic structural disorder in adenovirus E1A: a viral molecular hub linking multiple diverse processes." J Virol **82**(15): 7252-63.
- Saldanha, A. J. (2004). "Java Treeview--extensible visualization of microarray data." Bioinformatics **20**(17): 3246-8.
- Seifert, A., L. A. Allan and P. R. Clarke (2008). "DYRK1A phosphorylates caspase 9 at an inhibitory site and is potently inhibited in human cells by harmine." Febs J **275**(24): 6268-80.
- Tollefson, A. E., M. Kuppuswamy, E. V. Shashkova, K. Doronin and W. S. Wold (2007). "Preparation and titration of CsCl-banded adenovirus stocks." Methods Mol Med **130**: 223-35.
- Wang, Z., M. Gerstein and M. Snyder (2009). "RNA-Seq: a revolutionary tool for transcriptomics." Nat Rev Genet **10**(1): 57-63.
- Woods, Y. L., G. Rena, N. Morrice, A. Barthel, W. Becker, S. Guo, T. G. Unterman and P. Cohen (2001). "The kinase DYRK1A phosphorylates the transcription factor FKHR at Ser329 in vitro, a novel in vivo phosphorylation site." Biochem J **355**(Pt 3): 597-607.
- Zhang, Z., M. M. Smith and J. S. Mymryk (2001). "Interaction of the E1A oncoprotein with Yak1p, a novel regulator of yeast pseudohyphal differentiation, and related mammalian kinases." Mol Biol Cell **12**(3): 699-710.

Chapter 5

5 General Discussion and Future Directions

5.1 Thesis Summary

The C-terminus of E1A is considered to be the final frontier of E1A biology, as it is the least studied part of the protein. Although this region is critical for oncogenic transformation of rodent cells by E1A, the underlying mechanisms are still not well understood. Like all other regions of E1A, the model by which the C-terminus of E1A carries out its functions is by interacting with key cellular regulatory proteins and inhibiting or altering their functions. Historically, the only known target of this region of E1A was CtBP and this interaction was implicated in both transformation with E1B and the suppression of transformation with Ras. More recently, newer targets of E1A were discovered to bind to this region, complicating the interpretation of the roles of CtBP (Figure 1.8).

This body of work describes my studies on the C-terminal region of E1A and the cellular proteins that bind to this region: FOXK1/2, DYRK1A/1B, CtBP1/2 and importin- α . Specifically, in Chapter 2 of this thesis, I determined which interactions are conserved amongst different HAdV species (Figure 2.2). I then conducted a mutational analysis of E1A as a means of identifying key residues required for binding to the cellular targets that interact in this region. With these critical reagents in hand, I analyzed each mutant for their ability to localize to the nucleus (Figure 2.5) and affect oncogenic transformation of rodent cells with E1B or Ras (Figure 2.8). In Chapter 3, I carried out another more focused mutational analysis and discovered that E1A requires two clusters of basic residues at its extreme C-terminus for efficient binding to importin- α (Figure 3.2). I further identified and mapped a novel bipartite NLS at the C-terminus of E1A that was necessary and sufficient for full nuclear localization (Figures 3.3 and 3.4). Finally, in Chapter 4, I continued to explore the mechanisms by which FOXK1/2, DYRK1A/B, and CtBP1/2 contribute to E1A-mediated oncogenic transformation. I utilized next-generation RNAseq to investigate the global changes in gene expression between wildtype HAdV

and HAdV mutants unable to interact with each C-terminal target. I conducted a preliminary analysis of this massive dataset using hierarchical gene clustering (Figure 4.3) and differential gene expression comparisons (Figure 4.4), as well as KEGG and GO enrichment analysis (Table 4.1). These results revealed that disruption of the DYRK1A and HAN11 interactions lead to the largest aberration in gene expression and this may contribute to oncogenic transformation in cooperation with E1B by protecting the cell from apoptosis during HAdV infection.

Overall, by conducting a precise and systematic dissection of the C-terminal portion of E1A, I have been able to refine and expand upon previous models, ultimately advancing our current understanding of some of the critical functions carried out by this viral oncoprotein. Furthermore, E1A has once again proven to be an invaluable tool for exploring and elucidating the functions of cellular regulatory proteins and the mechanisms by which they control fundamental cellular processes.

5.2 Redefining the models of E1A-mediated oncogenic transformation by the C-terminus of E1A

Our dissection of the C-terminus of E1A began with identifying which interactions are evolutionarily conserved amongst different HAdV species. We showed that FOXK1 interacted exclusively with HAdV5 E1A, representing members from species C HAdV (Figure 2.2B), thereby confirming that its binding site is mapped to a distinctive region of E1A found only in this species (Avvakumov et al. 2004; Komorek et al. 2010). Conversely, the DYRK1A and HAN11 interaction were found to be highly conserved among all HAdV types tested (Figure 2.2B), suggesting that interaction of E1A with DYRK and HAN11 is highly beneficial to virus infection. Finally, and unexpectedly, the interaction between E1A and CtBP was not as highly conserved amongst different HAdV species, despite the presence of a PLDLS-like motif in each of the E1A proteins (Figure 2.2A). We showed that any deviation from the preferred PLDLS SLIM reduced or abrogated binding to CtBP. Importantly, a seventh HAdV species identified in 2007, which contains one member (HAdV52) (Jones et al. 2007), was not used during our studies. However, the C-terminus and CR4 from HAdV52 shares high sequence

homology to other HAdV types (Figure 3.1) and it would therefore be interesting to investigate these interactions using E1A from this species.

We next conducted transformation assays in BRK cells using a panel of E1A mutants that were specifically deficient for binding to each C-terminal target in isolation (Figure 2.3). These results confirmed that the CtBP-E1A interaction is necessary for oncogenic transformation in cooperation with E1B using the Δ PLDLS mutant (Figure 2.8A). Furthermore, disruption of the DYRK1A and HAN11 interaction caused by specific point mutations were also defective for transformation, indicating that these two interactions may be the missing factors necessary for this phenotypic effect. Unlike cooperation with E1B, the C-terminus of E1A suppresses transformation with Ras, and E1A mutants lacking the C-terminus of E1A induce a hypertransforming phenotype. This phenomenon has previously been linked to the interaction with CtBP via relatively imprecise mutational analysis (Schaeper et al. 1995; Chinnadurai 2004; Komorek et al. 2010). However, the Δ PLDLS mutant used in this study, which disrupts the CtBP interaction without compromising DYRK1A or HAN11 binding, transformed like wildtype E1A (Figure 2.8B). In contrast, some E1A point mutants lacking the ability to bind DYRK1A or HAN11 induced a hypertransforming phenotype, potentially linking these two proteins to the suppression of transformation by E1A with activated Ras. Taken together, our results have allowed us to re-define and expand upon past studies on oncogenic transformation mediated by the C-terminus of E1A.

Recently, we have collaborated with Dr. Walter Becker's laboratory on a study that has shed new light on the DYRK1A-HAN11-E1A interaction. Our work had previously suggested that E1A bound DYRK1A directly and that pulldown of HAN11 was the consequence of an indirect interaction (Cohen et al. 2013). To test this hypothesis, knockdown experiments were conducted to determine the roles of DYRK1A and HAN11 in forming a complex with E1A (Glenewinkel, et al., unpublished). Interestingly, the E1A-HAN11 interaction was not affected by knockdown of endogenous DYRK1A, whereas knockdown of HAN11 completely abolished the binding of E1A to DYRK1A. These novel results indicate that HAN11 is an essential adaptor protein that is necessary

for the association of E1A with DYRK1A, further expanding our understanding of these interactions.

E1A contains a consensus DYRK1A phosphorylation site (RPXSP) containing Serine 219 (Ser219), which is known to be phosphorylated (Tremblay et al. 1988; Himpel et al. 2001). Phosphorylation at Ser219 is a post-translational modification that is critical for the interaction of E1A with FOXK1/2 (Komorek et al. 2010), and this raises the possibility that DYRK1A contributes to FOXK1/2 binding. Interestingly, a peptide mimicking the sequence around Ser219 of E1A was shown to be one of the best in vitro substrates for DYRK1A among over 700 peptides tested (Papadopoulos et al. 2011). Importantly, DYRK1A overexpression in vivo did not affect the levels of E1A phosphorylated at Ser219, but it did increase the level of phosphorylated E1A at other unknown residues in a HAN11-dependent manner (Glenewinkel et al., unpublished). Therefore, E1A appears to be acting as a scaffold, hijacking and redirecting the activity of HAN11 to facilitate its intramolecular phosphorylation by DYRK1A. Taken together, these novel results further refine our model of E1A-mediated oncogenic transformation, and suggest that there is still much more to uncover.

5.3 Altering our understanding of one of the oldest documented NLSs

As mentioned previously, an efficient nuclear localization is known to be required for immortalization by E1A (Douglas and Quinlan 1994; Douglas and Quinlan 1995). Therefore, we conducted immunofluorescence analysis to determine the subcellular localization of the point mutants created in Chapter 2. All point mutants resulted in a diffuse nuclear localization phenotype, with the exception of the R262/263E mutant (Figures 2.5 and 2.6). This point mutant exhibited a nuclear/cytoplasmic phenotype, similar to that of an E1A mutant lacking the previously characterized monopartite NLS at residues 285-289 (Lyons et al. 1987). These results coincided with co-IP experiments in that any of the E1A mutants tested that were deficient for nuclear localization also showed a decreased ability to interact with Qip1, the preferred NLS receptor for E1A (Kohler et al. 2001).

Still, the question remained as to why a point mutant distant from the conserved monopartite NLS of E1A would be deficient for nuclear localization. In Chapter 3 of this thesis, we investigated this paradox and we predicted that E1A may contain a larger bipartite NLS that includes the cluster of basic amino acid residues at the extreme C-terminus described as a monopartite NLS, as well as an upstream cluster of basic residues surrounding the critical R262/263 region. Using Qip1 mutants, we showed that the C-terminus of E1A requires both the major and minor binding groove of Qip1 for efficient binding, which is indicative of a bipartite signal (Figure 3.2). Furthermore, using a panel of E1A truncation mutants, we confirmed that E1A does indeed contain a bipartite NLS from residues 258-289 which is required for binding to Qip1 (Figure 3.3) and is sufficient for nuclear localization (Figure 3.4). The monopartite C-terminal E1A NLS was identified in 1987, and was one of the earliest sequences from any viral or cellular protein that was shown to confer nuclear localization (Lyons et al. 1987). Based on the results described in Chapter 3 of this thesis, we now know that the original E1A NLS was misidentified and is actually a bipartite NLS. The identification of these sequences as a bipartite NLS explains a number of observations in the E1A literature related to subcellular localization and phenotype that have not fit previous models (Douglas and Quinlan 1995; Douglas and Quinlan 1996). My results also raise the possibility that monopartite NLSs from other cellular or viral proteins that may have been mapped using the E1A NLS as an example sequence should be re-evaluated. Furthermore, this demonstrates that a more careful approach to identifying and characterizing novel localization sequences is necessary.

5.4 The potential role of DYRK1A, HAN11, and CtBP in E1A-mediated oncogenic transformation with E1B

The work presented in Chapters 2 and 3 of this thesis sought to systematically reevaluate and further characterize the C-terminal region of E1A. My data, and the conclusions taken from these results, corrected some of the previous literature on this region of E1A. Still, the underlying molecular mechanisms by which the C-terminal targets of E1A aid in its functions remained to be determined. To delve further into the undiscovered country of E1A, we investigated the global changes in gene expression between cells infected

with either wildtype HAdV, or a panel of mutant viruses expressing E1A that fail to interact with FOXX1/2, DYRK1A/B, or CtBP1/2 using next-generation RNAseq. My approach to study alterations in transcription is based on the known roles of FOXX1/2 as sequence specific transcription factors and the known roles of DYRK1A/B and CtBP as transcriptional regulators. One caveat to this approach is that these proteins can work via other mechanisms besides transcriptional regulation. Therefore, the alteration of several pathways and/or biological functions associated with these interactions may not be identified.

Previous studies have shown that deletion of the FOXX1 binding region does not affect immortalization or transformation with E1B (Quinlan and Douglas 1992; Boyd et al. 1993), however our work described in Chapter 2 confirmed that CtBP, DYRK1A and HAN11 are important for this oncogenic effect. Deficiency in CtBP binding lead to over 300 uniquely DE genes compared to wildtype infection. These were clustered into pathways involved in transcriptional regulation of cancer, cell adhesion, and the inflammatory response. Importantly, deficiency in DYRK1A and HAN11 binding during infection resulted in over 5000 DE genes from pathways involving transcriptional regulation of cancer, viral transcription, and the regulation of cell death.

Due to a lack of time, we focused our attention towards DYRK1A and HAN11, which appears to control the most drastic changes in gene expression during infection. We chose to follow the trend observed in cells infected with the R262/263E HAdV mutant, in which the regulation of cell death and apoptosis was highly affected. Interestingly, we verified that this viral mutant does indeed lead to cell morphology changes and double-stranded DNA-breaks associated with apoptosis using the TUNEL assay. A more precise time course of infection may be necessary to pinpoint the induction of apoptosis in cells infected with an HAdV mutant deficient in DYRK1A and HAN11 binding. Furthermore, it will be important to determine the expression levels of HAdV E1B and other viral genes in this context. As mentioned previously, E1B codes for two proteins (E1B-55K and E1B-19K) that functions during infection to inhibit p53 and block apoptosis (Rao et al. 1992; Yew and Berk 1992; Berk 2013). Therefore, the functions carried out by the E1B proteins may also be affected when the E1A-DYRK1A/HAN11 interaction is

abrogated. Alignment of the RNAseq reads to the HAdV genome will play an important role in answering these questions. Overall, this preliminary analysis has uncovered both expected and novel changes in gene expression controlled by the C-terminal targets of E1A and suggests that the DYRK1A/HAN11 interaction may contribute to oncogenic transformation by enhancing cell survival.

5.5 The potential role of DYRK1A, HAN11, and FOXK1 in E1A-mediated suppression of transformation with Ras

The results described in Chapter 4 shed some light on pathways that are modulated by the C-terminal targets of E1A during infection. We predict that similar molecular pathways may play a role in oncogenic transformation of rodent cells in cooperation with E1B. Still, many questions remain as to how E1A suppresses transformation with activated Ras. The Ras signalling pathway can lead to a variety of cellular responses depending on the duration and localization of extracellular signal-related kinase (ERK) activation, including proliferation, migration, senescence, and even cell death (Murphy and Blenis 2006). Ectopic expression of oncogenic Ras can cause hyper-activation of p53 and p16INK4a and ultimately lead to irreversible growth arrest. This phenomenon has been termed oncogene-induced senescence (OIS) and is very well documented (Serrano et al. 1997; Collado and Serrano 2006; Gorgoulis and Halazonetis 2010). As mentioned previously, DYRK1A has recently been shown to phosphorylate LIN52, a member of the MUVB core complex. This activity triggers assembly of the DREAM complex, which promotes entry into quiescence, growth suppression and senescence (Pilkinton et al. 2007; Litovchick et al. 2011). Phosphorylation of LIN52 was shown to be essential for DREAM assembly and importantly, the interaction between DYRK1A and LIN52 appears to be required for both growth arrest and oncogenic Ras-induced senescence (Litovchick et al. 2011). It is possible that E1A enhances the ability of DYRK1A to induce the formation of the DREAM complex, as this depends directly on the kinase activity of DYRK1A. While this may seem contradictory, since the first exon of E1A sequesters pRb and family members, existing literature suggests that E1A does not quantitatively bind all pRb family proteins in the infected cell (Felsani et al. 2006).

Specifically, the presence of E1A could lead to a hyper-phosphorylation of LIN52 by DYRK1A. This would result in an enhancement of its capacity to bind to DREAM complex members such as p130, ultimately leading to increased levels of growth arrest and Ras-induced senescence as previously documented (Litovchick et al. 2011). This may explain how this region of E1A suppresses Ras induced transformation.

Small GTPase proteins of the RHO family also affect Ras-induced transformation (Van Aelst and D'Souza-Schorey 1997; Nimnual et al. 1998). Previous studies have shown that E1A has a suppressive effect on RAC1 activation by Ras (Fischer and Quinlan 2000), however the mechanism remains unknown. Hypertransformation by C-terminal mutants of E1A is reduced by dominant negative mutants of RAC1, while expression of constitutively active RAC1 rescues the hypertransformation phenotype (Fischer and Quinlan 2000). Interestingly, the *C. elegans* orthologue of HAN11 negatively regulates the GTPase activity of both human and *C. elegans* orthologues of RAC1 (Yang et al. 2006). Therefore, the interaction of E1A with HAN11 may play a role in E1A-mediated downregulation of RAC signaling, causing a suppression of Ras-induced transformation.

The FO XK1-E1A interaction has recently been linked to the suppression of Ras-cooperative transformation, as BRK cells expressing E1A mutants unable to bind to FO XK1 produced an increased number of transformed colonies compared to wildtype E1A. Furthermore, these transformed cells exhibited increased tumourigenicity in athymic mice (Komorek et al. 2010). It is important to note, as mentioned above, that this interaction with HAdV-5 E1A is not a universal phenomenon shared by all E1A proteins, as it binds to a region of E1A that is exclusively found in Species C HAdVs. It is possible that these HAdVs have evolved to take advantage of the more highly conserved DYRK1A interaction, which can phosphorylate E1A on Ser219 and mediate FO XK1 binding. The overall expression levels and kinase activity of DYRK1A may therefore mediate the suppressive effect that FO XK1 has on E1A. This may explain the rather contradictory results of earlier studies showing that tumourigenesis was not enhanced by deletion of the FO XK1 binding region (Boyd et al. 1993). Interestingly, the E6 oncoproteins from low-risk cutaneous human papillomaviruses (HPV) were also shown to interact with FO XK1/K2 through the same motif found in E1A, which may suggest

that this interaction is important for a specific environmental niche or cell population infected by these epithelial tropic viruses.

5.6 Concluding Remarks

E1A has historically been an excellent biochemical tool to study transcriptional activation and oncogenic transformation of cells. Since the initial discovery 30 years ago that E1A interacted with cellular proteins (Yee and Branton 1985; Harlow et al. 1986) investigation of these interactions have contributed enormously to our understanding of the basic principles of normal and malignant cell growth. My work described herein continues this research by providing some much needed insight into the processes carried out by the C-terminus of E1A and the functions of the cellular proteins that bind to this region. Within less than 100 amino acids, the C-terminus of E1A interacts with FOXK1/2, DYRK1A/1B, HAN11, CtBP1/2, importin- α 3, and potentially other undiscovered proteins. Thus, this region of E1A appears to assemble an elegant molecular complex of regulatory proteins in order to hijack their biological activities to benefit the virus. The consequences of these interactions lead to an alteration of important cellular processes, including cell-cycle progression, cell survival, and tumour development. My studies on the C-terminus of E1A have provided the paths for future scientific investigation that could lead to further discovery and understanding on these subjects. Large scale analysis of the oncoproteins of multiple DNA tumor viruses have confirmed the value of using these viral products as molecular tools to identify and study key cancer related targets and pathways (Rozenblatt-Rosen et al. 2012). Hence, viral oncoproteins, such as HAdV E1A, will continue to be of immense value for advancing our knowledge of the function of the cellular regulatory proteins they target and solving unanswered questions in molecular biology.

5.7 References

- Avvakumov, N., A. E. Kajan, R. C. Hoeben and J. S. Mymryk (2004). "Comprehensive sequence analysis of the E1A proteins of human and simian adenoviruses." Virology 329(2): 477-92.
- Berk, A. (2013). Adenoviridae. (Philadelphia: Lippincot - Raven), Philadelphia: Wolters Kluwer Health/Lippincott Williams & Wilkins.
- Boyd, J. M., T. Subramanian, U. Schaeper, M. La Regina, S. Bayley and G. Chinnadurai (1993). "A region in the C-terminus of adenovirus 2/5 E1a protein is required for association with a cellular phosphoprotein and important for the negative modulation of T24-ras mediated transformation, tumorigenesis and metastasis." Embo J 12(2): 469-78.
- Chinnadurai, G. (2004). "Modulation of oncogenic transformation by the human adenovirus E1A C-terminal region." Curr Top Microbiol Immunol 273: 139-61.
- Cohen, M. J., A. F. Yousef, P. Massimi, G. J. Fonseca, B. Todorovic, P. Pelka, A. S. Turnell, L. Banks and J. S. Mymryk (2013). "Dissection of the C-terminal region of E1A redefines the roles of CtBP and other cellular targets in oncogenic transformation." J Virol 87(18): 10348-55.
- Collado, M. and M. Serrano (2006). "The power and the promise of oncogene-induced senescence markers." Nat Rev Cancer 6(6): 472-6.
- Douglas, J. L. and M. P. Quinlan (1994). "Efficient nuclear localization of the Ad5 E1A 12S protein is necessary for immortalization but not cotransformation of primary epithelial cells." Cell Growth Differ 5(5): 475-83.
- Douglas, J. L. and M. P. Quinlan (1995). "Efficient nuclear localization and immortalizing ability, two functions dependent on the adenovirus type 5 (Ad5) E1A second exon, are necessary for cotransformation with Ad5 E1B but not with T24ras." J Virol 69(12): 8061-5.
- Douglas, J. L. and M. P. Quinlan (1996). "Structural limitations of the Ad5 E1A 12S nuclear localization signal." Virology 220(2): 339-49.
- Felsani, A., A. M. Mileo and M. G. Paggi (2006). "Retinoblastoma family proteins as key targets of the small DNA virus oncoproteins." Oncogene 25(38): 5277-85.
- Fischer, R. S. and M. P. Quinlan (2000). "While E1A can facilitate epithelial cell transformation by several dominant oncogenes, the C-terminus seems only to regulate rac and cdc42 function, but in both epithelial and fibroblastic cells." Virology 269(2): 404-19.
- Gorgoulis, V. G. and T. D. Halazonetis (2010). "Oncogene-induced senescence: the bright and dark side of the response." Curr Opin Cell Biol 22(6): 816-27.

- Harlow, E., P. Whyte, B. R. Franza, Jr. and C. Schley (1986). "Association of adenovirus early-region 1A proteins with cellular polypeptides." Mol Cell Biol 6(5): 1579-89.
- Himpel, S., P. Panzer, K. Eirnbter, H. Czajkowska, M. Sayed, L. C. Packman, T. Blundell, H. Kentrup, J. Grotzinger, H. G. Joost and W. Becker (2001). "Identification of the autophosphorylation sites and characterization of their effects in the protein kinase DYRK1A." Biochem J 359(Pt 3): 497-505.
- Jones, M. S., 2nd, B. Harrach, R. D. Ganac, M. M. Gozum, W. P. Dela Cruz, B. Riedel, C. Pan, E. L. Delwart and D. P. Schnurr (2007). "New adenovirus species found in a patient presenting with gastroenteritis." J Virol 81(11): 5978-84.
- Kohler, M., D. Gorlich, E. Hartmann and J. Franke (2001). "Adenoviral E1A protein nuclear import is preferentially mediated by importin alpha3 in vitro." Virology 289(2): 186-91.
- Komorek, J., M. Kuppuswamy, T. Subramanian, S. Vijayalingam, E. Lomonosova, L. J. Zhao, J. S. Mymryk, K. Schmitt and G. Chinnadurai (2010). "Adenovirus type 5 E1A and E6 proteins of low-risk cutaneous beta-human papillomaviruses suppress cell transformation through interaction with FOXK1/K2 transcription factors." J Virol 84(6): 2719-31.
- Litovchick, L., L. A. Florens, S. K. Swanson, M. P. Washburn and J. A. Decaprio (2011). "DYRK1A protein kinase promotes quiescence and senescence through DREAM complex assembly." Genes Dev 25(8): 801-13.
- Lyons, R. H., B. Q. Ferguson and M. Rosenberg (1987). "Pentapeptide nuclear localization signal in adenovirus E1a." Mol Cell Biol 7(7): 2451-6.
- Murphy, L. O. and J. Blenis (2006). "MAPK signal specificity: the right place at the right time." Trends Biochem Sci 31(5): 268-75.
- Nimmual, A. S., B. A. Yatsula and D. Bar-Sagi (1998). "Coupling of Ras and Rac guanosine triphosphatases through the Ras exchanger Sos." Science 279(5350): 560-3.
- Papadopoulos, C., K. Arato, E. Lilienthal, J. Zerweck, M. Schutkowski, N. Chatain, G. Muller-Newen, W. Becker and S. de la Luna (2011). "Splice variants of the dual specificity tyrosine phosphorylation-regulated kinase 4 (DYRK4) differ in their subcellular localization and catalytic activity." J Biol Chem 286(7): 5494-505.
- Pilkinton, M., R. Sandoval and O. R. Colamonici (2007). "Mammalian Mip/LIN-9 interacts with either the p107, p130/E2F4 repressor complex or B-Myb in a cell cycle-phase-dependent context distinct from the Drosophila dREAM complex." Oncogene 26(54): 7535-43.

- Quinlan, M. P. and J. L. Douglas (1992). "Immortalization of primary epithelial cells requires first- and second-exon functions of adenovirus type 5 12S." J Virol 66(4): 2020-30.
- Rao, L., M. Debbas, P. Sabbatini, D. Hockenbery, S. Korsmeyer and E. White (1992). "The adenovirus E1A proteins induce apoptosis, which is inhibited by the E1B 19-kDa and Bcl-2 proteins." Proc Natl Acad Sci U S A 89(16): 7742-6.
- Rozenblatt-Rosen, O., R. C. Deo, M. Padi, G. Adelmant, M. A. Calderwood, T. Rolland, M. Grace, A. Dricot, M. Askenazi, M. Tavares, S. J. Pevzner, F. Abderazzaq, D. Byrdsong, A. R. Carvunis, A. A. Chen, J. Cheng, M. Correll, M. Duarte, C. Fan, M. C. Feltkamp, S. B. Ficarro, R. Franchi, B. K. Garg, N. Gulbahce, T. Hao, A. M. Holthaus, R. James, A. Korkhin, L. Litovchick, J. C. Mar, T. R. Pak, S. Rabello, R. Rubio, Y. Shen, S. Singh, J. M. Spangle, M. Tasan, S. Wanamaker, J. T. Webber, J. Roecklein-Canfield, E. Johannsen, A. L. Barabasi, R. Beroukhim, E. Kieff, M. E. Cusick, D. E. Hill, K. Munger, J. A. Marto, J. Quackenbush, F. P. Roth, J. A. DeCaprio and M. Vidal (2012). "Interpreting cancer genomes using systematic host network perturbations by tumour virus proteins." Nature 487(7408): 491-5.
- Schaeper, U., J. M. Boyd, S. Verma, E. Uhlmann, T. Subramanian and G. Chinnadurai (1995). "Molecular cloning and characterization of a cellular phosphoprotein that interacts with a conserved C-terminal domain of adenovirus E1A involved in negative modulation of oncogenic transformation." Proc Natl Acad Sci U S A 92(23): 10467-71.
- Serrano, M., A. W. Lin, M. E. McCurrach, D. Beach and S. W. Lowe (1997). "Oncogenic ras provokes premature cell senescence associated with accumulation of p53 and p16INK4a." Cell 88(5): 593-602.
- Tremblay, M. L., C. J. McGlade, G. E. Gerber and P. E. Branton (1988). "Identification of the phosphorylation sites in early region 1A proteins of adenovirus type 5 by amino acid sequencing of peptide fragments." J Biol Chem 263(13): 6375-83.
- Van Aelst, L. and C. D'Souza-Schorey (1997). "Rho GTPases and signaling networks." Genes Dev 11(18): 2295-322.
- Yang, Y., J. Lu, J. Rovnak, S. L. Quackenbush and E. A. Lundquist (2006). "SWAN-1, a *Caenorhabditis elegans* WD repeat protein of the AN11 family, is a negative regulator of Rac GTPase function." Genetics 174(4): 1917-32.
- Yee, S. P. and P. E. Branton (1985). "Detection of cellular proteins associated with human adenovirus type 5 early region 1A polypeptides." Virology 147(1): 142-53.
- Yew, P. R. and A. J. Berk (1992). "Inhibition of p53 transactivation required for transformation by adenovirus early 1B protein." Nature 357(6373): 82-5.

Curriculum Vitae

Michael Jason Cohen, M.Sc.
 Department of Microbiology and Immunology
 Schulich School of Medicine and Dentistry
 The University of Western Ontario

Education

The University of Western Ontario

PhD Candidate in Microbiology and Immunology **2010-Present**
 Supervisor: Dr. Joe Mymryk

The University of Western Ontario

MSc in Microbiology and Immunology **2008-2010**
 Supervisors: Dr. Joe Mymryk and Dr. Laura Hertel

The University of Western Ontario

HBSc in Biology **2003-2008**
 Honors Specialization in Biology

Awards and Distinctions

Nellie Farthing Fellowship in Medical Sciences **June 2014**
 \$3000 award for excellence in research as a PhD
 Candidate in the Schulich School of Medicine and Dentistry

John A. Thomas Award **April 2014**
 \$1000 award for recognition as top senior
 PhD Candidate in Microbiology and Immunology

Ontario Graduate Scholarship (OGS) **September 2014**
 \$15,000 scholarship through the Government of Ontario
 (note: award declined due to administrative restrictions)

Ontario Graduate Scholarship (OGS) **September 2012-August 2014**
 \$15,000 scholarship through the Government of Ontario

UWO Oncology Research and Education Day Poster award **June 2012**
 \$100 Award for top 5 judged poster

CIHR Strategic Training Program (CaRTT) **September 2011-August 2013**
 \$26,500 scholarship per year for two years.

Peer Reviewed Publications

- 1) Glenewinkel F, **Cohen MJ**, Kaspar S, Mymryk JS, Becker W
The adaptor protein DCAF7 mediates the interaction of the adenovirus E1A oncoprotein with the protein kinases DYRK1A and HIPK2
Scientific Reports 2015 – Under Revision (submission #: SREP-15-20180)
Impact Factor: 5.58
- 2) **Cohen MJ**, King CR, Dikeakos JD, Mymryk JS
Functional analysis of the C-terminal region of human adenovirus E1A reveals a misidentified nuclear localization signal
Virology 2014 Nov;468-470:238-43
Impact Factor: 3.376
- 3) Fonseca GJ, **Cohen MJ**, Mymryk JS
Adenovirus E1A recruits the hPaf1 complex to enhance transcriptional elongation
J Virol. 2014 May;88(10): 5630-7
Impact Factor: 5.076
- 4) Marshall KS, **Cohen MJ**, Fonseca GJ, King CR, Yousef AY, Zhang Z, Mymryk JS
Identification and characterization of multiple conserved nuclear localization signals within adenovirus E1A
Virology 2014 Apr;454-455:206-14
Impact Factor: 3.376
- 5) **Cohen MJ**, Yousef AF, Massimi P, Fonseca GJ, Todorovic B, Pelka P, Turnell AS, Banks L, Mymryk JS
Dissection of the C-terminal region of E1A re-defines the roles of CtBP and other cellular targets in oncogenic transformation.
J Virol. 2013 Sep;87(18):10348-55
Impact Factor: 5.076 *Note: Article selected for "Spotlight" of the issue
- 6) Fonseca GJ, **Cohen MJ**, Nichols AC, Barrett JW, Mymryk JS
Viral retasking of hBre1 to recruit hPaf1 for transcriptional activation
PLoS Pathogens 2013;9(6):e1003411
Impact Factor: 8.14
- 7) Ablack JNG, **Cohen MJ**, Fonseca GJ, Thillainadesa G, Pelka P, Torchia J, Mymryk JS
Cellular GCN5 is a novel regulator of human adenovirus E1A-Conserved Region 3 transactivation
J Virol. 2012 Aug;86(15):8198-209
Impact Factor: 5.076

- 8) Yousef AF*, Fonseca GJ*, **Cohen MJ***, Mymryk JS
 (*Note: Authors contributed equally)
 The C-terminal region of E1A: A molecular tool for cellular cartography
 Biochem Cell Biol. 2012 Apr;9(20):153-63
 Impact Factor: 2.915
- 9) Miller MS, Pelka P, Foneca GJ, **Cohen MJ**, Kelly JN, Barr SD, Grand RG, Turnell AS, Whyte P, Mymryk JS
 Characterization of the 55-Residue protein encoded by the 9S E1A mRNA of Species C Adenovirus
 J Virol. 2012 Apr;86(8): 4222-33
 Impact Factor: 5.076
- 10) Vali B, Tohn R, **Cohen MJ**, Sakhdari A, Sheth PM, Yue FY, Wong D, Kovacs C, Kaul R, Ostrowski MA
 Characterization of cross-reactive CD8+ T-cell recognition of HLA-A2-restricted HIV-Gag (SLYNTVATL) and HCV-NS5b (ALYDVVSKL) epitopes in individuals infected with human immunodeficiency and hepatitis C viruses
 J Virol. 2011 Jan;85(1):254-63
 Impact Factor: 5.076

Select Presentations

Cohen MJ, Mymryk JS

Functional analysis of the C-terminal region of human adenovirus E1A reveals a misidentified nuclear localization signal

2014 DNA tumor Virus Meeting, Madison, Wisconsin, *Oral Presentation*

2014 London Health Research Day, London Ontario, *Poster Presentation*

Cohen MJ, Yousef AF, Massimi P, Turnell AS, Banks L, Mymryk JS

Dissection of the C-terminal region of E1A re-defines the roles of CtBP and other cellular targets in oncogenic transformation.

2013 DNA Tumor Virus Meeting, Birmingham UK, *Oral Presentation*

2013 London Health Research Day, London Ontario, *Oral Presentation*

Cohen MJ, Yousef AF, Massimi P, Turnell AS, Banks L, Mymryk JS

Mapping the undiscovered country of the human adenovirus E1A oncoprotein: The C-terminal region and its function

2012 DNA Tumor Virus Meeting, Montreal Quebec, *Oral Presentation*

2012 Oncology Research and Education Day, London Ontario, *Poster Presentation*

2012 London Health Research Day, London Ontario, *Poster Presentation*

Cohen MJ, Yousef AF, Becker W, Mymryk JS

Sifting through the "dyrt" reveals yet another kinase story: Characterizing the interaction between E1A and DYRK1A

2011 DNA Tumor Virus Meeting, Trieste Italy, *Oral Presentation*