

1986

Control Of Movement Initiation In Humans

Susan Holly Brown

Follow this and additional works at: <https://ir.lib.uwo.ca/digitizedtheses>

Recommended Citation

Brown, Susan Holly, "Control Of Movement Initiation In Humans" (1986). *Digitized Theses*. 1525.
<https://ir.lib.uwo.ca/digitizedtheses/1525>

This Dissertation is brought to you for free and open access by the Digitized Special Collections at Scholarship@Western. It has been accepted for inclusion in Digitized Theses by an authorized administrator of Scholarship@Western. For more information, please contact tadam@uwo.ca, wlsadmin@uwo.ca.

The author of this thesis has granted The University of Western Ontario a non-exclusive license to reproduce and distribute copies of this thesis to users of Western Libraries. Copyright remains with the author.

Electronic theses and dissertations available in The University of Western Ontario's institutional repository (Scholarship@Western) are solely for the purpose of private study and research. They may not be copied or reproduced, except as permitted by copyright laws, without written authority of the copyright owner. Any commercial use or publication is strictly prohibited.

The original copyright license attesting to these terms and signed by the author of this thesis may be found in the original print version of the thesis, held by Western Libraries.

The thesis approval page signed by the examining committee may also be found in the original print version of the thesis held in Western Libraries.

Please contact Western Libraries for further information:

E-mail: libadmin@uwo.ca

Telephone: (519) 661-2111 Ext. 84796

Web site: <http://www.lib.uwo.ca/>



National Library
of Canada

Bibliothèque nationale
du Canada

Canadian Theses Service

Services des thèses canadiennes

Ottawa, Canada
K1A 0N4

CANADIAN THESES

THÈSES CANADIENNES

NOTICE

The quality of this microfiche is heavily dependent upon the quality of the original thesis submitted for microfilming. Every effort has been made to ensure the highest quality of reproduction possible.

If pages are missing, contact the university which granted the degree.

Some pages may have indistinct print especially if the original pages were typed with a poor typewriter ribbon or if the university sent us an inferior photocopy.

Previously copyrighted materials (journal articles, published tests, etc.) are not filmed.

Reproduction in full or in part of this film is governed by the Canadian Copyright Act, R.S.C. 1970, c. C-30.

**THIS DISSERTATION
HAS BEEN MICROFILMED
EXACTLY AS RECEIVED.**

AVIS

La qualité de cette microfiche dépend grandement de la qualité de la thèse soumise au microfilmage. Nous avons tout fait pour assurer une qualité supérieure de reproduction.

S'il manque des pages, veuillez communiquer avec l'université qui a conféré le grade.

La qualité d'impression de certaines pages peut laisser à désirer, surtout si les pages originales ont été dactylographées à l'aide d'un ruban usé ou si l'université nous a fait parvenir une photocopie de qualité inférieure.

Les documents qui font déjà l'objet d'un droit d'auteur (articles de revue, examens publiés, etc.) ne sont pas microfilmés.

La reproduction, même partielle, de ce microfilm est soumise à la Loi canadienne sur le droit d'auteur, SRC 1970, c. C-30.

**LA THÈSE A ÉTÉ
MICROFILMÉE TELLE QUE
NOUS L'AVONS REÇUE**

CONTROL OF MOVEMENT INITIATION IN HUMANS

by

Susan H.C. Brown

Department of Physiology

Submitted in partial fulfillment
of the requirements for the degree of
Doctor of Philosophy

Faculty of Graduate Studies,
The University of Western Ontario
London, Ontario
April, 1986

© Susan H.C. Brown 1986

ACKNOWLEDGEMENTS

The completion of this thesis would not have been possible without the help of the following individuals. I wish to thank:

My supervisor, Dr. David Cooke, for his constant encouragement, guidance and friendship. His scientific judgement and curiosity during the course of this study were invaluable. I apologize for the added grey hairs.

Dr. David Ostry, McGill University, whose boundless enthusiasm and support of the work were most encouraging.

Dr. J.J. Seguin, whose daily efforts to dissipate "the little black cloud" were greatly appreciated.

Dr. D. Al-Senawi and W. Darling for making the "Cooke lab" a truly interesting experience.

Finally, I would like to thank those individuals, who willingly or otherwise, agreed to participate in experiments. A special thank you is extended to G.L. whose courage and patience were deeply appreciated. I also thank the technical and secretarial staff for providing services on short notice.

ABSTRACT

Movements about a joint are often initiated by a brief burst of activity in the contracting (agonist) muscle. The initial agonist burst (Agl) is followed sequentially by phasic activation of the antagonist muscle and a second burst of agonist activity. For the past several years, Agl has been considered to represent a preprogrammed component of the descending motor command, the magnitude but not the duration of which could be modulated in order to produce movements of different speeds and/or amplitudes. Two brief reports, however, suggested that Agl duration may vary with both movement amplitude and inertial loading. The purpose of this study was three-fold: one, to determine if Agl duration remained constant over a wide range of movement amplitudes, two, to determine the sensitivity of both Agl magnitude and duration to peripheral feedback, and three, to determine the precise relationship between Agl and the acceleratory phase of the movement.

In the first set of experiments, eight normal human subjects performed a series of step-tracking movements about the elbow. Movement amplitude ranged from 5 to 50 deg. In all subjects both magnitude and duration of Agl increased with movement amplitude. The change in burst duration was not graded but occurred in a step-like manner. Small

movements (5-20 deg) were initiated by short duration bursts (70-80 ms) while large movements (40-50 deg) were initiated by long duration bursts (140-150 ms). Intermediate movement amplitudes were associated with either short or long duration bursts. The step-like change in Agl duration resulted from a second burst or component of agonist activity, the duration of which was approximately equal to that of short duration bursts (70-80 ms). Doubling of Agl duration also occurred in movements made by a deafferented patient, suggesting that afferent feedback was not necessary in order to modulate Agl duration.

In a second set of experiments on five subjects, brief perturbations were randomly applied prior to the onset of either fast or slow flexion movements about the elbow. In 30 deg movements, perturbations which opposed the movement (load) increased the magnitude of both components of Agl while perturbations which assisted the movement (unload) increased the magnitude of the first component but decreased the magnitude of the second. Changes in component magnitude were graded with the size of the perturbation, large perturbations causing a greater change in component magnitude than small perturbations.

In a third set of experiments, the effects of changes in initial elbow joint angle on movement-related electromyographic (EMG) activity were examined. Five subjects performed step-tracking movements about the elbow from

starting joint angles ranging from 65 to 125 deg. In general, the magnitude of Agl associated with flexion movements increased as starting position became more extended. In one subject, little change in Agl magnitude was observed across different starting positions. Movements made by this subject were accompanied by a period of antagonist inhibition prior to movement onset. Movement (phase-plane) trajectories associated with different starting positions were not altered despite large differences in Agl magnitude. It was hypothesized that the changes in EMG activity associated with movement initiation compensate for angle-dependent changes in limb mechanical properties so as to maintain a prelearned movement trajectory.

Finally, experiments were conducted to examine the relationship between phasic EMG activity and movement trajectory. In these experiments, movement amplitude, peak velocity and movement duration were kept constant while altering the ratio of acceleration duration to deceleration duration. As the movement profile shifted from short acceleration to long acceleration movements, both the duration of Agl and time of onset of phasic antagonist activity (relative to movement onset) increased. Large increases in the magnitude of the second agonist burst were associated with long acceleration, short deceleration movements. These findings suggest that the timing and magnitude of movement-related EMG activity are not related

to a single movement parameter such as amplitude or speed
but rather to the profile of the intended movement.

ACKNOWLEDGEMENTS

The completion of this thesis would not have been possible without the help of the following individuals. I wish to thank:

My supervisor, Dr. David Cooke, for his constant encouragement, guidance and friendship. His scientific judgement and curiosity during the course of this study were invaluable. I apologize for the added grey hairs.

Dr. David Ostry, McGill University, whose boundless enthusiasm and support of the work were most encouraging.

Dr. J.J. Seguin, whose daily efforts to dissipate "the little black cloud" were greatly appreciated.

Dr. D. Al-Senawi and W. Darling for making the "Cooke lab" a truly interesting experience.

Finally, I would like to thank those individuals, who willingly or otherwise, agreed to participate in experiments. A special thank you is extended to G.L. whose courage and patience were deeply appreciated. I also thank the technical and secretarial staff for providing services on short notice.

TABLE OF CONTENTS

	Page
CERTIFICATE OF EXAMINATION.....	ii
ABSTRACT.....	iii
ACKNOWLEDGEMENTS.....	vii
TABLE OF CONTENTS.....	viii
LIST OF TABLES.....	xi
LIST OF FIGURES.....	xii
INTRODUCTION.....	1
HISTORICAL REVIEW.....	4
I. Movement Classification.....	4
A. "Fast" versus "slow" movements.....	4
B. EMG activity associated with fast and slow movements.....	6
C. Control mechanisms underlying fast and slow movements.....	7
II. Triphasic EMG Pattern.....	11
A. Function of phasic muscle activity.....	12
B. Generation of the triphasic pattern.....	14
III. Control of Movement Trajectory.....	16
IV. Control of Final End Position.....	19
V. Initial Agonist Burst and Movement Initiation.....	23
A. Evidence for central programming.....	23
B. Movement control theories.....	26
METHODS.....	29
I. General.....	29
A. Normal subjects.....	29
B. Deafferented patient.....	30
II. Experimental Paradigms.....	31
A. Effects of movement amplitude on initial agonist burst duration.....	31
B. Role of peripheral feedback on the initial agonist burst.....	32

1. Effects of perturbations preceding movement on the initial agonist burst.....	32
2. Effects of initial starting position on the initial agonist burst.....	36
C. EMG activity associated with asymmetric movement profiles.....	37
III. Data Recording.....	40
IV. Data Analysis.....	43
RESULTS.....	45
I. Effects of Movement Amplitude on Duration of the Initial Agonist Burst (Agl).....	45
A. Change in Agl duration in normal subjects.....	45
B. Fine structure of Agl.....	58
C. Amplitude-dependent changes in Agl component magnitude.....	70
D. Changes in Agl duration in a deafferented patient.....	73
II. Effects of Peripheral Feedback on the Initial Agonist Burst.....	83
A. Effects of perturbations preceding movement on Agl.....	83
1. Changes in Agl magnitude and duration.....	83
2. Changes in Agl onset time.....	96
3. Effects of perturbations preceding small amplitude movements.....	100
B. Effects of starting position on the initial agonist burst.....	110
1. Baseline EMG correction.....	112
2. Changes in phasic EMG activity with different starting positions.....	116
3. Comparison of movement trajectories.....	129
4. Effects of changing equilibrium position on phasic EMG position.....	132
III. Phasic EMG Activity Associated with Changes in Movement Trajectory.....	133
DISCUSSION.....	153
I. Change in Agl Duration with Movement Amplitude.....	153
A. Results of previous studies.....	153
B. Fine structure of Agl.....	160
C. Central determination of Agl duration.....	161
II. Modulation of Agl by Peripheral Feedback.....	162
A. Effects of perturbations preceding movement onset.....	162

B. Modulation of Agl by changes in initial starting position.....	167
III. Relationship Between Phasic EMG Drive and Movement Trajectory.....	175
IV. Programming of the Initial Agonist Burst.....	178
SUMMARY.....	181
APPENDIX A.....	187
REFERENCES.....	188
VITA.....	199

LIST OF TABLES

Table		Page
1	Duration of the initial agonist burst associated with fast movements.....	56
2	Duration of the initial agonist burst associated with slow movements.....	57
3	Mean short and long duration initial agonist bursts across subjects.....	61
4	Percentage change in component duration with load and unload perturbations (slow movements).....	94
5	Percentage change in component duration with load and unload perturbations (fast movements).....	95
6	Range of initial agonist onset times relative to perturbation onset.....	99
7	Average response time for perturbed movements.....	101
8	Percentage difference in response time between perturbed and control large amplitude movements.....	102
9	Percentage difference in response time between perturbed and control small amplitude movements.....	111
10	Average peak velocity and movement duration values associated with movements made from different starting positions.....	119

✓

LIST OF FIGURES

Figure		Page
1	Temporal relationship between movement kinematic variables and voluntary EMG activity following application of brief force perturbations.....	35
2	Comparison of step and phase-plane tracking paradigms.....	39
3	Changing movement profile with phase-plane tracking.....	42
4	Distribution of initial agonist burst durations associated with fast flexion movements about the elbow.....	47
5	Distribution of initial agonist burst durations associated with slow flexion movements about the elbow.....	50
6	Changes in the proportion of short versus long duration initial agonist bursts with movement amplitude.....	52
7	Mean initial agonist burst durations associated fast and slow movements made at different movement amplitudes.....	55
8	Subject variability in mean initial agonist burst durations.....	60
9	Effects of movement amplitude on duration of the initial agonist burst.....	64
10	Intramuscular biceps EMG recordings associated with fast 40 deg flexion movements.....	67
11	Average agonist EMG activity associated with 50 deg slow movements.....	69
12	Initial agonist burst associated with fast extension movements about the elbow.....	72
13	Effects of movement amplitude on magnitude of the initial agonist burst during fast movements.....	75

14	Effects of movement amplitude on magnitude of the initial agonist burst during slow movements.....	77
15	Movements of different amplitudes made by a deafferented patient.....	80
16	Initial agonist burst duration in a deafferented patient.....	82
17	Effects of perturbations applied prior to movement onset.....	86
18	Dependence of EMG response on perturbation magnitude during slow movements.....	89
19	Dependence of EMG response on perturbation magnitude during fast movements.....	92
20	Typical onset times of the initial agonist burst relative to onset of brief force perturbations..	98
21	Average onset times of the initial agonist burst relative to perturbation onset.....	104
22	Effects of perturbations preceding small amplitude movements.....	107
23	Variability in initial agonist burst onset times relative to perturbation onset.....	109
24	Baseline correction of phasic EMG activity for position-dependent changes in tonic EMG activity.	114
25	Average peak velocities and movement durations for movements made from different starting positions.....	118
26	EMG activity associated with 10 deg slow flexion movements made from different starting positions.....	122
27	Dependence of phasic EMG magnitude on starting position of the limb.....	125
28	EMG activity associated with 40 deg slow flexion movements made from different starting positions.....	128

29	Movement trajectories associated with position-dependent changes in phasic EMG activity.....	131
30	Effects of changing passive limb equilibrium position on movement-related EMG activity.....	135
31	Effects of changing movement profile on phasic EMG activity.....	138
32	Effects of changing movement profile on duration of the initial agonist burst.....	142
33	Addition of initial agonist burst components with increasing movement ratio.....	145
34	Effects of changing movement profile on antagonist onset time.....	147
35	Effects of changing movement profile on late agonist activity.....	150
36	Dependence of late agonist activity on movement profile.....	152

INTRODUCTION

For many years a triphasic pattern of muscle activation was thought to be characteristic of only very rapid movements (Richer, 1895; Wachholder and Altenburger, 1926; Hallett et al., 1975a; Desmedt and Godaux, 1978; Hallett and Marsden, 1979; Ghez and Martin, 1982). This pattern consists of an initial burst of activity in the agonist muscle followed sequentially by a burst of antagonist activity and a second, more prolonged agonist burst. Recently, however, it has been shown that phasic activation of opposing muscles occurs over a wide range of single-joint, step-tracking movements which vary in both speed and amplitude (Hallett and Marsden, 1979; Brown and Cooke, 1981a).

It is generally accepted that the function of the initial agonist burst is to provide an acceleratory force responsible for overcoming limb inertia and thereby setting the limb in motion (Richer, 1895; Woodworth, 1899; Stetson and McDill, 1923; Angel, 1974; Hallett and Marsden, 1979). Several studies have shown that the magnitude of the initial agonist burst is strongly dependent on such movement parameters as amplitude and speed (Hallett and Marsden, 1979; Brown and Cooke, 1981a), limb inertia (Lestienne, 1979) and, in the case of isometric movements, peak force (Ghez and Vicario, 1978).

This initial burst of agonist activity is considered to be a centrally generated component of the triphasic EMG pattern. Studies in monkeys have shown that the discharge pattern of movement-related neurons in motor cortex parallels phasic activity in the agonist muscle (Lamarre et al., 1980). In addition, the initial agonist burst does not appear to depend on peripheral feedback since it is present in patients with peripheral sensory neuropathy (Hallett et al., 1975a; Rothwell et al., 1982; Forget and Lamarre, 1983) as well as in subjects experimentally deafferented by limb ischemia (Sanes and Jennings, 1984).

The extent to which the initial agonist burst represents a preprogrammed, unmodifiable component of the triphasic pattern is unclear. The results of numerous experiments (Hallett et al., 1975a; Freund and Budingen, 1978; Hallett and Marsden, 1979; Lestienne, 1979) have supported the widely held view that the duration of the initial agonist burst is a fixed parameter of the descending signal underlying movement initiation and thus represents an "invariant subunit" of the motor program (Lestienne, 1979). This apparent constraint on movement initiation is not restricted to isotonic movements but also holds for isometric contractions (Ghez and Vicario, 1978; Freund and Budingen, 1978; Sanes and Jennings, 1984). However, contrary to the accepted notion of constant initial agonist burst duration, Angel (1974) and Wadman et al. (1979) both reported that

burst duration increased with movement amplitude and inertial loading.

There is also conflicting evidence regarding the degree to which the initial agonist burst can be modified by peripheral input. Brief perturbations applied prior to movement onset do not appear to affect initial agonist burst duration (Hallett et al., 1975a; Hallett and Marsden, 1979). In addition, Garland and Angel (1971) and Hopf et al. (1973) found that unexpected peripheral disturbances such as tendon vibration or passive muscle shortening did not affect burst magnitude. Hallett and Marsden (1979), however, reported that initial agonist burst magnitude increased following passive muscle stretch and decreased following shortening.

Because of these conflicting views regarding programming and modification of the initial agonist burst, experiments were performed to answer the following questions: 1, is initial agonist burst duration constant over a wide range of movement amplitudes? 2, are both the magnitude and duration of the initial agonist burst affected by peripheral feedback? and 3, since it is generally assumed that the initial agonist burst provides the necessary force required to accelerate the limb, what is the precise relationship between the initial agonist burst and the acceleratory phase of the movement?

HISTORICAL REVIEW

I. Movement Classification

A. "Fast" versus "slow" movements

In 1923 Stetson and McDill described three general kinds of movements based on a detailed analysis of hand writing. The slowest of these were called fixation movements or the "movement of holding still". These movements, consisting of steady contraction of opposing muscles in order to maintain a given posture, gave rise to minute fluctuations in limb position, later referred to as physiological tremor. Slow or "controlled" movements consisted of alternating contraction of opposing muscles which produced fluctuations at 10-12 Hz. Each fluctuation or undulation was considered to be an independent element of the movement.

Fast movements were subdivided into two groups according to the degree of tension exhibited by the opposing muscles. Starting from a state of postural fixation, increasing the velocity of contraction in one muscle group produced "fast movements under tension". Although both muscle groups exerted force, it was the sudden increase in the rate of agonist contraction which initiated the movement. Fast movements which were characterized by an initial pulse of agonist activity followed by complete relaxation were termed

"ballistic" , borrowing from Richer's original definition of fast movements (Richer 1895).

In contrast to slow movements, fast movements consisted of only one undulation. In describing such movements, Stetson and McDill (1923) concluded that,

"For a path of given length a speed should be possible at which the entire movement shall be a single stretched out movement element..... the movement will now be a smooth curve, a single undulation. The control of the movement will depend on a single impulse in the one group of muscles which starts the movement and in the intervention of a second impulse, in the antagonist muscle group which stops the movement."

The concept of "fast" and "slow" movements has been expanded to cover a general description of eye movements.

Robinson (1968) described the two tracking functions performed by eye movements as the rapid acquisition of a given target followed by accurate tracking of the target as it moves relative to the environment. Rapid movements of the eye concerned with locating the target are called saccades and are influenced by information arising from the periphery only at discrete time intervals. Those movements involved in following the target are called smooth pursuit movements and require the continuous utilization of peripheral information concerning direction and velocity of the moving target. Although the saccadic and smooth pursuit systems are not the sole control mechanisms governing generation of eye movements, they do provide a further example of the distinction between fast and slow movements.

B. EMG activity associated with fast and slow movements

In addition to differences in kinematics, movements of different speeds can also be distinguished by their associated patterns of muscle activation. That the organization of fast movements differed from slow movements became evident when Wachholder and Altenburger (1926) described a triphasic pattern of electromyographic (EMG) activity during rapid movements. This pattern consisted of an initial burst of activity in the agonist muscle followed sequentially by a burst of antagonist activation and a second, more prolonged burst in the agonist. The antagonist burst coincided with a period of agonist inactivity, often referred to as the silent period. This phasic and reciprocally organized pattern of activation during rapid muscular contraction has since been confirmed by many investigators (Angel et al., 1965; Garland and Angel, 1971; Terzuolo et al., 1973; Hallett et al., 1975a; Hallett and Marsden, 1979; Brown and Cooke, 1981a).

In contrast to this highly stereotyped phasic pattern of EMG activity seen in fast movements, slow movements have been characterized by a lack of phasic EMG activity. Instead, continuous activation of either the agonist or both agonist and antagonist muscles is seen throughout the course of the movement. Simultaneous contraction of both agonist

7

and antagonist muscles observed in slow movements (Tilney and Pike, 1925; Wacholder and Altenburger, 1926) as well as in Stetson's "fast movements under tension" has been attributed to a demand for increased precision and rigidity during movement execution (Wilkie, 1950). The resultant increased stiffness would thus decrease the sensitivity of the limb to small deflecting forces. More recently, however, Hallett et al. (1975a) observed continuous activity in only the agonist muscle during slow flexion movements about the elbow.

C. Control mechanisms underlying fast and slow movements

The distinction between fast and slow movements is based not only on differences in speed and movement kinematics, but also on proposed control mechanisms underlying each type of movement. Stetson considered both types of fast movements to be "preprogrammed" in that the movement could not be altered by sensory feedback once it had begun. Such movements were thought to be modified only through changes in the initial "set" of the muscular system. In contrast, slow movements were thought to be continuously monitored and updated via peripheral feedback mechanisms (Stetson and McDill, 1923).

In the early 1970's the application of feedback and

feedforward principles became popular among motor behaviourists in describing separate control mechanisms for both fast and slow movements (Welford, 1968; Adams, 1971; Schmidt, 1972). By virtue of their strong dependence on peripheral information, slow movements were thought to represent a closed-loop, feedback control system. Rapid movements, on the other hand, were considered to represent a feedforward or open-loop mechanism. It has been suggested that such feedforward control systems operate at higher hierarchical levels in the central nervous system (Ito, 1970; Eccles, 1973; Kornhuber, 1974; Allen and Tsukahara, 1974). Thus, with learning there could be a gradual transition from closed loop mechanisms during slow movements to an open-loop, feedforward control of rapid, well learned movements. In addition to involvement in the control of fast, voluntary movements, it has also been proposed that the vestibular ocular reflex, involved in retinal stabilization, operates in a feedforward manner (Ito, 1974).

The widely accepted view of movements as being either "fast" or "slow" led Kornhuber (1971) to formulate an hypothesis concerning the underlying mechanism which controlled the two movement types. Observations stemming from disrupted saccadic eye movements in patients with cerebellar atrophy suggested that rapid movements, too fast to be monitored continuously, were controlled by the cerebellum. It was thought that the cerebellum was neces-

sary in "the translation of the spatial concept of the movement... into time" as reflected by the specific durations of phasic muscle activation associated with the movement. On the basis of movement deficits observed in patients with Parkinson's disease, Kornhuber hypothesized that the basal ganglia were essential in the execution of slow movements. While the cerebellum was considered to represent a clock mechanism involved in timing of muscle activity, the basal ganglia were thought to act as a ramp generator for slow, voluntary movement of the hand, limbs and trunk.

The role of the cerebellum as proposed by Kornhuber has since been clarified and expanded to include a broader range of movement velocities. Both experimental and clinical observations clearly implicate the cerebellum in the initiation of movement as well as regulating the timing of reciprocal muscle activity associated with a given motor task (Holmes, 1922; Meyer-Lohmann et al., 1977; Lamarre and Jacks, 1978). Neurons in the dentate nucleus of the lateral cerebellum discharge well before movement onset and before onset of neurons in motor cortex to which they project (Thach, 1975; Thach, 1978). The cerebellum is also thought to be involved in determining the pattern and force of muscle activity (Thach, 1978) as well as movement velocity (Burton and Onoda, 1977, 1978). Recently, Schieber and Thach (1985) have shown that, during slow ramp movements in

monkeys, neurons in both dentate and interpositus nuclei exhibited either an abrupt increase or decrease in firing frequency at or before the onset of movement. This change in activity was maintained throughout the ramp movement and was independent of movement direction. In addition, the discharge patterns of movement-related cells in motor cortex and dorsal root ganglia paralleled cerebellar activity. These observations have led Thach to suggest that, during slow, continuous tracking movements, the cerebellum maintains muscle spindle sensitivity via the gamma system so as to continuously monitor small movement irregularities such as tremor.

Recent studies have also shown that the basal ganglia may play a more active role in movement generation than originally hypothesized by Kornhuber. Following Flowers' (1975) observation that Parkinson patients produced movements of large amplitude by a series of small amplitude movements, Hallett and Khoshbin (1980) found that such movements were the result of several alternating cycles of phasic agonist and antagonist activity. This continuous bursting pattern appeared to result from the inability to adequately increase the magnitude of the initial drive to the agonist muscle as would be expected in normal subjects. Hallett argued that, contrary to Kornhuber's hypothesis, the basal ganglia are involved in the programming and execution of rapid movements. This view has been supported by

single unit studies in which discharge of putamen and pallidal neurons have been found to be related to both direction and amplitude of the movement' (Georgopoulos et al., 1983; Crutcher and DeLong, 1984).

Hore and Vilis (1980) found that reversible cooling of the basal ganglia in monkeys produced major disorders in the execution of prompt elbow movements. This included slowing of movement and rebound of the arm towards its initial position after movement onset. These disturbances in movement generation were accompanied by earlier onset, increased magnitude and prolongation of antagonist activity as well as an increase in agonist activity. This led to the suggestion that the basal ganglia are also involved in achieving "the correct balance of activity between agonists and antagonists that is appropriate for a particular motor act." The basal ganglia have also been implicated in the control of saccadic eye movements (Hikosaka and Wurtz, 1983), movement facilitation (Hallett and Koshbin, 1980) and in the execution of complex motor acts (Stern et al., 1982).

II Triphasic EMG Pattern

The triphasic EMG pattern was, for many years, thought to be characteristic of only very rapid, so-called "ballistic" movements (Richer, 1895; Wachholder and Altenburger,

1926; Hallett et al., 1975a; Desmedt, 1978; Hallett and Marsden, 1979). More recently, however, it has been shown that phasic agonist and antagonist EMG activity occurs in a wide spectrum of simple, step-tracking movements which vary in both speed and amplitude (Hallett and Marsden, 1979; Brown and Cooke, 1981a).

A. Function of phasic muscle activity

The precise role of the various components comprising the triphasic EMG pattern is not fully understood. Since Woodworth's notion of the "initial impulse" in 1899, it has been generally accepted that the function of the initial agonist burst is to overcome limb inertia and set the limb in motion (Richer, 1895; Woodworth, 1899, Stetson and McDill, 1923; Angel, 1974; Hallett and Marsden, 1979). It is not surprising then, that the magnitude of the initial agonist burst has been shown to be strongly dependent upon movement amplitude and speed (Hallett and Marsden, 1979; Brown and Cooke, 1981a) limb inertia (Lestienne, 1979; Benecke et al., 1985) and, in the case of isometric movements, on peak force (Ghez and Vicario, 1978).

It is generally presumed that phasic antagonist activity provides a counteractive braking force which decelerates the limb (Terzuolo et al., 1973; Angel, 1977; Lestienne, 1979; Marsden et al., 1983; Flament et al., 1983). Timing and

magnitude of the antagonist burst depends not only on movement amplitude and speed (Brown and Cooke, 1981a; Marsden et al., 1983; Flament et al., 1983) but also on limb inertia (Lestienne, 1979; Flament et al., 1983; Meinck et al., 1984). There are instances, however, where phasic antagonist activity is not present. For example, in relatively slow movements, the visco-elastic properties of the muscles involved may be sufficient to terminate the movement (Stetson and McDill, 1923; Lestienne, 1979; Marsden et al., 1983; Flament et al., 1983).

The role of the second agonist burst is less clear. It has been suggested that late agonist activity reflects enhanced gamma drive which serves to increase muscle spindle sensitivity following muscle contraction (Alston et al., 1967; Angel, 1974). The resultant change in muscle sensitivity coupled with a reduction in the amount of Golgi tendon organ inhibition during the decelerative phase of the movement was thought to facilitate activation of the alpha motoneuronal pool (Angel, 1974).

Late agonist activity has been attributed to reflex mechanisms engaged when, during the terminal phase of the movement, a transient reversal in limb direction occurred (Ghez and Martin, 1982). Stretch induced activation of the agonist would thus act as a damping mechanism to stabilize the limb in its final position. Meinck et al. (1984) have also suggested that the second agonist burst is involved in

stabilization of the limb but that it is a centrally determined component of the triphasic pattern. Wadman et al. (1979) considered late agonist activity to be a centrally determined component of the descending command signal which "partly compensates for the antagonist rest force, bringing the movement more rapidly to a stop".

B. Generation of the triphasic pattern

Despite the ubiquitous nature of a triphasic or biphasic pattern of muscle activation, the extent to which it is centrally programmed is still a matter of controversy. There is little doubt that at least the early part of the initial agonist burst is centrally generated. The onset of the initial agonist burst in both isotonic and isometric movement precedes movement onset by 40-50 ms and thus cannot be the result of stretch reflex activity. Experiments in deafferented monkeys have shown that movement-related neurons in motor cortex continue to exhibit a phasic discharge pattern despite the absence of peripheral feedback (Lamarre et al., 1980). Burst duration of some cortical neurons is similar to the duration of the initial agonist burst and precedes muscle activity by 50-60 ms. Generation of the antagonist burst, however, is still a matter of debate. Angel (1977) observed that mechanical blocking immediately prior to the onset of rapid movements about the

shoulder reduced the magnitude of the antagonist burst. Since some degree of antagonist activity persisted in the blocked movements, it was postulated that antagonist activity during movement was the result of a central motor program which can be modulated by peripheral feedback. Ghez and Martin (1982) suggested that early phasic antagonist as well as the second agonist burst resulted from stretch reflex activity. This conclusion was based on the results of isometric tracking experiments in cats where antagonist and late agonist activity did not occur unless the limb was displaced by unexpected unloading. It has recently been shown, however, that in humans, isometric contractions about the wrist are associated with a triphasic pattern of muscle activation (Sanes and Jennings, 1984). In addition, subjects with severe pan-sensory neuropathy (Hallett et al., 1975a; Rothwell et al., 1982; Forget and Lamarre, 1983) or experimentally induced nerve block (Sanes and Jennings, 1984) also show a triphasic EMG pattern when performing rapid flexion movements about the elbow. Thus, at least in humans, it would appear that the presence of alternating bursts of agonist - antagonist activity does not depend on either actual limb movement or afferent feedback.

In support of the notion that the triphasic pattern is centrally determined, there have been several studies which have implicated the cerebellum in the generation of the initial agonist and antagonist bursts. Terzuolo and Viviani

(1973) found that patients with cerebellar dysfunction failed to exhibit clearly defined bursts of EMG activity associated with rapid arm movements. The absence of structured and reciprocally related phasic activity in these patients led to the conclusion that the normal generation of both the initial agonist and antagonist bursts were under cerebellar control. Prolongation of both these bursts was observed by Hallett et al. (1975b) in cerebellar patients performing rapid movements about the elbow. Prior to the beginning of agonist activation, activity in the antagonist ceased too late if at all, again suggesting cerebellar involvement in the timing of reciprocally organized phasic EMG activity.

III Control of Movement Trajectory

The acceleratory and deceleratory forces generated by a stereotyped sequencing of phasic muscle activity will determine movement trajectory or the path the limb assumes when moving from one position to another. For many years, characteristics of movement-related velocity and acceleration profiles were used to describe trajectory. Woodworth (1899) distinguished an acceleratory phase, a period of constant velocity and a deceleratory phase for movements of the hand toward a target. Following Woodworth's descrip-

tion, several investigators reported that, for similar pointing movements, duration of the acceleratory and deceleratory phases varied with movement amplitude and the degree of accuracy required (Peters and Wenborne, 1936; Taylor, 1947; Taylor and Birmingham, 1948; Vince, 1948; Annett et al., 1958; Edwards, 1965). In these studies it was found that the time spent in decelerating the limb was, in most cases, longer than the time spent in movement acceleration. Beggs and Howarth (1972) reported that, in similar pointing tasks, the associated movement velocity profiles depended on both speed and practice. The duration of the deceleratory phase decreased with practice and increased speed so that, for well learned movements, the velocity profiles were symmetrical.

More recently, considerable interest has been focussed on the control of trajectory associated with multi-joint movements. For pointing movements involving the shoulder and elbow joints, Soechting and Lacquaniti (1981) showed that hand trajectory (derived from position of the wrist in three dimensional space) varies little from trial to trial and is independent of movement speed. In addition, angular velocities of the shoulder and elbow are linearly related to each other as the final target is approached. These findings led to the suggestion that movement trajectory is an invariant property of the movement and thus is planned and regulated by the central nervous system. Further-

more, experiments in both primates (Georgopoulos et al., 1981) and humans (Soechting and Lacquaniti, 1983) have shown that movement trajectories can be modified throughout the course of the movement, suggesting that "the aimed motor command is emitted in a continuous, on-going fashion as a real-time process that can be interrupted at any time..." (Georgopoulos et al., 1981).

Most of the studies concerned with trajectory formation have examined complex movements requiring coordinated movement about two or more joints. For single joint movements, little is actually known about the control of movement time profiles (i.e. the relationship between position and velocity referred to as movement trajectory; cf. Cooke, 1980) other than the widely accepted view that such movements are characterized by highly symmetrical velocity profiles. Hand velocity profiles associated with multi-joint movements have also been found to be bell shaped and symmetrical in appearance (Georgopoulos et al., 1981; Morasso, 1981; Abend et al., 1982), suggesting that symmetrical velocity profiles are a common feature of all movements and, as such, may represent the most efficient means of producing a given movement trajectory (Nelson, 1983).

As mentioned earlier the force generated by activation of the agonist and antagonist muscles will clearly affect the trajectory of the movement. This has recently been

demonstrated by isometric force tracking tasks in cats (Gordon and Ghez, 1984). In movements of comparable durations, phasic agonist and antagonist activity varied with changes in the rate of rise of force. In movements with long force rise times, agonist activity continued throughout the rising force phase and no phasic antagonist burst occurred. This was in sharp contrast to short rise time movements in which the initial agonist burst was of large amplitude and limited duration. These latter movements were also characterized by phasic activation of the antagonist.

It has also been suggested that the role of stretch reflex activity during movement is to maintain intended movement trajectory in the face of peripheral disturbances. Cooke (1980) has shown that, for a certain range of movement velocities, brief load perturbations applied during the course of step-tracking elbow movements result in reflex responses which act to return the limb to its intended path. Maintenance of intended limb trajectory has also been demonstrated for movements which are briefly unloaded via activity of the unloading reflex (Cooke and Spencer, 1984).

IV Control of Final End Position

While variations in the pattern of phasic EMG activation

will determine the dynamics of the movement, the achievement of final limb position is thought to represent a separate neural process involved in movement generation. There are both theoretical and experimental studies which suggest that achievement and maintenance of final position is determined by direct regulation of the length-tension characteristics of the muscles involved. This view is premised on the observation that muscles behave like damped springs where muscle force varies as a function of its length (Ralston et al., 1947; Gordon et al., 1966).

Crossman and Goodeve (1963) first put forth the idea that movements about a joint are the result of shifts in the length - tension curves of opposing muscles. The limb would be at equilibrium at the point of intersection of the length - tension curves of the relevant muscles. At this position the net forces acting about the joint are equal and opposite and no movement of the limb would occur. An equilibrium point hypothesis developed by Fel'dman (1966, 1974a,b) was later supported by experiments on vestibulectomized and deafferented monkeys (Bizzi et al., 1976; Polit and Bizzi, 1979). In these studies, it was found that, in learned tracking movements, brief perturbations of the initial head or arm position did not prevent attainment of the intended target position. This was taken as evidence for central programming of tonic agonist and antagonist muscle activity which, in turn, would reset the relevant

muscle length-tension curves and thereby specify a new equilibrium point.

Day and Marsden (1982), however, have recently shown that, at least for rapid flexion movements of the human thumb, central resetting of tonic agonist and antagonist activity is not the sole mechanism in determining final end position. Unexpected changes in viscous force did not affect terminal accuracy of non-visually guided movements. However, changes in viscous force when joint and cutaneous afferent feedback was removed by ring block anaesthesia resulted in significant errors in final position. The magnitude and direction of the error was related to both the size and direction of the change in viscous friction. Since anaesthesia reduced stretch reflex responses evoked by viscous loading, it was concluded that, for rapid thumb movements, determination of final position was achieved through the use of a closed feedback loop.

Sanes and Evarts (1983) examined the effects of briefly blocking or reversing human elbow movements on end point error. It was found that the error in final position was proportionally greater for small as compared to large movements. This observation led to the conclusion that the "size of movement is a critical variable in determining whether the central signal to the muscles is adequate to specify the end point for the limb."

The mass spring model has, for the most part, been

implicated only in the control of final position. It has recently been shown, however, that movement trajectory may be determined by a series of changes in muscle length tension properties. In experiments on deafferented monkeys where the arm position was displaced from its normal trajectory, Bizzi et al. (1984) found that the arm did not return to either the initial or final position but rather moved to points intermediate between them. This led to the suggestion that "the alpha motoneuronal activity specifies not only a position for the forearm at equilibrium.... but also a series of equivalent equilibrium positions throughout the movement". Based on a mathematical analysis of movements such as those studied by Bizzi et al (1984), Hogan (1984) has developed the concept of "virtual position" to describe the time history of equilibrium positions generated during movement. In both Bizzi's experiments and Hogan's model, movement trajectory was the result of a gradual shift in equilibrium position. However, Cooke and Brown (1985) have shown that, for some movements about the human elbow, movements can be produced by a rapid resetting of final equilibrium position which occurs very early in the movement.

V Initial agonist burst and movement initiation

A. Evidence for central programming

Over the past few years considerable interest has been focussed on the mechanisms involved in movement initiation. The results of several studies in both humans and animals have suggested that the signal for movement initiation is, to a large extent, centrally preprogrammed and unmodifiable by peripheral influences. This notion of preprogramming developed primarily as a result of experiments in which the duration of the initial agonist burst remained unchanged under different movement conditions. Hallett and Marsden (1979) found no change in the duration of the initial agonist burst associated with rapid thumb movements despite differences in movement amplitude, initial starting position and background torque. For movements about the elbow, changes in movement amplitude (Brown and Cooke, 1981a) or limb inertia (Lestienne, 1979) were found to have no effect on initial agonist burst duration. Similar findings have been found for finger movements made at different amplitudes (Freund and Budingén, 1978). As a result of these observations duration of the initial agonist burst has been thought of as an "invariant subunit" of the motor program (Lestienne, 1979). To produce movements of different speeds and amplitudes, the central nervous system appeared constrained

to modulate burst magnitude over a fixed period of time. This apparent constraint is not restricted to isotonic movements but also holds for isometric contraction both in cats (Ghez and Vicario, 1978) and humans (Freund and Budingen, 1978; Gordon and Ghez, 1984; Sanes and Jennings, 1984). In the latter case, however, the duration of the initial pulse is somewhat longer in isometric versus isotonic movement about the same joint (Sanes and Jennings, 1984).

The above findings suggested that the descending signal governing movement initiation is of constant duration and variable amplitude. The degree to which this pulse of activity can be modified by peripheral input is unclear. Hopf et al (1973) reported that tendon vibration and direct electrical stimulation of either the agonist or antagonist muscle had no effect on the initial agonist burst associated with movements about the human elbow. In addition, it was observed that a segmental stretch reflex could only be elicited up to 40-50 ms before the onset of the initial agonist burst. Garland and Angel (1971) found that unexpected shortening of the agonist muscle prior to shoulder adduction did not affect initial agonist burst magnitude. Later studies by Hallett et al. (1975a), however, showed that passive extension of the elbow prior to elbow flexion did increase magnitude of the initial agonist burst.

The sensitivity of thumb muscles to peripheral feedback

has been extensively examined by Marsden. Perturbations timed to occur between the signal to move and the onset of the initial agonist burst modified agonist activity in a load dependent manner (Hallett and Marsden, 1979). Reflex increases in initial agonist burst magnitude occurred following passive muscle stretch while a decrease in activity occurred following muscle shortening. More recently, Gielen et al. (1984) examined the effects of an unexpected change in final target position on movement-related EMG activity. On random trials, movement of the target occurred in two steps prior to movement onset with an interstimulus interval of 50-125 ms. When the second target movement resulted in a doubling of the control target distance, both duration and magnitude of the initial agonist burst increased.

Although most of the above findings strongly support the notion that the descending signal governing movement initiation is of constant duration and variable amplitude, there were brief reports in two studies which questioned this view. In 1974, Angel reported that, for adduction of the shoulder, duration of the initial agonist burst increased with movement amplitude as well as with inertial loading. More recently, Wadman et al (1979) observed that agonist burst duration associated with rapid extension movements of the wrist doubled over a range of movement amplitudes. Inertial loading of the wrist for movements of

a given amplitude was also found to increase burst duration.

B. Movement control theories

Despite these contradictory findings regarding initial agonist burst duration, there has been widespread acceptance of the view that the duration of the initial agonist burst represents an invariant characteristic of the motor command. Based on the observation that voluntary contraction time remained constant across different movement conditions, Freund and Budingen (1978) developed a speed control hypothesis to explain how movements were generated. The speed control system was thought to operate by "amplitude-dependent regulation of contraction velocity so that the contraction time remains constant." More importantly, the fixed duration of the initial agonist burst was considered responsible for maintaining a constant time to peak velocity with modulation of burst magnitude effecting changes in speed of contraction. Lestienne (1979) extended the speed control hypothesis to include not only central determination of initial agonist burst duration but also onset of phasic antagonist activity.

More recently, the speed control hypothesis has been reexamined for multidirectional movements about the knee (Enoka, 1983). (As pointed out by Enoka the term "speed" control is somewhat misleading since it is duration rather

than speed which is suggested to be the controlled variable). It was found that in weightlifting movements the duration of the initial extension phase was not affected by different inertial loads. The second flexion phase, however, was of variable duration depending on both load and degree of skill in performing the task. Thus Freund and Budingen's proposed speed control system does not appear to be the only mechanism involved in the regulation of more complex movements.

The results of isometric force tracking in cats led Ghez to propose a "pulse-step" model of motor control in which the dynamic phase of the movement was controlled by "an initial phasic control signal of variable amplitude and limited duration". (Ghez and Vicario, 1978). In these experiments initial agonist burst magnitude increased with increasing rates of force change. Since burst duration did not change it was concluded that the initial agonist burst was part of a preprogrammed control signal "the magnitude of which varied with the rate of force change, the duration, however, being independent of both final force achieved and the rate of force change." (Ghez and Martin, 1982). The step component of the model represented the change in tonic EMG drive responsible for final force level in the case of isometric movements and final position in isotonic movements.

Pulse-step models are not unique to the understanding of

limb movements. Robinson (1968) proposed such a mechanism to explain the control of saccadic eye movements. In this case, however, the controlled variable was pulse width rather than pulse amplitude. Since oculomotor neuronal burst discharge occurs at near maximal frequency and persists throughout the duration of the saccade, regulation of burst duration determines the size of the saccadic movement. Although both limb and eye movements can be characterized by pulsatile activity in the agonist muscle, regulation of this activity appears to be quite different in the two systems. This may be partly related to very large differences in such physical properties as inertia.

While it appears that duration of the initial agonist burst is kept constant under a variety of conditions, the central nervous system does not appear to be able to accurately program burst magnitude. Schmidt et al (1979) examined rapid movements of a hand held stylus toward a target and found that the variability in movement end point error increased with increasing movement amplitude. Schmidt proposed an "impulse variability" theory which predicted that variability in end point error was linearly related to variability of the initial impulse (i.e. the initial agonist burst). It was suggested that increased variability associated with larger force outputs might reflect random noise in the neuromuscular system due, in part, to variability in the recruitment of additional motor units.

METHODS

I General

A. Normal Subjects

Experiments were performed on thirteen male and two female normal subjects with no known history of neurological disorders. Thirteen of the subjects were right handed and two were left handed. Approval for all procedures was obtained from the university standing committee on human experimentation. All subjects performed alternate flexion-extension movements about the right elbow. Subjects were seated comfortably and grasped a vertical rod attached to a manipulandum handle (Thomas et al., 1976). The subject's arm was positioned so that the elbow was beneath the pivot point of the handle which was free to move horizontally. The shoulder was abducted to approximately 90 degrees (deg). The arm was supported just distal to the elbow. During the experiments the subject was required to make visually guided step-tracking movements. The target to be followed was displayed as a vertical bar on an oscilloscope positioned about 1 meter in front of the subject. Target width was indicated by the width of the bar. The targets

were not mechanically detectable and were not bounded by mechanical stops. Target position switched at a regular rate (every 4 sec) between two fixed positions. Also displayed (as a vertical line) was the handle position derived from a precision potentiometer placed at the pivot point of the handle. Using flexion-extension movements, subjects were required to superimpose the handle cursor on the target bar. Forces could be delivered to the handle by a linear torque motor mounted at the axis of handle rotation. (See Thomas et al. (1976) for a description of motor characteristics). Each subject was allowed several minutes to practice the movements before actual experimental trials began.

B. Deafferented patient

Experiments were performed on a thirty-six year old female who had been functionally deafferented for a period of five years following a Guillain-Barre episode and a second episode of polyneuropathy. Clinically, she exhibited a total loss of touch, vibration, pressure and kinesthetic senses. No tendon reflexes were present in the four limbs. The trunk was moderately affected. Pain and temperature sensation were present, indicating selective impairment of the large diameter peripheral sensory myelinated fibers. Clinical testing indicated that motor fibers were not affected. Motor nerve conduction velocity was normal while

no sensory potentials could be recorded in the four limbs. H-reflexes were absent in the legs and there was no cortical response evoked by electrical stimulation of peripheral nerves of either arms (Forget, 1986). Results of a sural nerve biopsy revealed a severe loss of large myelinated fibers: fibers larger than 6.5 μ m represented only 1.6% of the total number of fibers examined.

The subject performed flexion-extension movements as described above. In addition, the subject's view of her arm was blocked by a sheet. As the subject had no kinesthetic sensation, it was necessary to strap her hand to the handle so she did not inadvertently let go of it during the experiment.

II Experimental Paradigms

A. Effects of movement amplitude on initial agonist burst duration

Experiments were performed on eight male subjects ranging from twenty-two to fifty-eight years in age. During each experimental session the subject was asked to make a series of step-tracking movements about the right elbow. Each trial consisted of thirty to forty alternating flexion-extension movements during which the subject was to follow the target. In experiments on normal subjects two instruc-

tion sets were used. In one, subjects were to produce "fast" movements in which the emphasis was placed on speed. In the second, accuracy in reaching the final target position was stressed. In any given trial, movement amplitude (ranging from 5 to 50 deg of arc) remained constant. Initial starting position was kept constant at 105 deg (where 180 deg was equivalent to full extension) from trial to trial. Movement amplitude and instruction were randomized from trial to trial. The task was not a "reaction time" task; the subject was not required to minimize his/her reaction time to target movement.

In the deafferented patient study, the subject was instructed to move "at her own speed" and, again, no restrictions were placed on reaction time. Movement amplitude ranged from 6 to 60 deg of arc. Targets were symmetrically located about an elbow angle of approximately 90 deg.

B. Role of peripheral feedback on the initial agonist burst.

1. Effects of perturbations preceding movement on the initial agonist burst.

Experiments were performed on three male and two female subjects ranging in age from twenty-two to forty-two years.

In the first set of experiments subjects were asked to make a series of 30 deg movements. Each trial consisted of forty alternating flexion-extension movements during which the subject was required to follow the target either as "fast as possible" or to move "slowly and accurately". In any given trial, brief (50 ms) torque pulse perturbations were applied to the handle on randomly selected movements. The timing of the perturbations relative to the target and movement-related EMG activity is indicated in Fig. 1. Perturbations were applied 50 ms following a switch in target position (Fig. 1B,C). Because of variability in the time at which the subject responded to the changes in target position, the perturbation preceded movement onset by variable times from movement to movement. In all cases the perturbation occurred prior the onset of movement-related EMG activity (Fig. 1B,C - agonist EMG-stippled area). During any experimental session, perturbation magnitudes ranged from 1.0 to 5.0 Nm and either opposed (Load - Fig. 1B) or assisted (Unload - Fig. 1C) the forthcoming movement. Subjects were asked to disregard whatever limb displacement might occur because of the perturbation (i.e. not to correct for the displacement before moving to the new target position) and to concentrate on tracking the target according to the instruction given. Several minutes of practice were allowed prior to data sampling.

In the second set of experiments, movement amplitude was

Figure 1

Temporal relationship between movement kinematic variables and voluntary EMG activity following application of brief force perturbations. In each set of data (A - C) are shown individual records of target position, torque, handle position, velocity, agonist (biceps) and antagonist (triceps) EMG activity. Brief, 50 ms torque pulses could be applied at variable times following a change in target position which either opposed movement (B - load) or assisted movement (C - unload). Loading pulses resulted in a downward displacement of both position and velocity records while unloading pulses produced upward displacements. In both control (A) and perturbed (B,C) movements, phasic agonist EMG activity (stippled area) was associated with movement initiation. Vertical dashed lines in each set of records indicate the onset and termination of both components comprising the initial agonist burst (Agl_a, Agl_b). Vertical calibration bar: 20 deg; 100 deg/s; horizontal calibration bar: 200 ms.

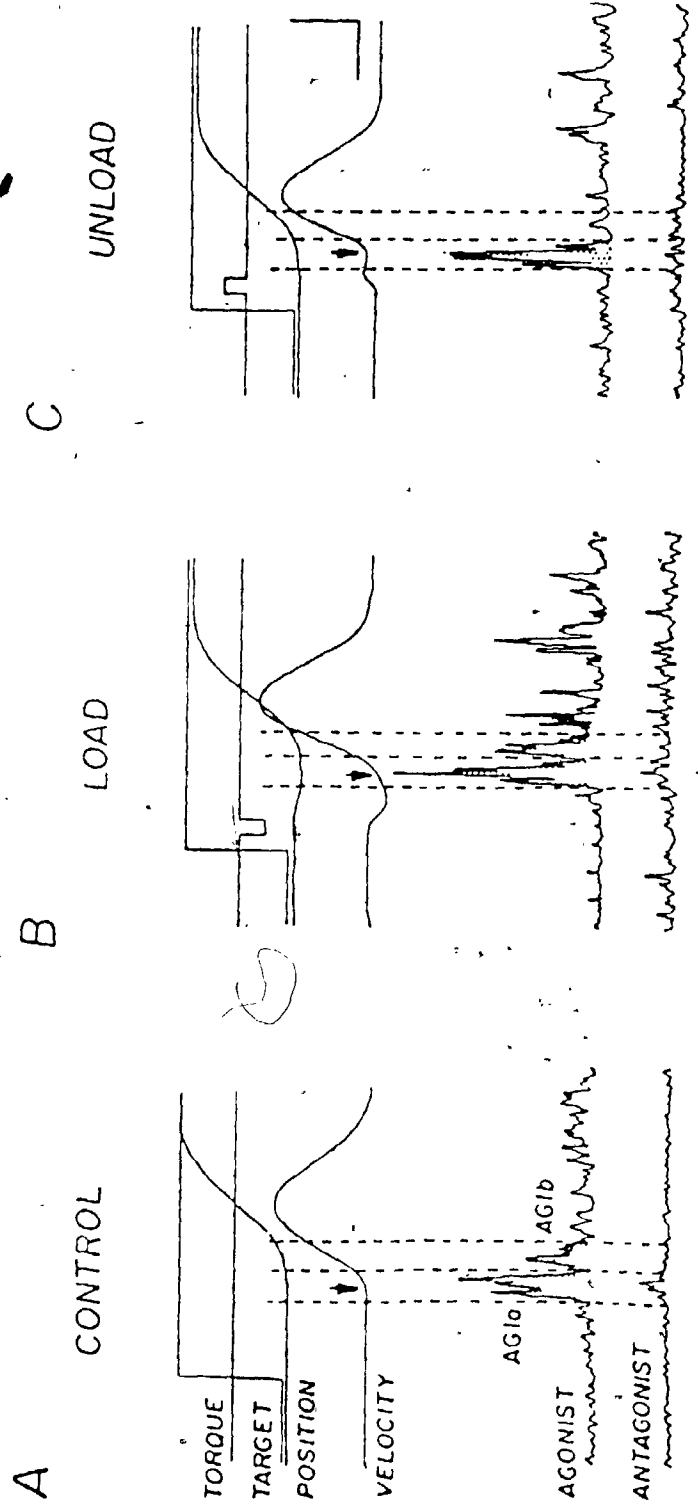

A

B

C

CONTROL

LOAD

UNLOAD

TORQUE

TARGET POSITION

VELOCITY

AGONIST

ANTAGONIST

AGIa

AGIb

reduced to 15 deg and each subject was asked to make movements "slowly and accurately". Perturbations were again timed to occur following a switch in target position but before the onset of movement-related EMG activity. In these experiments perturbation magnitudes ranged from 1.0 to 5.5 Nm.

2. Effects of initial starting position on the initial agonist burst.

Experiments were performed on five male subjects ranging in age from twenty-two to forty-four years. In these experiments each trial consisted of forty alternating flexion - extension movements in which subjects were asked to move "slowly and accurately". In the first set of experiments, intertarget distance was kept constant at 10 deg of arc with initial joint angle (starting position) ranging from 65 to 125 deg (180 deg equivalent to full extension). In the second set of experiments, intertarget distance was set at 40 deg of arc with initial joint angle ranging from 85 to 135 deg. Starting positions were randomized from trial to trial. Subjects were encouraged to maintain the same speed across all trials and several minutes of practice were allowed prior to data sampling. In certain trials, a small steady load was applied which moved

the subject's relaxed arm into an extended position. The load was adjusted so as to change the resting limb equilibrium position from approximately 80 - 90 deg (Cooke and Brown, 1983; Lestienne et al., 1981) to a new equilibrium position of 125 deg. Following this, the subject was asked to track the target in the manner described above while the steady force remained on.

C. EMG activity associated with asymmetric movement profiles

In this set of experiments, four subjects were asked to reproduce a template of the desired movement by appropriate movement of the handle. The movement template, displayed to the subject on an oscilloscope, was a phase-plane representation (Cooke, 1980a,b) in which arm velocity was displayed as a function of arm (handle) position during the movement (Cooke and Brown, 1986). Figure 2B illustrates averaged movements made using this phase-plane tracking technique. For comparison, records from averaged movements performed with a step-tracking paradigm (see Methods I) are shown in Fig. 2A. Movements made using both paradigms were qualitatively similar and displayed typically symmetrical movement velocity profiles in which the time spent accelerating and decelerating the limb was approximately equal. Phase-plane tracking, however, appeared to produce movements which were less variable than movements produced by step-tracking.

Figure 2

Comparison of step and phase-plane tracking paradigms.

Average records of arm position and velocity are shown from movements made with step tracking (A) and phase plane tracking (B) displays. Each record is the average of 10 movements with the bars indicating the standard deviations. Movements were averaged about movement onset (vertical dashed line). Average movement phase planes where velocity (vel) is plotted as a function of position (pos) are shown below the time plots. Arrows indicate direction of movement from an extended (X) start position to a flexed end position (F). In both conditions movement amplitude was 50 deg and movement duration was approximately 600 ms. For the phase plane tracking the ratio of acceleration to deceleration durations was set at 1.0.

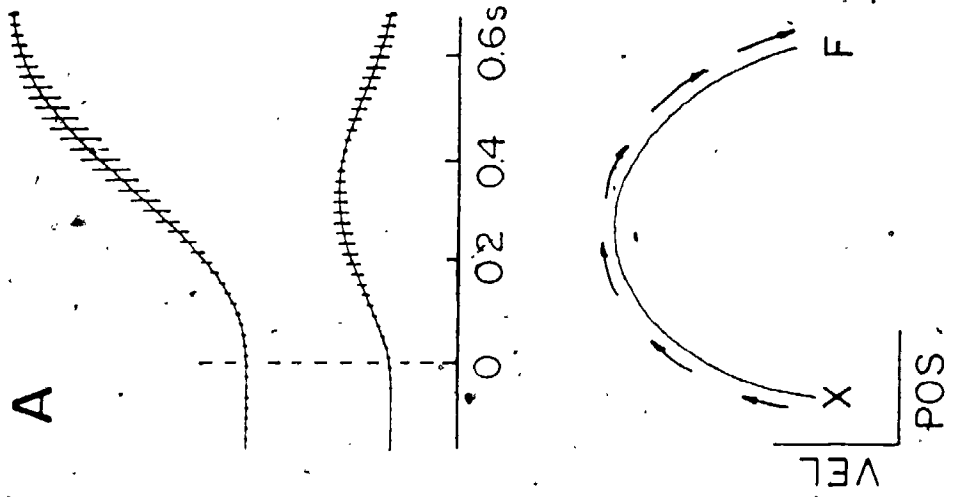
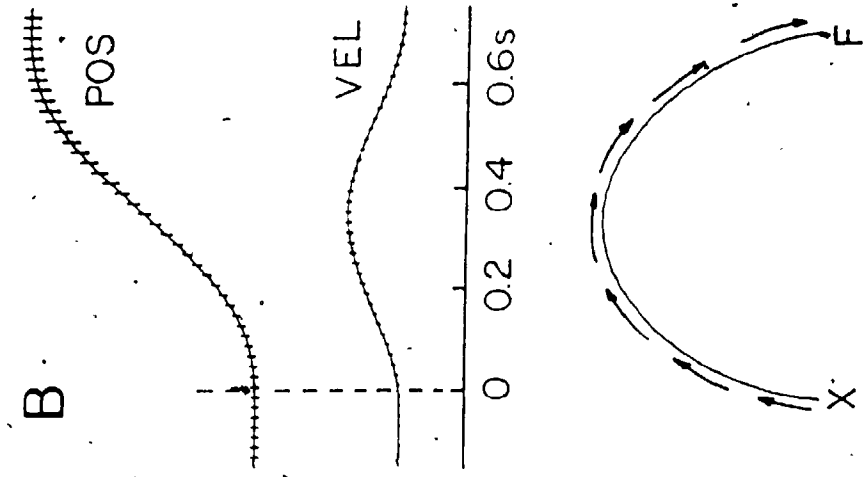

In order to produce movements with asymmetric velocity profiles, the ratio of acceleration to deceleration durations was varied while movement start and end positions, movement duration and movement peak velocity were kept constant. Typical examples of small (A) and large (B) amplitude movements made with different acceleration-deceleration ratios are shown in Fig. 3. Using this technique subjects were also able to produce movements of the same amplitude and acceleration-deceleration ratio, but of different durations (Fig. 3C).

III Data Recording

In all experiments, primary data recorded were the angular position and velocity of the manipulandum handle and the surface electromyograms (EMGs) from biceps brachii and the lateral head of triceps brachii. In addition, intramuscular biceps recordings were obtained in two subjects. Handle position and velocity were obtained from a precision potentiometer and tachometer. Surface EMGs were recorded with disk electrodes, 0.8 cm in diameter, spaced 2-3 cm apart over the muscle belly. For intramuscular recordings, bipolar platinum wire electrodes, 0.07 mm in diameter (Disa, 13K71) were inserted into the belly of the biceps muscle with a removable stainless steel cannula. The recording surface was restricted to the cut ends of the

Figure 3

Changing movement profile with phase-plane tracking.

In A and B are shown average velocity records of movements of different amplitudes (A-10 deg; B-60 deg). The ratio of acceleration to deceleration durations was varied as indicated at the left. Desired movement duration was 800 ms. All records were aligned about movement onset (vertical dashed line) for averaging. Each record is the average of ten movements with the bars indicating the standard deviations. In C are shown records of movements of the same amplitude (60 deg) and symmetry (acceleration/deceleration ratio equals 1.0) but of different durations. Averaging as in the other records. Vertical calibration bar indicates 20, 75 and 150 deg/s for A, B and C respectively.

U

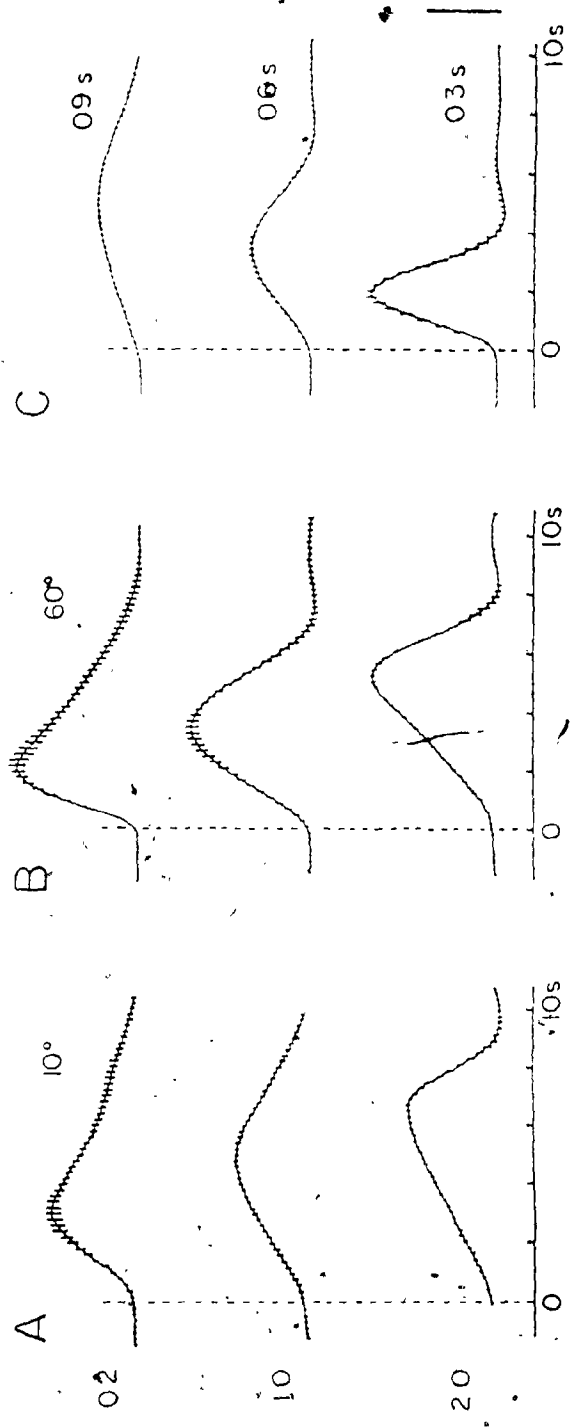

wires. Surface and intramuscular EMGs were filtered (low frequency cutoff - 20 Hz, high frequency cutoff - 2000 Hz) and the surface EMGs full wave rectified before recording.

Position, velocity and surface EMG data were digitized on-line using a PDP 11/44 computer system with an effective sampling rate of 500 Hz. Data were collected on disk and transferred to magnetic tape for later off-line analysis and archiving. Multi-unit intramuscular recordings were collected on analog tape (Racal Store 7DS FM recorder) and simultaneously displayed on an oscilloscope and chart recorder (Gould ES1000).

IV Data Analysis

In general, records of data from each flexion and extension movement were plotted for study. In some cases, EMG data was digitally filtered (20-100 Hz cutoff, zero phase shift) before plotting. All movements studied, both "fast" and "slow", were initiated by a distinct phasic agonist burst. Fast movements were not equivalent to the fastest movements possible (ballistic) nor did slow movements represent ramplike movements which are generally characterized by continuous EMG activity (cf. Hallett et al., 1975a). Timing of phasic agonist EMG activity was determined by visual inspection of individual records (Hallett and Marsden, 1979; Gottlieb and Agarwal, 1980).

This is shown, for example, in Fig. 1A where timing of the initial agonist burst is indicated by the vertical dashed lines. (In this figure Agl is shown to consist of two periods of activity, Agla, Aglb. This is described in detail in Results I). The initial agonist burst was defined as beginning approximately 40-50 ms prior to movement onset (arrow - Fig. 1A) and ending before peak velocity was reached (cf. Hallett et al., 1975a).

RESULTS

I. Effects of movement amplitude on duration of the initial agonist burst (Agl).

A. Change in Agl duration in normal subjects.

Previously, it had been reported that, for human thumb (Hallett and Marsden, 1979) and elbow (Lestienne, 1979; Brown and Cooke, 1981a) movements, the duration of the initial agonist burst (Agl) did not change under different movement conditions. In the present study subjects made a series of simple, step-tracking movements about the elbow. A total of eight movement amplitudes were examined, ranging from 5 to 50 deg of arc. In contrast to previous studies, Agl burst duration was found to be strongly dependent on movement amplitude.

In Fig 4 are shown the distribution of pooled Agl durations associated with fast movements made at different amplitudes. A unimodal distribution of burst duration was observed for the smallest (5 deg) and largest (50 deg) amplitudes. Mean (\pm S.D.) burst duration was 71 ± 13 ms for 5 deg movements and 139 ± 23 ms for 50 deg movements. As movement amplitude increased there was a step-like shift from short (60-100 ms) to long (120-160 ms) duration bursts. At intermediate amplitudes (e.g. 30 deg) burst

Figure 4

Distribution of initial agonist burst (Agl) duration associated with fast flexion movements about the elbow.

Each histogram represents the number of movements (ordinate) in which Agl burst duration ranged from 0 to 240 ms (abscissa). Bars are plotted in bin widths of 20 ms. For each movement amplitude (5 - 50 deg) n represents the total number of movements analyzed. Data shown for 5 deg movements were obtained from five subjects; all other histograms were constructed from data obtained from eight subjects.

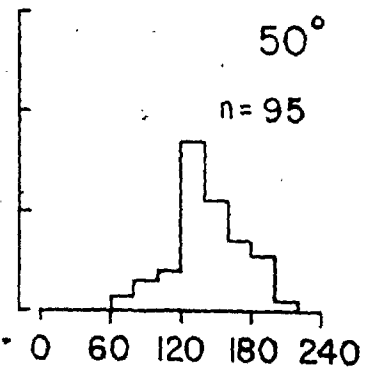
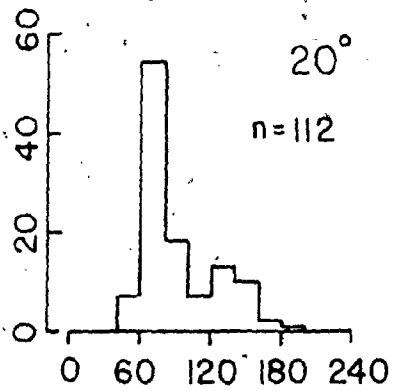
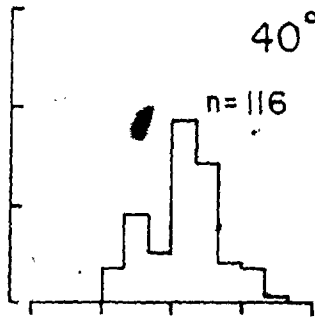
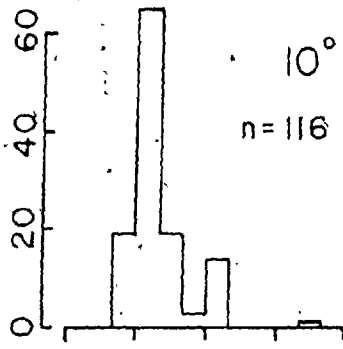
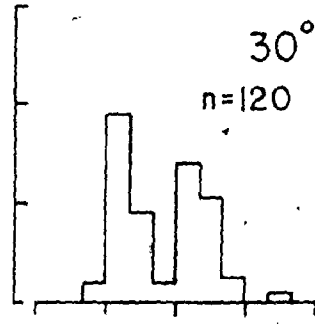
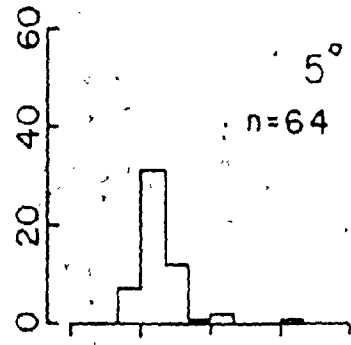

duration was bimodally distributed. Movements were initiated by either a short (60-100 ms) or long (120-160 ms) duration burst. At any given movement amplitude less than 8 per cent of the movements examined had burst durations ranging from 100-120 ms.

Slow movements exhibited a similar distribution of burst duration at different movement amplitudes. This is shown in Fig 5 where mean burst duration was 62 ± 11 ms for 5 deg movements and 155 ± 42 ms for 50 deg movements. At intermediate amplitudes (e.g. 30 deg) both short (60 - 100 ms) and long (120 - 160 ms) duration bursts occurred.

In order to compare mean burst durations within and across subjects, duration ranges were established using the mean \pm 2 S.D. duration value obtained from pooled data for 10 and 50 deg movements. Ten rather than five deg movements were used to determine short duration ranges simply because of the larger sample size. Using these criteria Agl bursts were considered to be of short duration if they fell between 42 and 94 ms for fast movements and between 39 and 91 ms for slow movements. Agl bursts were considered to be long duration if they fell between 95 and 185 ms for fast movements and between 95 and 237 ms for slow movements.

Changes in the proportion of short versus long duration Agl bursts with movement amplitude are shown for both fast and slow movements in Fig 6. In both cases, nearly 90 per cent of small amplitude movements (5 deg) were initiated by

Figure 5

Distribution of initial agonist burst (Agl) duration associated with slow flexion movements about the elbow. Histograms are plotted as in Fig.4. Data shown for 5 deg movements were obtained from four subjects; all other histograms were constructed from data obtained from seven subjects.

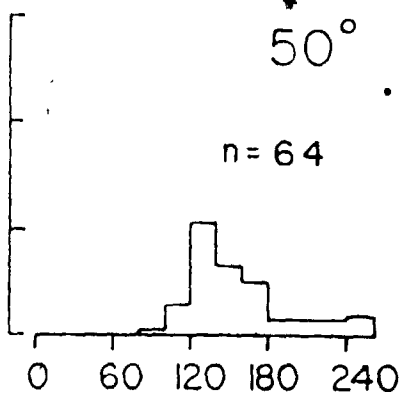
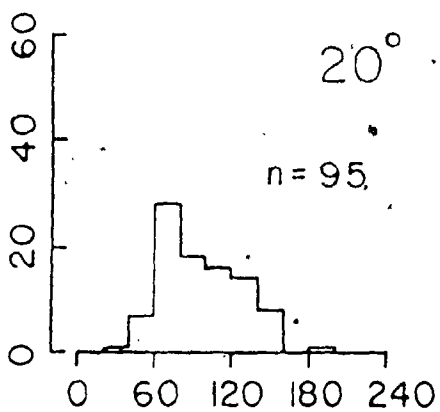
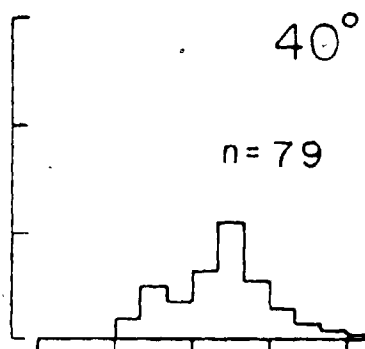
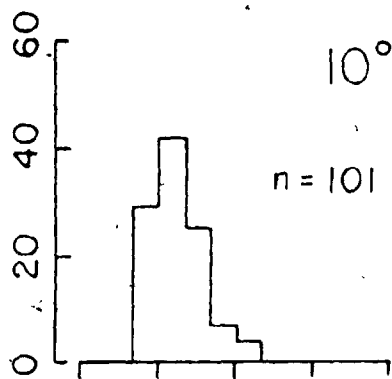
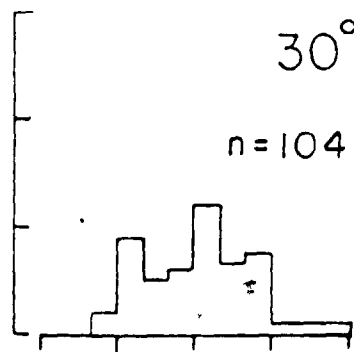
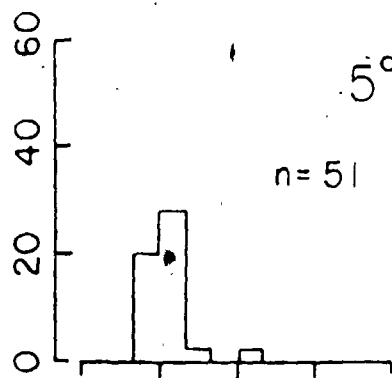
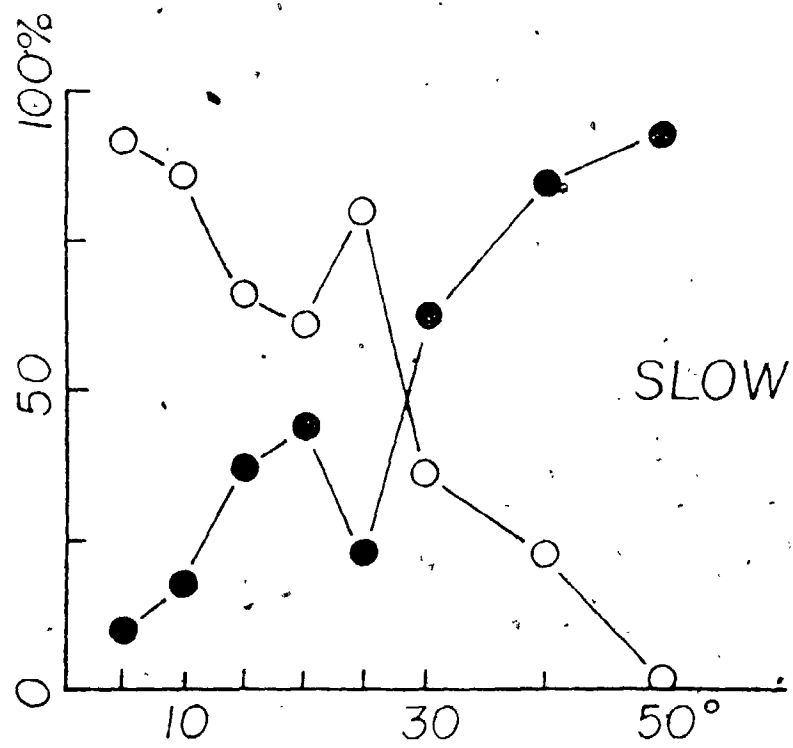
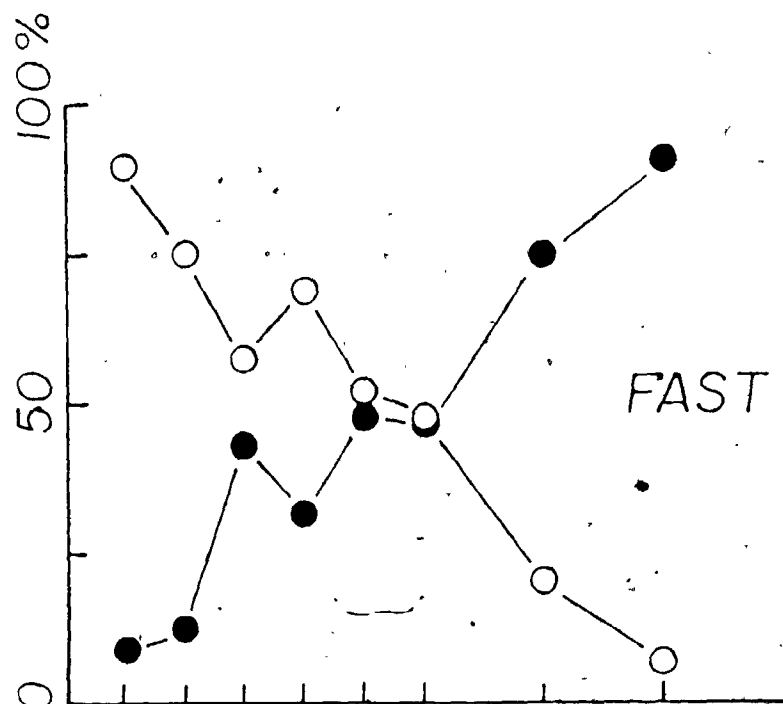

Figure 6

Changes in the proportion of short versus long duration initial agonist bursts (Agl) with movement amplitude. The number of movements in which Agl duration was classified as being either short (open circles) or long (filled circles) is expressed as a percentage of the total number of duration measurements (ordinate) made at each movement amplitude (abscissa). Data obtained from fast movements are shown in the upper graph; data from slow movements are shown in the bottom graph. Short duration ranges: (42 - 94 ms, fast movements; 39 - 91 ms, slow movements); long duration ranges: (95 - 185 ms, fast movements; 95 - 237 ms, slow movements).



short duration bursts (open circles) while at the largest movement amplitude (50 deg), less than 6 per cent of the movements were initiated by short duration bursts. In contrast, the number of long duration bursts (filled circles) increased from 9 per cent at small amplitudes (5 deg) to over 90 per cent at large amplitudes (50 deg). At intermediate movement amplitudes the number of short duration bursts was approximately equal to the number of long duration bursts, reflecting, at least for fast movements, the distinctly bimodal distribution of burst durations seen in Fig 4 (30 deg).

Thus for both fast and slow movements, the duration of the initial agonist burst increased with movement amplitude. The change in burst duration was not graded, but instead occurred as an apparent doubling of burst duration at intermediate movement amplitudes.

Both short and long duration bursts exhibited little variability in duration across movement amplitudes. This is shown for two subjects, in Fig. 7A,B and for all subjects in Tables 1 and 2. In each histogram in Fig. 7, open bars represent mean duration of short duration bursts; stippled bars represent mean duration of long duration bursts. At smaller movement amplitudes where there was a greater proportion of short (open bars) versus long duration (stippled bars) bursts, burst durations showed little variability. This is particularly evident in Fig. 7A where

Figure 7

Mean initial agonist burst (Agl) durations associated with fast and slow movements made at different movement amplitudes. Results are shown for two subjects (A,B). In each histogram bars represent data obtained from movements of increasing amplitudes (5,10,15,20,25,30,40 and 50 deg). At each amplitude, the duration range which included that larger number of observations (short versus long duration) was used for construction of histograms. Open bars represent short duration Agl bursts; stippled bars, long duration Agl bursts. Each bar is the average of six to fifteen movements. Error bars represent 1 S.E. of the mean. See Tables 1 and 2 for mean duration values for subjects JJ and BA. Short duration ranges: (42 - 94 ms, fast movements; 39 - 91 ms, slow movements); long duration ranges: (95 - 185 ms, fast movements; 95 - 237 ms, slow movements).

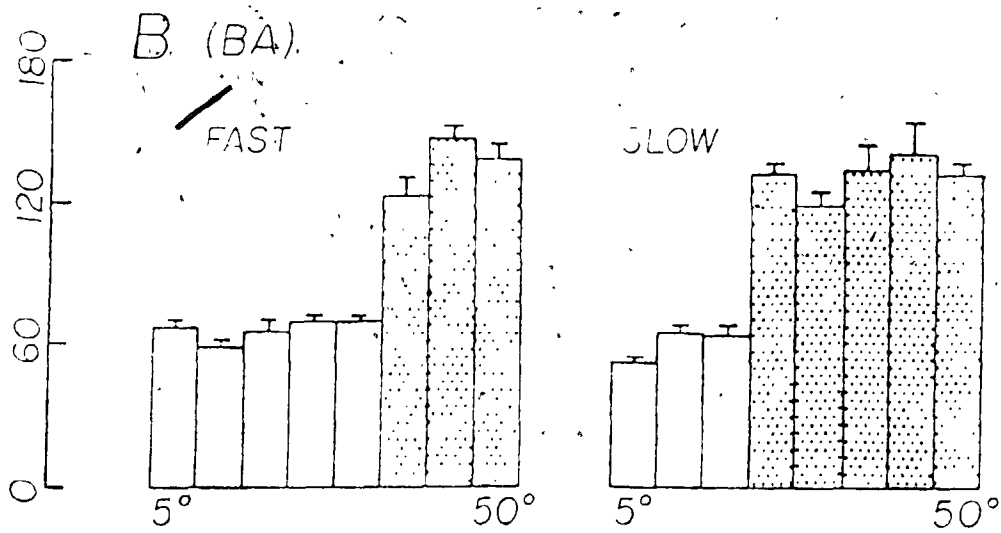
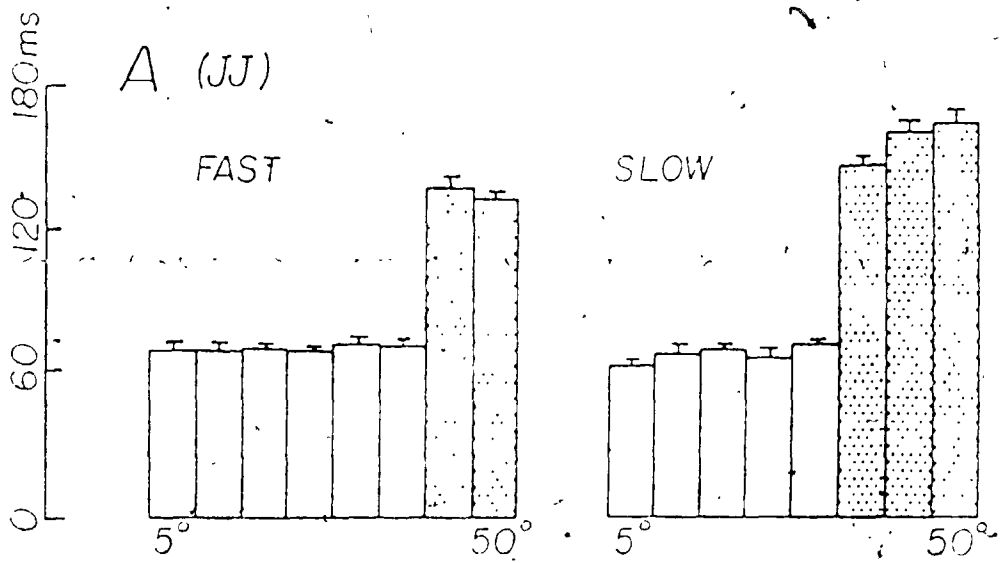

TABLE 1
Duration of the initial agonist burst (agl) associated with fast movements

	Movement Amplitude (deg)									
	5	10	15	20	25	30	40	50		
JJ	70.0 ± 2.5 ^a (15)	70.0 ± 3.2 (15)	71.4 ± 1.8 (14)	70.6 ± 1.4 (14)	72.7 ± 2.3 (15)	72.2 ± 3.3 (9)	138.0 ± 5.6 (12)	134.3 ± 3.1 (15)		
ND	—	75.0 ± 1.7 (7)	—	126.7 ± 3.7 (6)	—	137.3 ± 4.2 (13)	146.9 ± 6.7 (8)	165.0 ± 5.1 (12)		
EA	67.7 ± 3.5 (11)	58.6 ± 3.5 (11)	65.0 ± 4.6 (7)	69.5 ± 1.4 (11)	70.0 ± 1.4 (10)	122.8 ± 6.9 (7)	147.0 ± 5.0 (10)	138.7 ± 5.9 (12)		
RI	75.7 ± 2.2 (7)	76.8 ± 2.4 (11)	88.1 ± 3.8 (7)	130.0 ± 5.8 (5)	130.0 ± 5.8 (11)	145.0 ± 4.4 (10)	138.5 ± 3.6 (10)	151.8 ± 4.8 (11)		
RS	68.0 ± 3.2 (10)	64.6 ± 2.2 (12)	—	143.8 ± 8.2 (8)	82.5 ± 3.4 (8)	77.7 ± 2.9 (11)	137.7 ± 5.9 (11)	155.0 ± 6.0 (9)		
DF	—	60.0 ± 3.1 (5)	130.6 ± 7.8 (8)	138.1 ± 4.2 (8)	136.2 ± 3.7 (8)	140.0 ± 2.5 (10)	144.5 ± 1.7 (10)	135.6 ± 3.8 (8)		
RM	—	56.0 ± 2.8 (10)	—	60.0 ± 2.8 (10)	—	77.5 ± 4.2 (6)	118.3 ± 4.4 (6)	109.0 ± 8.9 (8)		
DC	64.3 ± 3.3 (15)	73.7 ± 4.0 (15)	110.5 ± 2.6 (9)	78.9 ± 2.8 (11)	106.1 ± 1.0 (9)	73.6 ± 3.8 (14)	116.7 ± 3.8 (9)	123.0 ± 3.3 (14)		

^amean ± SE in ms. At each amplitude, the duration range which included the larger number of observations (short durations range (42-94 ms) versus long duration range (95-185 ms)).
^bnumber of analyzed movements (n)

TABLE 2
Duration of the initial agonist burst (Agl) associated with slow movements

Subj	Movement Amplitude (deg)									
	5	10	15	20	25	30	40	50		
JJ	64.0±2.4 ^a (15) ^b	69.2±4.1 (12)	70.6±2.2 (9)	67.1±3.7 (10)	72.5±1.3 (12)	148.3±4.1 (9)	162.2±4.6 (9)	165.7±5.8 ^a (7)		
BA	51.7±2.2 (12)	64.4±3.4 (8)	63.3±4.9 (9)	131.4±4.8 (7)	117.8±6.3 (7)	133.1±8.6 (8)	140.0±13.7 (5)	151.6±4.6 (11)		
RS	---	75.0±3.7 (7)	---	---	79.2±2.6 (8)	154.5±6.5 (10)	135.0±10.9 (5)	147.8±5.0 (9)		
DF	60.7±4.9 (7)	59.2±6.1 (6)	68.3±2.3 (6)	73.3±6.1 (6)	61.0±7.8 (5)	137.5±8.7 (6)	141.0±13.8 (5)	155.2±7.6 (7)		
KM	---	53.1±3.7 (8)	---	50.8±3.6 (6)	---	59.2±4.1 (6)	141.1±11.3 (9)	125.5±3.9 (9)		
CB	---	74.3±2.2 (15)	---	82.7±2.5 (13)	---	163.5±11.2 (8)	163.2±6.3 (17)	---		
DC	59.6±3.9 (12)	67.5±3.7 (14)	75.6±3.6 (8)	109.6±2.5 (13)	72.0±1.8 (14)	116.4±3.1 (11)	135.0±7.7 (12)	138.0±8.7 (9)		

^amean ± S.E. in ms. At each amplitude, the duration range which included the larger number of observations (short duration range (39 - 91 ms) versus long duration range (95 - 237 ms) was used to determine mean values.

^bnumber of analyzed movements (n).

mean burst durations associated with 5 to 30 deg fast movements varied by only 3 ms (Table 1, subject JJ). Similar findings were observed for large amplitude movements with long duration bursts (stippled bars), although mean burst duration was somewhat more variable than that observed for short duration bursts associated with small amplitude movements (cf. Tables 1 and 2).

In general, mean Agl durations exhibited little variability across all subjects examined. This is shown in Fig 8 and Table 3 for both short (open bars-A,C) and long (stippled bars-B,D) duration bursts. Short duration bursts varied from 60 to 80 ms for fast movements and from 54 to 78 ms for slow movements. Long duration bursts varied from 114 to 146 ms for fast movements and from 122 to 157 ms for slow movements.

B. Fine structure of Agl

A detailed analysis of individual EMG records revealed that the doubling of burst duration at larger movement amplitudes was due to the presence of a second peak of agonist activity immediately following Agl. In Fig 9 are shown typical records of agonist EMG activity associated with slow flexion movements. For 10 deg movements (Fig 9-A) Agl consisted of a single peak of activity with a duration of approximately 60 ms. At 30

Figure 8

Subject variability in mean initial agonist burst (Agl) durations. Open bars represent short duration Agl bursts; filled bars, long duration Agl bursts. In each set of histograms (fast - A,B; slow - C, D,) each open bar and the corresponding stippled bar represent data obtained from a different subject. For each subject data have been pooled from all movement amplitudes. Error bars represent 1 S.E. of the mean. Short duration ranges: (42 - 94 ms, fast movements; 39 - 91 ms, slow movements); long duration ranges: (95 - 185 ms, fast movements; 95 - 237 ms, slow movements).

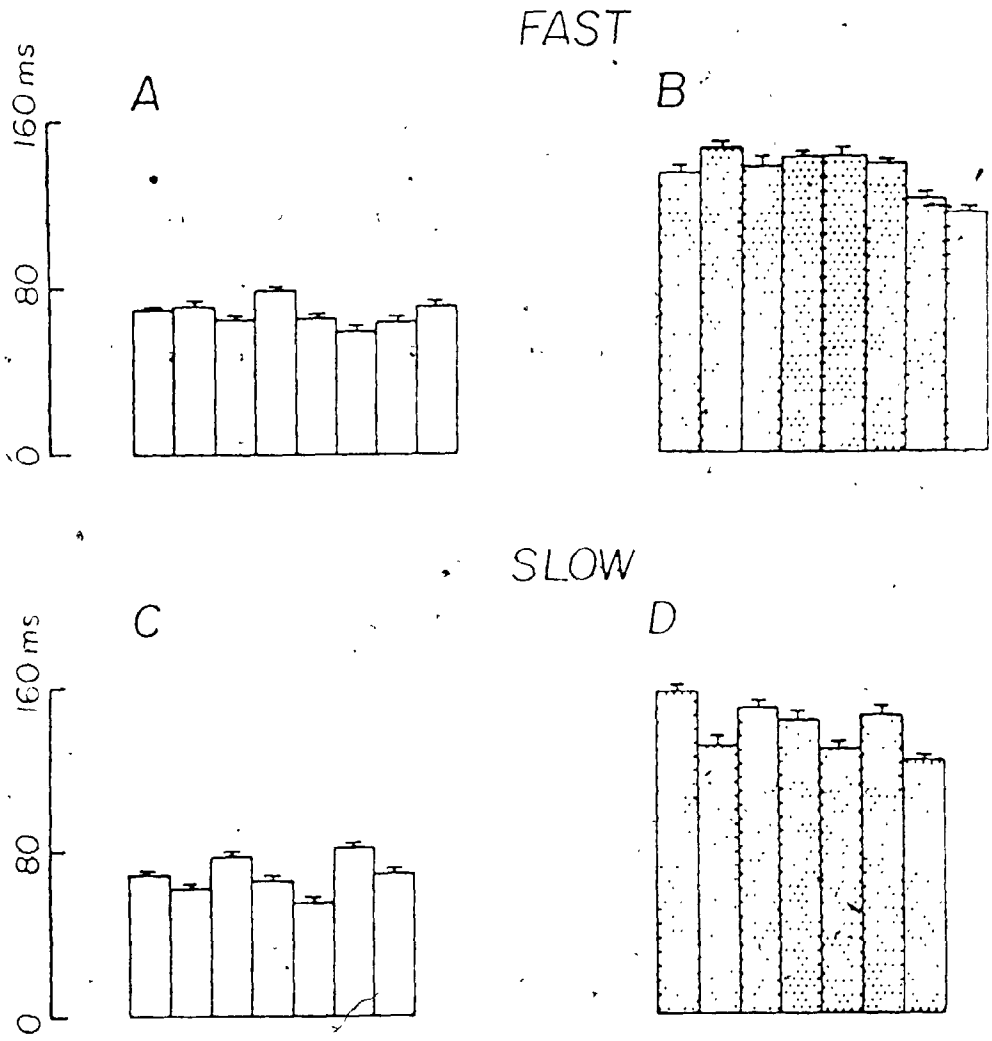

Mean short and long duration initial agonist bursts (Agl) across subjects

<u>Fast Movements</u>		
<u>Subj</u>	<u>Short Duration</u>	<u>Long Duration</u>
JJ	71.1 ± 1.0 ^a (82) ^b	135.9 ± 3.2 (37)
WD	71.8 ± 2.9 (11)	146.5 ± 3.2 (40)
BA	66.0 ± 1.6 (57)	137.8 ± 3.9 (29)
RI	80.0 ± 1.9 (26)	141.3 ± 2.6 (42)
RS	67.5 ± 1.7 (22)	141.6 ± 3.6 (34)
DF	60.0 ± 3.0 (5)	138.3 ± 1.5 (52)
KM	67.2 ± 2.5 (34)	120.8 ± 2.5 (12)
DC	73.2 ± 1.6 (67)	114.2 ± 1.8 (46)

<u>Slow Movements</u>		
<u>Subj</u>	<u>Short Duration</u>	<u>Long Duration</u>
JJ	68.2 ± 1.3 (57)	157.0 ± 2.8 (27)
BA	61.4 ± 1.6 (50)	130.2 ± 3.9 (31)
RS	77.4 ± 2.1 (15)	148.7 ± 3.8 (23)
DF	65.4 ± 2.5 (33)	140.0 ± 5.2 (28)
KM	54.2 ± 2.1 (20)	128.5 ± 3.6 (17)
CB	78.0 ± 1.4 (32)	145.8 ± 4.0 (30)
DC	68.3 ± 1.8 (50)	122.5 ± 2.8 (50)

^amean ± S.E. in ms. Short duration ranges were 42-94 ms for fast movements and 39-91 ms for slow movements while long duration ranges were 95-185 ms for fast movements and 95-237 ms for slow movements.

^bnumber of analyzed movements (n) pooled from all movement amplitudes.

and 50 deg, however, a second period of EMG activity occurred (Fig. 9B,C). This second period started just after movement onset and was complete well before the movement reached peak velocity. This second period of agonist activity is thus not equivalent to the second agonist burst of the triphasic EMG pattern but represents a second component of the initial agonist burst. In these particular movements the total duration of the two components of activity was approximately 120 ms, twice the duration of Agl seen in 10 deg movements.

In this subject movements made at 30 deg were associated with either a single or double component Agl burst. This alternation between short and long duration Agl bursts at 30 deg is shown in Fig 9D where the third and fifth records show initial agonist bursts having only one component while the other records show initial agonist bursts having two components. It can be seen that in those records having two components, the second component starts just after movement onset (arrows) and ends (second dashed line) before peak velocity is reached. In this particular subject, the amplitude at which the second component first appeared was 30 deg. For other subjects, the amplitude at which the second peak started to appear ranged from 20 to 40 deg. This corresponds to the distribution of burst durations seen in Figs. 4 and 5 (20, 40 deg).

Intramuscular recording of multiple motor unit activity

Figure 9

Effects of movement amplitude on duration of the initial agonist burst (Agl). Individual biceps EMGs from slow flexion movements of three different amplitudes (10, 30, 50°-deg) are shown in each set of traces (A-C). EMG data from three subjects are shown in each set. The velocity record, corresponding to the first EMG record in each set, is shown to indicate the onset of agonist activity relative to movement onset. In D are shown individual EMG records associated with a series of 30 deg movements obtained from one subject. Vertical dashed lines indicate onset and termination of Agl in records in which two peaks of activity are evident. Arrows indicate the time of movement onset and approximate the onset of the second burst of agonist activity. Vertical calibration represents 100 deg/s; horizontal calibration, 100 ms.

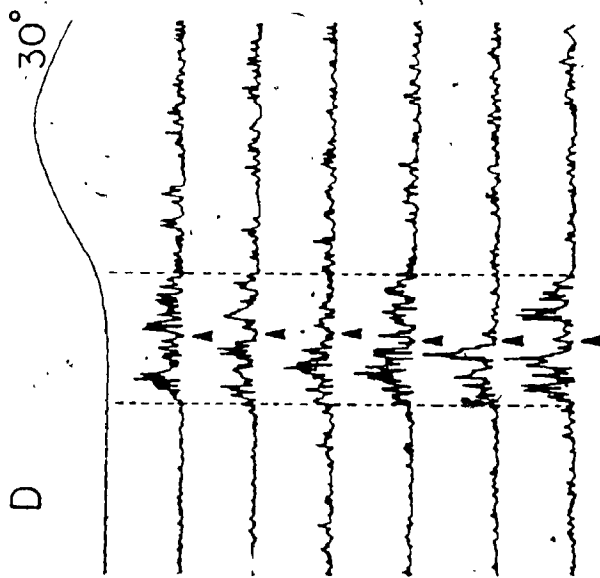
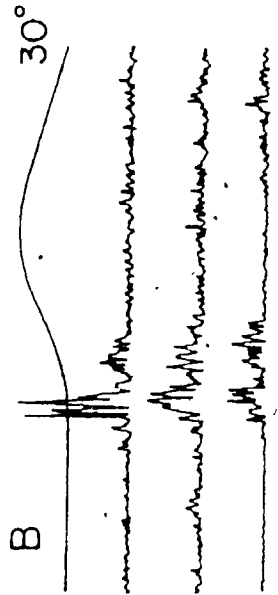
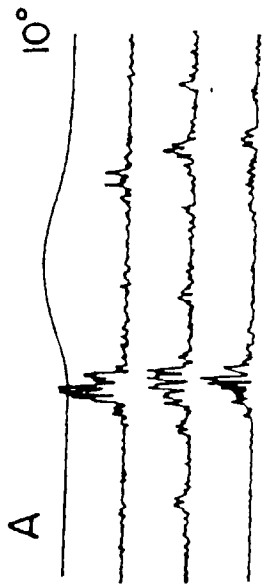

during elbow flexion movements confirmed that both components seen in surface EMG records originated from the same muscle and not, for instance, from different heads of biceps brachii. Records of multi-unit activity associated with 40 deg movements are shown in Fig 10. In each intramuscular record (iBiceps) two bursts of multi-unit activity can be recognized, the onset and duration corresponding to the second component of Agl as indicated in the surface EMG record (sBiceps) by the solid bar. Often, when both components were not clearly obvious in the surface record, it was still possible to recognize discrete bursts of multi-unit activity associated with Agl.

In most subjects it was difficult to discern both components in averaged data, particularly when movement onset was used as the synchronization point. Averaging about movement onset of individual records in which both components were clearly obvious (Fig 11B) obscured the biphasic profile of Agl (Fig 11A-av biceps 1). However, synchronization of data around onset of agonist EMG activity (Fig 11A-av biceps 2) yielded average EMG records in which it was possible to distinguish two peaks of activity. Because of the difficulty in preserving the fine structure of Agl during averaging, analysis of individual EMG records was employed throughout all studies.

Although a detailed examination of Agl duration was restricted to flexion movements, a similar change in

Figure 10

Intramuscular biceps (EMG) recordings associated with fast 40 deg flexion movements. The upper three records show position, velocity and surface EMG traces from one movement. The solid bar below the surface EMG record indicates the initial agonist burst (Agl). Individual records of multi-unit activity associated with (Agl) are shown in the bottom four traces. All records are from one subject. Calibration bar represents 200 ms.

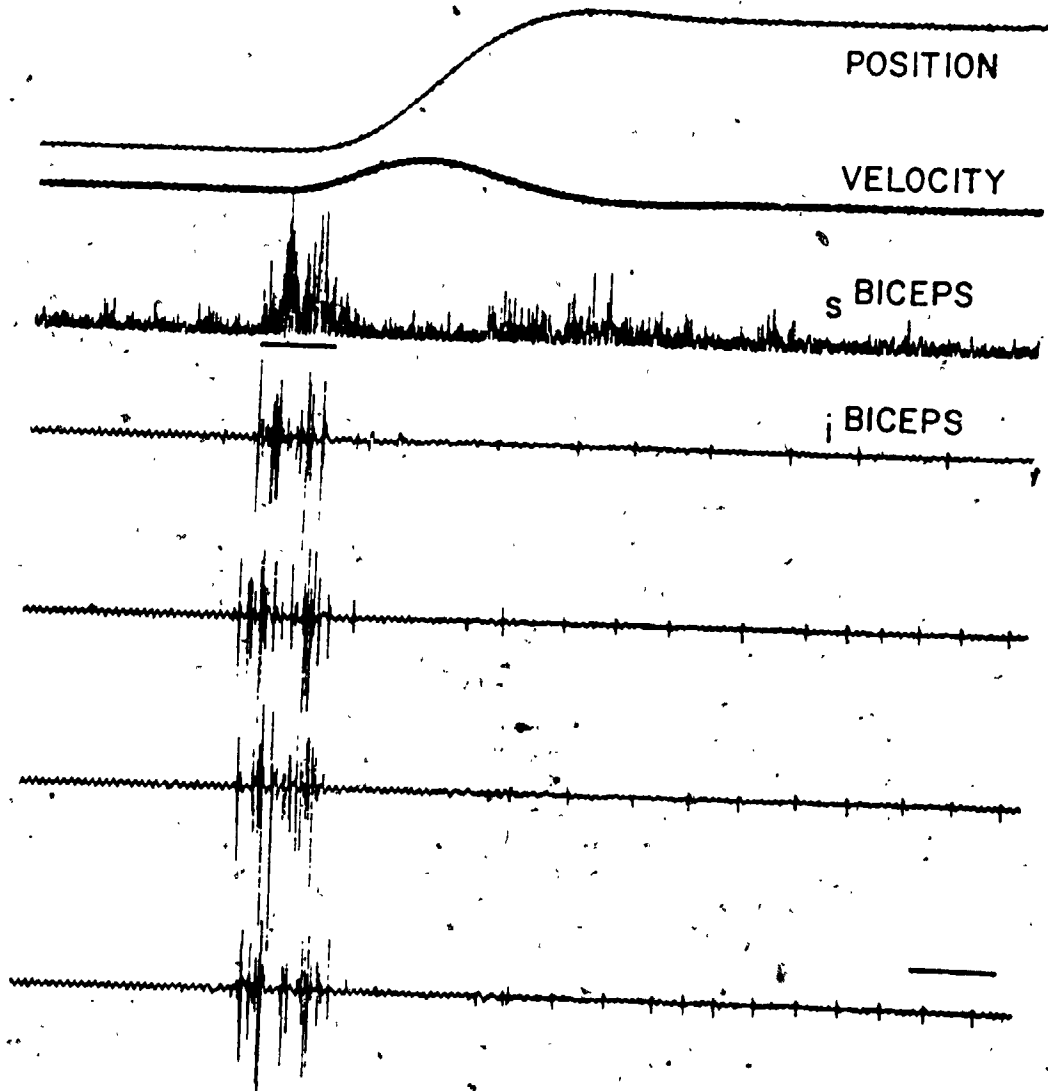
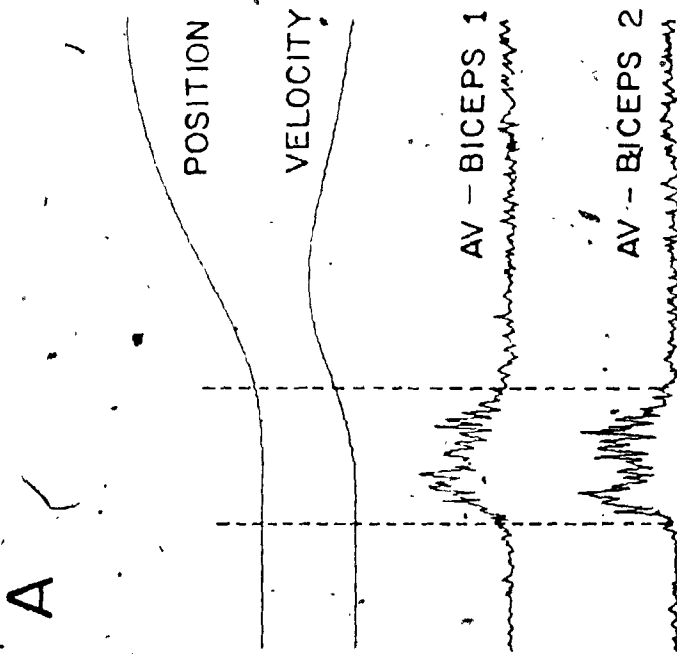
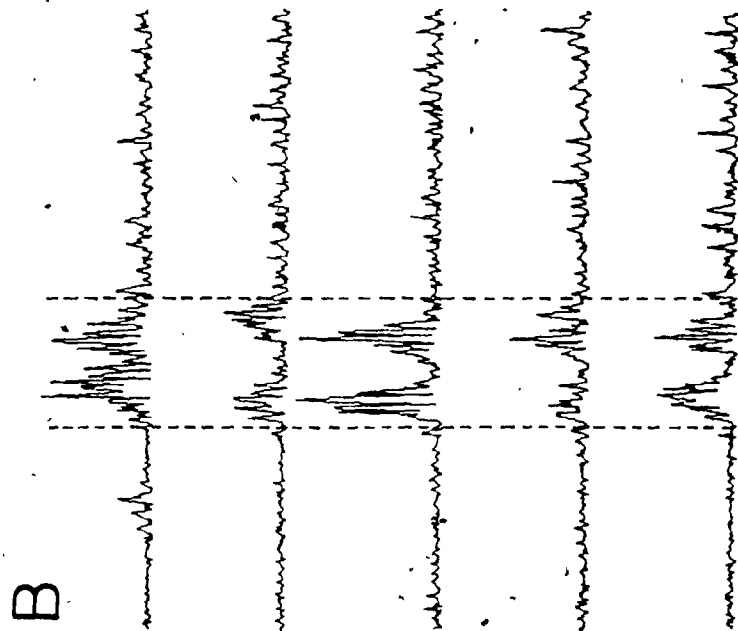

Figure 11

Average agonist EMG activity associated with 50 deg slow movements. In A are shown averaged position, velocity and EMG records obtained from eight flexion movements about the elbow. The upper EMG record (AV-BICEPS 1) was averaged around the onset of movement; the lower EMG record (AV-BICEPS 2) was averaged around the onset of biceps activity. Onset and termination of the initial agonist burst (Ag1) are indicated by the dashed lines. Individual agonist EMG records contributing to averaged data are shown in B. Two peaks of activity are evident during the period of Ag1 as indicated by the dashed lines. Horizontal calibration represents 200 ms. Peak velocity in A was 125 deg/s.



burst duration with movement amplitude was also observed in extension movements. Typical results obtained from the lateral head of triceps brachii during fast extension movements are shown in Fig. 12. Small amplitude (A - 10 deg) movements were associated with initial agonist bursts having only one component while large amplitude (B - 50 deg) were associated with initial agonist bursts having two components. The presence of this second component resulted in a doubling of burst duration from approximately 75 ms in A to approximately 140 ms in B.

C. Amplitude - dependent changes in Agl component magnitude

Earlier studies have shown that Agl magnitude is linearly dependent on movement amplitude (Hallett and Marsden, 1979; Brown and Cooke, 1981a). To determine if this resulted from changes in one or both components, the magnitudes of both components comprising Agl were determined by digital integration. In cases where the second component was not present (e.g. small amplitude movements), EMG activity corresponding in time to the second component was determined. In these cases, EMG activity was integrated over an arbitrary duration of 70 ms starting from the end of the first component (based on mean duration of Agl associated with small amplitude fast movements). In Fig. 13 are

Figure 12

Initial agonist burst (Agl) associated with extension movements about the elbow. Typical triceps EMG activity associated with a fast 10 deg movement is shown in A; triceps activity associated with a fast 50 deg movement are shown in B. In both records onset of Agl is indicated by the first vertical dashed line. The second vertical line indicates the termination of Agl in B. Open arrows indicate onset of movement, filled arrows, time of peak velocity. Horizontal calibration bar represents 100 ms.

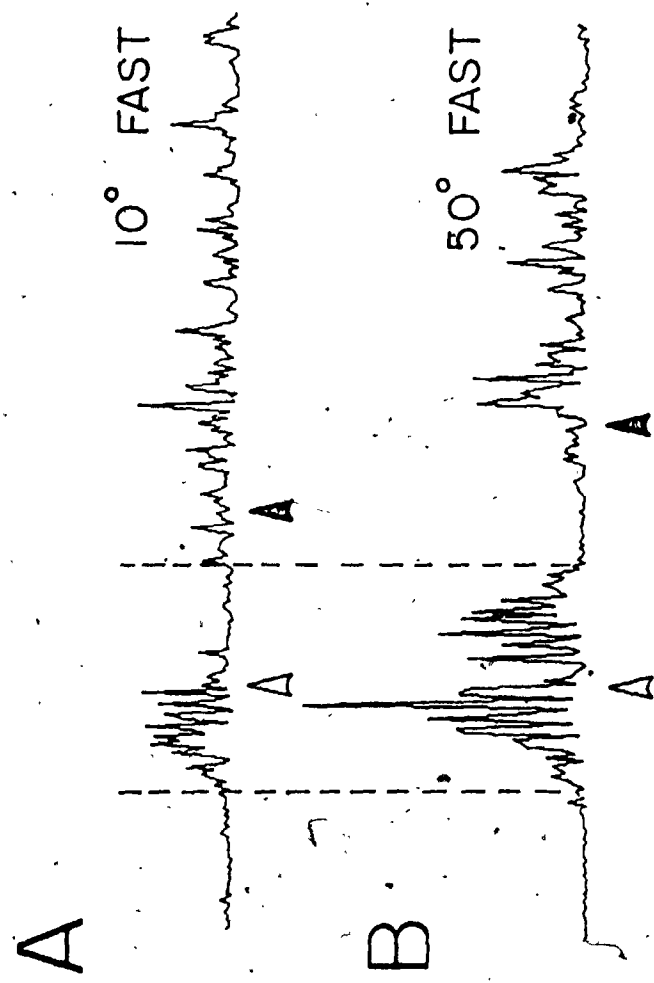

shown averaged magnitudes of the first (circles) and second (squares) components associated with fast movements made at different movement amplitudes. Data obtained from slow movements are shown in Fig. 14. In both cases, each subject (A-D) showed an increase in component magnitude with movement amplitude. At small movement amplitudes where only the first component was present, the magnitude of EMG activity corresponding to the second component remained relatively constant as expected. This is clearly shown for fast movements in Fig. 13B (5-20 deg), C (10-20 deg) and D (5-25 deg). This was also true for slow movements where the second component showed little change in magnitude at small movement amplitudes (Fig. 14B and D (5-25 deg) and C (10-30)). For movement amplitudes where both components were present, changes in component magnitude occurred in parallel. This is particularly evident in Fig 13B and C for 20-50 deg movements and in Fig. 14B and D for 30-50 deg movements.

D. Changes in Agl duration in a deafferented patient

To determine if modulation of Agl duration depended on afferent feedback, movements made by a functionally deafferented patient were examined. Typical records of movement-related agonist EMG activity in this patient are shown in

Figure 13

Effects of movement amplitude on magnitude of the initial agonist burst (Agl) associated with fast movements.

Data are shown for four subjects (A-D). Each data point is the average of six to fifteen movements. Magnitudes of the first (circles) and second (squares) component are expressed as a percentage increase over baseline EMG levels. Duration of both components for purposes of integration were determined by visual inspection. In small amplitude movements where only the first component was present, EMG activity corresponding in time to the second component was integrated over an arbitrary duration of 70 ms. Vertical axis: percentage change in component magnitude, horizontal axis: movement amplitude in deg.

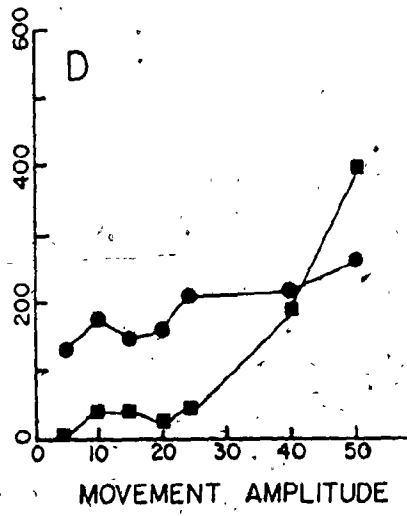
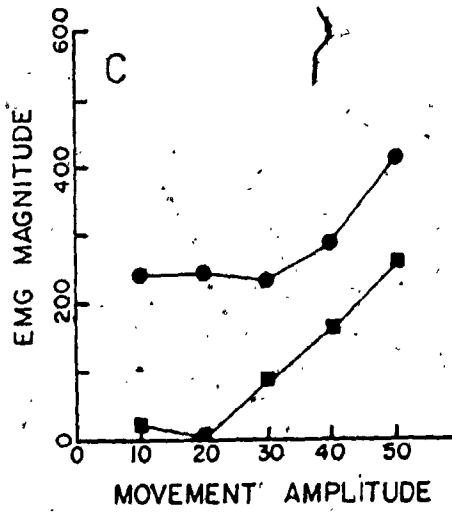
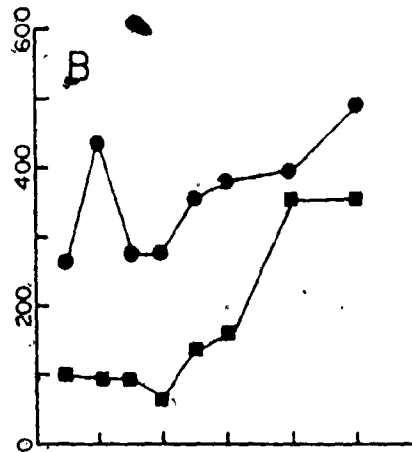
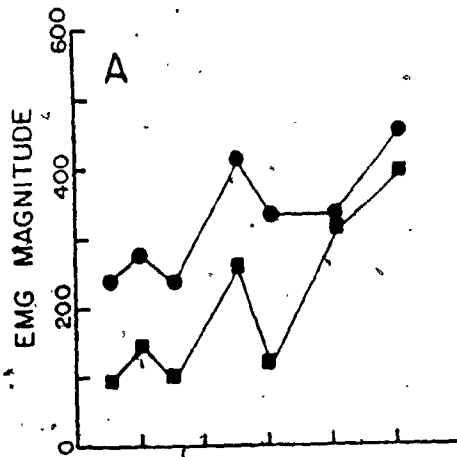

Figure 14

Effects of movement amplitude on magnitude of the initial agonist burst (Agl) associated with slow movements.

Data are shown for four subjects (A-D). Each data point is the average of six to fifteen movements. Magnitudes of the first (circles) and second (squares) component are expressed as a percentage increase over baseline EMG levels. Duration of both components for purposes of integration were determined by visual inspection. In small amplitude movements where only the first component was present, EMG activity corresponding in time to the second component was integrated over an arbitrary duration of 70 ms. Vertical axis: percentage change in component magnitude, horizontal axis: movement amplitude in deg.

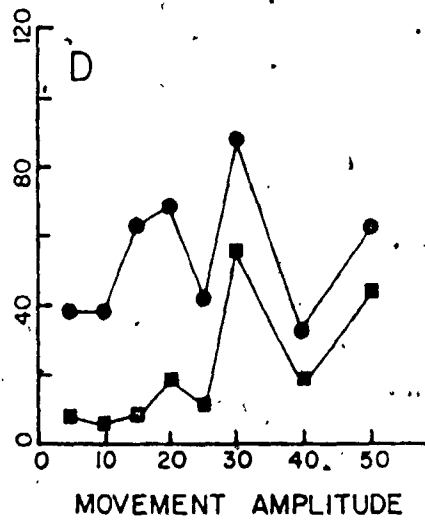
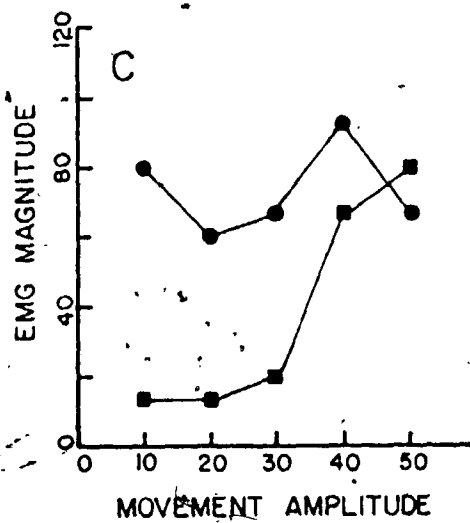
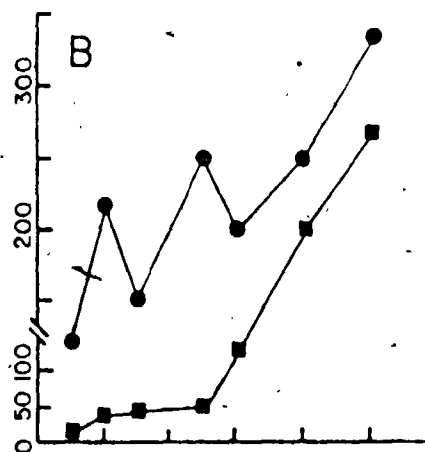
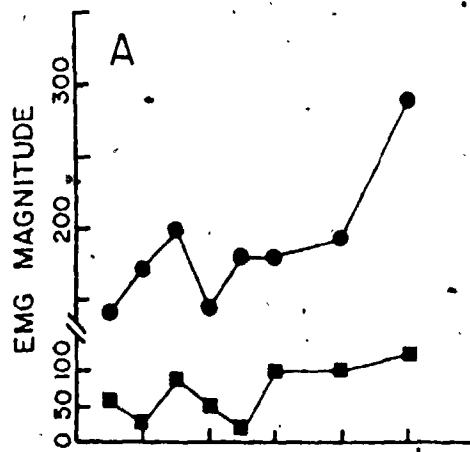

Fig. 15. At each movement amplitude (A-C) movements were initiated by a burst of activity in the agonist (biceps) muscle. As described for Ag1 in normal subjects, this burst of agonist activity started approximately 40 ms before movement onset and ended before the movement reached peak velocity. Movements were often made in two parts as indicated by the inflections on the velocity profiles (Fig 14B,C). Because of this, analysis of phasic EMG activity was restricted to the burst of agonist activity associated with movement initiation.

Visual inspection of individual EMG records clearly showed that Ag1 duration increased with movement amplitude. This is illustrated in the upper panel in Fig. 16 where individual records of EMG activity are shown for three different movement amplitudes. The histogram in the lower panel shows the distribution of Ag1 durations from seventy-six movements made at five different amplitudes. Small amplitude movements (6 and 12 deg) are represented by the first peak in which mean (\pm S.D.) burst duration was 65 ± 16 ms. Intermediate sized movements (36 deg) had a mean burst duration of 136 ± 10 ms (second peak) while large movements (54 and 60 deg) had a mean burst duration of 200 ± 13 ms (third peak).

Initial agonist burst duration was also found to increase with movement amplitude in a smaller sample of movements made without visual guidance. For these move-

Figure 15

Movements of different amplitudes made by a deafferented patient. In A-C are shown records from individual flexion movements of three different movement amplitudes (A - 6 deg; B - 36 deg; C - 60 deg). The traces in each set are of position, velocity, biceps and triceps EMG activity. EMG records were filtered at 20 Hz. Vertical calibration, 50 deg; horizontal calibration, 200 ms.

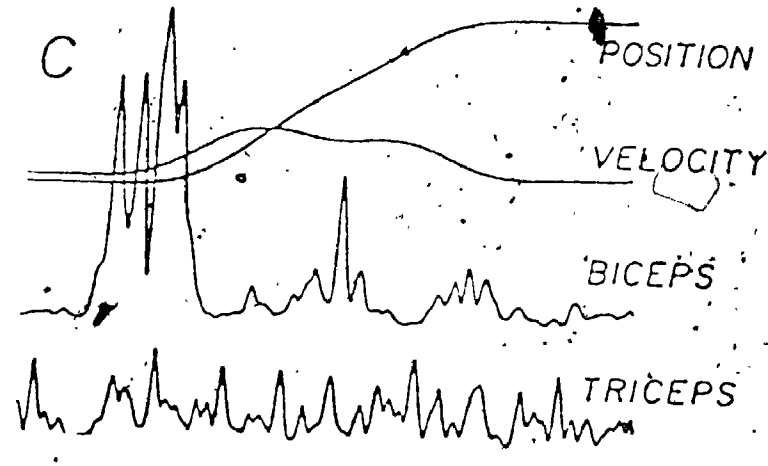
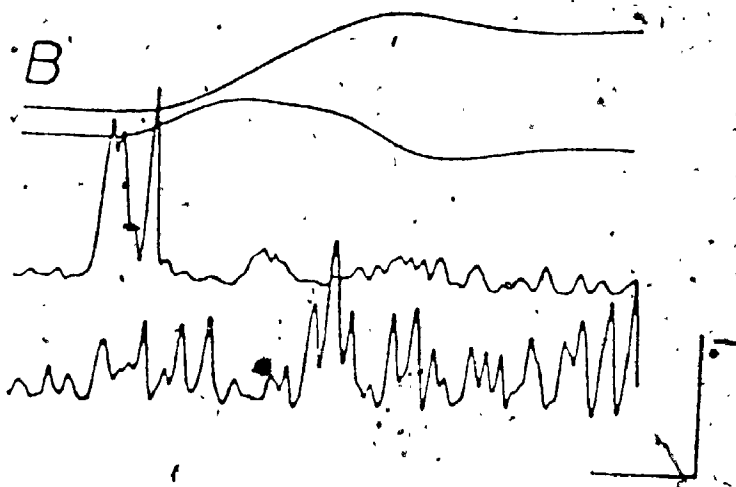
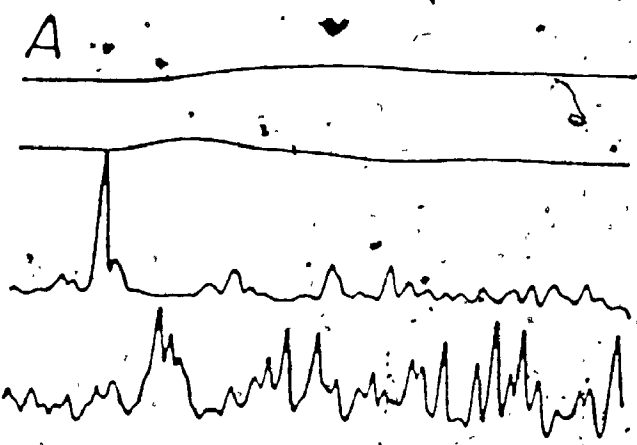

2

MICROCOPY RESOLUTION TEST CHART
NBS 1010a
ANSI and ISO TEST CHART No. 2)

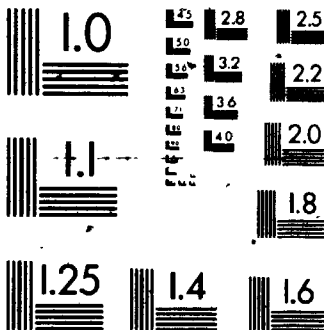
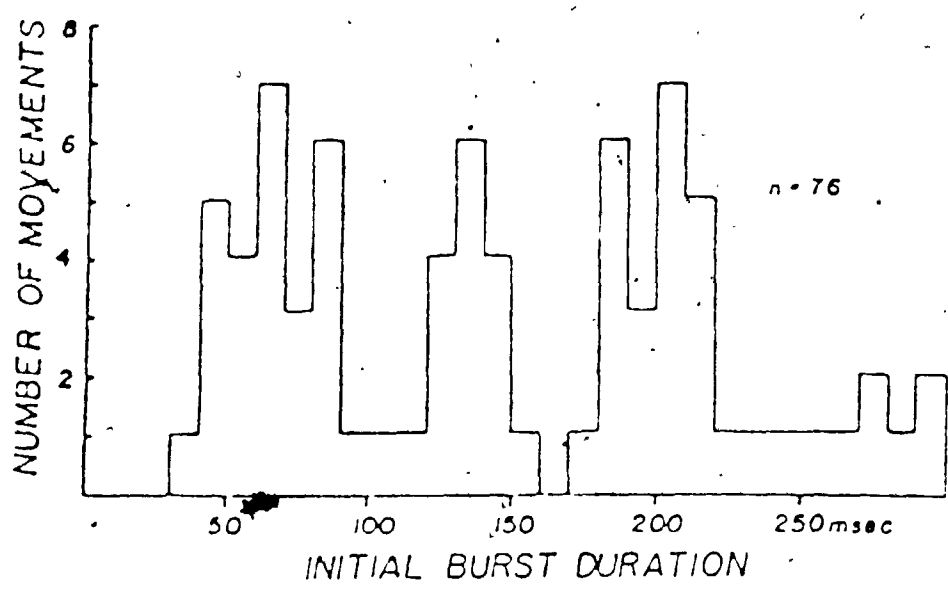
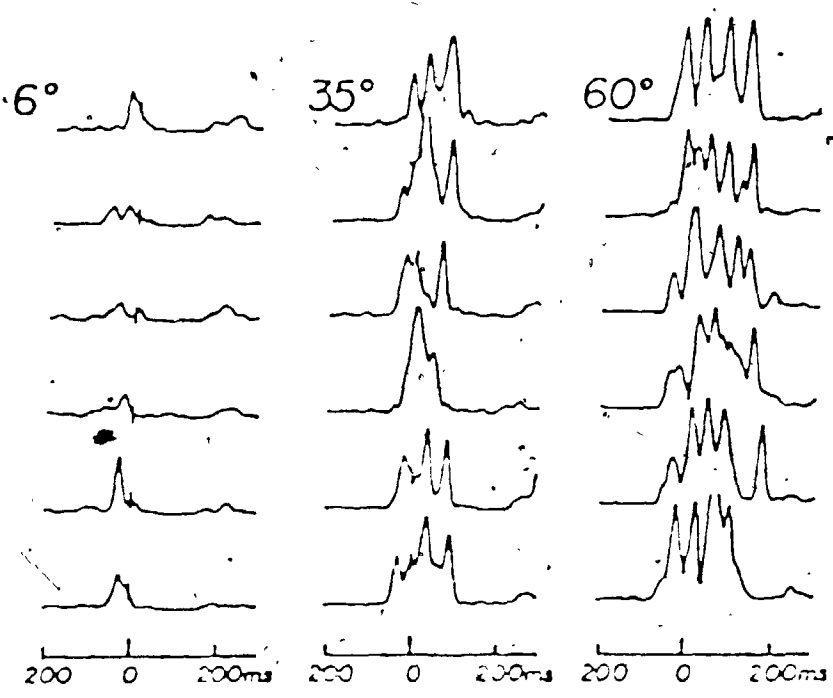

Figure 16

Initial agonist burst (Agl) duration in a deafferented patient. The top sets of traces show initial agonist bursts of individual movements of 3 different amplitudes. Records were filtered at 20 Hz and aligned about the start of movement time (time zero). The histogram shows the distribution of Agl durations in a sample of seventy-six movements made by this patient. Data for the histogram were obtained from movements of five different amplitudes (6, 12, 36, 54 and 60 deg).



ments, the target bar display was turned off before initiation of each flexion movement. Mean durations of Agl were 60 ± 22 ms. for 6.deg movements.

II. Effects of peripheral feedback on the initial agonist burst

The results in the preceding section show that, for large amplitude movements, Agl consists of individual subunits or components of activity. Furthermore, the change in Agl duration resulting from the presence of one or more components does not depend on information arising from the periphery. To determine if these centrally generated components could be altered by peripheral feedback, two sets of experiments were performed. In the first, brief perturbations were applied immediately prior to the onset of movement. In the second, the effects of changes in initial starting position on Agl were examined.

A. Effects of perturbations preceding movement on Agl

1. Changes in Agl magnitude and duration

Brief (50 ms) torque pulses which either loaded or

unloaded the arm were randomly applied prior to movement onset. Typical responses to loading and unloading perturbations applied prior to the onset of slow, 30 deg movements are shown in Fig. 17. In each set of traces are shown arm position, velocity, biceps and triceps EMG activity associated with individual flexion movements. In control, non-perturbed movements (upper set of records in Fig 17A & B), Agl consisted of two components of activity. These components are indicated by the vertical dashed lines. Onset of the first component preceded movement onset by approximately 40 ms while activity corresponding to the second component ended well before peak velocity was reached.

Perturbations opposing the movement consistently resulted in an increase in the magnitude of both components of Agl (Fig 17A - Load). In contrast, perturbations assisting the movement caused a graded increase in the magnitude of the first component and a decrease in the second component (Fig 17B - Unload). These effects were observed in all five subjects examined. Since these movements were relatively slow, phasic antagonist activity in control movements was often absent (Fig 17 - control A,B). Occasionally, large loading perturbations resulted in an increase in antagonist activity. Since these effects were highly variable from trial to trial and from subject to subject, a detailed analysis of antagonist activity was not

Figure 17

Effects of perturbations applied prior to movement onset. Each set of records (top to bottom) shows position, velocity, agonist and antagonist EMG activity during individual, slow movements. Perturbations 50 ms in duration were applied to the arm before movement onset and either opposed (A - Load) or assisted (B - Unload) the forthcoming movement. Perturbation onset is indicated by the downward velocity displacement in the case of loading (A) and the first upward velocity displacement in the case of unloading (B). In both A and B the upper set of records represents typical control movements in which no perturbation occurred. Each set of records was obtained from the same subject. Vertical calibration in A: 17 deg, 150 deg/s and in B: 24 deg, 150 deg/s. Horizontal calibration: 200 ms.

A. CONTROL

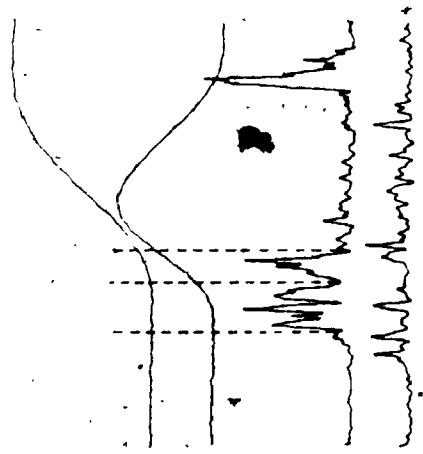

LOAD

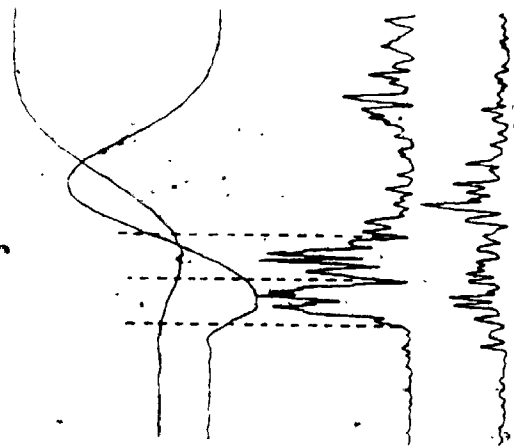

B

CONTROL

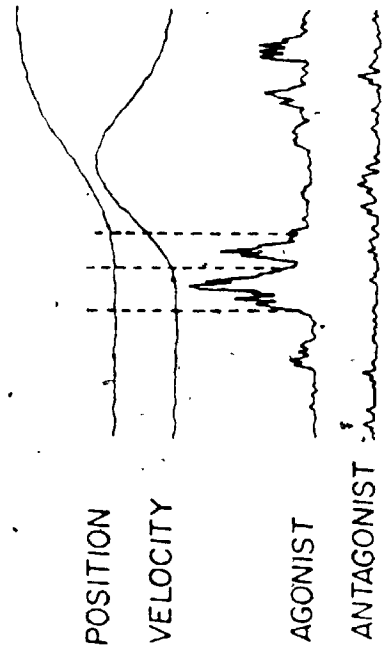

UNLOAD

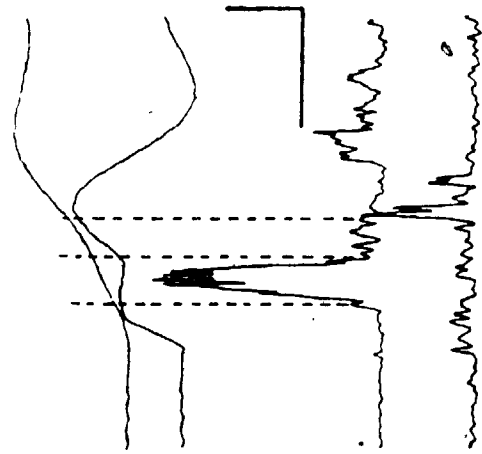

performed in these experiments.

The changes in component magnitude associated with both loading and unloading were graded with the strength of the perturbation. In Fig 18 are shown the effects of different perturbation magnitudes on both components of Ag1. The traces to the left show average records of agonist (biceps) EMG activity associated with slow, flexion movements obtained from one subject. In each set of records (Load, Unload), control, non-perturbed movements are represented by the velocity and uppermost EMG record. With loading, the magnitude of both components increased compared to the control movements. Larger perturbations (5.0 Nm) caused a greater increase than the smaller perturbation (3.0 Nm). In general, the increase in magnitude was more marked for the second component than for the first, particularly at larger perturbation magnitudes. The increase in magnitude of the first component produced by unloading was strongly dependent upon perturbation magnitude, as was the corresponding decrease in magnitude of the second component. In some subjects, especially at large perturbation magnitudes, no phasic activity corresponding to the second component was present (cf. Fig. 17B. Fig. 18 - Unload, 4.0 Nm).

The dependence of both component magnitudes on the size of the perturbation is shown for five subjects in the graphs to the right in Fig. 18. Integrated EMG activity of both components is expressed as a percentage increase or decrease

Figure 18

Dependence of EMG response on perturbation magnitude during slow movements. On the left are shown records of average (n=5) biceps EMG activity from movements with loading and unloading forces applied prior to movement. In each set of records (load and unload) the velocity and the first EMG record represent control movements. The vertical dashed lines indicate the onset and termination of both components of Agl in control movements. The range of perturbation onset times is indicated by the horizontal bar below each perturbed record. Numbers to the left of the EMG records indicate the magnitude of the force perturbation in Nm. The graphs to the right show the change in the magnitude of the first (Agl_a) and the second component (Agl_b) as a function of the peak change in velocity resulting from the applied force. EMG magnitudes, determined as the value of the integrated EMG activity during each component, are plotted as a percentage change over control values. Since the degree of arm displacement caused by a given perturbation magnitude differed across subjects, perturbation magnitudes are expressed in terms of the maximum velocity of arm displacement produced by the perturbation rather than absolute force magnitude. Each data point was derived from the average of six to ten movements. Different symbols represent data from each of five subjects. Vertical calibration: 100 deg/s.

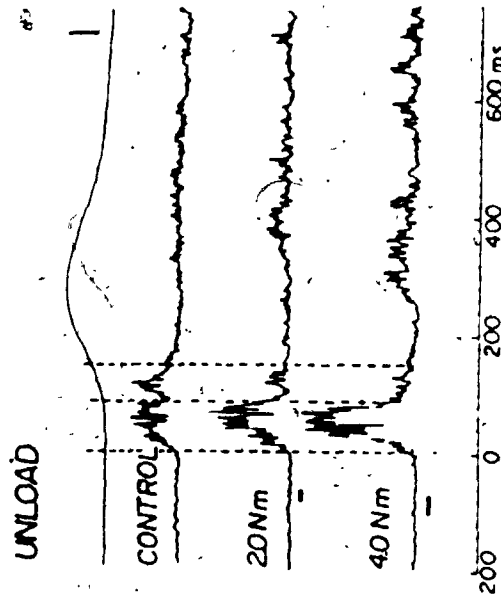
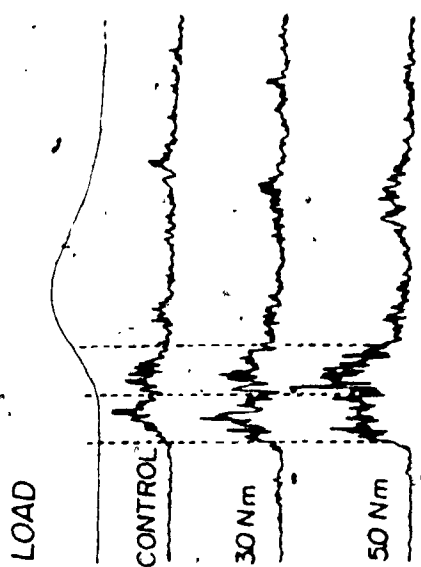
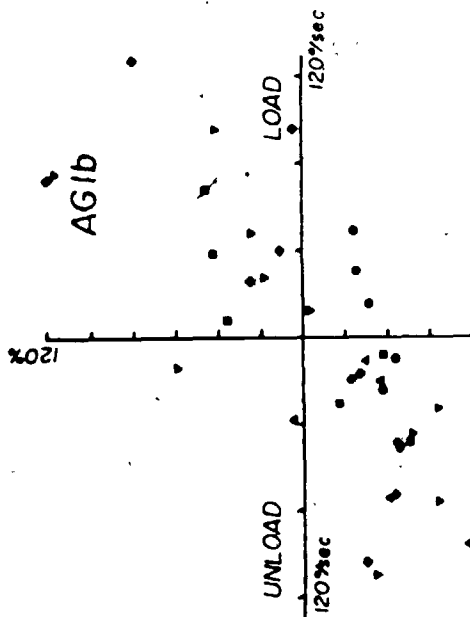
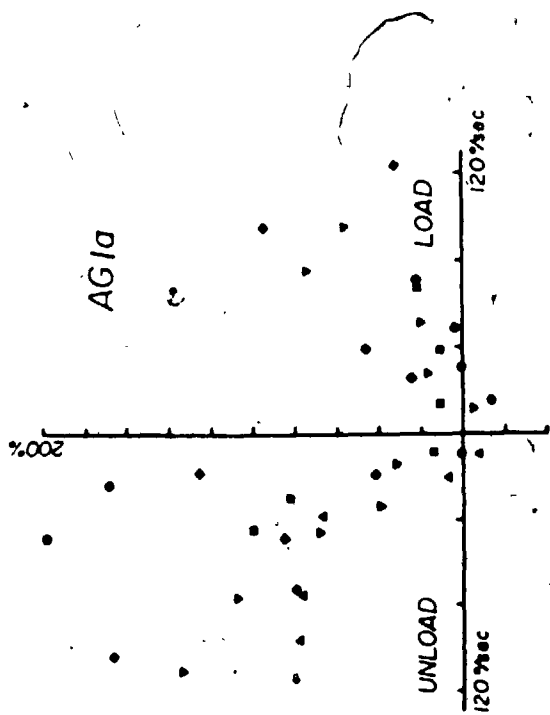

over control, non-perturbed EMG values. Percentage changes in EMG activity are plotted as a function of the maximum velocity resulting from the applied force rather than absolute levels of applied force. This was necessary since a given perturbation magnitude could result in varying degrees of displacement across subjects, presumably because of differences in the level of tonic muscle contraction prior to movement.

Perturbations which loaded biceps produced a graded increase in the magnitude of both the first (Agl_a) and second (Agl_b) components. In contrast, unloading perturbations produced a differential effect on the two components. In all subjects, the magnitude of the first component increased with unloading; this increase being strongly dependent upon perturbation magnitude. Concomitant with the increase in magnitude of the first component, the second component showed a decrease in magnitude which was also graded with perturbation magnitude. In general, the percentage increase in the magnitude of the first component was greater than the percentage decrease of the second component, especially at medium to large force levels.

Similar relationships were found in fast movements (Fig. 19). Perturbations opposing the movement produced an increase in both the first and second components. This increase was not as great as that seen in slow movements and the grading with perturbation magnitude was somewhat more

Figure 19

Dependence of EMG response on perturbation magnitude during fast movements. On the left are shown records of average biceps EMG activity from movements with loading and unloading forces of different magnitudes. In each set of records (load and unload) the velocity and the first EMG record indicate the onset and termination of both components of Ag1. The range of perturbation onset times is indicated by the horizontal bar below each perturbed record. The numbers to the left of the EMG records indicate the magnitude of the force perturbation in Nm. The percentage change in magnitudes of the first component (Ag1a) and second (Ag1b) component as a function of the peak change in velocity resulting from the applied force is shown in the graphs to the right. EMG magnitudes, determined as the value of the integrated EMG activity during each component, are plotted as a percentage change over control values. Since the degree of arm displacement caused by a given perturbation magnitude differed from subject to subject, perturbation magnitudes are expressed in terms of the maximum velocity of arm displacement produced by the perturbation rather than absolute force magnitude. Each data point was derived from the average of six to ten movements. The different symbols represent data from each of five subjects. Vertical calibration: 150 deg/s.

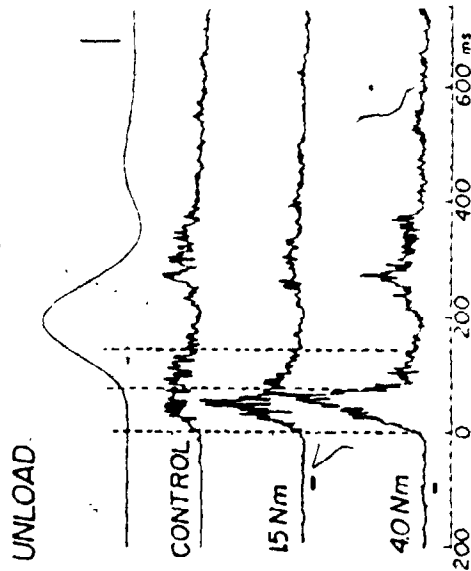
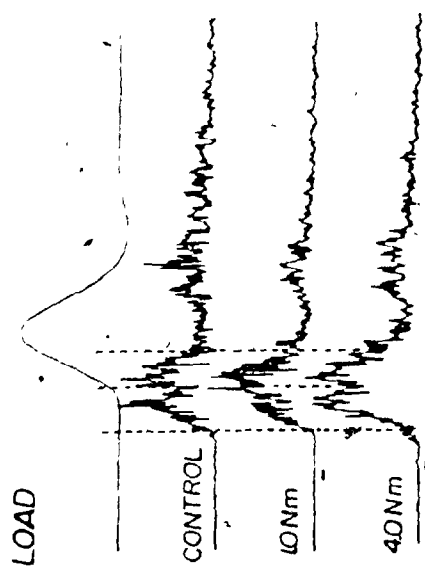
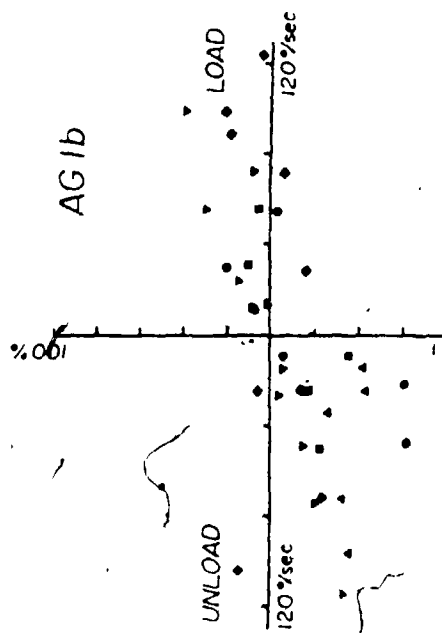
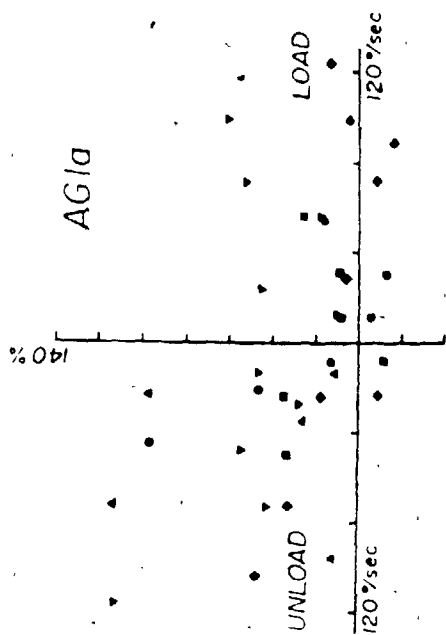

variable in each subject. Unloading prior to fast movements also produced a marked change in both components. As observed in slow movements, the increase in the first component was strongly dependent upon force magnitude. The decrease in the second component was also graded with perturbation magnitude in all subjects.

No short latency reflex activity (25-30 ms) was observed in biceps following loading perturbations or in triceps, following unloading perturbations. The appearance of long latency reflex activity (60-100 ms) was more difficult to determine especially in those movements exhibiting a reduction in response time. However, in movements where load perturbations preceded Agl onset by more than 100 ms, no reflex responses were observed (cf. Fig. 23, Load - 130 ms).

Brief perturbations applied prior to movement onset had no consistent effect on the duration of either the first or second component. Tables 4 and 5 give the percentage differences in component durations between perturbed and control movements for all subjects shown in Figs. 18 and 19. In slow movements, duration differences greater than 10 per cent of control values were distributed across most perturbation magnitudes for both load and unload conditions. No effect of either perturbation magnitude or direction on the degree of duration change was observed. In general,

TABLE 4
 Percentage change in component duration with load and unload perturbations (slow movements)

Subj	Load										AG1b
	1.0	2.0	3.0	4.0	5.0	1.0	2.0	3.0	4.0	5.0	
CC	+ 1.4 ^a	0.0	+ 1.3	-10.1	+ 1.4	+11.1	+ 7.4	+ 2.8	+ 1.4	-14.5	
DF	-10.0	+ 2.6	- 2.6	6.7	- 6.2	-11.5	+11.9	0.0	+ 5.9	-11.9	
VN	+11.1	- 5.7	+ 1.6	---	---	+ 4.8	- 7.6	-12.6	---	---	
WR	- 7.4	- 1.5	+1.6	---	---	- 3.0	+ 4.8	- 1.5	---	---	

Subj	Unload									
	1.0 ^a	1.5	2.0	3.0	4.0	1.0	1.5	2.0	3.0	4.0
CC	-11.2	- 1.3	-11.0	- 2.5	- 4.6	-16.1	-12.2	- 6.8	- 9.8	-13.7
DF	- 6.4	0.0	- 2.7	- 2.4	- 4.0	+ 4.4	0.0	- 5.8	-13.3	-11.1
VN	- 5.5	---	- 4.2	-17.6	---	- 7.6	---	-14.8	-26.7	---
WR	-10.7	---	+ 8.4	0.0	---	+ 3.0	---	+ 8.6	- 9.3	---
DC	+ 3.4	+ 3.8	- 7.1	-18.4	- 2.6	- 6.8	- 1.3	0.0	- 2.6	-1.4

^a perturbation magnitude in Newton meters (Nm)

TABLE 5
 Percentage change in component duration with load and unload perturbations (fast movements)

Subj	Load									
	Agla					Ag1b				
	1.0a	2.0	3.0	4.0	5.0	1.0	2.0	3.0	4.0	5.0
CC	+ 1.5%	-1.4	- 8.4	- 2.8	0.0	-5.9	-5.9	-7.1	+12.5	-22.3
DF	+ 5.6	-1.3	+ 7.1	0.0	-7.7	+3.5	0.0	-6.8	- 7.8	- 5.3
VH	- 7.6	0.0	- 7.3	---	---	-1.7	+7.1	-1.7	---	---
WR	-10.4	-1.7	- 4.8	---	---	-4.6	-9.2	-7.9	---	---

Subj	Unload									
	Agla					Ag1b				
	1.0a	1.5	2.0	3.0	4.0	1.0	1.5	2.0	3.0	4.0
CC	- 2.6	+8.0	+ 8.7	0.0	+2.7	-1.5	-9.4	+ 7.5	- 4.2	- 4.2
DF	+14.7	+5.6	---	+ 4.2	-9.1	+4.6	+7.9	---	+ 4.5	+ 9.7
VH	- 6.0	---	- 7.8	+23.9	---	-3.4	---	-19.4	-17.0	---
WR	- 3.1	---	+14.0	-6.8	---	-1.5	---	- 1.5	-14.0	---
DC	-10.5	-5.8	- 8.1	- 3.0	+1.5	+2.8	-4.8	- 4.7	-17.7	- 3.8

aperturbation magnitude in Mm

durations of both components associated with perturbed movements tended to be less than control values, but large differences in durations (greater than 20 per cent of control) were infrequent. Similar variation was observed for fast movements where, again, there was a tendency for component duration in perturbed movements to be somewhat less than control component durations. Duration variability within control movements was, in most cases, less than 10 per cent of mean values.

2. Changes in Agl onset time

All subjects displayed considerable variation in the onset of Agl relative to either the switch in target position or perturbation onset (time between target switch and perturbation onset remained fixed at 50 ms). This is shown for one subject in Fig. 20. In this particular subject, onset of Agl relative to perturbation onset ranged from 45 to 155 ms following loading of both slow and fast movements and from 50 to 120 ms following unloading. In contrast, Agl was always timelocked to the movement, occurring some 40-50 ms prior to movement onset (cf. Figs. 17, 18, 19). Similar ranges for Agl onset relative to perturbation onset were found in all other subjects examined. This is shown in Table 6.

In general, average response times for perturbed

Figure 20

Typical onset times of the initial agonist burst (Ag1)
relative to the onset of brief force perturbations.

Measurements (open circles) of the time between perturbation onset and Ag1 onset were obtained from individual movements in one subject. Perturbations either opposed (A - Load) or assisted (B - Unload) the forthcoming movement. In both A and B, data from slow movements are shown in the upper set of measurements while fast movements are represented by the lower set of measurements. The letters to the left of each set represent different perturbation magnitudes in Nm (a:1.0, b:1.5; c:2.0, d:3.0, e:4.0, f:5.0).

A

LOAD

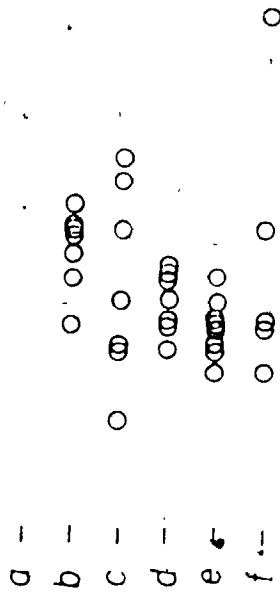

B

UNLOAD

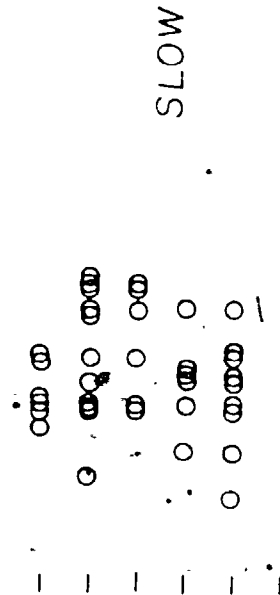

SLOW

FAST

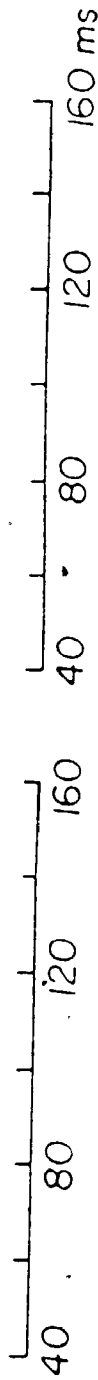
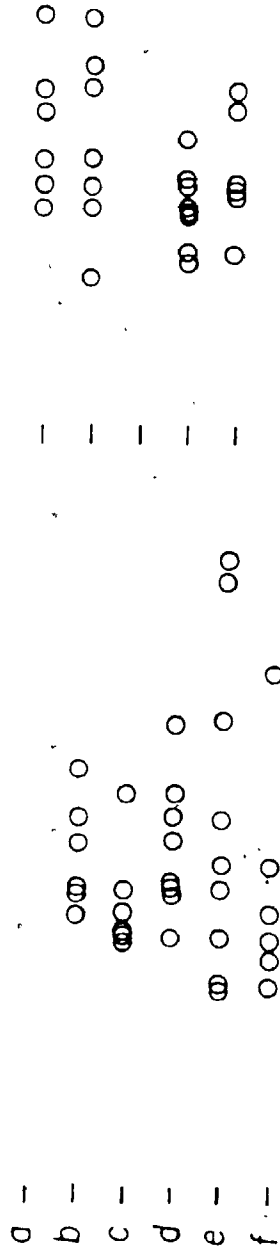

TABLE 6

Range of initial agonist burst (Agl) onset times relative
to perturbation onset

	Perturbation Magnitude (Nm)					
	1.0	1.5	2.0	3.0	4.0	5.0
<u>Slow Load</u>						
CC	40-75 ^a	—	60-145	30-95	40-70	40-65
DF	—	60-145	40-95	55-70	50-70	50-125
VN	55-80	—	70-100	50-120	—	—
WR	60-110	—	50-105	55-105	—	—
<u>Slow Unload</u>						
CC	60-100	50-95	50-95	60-100	55-105	—
DF	65-80	55-95	70-95	60-90	50-90	—
DC	80-180	55-105	70-80	40-70	—	—
VN	45-70	—	55-60	45-60	—	—
WR	70-105	—	70-100	65-100	—	—
<u>Fast Load</u>						
CC	70-90	—	60-80	45-60	60-80	60-75
DF	—	75-105	70-100	80-115	60-150	60-125
VN	55-95	—	60-80	55-85	—	—
WR	70-105	—	70-100	65-100	—	—
<u>Fast Unload</u>						
CC	60-115	80-105	80-95	60-80	65-125	—
DF	80-120	65-120	—	70-95	70-125	—
DC	70-105	40-125	55-95	65-100	70-115	—
VN	65-80	—	60-80	50-80	—	—
WR	55-70	—	60-105	55-100	—	—

^ams

movements were 5-30 per cent less than response times observed in control movements. Response times in both control and perturbed movements were measured from the time between the switch in target position and Agl onset. Since the target switched with predictable timing (every 4 sec), these measurements may not accurately reflect typical reaction times. Average response times to perturbations are shown in Table 7. Percentage change over control values are given for all subjects in Table 8. Despite the overall reduction in response time in perturbed movements, the onset of Agl relative to perturbation onset was not affected by either the magnitude or direction of the perturbation. This is shown for all subjects in Fig 21. The independence of Agl onset from perturbation onset held for both slow (A) and fast (B) movements.

3. Effects of perturbations preceding small amplitude movements

The above results show that perturbations applied prior to the onset of large amplitude movements affected both components of Agl. Small amplitude movements were also examined since these movements characteristically have initial agonist bursts of only one component. The experimental procedure was slightly modified to accommodate the small intertarget distance (15 deg.). In general, subjects

TABLE 7
Average response time for perturbed movements (time between target switch and Agl onset)

	Perturbation Magnitude (Nm)				
	1.0	1.5	2.0	3.0	5.0
Slow Unload:					
CC	159.3 ± 40.8	134.4 ± 21.9	136.0 ± 5.5	106.0 ± 11.9	110.0 ± 7.1
CP	171.5 ± 13.1	137.5 ± 16.9	135.8 ± 17.4	139.3 ± 11.7	129.4 ± 14.5
VP	146.5 ± 6.1	130.6 ± 14.2	132.3 ± 11.9	124.2 ± 9.7	121.2 ± 12.2
WR	122.1 ± 7.8	-	134.8 ± 15.5	121.7 ± 17.3	-
Slow Load:					
CC	113.3 ± 12.5	134.4 ± 25.7	152.5 ± 32.5	104.2 ± 22.4	102.5 ± 10.3
CP	-	-	119.4 ± 19.0	114.3 ± 6.1	109.4 ± 5.8
VP	115.8 ± 11.6	-	136.0 ± 17.4	118.0 ± 29.3	125.0 ± 30.0
WR	123.3 ± 17.0	-	122.1 ± 24.5	122.8 ± 18.0	-
Fast Unload:					
CC	145.0 ± 21.8	138.3 ± 10.3	140.0 ± 5.5	123.5 ± 8.4	135.8 ± 21.5
CP	156.0 ± 32.1	140.8 ± 32.8	127.1 ± 16.0	130.6 ± 13.5	-
VP	146.7 ± 14.7	143.6 ± 19.1	121.7 ± 5.6	130.6 ± 8.2	-
WR	118.6 ± 10.3	-	128.0 ± 16.8	138.5 ± 12.5	-
	112.0 ± 5.0	-	-	122.5 ± 14.1	-
Fast Load:					
CC	129.3 ± 6.4	137.5 ± 11.0	138.3 ± 7.5	131.0 ± 9.6	136.2 ± 5.8
CP	124.4 ± 14.1	-	126.3 ± 11.7	128.8 ± 14.9	130.0 ± 35.3
VP	131.1 ± 15.1	-	119.3 ± 10.2	121.3 ± 10.9	-
WR	-	-	130.6 ± 11.8	126.5 ± 10.2	-

-seen = standard deviation (ms)

Percentage difference in response time^a between perturbed and control large amplitude movements:

	<u>Perturbation Magnitude (Nm)</u>					
	1.0	1.5	2.0	3.0	4.0	5.0
<u>Slow Load</u>						
CC	-33%	-	-16%	-29%	-24%	-36%
DF	-	-25%	-37%	-35%	-31%	-32%
VN	-19%	-	+ 4%	- 5%	-	-
WR	-13%	-	-21%	- 7%	-	-
<u>Slow Unload</u>						
CC	+ 5%	-41%	- 3%	-25%	+17%	-
DC	+27%	- 9%	-28%	- 7%	- 8%	-
DF	- 2%	- 7%	- 8%	- 9%	-26%	-
VN	-16%	-	-24%	-20%	-	-
WR	+ 3%	-	- 7%	-20%	-	-
<u>Fast Load</u>						
CC	+21%	-	-29%	-13%	-22%	-20%
DF	-	- 5%	-10%	-14%	+20%	+ 2%
VN	-17%	-	-14%	-14%	-	-
WR	+13%	-	- 8%	- 3%	-	-
<u>Fast Unload</u>						
CC	+12%	-15%	-15%	-25%	+ 2%	-
DC	- 1%	- 8%	-11%	-24%	-14%	-
DF	-20%	-24%	-	- 9%	-21%	-
VN	- 7%	-	- 4%	-14%	-	-
WR	- 8%	-	-22%	- 3%	-	-

^aresponse time defined as the time between target switch and Agl onset

Figure 21

Average onset times of the initial agonist burst (Agl)
relative to perturbation onset. In A and B are shown
average onset times of Agl following onset of either
loading or unloading perturbations of different magni-
tudes. Slow movements are represented by data shown in A,
fast movements in B. Different symbols represent data from
each of five subjects and correspond to the symbols used in
Figs. 18 and 19. Each data point is the average of six to
ten movements. Vertical calibration: Agl onset in ms;
horizontal calibration: perturbation magnitude in Nm.

A

LOAD

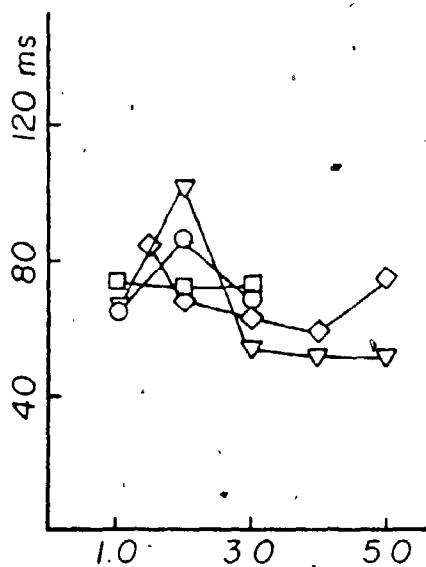

UNLOAD

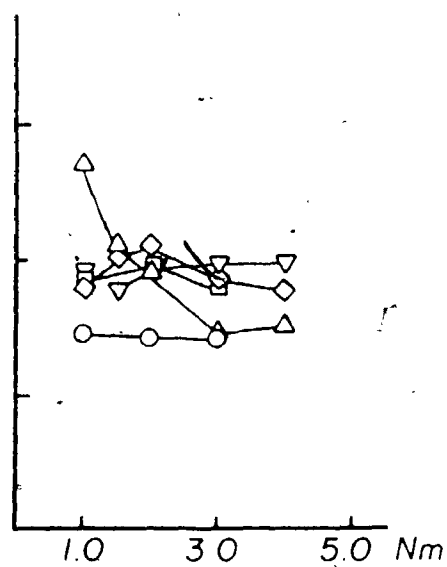

B

LOAD

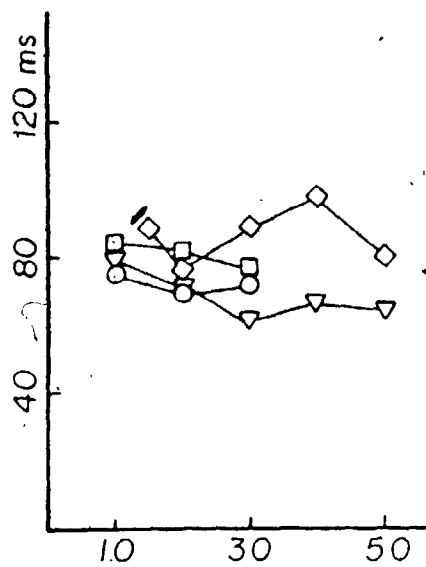

UNLOAD

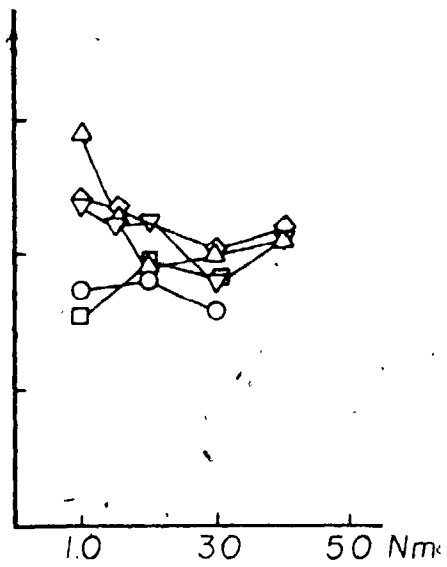

found it difficult to track the small target following unloading, and thus only two perturbation magnitudes were examined in any one subject. In addition, small movements, when made rapidly, were almost always associated with varying levels of cocontraction which made EMG analysis difficult. Therefore, subjects were asked to make slow, accurate movements during all experimental trials involving these small amplitude movements.

Typical records from one subject are shown in Fig. 22. In these movements Agl consisted of only one component. The timing of this component identifies it as corresponding to the first component (Agl₁) seen in large amplitude movements. Averaging of data around movement onset resulted in an apparent increase in Agl duration from approximately 70 to 100 ms. Agl increased in magnitude with both loading and unloading. The increase in magnitude depended on the strength of the perturbation. For both loading and unloading, large perturbations (4.0 Nm) produced a greater increase in burst magnitude than did smaller perturbations (3.0 Nm). Although more striking in movements which were unloaded, this dependence on force magnitude was consistent for both conditions in all three subjects.

As shown earlier for large movements, the onset of Agl was not timelocked to perturbation onset. Individual variation in timing between perturbation onset and Agl onset is clearly illustrated in Fig. 23 which shows individual

Figure 22

Effects of perturbations preceding small amplitude movements. In each set of records (Load and Unload) the top two traces show movement velocity and agonist EMG activity from non-perturbed (control) 15 deg movements. The bottom two records show EMG data obtained from movements which were preceded by perturbations. The vertical dashed lines indicate the onset and termination of the initial agonist burst. The range of perturbation onset times is indicated by the horizontal bar below the EMG records. The numbers to the left of the records represent perturbation magnitude in Nm. Data are shown from one subject. Each record is the average of five to seven movements synchronized around movement onset. Vertical calibration: 100 deg/s. Time scale in ms.

LOAD

UNLOAD

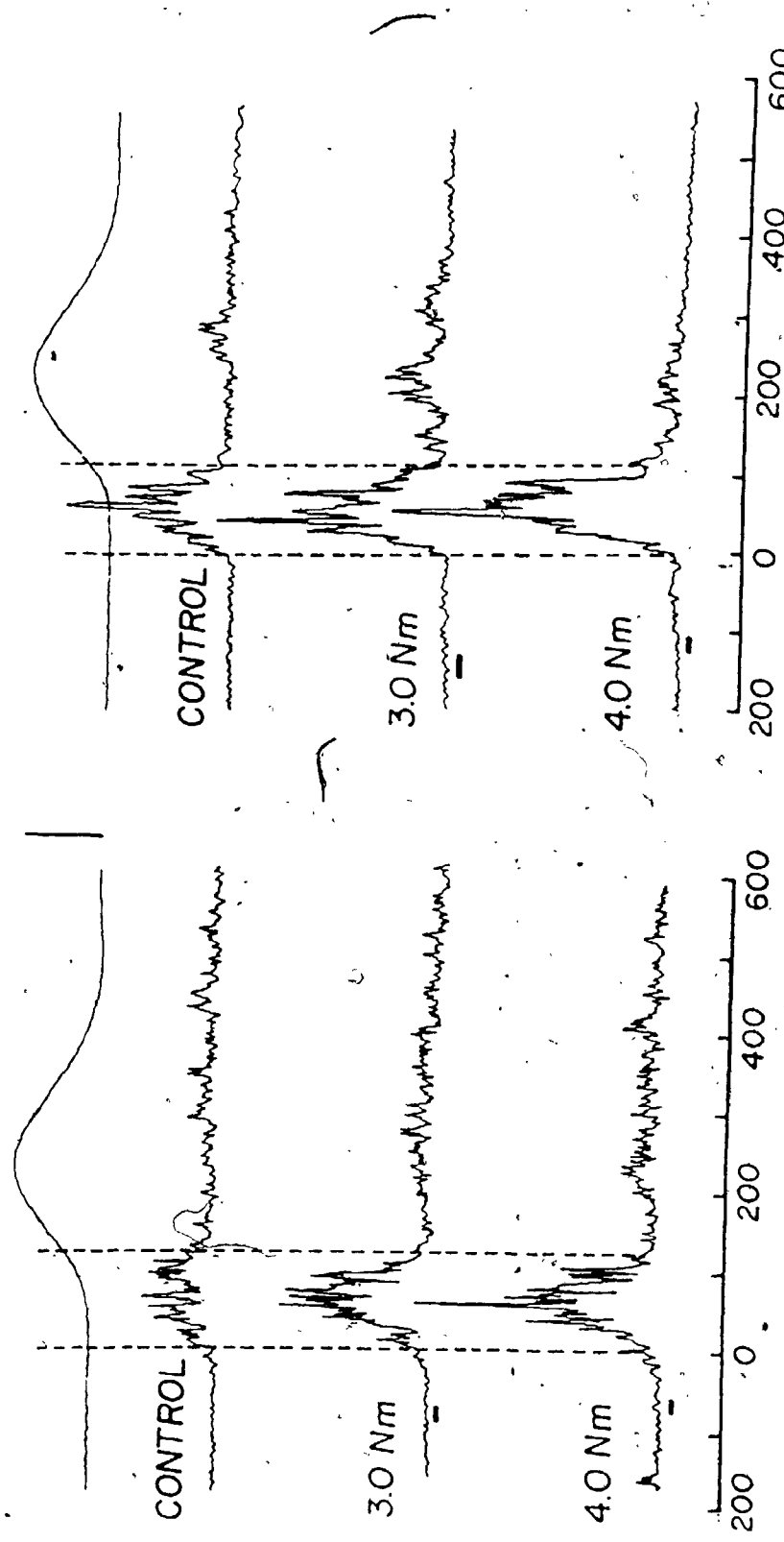
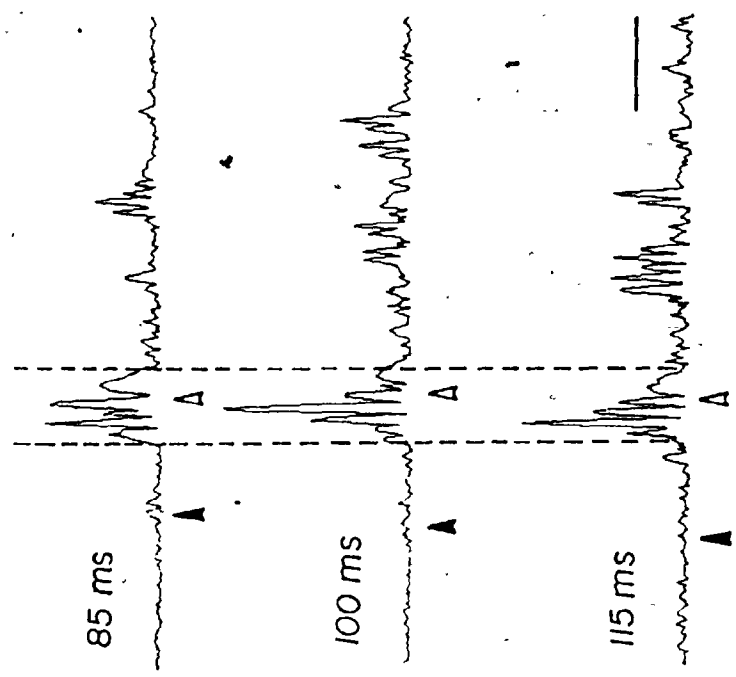

Figure 23

Variability in initial agonist burst (Agl) onset times relative to perturbation onset. Individual agonist EMG records associated with 15 deg slow flexion movements are shown for one subject. The vertical dashed lines indicate onset and termination of Agl. Filled arrows indicate perturbation onset and open arrow, movement onset. Time between perturbation onset and EMG onset is given by the number to the left of each record. Horizontal calibration: 100 ms.

UNLOAD



LOAD

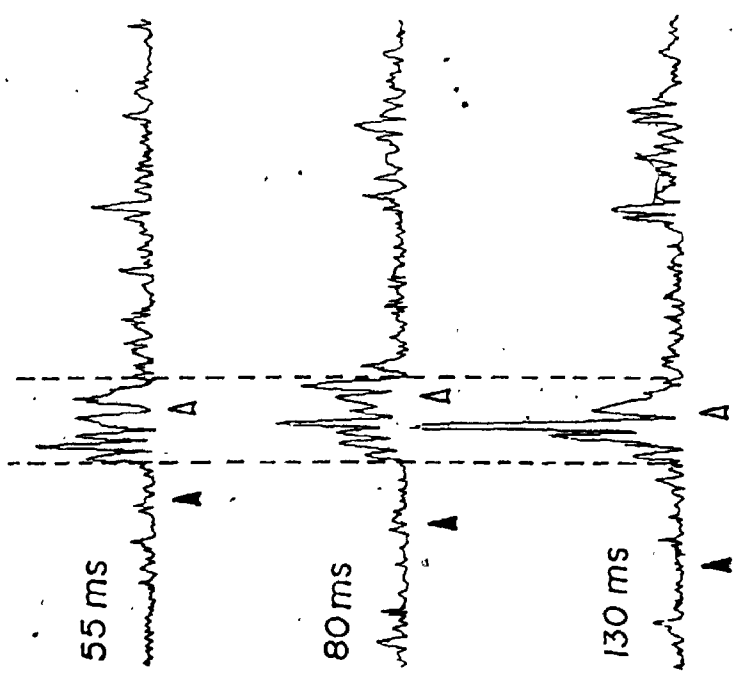

records of EMG activity from one subject. Onset of the first component relative to the onset of loading perturbations (Load - filled arrows) ranged from 55 to 130 ms in these movements. A similar range of latencies is shown for unloading perturbations (Unload) where Ag1 onset times ranged from 85 to 115 ms. With both loading and unloading, however, the onset of the first component was timelocked to the onset of movement (open arrows). As observed in large amplitude movements, a reduction in response time following both loading and unloading perturbations compared to control movements was seen. (Table 9). In general, there was no apparent relationship between response time and perturbation magnitude or direction.

B. Effects of starting position on the initial agonist burst

As shown in the preceding section, both components of the initial agonist burst were modulated independently by the central nervous system in response to unexpected peripheral disturbances. In those experiments initial starting position was kept constant from trial to trial and, as a result, resting (tonic) EMG activity did not change. It is known that tonic muscle activity varies with static limb position (Lestienne et al., 1981; Cooke and Brown, 1983), these changes reflecting differences in muscle force

TABLE 9

111

Percentage difference in response^a time between perturbed and control small amplitude movements

	<u>Perturbation Magnitude (Nm)</u>			
	2.0	3.0	3.5	4.5
<u>Load</u>				
SS	-18%	-	-20%	-
VN	-	-28%	-	-21%
DC	-	-24%	-	-38%
<u>Unload</u>				
SS	-12%	-	-25%	-
VN	-	-26%	-	-23%
DC	-11%	-	-15%	-

^aresponse time defined as the time between target switch and Agl onset.

output required to hold the limb in a given position. For instance, holding the elbow in an extended position requires increased tonic activation of the triceps muscle relative to tonic biceps activity. Experiments were performed to determine if static force changes with different limb positions might be sufficient to alter phasic drive to the agonist muscle.

1. Baseline EMG correction

Ten degree movements were made from seven different starting positions. For a given experiment, each subject was encouraged to maintain movement peak velocity constant from trial to trial. As expected, tonic EMG activity varied with different starting positions. This is shown for one subject in Fig. 24. As movements were made from progressively more extended positions, tonic triceps activity (prior to movement) increased relative to premovement tonic biceps activity. In more flexed positions tonic biceps activity increased relative to triceps activity.

Because of these changes in tonic EMG activity with limb position, it was necessary to express integrated Agl magnitudes as a percentage change over baseline control EMG values. Two methods of baseline EMG correction were examined. In the first method, tonic EMG activity was

Figure 24

Baseline correction of phasic EMG activity for position-dependent changes in tonic EMG activity. In A are shown the relation between tonic biceps (filled circles) and triceps (open circles) EMG activity, associated with different starting positions. Each data point is the average of twenty movements obtained from one subject. EMG burst magnitudes following correction for tonic background activity are shown for the same subject in B. Data were obtained from 10 deg slow flexion movements about the elbow made from different starting positions. Each data point is the average of twelve to twenty movements. Circles represent the initial agonist burst (Ag1); squares, second agonist burst (Ag2) and triangle, antagonist burst (Ant1). Open symbols show data corrected by subtracting the tonic activity at each starting position. Filled symbols show data corrected by subtracting the minimum tonic EMG activity observed across all starting positions. Stippled areas indicate the differences in EMG magnitudes resulting from these two methods of background EMG correction. Vertical axes: A - EMG magnitude in arbitrary units, B - percentage increase in phasic EMG activity over tonic background EMG activity. Horizontal axes: A and B - elbow angle (starting position) in deg (180 deg equivalent to full extension).

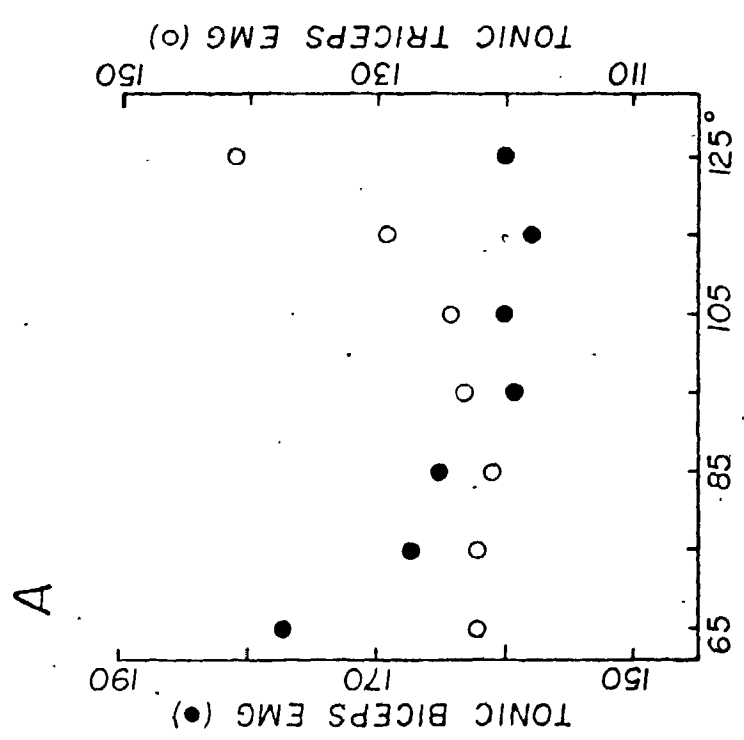
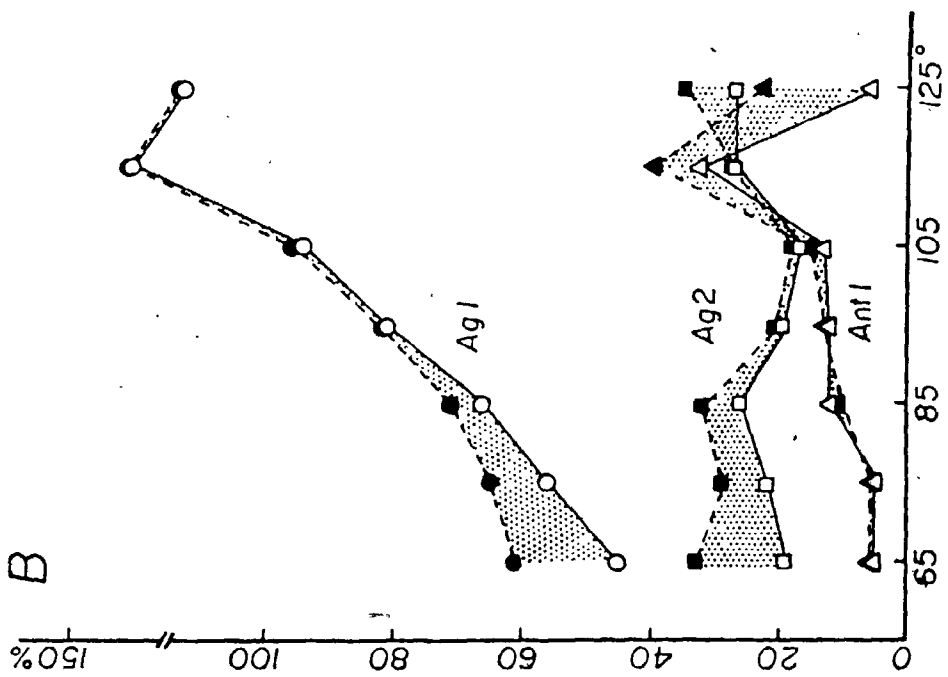

subtracted from the integrated EMG value of the phasic bursts. As the tonic activity varied with starting position (Fig. 24A), a different correction value was used for each initial arm position. The open circles in Fig. 24B show data corrected by this method for the initial agonist burst (Ag1), second agonist burst (Ag2), and the antagonist burst (Ant1) at different starting positions. In the second method of correction for background activity, the minimum tonic activity observed across all starting positions was subtracted from each integrated EMG value. For example, tonic agonist (biceps) activity was minimal in the most extended position. This value was then subtracted from all agonist burst magnitude values. Data corrected in this manner are shown by the filled circles in Fig. 24B. Both methods of baseline correction resulted in an increase in Ag1 magnitude as starting position became more extended. In relatively flexed positions where tonic agonist activity increased, baseline correction using the minimum tonic agonist EMG level produced a smaller increase in Ag1 magnitude compared to Ag1 magnitude values determined by the first correction method. Similarly, each method produced a slightly different magnitude value for the antagonist burst associated with extended initial starting positions.

Although these two methods of correction for background EMG activity yielded different relations, the differences were quantitative rather than qualitative. In some subjects

phasic antagonist activity associated with extended starting positions were preceded by a period of antagonist inhibition. Under these conditions, the integrated magnitude of the antagonist burst in some movements did not exceed tonic premovement EMG levels so that baseline correction using the first method actually resulted in a negative value. Because of this, subtraction of the minimum tonic EMG level from all positions was employed throughout the study as a means of baseline EMG correction.

2. Changes in phasic EMG activity with different starting positions

Since Agl magnitude varies with movement peak velocity (Hallett and Marsden, 1979; Brown and Cooke, 1981a), subjects were encouraged to produce movements of comparable speed at each starting position. In general, average peak velocity was unaffected by changes in starting position. This is shown for five subjects in Fig. 25A and Table 10. Although average velocities varied considerably from subject to subject, the variability from one starting position to another for any given subject was small. In addition, movement duration remained relatively constant for each subject across different joint angles (Fig. 25B, Table 10). While there was a tendency for movement duration to decrease

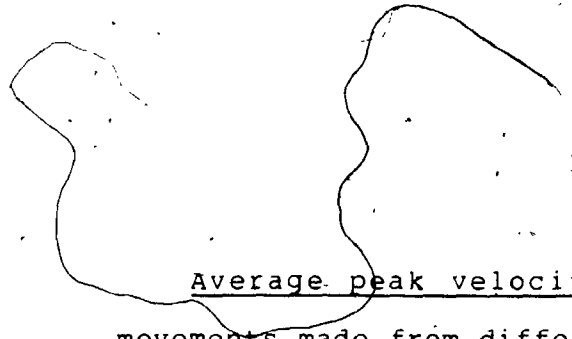

Figure 25

Average peak velocities and movement durations for movements made from different starting positions. Data are shown for five subjects (different symbols). Each point is the average of eighteen to twenty 10 deg slow flexion movements. Verbal feedback regarding movement speed during the two to three min practice period prior to data collection was given so as to assist each subject in matching peak velocities. Vertical axis: peak velocity in deg/s, horizontal axis: elbow angle in deg.

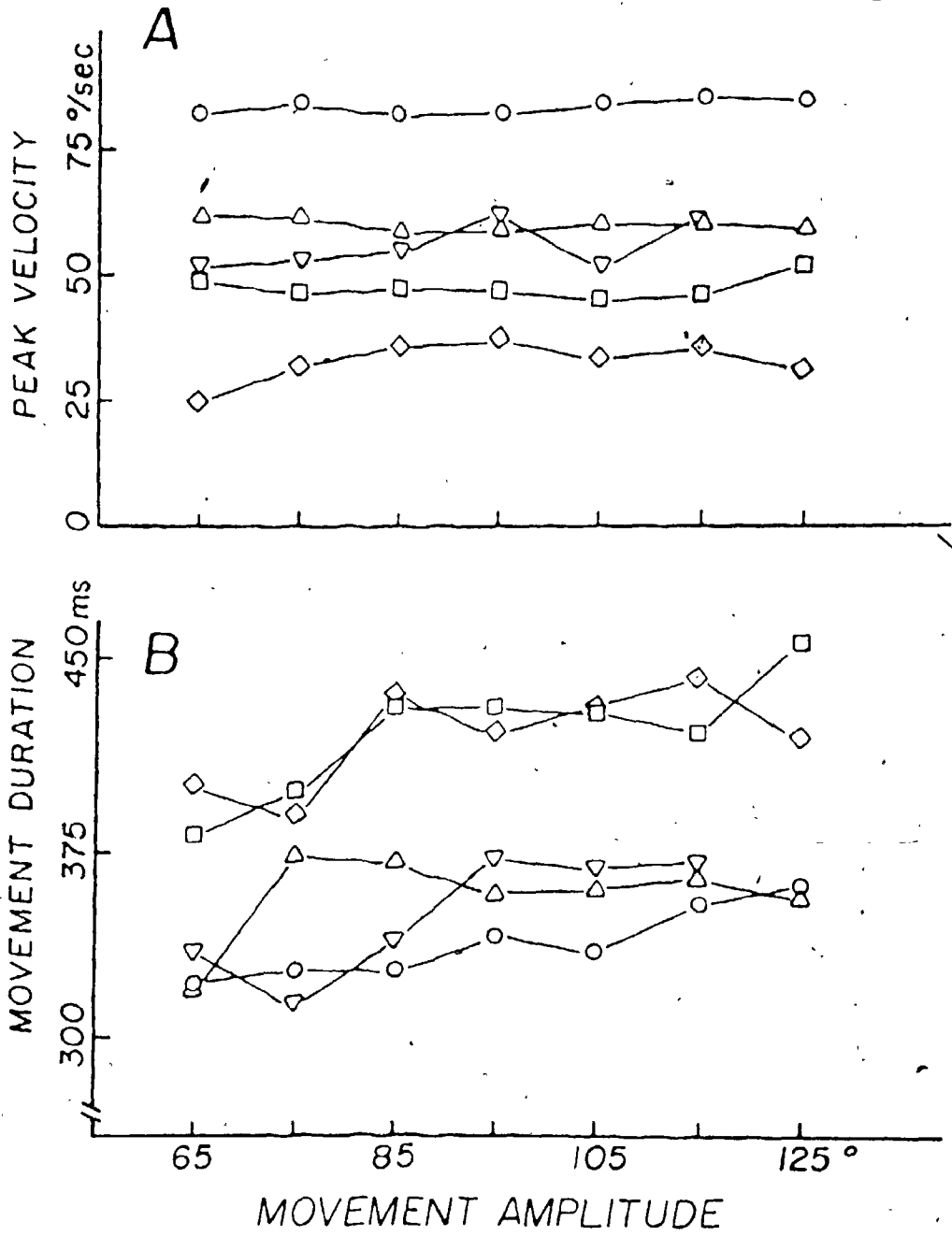

TABLE 10

Average peak velocity and movement duration values associated with movements made from different starting positions.

	Initial starting position (deg)						
	65	75	85	95	105	115	125
	<u>Peak Velocity</u>						
SS	82± 1.7 ^a (13)	84± 1.4 (18)	83± 1.7 (13)	82± 1.6 (15)	84± 1.5 (17)	86± 1.5 (16)	85± 1.5 (14)
DC	49± 0.8 (16)	47± 1.2 (17)	47± 0.8 (16)	47± 1.2 (13)	45± 0.9 (20)	47± 2.9 (18)	52± 1.1 (15)
KW	61± 2.1 (12)	61± 1.4 (13)	58± 1.6 (15)	58± 0.9 (20)	60± 2.7 (10)	60± 1.8 (17)	58± 1.7 (18)
CB	25± 1.2 (13)	32± 1.3 (11)	37± 1.7 (14)	38± 1.8 (16)	33± 0.8 (17)	36± 1.5 (13)	31± 2.1 (15)
JB	52± 4.5 (6)	53± 2.3 (10)	55± 2.3 (8)	62± 2.0 (13)	52± 2.2 (11)	61± 1.6 (15)	---
	<u>Movement Duration</u>						
SS	322± 6.4 ^b	326± 4.6	328± 6.3	340± 4.8	334± 6.5	352± 3.1	359± 4.7
DC	380± 6.2	397± 10.0	430± 10.0	430± 11.0	428± 4.8	420± 0.9	456± 8.8
KW	320± 5.8	370± 6.6	368± 11.8	356± 6.6	358± 9.7	362± 10.8	355± 5.3
CB	399± 10.7	388± 6.0	435± 13.0	420± 10.1	433± 10.2	442± 8.1	418± 6.7
JB	334± 7.6	314± 6.0	338± 7.9	369± 7.2	366± 10.1	368± 5.8	---

^amean ± S.E. in deg/s

^bmean ± S.E. in ms

in movements made from more flexed positions, a comparison of durations associated with the most flexed (65 deg) and most extended (125 deg) starting positions showed a less than 20 per cent difference. For starting positions ranging from 85 to 125 deg, movement duration varied by only ten per cent. As will be described in more detail later in this section, movements made from the different starting positions were closely matched in both their time course and their position-velocity (phase-plane) trajectories.

Movements made from all starting positions were initiated by phasic EMG activity. In Fig. 26 are shown average records of EMG activity associated with 10 deg flexion movements made from different positions (A - F). At all starting positions, Ag1 consisted of only one component of activity, the duration of which was approximately 70-80 ms. The magnitude of Ag1, however, increased as starting position became more extended. Both late agonist activity (Ag2) and phasic antagonist activity (Ant1 - cf. Fig. 27) were also more pronounced in extended compared to more flexed positions. As expected, tonic EMG activity prior to movement varied with the changes in joint angle. As the starting position became more flexed, tonic agonist activity increased. Conversely, tonic antagonist activity increased in the more extended positions. Inhibition of tonic antagonist activity both before and during the time of Ag1 was often seen in movements made from the most extended

Figure 26

EMG activity associated with 10 deg slow flexion movements made from different starting positions. Each set of data shows average records of position, velocity, biceps and triceps EMG activity from one subject. Initial starting position ranged from 65 deg (A) to 125 deg (F). Each set of records is the average of eighteen to twenty movements. Vertical calibration: 20 deg, 200 deg/s; horizontal calibration: 200 ms.

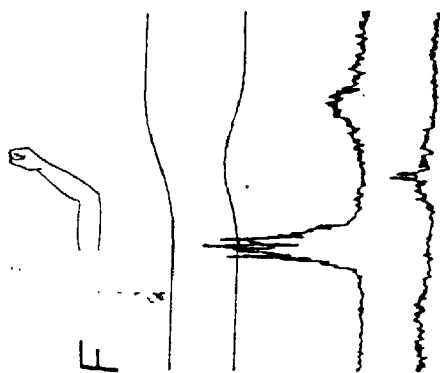
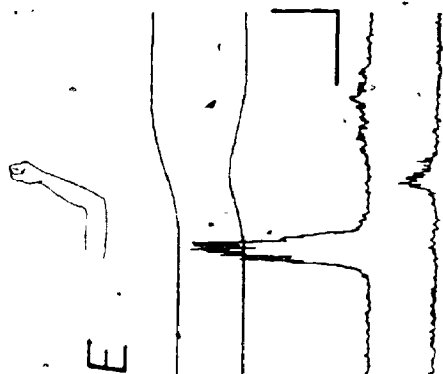
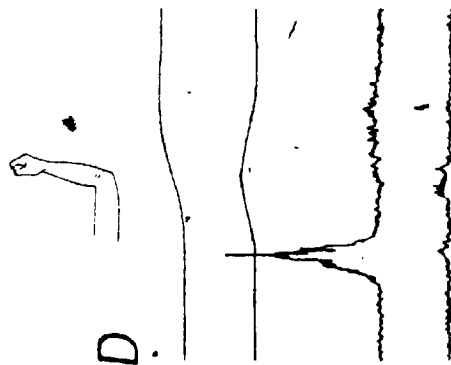
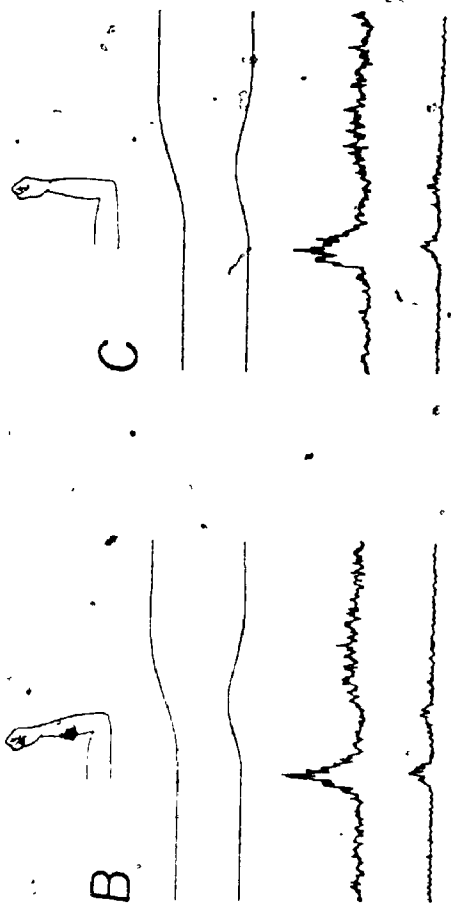
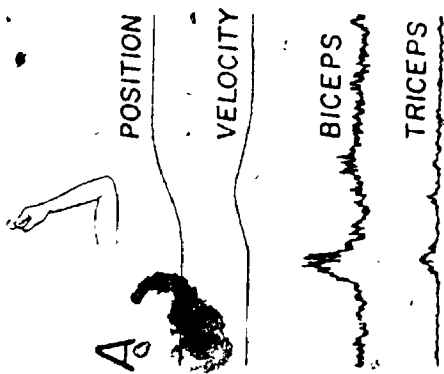

1

positions (Fig. 26F). The changes in the magnitudes of the phasic EMG bursts with starting position are shown for five subjects in Fig. 27. EMG magnitudes are expressed relative to the minimum background activity, i.e. (integrated EMG - background) / background. In all but one subject, Ag1 increased in magnitude as joint angle increased. In one subject (diamond symbols) little overall change in the magnitude of Ag1 occurred. However, most movements made by this subject showed a reduction in tonic antagonist activity preceding the antagonist burst (cf. Fig. 26F). This will be discussed in more detail in relation to Fig. 29. In one other subject, Ag1 decreased in magnitude at the most extended position (open triangle, 125 deg). In these particular movements, however, there was a period of marked antagonist inhibition preceding the phasic antagonist burst (cf. Fig. 26F).

The second agonist burst (Ag2) was observed in only two subjects. This was presumably due to the relatively slow speed of these movements (Brown and Cooke, 1981a). In one subject (square symbols) Ag2 activity was minimal in movements made from midrange positions (85-105 deg) while a tendency to increase in magnitude was observed in the most flexed and extended positions. In the second subject (circles) Ag2 increased in magnitude as starting position shifted from midrange to extended positions.

In three of the five subjects examined, phasic antago-

Figure 27

Dependence of phasic EMG magnitude on starting position of the limb. In this figure are shown average magnitudes for the various EMG bursts. Data were obtained from five subjects (different symbols) each of whom performed a series of 10 deg slow flexion movements from different starting positions. Phasic agonist bursts are represented by the upper graphs (Ag1 - initial agonist burst, Ag2 - second agonist burst), phasic antagonist activity is represented by the lower graphs (AntCo - period of increased antagonist activity coincident with Ag1), Ant1 - phasic antagonist burst occurring at or just prior to the time of peak velocity). Each symbol in all graphs represents data obtained from the same subject. Vertical axes: percentage increase in phasic EMG activity over tonic background EMG levels; horizontal axis: elbow angle in deg.

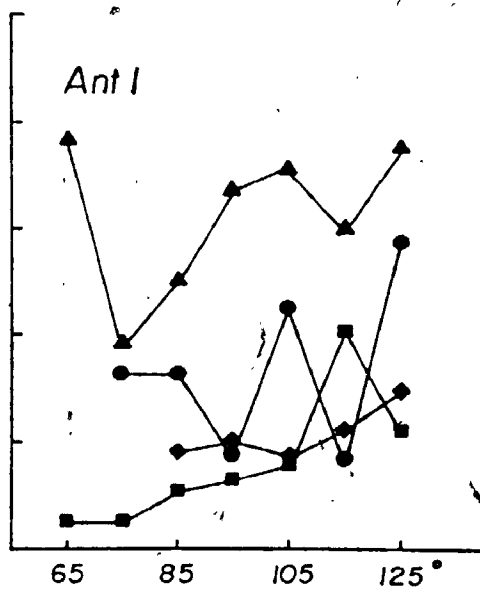
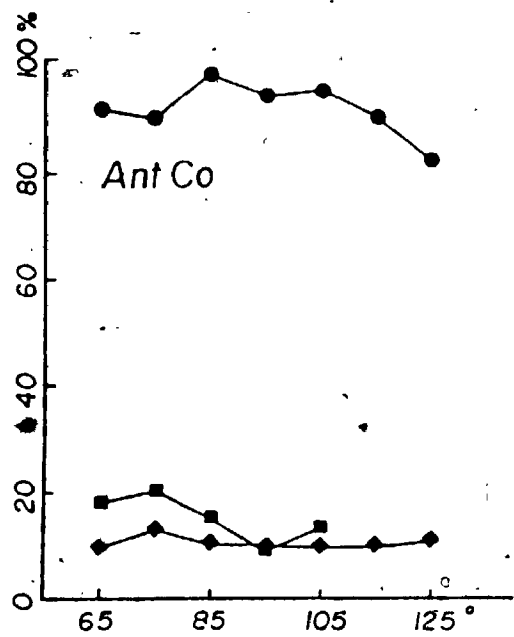
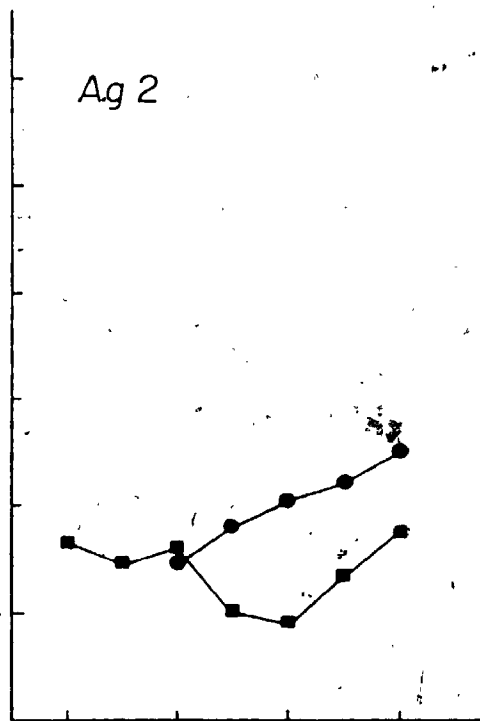
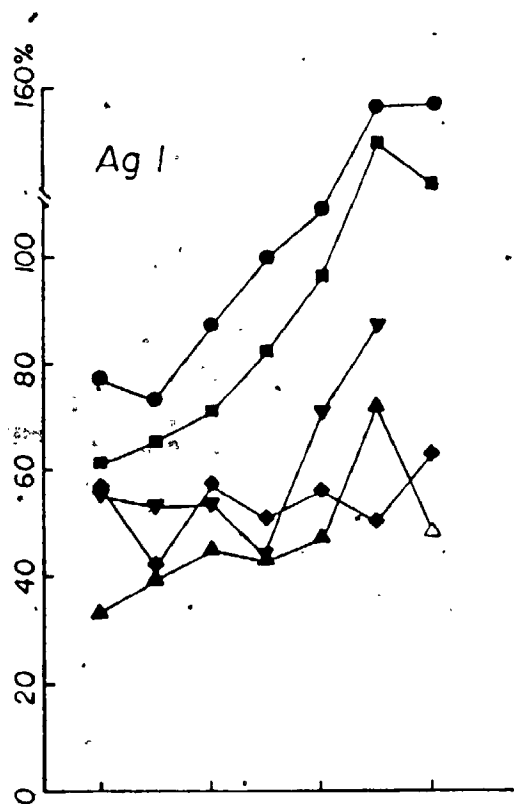

nist activity consisted of two bursts, the first coincident with Agl and the second corresponding to the typical antagonist burst associated with the triphasic pattern of EMG activation (cf. Fig 26B). The early burst of antagonist activity (AntCo) tended to decrease in magnitude (e.g. Fig. 26), or show little change as joint angle increased. Data from three subjects showing this period of antagonist co-contraction is shown in Fig. 27. Of particular interest was that, in some subjects, this early antagonist burst was present in movements made from the most extended positions, i.e. during the period of antagonist inhibition. The antagonist burst commonly associated with the triphasic pattern (Ant1) varied unpredictably with joint angle and, in general, showed no consistent pattern of change.

The increase in Agl magnitude in extended positions also occurred in large amplitude movements. Typical data from 40 deg movements made by one subject are shown in Fig. 28. Agl in these large movements was comprised of two components. The magnitude of both components increased at more extended starting positions. As was seen in the 10 deg movements, a period of antagonist inhibition preceded Agl at the most extended positions. This period of inhibition was followed by increased antagonist activity. Similar results were found in four subjects.

Figure 28

EMG activity associated with 40 deg, slow flexion movements made from different starting positions. In each set of data (A - C) are shown average (n=15) records of position, velocity, biceps and triceps EMG activity obtained from one subject. Starting position was 85 deg in A, 105 deg in B, and 135 deg in C. Each subject was instructed to make each set of movements at the same speed. Vertical calibration: 25 deg, 200 deg/s; horizontal calibration: 200 ms.

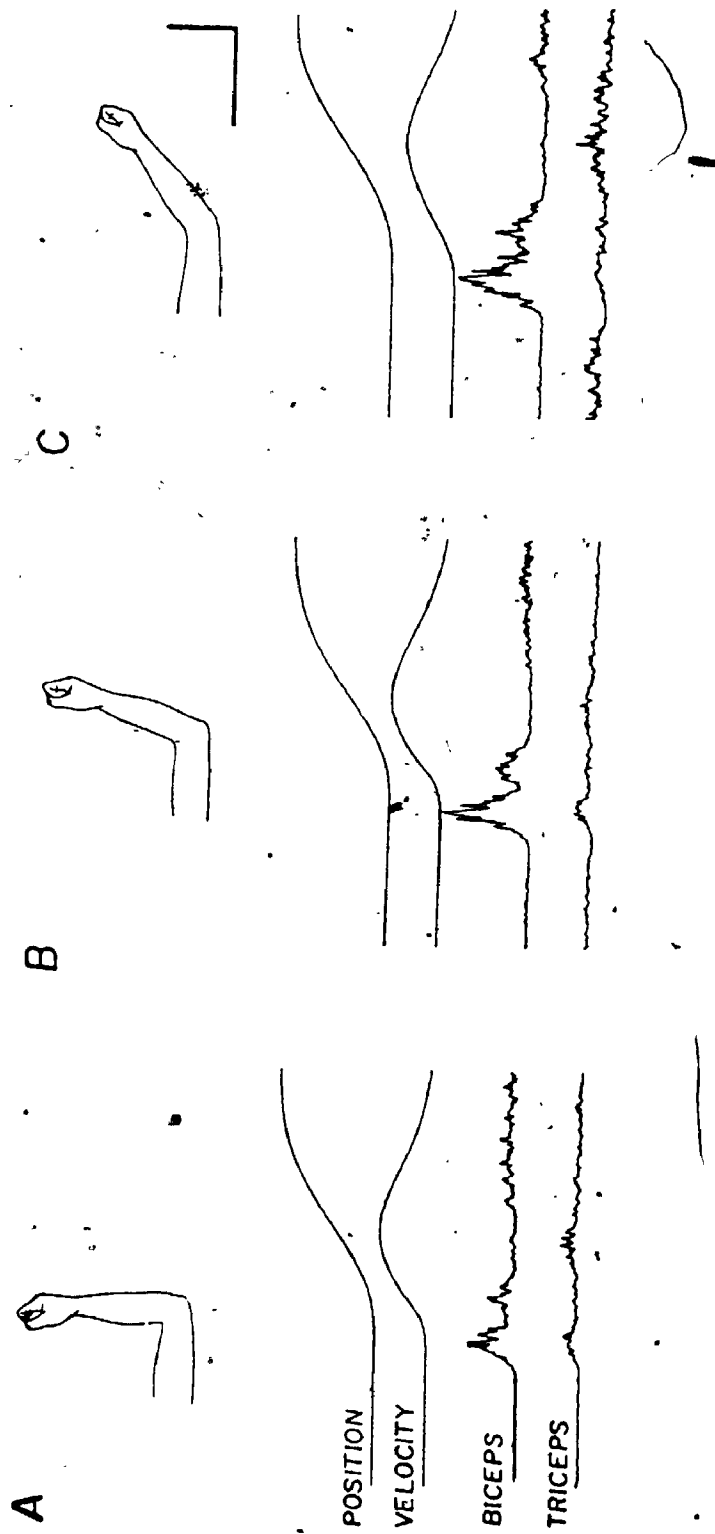

3. Comparison of movement trajectories

Although phasic EMG activity varied with starting position, movements showed little difference in their peak velocities or durations (cf Fig. 25). In addition, movements made from different starting positions were virtually identical throughout their course. In Fig. 29 movement phase-plane trajectories (velocity versus position) are shown for two subjects. The data shown in Fig 29A correspond to the square symbols in Figs. 25 and 27. In this subject Ag1 (open bars) increased markedly as starting position changed from 65 deg (left hand bar in each set) to 125 deg (right hand bar in each set). The antagonist burst (filled bars) was relatively small in this subject in movements made from starting positions less than 125 deg (Ant1 magnitude increased above background EMG levels by less than 20 per cent and are not included in the histogram. In this subject, a period of antagonist inhibition (stippled bars) was only seen in movements made from the most extended positions (115,125 deg).

In contrast, the second subject (B), showed little change in burst magnitude with starting position. This data corresponds to the diamond symbols in Figs. 25 and 27. While agonist activity did not increase with extension there was, at all but the most flexed positions, a period of antagonist inhibition (stippled bars) preceding and coinci-

Figure 29

Movement trajectories associated with position-dependent changes in phasic EMG activity. Each set of open bars, represents the magnitude of the initial agonist burst (Agl) as starting position changed in ~~10~~ deg increments from 65 deg (left hand bar in each set) to 125 deg (right hand bar in each set). Phasic antagonist activity is shown by the solid bars and the duration of antagonist inhibition by the stippled bars. Each bar is the average of twelve to twenty movements. EMG magnitude is in arbitrary units, duration is in ms. Position-velocity (phase-plane) trajectories of movements made at different arm positions are shown below each histogram. The starred bars in each histogram indicate the movements whose trajectories are plotted below. Arrows indicate the direction of movement.

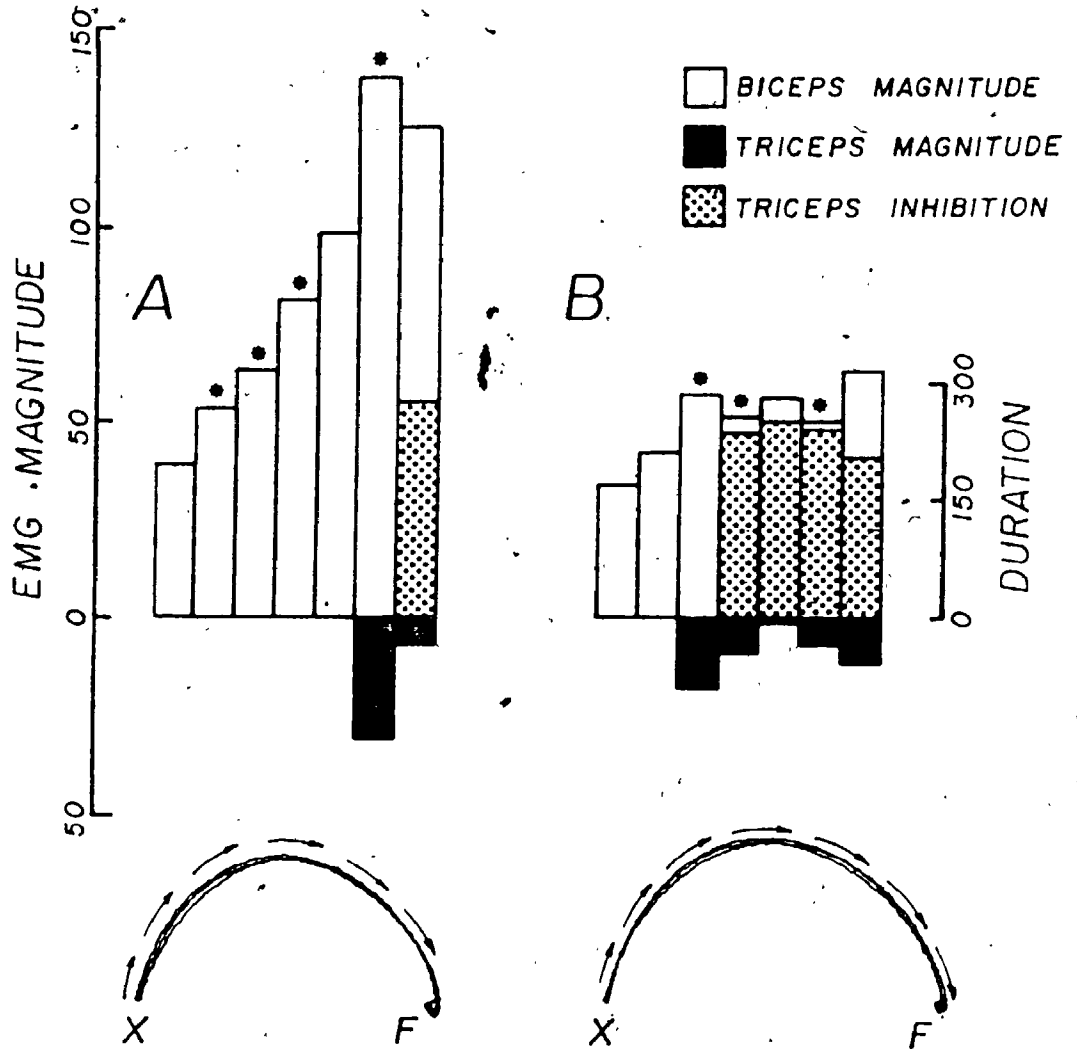

dent with Agl.

While agonist (Fig. 29A) or antagonist (Fig. 29B) EMG activity changed with starting position, the resulting movements were virtually identical. In Fig. 29 phase-plane trajectories of movements made from the different starting positions indicated by the starred histogram bars are overplotted below each histogram. Although EMG activity varied from one starting position to another, the resulting trajectories were virtually unchanged. While most subjects showed a progressive increase in Agl magnitude as joint angle increased (e.g. Fig. 29A), some subjects combined a modest increase in agonist magnitude with a period of antagonist inhibition in movements made from the most extended positions. This was previously noted in Fig. 27 where one subject (triangles) exhibited a decrease in agonist magnitude at 125 deg coupled with a period of antagonist inhibition. In this particular subject, movement trajectories associated with the two most extended positions (115 and 125 deg) were essentially identical.

4. Effects of changing equilibrium position on phasic EMG position.

One possible explanation for the observed position-dependent changes in phasic EMG activity could be related to the associated changes in tonic EMG activity. For example,

the increase in Ag1 with extension might be due to the need for increased agonist activity to overcome the elevated tonic antagonist activity in extension. This was tested by applying a small, steady load to the handle which displaced the relaxed limb into an extended position (125 deg joint angle). Thus, the arm could be maintained at this position without the usual increased triceps activation. The effects of such a shift in equilibrium position (the position at which net forces acting about a joint are zero) are shown in Fig. 30. Average records in Fig. 30A and B show the characteristic triphasic EMG pattern and, in particular, the increase in agonist burst magnitude (in this case both Ag1 and Ag2) as the limb became more extended (stippled bars in the histograms). Shifting the limb equilibrium position (Fig. 30C) decreased the amount of tonic antagonist drive required to hold the limb in extension prior to movement (open histogram bars). The agonist bursts were greater than in the flexed position (Fig. 30A) but little changed from those in the same position when no force was applied (Fig. 30B).

III. Phasic EMG Activity Associated with Changes in Movement Trajectory

In general, both single and multi joint movements are

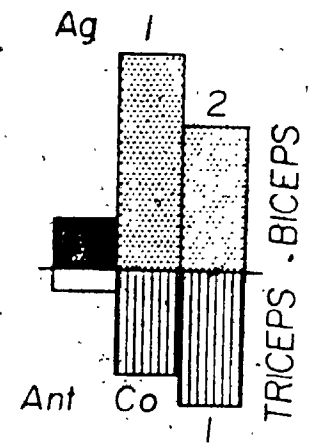
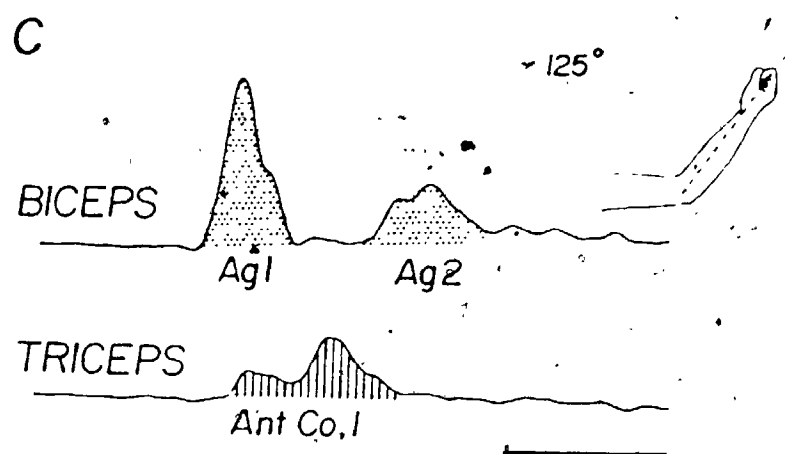
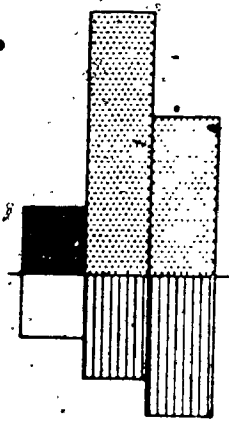
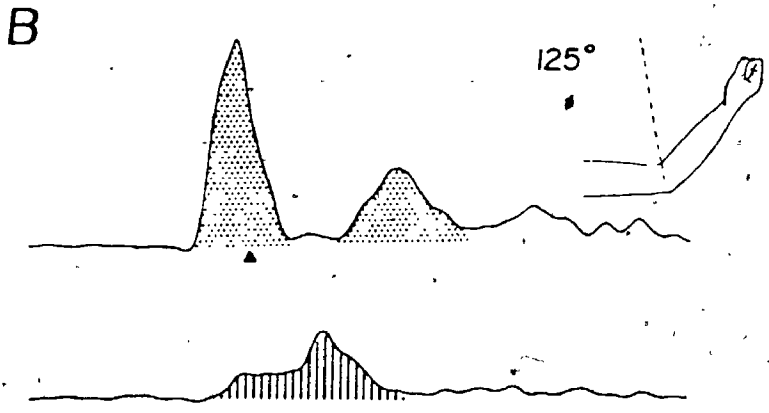
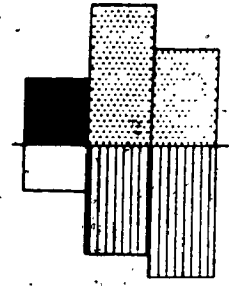
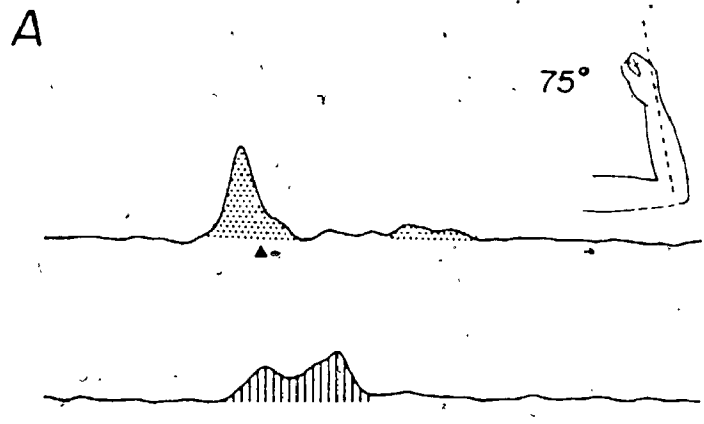

Figure 30

Effects of changing passive limb equilibrium position on movement-related EMG activity. Agonist (biceps) and antagonist (triceps) activity associated with 10 deg slow flexion movements made from two different starting positions are shown for one subject in A and B. Passive equilibrium position of the limb in both A and B was approximately 75 deg as indicated by the dashed lines. In C, application of a small, steady force shifted equilibrium position from 75 to 125 deg. Each set of records (A - C) is the average of eight to ten movements. A comparison of phasic EMG activity is shown in the corresponding histograms to the right of each set of EMG records. Stippled areas in both EMG records and histograms show phasic agonist activity (Ag1 and Ag2) and hatched areas show phasic antagonist activity (AntCo and Antl). Tonic agonist EMG activity is shown by the solid bars and tonic antagonist activity by the open bars.



200 ms

associated with bell-shaped, symmetrical trajectories in which the durations of the acceleratory and deceleratory phases are approximately equal. The movements described in the preceding sections were characterized by such symmetrical velocity profiles. To determine if changes in Agl were related to changes in the initial acceleratory phase of the movement, a phase-plane trajectory tracking paradigm was employed (see Methods, Section IIC; Cooke and Brown, 1986). Using this tracking technique, it was possible to vary the ratio of acceleration duration to deceleration duration while, at the same time, keeping movement amplitude and peak velocity constant.

Typical examples of movements made by this technique are shown for one subject in Fig. 31. Average records of velocity, acceleration, agonist (triceps) and antagonist (biceps) EMG activity associated with 40 deg extension movements are shown for three different movement acceleration - deceleration duration ratios (A = 0.4; b = 0.9; C = 1.4). Movement profiles comparable to those seen in step-tracking movements are shown in B and, as expected, velocity and acceleration records were symmetrical in appearance. Similarly, the associated agonist EMG record (B) showed an initial agonist burst of approximately 160 ms in duration. Although obscured by averaging, inspection of individual records showed that Agl was comprised of two components of activity. As seen in step-tracking movements,

Figure 31

Effects of changing movement profile on phasic EMG activity. In this figure are shown averaged ($n = 6-10$) records of velocity, acceleration and EMG activity obtained from 40 deg extension movements about the elbow. Velocity and acceleration records are overplotted to illustrate different movement profiles. The upper set of EMG records (A) correspond to rapid acceleration movements (A). The middle set of records (B) correspond to movements in which durations of the acceleratory and deceleratory phases were approximately equal (acceleration record B). The lower set of records corresponds to slow acceleration movements (C). Filled arrows indicate time of peak velocity. In all cases, movement amplitude, duration and peak velocity remained constant. In averaging movements with a ratio of > 1.0 , time of peak velocity was used to synchronize movements. All other movements were synchronized about movement onset.

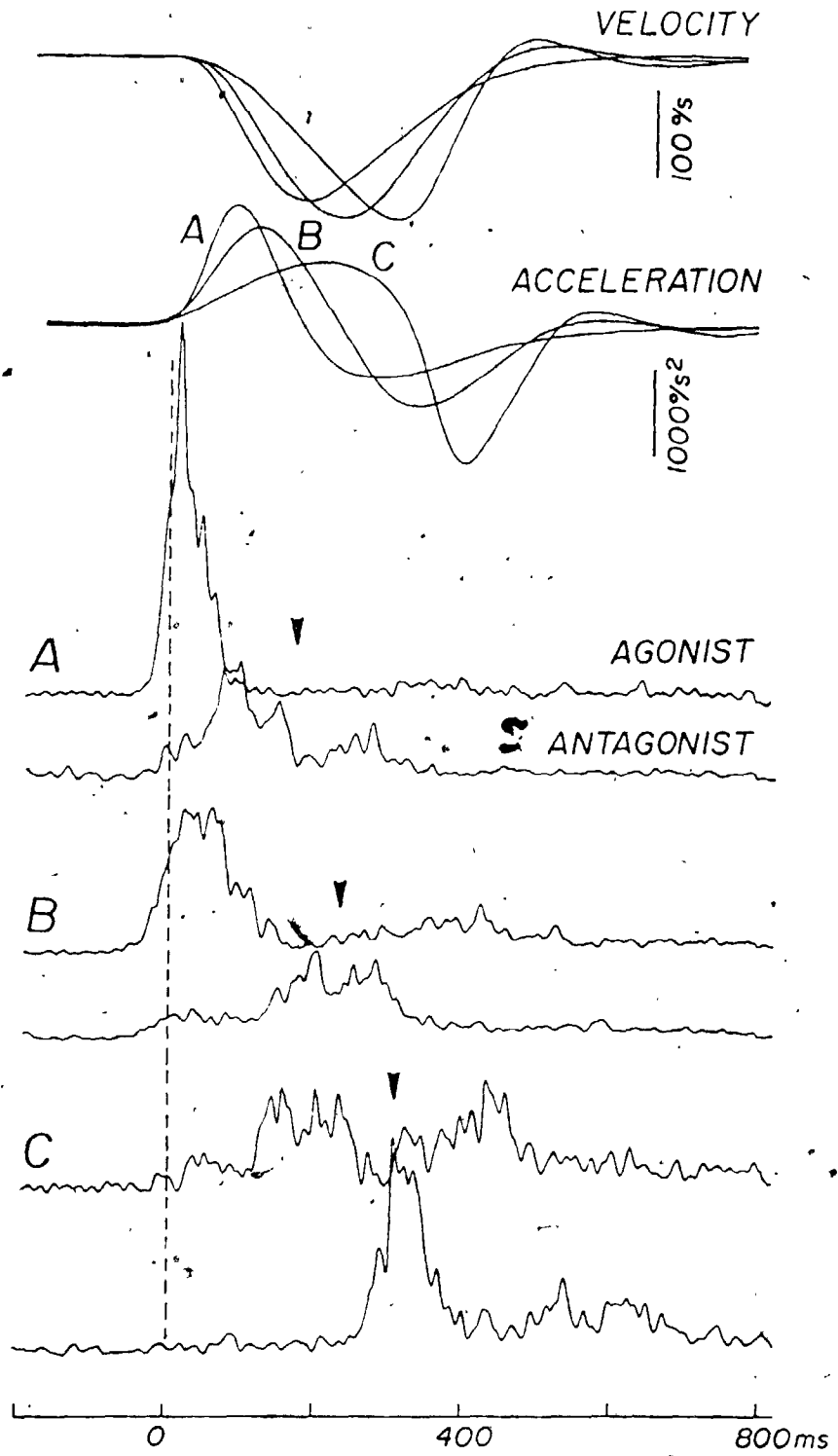

phasic antagonist activity occurred near or at the time of peak velocity (filled arrows). A period of early antagonist activity (AntCo) coactive with Agl was also seen in these movements. Early antagonist activity was also observed in step-tracking movements (cf. Figs 26A - C, 28 A and B).

In contrast, movements made with a movement ratio of 0.4 (A) were associated with an initial agonist burst of approximately 90 ms. Inspection of individual records comprising this average showed that Agl consisted of only one component. In these short acceleration - long deceleration movements, not only did Agl duration decrease but onset of phasic antagonist activity occurred earlier relative to movement onset. This will be discussed further in relation to Fig. 34. No late phasic agonist activity was observed.

2
Movements made with a movement ratio of 1.4 (C) showed a very different pattern of EMG activation compared to movements in A or B. In these movements (C), Agl appeared to be comprised of both tonic and phasic activity. A gradual increase in activity occurred during the first 150 ms, followed by a phasic increase also lasting approximately 150 ms. Despite the prolonged period of agonist activation, Agl terminated before onset of peak velocity. A delay in onset of phasic antagonist activity corresponded to the delayed onset of peak velocity. In sharp contrast to agonist EMG activity in A and B, these short deceleration movements were always accompanied by large increases

in late agonist activity. This period of agonist activity persisted throughout the deceleratory phase and, as a result, was often coactive with the later part of the antagonist burst.

A quantitative analysis of the dependence of Agl duration on movement ratio is shown for four subjects in Fig. 32. Movement amplitude was kept constant at 40 deg and 500 ms in duration. In each subject (A - D), Agl duration was clearly dependent on the ratio of acceleration - deceleration duration. Short acceleration movements (ratio $< 0.8-1.0$) were associated with short duration Agl bursts while long acceleration movements were associated with long duration Agl bursts. Symmetrical movements (ratio = $0.8-1.0$) were associated with initial agonist bursts of intermediate durations. In all subjects (A-D), however, short duration bursts were longer than that observed during step-tracking movements. In A, for instance, Agl duration associated with short acceleration movements was approximately 150 ms while in B and C Agl duration was approximately 100 ms.

Although in some subjects a clustering of Agl durations occurred at different movement ratios (Fig. 32 B and C), it was not possible to determine from these preliminary findings if the large increase in Agl duration was the result of adding several components of agonist activity. However, in one subject, individual movements of different

Figure 32

Effects of changing movement profile on the duration of the initial agonist burst (Agl). In this figure are shown Agl durations obtained from 40 deg movements in which the ratio of acceleration duration to deceleration duration changed from approximately 0.2 to 2.2 (abscissa). Data are shown for four subjects (A - D). In each case all movements were of the same amplitude, duration and peak velocity.

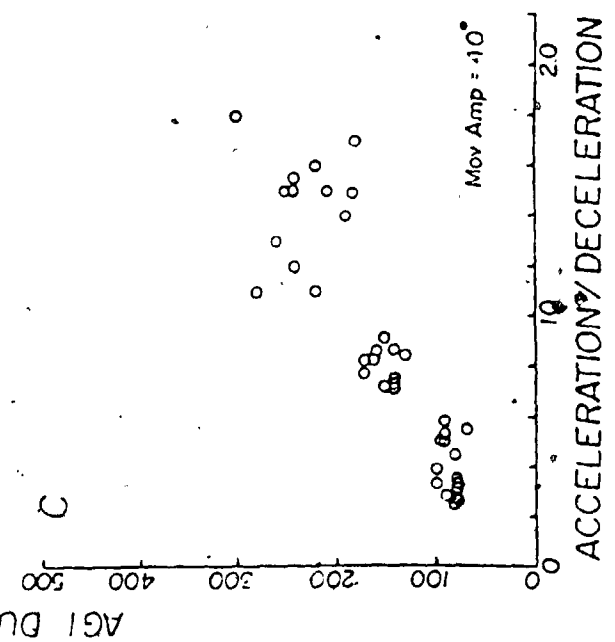
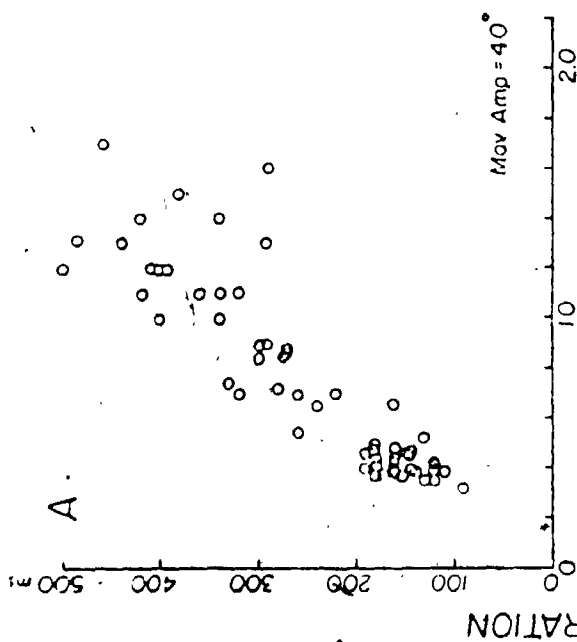
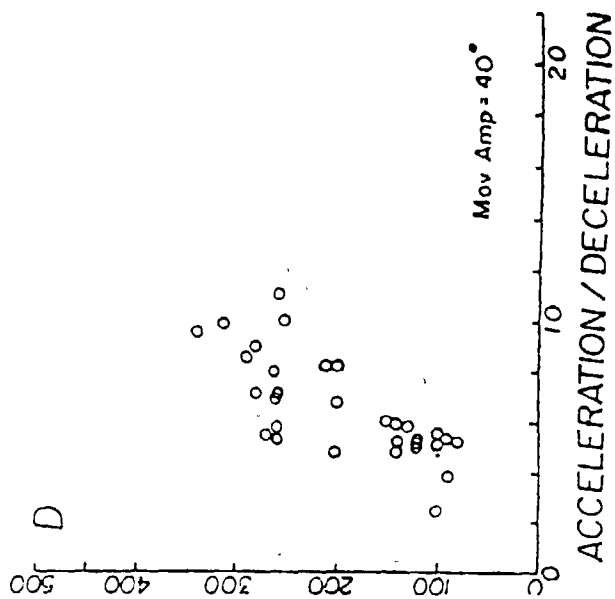
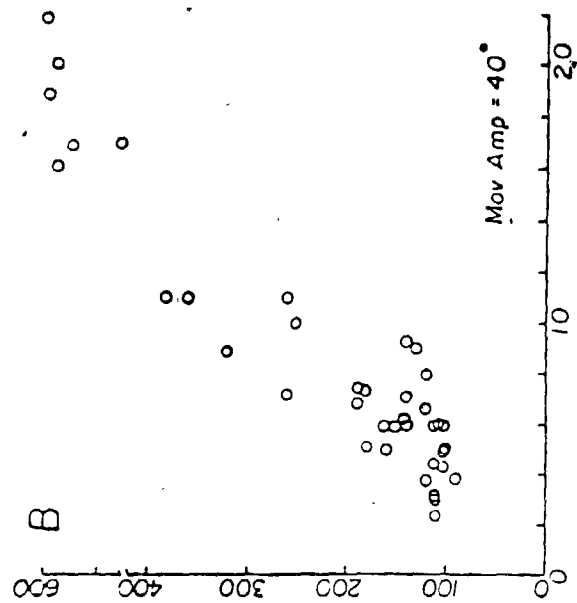

movement ratios were accompanied by multiphasic initial agonist bursts. This is shown in Fig. 33. In these movements duration and movement amplitude were kept constant at 600 ms and 40 deg. As movement ratio increased from 0.4 (top record) to 2.5 (bottom record) Agl duration increased and time of peak velocity occurred later in the movement. In this particular case, duration of Agl increased due to the addition of individual components of activity.

Figure 34 shows the shift in timing of phasic antagonist activity associated with movements of different movement acceleration - deceleration ratios. Antagonist EMG records corresponding to movement ratios ranging from 0.4 to 1.9 are shown in A (top to bottom). As velocity profiles shifted from short acceleration (0.4) to long acceleration (1.9) movements, phasic antagonist activity was progressively delayed. Onset of the antagonist burst was independent of peak velocity since peak velocity as well as movement amplitude remained constant in all movements. Rather, antagonist onset depended on the relative duration of the acceleration and deceleration phases. This is shown quantitatively for five subjects in Fig. 34B.

As mentioned earlier, late agonist activity was clearly affected by changes in the ratio of acceleration - deceleration duration. This is illustrated for one subject in Fig. 35 where movement ratios ranged from .25 (A) to 2.0 (C). Symmetrical movements (B - ratio = 1.0) show late

Figure 33

Addition of initial agonist burst (Agl) components with increasing movement ratios. In this figure are shown individual records of agonist (biceps) EMG activity associated with 40 deg flexion movements. Records were filtered at 20 Hz to illustrate the component-like structure of Agl. Vertical dashed line indicates movement onset and filled arrows indicate time of peak velocity.

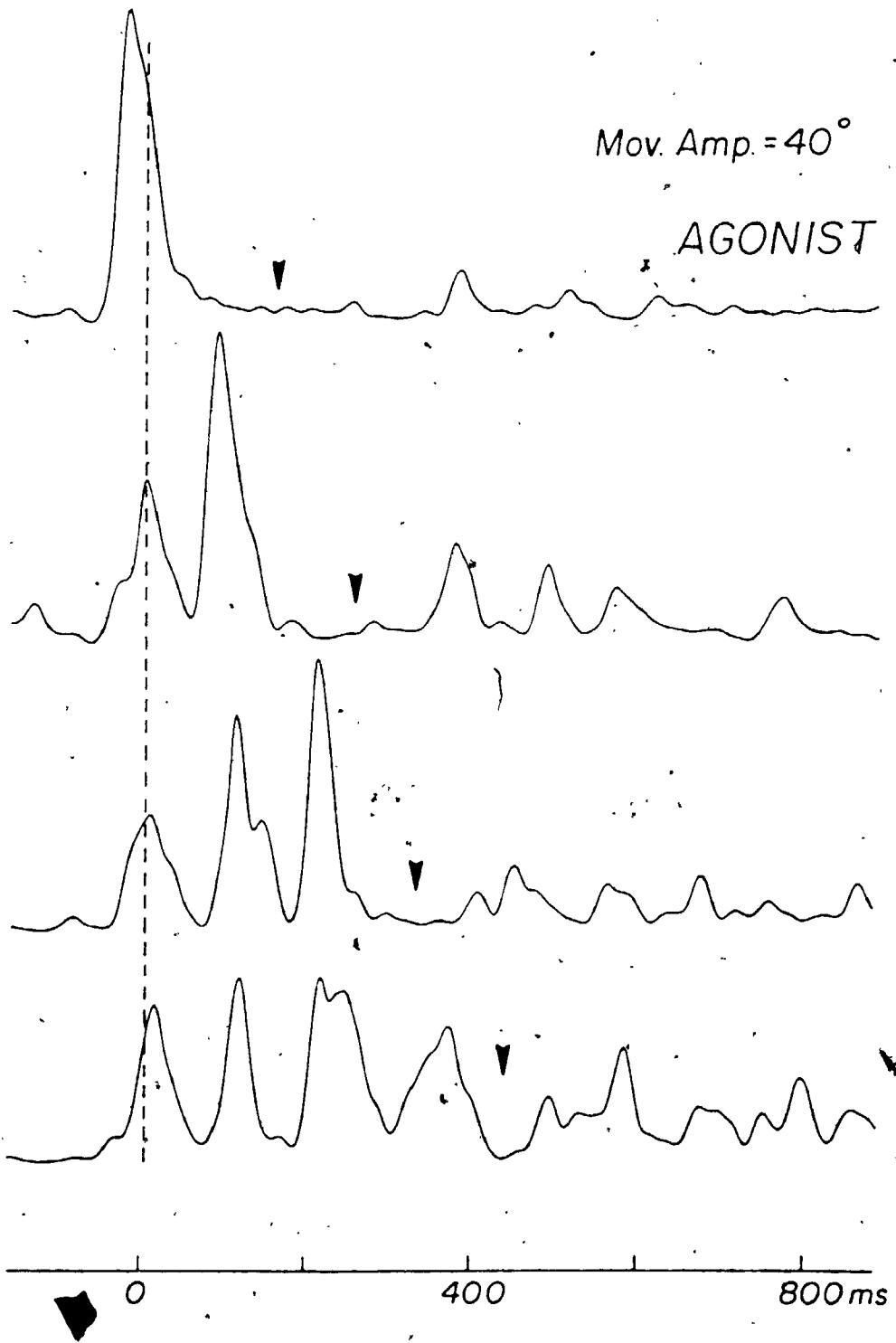
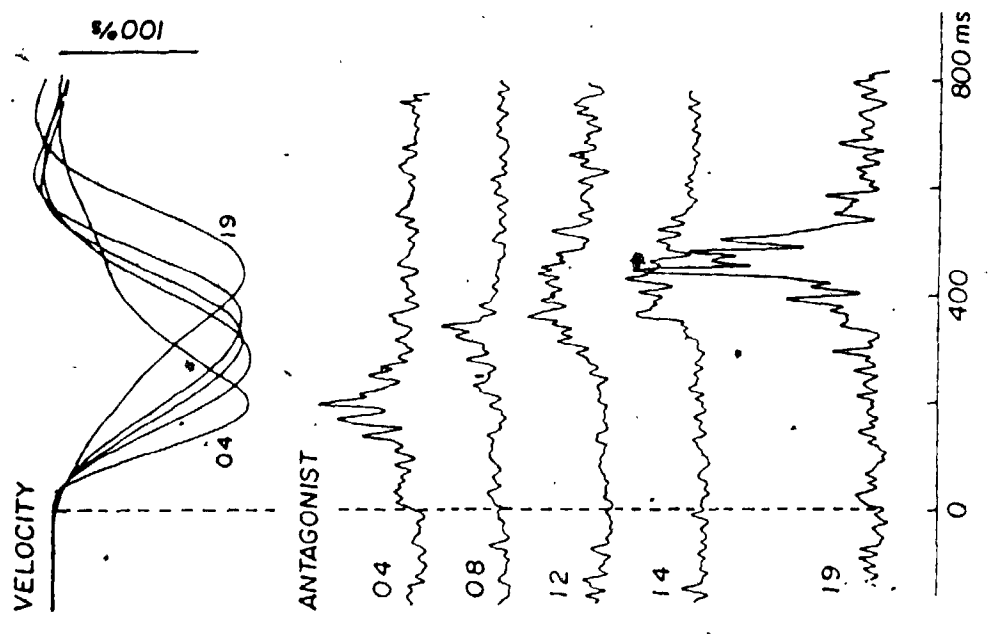

Figure 34

Effects of changing movement profile on antagonist (Antl) onset time. Averaged records ($n = 6-14$) of velocity and antagonist (biceps) EMG activity obtained from 40 deg extension movements are shown in A. The overplotted velocity records show a progressive shift from very rapid acceleration movements (movement ratio = 0.4) to very slow acceleration movements (ratio = 1.9). EMG records (top to bottom) are from movements of increasing acceleration duration. The ratio of acceleration duration to deceleration duration is given to the left of each record. In averaging movements with a ratio of > 1.0 , time of peak velocity was used to synchronize movements. All other movements were synchronized about movement onset. The onset of phasic antagonist activity (Antl) relative to movement onset (ordinate) is shown in B for four subjects at different movements ratios (abscissa).

A



B

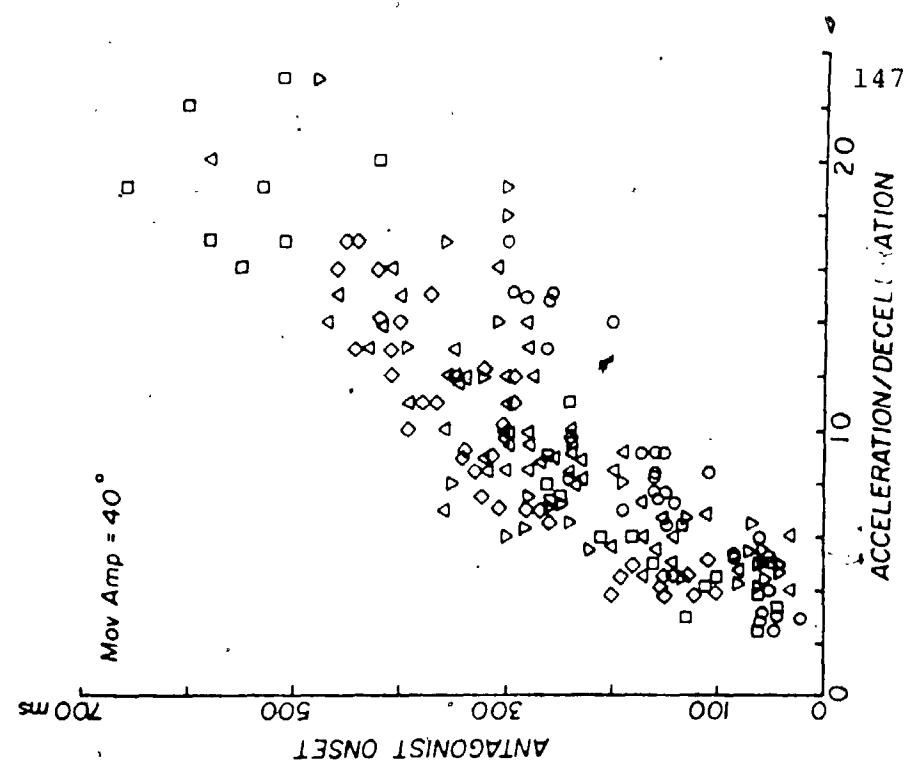

agonist activity similar to that seen in step-tracking movements. In short acceleration - long deceleration movements (A) virtually no late agonist activity followed Ag1. Long acceleration, short deceleration movements (C), however, were accompanied by a distinctly phasic second period of agonist activity.

The magnitude of late agonist activity depended strongly on the relative duration of the acceleratory and deceleratory phases. This is shown in Fig. 36. Movement amplitude remained constant at 20 deg in A and 40 deg in B and C. In each case where movement amplitude, peak velocity and movement duration remained constant the magnitude of late agonist activity increased with movement ratio. While little late agonist activity occurred in long deceleration movements (ratio < 0.5), late agonist activity increased as acceleration duration increased and deceleration duration decreased (ratio > 1.0).

Figure 35

Effects of changing movement profile on late agonist activity (Ag2). In each set of records are shown averaged (n = 12-16) of velocity and agonist (triceps) EMG activity associated with 20 deg extension movements. The upper set of records (A) corresponds to rapid acceleration movements (ratio = .25). The lower set (C) corresponds to slow acceleration movements (ratio = 2.0). Movements in which durations of acceleration and deceleration were approximately equal are shown in the middle set of records (C - ratio = 1.0). In A and B, movements were averaged about movement onset; in C, movements were averaged about the time of peak velocity. Vertical dashed line indicates movement onset. Arrows indicate time of peak velocity.

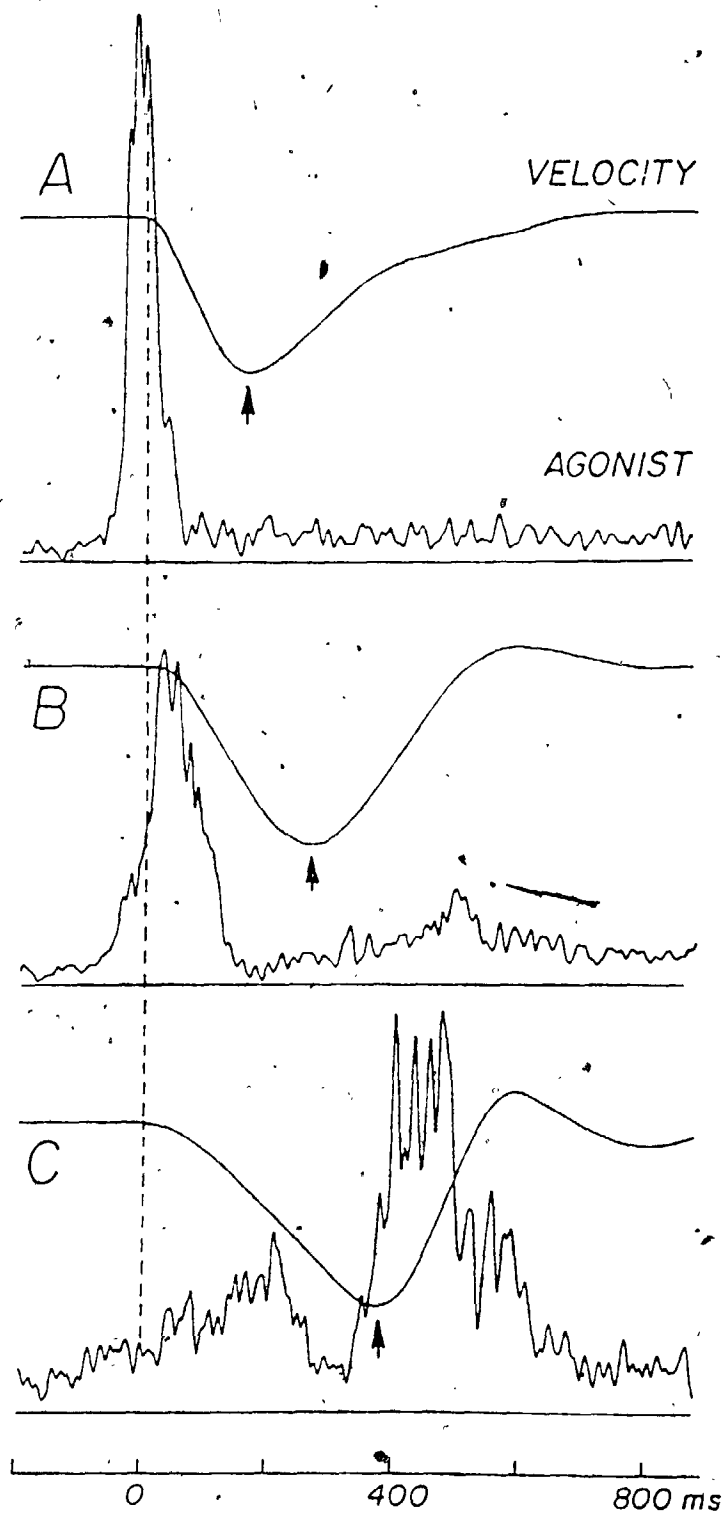
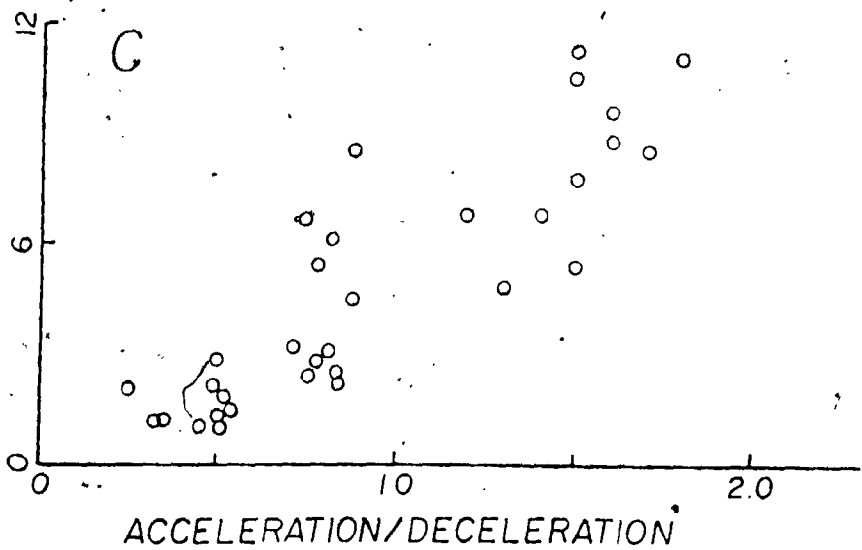
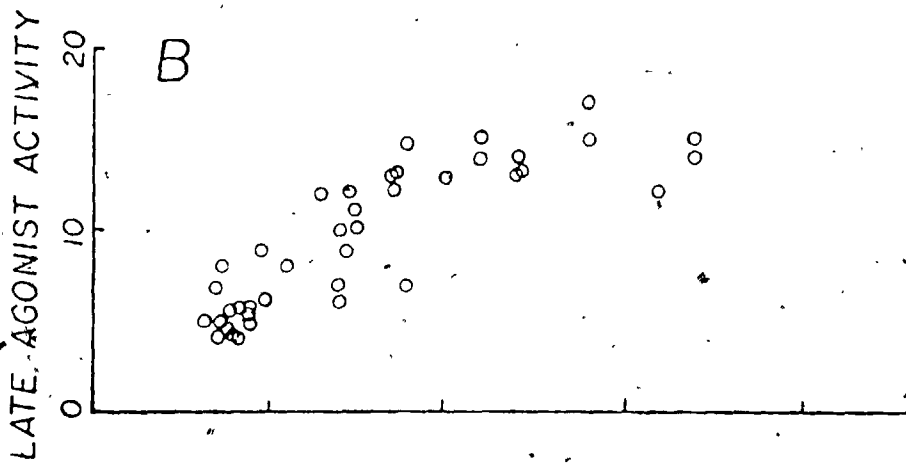
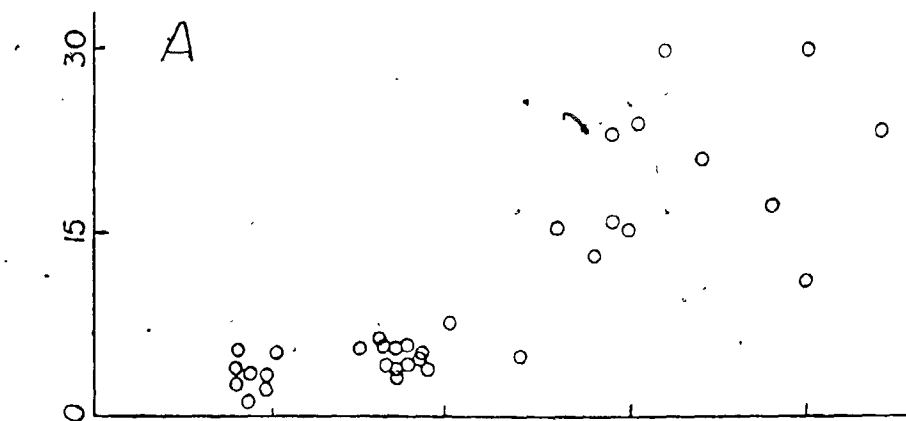

Figure 36

Dependence of late agonist activity on movement profile. The magnitude of late agonist activity (ordinate) is plotted as a function of acceleration to deceleration ratio (abscissa) for three subjects (A-C). In cases where it was difficult to determine onset of Ag2 (e.g. movement ratio < 0.8), EMG activity was integrated over the time from peak velocity to movement end. Integrated EMG values are in arbitrary units. Movement amplitude was kept constant at 20 deg in A and 40 deg in B and C.



7

DISCUSSION

I. Change in Agl Duration with Movement Amplitude

A. Results of previous studies

In the past, several investigators have claimed that the duration of the initial agonist burst (Agl) is not affected by changes in movement parameters (Hallett et al., 1975a; Hallett and Marsden, 1979; Freund and Budingen, 1978; Ghez and Vicario, 1978; Lestienne, 1979; Brown and Cooke, 1981a; Sanes and Jennings, 1984). The apparent constancy of burst duration led to the notion that movement initiation is controlled by a preprogrammed descending pulse of fixed duration and variable amplitude. An analysis of the various experimental protocols employed in these studies, however, shows that earlier conclusions drawn about Agl duration apply only to the particular experimental condition examined and do not represent a global description of how movements are initiated.

Hallett et al. (1975a) examined 10 deg movements about the elbow and concluded that the average duration of Agl, 80 ms, was "sufficiently narrow.... to be useful as standards for evaluation of patients with movement disorders." A mean burst duration of 80 ms is comparable to the present

findings but only for small amplitude movements. In addition, Hallett found considerable variability in Agl duration for the eighteen subjects examined with mean duration values ranging from 60 to 105 ms. It should be noted, however, that for nine subjects the number of measurements comprising an average duration value was restricted to five or fewer movements, and as such may not represent accurate mean values. Later studies involving thumb movements led to similar conclusions regarding Agl duration. (Hallett and Marsden, 1979). In these experiments movements of 5, 10, and 20 degrees were examined. For a given subject, burst duration was not significantly affected by differences in movement amplitude although considerable intersubject variability did occur. The fact that Hallett and Marsden restricted themselves to movements of less than 20 deg amplitude presumably explains why they found no change in Agl duration.

Freund and Budingen (1978) have suggested that, for movements of different amplitudes, movement duration is kept constant by appropriate modulation of Agl magnitude over a fixed period of time. This "speed control" theory was based, in part, on agonist EMG activity associated with rapid flexion movements of the finger. Although no EMG data was shown for these particular movements, it was stated that Agl duration remained constant across movement amplitudes. This was reportedly the case for isometric movements as

well. Despite the paucity of EMG data presented, Freund and Budingen went on to conclude that constancy of movement duration was achieved by maintaining a constant Agl burst duration.

In extending the speed control hypothesis to include programming of phasic antagonist activity, Lestienne (1979) compared 30 and 60 deg elbow movements made at different speeds and against different inertial loads. He concluded that, above a certain velocity threshold, duration of Agl was constant regardless of movement velocity and amplitude. One of the difficulties with this study is that his conclusions were based on a comparison of 30 deg flexion and 60 deg extension movements. While, in the present study, Agl associated with extension movements showed a doubling in burst duration with movement amplitude, only the lateral head of the triceps brachii muscle was examined. It is not known whether the long and medial heads behave in a similar fashion. Since Lestienne did not state which head of triceps was used, it is difficult to compare results. It is also known that synergistic muscles acting about a joint are differentially affected by changes in initial joint angle (Hof and van den Berg, 1977; Viitasalo, 1982; Darling and Hayes, 1983) and thus extension movements made from two different starting positions as in Lestienne's study may not be comparable. Finally, data obtained from two movement instructions were combined by Lestienne to construct

relationships between Agl duration and speed. Given the small number (5) of movements used in each averaged data point, it is quite possible that instruction-related differences in movement kinematics such as changes in acceleration invalidate any conclusions regarding constancy of Agl duration across movement amplitudes.

A pulse-step model developed by Ghez and co-workers to explain control of rapid movements has relied heavily on the assumption that duration of Agl remains constant for movements of different amplitudes and peak forces (Ghez and Vicario, 1978; Ghez, 1979). The pulse-step model consists of an initial phasic command or "pulse" of activity of fixed duration followed by a later tonic command responsible for maintaining final steady state force in the case of isometric movements and final limb position in the case of isotonic movements. Ghez's model arose from a detailed analysis of electromyographic and force patterns associated with rapid force tracking movements in cats (Ghez and Vicario, 1978). In this study, four major patterns were distinguished and in each case, the duration of Agl was different. In type "a" responses, there was a rapid increase in the rate of force change (dF/dt). In these movements, Agl showed only one burst of activity. This response was seen in 10-20 per cent of the total number of movements analysed. In 40-60 percent of the movements Agl consisted of additional bursts of activity which occurred

either during the rising ("b" response) or falling ("c" response) phase of dF/dt . These bursts of agonist activity were associated with separate peaks superimposed on the force record.

In both "a" (rapid force rise times) and "c" (slower force rise times) responses, movements requiring different force outputs were generated by modulating the magnitude of a fixed duration pulse of agonist activity. While Agl duration did not appear to change within a given classification (i.e. "a" versus "c" response), duration of the initial pulse was clearly modifiable by changes in the pattern of force production. Thus in this particular study, Agl duration remained constant only as long as the pattern of force production did not change. Despite this caveat, the pulse-step model in which the initial pulse is of fixed duration has received wide acceptance in the field of motor control.

In an earlier study (Brown and Cooke, 1981a) it was concluded that the duration of Agl was not affected by either movement amplitude or instruction dependent changes in movement velocity. The primary reason why a change in Agl duration was not observed in this study is due, no doubt, to the method of data analysis employed. All data used in the construction of regression curves was derived from averaged EMG records. As was illustrated in Fig. 11, not only is the fine structure of Agl obscured by averaging,

but because of variability in Agl onset relative to the synchronization point (movement onset), mean burst durations are often 10-20 per cent greater than burst durations associated with individual movements. For three of the four movement amplitudes (32, 48 and 64 deg) examined in the 1981 study, Agl duration varied by only 30 ms (130-160 ms). Given the variability which occurs with averaging it is reasonable to assume that movements made at these amplitudes were in fact initiated by long duration, two component initial agonist bursts. That small amplitude (16 deg) movements were not associated with short duration initial agonist bursts is presumably related to averaging procedures as well. If, for example, both short and long duration bursts were present in any of the pooled data included for averaging, mean burst durations would not accurately reflect burst durations associated with individual movements.

The present observation that duration of Agl increases with movement amplitude has recently been confirmed by two independent studies. Berardelli et al (1984) have found that, for rapid flexion movements about the elbow or wrist, Agl duration increased with movement amplitude. While Agl duration doubled in duration from approximately 80 ms for 15 deg elbow movements to approximately 150 ms for 105 deg movements, casual inspection of the data indicates that burst duration changed in a graded fashion. Absence of a

step-like change in burst duration in Berardelli's study is probably due, in large part, to averaging of movements across all subjects.

This method of data analysis has also been employed by Benecke et al. (1985) who have recently demonstrated changes in Agl duration with both movement amplitude and inertial loading. Twenty degree rapid flexion movements about the elbow were associated with burst durations of approximately 80 ms while for 80 deg movements, burst duration was approximately 140 ms. For intermediate movement amplitudes, changes in Agl duration appeared to be graded. Again, however, mean burst duration for each movement amplitude was obtained by pooling of averaged data from several subjects.

It is important to note that, in comparing movements made about different joints, limb inertia must be taken into account. Most of the studies examining movement initiation have focussed on movements about the finger, thumb, wrist or elbow. For each of these movements, the load which must be overcome in order to accelerate the limb is clearly different. For movements involving small loads such as movement about the thumb, changes in Agl duration may not become apparent until movement amplitude approaches the full range of joint rotation. With the exception of very large movements, modulation of Agl magnitude may be sufficient to produce increases in initial force output demanded by

increases in movement amplitude. In contrast, the present study has shown that, for movements about the elbow, only twenty per cent of the total excursion range need be utilized in order to produce a doubling of Agl duration.

B. Fine structure of Agl

The change in burst duration with movement amplitude is not graded but occurs in multiples of approximately 70 ms. This is due to the presence of a second discrete burst of agonist activity immediately following the initial period of agonist activation. Both components of activity are part of what has been considered for the last 85 years to be the "initial impulse" (Woodworth, 1899) or the initial agonist burst of the triphasic EMG pattern. The second component is completed well before the movement reaches peak velocity and before the occurrence of peak antagonist activity (Hallett et al., 1975a). Thus the second component is clearly distinct from the second burst of agonist activity which occurs during the deceleratory phase of the movement. In addition, both components of Agl originate in the same muscle. This was confirmed by intramuscular recordings from the biceps muscle which, for flexion movements about the elbow, showed a grouping of multi-unit activation into two discrete time periods corresponding to the two component pattern seen in the accompanying surface

EMG records. The appearance of individual components comprising Agl has recently been confirmed for large amplitude movements about the elbow by Benecke et al. (1985).

C. Central determination of Agl duration

Changes in burst duration with movement amplitude were clearly evident in a functionally deafferented patient. Although individual components of activity were not seen in single EMG records, the change in burst duration with movement amplitude occurred in a manner comparable to that seen in normal subjects. Small amplitude movements (6 and 12 deg) in the patient had a mean burst duration of 65 ms compared with a mean burst duration of 67 ms for pooled 10 deg movements in normal subjects. In both the deafferented patient and normal subjects, intermediate amplitude movements (36 deg - deafferented patient; 30 deg - normal subjects) had a mean burst duration of 136 ms. Of interest here is the observation that, in the deafferented patient, large amplitude movements (60 deg) were initiated by even longer duration bursts (approximately 200 ms). Whereas in normal subjects a doubling of burst duration occurred, the deafferented patient exhibited a tripling of duration as movement amplitude increased from 6 to 60 deg. Since, in normal subjects, doubling of burst duration is due to

the "recruitment" of a second component of activity, it is suggested that the change in burst duration seen in the deafferented patient is the result of recruiting one or more components each having a duration of approximately 70 ms. Previous studies have indicated that Agl duration in deafferented patients remains constant (Hallett et al., 1975a; Rothwell et al., 1982). In Hallett's study, however, only 20 deg elbow movements were examined. Similarly, for thumb movements (Rothwell et al., 1982), amplitudes were restricted to 25 deg or less and thus do not reflect the full range of movements possible about the thumb joint.

II Modulation of Agl by peripheral feedback

A. Effects of perturbations preceding movement onset

It is clear from the results of the present study that duration of Agl increases with movement amplitude. More importantly, this increase is not graded but occurs as a doubling of burst duration due to the addition of a second burst or component of phasic activity. Thus it is no longer possible to consider Agl duration to be an invariant subunit of the descending motor command. The work presented here has shown that both components of Agl can be modified by peripheral feedback. Perturbations exert a differential effect on both components - perturbations which oppose

movement (load) increase the magnitude of both components while perturbations which assist the movement (unload) increase the first component and decrease the second. It is clear that the two components do not act as a single unit since the response of the second component is not linked to the response of the first component. Thus both components comprising Agl can be considered to be independently controlled subunits and, at least for large amplitude movements, represent a double pulse rather than one large pulse as previously thought.

The duration of the individual components (pulses) appears to be relatively fixed. While overall duration of Agl could be effectively halved by large unload perturbations, the duration of the individual components was relatively constant. Thus the duration of the first component was approximately 70 ms whether or not the second component was present. In small amplitude movements where only one component was present, perturbations preceding movement resulted only in changes in Agl magnitude but not duration. Although Agl duration as a whole is not fixed, the durations of the individual components are. Given the present observations that Agl is comprised of separate components of activity, approximately 70 ms in duration, and which are independently regulated, it is suggested that these components represent the invariant subunit of the motor program. An initial burst of approximately 70 ms can be thought of as

the minimal pulse duration which the motor system can produce for initiation of movements about the elbow.

Previous studies have been inconclusive as to the extent to which Agl magnitude can be modified by afferent feedback. Garland and Angel (1971) reported that passive shortening of the agonist muscle prior to shoulder adduction did not affect Agl magnitude. Hallett et al. (1975a), however, found that extension of the elbow before onset of a fast flexion movement did result in an increase in Agl magnitude. Observations from preliminary experiments preceding the present work (Brown and Cooke, 1981b) indicated that brief perturbations applied prior to movement onset altered only the late part of Agl. The lack of any change in the first component in this earlier study may be explained by two factors. First, these movements were relatively fast and of large amplitude. Thus it may not have been possible to further increase motor unit activity during the time corresponding to the first component. Certainly, in the present study, increases in the first component with loading and unloading of fast movements were not as great as those seen in slow movements. Secondly, data averaging employed in the earlier work may have obscured slight increases in the magnitude of the first component.

It is important to note here that the responses to perturbations, either loading or unloading, were related to

the subjects' ability to "ignore" the perturbation and move according to the instruction given. For instance, movements in which the subject drifted into the target following large unloading perturbations showed only slight increases in the first component. However, the reduction in velocity and increase in movement duration of these movements clearly indicated that the subject had altered his strategy and was no longer following the instruction.

Hallett and Marsden (1979) reported that perturbations occurring prior to the onset of rapid thumb movements elicited reflex increases or decreases in Ag1 magnitude depending on perturbation direction. The present study indicates that the response to perturbations is not mediated via reflex mechanisms. The lack of apparent short or long latency responses following loading of the appropriate muscle is consistent with earlier observations (Brown and Cooke, 1981b). In this study, load perturbations applied prior to movement onset did not elicit reflex activity in the agonist muscle in the time period from 20 to 80 ms following the perturbation. This is the time when short and long latency reflex activity would be expected to occur (Hammond, 1956; Lee and Tatton, 1975; Hallett and Marsden, 1979). The effects of voluntary intent on both short and long latency reflexes has been well documented (Hammond, 1956; Hagbarth, 1967; Tatton and Lee, 1975; Thomas et al., 1977; O'Riain et al., 1979; Rothwell et al., 1982). In

these studies the presence of short and long latency reflex responses depended on how the subject was told to respond to the perturbation. It is reasonable to conclude that the instruction "do not correct for the perturbation" in the present study effectively gated long latency reflex activity. The relatively relaxed state of the subject's arm no doubt also contributed to the absence of any observable reflex activity. Similar findings have been reported by Hallett et al (1981). They showed that brief perturbations preceding voluntary contraction of the thumb flexor muscle did not elicit short or long latency responses as long as the muscle was relaxed prior to movement. While the absence of reflex responses during the time between perturbation onset and movement onset appears to conflict with observed increases in spinal excitability 30 - 100 ms prior to movement (Pierrat-Deseilligny and Lancert, 1973; Michie et al., 1976; Hayes and Clarke, 1978; Sullivan, 1980), the present findings may simply reflect instruction-dependent modulation of reflex activity.

The contribution of long loop reflexes to perturbation induced changes in Agl is confounded, however, by the observed reduction in movement response time. Although analysis of the time between perturbation onset and onset of Agl showed wide variation in response time, averaging of data revealed an overall decrease in response time compared to control values. This has recently been reported for

similar tracking tasks about the elbow (Day et al., 1983). When a brief stretch was applied to the agonist muscle during the period following an auditory cue but before movement onset, reaction time was significantly reduced. It is well known in the psychological literature that stimuli of different modalities which occur in close temporal proximity to each other will reduce reaction time. This phenomenon has generally been described as evidence for intersensory facilitation (Bernstein et al., 1969; Nicker-son, 1973; Michie et al., 1976). In the present study, the application of a kinesthetic stimulus (perturbation) soon after the presentation of the visual "go" stimulus (change in target position) may therefore have contributed to the observed reduction in reaction time. Because of the decrease in reaction time, the possibility exists that long loop reflexes were, in fact, elicited by loading but were obscured by movement-related EMG activity. This might explain the increase in the first component with loading but, of course, fails to explain increases in magnitude following unloading. However, the time relationship between Ag1 onset and movement onset in individual movements, and the timing of both components in relation to the movement profile, strongly suggest that Ag1, as defined in perturbed movements, is equivalent to the pulse of activity responsible for initiation of control movements.

What is the functional significance of these perturba-

tion induced changes in Agl? The increase in both components with loading was appropriate considering that the perturbation moved the arm away from its intended target. The increase in the first component with unloading, however, appears inappropriate since the perturbation moved the limb towards the intended final position. However, this increase was coupled with a decrease in the second component which, for large perturbations, often resulted in its complete suppression. The net result of these changes would be a large, short duration pulse of activation which would be appropriate to accelerate the limb rapidly and move it the shorter distance to the target within the same time span as in control movements.

While both Agl magnitude and duration were modulated in a functionally appropriate way in the large amplitude movements, only magnitude was modulated in small movements. Invariably, 15 deg movements had initial agonist bursts comprised of only one component which increased in magnitude following both loading and unloading. More importantly, the duration of this component was not altered despite the arm being moved toward the final target with unloading. Thus the increase in magnitude of the first component, regardless of perturbation direction, may reflect a constraint placed on the central nervous system. It may be, for example, that the initial drive to the muscle -- the first pulse or component of activity -- is constrained to increase in the

face of an altered peripheral state prior to movement and that, at least for large movements, appropriate modulation of the second component subsequently occurs. In this sense it may be possible to consider the increase in the first component following loading and unloading as a triggered response (Crago et al., 1976) but timed so as to coincide with voluntary, movement-related activity.

B. Modulation of Agl by changes in initial starting position

In general, for flexion movements about the elbow, the magnitude of Agl increases as joint angle increases and the limb assumes a more extended position. In some subjects, however, a net increase in initial agonist drive was obtained not by increasing Agl magnitude but by decreasing antagonist activation near the start of movement. Thus adjustments for changes in initial starting position are achieved by altering the relative activity of both agonist and antagonist muscles.

Under isometric conditions EMG activity is a measure of muscular force (Lippold, 1952; Bouisset and Goubel, 1968; Milner-Brown et al., 1973). If, in the isotonic situation, the driving force responsible for movement initiation is reflected by the magnitude of Agl, then position-dependent changes in the magnitude of this burst must reflect changes

in the amount of force used to set the limb in motion. One explanation for the increased agonist activity in extended positions might simply be that more agonist drive is required to overcome the increased tonic antagonist activity associated with limb extension. It has been shown that the level of tonic muscle activation in antagonistic muscles varies with joint angle (Lestienne et al., 1981; Cooke and Brown, 1983). If, for example, the forearm is held in progressively more extended positions, triceps activity increases relative to biceps activity. Conversely, as the arm is held in more flexed positions, biceps activity increases while triceps decreases. The changes in tonic EMG levels with joint angle reflect the force required to hold the limb in different positions in the face of changing elastic force produced by muscle stretch. Thus as the limb is held in progressively more flexed positions, the elastic force exerted by the more stretched triceps increases. In order to counterbalance this and hold the limb stationary, an increased force must be produced by the biceps.

It is unlikely that increases in agonist activity resulted solely from increases in tonic antagonist activation. First, increases in joint angle were accompanied by large increases in phasic agonist drive compared to the much smaller change in tonic antagonist activity responsible for holding the limb in an extended position. Second, a reduction in tonic antagonist activity prior to and coinci-

dent with Agl was often seen as the limb become more extended. Since tonic antagonist drive exerts a force opposing movement, a reduction in this drive would actually augment the force produced by the agonist. Third, reducing the level of tonic antagonist excitation by changing the passive equilibrium position did not prevent the position-dependent increases in agonist burst magnitude. This increase, however, was not as great as that observed when tonic activation of the antagonist muscle was required to hold the limb in an extended position, suggesting that the increase in Agl magnitude is partly related to position-dependent changes in tonic antagonist activity.

It is also possible that increased agonist activity associated with different starting positions was related to changes in the length-tension properties of the biceps muscle. The amount of force which a muscle can produce will depend on the length of the muscle (Ralston et al., 1947; Gordon et al., 1966). For muscle lengths less than resting length, this relationship is primarily due to limitations imposed on cross-bridge formation while at longer muscle lengths, changes in passive elastic forces contribute significantly to the total force the muscle produces. If the passive equilibrium position of the arm is equivalent to the resting length of those muscles acting about the elbow, then it would be expected that this position would represent the highest point on the length-tension curve.

Consequently, at this position the muscle would produce the greatest isometric force for a given level of muscle activation. Assuming that movement initiation must take into account the inherent ability of the muscle to produce a given force at a particular length, one might expect movements made from the biceps equilibrium position to be associated with a smaller Agl. In the present study, minimal agonist burst magnitudes occurred at approximately 75-85 deg. Since the passive equilibrium position of the arm is approximately 80-90 deg (Lestienne et al., 1981; Cooke and Brown, 1983), it may be that at this position minimal agonist activity does reflect maximal force output. It is difficult, however, to explain the large increases in agonist burst magnitude at increased joint angles on the basis of decreased tension production at longer muscle lengths. With prior stretching of the muscle the tension developed will reflect not only the active tension due to cross-bridge formation but also a passive component due to stretch of the parallel elastic structures. This additive effect results in a flattening of the length-tension curve.

A more likely explanation for the increase in Agl magnitude is related to the loss of "mechanical advantage" as joint angle is increased. The maximum torque which can be produced by contracting muscle will depend on both the muscle moment arm and total muscle force. The total force

applied along the biceps can be resolved into two component vectors: one which acts along the length of the forearm contributing to elbow stabilization and one perpendicular to the forearm which is responsible for movement about the elbow. Anatomical studies have shown that the actual moment arm of biceps in humans is twice as large in midrange positions compared to fully extended positions (Amis et al., 1979; An et al., 1981). Several studies have illustrated the combined effects of changes in both muscle length and moment arm on tension developed by the contracting muscle. For isometric biceps contraction, it has been shown that torque is minimal in flexed and extended positions and is maximal near the midrange of movement (Doss and Karpovich, 1965; Singh and Karpovich, 1966; Komi, 1973). Similar relationships have been found to exist for knee extension movements (Moritz et al., 1973). Since both rotatory force as well as biceps moment arm decreases in magnitude as elbow angle increases, a greater agonist drive to the muscle is therefore required in the more extended positions to compensate for the decrease in torque.

Although changes in the initial drive to the agonist muscle was the most prominent feature following changes in joint angle, it is important to realize that compensation for altered limb mechanics can be effected by modulation of either the agonist or antagonist muscle or both. While increasing agonist drive is perhaps, the most obvious way in

increase force and thus compensate for a loss in mechanical advantage, it is also possible to increase force by maintaining a constant phasic agonist drive and, at the same time, decreasing antagonist activity. Thus it is the relative activities of opposing muscles which must be adjusted so as to produce a driving force appropriate for the changes in mechanical conditions. In static positioning tasks, for example, changes in the relative activity of opposing muscles acting about the elbow are responsible for holding the arm in different positions (Lestienne et al., 1981). In the case of movements made from different positions, compensation for angle-dependent changes in limb mechanics is clearly goal-directed. Given the instruction to "make movements the same way", subjects were able to closely match movement trajectories once a particular pattern of EMG modulation had been adopted. It is possible then to consider movement trajectory as the actual programmed variable underlying these particular movements (cf. Cooke, 1980a,b). Thus EMG modulation, especially of phasic agonist drive, appears to be more concerned with moving the limb along a predetermined path rather than compensating for angle-dependent force changes per se.

.III. Relationship between phasic EMG drive and movement trajectory

The results discussed so far have shown that the number of components comprising Agl depends on movement amplitude. However, other experiments indicate that Agl duration does not depend on movement amplitude but rather on the relative durations of the acceleration and deceleration phases of the movement.

In movements with the same amplitude, peak velocity and movement duration, changes in the ratio of acceleration duration to deceleration duration (movement ratio) produced movement profiles of varying degrees of asymmetry. Individual movements with a symmetrical profile (ratio = 1.0) showed a multi-component structure of Agl similar to those seen in step-tracking movements (cf. Fig. 33). Short acceleration movements (ratio < 1.0), however, were initiated by initial agonist bursts having only one component despite the fact that movement amplitude, duration and peak velocity did not change. Long acceleration movements (ratio > 1.0) were associated with prolonged agonist activity. This often appeared as a combination of tonic and phasic changes in the initial agonist drive.

Although the fine structure of Agl as well as its temporal relationship to movement parameters such as

movement onset were qualitatively similar in both tracking paradigms, the duration of Agl associated with symmetrical and short acceleration movement profiles was greater compared to Agl durations associated with step-tracking movements. Minimal base duration increased from approximately 70 ms in step-tracking movements to approximately 100 ms in phase-plane tracking. Despite this increase in pulse duration, several subjects (cf. Fig 32 A,C) exhibited a step-like change in Agl duration with movement ratio. Thus for movements about a given joint, it may be possible to change the minimal pulse duration depending on the task requirements.

Onset of phasic antagonist activity was also affected by changes in movement profile. Regardless of movement ratio (and consequently Agl duration) onset of the antagonist burst closely followed the termination of Agl. This may suggest that onset of antagonist activity is determined primarily by Agl duration. The change in antagonist onset in movements of the same peak velocity suggests that timing of phasic antagonist activity is not determined by movement speed as has been suggested by other investigators (Lestienne, 1979; Marsden et al., 1983) but rather by the relative durations of acceleration and deceleration.

The effects of changes in movement profile were perhaps most dramatic with respect to the second agonist burst. In symmetrical, step-tracking movements, late agonist activity

is often poorly defined and consequently has not been subject to rigorous analysis. This burst of agonist activity is generally thought to be characteristic of relatively fast movements where it acts to stabilize the limb following movement termination (Ghez and Martin, 1982; Meinck et al., 1984). The present results indicate, however, that movement speed is not the critical factor in determining the presence and magnitude of the second agonist burst. Virtually no late agonist activity was observed in short acceleration movements. In contrast, long acceleration movements of the same peak velocity were consistently characterized by large phasic bursts of agonist activity beginning after the time of peak velocity and lasting throughout the deceleratory phase. This suggests that the second agonist burst, as seen with the timing of the antagonist burst, is not related to movement amplitude or speed but rather to the characteristics of the movement profile. There was often a partial overlap between late agonist activity and the antagonist burst. This coactivation of both agonist and antagonist muscles would increase joint stiffness and thereby decelerate the limb more rapidly. This would explain the complete lack of late agonist activity in short acceleration - long deceleration movements.

Previously, all studies of movement-related EMG activity have been concerned with step-tracking movements which are

ments, the target bar display was turned off before initiation of each flexion movement. Mean durations of Agl were 60 ± 22 ms. for 6.deg movements.

II. Effects of peripheral feedback on the initial agonist burst

The results in the preceding section show that, for large amplitude movements, Agl consists of individual subunits or components of activity. Furthermore, the change in Agl duration resulting from the presence of one or more components does not depend on information arising from the periphery. To determine if these centrally generated components could be altered by peripheral feedback, two sets of experiments were performed. In the first, brief perturbations were applied immediately prior to the onset of movement. In the second, the effects of changes in initial starting position on Agl were examined.

A. Effects of perturbations preceding movement on Agl

1. Changes in Agl magnitude and duration

Brief (50 ms) torque pulses which either loaded or

3

OF/DE

3

MICROCOPY RESOLUTION TEST CHART
NBS 1010a
ANSI and ISO TEST CHART No. 21

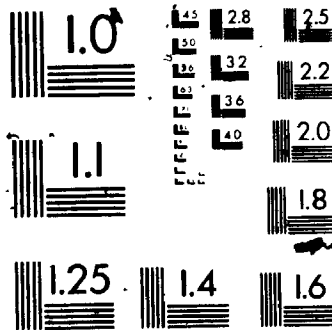

characterized by symmetrical movement profiles. The results presented here, however, illustrate that the timing and intensity of the various components of the triphasic EMG pattern can be independently controlled by changes in the relative durations of the acceleratory and deceleratory phases of the movement. Clearly, the planning by the central nervous system of a reciprocally organized pattern of agonist and antagonist muscle activation will depend on how the movement is to be made.

IV Programming of the initial agonist burst

The view has been widely held that, in order to produce movements of different amplitudes and speeds, the central nervous system is constrained to modulate the magnitude of Agl over a fixed period of time. The present studies have shown this not to be so. The central nervous system has, in fact, two mechanisms by which the acceleratory force produced by the contracting muscle can be varied - namely, Agl magnitude and duration. Although the change in burst duration is centrally determined, it is clear from the results of perturbation experiments that Agl is accessible to modification prior to movement initiation.

Of particular interest is the finding that changes in Agl duration are effected through the "recruitment" of

individual subunits or pulses of activity. The duration of these subunits appeared to be relatively immune to peripheral feedback. This suggests that these separate pulses of activity may, in fact, represent a programmed component of the descending command underlying movement initiation. One can only speculate as to the functional significance of a pulse duration of approximately 70 ms in duration. It is possible, perhaps, that activation of the motoneuronal pool for this period of time may represent the most efficient means of closely controlling muscle force, possibly by taking advantage of summation properties of a particular population of slow and fast twitch motor units.

The question arises as to where these components or pulses of initial agonist activity are generated within the central nervous system. To date, there have been no published reports of neurons in primate motor cortex which exhibit a biphasic discharge pattern prior to movement initiation. However, area 4 neurons which are activated prior to rapid elbow movements have been found to exhibit fractionation of the initial cortical burst (Jennings, personal communication). Given its role in regulating the timing of phasic, movement-related muscle activity, it is tempting to speculate that the number of components comprising Ag1 are determined by the cerebellum. This would involve the generation of one or more components of agonist activity depending on the characteristics of the intended

movement. The response of individual components to unexpected perturbations suggests that such modulation may be under cerebellar control. The cerebellum receives not only a copy of the descending motor command but also receives continuous information from peripheral receptors including muscle spindles. This allows the cerebellum to act as a "comparator" of central and peripheral information (Oscarsson, 1973; Allen and Tsukahara, 1974) and, in the particular case of movement initiation, would permit corrective updating of Ag1 prior to activation of the agonist muscle.

SUMMARY

1. The initial burst of agonist EMG activity associated with visually-guided, step-tracking movements about the elbow were studied. Experiments were conducted to examine the effects of movement amplitude and peripheral feedback on initial agonist burst duration and magnitude. Experiments were performed on a total of fifteen normal subjects and one deafferented patient.

2. Duration of the initial agonist burst was greater for large (40-50 deg) than for small (5-20) amplitude movements. Burst duration was not continuously graded but was either short (approximately 70 ms) for small amplitude movements or long (approximately 140 ms) for large amplitude movements. Movements of intermediate amplitudes (20-30 deg) were made with either short or long duration initial agonist bursts. This pattern of change in burst duration was seen in both fast and slow movements and in all eight subjects examined.

3. The increase in initial agonist burst duration associated with large amplitude movements was produced by the appearance of a second peak or component of agonist activity. Both components were approximately the same duration and occurred before movement peak velocity was reached.

Intramuscular recordings from biceps brachii showed that both components of the initial agonist burst associated with flexion movements originated from the same muscle.

4. The magnitude of the first component increased with movement amplitude. When the second component appeared at intermediate to large movement amplitudes, the magnitude of both components increased in parallel with further increases in movement amplitude.

5. These observations show that, in contrast to previously held views, the central nervous system has a second mechanism for altering the initial drive to the agonist muscle. In addition to modulating initial agonist burst magnitude, burst duration is also modulated by the generation of a second component or pulse of agonist activity at the start of movement.

6. To determine if afferent feedback was required for the modulation of initial agonist burst duration, similar experiments were performed in a deafferented patient. The patient had been functionally deafferented for five years, having no touch, vibration, pressure or kinesthetic sensation nor any tendon reflexes in the four limbs. Pain and temperature sensation were intact and motor fibres were unaffected. For flexion movements about the elbow, initial

agonist burst duration increased with movement amplitude. Burst duration was approximately 65 ms in small movements (6-12 deg), and increased to 136 ms in intermediate movements (36 deg) and 200 ms in large (54-60 deg) movements. Similar changes in burst duration with movement amplitude were seen when non-visually-guided movements were made.

7. It is concluded that changes in initial agonist burst duration are centrally determined and do not depend on information arising from the periphery.

8. In a second set of experiments, the effect of unexpected peripheral disturbances in modulating the initial agonist burst was investigated. Brief (50 ms) torque pulse perturbations were randomly applied immediately prior to movement onset. Perturbations either opposed (load) or assisted (unload) the forthcoming movement.

9. In 30 deg movements, load perturbations caused both components of the initial agonist burst to increase in magnitude. In contrast, unloading increased the magnitude of the first component but decreased the magnitude of the second. Changes in component magnitude were graded with the size of the perturbation, large perturbations causing a greater change in component magnitude than small perturbations. These effects were observed in both fast and slow

movements and in all five subjects examined.

10. Durations of the individual components were relatively unaffected by either load or unload perturbations. In general, however, movement response time (onset of the initial agonist burst relative to the signal to move) was decreased in perturbed movements compared to control movements.

11. The effects of perturbations on the initial agonist burst provided additional evidence that the initial agonist burst is comprised of individual subunits of activity which can be independently modulated by the central nervous system prior to movement.

12. In a third set of experiments, the effects of changes in initial elbow position on movement-related EMG activity were examined. Five subjects made relatively slow, step-tracking movements from starting positions ranging from 65 to 125 deg (joint angle).

13. In general, the magnitude of the initial agonist burst associated with flexion movements increased as starting position became more extended. This increase in initial agonist burst magnitude occurred in both small, one-component (10 deg) and large, two-component (40 deg) movements.

14. In one subject, little change in initial agonist burst magnitude was observed across different starting positions. However, movements made by this subject were accompanied by greater antagonist inhibition occurring prior to movement onset as compared to other subjects.

15. Movement (phase-plane) trajectories associated with different starting positions were not altered despite large differences in initial agonist burst magnitude. It is therefore hypothesized that the change in EMG activity associated with movement initiation (either an increase in agonist activity or a decrease in antagonist activity, or both) compensate for angle-dependent changes in limb mechanical properties so as to maintain a prelearned movement trajectory.

16. Experiments utilizing a phase-plane tracking paradigm were conducted to examine the relationship between phasic EMG activity and movement trajectory. In these experiments, movement amplitude, peak velocity and movement duration were kept constant while altering the ratio of acceleration duration to deceleration duration.

17. Changes in the ratio of acceleration to deceleration duration affected the duration of the initial agonist burst,

the onset of phasic antagonist activity and the magnitude of late agonist activity. As movement profiles progressively shifted from short acceleration, long deceleration movements to long acceleration, short deceleration movements, the duration of the initial agonist burst increased. In addition, phasic antagonist activity was delayed relative to movement onset. Pronounced increases in the magnitude of late agonist activity were associated with long acceleration, short deceleration movements.

18. These findings suggest that the timing and magnitude of movement-related EMG activity are not related to a single movement parameter such as amplitude or speed but rather to the profile of the intended movement.

APPENDIX A

NOTE ADDED UPON FINAL REVISION

During the course of this work and its examination within the University of Western Ontario, there has been considerable discussion about the statistical treatment of data. The reader is referred to recent papers (Cooke and Brown, 1985b; Munhall and Kelso, 1985) for an analysis of the different points of view held on this subject.

REFERENCES

- Abend, W., Bizzi, E. and Morasso, P. (1982) Human arm trajectory formation. *Brain*, 105: 331-348.
- Adam, J.A. (1971) A closed-loop theory of motor learning. *J. Mot. Behav.*, 3: 111-149.
- Allen, G.I. and Tsukahara, N. (1972) Cerebrocerebellar communication systems. *Physiol. Rev.*, 54: 957-1006.
- Alston, W., Angel, R.W., Fink, F.S. and Hofmann, W.W. (1967) Motor activity following the silent period in human muscle. *J. Physiol.*, 190: 189-202.
- Amis, A.A., Dowson, D. and Wright, V. (1979) Muscle strengths and musculo-skeletal geometry of the upper limb. *Eng. Med.*, 8: 41-48.
- An, K.N., Hui, F.C., Morrey, B.F., Linschied, R.L. and Chao, E.Y. (1981) Muscles across the elbow joint: A biomechanical analysis. *J. Biomech.*, 14: 659-669.
- Angel, R.W. (1974) Electromyography during voluntary movement: The two burst pattern. *Electroenceph. clin. Neurophysiol.*, 36: 493-498.
- Angel, R.W. (1977) Antagonist muscle activity during rapid arm movements: Central versus proprioceptive influences. *J. Neurol. Neurosurg. Psychiat.*, 40: 683-686.
- Angel, R.W., Eppler, W. and Iannone, A. (1965) Silent period produced by unloading of muscle during voluntary contraction. *J. Physiol.*, 180: 864-870.
- Annett, J., Golby, C.W. and Kay, H. (1958) The measurement of elements in an assembly task - the information output of the human motor system. *Quart. J. Exp. Psychol.*, 10: 1-11.
- Beggs, W.D.A. and Howarth, C.I. (1972) The movement of the hand towards a target. *Quart. J. Exp. Psychol.*, 24: 448-453.
- Benecke, R., Meinck, H.-M. and Conrad, B. (1985) Rapid goal-directed flexion movements: limitation of the speed control system due to neural constraints. *Exp. Brain Res.*, 59: 470-477.
- Berardelli, A., Rothwell, J.C., Day, B.L., Kachi, T. and Marsden, C.D. (1984) Duration of the first agonist EMG burst in ballistic arm movements. *Brain Res.*, 304: 183-187.

- * Bernstein, I.M., Clarke, M.H. and Edelman, B.A. (1969) Effects of an auditory signal on visual reaction time. *J. Exp. Psychol.*, 80: 567-569.
- Bizzi, E., Polit, A. and Morasso, P. (1976) Mechanisms underlying achievement of final head position. *J. Neurophysiol.*, 39: 435-444.
- Bizzi, E., Accornero, N., Chapple, W. and Hogan, N. (1984) Posture control and trajectory formation during arm movement. *J. Neurosci.*, 4: 2738-2744.
- Bouisset, S. and Goubel, F. (1968) Interdependence of relations between integrated EMG and diverse biomechanical quantities in normal voluntary movements. *Electromyography suppl.*, 8: 151-162.
- Brown, S.H. and Cooke, J.D. (1981a) Amplitude- and instruction-dependent modulation of movement-related electromyogram activity in humans. *J. Physiol.*, 316: 97-107.
- Brown, S.H. and Cooke, J.D. (1981b) Responses to force perturbations preceding voluntary human arm movements. *Brain Res.*, 220: 350-355.
- Burton, J.E. and Onoda, N. (1977) Interpositus neuron discharge in relation to a voluntary movement. *Brain Res.*, 121: 167-172.
- Burton, J.E. and Onoda, N. (1978) Dependence of the activity of interpositus and red nucleus neurons on sensory input data generated by movement. *Brain Res.*, 152: 41-63.
- Cooke, J.D. (1980a) The role of stretch reflexes during active movements. *Brain Res.*, 181: 493-497.
- Cooke, J.D. (1980b). The organization of simple skilled movements. In: *Tutorials in Motor Behaviour*. Stelmach, G. and Requin, J. (eds.). Amsterdam: North Holland Publ., 199-212.
- Cooke, J.D. and Brown, S.H. (1983) EMG activity and arm movement trajectories. *Soc. Neurosci. Abstr.*, 9: 1034.
- Cooke, J.D. and Brown, S.H. (1985a) Transition from "slow" to "fast" movements: superposition of motor programs. *Soc. Neurosci. Abstr.*, 11: 72.
- Cooke, J.D. and Brown, S.H. (1985b) Science and statistics in motor physiology. *J. Mot. Behav.*, 17: 489-492.
- Cooke, J.D. and Brown, S.H. (1986) Phase plane trajectory tracking: a new way of shaping movements. *Brain Res. Bull.* (in

press).

- Cooke, J.D. and Spencer, S. (1984) Central and peripheral modification of the unloading reflex in man. Soc. Neurosci. Abstr., 10: 330.
- Crago, R.E., Houk, J.D. and Hasan, Z. (1976) Regulatory actions of the human stretch reflex. J. Neurophysiol., 39: 925-935.
- Crossman, E.R.F.W. and Goodeve, P.J. (1963) Feedback control of hand-movement and Fitts' Law. Paper presented at the meeting of the Exp. Psychol. Soc. (1963), published in Quart. J. Exp. Psychol., (1983) 35A: 251-278.
- Crutcher, M.D. and DeLong, M.R. (1984) Single cell studies of the primate putamen. II. Relations to direction of movements and pattern of muscular activity. Exp. Brain Res., 52: 244-258.
- Darling, W.G. and Hayes, K.C. (1983) Human servo responses to load disturbances in fatigued muscle. Brain Res., 267: 345-351.
- Day, B.L. and Marsden, C.D. (1982) Accurate repositioning of the human thumb against unpredictable dynamic loads is dependent upon peripheral feedback. J. Physiol., 237: 393-407.
- Day, B.L., Rothwell, J.C. and Marsden, C.D. (1983) Interaction between the long-latency stretch reflex and voluntary electromyographic activity prior to a rapid voluntary motor reaction. Brain Res., 270: 55-62.
- Desmedt, J.E. and Godaux, E. (1978) Ballistic skilled movements-load compensation and patterning of the motor commands. In: Cerebral Motor Control in Man: Long Loop Mechanisms, Vol 4, Desmedt, J.E. (ed.). Basel: Karger, 21-55.
- Doss, K.N. and Karpovich, P.V. (1965) A comparison of concentric, eccentric and isometric strengths of elbow flexors. J. Appl. Physiol., 20: 351-353.
- Enoka, R.M. (1983) Muscular control of a learned movement: the speed control system hypothesis. Exp. Brain Res., 51: 135-145.
- Eccles, J.C. (1973) The understanding of the brain. New York: McGraw-Hill.
- Feldman, A.G. (1966) Functional tuning of the nervous system with control of movement in maintenance of a steady

- posture. II. Controllable parameters of the muscle. *Biophysics*, 11: 565-578.
- Fel'dman, A.G. (1974a) Change in the length of the muscle as a consequence of a shift in equilibrium in the muscle-load system. *Biophysics*, 19: 544-548.
- Fel'dman, A.G. (1974b) Control of the length of a muscle. *Biophysics*, 19: 766-771.
- Flament, D., Hore, J. and Vilis, T. (1984) Braking of fast and accurate elbow flexions in the monkey. *J. Physiol.*, 349: 195-203.
- Flowers, K.A. (1975) Ballistic and corrective movements in an aiming task: intention tremor and Parkinsonian movement disorders compared. *Neurol.*, 25: 413-421.
- Flowers, K.A. (1976) Visual 'closed-loop' and 'open-loop' characteristics of voluntary movement in patients with parkinsonism and intention tremor. *Brain*, 99: 269-310.
- Forget, R. (1986) Perte des afferences sensorielles et fonction motrice chez l'homme. PhD. Thesis. Univ. of Montreal.
- Forget, R. and Lamarre, Y. (1983) Antagonist muscle activity during rapid flexion of the forearm in a functionally deafferented human subject. *Soc. Neurosci. Abstr.*, 9: 630.
- Freund, H.-J. and Buidingen, H.J. (1978) The relationships between speed and amplitude of the fastest voluntary contractions of human arm muscles. *Exp. Br. Res.* 31: 1-12.
- Gatland, H. and Angel, R.W. (1971) Spinal and supraspinal factors in voluntary movement. *Exp. Neurol.*, 33: 343-350.
- Georgopoulos, A.P., Kalaska, J.F. and Massey, J.T. (1981) Spatial trajectories and reaction times of aimed movements: effects of practice, uncertainty and change of target location. *J. Neurophysiol.*, 46: 725-743.
- Georgopoulos, A.P., DeLong, M.R. and Crutcher, M.D. (1983) Relations between parameters of step-tracking movements and single cell discharge in the globus pallidus and subthalamic nucleus of the behaving monkey. *J. Neurosci.*, 3: 1586-1598.
- Ghez, C. (1979) Contributions of central programs to rapid limb

- movement in the cat. In: Integration in the Nervous System; Asanuma, H. and Wilson, V.J. (eds.). Tokyo: Igaku--Shoin Ltd., 305-320.
- Ghez, C. and Martin, J.H. (1982) The control of rapid limb movement in the cat. III Agonist - antagonist coupling. *Exp. Br. Res.*, 45: 115-125.
- Ghez, C. and Vicario, D. (1978) The control of rapid limb movement in the cat. II Scaling of isometric force adjustments. *Exp. Brain Res.*, 33: 191-202.
- Gielen, C.C.A.M., van den Heuvel, P.J.M. and Denier van der Gon, J.J. (1984) Modification of muscle activation pattern during fast goal-directed arm movements. *J. Mot. Behav.*, 16: 2-19.
- Gordon, J. and Ghez, C. (1984) EMG patterns in antagonist muscles during isometric contraction in man: relations to response dynamics. *Exp. Brain Res.*, 55: 167-171.
- Gordon, A.M., Huxley, A.F. and Julian, J.F. (1966) The variation in isometric tension and sarcomere length in vertebrate muscle fibres. *J. Physiol.*, 184: 170-192.
- Gottlieb, G.L. and Agarwal, G.C. (1980) Response to sudden torques about the ankle in man. II. postmyotatic reaction. *J. Neurophysiol.*, 43: 86-101.
- Hagbarth, K.-E. (1967) EMG studies of stretch reflex in man. in *Recent Advances in Clinical Neurophysiology*, suppl. 25. L.Widen (ed). Amsterdam: Elsevier. 74-79.
- Hallett, M. and Khoshbini, S. (1980) A physiological mechanism of bradykinesia. *Brain*, 103: 301-314.
- Hallett, M. and Marsden, C.D. (1979) Ballistic flexion movements of the human thumb. *J. Physiol.*, 294: 33-50.
- Hallett, M., Bielański, M. and Marsden, C.D. (1981) Behavior of the long-latency stretch reflex prior to voluntary movement. *Brain Res.*, 219: 178-185.
- Hallett, M., Shahani, B.T. and Young, R.R. (1975a) EMG analysis of stereotyped voluntary movements in man. *J. Neurol. Neurosurg. and Psychiat.*, 38: 1154-1162.
- Hallett, M., Shahani, B.T. and Young, R.R. (1975b) EMG analysis of patients with cerebellar deficits. *J. Neurol. Neurosurg. and Psychiat.*, 38: 1163-1169.
- Hammond, P.H. (1956) The influence of prior instruction to the

subject on an apparently involuntary neuromuscular response. *J. Physiol.*, 132: 17p.

Hayes, K.C. and Clarke, A.M. (1978) Facilitation of late reflexes in humans during the preparatory period of voluntary movement. *Brain Res.*, 153: 176-182.

Hikosaka, O. and Wurtz, R.H. (1983) Visual and oculomotor functions of monkey substantia nigra pars reticulata. III. Memory contingent visual and saccade responses. *J. Neurophysiol.*, 49: 1268-1284.

Hof, A.L. and van den Berg, J. (1977) Linearity between the weighted sums of the EMGs of the human triceps surae and the total torque. *J. Biomech.*, 10: 529-539.

Hogan, N. (1984) An organizing principle for a class of voluntary movements. *J. Neurosci.*, 4: 2745-2754.

Holmes, G. (1922) Clinical symptoms of cerebellar disease and their interpretation. The Croonian lectures II. *Lancet* 2: 1231-1237.

Hopf, H.C., Lowitzsch, K. and Schlegel, H.J. (1973) Central versus proprioceptive influences in brisk voluntary movements. In: *Human Reflexes, Pathophysiology of Motor Systems, Methodology of Human Reflexes*. Desmedt, J.E. (ed.). Basel: Karger. 273-276.

Hore, J. and Vilis, T. (1980) Arm movement performance during reversible basal ganglia lesions in the monkey. *Exp. Brain Res.*, 39: 217-228.

Ito, M. (1970) Neurophysiological aspects of the cerebellar motor control system. *Int. J. Neurol.*, 7: 162-176.

Ito, M. (1974) Control mechanisms of cerebellar motor systems. In: *The Neuroscience Third Study Program*. Schmitt, F.O. and Worden, F.G. (eds.). Cambridge: MIT Press, 293-303.

Kelso, J.A.S. (1977) Motor control mechanisms underlying human movement production. *J. Exp. Psychol.*, 3: 529-543.

Komi, P.V. (1973) Relationship between muscle tension, EMG and velocity of contraction under concentric and eccentric work. In: *New Concepts of the Motor Unit, Neuromuscular Disorders, Electromyographic Kinesiology*. Desmedt, J.E. (ed.). Basel: Karger. 596-606.

Kornhuber, H.H. (1971) Motor functions of cerebellum and basal ganglia: the cerebello-cortical saccadic (ballistic) clock, the cerebello-nuclear hold regulator, and the basal

- ganglia ramp (voluntary speed smooth movement) generator. *Kybernetik*, 8: 157-162.
- Körnhuber, H.H. (1974) Cerebellar cortex, cerebellum and basal ganglia. An introduction to their motor function. In: *The Neurosciences Third Study Program*. Schmitt, F.O. and Worden, F.G. (eds.). Cambridge: MIT Press, 267-280.
- Lamarre, Y. and Jaks, B. (1978) Involvement of the cerebellum in the initiation of fast ballistic movement in the monkey. *Electroenceph. clin. Neurophysiol. Suppl.*, 34: 441-447.
- Lamarre, Y., Spidalieri, G., Busby, L. and Lund, J.P. (1980) Programming of initiation and execution of ballistic arm movements in the monkey. *Prog. Brain Res.*, 54: 157-169.
- Lee, R.G. and Tatton, W.G. (1975) Motor responses to sudden limb displacements in primates with specific CNS lesions and in human patients with motor system disorders. *Can. J. Neurol. Sci.*, 2: 285-293.
- Lestienne, F. (1979) Effects of inertial load and velocity on the braking process of voluntary limb movements. *Exp. Brain Res.*, 35: 407-418.
- Lestienne, F., Polit, A. and Bizzi, E. (1981) Functional organization of the motor process underlying the transition from movement to posture. *Brain Res.*, 230: 121-131.
- Lippold, O.C.J. (1952) The relation between integrated action potentials in a human muscle and its isometric tension. *J. Physiol.*, 117: 492-499.
- Marsden, C.D., Obeso, J.A. and Rothwell, J.C. (1983) The function of the antagonist muscle during fast limb movements in man. *J. Physiol.*, 335: 1-13.
- Meinck, H.-M., Benecke, R., Meyer, W., Hohne, J. and Conrad, B. (1984) Human ballistic finger flexion: uncoupling of the three-burst pattern. *Exp. Brain Res.*, 55: 127-133.
- Meyer-Lohmann, J., Hore, J. and Brooks, V.B. (1977) Cerebellar participation in generation of prompt arm movements. *J. Neurophysiol.*, 40: 1038-1050.
- Michie, P.T., Clarke, A.M., Sinden, J.D. and Glue, L.C.T. (1976) Reaction time and spinal excitability in a simple reaction time task. *Physiol. Behav.*, 16: 311-315.
- Milner-Brown, H.S., Stein, R.B. and Yemm, R. (1973) Changes in firing rate of human motor units during linearly changing

- voluntary contractions. *J. Physiol.*, 230: 371-390..
- Morasso, P. (1981) Spatial control of arm movements. *Exp. Brain Res.*, 42: 223-227.
- Moritz, U., Svantesson, G. and Haffajee, D. (1973) *A biomechanical study of muscle torque as affected by motor unit activity, length-tension relationship and muscle force level. In: *New Concepts of the Motor Unit, Neuromuscular Disorders, Electromyographic Kinesiology*. Desmedt, J.E. (ed.). Basel: Karger, 675-682.
- Munhall, K.G. and Kelso, J.A.S. (1985) The role of similarity analysis in understanding movement. *J. Mot. Behav.*, 17: 493-498.
- Nelson, W.L. (1983) Physical principles for economies of skilled movements. *Biol. Cybern.*, 46: 135-147.
- Nickerson, R.S. (1973) Intersensory facilitation of reaction time: energy summation or preparation enhancement. *Psychol. Rev.*, 80: 489-509.
- O'Riain, M.D., Blair, R.D. and Murphy, J.T. (1979) Modifiability of the stretch reflex by prior information. *Electromyogr. clin. Neurophysiol.*, 19: 57-63.
- Oscarsson, O. (1973) Functional organization of spinocerebellar paths. In: *Handbook of Sensory Physiology, Somatosensory Systems*. Iggo, A. (ed.). Berlin: Springer-Verlag. 339-380.
- Peters, W. and Wenborne, A.A. (1936) The time pattern of voluntary movements. *Brit. J. Psychol.*, 26: 388-406.
- Pierrot-Deseilligny, E. and Lacert, P. (1973) Amplitude and variability of monosynaptic reflexes prior to various voluntary movements in normal and spastic man. In: *Human Reflexes, Pathophysiology of Motor Systems, Methodology of Human Reflexes*. Desmedt, J.E. (ed.). Basel: Karger, 538-549.
- Polit, A. and Bizzi, E. (1979) Characteristics of motor programs underlying arm movements in monkeys. *J. Neurophysiol.*, 42: 183-194.
- Ralston, H.J., Inman, V.T., Strait, L.A. and Shaffrath, M.D. (1947) Mechanics of human isolated voluntary muscle. *Am. J. Physiol.*, 151: 612-620.
- Richer, P. (1895) Du mode d'action des muscles antagonistes dans des mouvements tres rapides, alternativement de sens inverse. *C. Searc. Co. Biol.*, 47: 171-173.

- Robinson, D.A. (1968) Eye movement control in primates. *Science*, 161: 1219.
- Rothwell, J.C., Traub, M.B. and Marsden, C.D. (1982) Automatic and 'voluntary' responses compensating for disturbances of human thumb movements. *Brain Res.*, 248: 33-41.
- Rothwell, J.C., Traub, M.M., Day, B.L., Obeso, J.A., Thomas, P.K. and Marsden, C.D. (1982) Manual motor performance in a deafferented man. *Brain*, 105: 515-542.
- Sanes, J.N. and Evarts, E.V. (1983) Effects of perturbations on accuracy of arm movements. *J. Neurosci.*, 3: 977-986.
- Sanes, J.N. and Jennings, V.A. (1984) Centrally programmed patterns of muscle activity in voluntary motor behavior of humans. *Exp. Brain Res.*, 54: 23-32.
- Schieber, M.H. and Thach, W.T. (1985) Trained slow tracking. II. Bidirectional discharge patterns of cerebellar nuclear, motor cortex and spindle afferent neurons. *J. Neurophysiol.*, 54: 1228-1270.
- Schmidt, R.A. (1972) The index of preprogramming (IP): A statistical method for evaluating the role of feedback in simple movements. *Psychonom. Sci.*, 27: 83-85.
- Schmidt, R.A., Zelaznik, H., Hawkins, G., Frank, J.S. and Quinn, J.T. (1979) Motor-output variability: A theory for the accuracy of rapid motor acts. *Psychol. Rev.*, 86: 415-451.
- Singh, M. and Karpovich, P.V. (1966) Isotonic and isometric forces of forearm flexors and extensors. *J. Appl. Physiol.*, 21: 1435-1437.
- Soechting, J.F. and Lacquaniti, F. (1981) Invariant characteristics of a pointing movement in man. *J. Neurosci.* 1: 710-720.
- Soechting, J.F. and Lacquaniti, F. (1983) Modification of trajectory of a pointing movement in response to a change in target location. *J. Neurophysiol.*, 49: 548-562.
- Stern, Y., Mayeux, R., Rosen, J. and Ilson, J. (1982) Perceptual motor dysfunction in Parkinson's disease: a deficit in sequential and predictive voluntary movement. *J. Neurol. Neurosurg. Psychiat.*, 46: 145-151.
- Stetson, R.H. and McDill, J.A. (1923) Mechanism of the different types of movement. *Psychol. Monographs*, 32: 18-45.

- Sullivan, S.J. (1980) Conditional H-reflexes prior to movement. *Brain Res.*, 192: 564-569.
- Tatton, W.G. and Lee, R.G. (1975). Evidence for abnormal long-loop reflexes in rigid Parkinsonian patients. *Brain Res.*, 100: 671-676.
- Taylor, F.V. and Birmingham, H.P. (1948) Studies of tracking behaviours. II. The acceleration pattern of quick manual corrective responses. *J. Exp. Psych.*, 38: 783-795.
- Terzuolo, C.A. and Viviani, P. (1973) Parameters of motion and EMG activities during some simple motor tasks in normal subjects and cerebellar patients *In: The Cerebellum, Epilepsy and Behaviour*, Cboper, I.S., Riklan, M. and Snider, R.S. (eds.). New York: Plenum Press, 173-215.
- Terzuolo, C.A., Soechting, J.F. and Viviani, P. (1973) Studies on the control of simple motor tasks. I. Relations between parameters of movements and EMG activities. *Brain Res.*, 58: 212-216.
- Thach, W.T. (1975) Timing of activity in cerebellar dentate and cerebral motor cortex during prompt volitional movement. *Brain Res.*, 88: 233-241.
- Thach, W.T. (1978) Correlation of neural discharge with pattern and force of muscular activity joint position, and direction of intended movement in motor cortex and cerebellum. *J. Neurophysiol.*, 41: 654-676.
- Thomas, J.S., Brown, J. and Lucier, G.E. (1977) Influence of task set on muscular responses to arm perturbations in normal subjects and Parkinson's patients. *Exp. Neurol.*, 55: 618-628.
- Thomas, J.S., Croft, D. and Brooks, V.B. (1975) A manipulandum for humans motor studies. *IEEE Trans. Biomed. Eng.*, 23: 83-84.
- Tilney, F. and Pike, F.H. (1925) Muscular coordination experimentally studied in its relation to the cerebellum. *Arch Neurol. Psychiat.*, 13: 289-334.
- Vince, M.A. (1948) Corrective movements in a pursuit task. *Quart. J. Psychiat.*, 1: 85-106.
- Viitasalo, J.T. (1982) Function of the knee extensor muscles during fatigue. *In: Biomechanics VIII*, Baltimore: Univ. Park Press.
- Wachholder, K. and Alternburger, H. (1926) *Beitrage zur Physio-*

Die der willkürlichen Bewegung. 10 Einzelbewegungen. Pflügers Arch. Geo. Physiol., 214: 642-661.

Wadman, W.J., Denier van der Gon, J.J., Geuze, R.H. and Mol, C.R. (1979) Control of fast goal-directed arm movements. J. Human Mov. Stud., 5: 5-17.

Welford, A.T. (1968) Fundamentals of Skill. London: Methuen.

Wilkie, D.R. (1950) The relation between force and velocity in human muscle. J. Physiol., 110: 249-280.

Woodworth, R.S. (1899) The accuracy of voluntary movement. Psychol. Mon., Suppl. 3: 114:121.

END

14 04 87

FIN