

1983

# The Effects Of Exercise On Capillary Supply To The 'transition Zone' Of Infarcted Rat Hearts

Karin Przyklenk

Follow this and additional works at: <https://ir.lib.uwo.ca/digitizedtheses>

---

## Recommended Citation

Przyklenk, Karin, "The Effects Of Exercise On Capillary Supply To The 'transition Zone' Of Infarcted Rat Hearts" (1983). *Digitized Theses*. 1243.

<https://ir.lib.uwo.ca/digitizedtheses/1243>

This Dissertation is brought to you for free and open access by the Digitized Special Collections at Scholarship@Western. It has been accepted for inclusion in Digitized Theses by an authorized administrator of Scholarship@Western. For more information, please contact [tadam@uwo.ca](mailto:tadam@uwo.ca), [wlsadmin@uwo.ca](mailto:wlsadmin@uwo.ca).

The author of this thesis has granted The University of Western Ontario a non-exclusive license to reproduce and distribute copies of this thesis to users of Western Libraries. Copyright remains with the author.

Electronic theses and dissertations available in The University of Western Ontario's institutional repository (Scholarship@Western) are solely for the purpose of private study and research. They may not be copied or reproduced, except as permitted by copyright laws, without written authority of the copyright owner. Any commercial use or publication is strictly prohibited.

The original copyright license attesting to these terms and signed by the author of this thesis may be found in the original print version of the thesis, held by Western Libraries.

The thesis approval page signed by the examining committee may also be found in the original print version of the thesis held in Western Libraries.

Please contact Western Libraries for further information:

E-mail: [libadmin@uwo.ca](mailto:libadmin@uwo.ca)

Telephone: (519) 661-2111 Ext. 84796

Web site: <http://www.lib.uwo.ca/>

# CANADIAN THESES ON MICROFICHE

I.S.B.N.

## THESES CANADIENNES SUR MICROFICHE



National Library of Canada  
Collections Development Branch

Canadian Theses on  
Microfiche Service

Ottawa, Canada  
K1A 0N4

Bibliothèque nationale du Canada  
Direction du développement des collections

Service des thèses canadiennes  
sur microfiche

### NOTICE

The quality of this microfiche is heavily dependent upon the quality of the original thesis submitted for microfilming. Every effort has been made to ensure the highest quality of reproduction possible.

If pages are missing, contact the university which granted the degree.

Some pages may have indistinct print especially if the original pages were typed with a poor typewriter ribbon or if the university sent us a poor photocopy.

Previously copyrighted materials (journal articles, published tests, etc.) are not filmed.

Reproduction in full or in part of this film is governed by the Canadian Copyright Act, R.S.C. 1970, c. C-30. Please read the authorization forms which accompany this thesis.

THIS DISSERTATION  
HAS BEEN MICROFILMED  
EXACTLY AS RECEIVED

### AVIS

La qualité de cette microfiche dépend grandement de la qualité de la thèse soumise au microfilmage. Nous avons tout fait pour assurer une qualité supérieure de reproduction.

S'il manque des pages, veuillez communiquer avec l'université qui a conféré le grade.

La qualité d'impression de certaines pages peut laisser à désirer, surtout si les pages originales ont été dactylographiées à l'aide d'un ruban usé ou si l'université nous a fait parvenir une photocopie de mauvaise qualité.

Les documents qui font déjà l'objet d'un droit d'auteur (articles de revue, examens publiés, etc.) ne sont pas microfilmés.

La reproduction, même partielle, de ce microfilm est soumise à la Loi canadienne sur le droit d'auteur, SRC 1970, c. C 30. Veuillez prendre connaissance des formules d'autorisation qui accompagnent cette thèse.

LA THÈSE A ÉTÉ  
MICROFILMÉE TELLE QUE  
"NOUS L'AVONS REÇUE"

THE EFFECTS OF EXERCISE ON CAPILLARY SUPPLY  
TO THE 'TRANSITION ZONE' OF INFARCTED RAT HEARTS

by

Karin Przyklenk

Department of Biophysics

Submitted in partial fulfillment  
of the requirements for the degree of  
Doctor of Philosophy

Faculty of Graduate Studies  
The University of Western Ontario  
London, Ontario  
November, 1982

© Karin Przyklenk, 1982.

### Abstract

Within six to nine hours following coronary artery occlusion, muscle fibers adjacent to the developing necrosis (those in the border or 'transition' zone) are thought to be viable but potentially ischemic; however, their long-term (>24 hour) fate is not known. My initial objective was to determine whether a transition zone is present in an animal model of chronic myocardial infarction. As ischemia implies reduced oxygenation, possibly due to reduced capillary supply, I quantified the numbers and positions of capillaries in the region adjacent to the necrosis in infarcted hearts, and compared these to values in healthy myocardium. Six variables were used in the analysis:  $V_f$  (number of vessels surrounding each fiber),  $F_v$  (number of fibers sharing each vessel), C/F (capillary to fiber) ratio, fiber diameter and intercapillary distance.

Myocardial infarcts were produced in rats by ligating the left coronary artery (LCA) midway along its course. Five weeks later, values of mean  $V_f$ ,  $F_v$ , C/F ratio and capillary density were found to be significantly less in the transition zone than measured in healthy rat myocardium. A tendency toward fiber hypertrophy and increased intercapillary distance was also observed, but did not prove significant. The region of reduced capillary supply extended 375  $\mu\text{m}$  from the edge of the necrosis. These results confirm the chronic presence of a transition zone (viable muscle fibers with a subnormal microvascular supply) in the rat model of myocardial infarction. Application of the Krogh Cylinder Model for oxygen diffusion indicates that, at the venous end of the capillary

bed, these fibers become anoxic when their oxygen consumption rate exceeds 1.5x the resting value.

Evidence from the literature indicates that exercise can stimulate capillary growth in skeletal muscle and healthy myocardium. My second objective was to determine whether exercise can also promote revascularization in the transition zone.

One week following LCA occlusion, rats were allotted into one of four voluntary exercise protocols: A (2 hours of running/day, 6 days/week, 4 weeks), B (2 hours/day, 3 days/week (Monday, Wednesday, Friday), 4 weeks), C (2 hours/day, 6 days/week, 2 weeks, followed by 2 weeks of inactivity) and D (2 hours/day, 6 days/week, 2 weeks).

Voluntary exercise was associated with significant improvements in capillary supply in the transition zone. Important factors included:

(1) an intermediate total distance run. Rats (group A) that ran 5 to 10 km in the month restored normal values of  $V_f$ ,  $F_v$  and C/F ratio in the transition zone, whereas no significant increases occurred in animals running < 5 km or > 10 km.

(2) a balance between exercise frequency and mean running speed. Rats in group B (3 days/week) had to run twice the daily distance of those in group A to obtain the same improvement in capillary supply.

(3) regular reinforcement of the exercise periods throughout the experiment. Animals in groups B and D demonstrated significant increases in  $V_f$ ,  $F_v$  and C/F ratio in the transition zone, while those in group C did not.

A further group of rats was forced to run 2 hours/day,

6 days/week, for 4 weeks following coronary artery occlusion. No increases in mean  $V_f$  and C/F ratio were observed; however, changes in  $F_v$  as a function of distance run were similar to those of the comparable voluntary exercise protocol.

The mechanism by which exercise stimulates capillary growth is not known. It is possible that local tissue hypoxia and increased coronary blood flow in the transition zone during exercise may be responsible for the revascularization observed.

### Acknowledgements

I would like to extend my sincere thanks to the following individuals and organizations:

- Dr. Alan C. Groom, my supervisor, for his advice and support during my years as a graduate student.

- the members of my advisory committee - Dr. Margot R. Roach, Dr. Peter A. Rechnitzer and Dr. Robert L. Kline - for their interest and encouragement. I owe special thanks to Dr. Roach, who found the time in her busy schedule to read and offer criticisms on the final draft of my thesis.

- my colleagues in the 'microcirculatory group', and my other friends in the Biophysics department. They were never too busy to discuss a problem, offer advice, or lend a hand, and were a constant source of much-needed comic relief. Their presence did much to help me maintain my sanity during the writing of the thesis.

- Ms. Margo Lillie, who painstakingly proofread the final typed text, and Mr. Peter Whittaker, who checked the figures.

- my parents, who instilled in me at an early age the value of an education, and taught me by example that a worthwhile goal can best be attained through a combination of patience and hard work. Their constant support and faith in me are deeply appreciated.

- the Medical Research Council of Canada, which provided me with financial support. The Ontario Heart Foundation, through a research grant to Dr. Groom, provided funds for animals and supplies.



## Table of Contents

Certificate of Examination . . . . .	ii
-Abstract . . . . .	iii
Acknowledgements . . . . .	vi
Table of Contents . . . . .	vii
List of Figures . . . . .	x
List of Photographic Plates . . . . .	xii
List of Tables . . . . .	xiii
CHAPTER ONE: General Introduction . . . . .	1
CHAPTER TWO: Literature Review - Coronary Circulation and Myocardial Infarction . . . . .	12
2.1 Coronary Circulation in the Rat . . . . .	13
2.1.1 Macrocirculation . . . . .	13
2.1.2 Microcirculation . . . . .	16
2.2 Myocardial Infarction . . . . .	22
2.2.1 Definitions . . . . .	22
2.2.2 Development of the necrosis . . . . .	23
2.2.3 Concept of the border zone . . . . .	25
2.2.3.1 Evidence in support of the border zone concept . . . . .	26
2.2.3.2 Evidence disputing the presence of a border zone . . . . .	28
2.2.3.3 Role of the microcirculation in the border zone controversy . . . . .	31
2.2.3.4 The 'border zone' in chronic myocardial infarction . . . . .	33
2.3 Objective . . . . .	34
CHAPTER THREE: Methods . . . . .	36
3.1 Surgery . . . . .	37
3.2 Tissue Processing . . . . .	40
3.3 Data Collection and Analysis . . . . .	43
CHAPTER FOUR: Characterization of the Transition Zone in the Chronically Infarcted Rat Heart . . . . .	52
4.1 Microvascular Evidence for a Transition Zone . . . . .	53
4.1.1 Protocol . . . . .	53
4.1.2 Results . . . . .	54
4.1.3 Discussion . . . . .	60

4.2. Width of the Transition Zone . . . . .	65
4.2.1 Protocol . . . . .	65
4.2.2 Results . . . . .	68
4.2.3 Discussion . . . . .	69
4.3 Implications of the Reduced Capillary Supply on Tissue Oxygenation . . . . .	72
4.3.1 The Krogh Cylinder Model . . . . .	72
4.3.2 Calculations and results . . . . .	76
4.3.3 Discussion . . . . .	82
4.4 Summary . . . . .	86
 CHAPTER FIVE: Effects of Exercise on Capillary Supply . . . . .	 87
5.1 Skeletal Muscle . . . . .	89
5.2 Myocardium . . . . .	90
5.3 Exercise and Myocardial Infarction . . . . .	92
5.3.1 Protocol . . . . .	93
5.3.2 Results . . . . .	94
5.3.3 Discussion . . . . .	101
5.4 Summary . . . . .	112
 CHAPTER SIX: Importance of Exercise Frequency, Intensity and Duration on Revascularization in the Transition Zone . . . . .	 113
6.1 Protocol . . . . .	114
6.2 Results . . . . .	116
6.3 Discussion . . . . .	126
6.4 Summary . . . . .	132
 CHAPTER SEVEN: Comparison of Forced vs. Voluntary Exercise on Revascularization in the Transition Zone . . . . .	 133
7.1 Protocol . . . . .	135
7.2 Results . . . . .	137
7.3 Discussion . . . . .	144
7.4 Summary . . . . .	147
 CHAPTER EIGHT: General Discussion . . . . .	 149
8.1 Reduced Microvascular Supply in the Transition Zone . . . . .	150
8.1.1 Reduction in mean $V_f$ . . . . .	150
8.1.2 Reduction in mean $F_f$ . . . . .	153
8.1.3 Lower values of capillary density and C/F ratio . . . . .	154
8.1.4 Tendency toward fiber hypertrophy and increased intercapillary distance . . . . .	154
8.2 Implications and Importance of the Transition Zone . . . . .	155
8.3 Exercise and Revascularization in the Transition Zone . . . . .	159

8.4 Possible Stimuli for Capillary Growth . . . . .	162
8.4.1 Hypoxia . . . . .	162
8.4.2 Mechanical expansion or 'friction' (shear stress) . . . . .	167
8.4.3 Presence of an unknown chemical . . . . .	169
8.5 Hypothesis . . . . .	169
8.6 Suggestions for Further Study . . . . .	175
Appendix: Anatomical Data . . . . .	177
References . . . . .	180
Vitae . . . . .	190

List of Figures

<u>Figure</u>	<u>Description</u>	<u>Page</u>
1.	Evolutionary development of the heart . . . . .	4
2.	Orientation of muscle fibers in the wall of the human left ventricle . . . . .	7
3.	Position of the major coronary arteries in the rat heart . . . . .	15
4.	Schematic longitudinal and cross-section of the myocardial capillary bed . . . . .	19
5.	Schematic diagram of a rat heart, 5 weeks following occlusion of the left coronary artery . . . . .	42
6.	Frequency distribution of $V_f$ values in controls, SO's, and the transition zone of MI's . . . . .	56
7.	Frequency distribution of $F_f$ values in controls, SO's, and the transition zone of MI's . . . . .	58
8.	Method of sampling capillary density as a function of distance from the edge of the necrosis . . . . .	67
9.	Capillary density as a function of distance from the edge of the necrosis . . . . .	70
10.	Definition of variables used in the Krogh Cylinder Model . . . . .	75
11.	Tissue $pO_2$ in healthy rat myocardium as a function of distance from the nearest capillary . . . . .	79
12.	Tissue $pO_2$ in the transition zone as a function of distance from the nearest capillary . . . . .	81
13.	Mean $V_f$ in the transition zone as a function of total distance run, for rats exercised 6 days/week x 4 weeks . . . . .	96
14.	Mean $F_f$ in the transition zone as a function of total distance run, for rats exercised 6 days/week x 4 weeks . . . . .	98
15.	Mean G/F ratio in the transition zone as a function of total distance run, for rats exercised 6 days/week x 4 weeks . . . . .	100

<u>Figure</u>	<u>Description</u>	<u>Page</u>
16.	Tissue $pO_2$ in the transition zone of rat #2-9 as a function of distance from the nearest capillary . . . . .	106
17.	Mean $V_f$ , $F_v$ and C/F ratio in the transition zone as a function of total distance run: group A . . . . .	119
18.	Mean $V_f$ , $F_v$ and C/F ratio in the transition zone as a function of total distance run: group B . . . . .	121
19.	Mean $V_f$ , $F_v$ and C/F ratio in the transition zone as a function of total distance run: group C . . . . .	123
20.	Mean $V_f$ , $F_v$ and C/F ratio in the transition zone as a function of total distance run: group D . . . . .	125
21.	Mean $V_f$ in the transition zone as a function of total distance run: comparison of forced and voluntary exercise . . . . .	139
22.	Mean $F_v$ in the transition zone as a function of total distance run: comparison of forced and voluntary exercise . . . . .	141
23.	Mean C/F ratio in the transition zone as a function of total distance run: comparison of forced and voluntary exercise . . . . .	143
24.	Calculation of the % volume of the myocardial wall occupied by the transition zone . . . . .	158

List of Photographic Plates

<u>Plate</u>	<u>Description</u>	<u>Page</u>
1.	Cross-section of infarcted rat myocardium stained for NADPH diaphorase activity . . . . .	45
2.	Cross-section of infarcted rat myocardium stained for ATPase activity . . . . .	47

List of Tables

<u>Table</u>	<u>Description</u>	<u>Page</u>
1.	Capillary density measurements in the rat left ventricle . . . . .	21
2.	$V_f$ , $F$ , C/F ratio, fiber diameter, capillary density and intercapillary distance in controls, SO's, and in the transition zone of MI's, 5 weeks following coronary artery occlusion . . . . .	59
3.	M (rate of myocardial oxygen consumption), K (oxygen conductivity), r (capillary radius) and R (tissue cylinder radius) in healthy rat myocardium, and in the transition zone of MI's, 5 weeks following coronary artery occlusion . . . . .	77
4.	Capillary density and R (tissue cylinder radius) in the transition zone of three exercised MI's that demonstrated significant increases in capillary supply in the border region . . . . .	104
5.	$V_f$ , $F$ and C/F ratio in healthy rat hearts, as a function of distance run . . . . .	109
6.	Summary of voluntary exercise protocols . . . . .	115

CHAPTER ONE: Introduction



Every living, metabolizing cell requires oxygen and nutrients, and must dispose of wastes, in order to survive. In multicellular organisms, relatively few cells are in close enough contact with the external environment to obtain oxygen directly by diffusion from their surroundings. For the remainder of the cells, a bulk transport system is required to service their metabolic needs.

The circulatory system, composed of the heart and blood vessels, has evolved to meet this requirement. Using blood as the transport medium, oxygen from the lungs and nutrients absorbed from the gastrointestinal tract are delivered to each cell of the body, while carbon dioxide is returned from the cells to the lungs, and other metabolic wastes are transported to the kidneys for disposal. The circulatory system therefore provides the means by which the cells communicate with the external environment.

The components of the circulatory system differ in both their structure and their function. Arteries carry freshly-oxygenated blood to the tissues of the body, capillaries are the site of the actual exchange of materials between blood and cells, and veins return the deoxygenated blood to the starting point. The entire transport process is dependent on the propulsion of the blood in sufficient quantities, and at adequate pressures, by a well-regulated pump - the heart.

The simplest heart, found in lower vertebrates, consists of an endothelial tube surrounded by a muscular sleeve. A wave of contraction, initiated at the 'venous' end, spreads down the muscle and squeezes a column of blood out the 'arterial' end. Larger vertebrates must deal with greater quantities of blood; to facilitate this, the

Figure 1. Evolutionary development of the heart

- A. simple tubular heart. Arrows indicate the direction of contraction
- B. formation of the atrium and ventricle.
- C. advent of unidirectional valves between the atrium and ventricle, and ventricle and aorta.

(Adapted from Muir, 1971)

A.

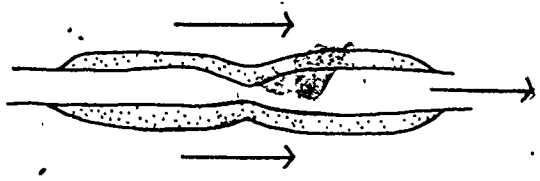

B.

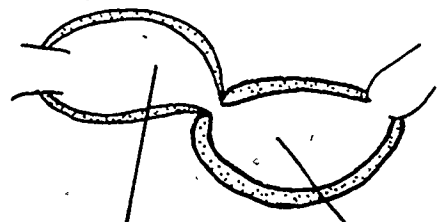

C.

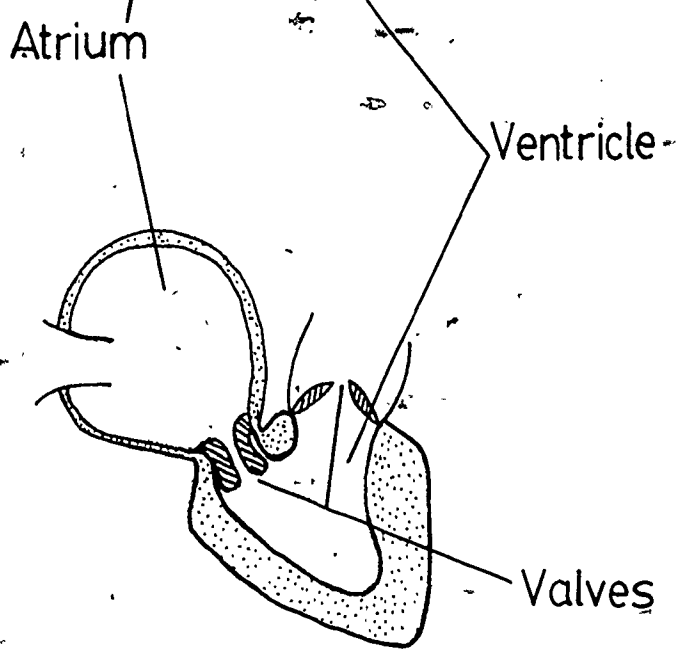

simple tubular heart was enlarged and subdivided into two compartments. In this case, blood first enters the thin-walled atrium, then passes into the thicker, muscular ventricle. With increasing body size, the blood must be pumped from the heart at a higher pressure. Thus, the development of a thicker-walled ventricle was accompanied by the advent of a unidirectional valve between the atrium and ventricle, to prevent backflow when the ventricle pumps blood into the aorta (figure 1).

In birds and mammals, the heart has further evolved into, effectively, two pumps in series: the 'right heart', pumping blood from the body to the lungs for oxygenation (the pulmonary circulation), and the 'left heart', supplying freshly oxygenated blood to the body (the systemic circulation). Septa between the left and right atria and left and right ventricles ensure that oxygenated and deoxygenated blood do not mix. In addition, the entrances and exits to the ventricles are governed by one-way valves which prevent retrograde flow from the outflow vessels back to the ventricles, and from the ventricles to the atria.

The heart pumps blood to the body by the rhythmic contraction of the muscle fibers making up the walls of the left ventricle. Muscle fibers in the heart do not all lie parallel to each other, as in skeletal muscle, nor are they randomly arranged. Rather, the muscle fiber bundles, composed of sheets of parallel fibers, are arranged in layers of complex helices (figure 2). Originating in the area of the atrioventricular junction, the fibers of the superficial layer spiral around the margin of the left ventricle, where they form a vortex and terminate in the papillary muscles. Three deep layers are S-shaped, curving around the circumference of the left ventricle,

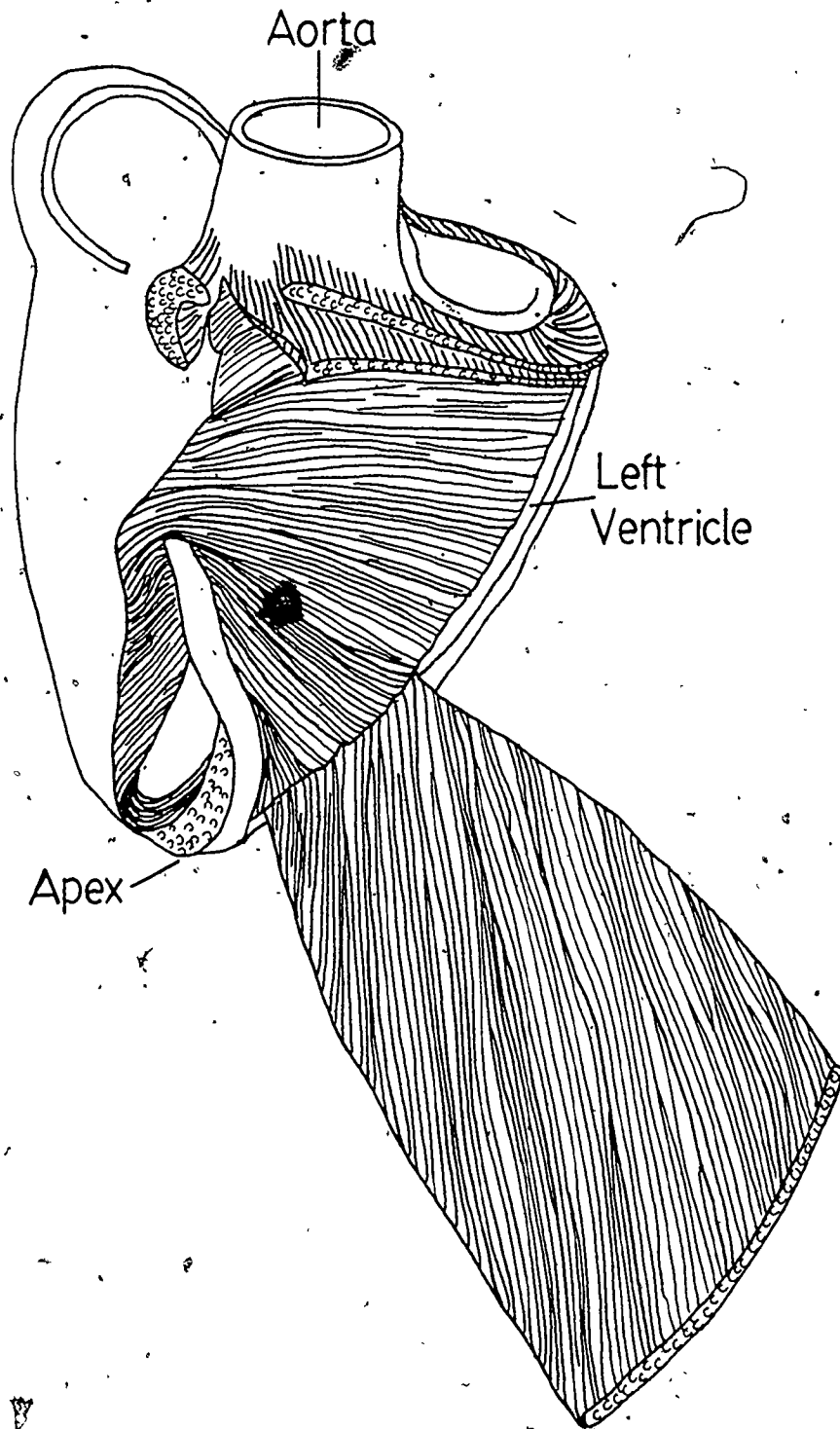

Figure 2: Orientation of muscle fibers in the wall of the human left ventricle.

(Adapted from Muir, 1971)



then through the septum and around the right ventricle. Two additional layers of muscle fibers spiral between the deep and superficial layers. This complex arrangement of fibers is thought to equalize stretch on the individual fibers at all depths of the ventricular wall during diastole, and provide the most efficient means of emptying the ventricle during systole (Muir, 1971).

Because it is composed of living, metabolizing muscle cells, the heart, like all other tissues of the body, requires its own bulk transport system to provide oxygen and nutrients and remove wastes. The coronary circulation, composed of arteries, capillaries and veins, is responsible for bulk transport to and from the cells of the myocardium.

Muscle fibers in the heart have little capacity for anaerobic glycolysis. As the heart is almost solely dependent on oxidative metabolism for its energy production, a constant supply of oxygen to the fibers is essential. During exercise, the heart rate in man can increase to as much as 220 beats/minute; this is accompanied by a four- to five-fold increase in myocardial oxygen demand. Under these conditions, oxygen delivery to the muscle fibers is complicated by the fact that squeezing of the coronary vessels during systole impedes blood flow through them, and the duration of diastole is reduced with increasing heart rate. Thus, the coronary circulation is responsible for supplying a tissue which is continuously active, cannot incur an oxygen debt, and, because of its role as a pump, is an essential element of the bulk transport system to the entire body.

No mechanical pump has been built that can match the long-term performance of the heart. For example, the healthy human heart beats

at least 50 to 65 times per minute, continuously, for an average of 70 years. However, if the flow of blood through the coronary arteries is blocked and myocardial oxygen demand exceeds the amount that can be supplied, myocardial ischemia results. If this imbalance between supply and demand is of sufficient severity or duration, myocardial muscle fibers begin to die. Since muscle fibers, like neurons, cannot be regenerated, this can have serious consequences. If a sufficient number of fibers are affected, such that the ability of the heart to function as a pump is compromised, the survival of the animal is in question.

At present, ischemic heart disease and its complications are recognized as the most common serious health problem and most common cause of death in the developed world (Hillis and Braunwald, 1971). Much research has been done on the diagnosis of ischemia, properties, of ischemic, normal and necrotic myocardium, and the use of hemodynamic and pharmacologic interventions to reduce the extent of myocardial cell death. Many therapeutic interventions designed to limit the size of the necrosis are based on the theory that a salvageable region of tissue, characterized by intermediate ischemic tissue damage, is present in the first six to nine hours following coronary artery occlusion. In recent years, the properties and very presence of this region - the border or transition zone - have been the subject of considerable attention and controversy. In contrast, the long-term fate of the border zone has largely been ignored.

The first objective of my thesis was to determine whether or not an ischemic border zone is present in an animal (rat) model of chronic myocardial infarction. As it is not always possible to



begin treatment within the first six hours following the obstruction of a coronary artery, the long-term presence of a salvageable transition zone could be of clinical importance.

I have chosen to define the presence of a transition zone by a decrease in the microvascular supply with respect to normal, healthy myocardium. In acute myocardial infarction, the border zone is thought to be ischemic; as the actual delivery of oxygen to the muscle fibers occurs at the capillary level, the presence or absence of capillaries is a crucial determinant of potential oxygen supply to the transition zone. My experiments confirmed the presence of a border zone, characterized by a sub-normal microvascular supply, five weeks following coronary artery occlusion in the rat.

My second objective was to ascertain whether or not exercise could serve as a stimulus for revascularization in the transition zone. I chose to use exercise as a 'therapeutic intervention' for two reasons:

(1) considerable evidence presented in the literature indicates that exercise can promote capillary growth in skeletal muscle, and, in some cases, in healthy hearts.

(2) exercise is currently being used in some cardiac rehabilitation programs. These clinical studies concentrate on changes in macroscopic variables (i.e. heart rate, blood pressure, stroke volume, etc.) in response to exercise, but it is not feasible to measure changes in myocardial capillary supply in human subjects. While results obtained from animal experiments cannot be applied directly to humans, my findings suggest that exercise may be of benefit, at the microvascular level, to the hearts of cardiac patients.

Because my thesis involves two distinct yet interrelated concepts - the presence or absence of a transition zone, and the use of exercise as a stimulus for capillary growth - I have chosen to deal first with one topic, then the other. That is, literature pertaining to myocardial infarction and the border zone concept is presented first, with no mention of exercise being made. The methods chapter deals only with the procedures that are common to the entire thesis - surgical coronary artery ligation, tissue preparation, histology, choice of variables, and statistical treatment of the data. This is followed by the first results chapter, which presents my evidence for the presence of a transition zone, and discusses its implications. The results from this chapter form the basis for the remainder of the thesis.

At this point, the literature dealing with exercise and capillary growth is reviewed. By splitting the literature review in this way, the references are in close proximity to the pertinent discussion. Each subsequent exercise chapter includes the specific methods unique to that series of experiments, and a brief discussion of the results. In the final chapter, I have attempted to draw together data from the entire thesis into a coherent unit, discuss my findings as a whole, and present a hypothesis to explain my results.

CHAPTER TWO: Literature Review - Coronary Circulation and  
Experimental Myocardial Infarction

## 2.1 Coronary Circulation in the Rat

As my experiments involve the use of the rat model of myocardial infarction, it is important to first obtain an understanding of the healthy pattern of coronary circulation in this species.

### 2.1.1. Macrocirculation

After branching from the aorta, both major coronary arteries, the left and the right, course through and are surrounded by the cardiac muscle (Selye et al. 1960).

The left coronary artery (LCA) supplies blood to the left ventricular free wall, the left atrium, and the conus region of the right ventricle. It arises from the aorta, in contact with the left margin of the pulmonary cone and approximately one millimeter from the insertion of the left atrium (figure 3A). Distal to its origin, the LCA branches into the septal artery (55% of all cases), which descends along the right surface of the septum, and the circumflex branch, which runs parallel to the coronary groove to the dorsal aspect of the heart. The descending portion of the LCA runs a straight course from its origin to the apex of the heart, giving off many horizontal branches of approximately equal size. Near the apex, the LCA bifurcates into two branches of equal size (Selye et al., 1960; Hebel et al. 1976; Halpern. 1957; Spadaro et al., 1980).

The right coronary artery (RCA) originates from the aorta at the right margin of the pulmonary cone, and immediately subdivides into many principal branches (septal artery in 45% of all cases) which run perpendicular to the main trunk (figure 3B). The RCA and its branches supply blood to both the right ventricular free wall

Figure 3: A. Left aspect and  
B. Right aspect of the rat heart, showing the  
positions of the major coronary arteries.

(Adapted from Halpern, 1957)

A.

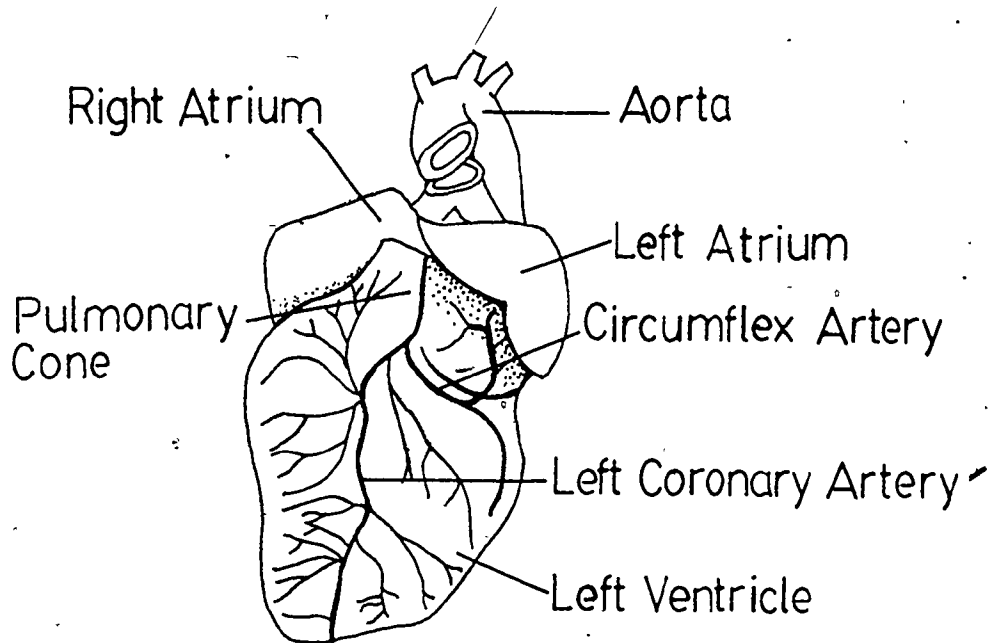

B.

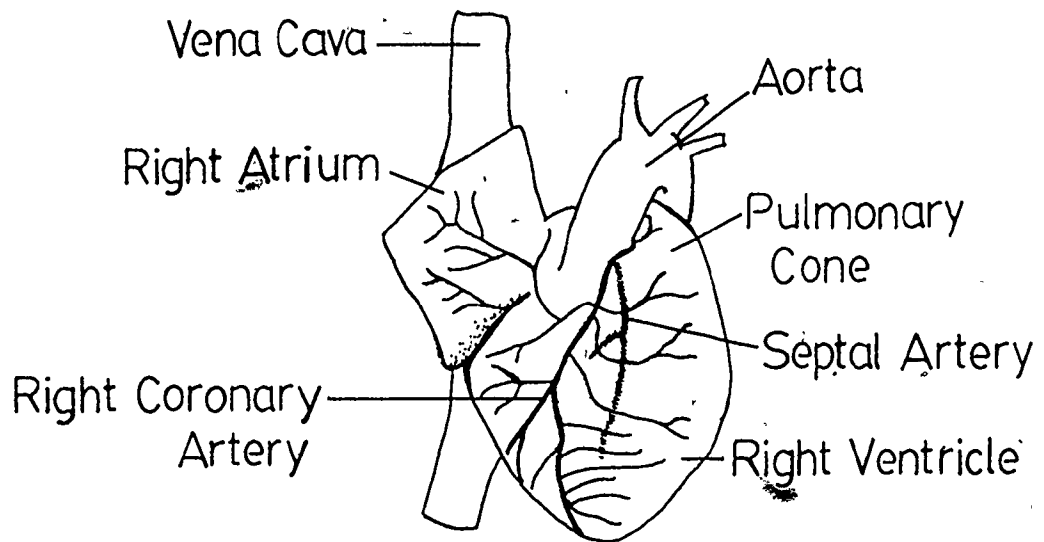

and the right atrium (Selye et al., 1960; Hebel et al., 1976; Halpern, 1957).

Small veins arising from the apex and the ventral aspect of the left ventricular myocardium converge to form the left cardiac vein. This vein courses to the dorsal surface of the left ventricle, where it joins with additional vessels draining this region, and then empties into the coronary sinus. The right ventricular wall is drained by the right cardiac vein and its branches, and empties directly into the caudal aspect of the right atrium. The remainder of the dorsal wall of the rat heart is drained by the dorsal cardiac vein; this vessel originates from many small branches in both the right and left ventricular walls, and terminates in the coronary sinus. Contents of the coronary sinus then empty directly into the right atrium (Halpern, 1953; Selye et al., 1960).

#### 2.1.2. Microcirculation

Arterioles, defined by Folkow and Neil (1971) as afferent vessels lined with endothelium that is surrounded by one layer of smooth muscle and a minimum of connective tissue, branch perpendicularly from the arteries and course obliquely along the muscle fibers within the connective tissue septa (Ludwig, 1971). The arterioles bifurcate dichotomously in three dimensions, giving rise to daughter branches smaller in diameter than the parent branch. These daughter branches lie parallel to the muscle fibers and often run in opposite directions, thereby providing the most efficient pattern to densely vascularize the tissue. Any given region of myocardium is supplied by many arterioles, often arising from different arterial sources.

Anastomotic connections between arterioles ('preferential channels'

or 'arterial arcades') have not been observed in the rat heart (Ludwig, 1971; Brown, 1965).

Arterioles continue to branch dichotomously and eventually give rise to two daughter capillaries, composed of a single layer of endothelial cells (Folkow and Neil, 1971). The capillaries run parallel to the muscle fibers, branch extensively with little change in caliber, and are interconnected with an abundance of short (20  $\mu$ m in length) anastomoses. Capillary branches often double back and proceed in a direction opposite to that of the parent; in addition, adjacent branches often carry blood in opposite directions. Most muscle fibers are supplied by capillaries which originate from more than one arteriole (Brown, 1965; Ludwig, 1971). This is illustrated schematically in figure 4.

Capillaries from all directions and arising from many different arterioles come together to form a dense meshwork before joining in a tuft-like manner, known as a 'turnip root configuration', to form a venule. The venules cross the muscle fibers obliquely to join veins, which run in flat sheets in the connective tissue spaces between the fiber bundles (Brown, 1965; Ludwig, 1971).

While several authors have provided a qualitative description of the coronary microvasculature in several species, there is a ". . . lack of anatomical data, not only as to the number of capillaries, but also their arrangement and distribution" (Martini et al., 1969). As the capillary supply and geometry is the crucial determinant of oxygen, carbon dioxide, nutrient and metabolite transport to and from the cardiac muscle fibers (Rakusan, 1971a), this is a subject of considerable importance and interest.



Figure 4: A. Schematic longitudinal section of the myocardial capillary bed, demonstrating:

1. anastomoses between daughter capillaries of a terminal arteriole.

2. anastomoses between capillaries of daughter arterioles.

3. anastomoses between capillaries of arterioles from a distant dichotomous branching.

B. Schematic cross-section of the same myocardial capillary bed, illustrating that any given cardiac muscle fiber is supplied by capillaries arising from several terminal arterioles.

(Adapted from Brown, 1965)

A.

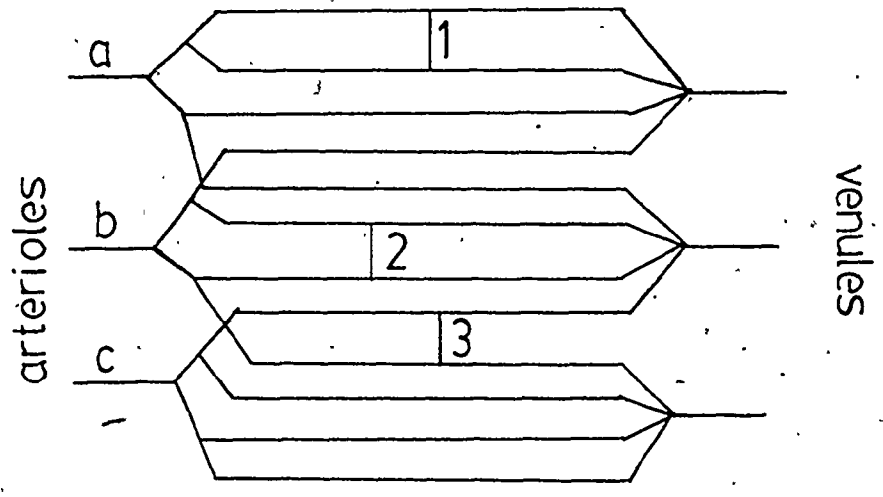

B.

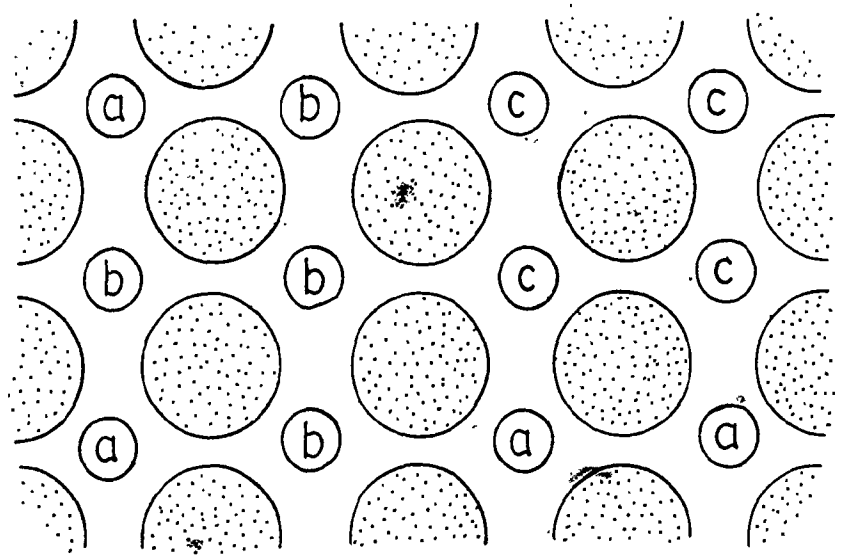

Wearn (1928) was the first investigator to show that, when viewed in cross section, the capillaries and muscle fibers of the heart form a regular arrangement. He and others have observed that each muscle fiber is positioned within a 'crystal lattice' of capillaries, and that the ratio of the number of capillaries to muscle fibers per unit area is approximately equal to one (Hort, 1955; Hort, 1971; Brown, 1965; Ludwig, 1971).

More recently, the capillary supply to the heart has been quantified by counting the number of vessels and fibers per square millimeter from histological cross sections. Data obtained from such density measurements shows tremendous variation (table 1), due to different methods used to visualize the capillaries, and shrinkage of the tissue during fixation and histological processing. There appear to be in the order of 2,000 to 4,000 capillaries per  $\text{mm}^2$  in the adult hearts of most species, and approximately 2,600 capillaries per  $\text{mm}^2$  in the hearts of adult rats (Rakusan, 1971a). It should be noted that 20% to 50% of these capillaries are thought to be unperfused during normal conditions, thereby providing a 'capillary reserve' during periods of hypoxia or increased metabolic demand (Henquell et al., 1976; Martini et al., 1969).

In vivo measurements of capillary diameter and position have been made using cinematography of the superficial layers of the beating rat heart (Martini et al., 1969; Henquell et al., 1976; Steinhausen et al., 1978). Mean values of intercapillary distance in the normoxic rat heart range from approximately 15  $\mu\text{m}$  (Henquell et al., 1976) to 19  $\mu\text{m}$  (Steinhausen et al., 1978); in anoxia, the intercapillary distance was shown by Henquell et al. (1976) to decrease to a minimum

Table 1

Capillary density measurements in the rat left ventricle\*

Author	Method	# per mm <sup>2</sup>
Heroux & Pierre (1957)	rbc staining	1,342
Rakusan & Poupa (1963)	dye injection	2,678
Angelakos (1963)	dye injection	3,550
Gautier et al. (1964)	dye injection	2,180
Poupa et al. (1964)	dye injection	2,642
Rakusan & Poupa (1964)	dye injection	2,627
Rakusan & Poupa (1964)	histochemical	2,908
Wachtlova et al. (1967)	histochemical	2,908
Stofer (1968)	dye injection	1,795
Tomanek (1970)	dye injection	4,000
Turek et al. (1972)	histochemical	2,400
Clark et al. (1978)	dye injection	2,600
Turek et al. (1978)	histochemical	2,500

\* First nine entries in the table adapted from Rakusan (1971a).

value of 12.4  $\mu\text{m}$ , implying that more capillaries are perfused under these conditions. Although this decrease in intercapillary distance was not observed by all authors (i.e. Steinhausen et al., 1978), it would further support the concept of a capillary reserve available during hypoxia. The mean value of capillary diameter in the beating rat heart was found to be approximately 6  $\mu\text{m}$  (Steinhausen et al., 1978).

On the microcirculatory level, the rat and human hearts (and in fact all species studied to date) appear to be very similar. Both are characterized by a dense network of capillaries, which run parallel to the muscle fibers. Numerous intercapillary anastomoses were observed in human hearts, but no information concerning direction of flow (countercurrent or cocurrent) is available (Ichikawa et al., 1977). Histologically, Roberts and Wearn (1941) and Hort (1955) noted that, as in the animal models, each muscle fiber is positioned within a remarkably regular lattice of capillaries, and the ratio of capillaries to muscle fibers is approximately equal to one. While the dimensions of the fibers may differ, information to date indicates that the relative geometry of capillaries and muscle fibers in the heart is common to all species studied (Brown, 1965; Rakusan, 1971a).

## 2.2 Myocardial Infarction

### 2.2.1 Definitions

Myocardial ischemia, defined as the deprivation of oxygen to the heart secondary to reduced perfusion, occurs when the metabolic oxygen demand of the heart exceeds the oxygen supplied by the flow of blood to the myocardium (Hillis and Braunwald, 1977; Reimer, 1980). This imbalance between oxygen supply and demand can result from a

gradual narrowing of the lumen of the coronary arteries (Buja et al., 1981), acute coronary artery occlusion by ligation or thrombosis (Selye et al., 1960; Buja et al., 1981), or biochemically induced increases in myocardial oxygen demand (Darrah et al., 1982). If the ischemia is of sufficient severity and/or duration to produce cell death, this process is termed "myocardial infarction" (Hearse and Yellon, 1981).

#### 2.2.2 Development of the necrosis

The healing of a myocardial infarction involves the removal of the dead muscle fibers and their replacement by connective tissue to form a firm, fibrous scar (Mallory et al., 1939). It should be noted that muscle fibers, like neurons, cannot be regenerated (Hort, 1971). In the rat, this process of scar formation is complete after approximately 21 days; the healing period may vary, depending on the location (and thus the size) of the infarct, and the competence of the remaining circulation (Mallory et al., 1939).

The evolution of the lesion can be considered in two phases (Dusek et al., 1971):

(1) the degenerative phase, which lasts up to 48 hours following coronary artery occlusion.

(2) the reparative phase, which occurs from 96 hours to 21 days after the occlusion.

Within one minute after the coronary artery is blocked, the region distal to and supplied by the occluded vessel is observed to blanch and protrude, and then become cyanotic. Only the margin of this zone is capable of weak contraction, thus the remaining tissue attempts to compensate with an increased force of contraction

(Hillis and Braunwald, 1977).

As soon as five minutes after occlusion, there is a significant decrease in glycogen stores and glycolytic enzymes, due to a rapid shift from aerobic to anaerobic metabolism (Fine et al., 1966; Fishbein et al., 1978). After 30 minutes, marked left ventricular dilatation, vascular congestion and interstitial edema are observed; abnormalities in myocardial tissue stained with hematoxylin and eosin are also present by this time (Fine et al., 1966). Significant depletion of dehydrogenases and reductases begin 90 minutes following occlusion, and regional lipid depletion was observed four hours after ligation (Fine et al., 1966).

Invasion of the ischemic area by inflammatory cells (lymphocytes and polymorphonuclear cells) is observed to begin as soon as six hours after coronary artery occlusion, and after another four hours the fibers are visibly swollen and distended (Fine et al., 1966). Twenty-four hours following occlusion, a distinct zone of edematous, necrotic fibers is evident, characterized by focal points of hemorrhage along its margin (Fishbein et al., 1978).

By day three, the edema and vascular congestion is less pronounced, and although the inflammatory infiltration is not yet complete, fibroblasts and thin, wavy collagen fibers are already present at the periphery of the necrosis (Fishbein et al., 1978). Thus, scar formation has begun. Invasion of inflammatory cells peaks seven days after coronary artery occlusion and then begins to decline; by this time there is no further evidence of hemorrhage (Fishbein et al., 1978). Increased fibroblast infiltration and collagen deposition continues until day 21, at which time the necrotic muscle fibers have been

replaced by firm, fibrous scar tissue. This process results in the thinning of the affected region of the ventricular wall to approximately 35% of its original thickness, and a 50% reduction in ventricular wall volume (Fishbein et al., 1978).

The healing process described above appears to be independent of the species. Evolution of a myocardial infarction in man is similar to that of the rat, but considerably slower: generally six to eight weeks are required for scar formation in man, whereas only 21 days are required in the rat (Mallory et al., 1971; Fishbein et al., 1978). The more rapid rate of repair in experimental animals is attributed to their higher rate of metabolism, thinner ventricular walls, and usually healthy cardiac circulation prior to coronary artery occlusion (Mallory et al., 1939; Fishbein et al., 1978).

### 2.2.3 Concept of the border zone

The progression of 'condemned tissue' - cells in which ischemic damage following coronary artery occlusion is so severe that death is inevitable (Hearse and Yellon, 1981) - to a fibrous scar has been well documented. The fate of the muscle fibers at the edge of the lesion, however, is not well understood, and is the subject of considerable controversy.

In the classical model of myocardial infarction, the central necrosis is thought to be surrounded by a viable band of tissue with intermediate ischemic damage which blends gradually into normal myocardium (Cox et al., 1968; Fishbein et al., 1978; Braunwald et al., 1971). This band of tissue, referred to as the 'border zone' or 'transition zone', is believed to be salvageable within the first six to nine hours following coronary artery occlusion, beyond which



point it will become necrotic (Hearse and Yellon, 1981). Thus, the border zone is the target of most of the current therapeutic interventions aimed at limiting infarct size.

Recently, several authors have provided evidence suggesting that the border between necrotic and viable myocardium is discrete - that is, no potentially salvageable transition zone exists following myocardial infarction (Factor et al., 1978; Janse et al., 1979; Yellon and Hearse, 1981). If this is true, then a re-evaluation of current treatment methods for myocardial infarction is required.

#### 2.2.3.1 Evidence in support of the border zone concept

After coronary artery occlusion in rats, Cox et al. (1968) observed that a zone of intermediate tissue damage could be discerned by staining for dehydrogenase activity. In this zone, mitochondrial swelling was detected as soon as 30 minutes post-occlusion. This was attributed to an increase in the permeability of the mitochondrial membrane, due to increased electron transport and rapid depletion of substrate.

As the lesion evolves, it appears that alternate metabolic pathways, low in energy yield compared to the Krebs' Cycle, become increasingly important in the border zone (Dusek et al., 1971). For example, there is an increase in glucose-6-phosphate dehydrogenase activity, implying activation of the hexose monophosphate shunt which provides ribose for nucleic acid synthesis. In addition, increases in phosphorylase and lactate dehydrogenase activity were also noted; this indicates an increase in glycolysis, to provide energy for phosphate bonds and protein synthesis (Dusek et al., 1971). These pathways are not important in normal myocardium, but their activation

in the border zone may provide the critical energy needed for the survival of the cells. It is interesting to note that these enzymes present in the transition zone resemble those in embryonic cardiac muscle, which is known to be highly resistant to anoxia (Dusek et al., 1971).

A border zone has also been detected on the basis of substrate concentrations. There is more severe glycogen depletion at the margin of the developing necrosis than at the center, perhaps because the periphery is still contracting while the central region is not. These differences persisted even when the necrosis, as detected by staining with hematoxylin and eosin, was established (Fishbein et al., 1978).

While these results imply the presence of a transition zone, they must be interpreted with caution. Intermediate histological or histochemical staining of a tissue is not necessarily equivalent to intermediate tissue injury (Hearse and Yellon, 1981).

Epicardial electrocardiograms showing changes in S-T segment shifts (Braunwald et al., 1974; Maroko et al., 1977; Maroko et al., 1971), and gradients in ATP, creatine phosphate and creatine kinase concentrations between those of the necrosis and the normal myocardium (Maroko et al., 1971; Maclean et al., 1977) have also been used as evidence for the presence of a border zone. These methods, however, have been criticized because of the poor resolution of both electrocardiographic and tissue biopsy-sampling techniques (Hearse and Yellon, 1981).

### 2.2.3.2 Evidence disputing the presence of a border zone

Factor et al. (1978) reconstructed serial sections of dog hearts stained with hematoxylin and eosin, 24 hours after occluding the left anterior descending coronary artery. On any given section, a highly irregular zone of tissue containing islands of both necrotic and normal muscle cells was observed at the margin of the lesion. This zone of tissue, approximately 0.5 cm in width, would correspond to the border zone. However, when the sections were reconstructed, the islands of tissue could all be followed back to either homogeneous normal myocardium or homogeneous necrotic tissue. Thus, no border zone was present; rather, there was a highly irregular but histologically distinct boundary of interdigitating peninsulas of normal and necrotic myocardium (Factor et al., 1978). It should be remembered, however, that by definition the fate of the muscle fibers in the border zone has been decided within nine hours following coronary artery occlusion. By 24 hours, it would theoretically be too late to detect a border zone of intermediate tissue injury (Hearse and Yellon, 1981).

These results are in agreement with the NADH fluorescence studies of Barlow and Chance (1976), Harken et al. (1978) and Simson et al. (1979). NAD is an element of the electron transport chain present in mitochondria. When cells are deprived of oxygen, electron transport slows, resulting in an accumulation of the reduced form of NAD, NADH. This reduced NADH in the anoxic tissue is fluorescent when excited with ultraviolet light, while normoxic tissue containing NAD is not (Simson et al., 1979). Thus, NAD/NADH is a natural intracellular marker which is a sensitive indicator of the adequacy of tissue oxygen supply (Harken et al., 1978).

Following coronary artery occlusion in rats, rabbits and dogs, these authors observed an abrupt transition ( $< 0.1$  mm) between fluorescent and nonfluorescent regions. The boundary between necrotic and normally perfused myocardium was six to eight millimeters in width, highly irregular, and contained islands of fluorescent and nonfluorescent tissue, similar to the islands observed histologically by Factor et al. (1978). These results indicate that there is a steep gradient of tissue  $pO_2$  at the boundary between normal and necrotic myocardium, and do not support the concept of a border zone of intermediate tissue damage (Barlow and Chance, 1976; Harken et al., 1978; Simson et al., 1979).

While these results seem very convincing, it should be noted that the change in NAD from the oxidized to the reduced state occurs over a narrow range of  $pO_2$  values (i.e. at an oxygen concentration of  $10^{-7}$  molar, NAD is 80% oxidized, while at a concentration of  $10^{-8}$  molar, it is 70% reduced (Sugano et al., 1974; Harken et al., 1978)), thus, even a gradual oxygen gradient could generate a sharp NAD/NADH boundary. It is possible that cells which are ischemic but still viable (i.e. those in a border zone) still have a sufficient supply of oxygen to remain nonfluorescent.

Using electrocardiographic, metabolic and histochemical indices of ischemic damage, Janse et al. (1979) also concluded that the border zone in pig hearts was in fact a mixture of normal and necrotic cells, and not a region of intermediate tissue damage. Yellon and Hearse (1981), using a method capable of taking multiple contiguous tissue biopsies, demonstrated sharp interfaces of flow and metabolism between normal and ischemic tissue following coronary

artery occlusion. Again, these results dispute the concept of a border zone of intermediate ischemic injury.

On the basis of these studies, it has been suggested that a border zone of intermediate tissue damage observed up to nine hours following coronary artery occlusion is actually a sampling artifact. That is, what was interpreted to be a region of intermediate flow, metabolism, etc. may in fact have been composed of normal myocardium 'contaminated' with interdigitating regions of necrotic tissue, giving a mixed tissue sample (Factor et al., 1978; Hearse and Yellon, 1981). This artifact has been attributed in part to the inadequate resolution of sampling methods used. To observe a region of gradual change, the resolution of the method used must be more sensitive than the dimensions of the zone to be measured. Many small samples, taken in close proximity to each other, are required if the location and dimensions of a border zone are to be defined. Yellon and Hearse (1981), using their multiple contiguous biopsy technique with a resolution of less than two millimeters, concluded that no quantitatively significant border zone was present.

While the evidence against the presence of a salvageable border zone appears to outweigh that which supports the concept, the issue has not been conclusively resolved. Aside from the potential species differences, three factors must be considered when the results of these studies are interpreted:

- (1) certain substrates, enzymes and metabolites may be present in gradients following coronary artery occlusion, while others may be defined by a sharp interface.

- (2) it may not be valid to use all the variables being measured as

criteria for the degree of cell damage.

(3) some of these studies have attempted to discern a border zone in the lateral plane, while others have made their measurements in the transmural plane. Because the capillaries, which supply oxygen to the muscle fibers, run parallel to these fibers, the two geometries are not interchangeable and may yield completely different results.

#### 2.2.3.3 Role of the microcirculation in the border zone controversy

The presence or absence of an intermediate border zone is highly dependent upon the anatomy of the coronary circulation and microcirculation prior to coronary artery occlusion. Two arrangements, each with different consequences, are possible (Hearse and Yellon, 1981):

(1) each area of myocardium is supplied exclusively by capillaries arising from one artery. That is, there are no arterial anastomoses or interconnections of capillaries arising from separate arteries. Occlusion of one coronary artery would severely reduce the supply of blood to one well-defined region of the heart, while the remainder of the myocardium would be unaffected. This anatomical arrangement predicts a sharp interface between normal and necrotic tissue, and precludes the presence of a border zone.

(2) interconnections between vascular beds arising from different arterial sources, or extensive interdigitation of capillary beds, is present. Occlusion of one coronary artery could produce a region of tissue in which there is a gradient of flow, making the presence of a border zone feasible.

To determine which of these microvascular arrangements most accurately describes the situation in healthy myocardium, Okun et al.

(1979) simultaneously injected different branches of the left anterior descending coronary artery in dogs with different colors of silicone elastomer. Capillary beds at the boundaries of the circulations were found to be "remarkably discrete" where they abutted; there were no interconnections or alternations of capillaries from the different branches of arterial supply, and no mixing of colors within the individual capillaries (Okun et al., 1979; Factor et al., 1981).

Clearly this anatomical arrangement does not support the concept of a border zone. It should be noted, however, that the arterial branches were injected at the same perfusion pressure. This probably does not represent the situation in the beating heart, and may have prevented the perfusion of collateral vessels. Some collateralization was observed in the subepicardium (i.e. two colors of elastomer were found in the same vessels), but this was not widespread (Okun et al., 1979).

Brown (1965), who injected the hearts of several domestic species (including dog) with India Ink, observed that any given area of the heart is supplied by several arterioles whose capillaries are randomly intermeshed. In addition, he found that all capillaries arising from a given arteriole do not empty into the same venule - an observation which was confirmed by Factor et al. (1981). In most cases, the anastomoses between capillaries joined vessels which arose from the same arteriole (Brown, 1965). It is not clear whether anastomoses between vessels arising from different arteries, or different branches of the same artery, were present. This would be very difficult to detect with the method of visualizing capillaries that Brown (1965) used.

These results were confirmed by Ludwig (1971). He observed anastomoses between "distant capillaries", and found that many capillaries emptied into venules which appeared to be part of a different circulatory unit.

Thus, while the key to the question of the transition zone probably lies in the pattern of the myocardial microcirculation, this is in itself an issue which has not yet been adequately resolved. The findings of Brown (1965) and Ludwig (1971) indicate that the vascular beds in the heart are not as discrete as suggested by Okun et al. (1979) and Factor et al. (1981). I believe that if the border zone concept is to be proven or disproven, more detailed study of the myocardial microcirculation is required.

#### 2.2.3.4 The 'border zone' in chronic myocardial infarction

To this point, the border zone has been defined as a region of tissue suffering from intermediate ischemic damage which can be salvaged within the first six to nine hours following coronary artery-occlusion. This concept by definition does not apply once the lesion has healed, as the fate of the muscle fibers at the margin of the necrosis is presumed to have been long since determined. In fact, the long-term properties of the muscle fibers at the edge of the lesion are largely unknown (Dusek et al., 1971).

Up to one month following coronary artery ligation in rats, surviving fibers at the edge of the necrosis were found to stain abnormally. This was attributed to a change in the permeability of the mitochondrial membranes, increased importance of extramitochondrial enzymes, and a shift toward glycolytic pathways of energy production (Dusek et al., 1971).



In addition, Dusek et al. (1971) observed both hypertrophy and atrophy of fibers in this border region. Hypertrophy was attributed to hypoxia and hindered contractility because of the resistance of the neighboring scar, while atrophy was thought to be caused by anoxia and "metabolic exhaustion" (Dusek et al., 1971). In contrast, Factor et al. (1978) and Fishbein et al. (1978) found the fibers in this region to be normal in appearance using both light and electron microscopy.

Thirty-two days following coronary artery occlusion in the rat, Turek et al. (1978) observed a significant decrease in the capillary density (number per  $\text{mm}^2$ ) in the non-necrotic portions of the left ventricle. Fiber density was also significantly less than that found in normal rat hearts (implying fiber hypertrophy), but no significant change in C/F (capillary to fiber) ratio - the quotient of the capillary and muscle fiber densities - was observed. It should be noted, however, that these measurements did not appear to be restricted to the edge of the lesion, but rather were made throughout the remaining non-necrotic tissue.

### 2.3 Objective

The two studies summarized above suggest that a region of tissue which is neither normal nor necrotic is present as long as one month following coronary artery occlusion in the rat, well after scar formation is complete. While this may not represent a 'border zone' as defined previously, it still indicates the presence of an intermediate or transition region between the lesion and normal myocardium.

Evidence for such a transition zone is inconclusive, and the

properties of this region are poorly defined. My initial objective was to determine whether or not a transition zone is present in the chronically infarcted rat heart. As in the more traditional border zone concept, the capillary bed is still the means by which oxygen, nutrients, and metabolites are transported to and from the myocardial muscle fibers after the scar has healed. Thus, using the rat as an animal model, I chose to look for changes in the microvasculature at the edge of the established lesion to define the presence or absence of a transition zone.

CHAPTER THREE: Methods

The purpose of this chapter is to provide a detailed description of the methods on which the entire thesis is based. These include the surgical procedure used to induce myocardial infarction in the rat, processing of the hearts, histological methods used to discern the necrosis and the capillaries, my choice of variables to quantify microvascular supply, and statistical treatment of the data. Methods unique to a specific experiment have not been included here; rather, they are described at the onset of the chapter to which they pertain.

### 3.1 Surgery

Myocardial infarcts were produced in healthy young male Wistar rats (initial body weight approximately 200 gm) by ligating the left coronary artery midway between its origin and the apex of the heart. Except for minor differences, the method for left coronary artery occlusion described by Selye et al. (1960) was followed. Details of the surgical procedure are summarized below:

- (1) Rats were anesthetized with an intraperitoneal injection of sodium pentobarbital (6 mg per 100 gm body weight).
- (2) Fur from the throat and chest was removed with electric clippers or a depilatory agent. The exposed skin was washed with soap and water, and cleansed with alcohol.
- (3) After securing the animal to the surgical table and immobilizing the head, a tracheostomy was performed. A cannula was inserted into the trachea through the incision and connected to a Phipps and Bird small-animal respirator. The rats were ventilated with room air at approximately 60 breaths per minute and 50% to 75% of maximum

inspiratory capacity (estimated visually at the time of surgery).

(4) Using a scalpel, a two cm craniocaudal incision was made through the skin and pectoral muscles, slightly to the left of the sternum and the epigastric artery.

(5) The thorax was then opened by inserting the tips of blunt forceps through the muscle in the third or fourth intercostal space, and the ~~fourth~~ fourth or fifth intercostal cartilage cut with iris scissors.

(6) Retractors were used to spread the chest wall until a clear view of the heart was obtained. Using a moistened swab, the left lung was tucked out of the working area. The pericardium was then opened with a pair of toothed forceps.

(7) Slight pressure was applied to the sides of the thorax with the thumb and index finger of the left hand; this served to partially immobilize the heart and bring it slightly out of the chest cavity.

(8) Using a pair of mosquito hemostats as a needle driver, a small round-bodied needle (taper TF-4) attached to a strand of 4-0 surgical silk (Ethicon N-272) was passed under the left coronary artery, midway along its course.

(9) The heart was released and the ligature knotted and tightened, taking care to apply sufficient force to occlude the vessel but not tear the myocardial wall. If the procedure was performed correctly, the myocardium distal to the ligature was observed to bulge and become cyanotic.

(10) The pectoral muscles and the skin were separately sutured with simple interrupted stitches, using a #19 full-1/2 circle cutting needle and 4-0 silk.

(11) The tracheal cannula was then removed. Once the animal

began to breathe independently, the incision in the trachea was closed using an Ethicon suture, and the muscle and skin sutured with simple interrupted stitches.

(12) If required, mucus was suctioned from the mouth and trachea. The incisions were swabbed with distilled water and the animals returned to their cages. A one week recovery period was allowed before the various experiments were continued. During this time, and in the remainder of the studies, the animals were individually caged and given free access to food and water.

The surgery was not conducted under aseptic conditions, but the instruments were thoroughly cleaned and soaked in alcohol prior to each operation, and exposed skin was cleansed with alcohol before incisions were made. In addition, rats were given daily intramuscular injections of penicillin and dihydrostreptomycin (Pen-di-Strep, BTI Products Inc., Montreal: 0.05 ml per 100 gm body weight) for five days following the surgery.

The mortality rate due to the surgery was approximately 30%; this is comparable to figures cited by other authors performing similar procedures in the rat (Selye et al., 1960; Johns et al., 1954; Turek et al., 1978). Most of the deaths occurred from 30 minutes to 12 hours after occlusion, and seemed to result from either hemorrhage (due to tearing of the ventricular wall), pneumothorax (caused by damage to the lungs during surgery), or massive myocardial infarction (when the ligature was placed closer to the origin of the left coronary artery than intended). Two animals died after the initial 12 hour period, both because of respiratory infection (confirmed by Dean Percy, D.V.M.).

Although the method for coronary artery occlusion which I have described is based on the procedure of Selye et al. (1960), it differs in three respects:

(1) anesthetic. I used sodium pentobarbital rather than ether.

(2) ventilation. My animals were placed on a respirator while the chest was opened, whereas Selye et al. (1960) could perform the procedure with sufficient speed that a respirator was not required.

(3) sutures. I used silk sutures to close the incisions in skin and muscle, while Selye et al. (1960) secured the skin with Michel clips.

None of these differences in protocol were crucial to the actual ligation of the artery. They did, however, provide me with the extra margin of time I required to ensure that I placed the ligature in the correct position along the course of the vessel.

### 3.2 Tissue Processing

At the time of sacrifice, the animals were again anesthetized with an intraperitoneal injection of sodium pentobarbital. The hearts were excised and quick-frozen in a mixture of acetone cooled with dry ice (approximate temperature of  $-78^{\circ}\text{C}$ ). Using an Ames cryostat, serial tissue cross sections, 12  $\mu\text{m}$  in thickness, were cut perpendicular to the septum in the region of the lesion (figure 5).

To clearly differentiate between the scar and the remaining viable myocardium, every tenth frozen section was stained for the presence of NADPH diaphorase activity (Clark et al., 1980). This histochemical technique is based on the enzymatically mediated reduction of a soluble tetrazolium salt (in this case, nitro-blue

Figure 5: Schematic diagram of a rat heart, five weeks following occlusion of the left coronary artery, showing the necrosis and the area sampled - the transition zone.



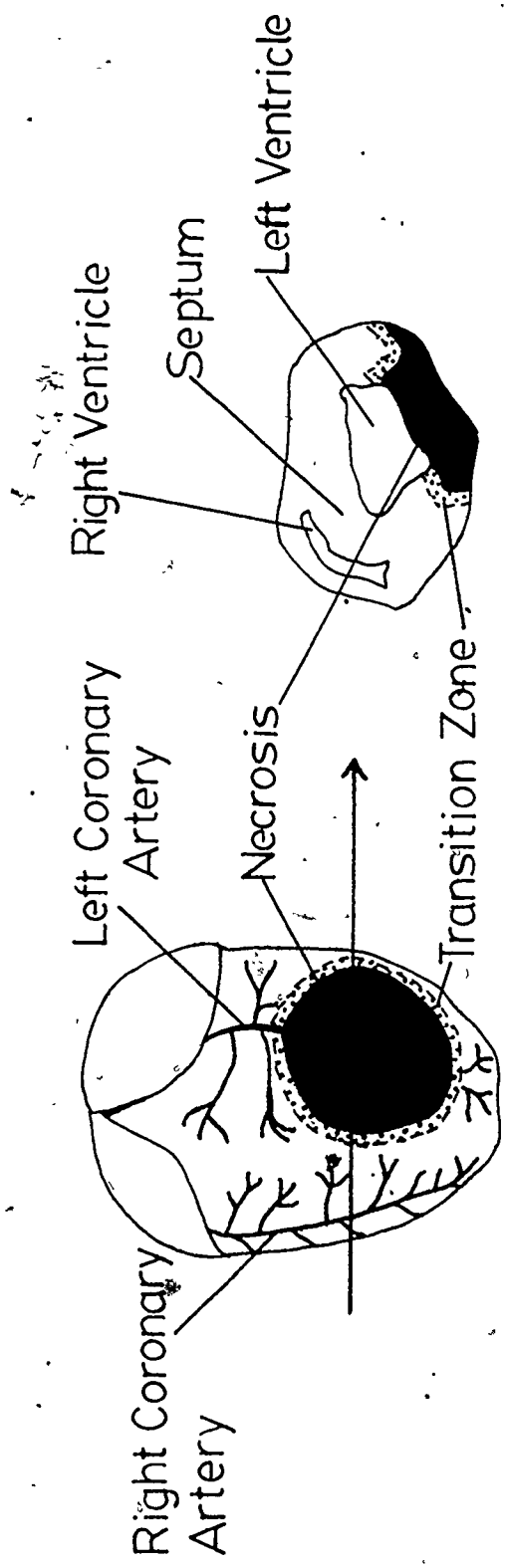

5 mm

tetrazolium) to form a deep purple insoluble formazan precipitate at the site of the enzyme activity (plate 1). As NADPH diaphorase is an enzyme in the Krebs' Cycle, its presence indicates that the region of tissue is undergoing oxidative metabolism (Cox et al., 1968; Dubowitz and Brooke, 1973; Clark et al., 1980; Reimer, 1980). The lesion, however, has no dehydrogenase activity, thus no precipitate forms here and the region remains colorless.

The second and fifth of each group of ten sections was stained for the presence of capillaries using the ATPase method at a pH of 3.8 to 3.9 (Sillau and Banchemo, 1977). In this method (plate 2), cobaltous sulfide, a black insoluble precipitate, is deposited in the endothelial cells of the capillaries wherever the ATPase enzyme is located (Sillau and Banchemo, 1977; Dubowitz and Brooke, 1973).

### 3.3 Data Collection and Analysis

My initial objective was to ascertain whether or not a region of reduced capillary supply exists at the margin of a chronic myocardial lesion and, if so, to quantify the microvascular supply in this transition zone. For the analysis, photomicrographs of the ATPase sections at magnifications of 150x to 300x were taken in the region immediately adjacent to the border of the lesion, as defined by the sections stained for NADPH diaphorase activity. I assumed that the capillaries and muscle fibers adjacent to the necrosis represented the inner edge of the transition zone, should it exist. Fifteen to 25 fields of view, taken from 8 to 16 sections and containing 80 to 300 muscle fibers each, were analysed for each animal:

The microvascular supply was quantified on a 'per muscle fiber'

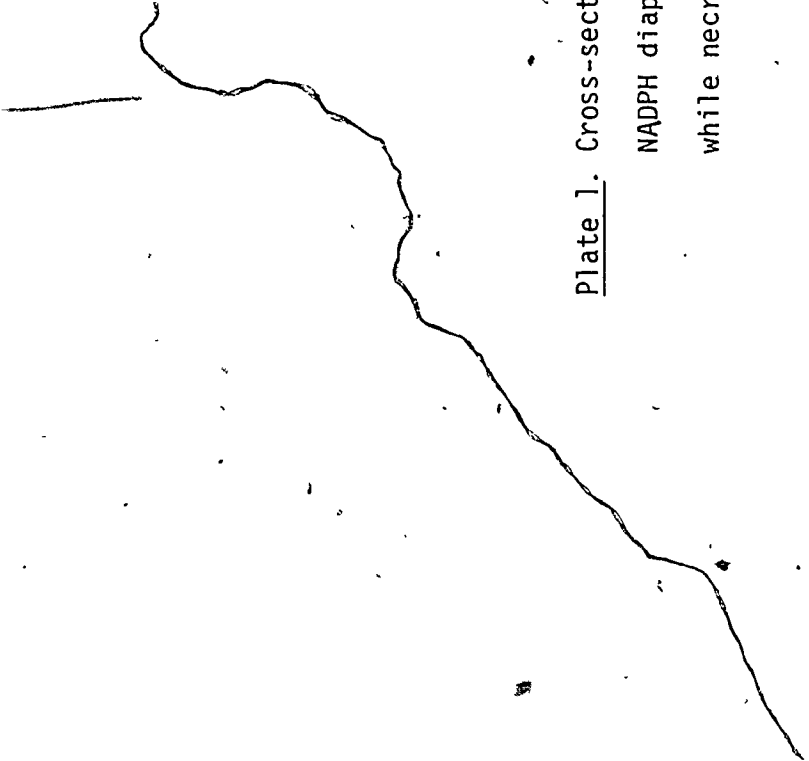

Plate 1. Cross-section of infarcted rat myocardium stained for  
NADPH diaphorase activity. Viable tissue stains purple,  
while necrotic tissue does not stain.

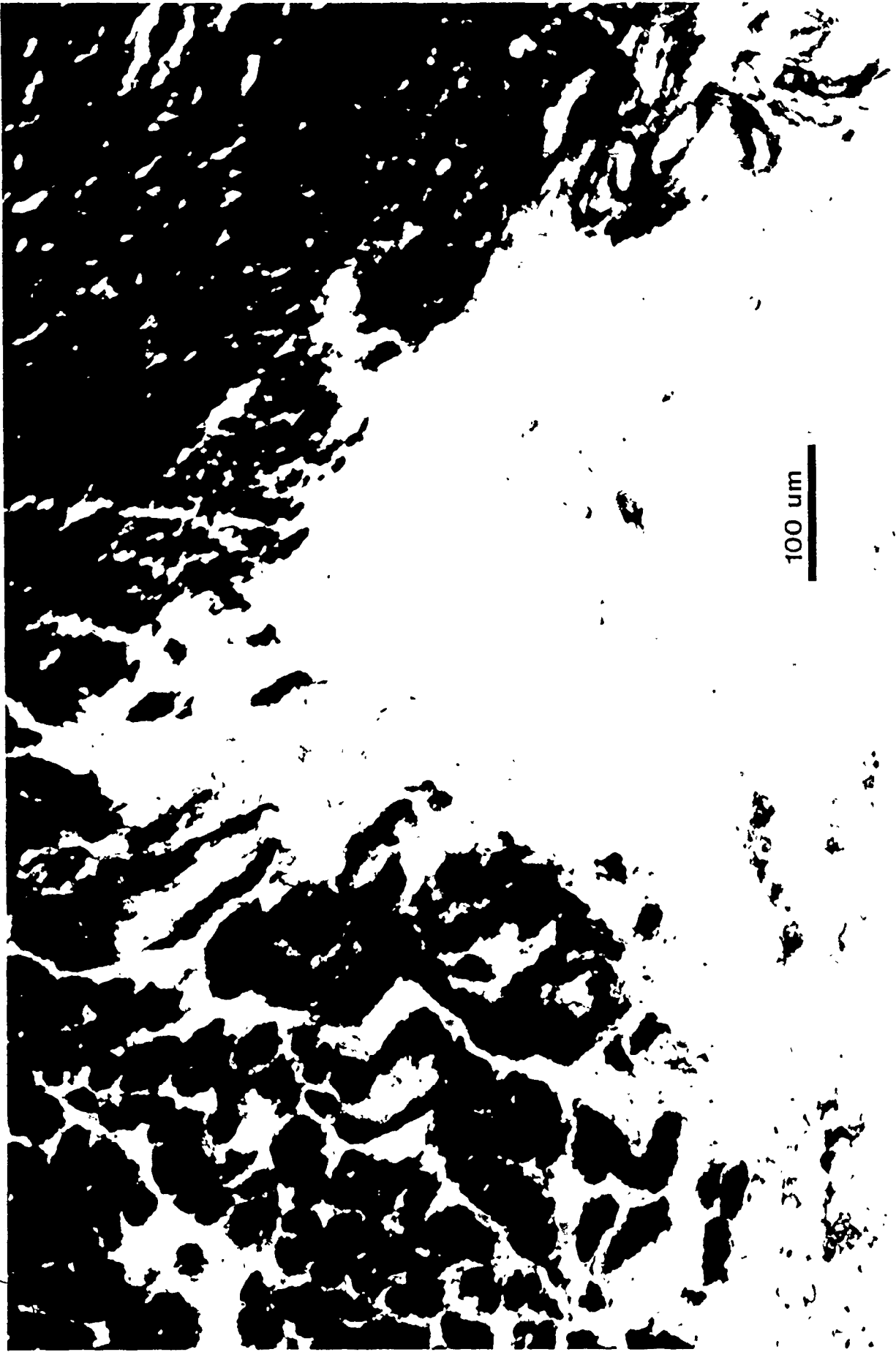
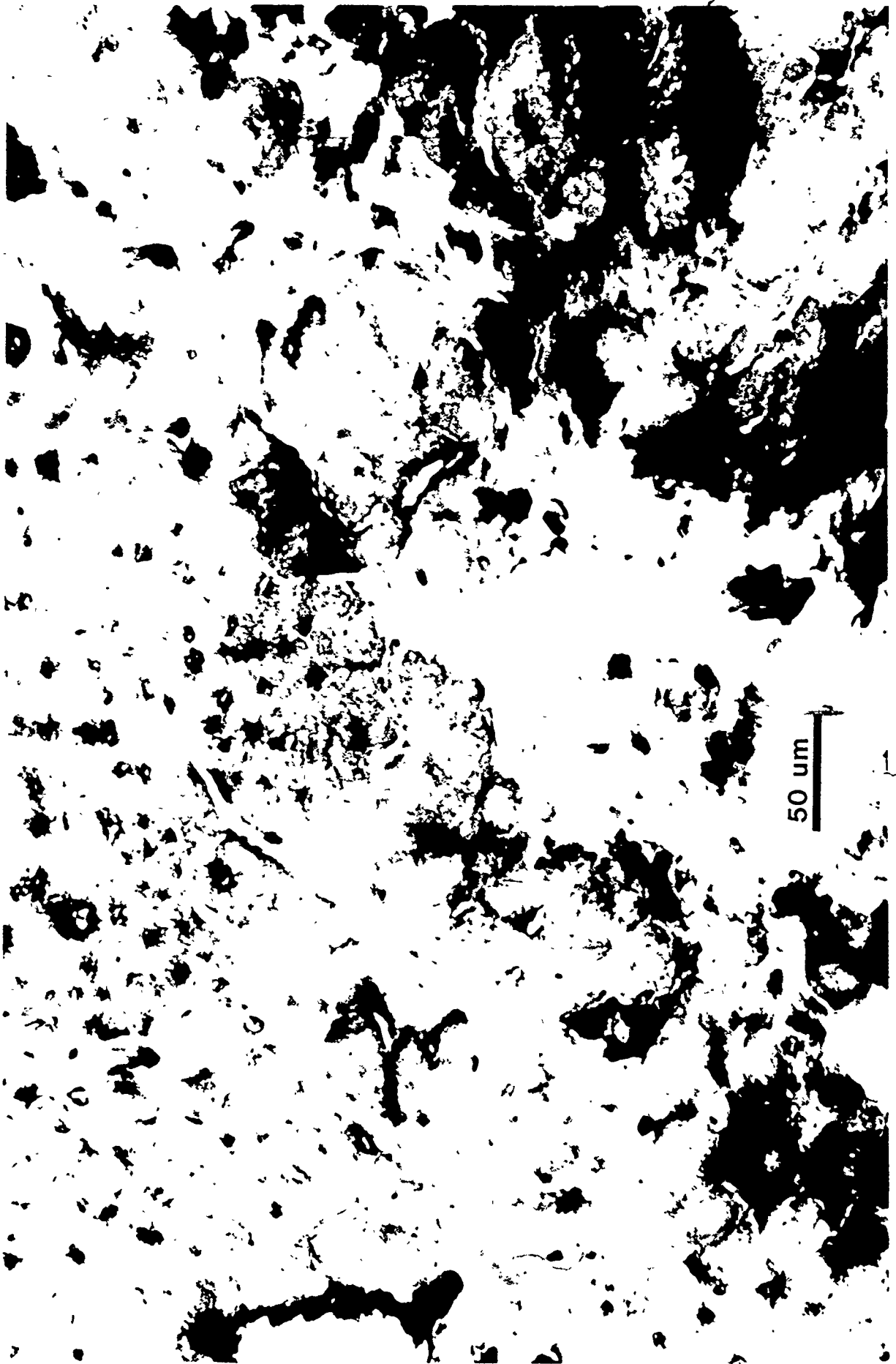

Plate 2. Cross-section of infarcted rat myocardium stained for ATPase activity, showing the capillaries (dark brown spots) and muscle fibers at the edge of the necrosis.



basis. Six variables were measured from the photomicrographs:

(1) the number of capillaries surrounding each muscle fiber - that is, vessels around a fiber, denoted by the symbol  $V_f$ .

(2) the number of fibers sharing each vessel - fibers supplied by a vessel, or  $F_v$ .

(3) the C/F (capillary to fiber) ratio. This traditional index of microvascular supply can be computed from the quotient of the capillary and muscle fiber densities (Bloor et al., 1970; Tomanek, 1970; Leon et al., 1968; Turek et al., 1978), or on a 'per fiber' basis from the quotient of the mean  $V_f$  and  $F_v$  values (Plyley and Groom, 1975; Gray and Renkin, 1978). For large sample sizes, these two methods are equivalent. I have used the latter method to calculate the C/F ratios, for reasons which will be discussed in detail later.

(4) muscle fiber diameter, measured from the photomicrographs with a pair of calipers. The mean fiber diameter for each animal was obtained from the measurement of 75 to 150 fibers selected at random.

(5) capillary density (number per  $\text{mm}^2$ ).

(6) mean intercapillary distance (again measured with calipers) obtained from the measurement of 150 pairs of capillaries chosen at random for each animal.

For the calculation of the mean values of  $V_f$ ,  $F_v$  and C/F ratio, each of the 15 to 25 fields of view was considered to be one independent sample, having its own mean and standard deviation. As the photomicrographs did not overlap, and were not taken immediately adjacent to each other, it was assumed that the capillary supply in one field of view was not dependent upon or related to the capillary supply in another field of view. The standard errors were then

calculated from the quotient of the standard deviation of the distribution of the means and (the number of fields of view)<sup>1/2</sup>.

Before the experiments themselves are presented, it is important to address two fundamental questions concerning my method of data collection and analysis:

(1) Why did I approach the question of capillary supply to the transition zone on a 'per fiber' basis, rather than asking 'how many vessels supply how many fibers'?

Most of the previous studies of capillary supply to a tissue have been based on the documentation of capillary and muscle fiber densities. The results from these measurements have been highly variable, due to:

(a) the methods used to visualize the capillaries. Infusion of the microvasculature with media such as ink, gelatin, silicone elastomer, etc. often leaves the vascular bed incompletely filled, thereby leading to an underestimate of the capillary density (Krogh, 1919; Plyley and Groom, 1975). Counting of red cells from histological cross sections can also provide inaccurate values of capillary density, as the method detects only vessels which are patent and contain erythrocytes (as opposed to plasma) (Rakusan, 1971a; Plyley and Groom, 1975; Sillau and Banchemo, 1977).

(b) tissue shrinkage. Fixation, dehydration and paraffin embedding reduce the area of tissue cross sections by approximately 56% (Plyley and Groom, 1975). If no correction for this shrinkage is made, values obtained for capillary and muscle fiber densities will be artificially high.

By using fresh, frozen tissue sections (in which the shrinkage



is negligible (Sillau and Banchemo, 1977; Drury et al., 1967)) and visualizing the capillaries and fibers histochemically, these two difficulties have been avoided (Sillau and Banchemo, 1977). However, I was also concerned about the possible lack of sensitivity involved in using a density measurement to look for changes in capillary supply within a narrow band of tissue.

If measurements are taken over a large area ( i.e. at low magnification), a subtle change in density might not be detected, as calculation of a density implies a homogeneous distribution of the capillaries or fibers throughout the area of tissue being sampled. If a small sample area is used, results may be inaccurate because of the problem of how to count capillaries and muscle fibers which fall on the edge of the field of view. This concern becomes increasingly important at high magnifications. By analysing on a 'per fiber' basis, the uncertainties associated with density measurements are not encountered.

(2) Why did I examine the variables  $V_f$  and  $F_v$ , as well as the traditional C/F ratio?

The C/F ratio for a tissue is calculated from the quotient of the capillary and muscle fiber densities, or from the quotient of  $V_f$  and  $F_v$ . By definition, a change in the C/F ratio can be due to a change in the numerator alone, the denominator alone, or some combination of the two. Similarly, the C/F ratio can remain constant if changes in the two components of the ratio cancel each other out.

While a change in the C/F ratio implies a change in the overall oxygenation of the tissue, it gives no insight into the

specific nature of the changes. Even if the data for capillary and muscle fiber densities are also provided, their meaning may be uncertain because of the inherent difficulties outlined previously. When  $V_f$  and  $F_v$ , the two constituents of the C/F ratio, are themselves examined, we begin to discern how the oxygen supply to the muscle fibers has changed.

$V_f$  (vessels around a fiber) is an index of the absolute number of capillaries available to supply each muscle fiber. An increase or decrease in mean  $V_f$  represents the growth of new vessels, or the regression of previously existing capillaries.  $F_v$  (fibers sharing a vessel), however, is a measure of the relative capillary-fiber geometry. That is, a change in mean  $F_v$  indicates a shift in the relative positions of capillaries and muscle fibers, such that each fiber receives a fractionally larger or smaller portion of the available oxygen from each capillary. Assuming that each capillary is supplied by the capillaries adjacent to it, the oxygen and nutrient supply of the fiber clearly depends on both the number of capillaries present (measured by  $V_f$ ) and their positions with respect to the fiber (provided by  $F_v$ ).

CHAPTER FOUR: Characterization of the Transition Zone  
in the Chronically Infarcted Rat Heart.

As mentioned in the general introduction, the first objective of my thesis was to ascertain whether or not a transition zone is present in an animal model of chronic myocardial infarction. This chapter presents my evidence for the presence of a transition zone in the rat heart, five weeks following coronary artery occlusion. In addition, an estimate of the width of the border zone and a discussion of oxygen supply to the muscle fibers in this region is included.

#### 4.1 Microvascular Evidence for a Transition Zone

##### 4.1.1 Protocol

Myocardial infarcts were induced in seven healthy male Wistar rats ( $199 \pm 26$  gm S.D.), using the method for left coronary artery occlusion described in the previous chapter. Sham operations were performed on an additional two rats ( $211 \pm 1$  gm). The procedure for the sham operation was identical to that used for the MI's, except the ligature around the LCA was not tightened. For the purpose of brevity, rats with a myocardial infarction will be referred to as "MI's"; similarly, those having undergone sham operations will be referred to as "SO's".

Five weeks after the surgery, the MI's and SO's were killed and the hearts processed. For the MI's, the microvascular supply to the muscle fibers adjacent to the scar was quantified. Only focal points of necrotic tissue, where the ligature had passed through the myocardium, were detected in the SO's; sections cut through this area were used for the analysis.

To determine whether the capillary supply adjacent to the

lesion differs from that found in normal hearts; five healthy male Wistar rats were used as controls. For these animals, sections were cut through regions of the heart comparable to those sampled in the two experimental groups, and stained for capillaries using the ATPase method.

#### 4.1.2 Results

In all rats studied, the observed values of  $V_f$  (vessels surrounding a muscle fiber) ranged from zero to six (figure 6). For the control animals, the range in  $V_f$  values approximated a symmetrical distribution, with a mode of three and a mean of  $3.03 \pm 0.02$  (S.E.M.) (figure 6 and table 2). Results for the sham operated group did not differ significantly from those of the controls (mean  $V_f = 2.91 \pm 0.04$ ). In contrast, the distribution of  $V_f$  values for the MI's was skewed to the left with respect to the controls, having a mode of two and a mean of  $2.34 \pm 0.07$  (figure 6 and table 2). This reduction in mean  $V_f$  for the fibers at the margin of the lesions was statistically significant ( $p < 0.005$ ).

In all three groups of animals, the values of  $F_v$  (fibers sharing a vessel) always ranged from one to five (figure 7). For the controls, the mean  $F_v$  was  $2.72 \pm 0.01$  (table 2), and the mode of the distribution was three. As was the case with  $V_f$ , the distribution of  $F_v$  values for the MI's was skewed to the left, with a mean of  $2.54 \pm 0.03$  and a mode of two (figure 7 and table 2). This difference again proved to be significant, with  $p < 0.005$ . No significant difference in mean  $F_v$  was observed, however, between the controls and the SO's (mean  $F_v = 2.74 \pm 0.04$ ).

As can be expected, similar trends were observed when the C/F

Figure 6: Frequency distribution of  $V_f$  values in

 controls (n=5)

 SO's (n=2)

 the transition zone of MI's, 5 weeks following occlusion of the left coronary artery (n=7)

\*  $p < 0.005$

■  $p < 0.025$

▲  $p < 0.050$

with respect to the corresponding control value, as determined by a standard t-test.

Error bars denote standard deviation about the mean.

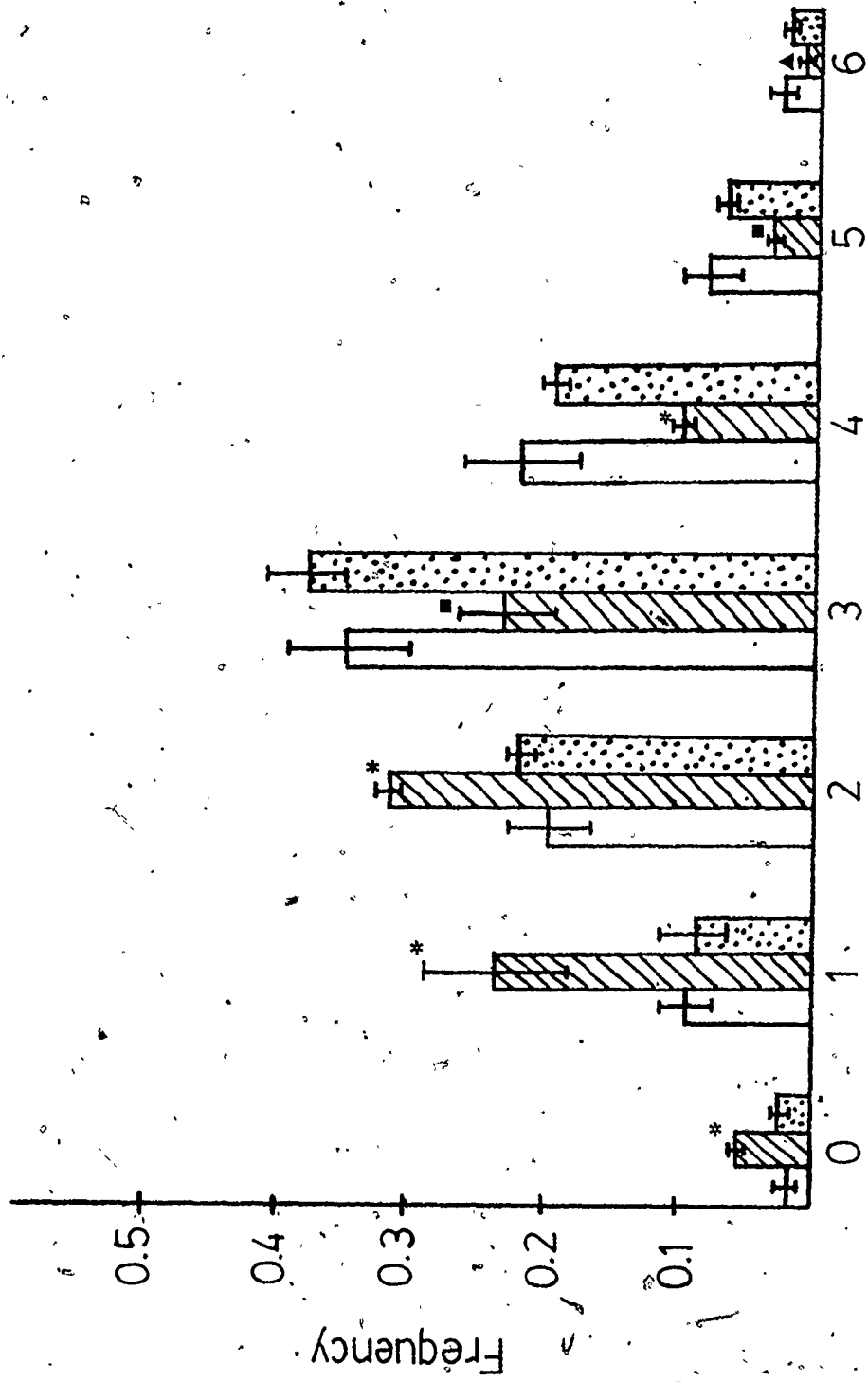

Vf

Figure 7: Frequency distribution of  $F_v$  values in

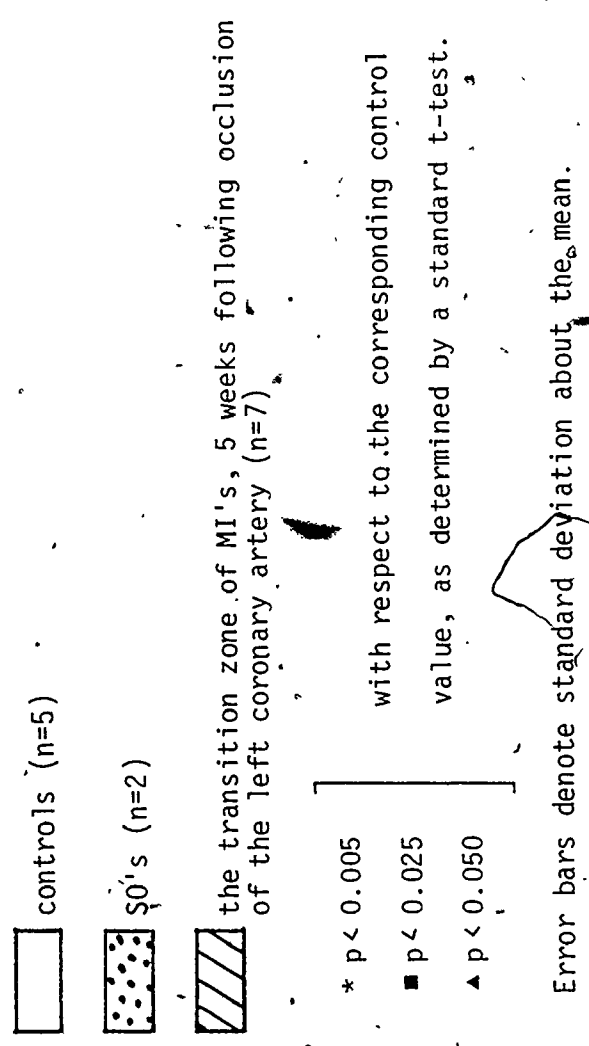



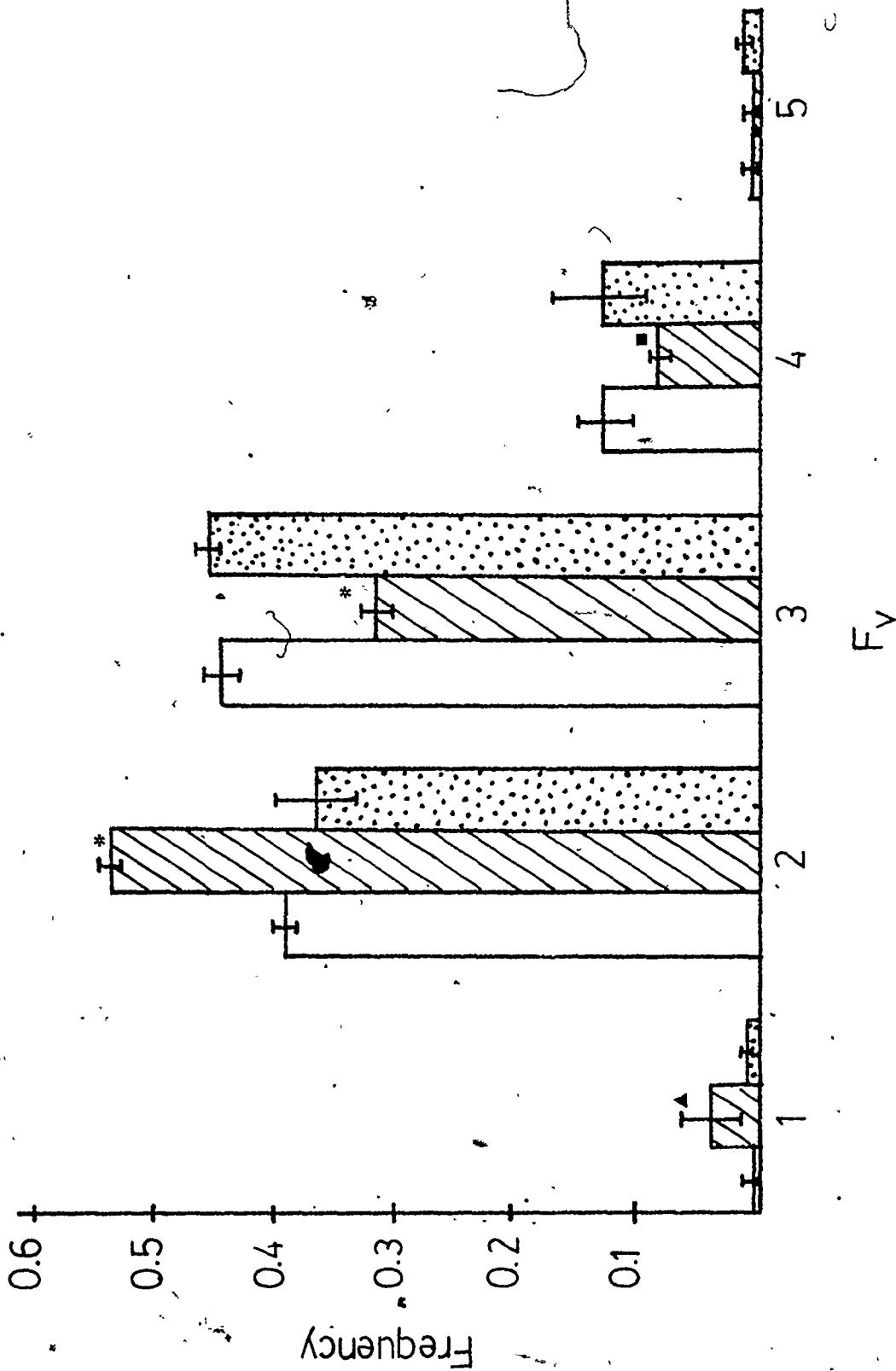

Table 2

$V_f$  (vessels around a fiber),  $F_v$  (fibers sharing a vessel), C/F ratio, fiber diameter, capillary density and intercapillary distance in controls, SO's, and in the transition zone of MI's, 5 weeks following coronary artery occlusion.

	Controls (n=5)	MI's (n=7)	SO's (n=2)
$V_f$	$3.03 \pm 0.02$	$2.34 \pm 0.06$ *	$2.91 \pm 0.04$
$F_v$	$2.72 \pm 0.01$	$2.52 \pm 0.02$ *	$2.72 \pm 0.04$
C/F ratio	$1.11 \pm 0.01$	$0.92 \pm 0.02$ *	$1.06 \pm 0.02$
Fiber diameter ( $\mu\text{m}$ )	$16.38 \pm 3.21$	$17.33 \pm 2.89$	
Capillary density ( $\#/\text{mm}^2$ )	$2,196 \pm 223$	$1,705 \pm 242$ †	
Intercapillary distance ( $\mu\text{m}$ )	$13.31 \pm 2.21$	$13.71 \pm 2.77$	

\*  $p < 0.005$  with respect to control

†  $p < 0.010$  with respect to control

as determined by a

standard t-test.

ratios for the controls, MI's and SO's were compared (table 2).

The mean C/F ratio for the MI's ( $0.92 \pm 0.02$ ) was significantly less ( $p < 0.005$ ) than the C/F ratio for the controls and the SO's ( $1.11 \pm 0.01$  and  $1.06 \pm 0.01$  respectively).

In addition, a trend toward larger mean muscle fiber diameters and greater intercapillary distances was also noted in the transition zone of the MI's, but these differences were not significant. There was, however, a significant reduction in capillary density ( $p < 0.010$ ) in the MI group. These results are also summarized in table 2.

#### 4.1.3 Discussion

I have found that muscle fibers in the transition zone are characterized by:

- (1) fewer capillaries around each muscle fiber (i.e. lower mean  $V_f$  value).
- (2) fractionally fewer muscle fibers sharing each remaining capillary (i.e. reduction in mean  $F_v$ ).
- (3) a lower capillary density and C/F ratio.
- (4) a trend toward fiber hypertrophy and greater intercapillary distances.

Clearly the microvascular supply in this region is subnormal; thus, the experiment provides evidence for the presence of a transition zone in the chronically infarcted rat heart. Although by definition this does not represent a classical 'border zone', it does represent an area of tissue which, in terms of its microvasculature, is in an intermediate state - not normal but also not necrotic.

It is difficult to compare these results to data documented in the literature. To my knowledge, only one study of capillary supply

in rat hearts following chronic MI has been performed (Turek et al., 1978), and measurements of  $V_f$  and  $F_v$  were not included. It is encouraging to note, however, that my values for capillary density in healthy rat left ventricle are in good agreement with the findings of other authors (refer to table 1), if one considers:

(1) differences in methods of tissue processing and visualizing the capillaries. (i.e. In other studies, capillaries were filled with an injection medium and/or the hearts were fixed in formalin and embedded in paraffin. The shortcomings of these methods have been discussed previously.)

(2) the fact that capillary density in the heart is inversely proportional to the heart weight (Hudlicka, 1982); thus, the age of the animal determines to some extent its myocardial capillary density.

Turek et al. (1978) determined the capillary and muscle fiber densities, mean fiber diameters and C/F ratios in rats 32 days following ligation of the left coronary artery. Their values for capillary density in the left ventricles of both healthy rats and MI's were slightly greater than what I observed. This could be explained by the fact that Turek et al. (1978) fixed and embedded their tissues before staining histochemically for the presence of capillaries. Turek et al. (1978) noted a 23% decrease in capillary density in the left ventricles of his MI group; this is in complete agreement with my findings (I observed a difference of 22%). Thus, while our actual density measurements differed somewhat, the overall trends observed were the same.

No significant decrease in C/F ratio was demonstrated by Turek et al. (1978) in the MI's; this is in contrast to my own findings.

Their results showed a significant increase in mean muscle fiber diameter and intercapillary distance in the infarcted hearts. Hypertrophy of the muscle fibers (thereby lowering the fiber density) was proportional to the decrease in capillary density; thus, no change in C/F ratio was obtained. I observed a much smaller per cent decrease in mean fiber diameter than did Turek et al. (1978). Since this was accompanied in my study by a substantial decrease in the absolute number of capillaries, a significant reduction in C/F ratio was obtained for my MI group.

It may not be totally valid to compare my results with those of Turek et al. (1978) because of two important differences in protocol:

(1) I ligated the left coronary artery midway along its course, while Turek et al. (1978) occluded the vessel "close to its origin". This would produce a lesion which occupies a greater percentage of the left ventricular wall. If the necrotic zones were very large, it is possible that the remaining viable fibers had to exert a greater contractile force to maintain adequate cardiac output. This may explain the significant increase in muscle fiber diameter observed in the study of Turek et al. (1978) but not in my own.

(2) Turek et al. (1978) did not appear to restrict his measurements to the region immediately adjacent to the lesion; rather, the samples were taken wherever the tissue was not necrotic. If, as suggested previously, the area of the scar was very large, it is possible that the small amount of remaining tissue was in fact the transition zone.

To summarize, I observed a significant decrease in mean  $V_f$  in the transition zone. This can only be interpreted as a reduction in the total number of capillaries available to supply the fibers

in this region. This conclusion is supported by the fact that capillary density in the transition zone was also observed to be significantly below normal. A reduction in the absolute number of capillaries would contribute to the trend toward an increased mean intercapillary distance which was also noted (i.e. if fewer capillaries are present in the same unit area, the average distance between them will probably be greater). One could ask how the muscle fibers in the transition zone can remain viable when their capillary supply has been reduced by approximately 25%. In fact, 25% to 50% of the capillaries in the heart are not perfused when the animal is at rest (Henquell et al., 1976); thus, a 25% reduction in the number of capillaries would not be expected to affect the survival of the fibers unless the metabolic demand of the heart is increased.

In addition, I found a significant reduction in mean  $F_V$  in the region adjacent to the necrosis. As mentioned previously,  $F_V$  is an index of capillary-fiber geometry; thus, a decrease in mean  $F_V$  represents a change in this geometry such that each of the fibers tends to be supplied by fractionally fewer of the remaining capillaries. That is, each capillary tends to supply two fibers rather than three. The interesting concept arising from this result is that the capillary bed of the myocardium is labile and dynamic, rather than a fixed, static structure. Perhaps this decrease in mean  $F_V$  in the transition zone is a safety mechanism to protect these fibers from hypoxia. It implies that the fibers can each obtain a fractionally larger amount of oxygen from the remaining capillaries - i.e. since each capillary supplies an average of two fibers rather than three, each fiber can receive one half rather than one third of the oxygen from that capillary.

In light of the current controversy dealing with the presence of a border zone in acute myocardial infarction, it seems reasonable to ask what type of vascular anatomy could have lead to the observed changes in the values of  $V_f$  and capillary density in the transition zone. I believe there are three possible explanations:

(1) the region of myocardium which evolved into the transition zone was supplied by arterioles, arising from different arteries or arterial branches, which were interconnected. Thus, while one portion of the left coronary artery was occluded, collateral flow from the right coronary artery or branches of the left coronary artery proximal to the ligature was sufficient to perfuse 75% of the capillaries (those which did not die) and maintain the muscle fibers in this region.

(2) the myocardial capillary beds are not interconnected, but do interdigitate extensively. If 75% of the capillaries in the area destined to become the transition zone arose from a vessel other than the left coronary artery, they would not be affected by its occlusion; thus, would still be perfused. Similarly, 25% of the capillaries were supplied by the left coronary artery distal to the ligature, and did not survive.

(3) The myocardial capillary beds are not interconnected and do not interdigitate. This arrangement seems to preclude the presence of a border zone in acute MI. Perhaps, however, the transition zone can be explained by the growth of capillaries from the normally perfused vessel toward the developing necrosis in the early stages following coronary artery occlusion.

Using my methods, it is not possible to discern which of these

vascular arrangements describes the situation in healthy rat myocardium. Intuitively I find it difficult to believe, however, that capillary beds arising from different arteries or arterial branches are completely independent of each other, as is suggested by the third explanation.

#### 4.2 Width of the Transition Zone

While my data demonstrates the presence of a transition zone adjacent to the necrosis, it gives no information about the size of the region. Measurement of the width of the transition zone is important for two reasons:

(1) it indicates how much of the myocardium has a sub-normal microvascular supply.

(2) the size of the region must be considered when choosing an appropriate magnification to photograph the fields of view. i.e. Have I sampled only the transition zone, or is the test area wider than the region of interest and therefore 'contaminated' with control tissue?

##### 4.2.1 Protocol

Composite photomicrographs at low magnification (50x), extending radially outward from the necrosis, were compiled for two of the seven MI's, five weeks following left coronary artery occlusion. As I wanted to measure the change in capillary supply as a function of distance from the necrosis, the photomicrographs were taken from the ATPase sections.

On the composites, concentric bands were drawn parallel to the margin of the necrosis (figure 8). Each band corresponded to a tissue width of 75 $\mu$ m - approximately five muscle fibers in thickness.



Figure 8: Schematic illustration of the method of sampling capillary density as a function of radial distance from the edge of the necrosis.

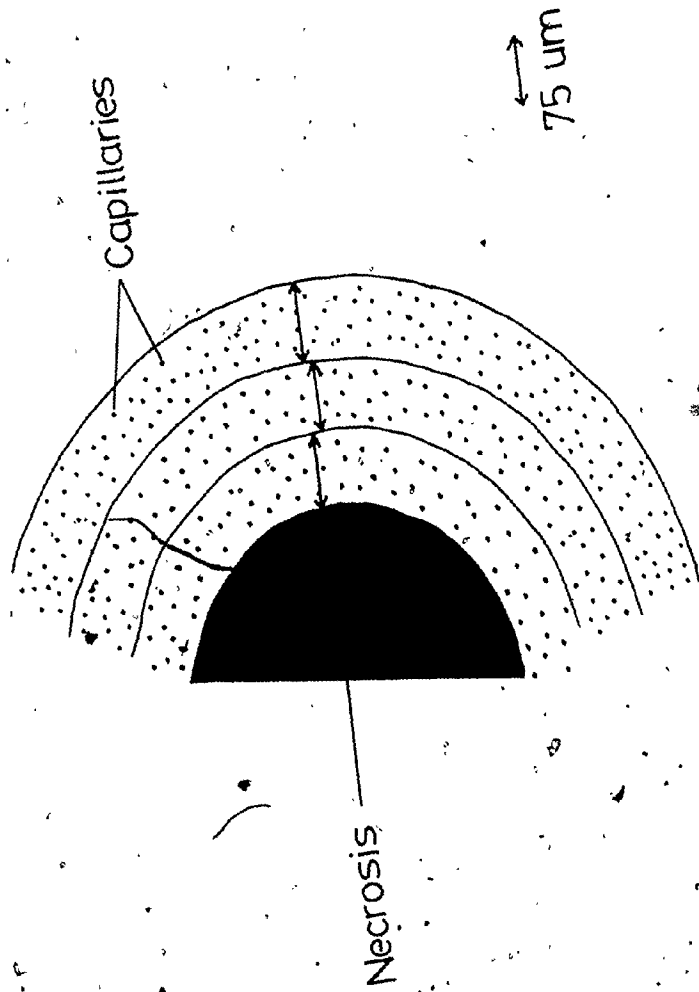

The number of capillaries in each band was counted and divided by the area of the band, providing a measure of capillary density for each region. It should be mentioned that capillaries on the boundary of a band were counted if half their area (estimated visually) fell in that band; if not, they were included in the subsequent region. I chose to measure capillary density from these photomicrographs, because at a magnification of 50x I felt that measurements of  $V_f$  and  $F_v$  could not be made accurately.

#### 4.2.2 Results

Figure 9 shows the variation in capillary density as a function of increasing radial distance from the edge of the necrosis. Capillary density appears to remain relatively constant at approximately 1,600 per  $\text{mm}^2$  over the initial 225  $\mu\text{m}$  from the edge of the lesion; beyond this point, the density values gradually increase and reach a plateau of approximately 2,300 per  $\text{mm}^2$  at a radial distance of 525  $\mu\text{m}$ . Values of capillary density differ significantly from the control value of  $2,196 \pm 223$  per  $\text{mm}^2$  (S.D.) for the first 375  $\mu\text{m}$  from the margin of the lesion. Thus, it seems that the transition zone, measured five weeks after coronary artery occlusion, has a width of at least 375  $\mu\text{m}$ .

#### 4.2.3 Discussion

From these radial measurements of capillary density, a value of approximately 2,300 per  $\text{mm}^2$  was reached at a distance of 525  $\mu\text{m}$  from the edge of the scar. This is slightly higher than the control value of 2,196 per  $\text{mm}^2$  measured previously in the five healthy rat hearts, but the two measurements do not differ significantly. This minor discrepancy may be due to the different sampling areas used in

Figure 9: Capillary density as a function of distance from the edge of the necrosis.

- \*  $p < 0.005$
- +  $p < 0.010$
- $p < 0.025$
- $p < 0.100$

with respect to the control value of  
 $2,196 \pm 223$  per  $\text{mm}^2$  found in healthy rat hearts.

Error bars denote standard deviation about the mean.

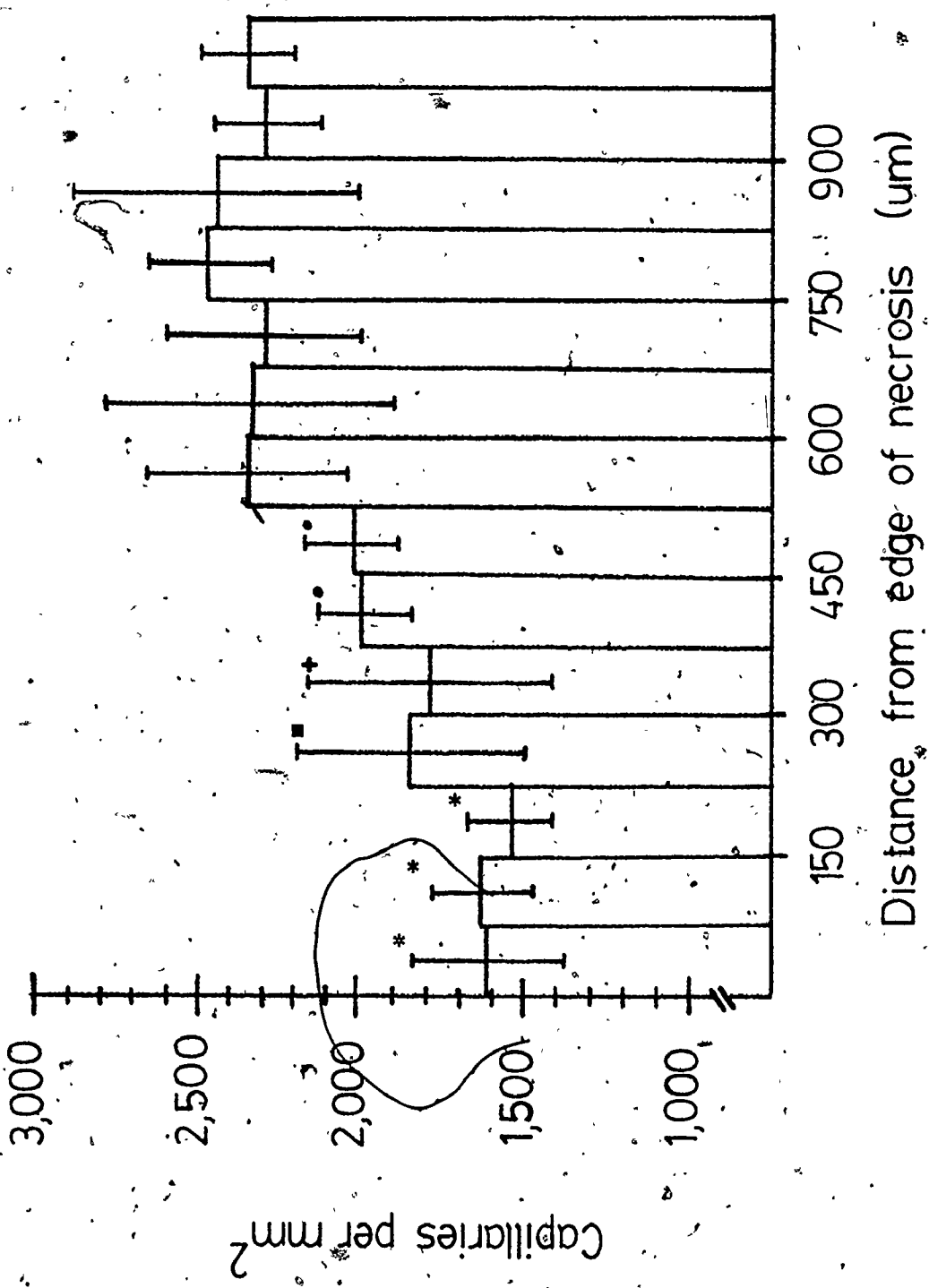

the two cases. For the controls, capillaries were counted from large (8.5" x 11") photomicrographs taken at high (150x - 300x) magnification. The composites, however, were taken at low (50x) magnification, and the measurements made from thin (4 cm) strips drawn on the photographs. The probability of errors associated with edge effects would be greater in the latter case, and may account for the two slightly different density values.

I have estimated the width of the transition zone to be a minimum of 375  $\mu\text{m}$ . Measurements of  $V_f$ ,  $F_v$ , C/F ratio, etc. for the MI's were made from photomicrographs taken at a magnification of 150x to 300x. Most (approximately 90%) of the photomicrographs were taken at a magnification of 200x; at this magnification, the width of the tissue sampled extends approximately 200  $\mu\text{m}$  from the edge of the necrosis. Thus, the measurements were taken well within the transition zone, and 'contamination' from the normally perfused myocardium is not likely.

To my knowledge, only one other study has measured the extent of the transition zone in chronic MI's. Cox et al. (1968) measured the area of intermediate tissue damage, as detected by dehydrogenase staining, from one hour to 40 days following ligation of the left anterior descending coronary artery in dogs. He found that the area of ischemic damage decreased as the necrosis evolved, and by 40 days after coronary artery occlusion no region of intermediate damage could be discerned. This appears to contradict my findings, but it must be remembered that my measurements were based on a difference in capillary supply between the transition zone and normally perfused myocardium. As has been mentioned previously, different variables

used to measure the extent of the border zone may have boundaries which are not superimposable. In fact, I could detect only two zones of tissue in my sections stained for NADPH diaphorase activity - that which stained positively for oxidative enzyme activity, and that which did not (the necrosis). Thus, I also did not observe a region of intermediate tissue damage, based on diaphorase activity, five weeks following occlusion of the artery.

#### 4.3 Implications of the Reduced Capillary Supply on Tissue Oxygenation

I have found that a transition zone, defined as a region of viable muscle fibers with a sub-normal microvascular supply, is present as long as five weeks following coronary artery occlusion in the rat. One could ask whether this statistically significant reduction in capillary supply within the transition zone has any physiological significance in terms of oxygen delivery to that region of tissue. Since a direct measurement of tissue  $pO_2$  is technically very difficult in the beating heart (Rakusan, 1971b), it is necessary to resort to a mathematical approximation.

##### 4.3.1 The Krogh Cylinder Model

Tissue  $pO_2$  is primarily determined by six factors (Rakusan, 1971b):

- (1) arterial oxygen content.
- (2) the rate of blood flow.
- (3) the internal diameter of the capillaries.
- (4) the rate at which the tissue consumes oxygen.
- (5) the distance through which the oxygen must diffuse.
- (6) the ease with which the oxygen diffuses through the tissue.

The relationship between these variables was first defined in 1919 by August Krogh in the Krogh-Erlang Equation (figure 10):

$$\Delta P = P_x - P_0 = \frac{M}{K} \left[ \frac{R^2}{2} \ln \left[ \frac{x}{r} \right] - \frac{x^2 - r^2}{4} \right]$$

where:

$P_x$  = tissue  $pO_2$  at a point 'x' in the tissue (mm Hg).

$P_0$  = capillary  $pO_2$  (mm Hg).

M = rate of oxygen consumption (ml  $O_2$ /ml tissue/minute).

K = oxygen conductivity (ml  $O_2$ /l  $cm^2$ /minute at a pressure gradient of 1 mm Hg/cm).

x = radial distance from the point 'x' in the tissue cylinder to the center of the supplying capillary (cm).

R = tissue cylinder radius (cm).

r = internal capillary radius (cm).

The Krogh Model assumes (Rakusan, 1971b; Fletcher, 1977):

- (1) the tissue cylinder is homogeneous.
- (2) blood is a homogeneous fluid with oxygen diffused uniformly throughout.
- (3) capillaries run parallel to each other for long distances, so that the capillary bed can be described by cylindrical geometry.
- (4) blood flow through the capillaries is uniform and cocurrent.
- (5) oxygen consumption in the tissue is uniform, both spatially and temporally.

In addition, the Krogh Model neglects the effects of (Rakusan, 1971b; Fletcher, 1977):

- (1) changes in oxygen concentration within or along the length

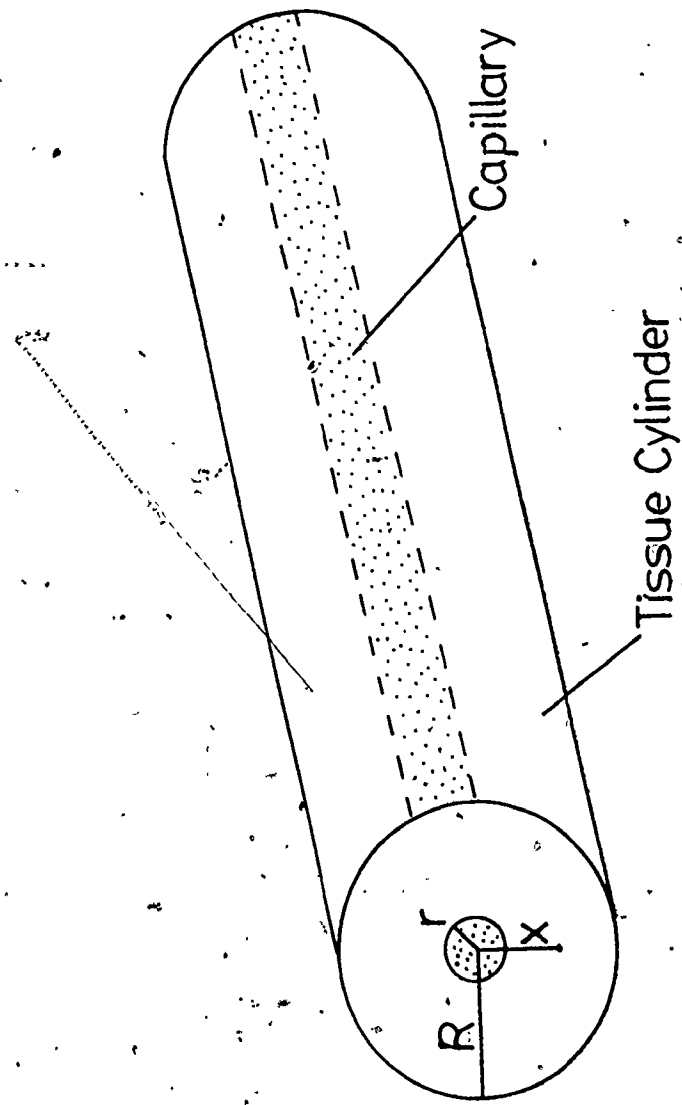

Figure 10: Definition of variables used in the Krogh Cylinder Model

$R$  = tissue cylinder radius.

$r$  = capillary radius.

$x$  = radial distance from the center of the nearest capillary to the point "x" in the tissue cylinder.



of the capillary.

- (2) axial and facilitated diffusion.
- (3) temporal or spatial changes in oxygen conductivity.
- (4) the presence of myoglobin in the tissue.

#### 4.3.2 Calculations and results

I used the Krogh Model to estimate the effect of the reduced capillary supply in the transition zone on the potential for oxygen delivery, under conditions of both normal and increased (1.5x) myocardial oxygen consumption. Values of  $M$  (metabolic rate),  $K$  (oxygen conductivity) and  $r$  (capillary radius) for rat heart were obtained from the literature, and assumed to be the same for both the transition zone and normally perfused myocardium.  $R$  (tissue cylinder radius) was calculated from my capillary density data, using Thews' Model of diffusion distance (Rakusan, 1971b):

$$R = \left[ \frac{2A}{3\sqrt{3} n} \right]^{1/2}$$

where:  $n$  = number of capillaries

$A$  = area in  $\text{mm}^2$

$A/n$  = (capillary density) $^{-1}$

Values of the variables used in the Krogh Cylinder Calculation and their sources are listed in table 3.

Plots of the tissue  $pO_2$  gradients as a function of radial distance from the center of the capillary for the controls and MI's are shown in figures 11 and 12 respectively. For the plots,  $P_0$  (capillary  $pO_2$ ) was assumed to be 25 mm Hg, corresponding to the venous end of the capillary network. As the tissue cylinder radius defines the extent of tissue which each capillary is responsible for supplying, all the tissue is assumed to be receiving oxygen if

Table 3

M (rate of myocardial oxygen consumption), K (oxygen conductivity), r (capillary radius) and R (tissue cylinder radius) in healthy rat myocardium, and in the transition zone of MI's, 5 weeks following coronary artery occlusion.

	MI	Control	Reference
M (ml O <sub>2</sub> /gm/min)	0.39	0.39	Martini et al. (1974)
K (ml O <sub>2</sub> /cm/min)	$2.5 \times 10^{-8}$	$2.5 \times 10^{-8}$	Thews (1967)
r (cm)	$3.0 \times 10^{-4}$	$3.0 \times 10^{-4}$	Steinhausen et al. (1978)
R (cm)	$15.05 \times 10^{-4}$	$13.23 \times 10^{-4}$	

Figure 11: Tissue  $pO_2$  in healthy rat myocardium, calculated using the Krogh Model, as a function of radial distance from the center of the nearest capillary. Capillary  $pO_2$  is assumed to be 25 mm Hg, corresponding to the venous end of the network.

———— resting myocardial oxygen consumption  
- - - - - 1.5x resting myocardial oxygen consumption

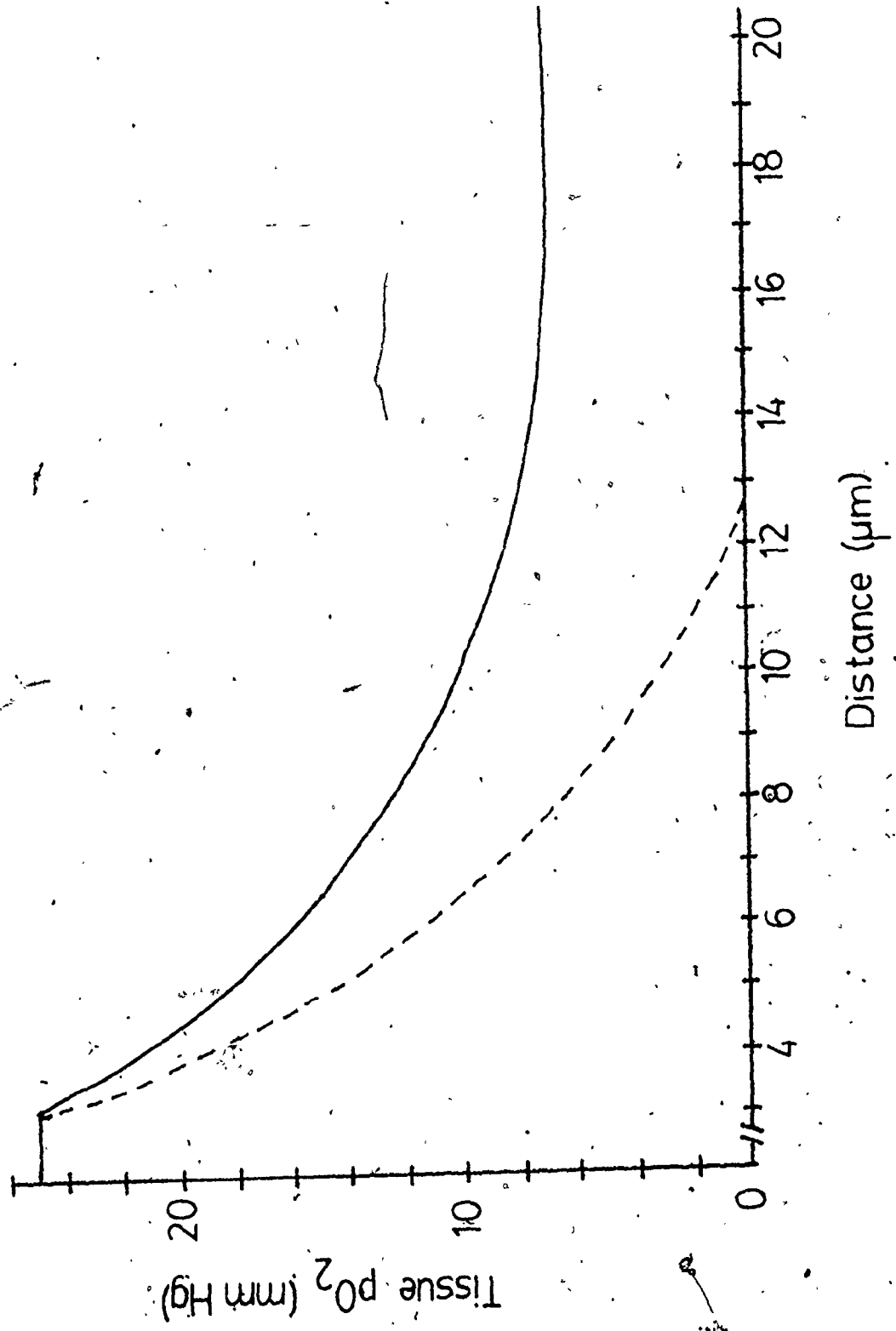
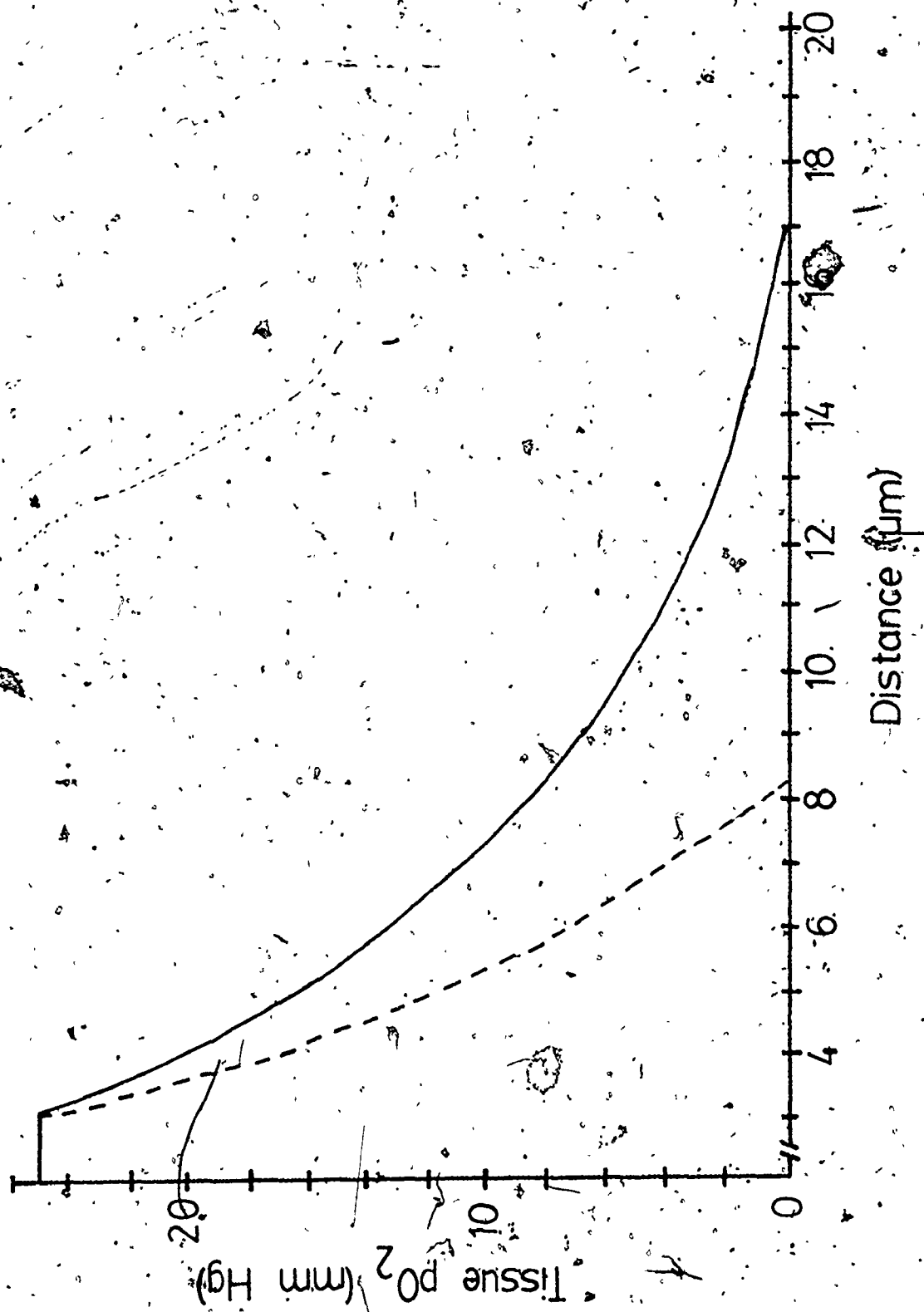

Figure 12: Tissue  $pO_2$  in the transition zone, calculated using the Krogh Model, as a function of radial distance from the center of the nearest capillary. Capillary  $pO_2$  is assumed to be 25 mm Hg, corresponding to the venous end of the network.

———— resting myocardial oxygen consumption.  
- - - - - 1.5x resting myocardial oxygen consumption.





2

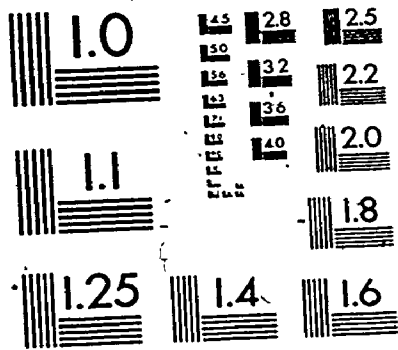

$pO_2 > 0$  at  $x \leq R$ . If the  $pO_2$  drops to zero at a distance  $x_1 < R$ , this implies that the tissue  $x_1 < x < R$  is anoxic.

Under normal conditions of oxygen consumption, the Krogh Model predicts that both the normal myocardium and the transition zone of the MI's are in no danger of becoming anoxic. Tissue  $pO_2$  in the transition zone falls to zero at a radial distance of approximately 17  $\mu\text{m}$ , but since  $R$  for the MI's equals 15.05  $\mu\text{m}$ , all the tissue in this region appears to be receiving oxygen.

If the rate of oxygen consumption is raised by a factor of 1.5x, the healthy myocardium still appears to be supplied with oxygen. In the transition zone, however,  $pO_2$  drops to zero at an approximate distance of 8  $\mu\text{m}$ , 7  $\mu\text{m}$  short of the edge of the tissue cylinder radius. This predicts that the tissue at the midpoint between capillaries (at the outer bounds of adjacent tissue cylinders) is anoxic.

#### 4.3.3 Discussion

The Krogh Model assumes "... the microcirculation is a passive network of tubes supplying blood to a noninteracting volume of tissue that has a specific metabolic function" (Fletcher, 1977). This is an oversimplification, especially in the beating heart.

Every mathematical model makes assumptions which are known to be physiologically incorrect. When the Krogh Model is applied to the heart, three of these inherent assumptions are false (Rakusan, 1971b; Fletcher, 1977):

(1) both blood flow and oxygen consumption are not constant in the heart, but vary with the cardiac cycle. There is an increase in coronary blood flow and decrease in oxygen consumption during diastole;

the reverse is true in systole.

(2) the myocardial capillary beds conform in general to the required cylindrical geometry, except the capillary entrances and exits are staggered.

(3) blood flow in adjacent capillaries is not always cocurrent.

From this it appears that the simple Krogh Model is not applicable to the heart. Many elaborations to the basic Krogh Model, which do not require constant flow or steady state conditions, have been developed, as well as models based on other geometrical arrangements (Fletcher, 1977). It is interesting to note, however, that these more recent, detailed and 'accurate' models (such as Metzger's "network model" and Diemer's "cone model") provide solutions which do not differ greatly from results obtained using a simple Krogh Cylinder approximation. According to Fletcher (1977), ". . . no other model proposed to date gives a significantly better correlation with existing oxygen measurements than cocurrent flow and parallel geometry".

With this in mind, I chose to use the Krogh Model to approximate oxygen delivery to the tissue, rather than attempt another more complex model. While the Krogh equation provides only a first-order approximation of tissue  $pO_2$  gradients, it is useful for predicting changes in myocardial  $pO_2$  caused by changes in its determinants (Rakusan, 1971b).

In my calculations, I have assumed that M (metabolic rate), K (oxygen conductivity) and r (capillary radius) are the same in both the transition zone and in normally perfused myocardium. I could find no information in the literature as to how K might vary in response to a decrease in microvascular supply, so it was left as a

constant.

Turek et al. (1978) observed an increase in external capillary radius in rat hearts 32 days following coronary artery occlusion: it is not clear whether this represents an increase in the luminal diameter of the capillaries, or a thicker capillary wall. They calculated that an increase in the internal capillary radius could partially counteract the effects of a larger tissue cylinder radius, (which they also observed), but certainly could not compensate for it. In my experiments, there may have been an increase in mean capillary diameter in the MIs, but I was not able to measure this from my photomicrographs. From visual observation, however, I would conclude that any such increase was minor, and would not be sufficient to return the tissue  $pO_2$  gradients in the transition zone to normal.

M, the metabolic rate, was also assumed to be the same in the transition zone and in healthy hearts; this may not be a valid assumption. Myocardial oxygen consumption is primarily determined by three interrelated factors (Guyton and Cowley, 1976): the contractile state of the heart, wall tension and heart rate. Wall tension in the left ventricle can be estimated using Laplace's Law:

$$\text{Tension} = \text{Pressure} \times \frac{\text{Radius}}{2(\text{Wall thickness})}$$

Fletcher et al. (1981) observed significant increases in both left ventricular end diastolic volume and left ventricular end diastolic pressure in rat hearts 22 to 29 days after ligation of the left coronary artery. In addition, Fishbein et al. (1978) noted significant thinning of the left ventricular wall in rats 21 days post-MI. Each

of these three factors - increased pressure, increased radius and decreased wall thickness - produces an increase in the wall tension, which may result in a change in the rate of oxygen consumption in the transition zone of the infarcted rat heart. Fletcher et al. (1981) also found an increase in the compliance of the infarcted left ventricles; this could be interpreted as a change in the contractile state of the ventricle, which would further influence the metabolic rate.

From this, it seems there may well have been a change in metabolic rate within the transition zone which was not taken into account in the calculations; however, I could find no estimate or measurement of oxygen consumption for chronically infarcted rat hearts. I was primarily interested in determining the effect of reduced capillary supply on oxygen transport in the transition zone. The Krogh equation states that  $\Delta P \propto M$  if all other factors are constant, but also states that  $\Delta P \propto R^2$  for constant M, K and r. Thus, a small decrease in capillary density (thereby increasing the tissue cylinder radius) will have a greater effect on the tissue  $pO_2$  gradient than a change in the metabolic rate. While a change in oxygen consumption will certainly influence the tissue  $pO_2$  gradient, the dominant variable in the relationship is the tissue cylinder radius.

From my calculations, I predicted that both the transition zone and healthy myocardium would have an adequate oxygen supply under normal conditions of oxygen consumption. If the metabolic rate was increased by a factor of 1.5x, portions of the transition zone were in danger of becoming anoxic. It is interesting to note that if the oxygen demand were increased much further, some of the normally

perfused myocardium would also become anoxic. It seems unusual that healthy myocardial tissue could be at risk when the demand for oxygen is increased by only 1.5x to 2x. It should be remembered, however, that the rat has a high basal metabolic rate (3x to 4x that of man), which does not have a large capacity for increase. Thus, this observation may not be unreasonable.

#### 4.4 Summary

In this series of experiments, I have found that:

(1) a transition zone, composed of viable muscle fibers with a sub-normal microvascular supply, is present five weeks following coronary artery occlusion in the rat.

(2) the transition zone extends 375 um radially from the margin of the necrotic lesion.

(3) at rest, muscle fibers in the transition zone appear to be normoxic, but when the myocardial oxygen demand is increased, some tissue at the venous end of the capillary beds may potentially be anoxic.

An intervention capable of stimulating revascularization in the transition zone would clearly be of benefit.

CHAPTER FIVE: Effects of Exercise on Capillary Supply

The capillary bed is the immature or 'embryonic' component of the circulatory system. It has the capacity for growth and change, which it exhibits in response to injury or altered metabolic state of the tissue which it serves (Zweifach, 1959).

The lability of the capillary bed in response to injury was qualitatively demonstrated in the studies of Clark and Clark (1939). In these classic experiments, transparent celluloid chambers were implanted in rabbit ears, and the microscopic details of capillary growth observed as the wound healed. They found that new vessels originated from pre-existing vascular endothelium by the process of capillary sprouting. In fact, the mode of vessel growth and lumen formation in the adult rabbit ear strongly resembled the process of capillary growth previously observed in amphibian larvae and the tadpole tail. In addition, Clark and Clark (1939) found the proliferation of the vascular endothelium to be extremely sensitive to slight alterations in ambient temperature, or changes in the pressure of the chamber on the tissue.

Another effective stimulus for capillary growth is an increase in the metabolic demand of the surrounding tissue. Such a condition is produced in both skeletal muscle and the heart in response to exercise, and evidence in support of this statement is provided in the following paragraphs. Recall that the second objective of my thesis was to determine whether or not exercise can promote capillary growth in the transition zone of MI's; the experiments described in this chapter were designed to answer this question.



### 5.1 Skeletal Muscle

It has been well documented in the literature that exercise can increase capillary density in skeletal muscles of both animals (Tittel et al., 1966; Carrow et al., 1967; Mai et al., 1970; Adolfsson et al., 1981) and man (Andersen et al., 1977; Brodal et al., 1977; Ingjer et al., 1978). For example, Adolfsson et al. (1981) observed significant increases in capillary density, C/F ratio and  $V_f$  in the quadriceps femoris after rats were forced to swim one hour per day, five days a week for three weeks.

The extent to which capillary supply in skeletal muscle increases in response to exercise appears to depend on:

(1) the age of the animal. The greatest increase in capillary supply for a given exercise protocol is observed in young or 'adolescent' animals, as opposed to adult rats (Adolfsson et al., 1981; Hudlicka, 1982).

(2) muscle fiber type. There tends to be a greater per cent increase in capillaries associated with fast twitch glycolytic fibers, rather than slow twitch oxidative fibers (Hudlicka, 1982).

Cotter et al. (1973) and Brown et al. (1976) used direct chronic stimulation of skeletal muscles to simulate exercise conditions. When low frequency (five to ten Hz) stimuli were applied to the extensor digitorum longus (a fast twitch muscle) of rabbits for eight hours per day, significant increases in C/F ratio and capillary density were observed as soon as four days after the onset of the experiment. After 28 days, capillary density had doubled. The fact that this increase in capillary supply was due to the growth of new vessels was confirmed by the identification of capillary sprouts in stimulated

muscle preparations (Myrhage and Hudlicka, 1978). Direct stimulation produced a greater increase in capillary density than generally occurs with exercise, but the observed trends are the same in both cases.

## 5.2 Myocardium

The effect of exercise on capillary supply to the myocardium has not been as thoroughly investigated. It appears, however, that some forms of exercise are effective in stimulating capillary growth in the heart.

Tomanek (1970) exercised rats on a motorized treadmill an average of 45 minutes per day, 6 days a week for 12 weeks, and examined the microvasculature of the heart by perfusing it with an ink suspension. Significant increases in both capillary density and C/F ratio were observed in the hearts of the exercised rats, when compared to the nonexercised controls. As was the case in skeletal muscle, this effect was age-dependent, the largest per cent increase in capillary supply being observed in the 'adolescent' rats. Similar studies by Jacobs et al. (1980) have confirmed these results.

Improvements in myocardial capillary density and C/F ratio were also observed when rats were subjected to daily periods of swimming (Leon et al., 1968; Bloor et al., 1970; McElroy et al., 1978; Guski, 1980; Bell and Rasmussen, 1974). As in previous studies, the age of the animal had an effect on this neovascularization; no improvements in capillary supply were observed in the 'adult' rats (Bloor et al., 1970). In addition, Leon et al. (1968) found that these increased values of capillary density and C/F ratio persisted up to 42 days after the exercise program was stopped.

Stevenson et al. (1964) estimated coronary tree size by the weight of a vinyl acetate cast of the vasculature for both control and exercised rats. A greater ratio of coronary cast weight/heart weight was obtained for the exercised animals; this is in agreement with the results of the experiments mentioned previously, but an additional observation arose from these studies. Significant increases in coronary cast weight/heart weight were found in rats that ran on a treadmill twice per week for four weeks, but no improvements were noted in animals running at the same speed five days per week for four weeks. In rats that were forced to swim, those that exercised two hours twice per week showed as great an increase in coronary tree size as those that swam for two hours, five times weekly. Another group of rats forced to swim four hours per day, five days a week, demonstrated no significant increase in the ratio of coronary cast weight/heart weight.

Guski (1980) has provided data which agree with the findings of Stevenson et al. (1964). Rats which were forced to swim a total of 45 hours in approximately 18 weeks obtained significant improvements in myocardial capillary density, while those that swam 180 hours in the same total time period showed no increase in capillary supply.

These results indicate that forced exercise can lead to an increase in the size of the coronary tree, but the heavier and more frequent the enforced exercise, the poorer was the increase in the ratio of coronary cast weight/heart weight. Thus, ". . . moderate exercise with adequate rest may benefit the heart more than heavy, frequent exercise" (Stevenson et al., 1964).

### 5.3 Exercise and Myocardial Infarction

Evidence from the literature strongly suggests that exercise, or some aspect of it, stimulates neovascularization in the heart and skeletal muscle. If this is true, then moderate exercise may be of benefit in pathological conditions associated with a reduction in capillary supply. I have shown that such a condition exists in the transition zone of rat hearts, five weeks following occlusion of the left coronary artery.

To my knowledge, no experiments dealing with the effects of exercise on microvascular supply to the heart following myocardial infarction have previously been documented. Some work, however, has been done on the protective effects of exercise administered prior to the induction of an infarct.

When rat hearts were examined histologically ~~48 hours~~ after occlusion of the left coronary artery, rats that had undergone five weeks of daily swimming prior to surgery demonstrated infarct sizes 30% smaller than those in rats which had no exercise training prior to coronary artery occlusion (McElroy et al. 1978). Darrah and Engen (1982) found that 13 weeks of daily running resulted in the "reduction or prevention" of MI, assessed hemodynamically and electrocardiographically, induced in rats by injection of 1-isoproterenol. Similarly, Riggs et al. (1977) observed reduced mortality in rats that had undergone 30 days of treadmill running prior to injection of isoproterenol. In contrast, Wexler et al. (1976) found that exercise (two weeks of swimming) only protected the hearts of 'old' rats from isoproterenol-induced MI. These studies suggest that exercise prior to MI exerts some protective influence on the heart. This may be due

to an increase in capillary supply associated with exercise (McElroy et al., 1978; Leon et al., 1968).

In the past decade, several hospitals have initiated programs of early ambulation and exercise rehabilitation in the treatment of cardiac patients. Hemodynamic and electrocardiographic variables have been measured for exercised and nonexercised cardiac patients, and the possible protective effects of exercise in preventing recurrence of MI assessed (Kentala et al., 1972; Shephard, 1979; Shephard, 1980; Kavanaugh et al., 1979; Wilhelmsen et al., 1975; Sivarajan et al., 1981). Results to this point are incomplete and inconclusive.

It is apparent that measurement of capillary supply in the infarcted human heart in response to exercise is not feasible. However, if exercise is a general stimulus for capillary growth, then its use in cardiac rehabilitation could be of considerable importance. The second objective of my research was to use my animal model to determine whether exercise following coronary artery occlusion can stimulate revascularization in the transition zone.

#### 5.3.1 Protocol

Myocardial infarcts were induced in 17 healthy young male Wistar rats ( $187 \pm 18$  gm SD), using the method described previously. A one week recovery period was allowed before the experiment was continued. Then for a period of four weeks, the rats were placed individually in Wahmann activity cages two hours per day, six days a week, and left to run on a voluntary basis. That is, the cages were not motor-driven. Daily revolutions were recorded and converted to linear distances run, and the total distance run by each rat at the end of the four week period was then determined. For the sake of

brevity, these animals are referred to as "exercised MI's" throughout the text.

Five weeks after the initial surgery, the animals were sacrificed and the hearts frozen, sectioned and stained. Photomicrographs of the transition zone were taken from the ATPase sections, and used to determine mean values of  $V_f$ ,  $F_v$  and C/F for each animal.

### 5.3.2 Results

Values of  $V_f$ ,  $F_v$  and C/F ratio in the transition zone of the exercised MI's all fell between those of the MI's and controls, described in the previous chapter. Mean values of the three variables for each animal were considered as a function of total distance run at the end of the four weeks of exercise (figures 13, 14 and 15), to determine whether there was a relationship between the amount of exercise done by the rat and the capillary supply to the transition zone.

Rats that ran a total distance of between 5,000 and 10,000 meters during the four weeks had values of  $V_f$ ,  $F_v$  and C/F in the border zone which did not differ significantly from the control values of  $3.03 \pm 0.02$ ,  $2.72 \pm 0.01$  and  $1.11 \pm 0.01$  respectively. In fact,  $V_f$  and C/F returned to 95% of their control values at a total distance run of approximately 8,000 meters (figures 13 and 15), while  $F_v$  returned to 100% of its normal value at a distance of 6,000 meters (figure 14). By running a total distance of between 5,000 and 10,000 meters in four weeks, these animals restored a normal capillary supply to the muscle fibers in the transition zone.

In contrast, rats that ran less than 5,000 meters or more than 10,000 meters showed no significant improvement in mean  $V_f$ ,  $F_v$  or C/F

Figure 13: Mean  $V_f$  in the transition zone as a function of total distance run, for rats exercised 6 days/week x 4 weeks following coronary artery occlusion.

\*  $p < 0.050$  with respect to the MI value of  $2.34 \pm 0.06$ , determined by comparison to the cumulative normal distribution for the MI's. Error bars denote standard errors of the mean.

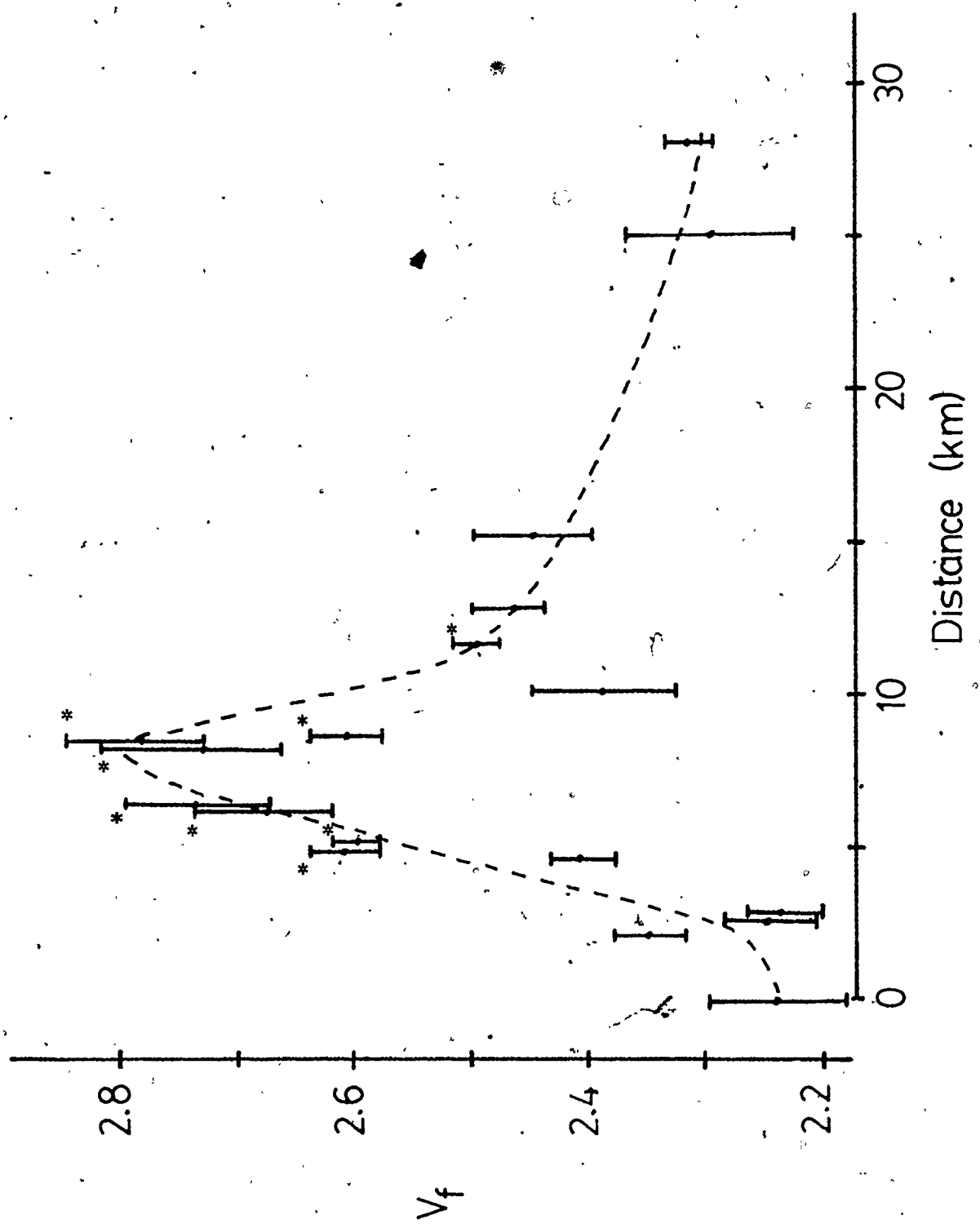



Figure 14: Mean  $F_v$  in the transition zone as a function of total distance run, for rats exercised 6 days/week x 4 weeks following coronary artery occlusion.

\*  $p < 0.050$  with respect to the MI value of  $2.52 \pm 0.02$

Error bars denote standard errors of the mean.

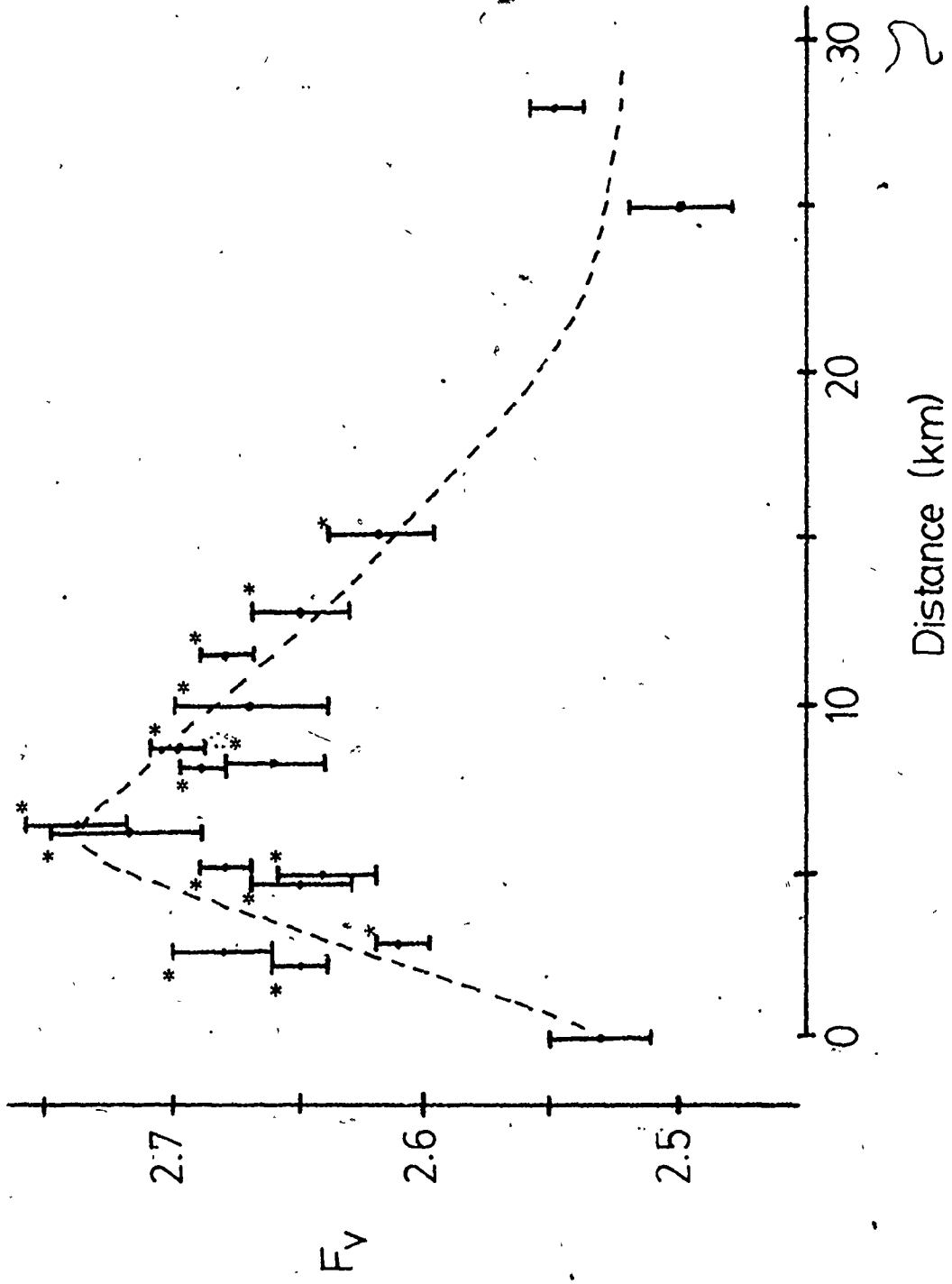

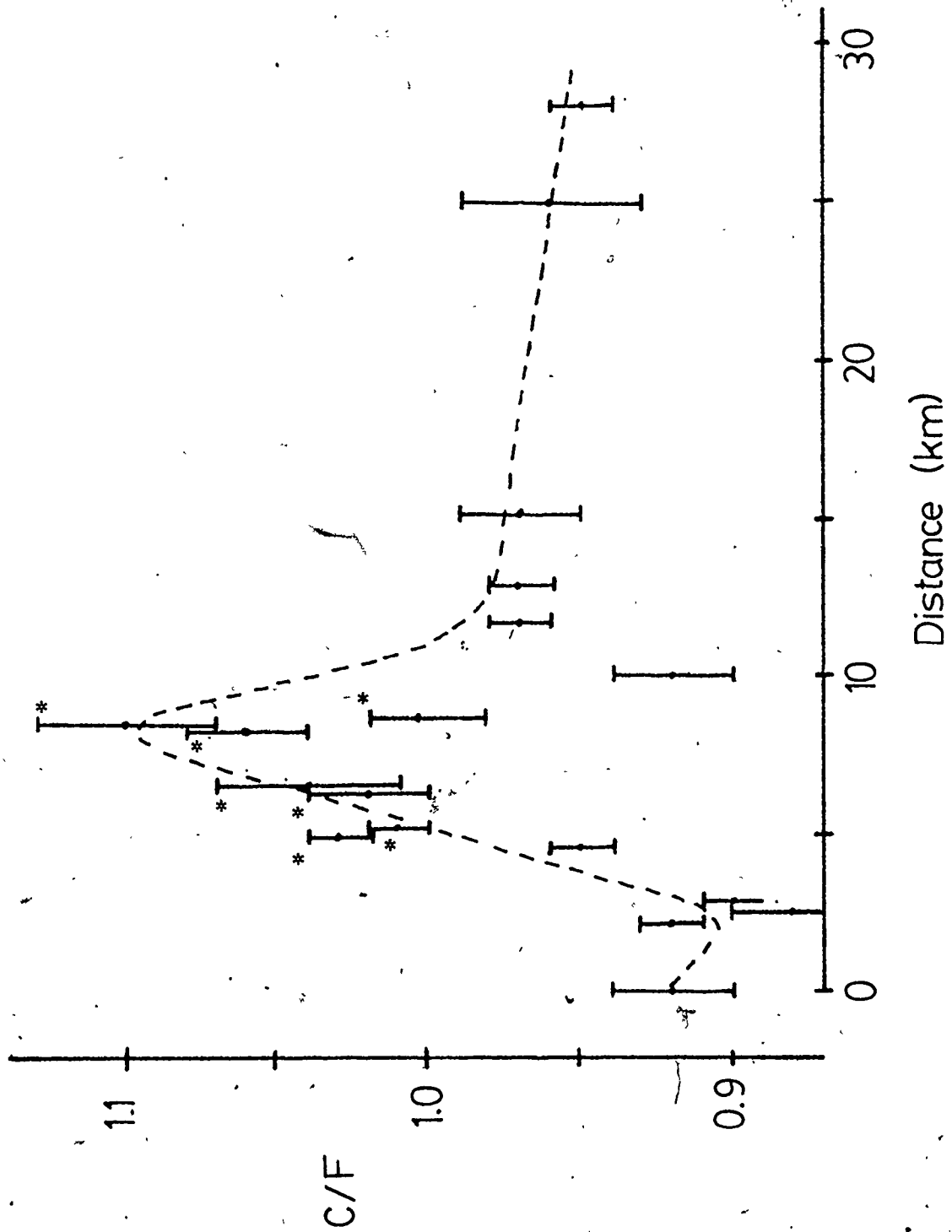

Figure 15: Mean C/F ratio in the transition zone as a function of total distance run, for rats exercised 6 days/week x 4 weeks following coronary artery occlusion.

\*  $p < 0.050$  with respect to the MI value of  $0.92 \pm 0.02$

Error bars denote standard errors of the mean.





in the transition zone. Thus, it appears that exercise can promote revascularization in the transition zone of the infarcted rat heart, but only under specific conditions.

### 5.3.3 Discussion

The first obvious question arising from my experiments is my choice of a voluntary exercise protocol, rather than forced swimming or running. Enforced swimming provides more than just physical exercise; it subjects the animals to a severe emotional stress (Leon et al., 1968; Bloor et al., 1970). Changes observed at the end of a swimming program may have either been masked or amplified by emotional stress, and I wished to avoid this added complication. Furthermore, Carrow et al. (1967) observed that rats allowed to run voluntarily demonstrated a greater per cent increase in C/F ratio in the gastrocnemius than those animals that were forced to run. This suggests that voluntary exercise is as effective a stimulus for capillary growth as forced running.

As mentioned previously, several authors have shown that exercise can increase the capillary supply in both heart and skeletal muscle of rats (Adolfsson et al., 1981; Carrow et al., 1967; Bloor et al., 1970; Leon et al., 1968; Tomanek, 1970; Bell et al., 1974). My results indicate that exercise can also be associated with revascularization in the transition zone of chronically infarcted rat hearts. In fact, for animals running a total distance of between five and ten km during the four weeks, mean values of  $V_f$ ,  $F_v$  and C/F returned to values which did not differ significantly from those of the controls. This implies that the capillary supply in the transition zone of these animals has returned to a normal configuration.

When mean  $F_v$  is plotted as a function of total distance run (figure 14), the peak in the curve is broad. This implies that very little exercise is required to change the capillary-fiber geometry, and that this change persists with more intense exercise unless the total distance run exceeds approximately 13 km. Peaks in the curves for  $V_f$  and C/F ratio (i.e. those representing capillary growth) are much sharper. This suggests that revascularization occurs under more specific conditions associated with exercise, whereas the shift in capillary-fiber geometry is a more immediate and prolonged response.

These experiments do not give direct proof that new capillaries grew in the transition zone of rats that ran a total distance of between five and ten km. This is implied, however, by the fact that the mean values of  $V_f$  and C/F ratio for these rats are significantly greater than those measured for the nonexercised MI's. Similar conclusions have been drawn in other studies which document increases in capillary density, C/F ratio and/or  $V_f$  following exercise (Adolfsson et al., 1981; Bell et al., 1974; Bloor et al., 1970; Leon et al., 1968; Tomanek, 1970; Guski, 1980). Using electron microscope autoradiography of  $^3\text{H}$ -thymidine labelled cells, Mandache et al. (1974) observed a higher degree of mitotic activity in endothelial cells of myocardial capillary walls in rats that had been exercised. This provides a more direct line of evidence for proliferation of myocardial capillaries in response to exercise.

Since mean values of  $V_f$ ,  $F_v$  and C/F ratio in the transition zone of rats that ran between five and ten km did not differ significantly from control values, this suggests that tissue  $pO_2$  gradients in the transition zone would also have returned to normal. In an attempt to

verify this, capillary density measurements were made, as described previously, for three rats which showed maximum improvement in mean  $V_f$ ,  $F_v$  and C/F ratio in response to exercise (table 4). Using Thews' Model, mean diffusion distance was determined; the Krogh Equation was then applied to estimate the tissue  $pO_2$  gradient in the transition zone of these three rats. As can be seen in figure 16, the tissue  $pO_2$  gradient for these exercised MI's is very similar to that obtained for normally perfused myocardium (refer to figure 11).

While this confirms the idea of a return to normal tissue oxygenation in the transition zone, two additional factors must be considered:

(1) although the muscle fibers in the transition zone are viable, the reduced microvascular supply and daily exercise may have resulted in values of M (resting myocardial oxygen consumption), and perhaps even K (oxygen conductivity), which differ from those of healthy myocardium. This was not taken into account in the calculations.

(2) increased capillary supply measured in a dead heart does not ensure that the capillaries are functional (Leon et al., 1968). Intuitively, however, it seems that if a region of tissue suffers from a sub-normal microvascular supply, the growth of new vessels should be of some benefit.

The fact that I observed a 'normal' capillary supply in the border zone of rats running from five to ten km in the month implies that the transition zone, defined as a region of viable muscle fibers with a sub-normal microvascular supply, no longer exists in the hearts of these animals. It is possible, however, that a border zone may still be present, if its presence is defined by other variables

Table 4

Capillary density and R (tissue cylinder radius) in the transition zone of three exercised MI's that demonstrated significant increases in capillary supply in the border region.

Rat	Distance (km)	Capillary density (#/mm <sup>2</sup> )	R (cm)
#2-1	8.30	2,321 ± 185	12.88 × 10 <sup>-4</sup>
#2-9	8.18	2,280 ± 102	13.00 × 10 <sup>-4</sup>
#5-2	8.68	2,305 ± 151	12.92 × 10 <sup>-4</sup>

Uncertainties for capillary density measurements are given as standard deviations about the mean.

Note that the mean values of capillary density do not differ significantly from the control value of 2,196 ± 223 per mm<sup>2</sup>.



Figure 16: Tissue  $pO_2$  in the transition zone of Rat #2-9 (total distance run = 8.18 km), calculated using the Krogh Model, as a function of radial distance from the center of the nearest capillary. Capillary  $pO_2$  is assumed to be 25 mm Hg, corresponding to the venous end of the network.

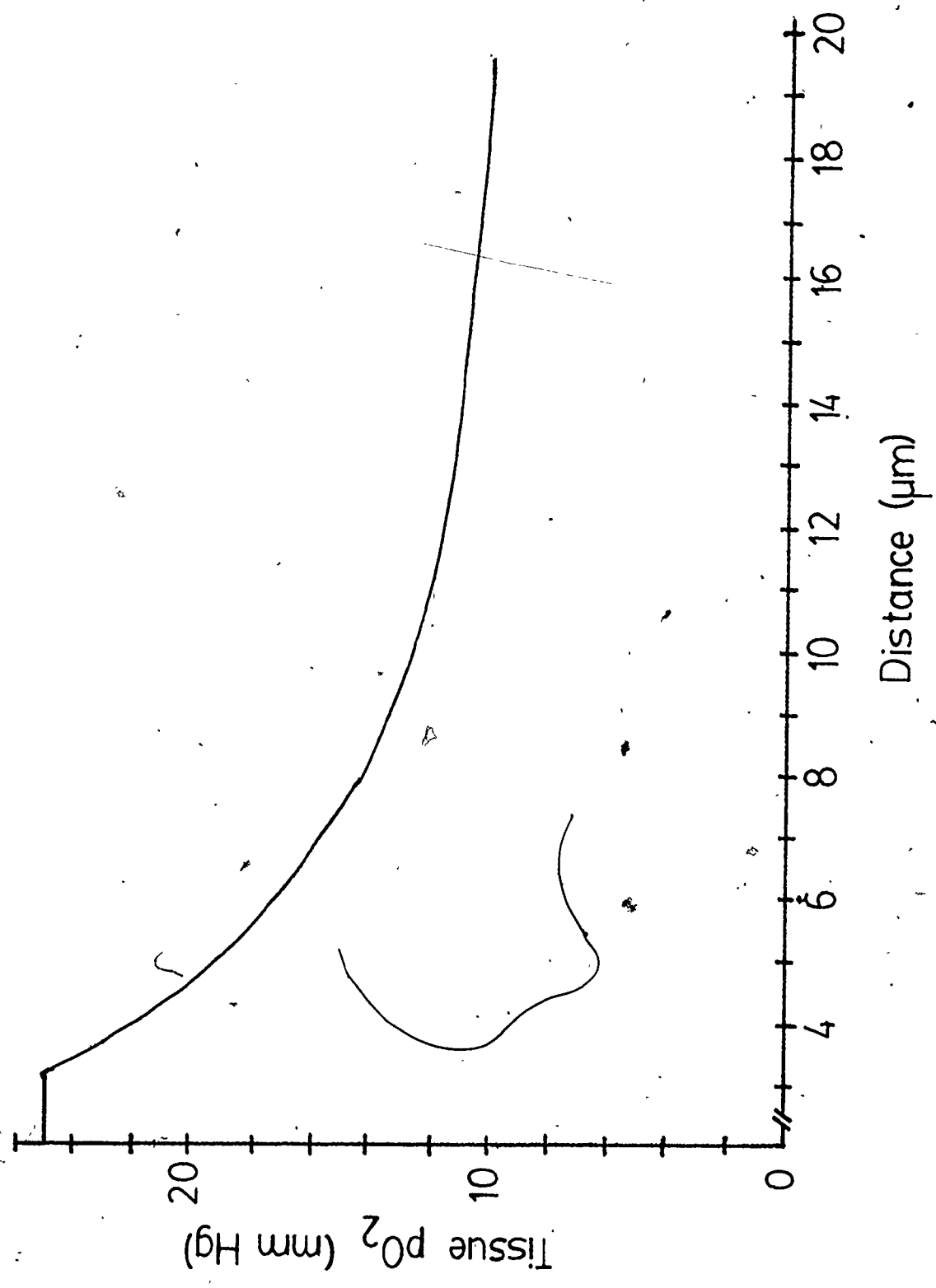

(i.e. biochemical, ultrastructural measurements were not made in this study).

In contrast, rats that ran less than five km or more than ten km during the four weeks of exercise showed no significant improvement in mean  $V_f$ ,  $F_v$  and C/F ratio in the transition zone. These results were unexpected - I had anticipated that if improvements in capillary supply could occur in response to 'moderate' exercise, they should persist at the greater total distances run, where the demand for oxygen and nutrients is also greater.

Similar results have been observed in other types of exercise experiments. As mentioned previously, Stevenson et al. (1964), who used the weight of acrylic casts of the coronary tree as an index of vascularization, observed that rats in 'moderate' exercise programs demonstrated a larger increase in the ratio of cast weight/heart weight than did those animals in more vigorous exercise regimes. It should be noted, however, that the acrylic casting medium did not penetrate vessels smaller than 40 to 50 um in diameter; thus, their measurements did not include the capillary network (Tepperman and Pearlman, 1961). Guski (1980) observed an increase in myocardial capillary density in rats after 45 hours of swimming, but no increase in capillary density was detected after rats swam for 180 hours. In contrast, Leon et al. (1968) found that measured increases in capillary supply were directly proportional to the amount of time the rats were forced to swim; it is possible, however, that the exercise was never of sufficient intensity or frequency to preclude the growth of new vessels. While the studies of Guski (1980) and Stevenson et al. (1964) are by no means analogous to mine, they do indicate that similar trends

have previously been documented in the literature.

The lack of improvement in capillary supply in the transition zone of MI's running the greatest total distances may be explained by a training effect. That is, if these animals experienced a training effect during the course of the experiment, then the same amount of daily exercise would act as a progressively smaller stimulus for cardiovascular changes. Thus, the animals may have adapted so well to the voluntary exercise that it no longer served to promote capillary growth in the transition zone. This explanation is based on the assumption that animals running the greatest total distances exercised at an intensity sufficient to produce peripheral or cardiovascular training. This was not proven, however, in my experiments.

Another obvious question arising from my experiments is: what effect would this voluntary exercise regime have on the microvasculature of the healthy rat heart? With this in mind, three normal, young male Wistar rats ( $222 \pm 5$  gm SD) were placed individually in Wahmann activity cages two hours per day, six days a week for four weeks, and allowed to run voluntarily. At the end of the month, the hearts were processed in the usual manner, and the sections stained for ATPase activity. Mean values of  $V_f$ ,  $F_v$ , and C/F ratio were determined for each rat (table 5). None of these three animals demonstrated significant increases in capillary supply above the usual control values.

These results seem to contradict the theory that exercise produces improvements in myocardial capillary supply. It is not possible, however, to directly compare my results with those of other authors, because of differences in the intensity of the various exercise programs used. To facilitate such a comparison, I have made use of another mathematical approximation.

Table 5

$V_f$  (vessels around a fiber),  $F_v$  (fibers sharing a vessel) and C/F ratio in healthy rat hearts, as a function of distance run.

Distance (km)	Intensity (% $\dot{V}O_2$ max)	$V_f$	$F_v$	C/F ratio
4.66	57%	$2.96 \pm 0.07$	$2.71 \pm 0.02$	$1.09 \pm 0.06$
8.58	59%	$3.02 \pm 0.06$	$2.71 \pm 0.03$	$1.08 \pm 0.03$
21.66	63%	$3.07 \pm 0.05$	$2.70 \pm 0.02$	$1.13 \pm 0.02$

Uncertainties for  $V_f$ ,  $F_v$  and C/F ratio are given as standard errors of the mean.

Note that these values of  $V_f$ ,  $F_v$  and C/F ratio do not differ significantly from the control values of  $3.03 \pm 0.02$ ,  $2.72 \pm 0.01$  and  $1.11 \pm 0.01$  respectively.

Oxygen uptake ( $\dot{V}O_2$ ) is thought to be the best indicator of metabolic rate, and thus the best index of exercise intensity (Shepherd and Gollnick, 1976). These authors measured the  $\dot{V}O_2$  of male rats as a function of running speed for animals exercised in an activity wheel of the same design as those used in my experiments. They found that  $\dot{V}O_2$  increased linearly as a function of running speed, to a maximum value ( $\dot{V}O_2$  max) of 9.51 ml  $O_2$ /100 gm body weight/ minute at a speed of approximately 50 meters/minute; beyond this point, the rate of oxygen uptake declined slightly. By using their linear relationship between oxygen uptake and mean running speed, a more valid comparison of exercise protocols is possible.

Tomanek (1970), who observed significant increases in myocardial capillary density and C/F ratio in healthy adolescent rats, exercised the animals on a treadmill at a running speed of approximately 1.25 miles/hour, or 33 meters/minute. This corresponds to an oxygen consumption of 8.19 ml  $O_2$ /100 gm/minute, or 86%  $\dot{V}O_2$  max. This was reinforced six days per week for 12 weeks. In my experiment, the rat that ran the greatest total distance in the four weeks (21.66 km, corresponding to a mean running speed of 7.52 meters/minute), was exercising at an average of 63%  $\dot{V}O_2$  max (table 5). These calculations suggest that the voluntary running done by the healthy rats in my study was not of sufficient intensity to stimulate capillary growth in normal hearts.

It may seem confusing that an apparently large change in mean running speed from 1.62 meters/minute (corresponding to a total distance run of 4.66 km) to 7.52 meters/minute (21.66 km) only results in a six per cent increase in  $\dot{V}O_2$  max (table 5). Because the rat has a high resting metabolic rate (approximately 30%  $\dot{V}O_2$  max), and  $\dot{V}O_2$  max

is attained at a mean running speed of 50 meters/minute, an increase of only 5.9 meters/minute does not constitute a major per cent increase in mean running speed or intensity.

The literature indicates that 'moderate' exercise can promote neovascularization in the myocardium (Stevenson et al., 1964; Guski, 1980). For healthy rats, 'moderate' running appears to signify an intensity of approximately 85%  $\dot{V}O_2$  max. My results show that exercise is also associated with significant improvements in capillary supply in the transition zone of MI's, but only in those animals exercising at an average intensity of 55% to 60%  $\dot{V}O_2$  max. Thus, revascularization in the transition zone occurs at a substantially lower exercise intensity than is required to stimulate neovascularization in healthy myocardium. This indicates that the definition of 'moderate' exercise is different for MI's than for healthy rats.

#### 5.4 Summary

When rats were exercised two hours per day, six days a week for four weeks following coronary artery occlusion, I obtained the following results:

(1) MI's running a total of between five and ten km during the month restored both a normal number of capillaries ( $V_f$ ) and a normal capillary-fiber geometry ( $F_v$ ) in the transition zone. This implies that the tissue  $pO_2$  gradient in the border zone has also returned to normal.

(2) animals running less than five km or more than ten km during the four weeks of exercise showed no significant improvement in capillary supply to the transition zone.

Thus, exercise can promote revascularization in the transition zone of infarcted rat hearts, but it only serves as an effective stimulus for capillary growth within a narrow range of intensities. How does the intensity, frequency and duration of the exercise protocol influence the growth of new capillaries in the transition zone? This question is addressed in the following chapter.



CHAPTER SIX: Importance of Exercise Frequency, Intensity and Duration  
on Revascularization in the Transition Zone

In previous chapters, I have provided evidence for the presence of a transition zone, characterized by viable muscle fibers with a sub-normal microvascular supply, five weeks following occlusion of the left coronary artery in the rat. In addition, I have shown that when rats are subjected to four weeks of daily voluntary running after coronary artery occlusion, the microvascular supply in the transition zone can be restored to normal. This only appears to occur, however, under certain conditions.

To further elucidate the relationship between exercise and capillary growth in the transition zone, three additional exercise protocols have been tested. These were designed to assess the relative importance of exercise frequency, intensity and duration on revascularization in the border zone.

#### 6.1 Protocol.

Using the standard procedure described in Chapter Two, left coronary artery ligation was performed on an additional 29 healthy male Wistar rats ( $201 \pm 24$  gm SD). As was the case in the previous exercise study, the animals were allowed one week to recover before the experiment was continued.

A total of four exercise protocols, varying in the frequency of exercise and the duration of the program, were tested; these are summarized in table 6. To facilitate a comparison of all the exercise protocols, the regime described in detail in the preceding chapter will be referred to in this chapter as "group A".

As described previously, the rats were placed individually in

Table 6  
Summary of voluntary exercise protocols

Group	Protocol			n
A	2 hr/day	6 days/week	4 weeks	17
B	2 hr/day	3 days/week (Mon., Wed., Fri.)	4 weeks	9
C	2 hr/day	6 days/week followed by 2 sedentary weeks	2 weeks	12
D	2 hr/day	6 days/week	2 weeks	8

Wahmann activity cages for the specified daily time period, and left to run on a voluntary basis. Daily revolutions were recorded and totalled, and converted to linear distances run.

At the end of the exercise programs, the animals were killed and the hearts processed, sectioned and stained in the usual manner. Mean values of  $V_f$ ,  $F_v$  and C/F ratio were obtained for each animal from photomicrographs of the transition zone, taken from sections stained for ATPase activity.

## 6.2 Results

In my initial series of experiments, I established that five weeks following coronary artery occlusion in the rat, mean values of  $V_f$ ,  $F_v$  and C/F ratio in the transition zone are 22%, 8% and 18% lower than those in the normal rat heart. When rats in exercise group A (six days/week x four weeks) ran a total distance of between five and ten km, these three variables returned to values which did not differ significantly from those found in healthy hearts. In contrast, rats that ran less than five km or more than ten km showed no significant increase in the three variables (figure 17). Thus, animals running an intermediate or 'moderate' total distance restored a normal capillary supply to the transition zone, whereas no improvement was seen at either extreme.

Rats in group B, running three days per week for four weeks, showed the same trends in mean  $V_f$  as a function of distance run as those animals in group A (figure 18). That is, maximum significant improvements in mean  $V_f$  were observed in those rats that ran the 'intermediate' total distances (approximately eight km), while no

evidence of significant revascularization was observed at distances less than or greater than the intermediate value.

None of the animals in group C, however, showed significant improvements in mean  $V_f$  within the transition zone (figure 19). Recall that these animals had been exercised six days per week for two weeks, and then were not exercised for the final two weeks of the study. If the myocardial capillary network is in fact a labile structure, it is possible that any improvements associated with the two weeks of exercise may have regressed during the two sedentary weeks.

To test this idea, the fourth exercise protocol was introduced. Rats in this group (D) were exercised six days per week for two weeks, and then killed immediately. Figure 20 shows that some of the rats in this group that ran approximately eight km during the two weeks did demonstrate a significant increase in mean  $V_f$  in the transition zone.

When changes in capillary-fiber geometry in response to exercise are considered, rats in all four exercise protocols running moderate or intermediate total distances (i.e. five to twelve km) showed significant increases in mean  $F_v$  within the transition zone (figures 17 to 20). That is, the capillary-fiber geometry in the border zone of these animals returned to a normal configuration. Although the peaks in the plots of mean  $F_v$  as a function of distance run are broader than those plotted for  $V_f$ , I observed no significant increase in either variable at the extreme distances run.

Changes in C/F ratio within the transition zone as a function of distance run (figures 17 to 20) paralleled the trends for  $V_f$  outlined above. Maximum significant improvements in mean C/F occurred in rats in groups A, B and D that ran intermediate total distances

Figure 17: Mean  $V_f$ ,  $F_v$  and C/F ratio in the transition zone  
as a function of total distance run for rats in  
Exercise group A: 6 days/week x 4 weeks.

\*  $p < 0.050$  with respect to the corresponding  
MI values

Error bars denote standard errors of the mean.

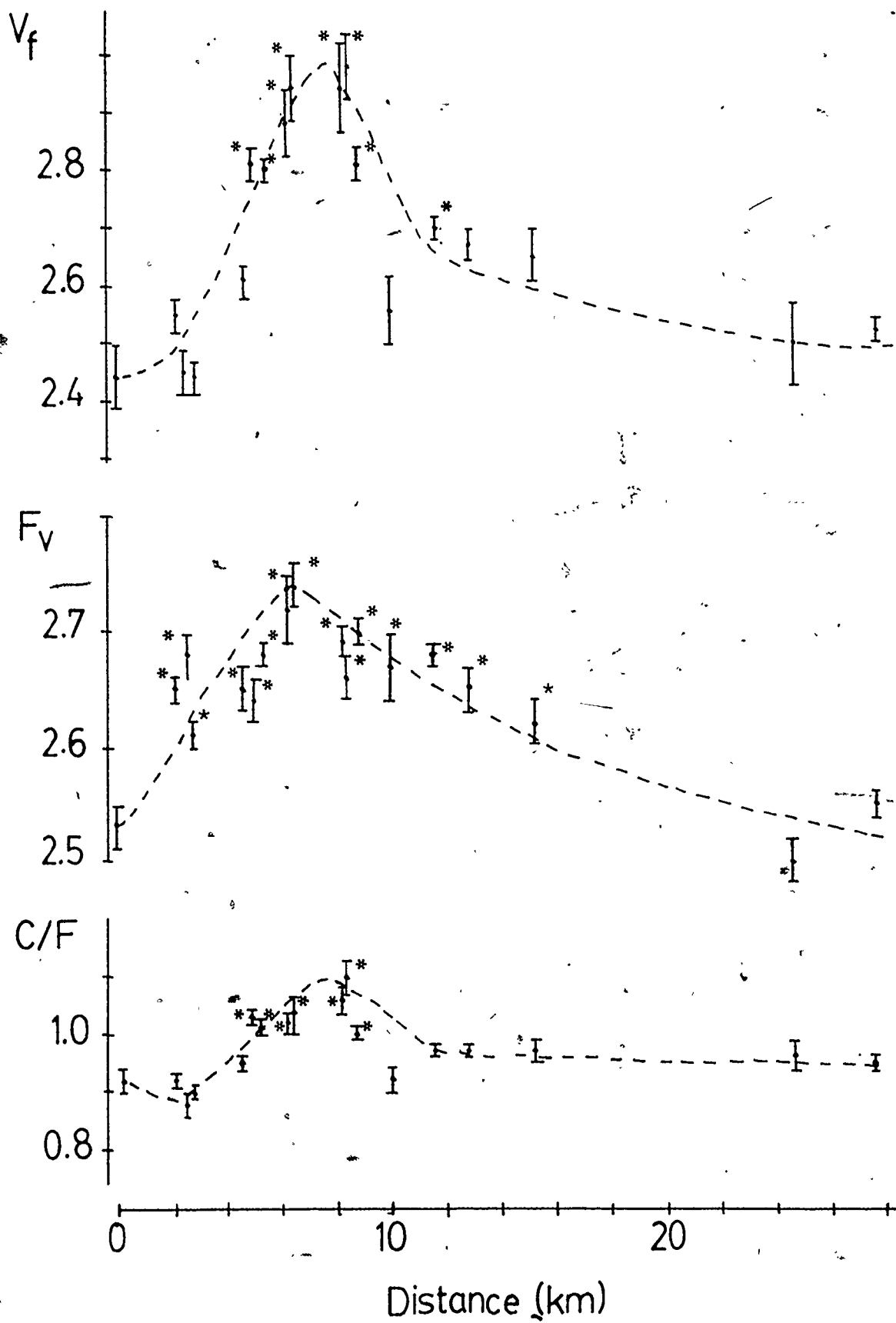



Figure 18: Mean  $V_f$ ,  $F_v$  and C/F ratio in the transition zone as a function of total distance run for rats in exercise group B: 3 days/week x 4 weeks.

\*  $p < 0.050$  with respect to the corresponding MI values.

Error bars denote standard errors of the mean.



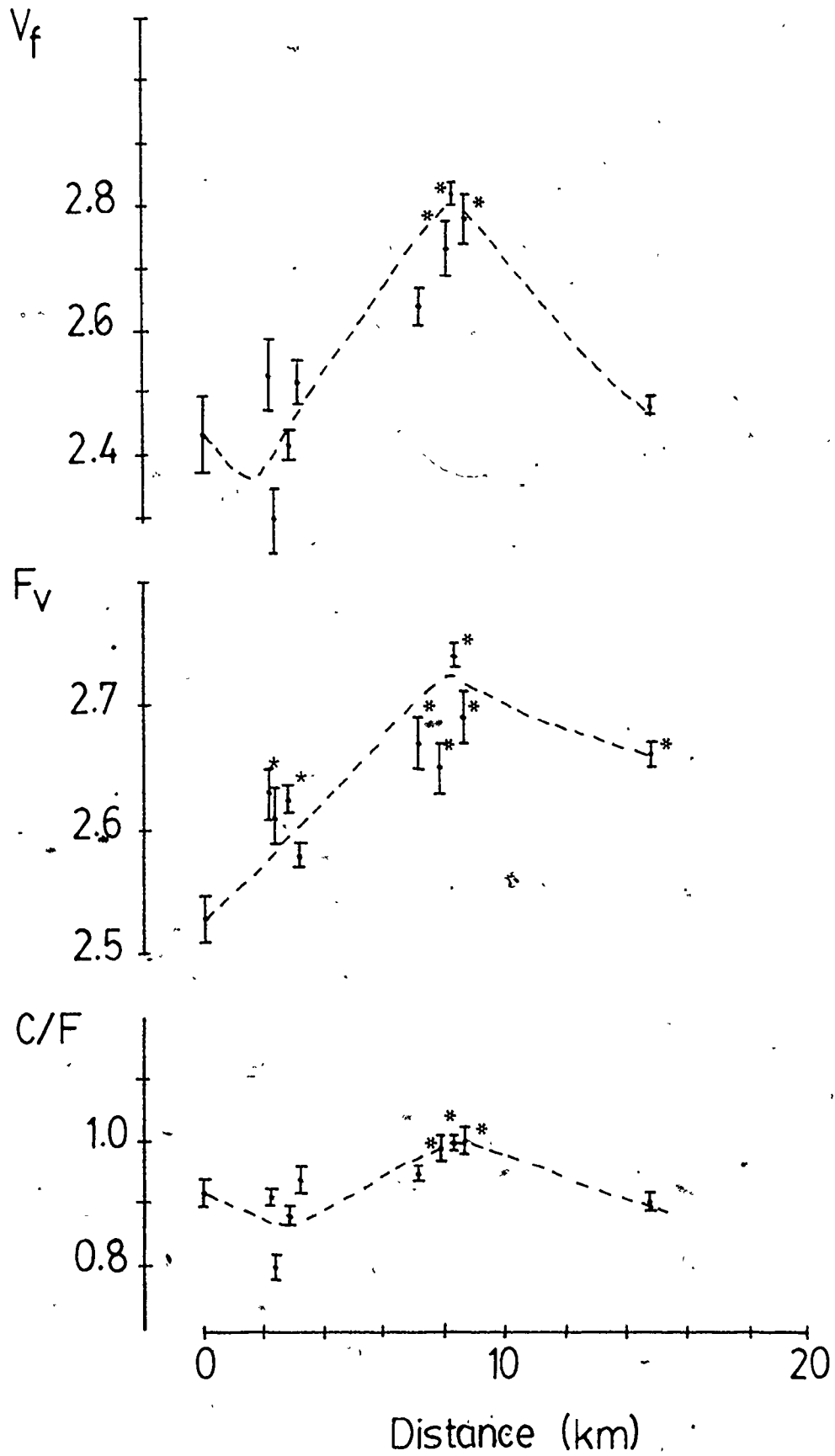

Figure 19: Mean  $V_f$ ,  $F_v$  and C/F ratio in the transition zone as a function of total distance run for rats in exercise group C: 6 days/week x 2 weeks, followed by 2 sedentary weeks.

\*  $p < 0.050$  with respect to the corresponding MI values.

Error bars denote standard errors of the mean.

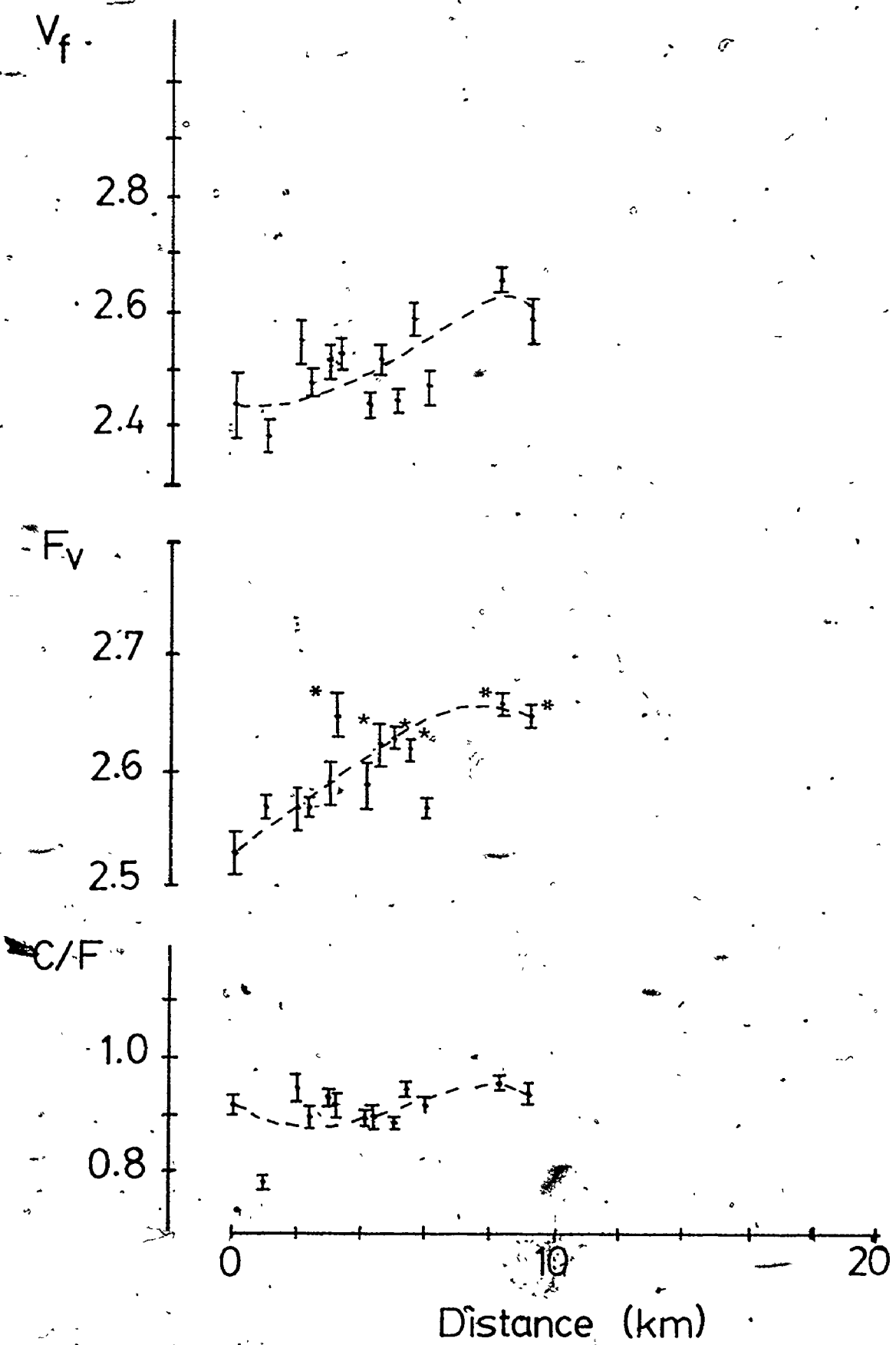
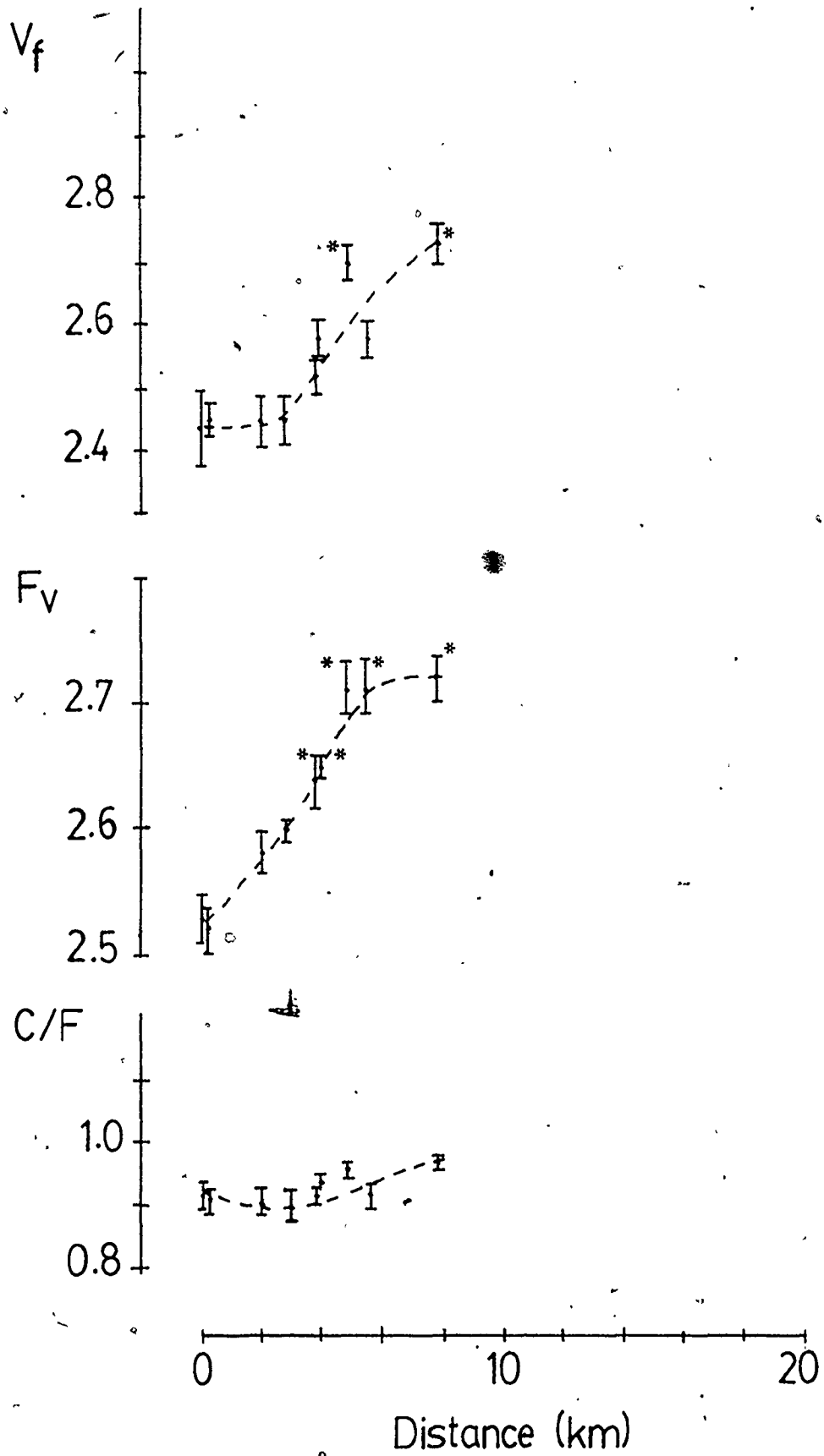

Figure 20: Mean  $V_f$ ,  $F_v$  and C/F ratio in the transition zone as a function of total distance run for rats in exercise group D: 6 days/week x 2 weeks.

\*  $p < 0.050$  with respect to the corresponding MI values.

Error bars denote standard errors of the mean.



(approximately eight km). No improvements in C/F ratio were observed in rats in these three groups that ran distances less than five km or more than 10 km, or in any of the animals in group C.

### 6.3 Discussion

The question of my choice of a voluntary exercise format, as opposed to forced exercise, has been discussed in the preceding chapter. The reasons behind my choice of the three additional exercise regimes should also be addressed.

Several of the experiments dealing with capillary growth in the myocardium have made comparisons between daily and intermittent (two to three times per week) exercise protocols (Stevenson et al, 1964; Leon et al., 1968; Bloor et al., 1970). Although the reasons for this have not been clearly stated by the authors, I believe it is based on the idea that exercise must be reinforced at least two to three times weekly if a cardiovascular training effect (i.e. decrease in resting heart rate, increased stroke volume, etc.) is to be achieved. My studies would determine whether capillary growth can also occur in animals that are exercised only two to three times per week, or whether daily exercise is required for neovascularization. To answer this question for the transition zone of infarcted rat hearts, and to facilitate a comparison of my results to those of other authors, I established exercise group B (three days per week x four weeks).

Another concept in exercise physiology is "detraining" - that is, how long do the beneficial effects of exercise remain, once the animal stops exercising? In my experiments, I wanted to know whether the significant improvements in capillary supply in the transition

zone persisted after the rats were no longer given access to the activity cages. The results from this group (C) were difficult to interpret. Although no significant increases in mean  $V_f$  or C/F ratio were observed, this may not be due to a detraining effect; rather, it is possible that no improvement in capillary supply had occurred during the two weeks of exercise. To resolve this question, exercise group D (six days per week x two weeks) was introduced.

It is interesting to note that maximum improvements in mean  $V_f$ ,  $F_v$  and C/F ratio in the transition zone occurred at a total distance run of approximately eight km for animals in both exercise groups A and B. Rats in group A ran six days per week for four weeks, while those in group B were only exercised three days per week (Monday, Wednesday and Friday) for the month, yet maximum revascularization in both cases was observed in animals that ran a total distance of roughly eight km. This implies that an important criterion for capillary growth in the transition zone is a balance between exercise frequency (how often the periods of exercise are reinforced) and mean running speed (average distance run per two hour exercise period). That is, if the exercise frequency is halved, the mean running speed must be doubled to produce the same degree of revascularization in the border zone.

In terms of oxygen consumption, animals in group A demonstrating maximum improvements in capillary supply exercised at an average intensity of 55% to 60%  $\dot{V}O_2$  max (calculated using the relationship between running speed and oxygen consumption developed by Shepherd and Gollnick, 1976). For rats in group B, running three times per week for four weeks, animals which showed significant increases in  $V_f$

and C/F ratio were exercising at approximately 61%  $\dot{V}O_2$  max. Although the mean running speed of these animals in group B was twice that of those in group A, the difference in running speed is not great enough to produce a substantial change in mean oxygen uptake, and therefore exercise intensity. Thus, in both groups A and B, rats running at approximately 60%  $\dot{V}O_2$  max demonstrated significant improvements in capillary supply in the transition zone.

Evidence from the literature supports the concept that a program of intermittent exercise can be as effective, or more effective, than daily exercise in improving the vascular supply of healthy rat myocardium. Recall that Stevenson et al. (1964) observed increases in the coronary vasculature of animals that ran on a treadmill twice per week for four weeks, while no improvement was seen in rats running at the same speed five days per week for four weeks. In the same study, rats that swam twice per week showed as great an increase in coronary tree size as those that swam five times weekly. Bloor et al. (1970) observed significant increases in C/F ratio in animals that swam daily and in those that swam intermittently. It should be noted, however, that in my study animals in group B had to run at twice the mean speed as rats in group A to obtain the same improvements in capillary supply. The question of the relationship between exercise frequency and intensity with respect to myocardial capillary growth was not pursued by Stevenson et al. (1964) or Bloor et al. (1970).

Note that no animal in group C demonstrated significant improvements in  $V_f$  or C/F ratio (i.e. no evidence of capillary growth) in the transition zone. Rats in group C (six days per week x two weeks, followed by two sedentary weeks) spent the same total amount



of time in the activity cages as did those animals in group B (three days per week x four weeks), yet instances of significant capillary growth were only observed in group B. This suggests that the exercise periods must be reinforced regularly during the course of the experiment if revascularization is to occur.

The fact that none of the animals in group C showed a significant increase in the number of capillaries in the transition zone can mean one of two things:

(1) no increase in mean  $V_f$  and C/F ratio had occurred during the two weeks of exercise. This implies that a minimum of two weeks of exercise is required for capillary growth to occur.

(2) improvements in capillary supply during the two weeks of exercise regressed during the two sedentary weeks.

The fourth exercise protocol (group D) was included to answer this question. Several animals in this group did demonstrate values of  $V_f$  and C/F ratio in the transition zone which were significantly greater than those found in the unexercised MI's. In fact, the shapes of the plots of  $V_f$  as a function of distance run for exercise group D (six days per week x two weeks) and B (three days per week x four weeks) are very similar. Since no improvements in capillary supply were seen in group C, this suggests that some regression had occurred during the two weeks of inactivity.

This result differs from that of Leon et al. (1968). Significant increases in C/F ratio were observed in the healthy hearts of rats forced to swim one hour per day for ten weeks. No regression in C/F ratio was found, however, as long as 14 to 42 days following cessation of the exercise program. This discrepancy may be due to

the very different protocols used: Leon et al. (1968) allowed their healthy animals to swim for ten weeks, while my rats in group C were subjected to two weeks of voluntary running following occlusion of the left coronary artery.

To this point in the discussion, I have assumed that no rats following exercise protocol C would show significant improvement in capillary supply within the transition zone. Note that none of the animals in group C (or group D) ran a total of more than ten km during the two weeks of exercise; it is possible that  $V_f$  or C/F ratio may have increased, had the rats run distances greater than this. For the sake of completeness, it would have been desirable to obtain more data for distances in excess of ten km. However, of the 47 exercised MI's in the four exercise protocols, only one animal ran farther than ten km in 12 days of exercise, and two exceeded 20 km in 24 days of running. Thus, while it might have been informative to obtain data in this region of the graphs, the probability of a rat running that distance is quite small.

Changes in capillary-fiber geometry (measured using the variable  $F_v$ ) in the transition zone in response to exercise differ slightly from the trends observed for  $V_f$  and C/F ratio. I have found that five weeks following ligation of the left coronary artery, the mean  $F_v$  value in the transition zone is significantly less than that found in normal rat myocardium. This indicates that the relative positions of capillaries and fibers in the heart are not fixed. Subsequently, I found that  $F_v$  in the transition zone could be restored to the normal control value in response to four weeks of daily voluntary exercise, implying that the capillary-fiber geometry in this

region is labile and apparently sensitive to the metabolic demands of the tissue. As was the case with  $V_f$  and C/F ratio, significant improvements in mean  $F_v$  occurred only in animals running intermediate total distances.

Figures 17 to 20 show the relationship between mean  $F_v$  and total distance run for the four exercise protocols that have been studied. Significant improvements in mean  $F_v$  were obtained for animals in all four exercise regimes, including group C (six days per week x two weeks, followed by two sedentary weeks). This suggests that the shift in capillary-fiber geometry associated with the two weeks of exercise did not regress during the two weeks of inactivity, as was the case with  $V_f$ . Improvements in mean  $F_v$  were also consistently observed only in animals that ran intermediate total distances (between five and ten km). However, two observations suggest that the metabolic conditions required for altering capillary-fiber geometry are not as specific as those needed for revascularization in the transition zone:

(1) peaks in the graphs of  $F_v$  as a function of distance run are consistently broader than those for  $V_f$  or C/F ratio.

(2) improvements in  $F_v$  are seen in the border zone, even when there is no evidence of capillary growth.

To my knowledge, the importance of exercise frequency, intensity and duration on capillary-fiber geometry in the myocardium have not been discussed previously in the literature.

#### 6.4 Summary

I have found that exercise can restore both the absolute number of capillaries ( $V_f$ ) and the capillary-fiber geometry ( $F_v$ ) in the transition zone of infarcted rat hearts to normal, control values. Important factors in this revascularization process appear to include:

(1) an intermediate total distance run.

(2) a balance between exercise frequency and mean running speed.

It is interesting, however, that maximal improvements in capillary supply consistently occurred in rats exercising at a mean intensity of approximately 60%  $\dot{V}O_2$  max.

(3) regular reinforcement of the exercise periods during the course of the experiment. This is especially important for the maintenance of improved  $V_f$  values.

Comparison of my results to those of other authors is difficult; one reason for this is the fact that other groups studying neovascularization in the myocardium have used forced exercise protocols. With this in mind, I have tested a forced exercise regime and shall compare this to the results of the voluntary exercise experiments. This is discussed in Chapter Seven.

CHAPTER SEVEN: Comparison of Forced vs. Voluntary Exercise  
on Revascularization in the Transition Zone

To this point in the thesis, I have dealt with the effects of voluntary exercise on capillary supply in the transition zone of infarcted rat myocardium. My results indicate that moderate voluntary exercise can promote revascularization in the transition zone, provided that the exercise periods are reinforced regularly, and there is a balance between exercise frequency and mean running speed.

Experiments by Carrow et al. (1967) compared the effects of forced and "spontaneous" (voluntary) exercise on capillary growth in rat skeletal muscle. Specifically, one group of rats was allowed daily periods of running in activity cages, while the forced exercise group was subjected to 30 minutes of swimming per day. After 35 days of exercise, the C/F ratio for red and white muscle fibers in the gastrocnemius was determined for each animal. Increases in the value of C/F ratio were observed for both muscle fiber types, in response to both exercise regimes. However, the largest per cent increases in C/F ratio were consistently found in animals subjected to voluntary exercise.

To my knowledge, no similar comparison of the effects of forced and voluntary exercise on capillary growth in the myocardium has been made. Predictably, no such study has previously been conducted on MI's. I have subjected a group of MI's to a regime of forced running, in a format comparable to that used for group A (six days per week x four weeks) of the voluntary exercise experiments (refer to chapters four and five), and then quantified the capillary supply to the transition zone of each animal. As most authors have used forced (rather than voluntary) exercise to stimulate myocardial capillary

growth, this will further enable me to compare my results to the work of others.

### 7.1 Protocol

Left coronary artery ligation was performed on eight healthy male Wistar rats ( $214 \pm 24$  gm SD), using the procedure detailed in the second chapter. The animals were allowed one week to recover before the experiment was continued.

For the forced exercise study, four of the standard Wahmann activity cages used in the voluntary exercise experiments were joined in series and driven simultaneously by a 1/15 horsepower Dayton gearmotor. The rpm of the motor (and thus the resultant rpm of the activity cages) could be varied, such that the speed of the activity wheels ranged from approximately 2.5 to 15 revolutions per minute. Once the speed of rotation was selected, it remained constant to within approximately two per cent (as measured with a stopwatch) for the duration of the exercise period. In addition, all four wheels rotated at the same speed, again to within two per cent of each other. (I would like to acknowledge the assistance of Livio Rigutto and Dr. Ian MacDonald in the assembly of this apparatus.)

The rats were forced to run in the motorized exercise wheels six days per week for a total of four weeks. This protocol is comparable to that of group A of the voluntary exercise regimes, which forms the basis of my myocardial revascularization studies.

Three subgroups, running at different speeds, were established:

(1) 4.48 meters/minute ( $n=3$ ), such that a total distance run of approximately 5,000 meters during the four weeks was obtained.

(2) 6.72 meters/minute ( $n=3$ ), to yield a total distance of approximately 9,500 meters.

(3) 8.96 meters/minute ( $n=2$ ), to result in a total distance of approximately 15,500 meters.

In establishing these subgroups, several criteria had to be met. First, as I wished to compare the results of the forced exercise study to those of group A, these animals had to run total distances that fell within the same range as those totalled by the rats that ran voluntarily. As maximum improvements in capillary supply were observed in rats that voluntarily ran eight to ten km, subgroup (2) was of particular interest (i.e. this would establish whether a peak response also occurred at the same total distance in the forced exercise protocol).

Second, it was important to select speeds at which the animals were able to run. At speeds less than 4.48 meters/minute, the animals were able to run faster than the wheels were turning, while at speeds greater than 8.96 meters/minute, the animals could not keep up with the wheels. An additional complication was caused by the fact that the rats could not run continuously at these speeds; this was especially true for animals in groups (2) and (3). Thus, the motor was run on an automatic timer, such that the wheels rotated for five minutes and then stopped for three minutes, giving the animals a short rest between the five-minute exercise periods. As a result of these three factors (total distance, running speed and rest periods), animals in subgroups (1) and (2) were in the activity cages for approximately 1.5 hours per day, while those in subgroup (3) were in the wheels for 1.75 hours per day.

Initially, four animals had been placed in the second exercise



subgroup (6.72 meters/minute). One of the animals, however, was not able to run at this speed, thus was exercised at 4.48 meters/minute for the remainder of the experiment. This accounts for the one data point on the graphs located at a total distance run of approximately seven km. In addition, one rat running at the slowest speed developed a respiratory infection one third of the way through the experiment. The animal was administered oral tetracycline, and was not exercised for three days. At this point, the rat appeared to have recovered and was put back into the exercise program, but as a result, the animal ran a total distance slightly less than 5,000 meters.

At the end of the experiment, the animals were killed and the hearts removed, sectioned and stained as described previously. Photomicrographs of the transition zone were taken from the sections stained for ATPase activity, and mean values of  $V_f$ ,  $F_v$  and C/F ratio determined for each animal.

## 7.2 Results

Figures 21, 22 and 23 illustrate the changes in mean  $V_f$ ,  $F_v$  and C/F ratio in the transition zone as a function of total distance run. The data points and error bars denote the results for the forced exercise experiment, while the dotted lines depict the trends observed for voluntary exercise group A (six days per week x four weeks). Results for both sets of experiments are presented together to facilitate their comparison.

No significant improvement in mean  $V_f$  was observed in the transition zone of any of the eight rats subjected to forced exercise (figure 21). This is in contrast to the voluntary exercise study,

Figure 21: Mean  $V_f$  in the transition zone as a function of total distance run

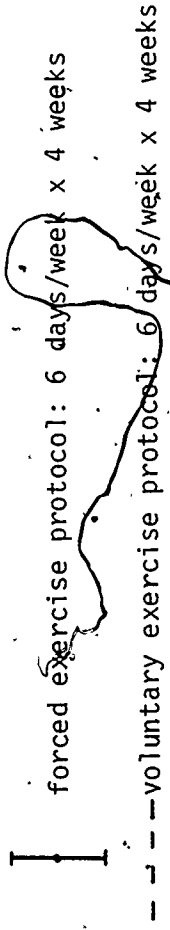

Error bars denote standard errors of the mean.

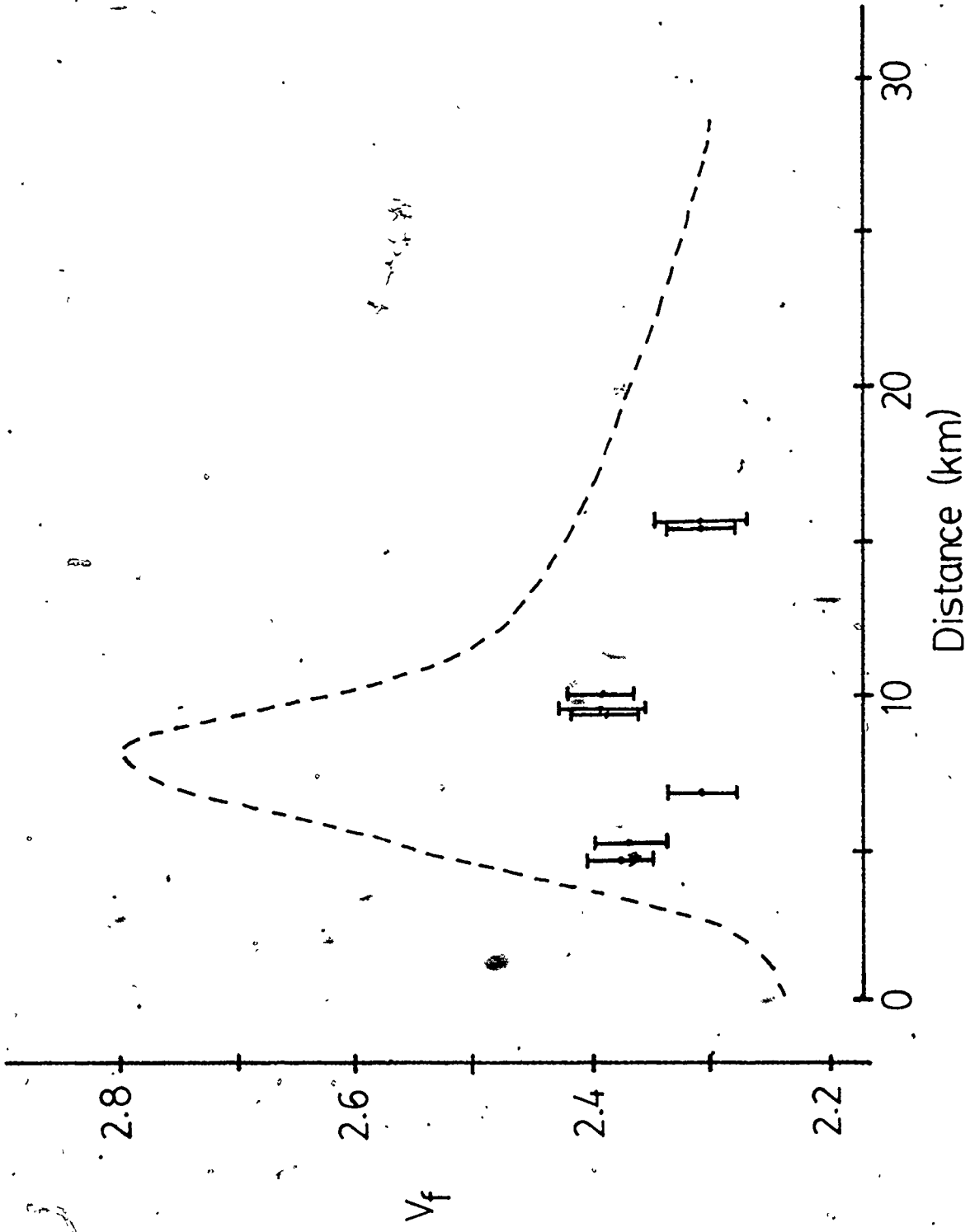
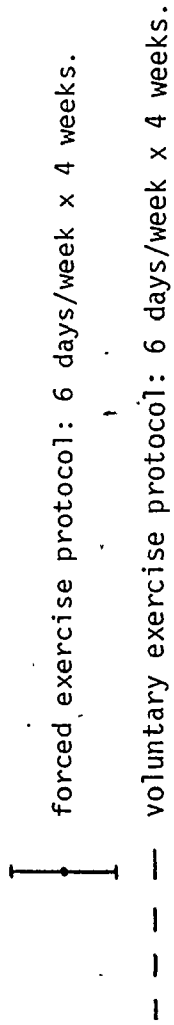

Figure 22: Mean  $F_v$  in the transition zone as a function of total distance run



\*  $p < 0.050$  with respect to the MI value of  $2.52 \pm 0.02$

Error bars denote standard errors of the mean.

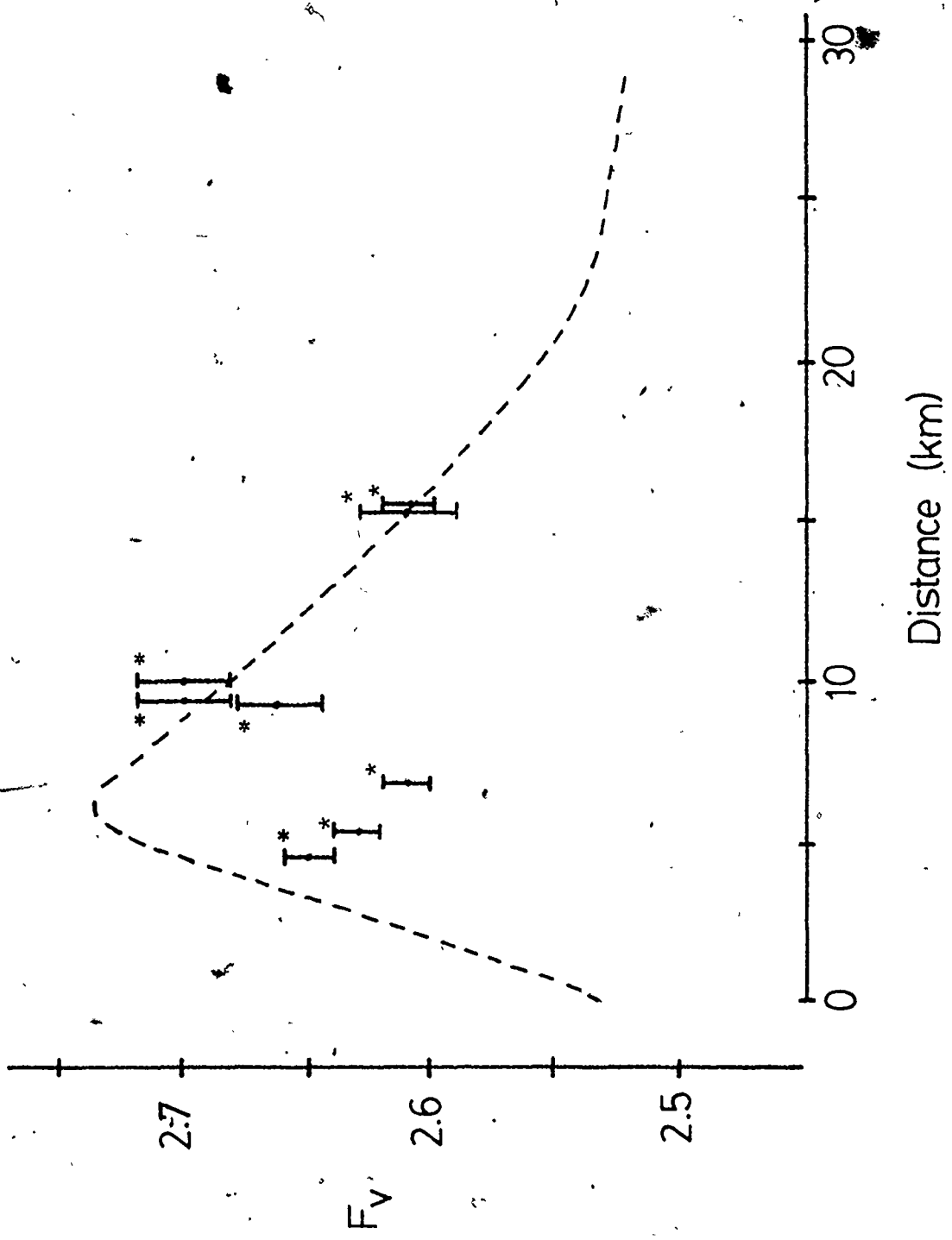
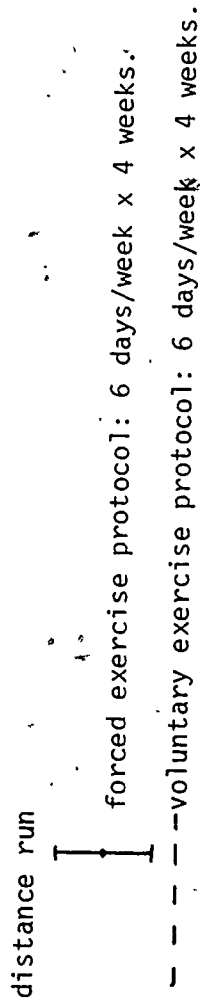
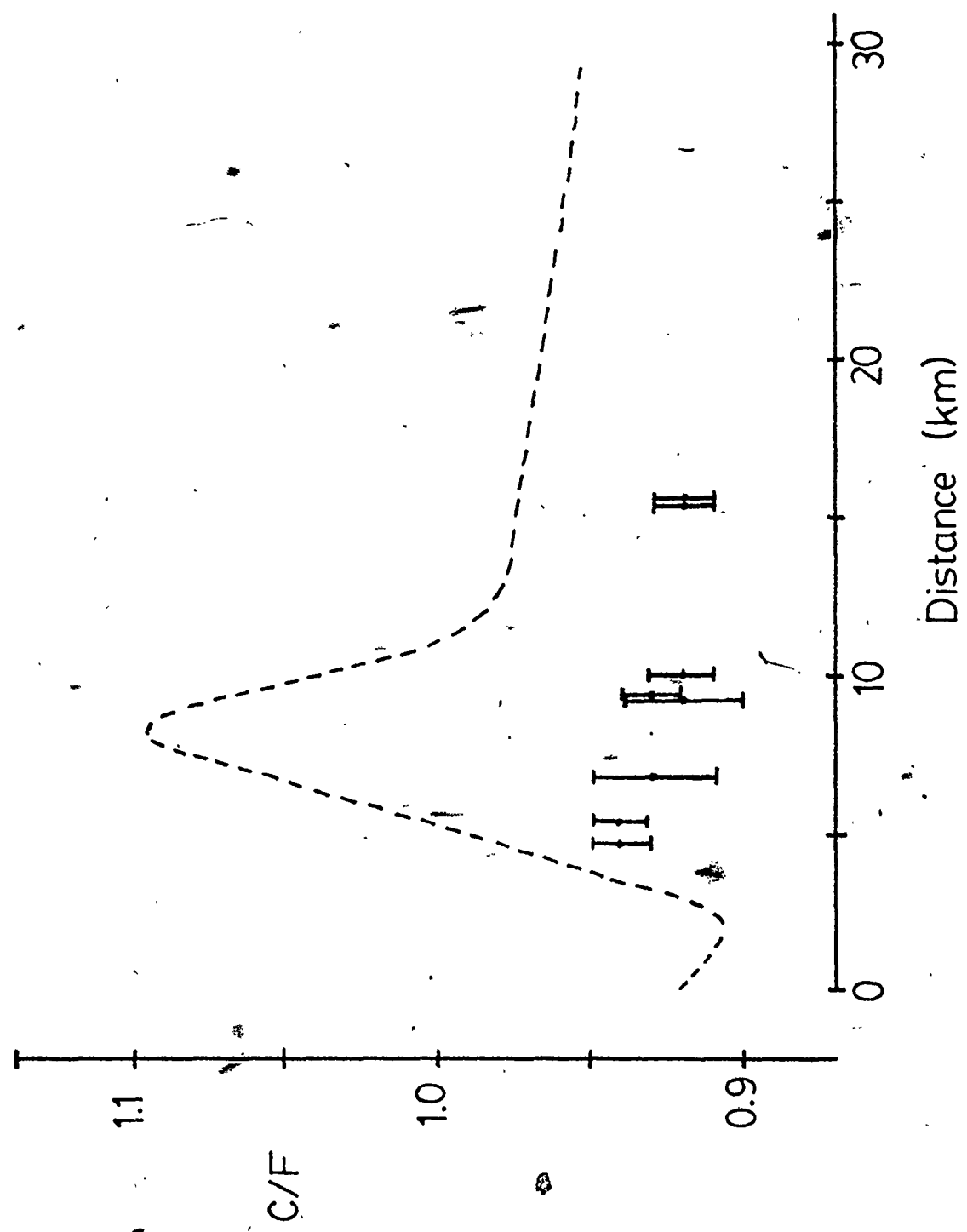

Figure 23: Mean C/F ratio in the transition zone as a function of total



Error bars denote standard errors of the mean.



in which animals running a total distance of between five and ten km in the four weeks demonstrated values of mean  $V_f$  which did not differ significantly from the  $V_f$  value found in healthy rat myocardium.

Some of the animals in the forced exercise program did, however, exhibit significant increases in mean  $F_v$ ; maximum improvements in capillary-fiber geometry occurred in those animals forced to run a total distance of approximately 9.5 km during the month (figure 22). In this instance, the results of the voluntary and forced exercise regimes are in good agreement.

As was the case in the previous voluntary exercise experiments, changes in C/F ratio as a function of total distance run for rats in the forced exercise group paralleled the trends observed for mean  $V_f$ . That is, no significant increase in mean C/F ratio was observed in any of the animals that were forced to run (figure 23). Again, these results differ considerably from those of the comparable voluntary exercise protocol.

### 7.3 Discussion

My results indicate that forced and voluntary exercise over the same range of intensities are not equally effective stimuli for revascularization in the transition zone. This is evident when values of  $V_f$  and C/F ratio as a function of distance run are compared for the two protocols. Significant increases in mean  $V_f$  and C/F ratio occurred in animals that chose to run a total distance of between five and ten km during the four weeks, whereas no improvement in  $V_f$  or C/F ratio was observed in any of the rats that were forced to run. This supports the results of Carrow et al. (1967), which indicate that voluntary



exercise provides a more effective means of increasing the C/F ratio in skeletal muscle than does forced exercise. The different results produced by the two methods appear to be even more striking in the transition zone of infarcted rat hearts.

As mentioned in the introduction to this chapter, a comparison of the effects of forced and voluntary running on capillary growth in the myocardium has not been previously reported in the literature. Stevenson et al. (1964), however, incorporated a 'voluntary' swimming protocol into his exercise experiments: a board was placed in the swimming basin, on which the animals could rest. They observed an increase in the ratio of coronary cast weight/heart weight in these animals, but it did not prove to be significant. In contrast, rats that swam without the option of resting demonstrated significant increases in relative coronary tree size. The authors state, however, that rats in the 'voluntary' swimming protocol spent ". . . the majority of their time resting". This was not the case in my voluntary running experiments; thus, the two studies are not analogous.

As was outlined at the beginning of Chapter Four, several researchers have shown that some forms of forced exercise can stimulate capillary growth in the heart. Tomanek (1970) found significant increases in myocardial capillary density and C/F ratio in rats following 12 weeks of daily running on a treadmill. Improvements in these two variables were also observed in rats subjected to daily periods of swimming (Leon et al., 1968; Bloor et al., 1970; McElroy et al., 1978; Guski, 1980; Bell and Rasmussen, 1974). In addition, Stevenson et al. (1964) documented increases in the ratio of coronary cast weight/heart weight in response to both running and

swimming.

Evidence from the literature indicates that forced exercise should be an effective means of initiating capillary growth in the heart. However, my data provides no such evidence for neovascularization in the transition zone of MI's (i.e. no significant increases in  $V_f$  or C/F ratio were observed).

In the experiments of Tomanek (1970), the rats that exhibited significant increases in myocardial capillary supply ran at a mean intensity of approximately 85%  $\dot{V}O_2$  max (calculated using the formula derived from the data of Shepherd and Gollnick, 1978). In contrast, my animals in the forced exercise protocol ran at mean intensities ranging from 60%  $\dot{V}O_2$  max (corresponding to a mean running speed of 4.48 meters/minute) to 64%  $\dot{V}O_2$  max (8.96 meters/minute). Recall the hypothesis introduced in Chapter Four, suggesting that "moderate exercise with adequate rest may benefit the heart more than heavy, frequent exercise" (Stevenson et al., 1964). It is possible that, by being forced to run six days per week at a mean intensity of 60% to 64%  $\dot{V}O_2$  max, the exercise is too 'heavy and frequent' to stimulate capillary growth in the transition zone of MI's.

It should be noted, however, that voluntary running six days per week for four weeks at the same range of intensities produced significant increases in both  $V_f$  and C/F ratio in the transition zone. A hypothesis to explain this apparent paradox between forced and voluntary exercise will be presented in the following chapter, the general discussion.

While there was no evidence of capillary growth in the transition zone in response to forced exercise, significant increases in mean  $F_v$

were obtained. Capillary-fiber geometry in the transition zone of rats forced to run approximately 9.5 km in the month did not differ significantly from that found in healthy rat hearts. In contrast to the findings for  $V_f$  and C/F ratio, changes in  $F_v$  as a function of distance run were similar for both the forced and voluntary exercise protocols. This reinforces the concept that the conditions required to alter capillary-fiber geometry in the transition zone are not as specific as those needed to stimulate capillary growth.

#### 7.4 Summary

When rats were forced to run six days per week for four weeks following coronary artery occlusion, the following results were obtained:

(1) no evidence of capillary growth was found in the transition zone of any of the animals in the forced exercise regime (i.e. no significant increases in  $V_f$  or C/F ratio were observed). This is in contrast to the results of the comparable voluntary exercise study, in which rats running a total distance of between five and ten km during the month restored a normal number of capillaries in the transition zone.

(2) changes in capillary-fiber geometry ( $F_v$ ) as a function of distance run for rats in the forced exercise protocol are in good agreement with the results of the corresponding voluntary exercise experiment.

Thus, forced and voluntary exercise are not equally effective in promoting capillary growth in the transition zone of infarcted rat hearts. The apparent paradox that arose from this comparison, and the

previously documented fact that only 'moderate' voluntary exercise is associated with significant improvements in capillary supply in the transition zone, are two unusual and unexpected results that emerged from my research. In my final chapter, the general discussion, I will present a theory to explain the means by which exercise stimulates capillary growth in the heart, and a hypothesis to explain my two 'unusual' observations.

CHAPTER EIGHT: General Discussion

### 8.1 Reduced Microvascular Supply in the Transition Zone

I have found that a transition zone, defined as a region of viable muscle fibers with a sub-normal microvascular supply, is present in the rat heart five weeks following surgical occlusion of the left coronary artery. This confirmation of the presence of a transition zone in the chronically infarcted heart forms the basis for the remainder of the thesis - had there been no transition zones, then experiments designed to 'salvage' this region would clearly have been pointless. In light of the controversy in the literature concerning the presence or absence of a salvageable border zone, I believe my finding is significant.

My results indicate that the transition zone is characterized by:

- (1) fewer capillaries surrounding each muscle fiber, reflected in a lower value of mean  $V_f$ .
- (2) fractionally fewer fibers sharing each remaining capillary, measured as a reduction in mean  $F_v$ .
- (3) lower values of capillary density and C/F ratio.
- (4) a tendency toward fiber hypertrophy and greater intercapillary distance.

How can each of these four observations be explained? To facilitate the discussion, each observation will be considered in turn.

#### 8.1.1 Reduction in mean $V_f$

In healthy hearts, each muscle fiber tends to be surrounded by three capillaries (mean  $V_f = 3.03 \pm 0.02$ ), while in the transition zone of the MI's, the 'typical' fiber is supplied by only two

capillaries (mean  $V_f = 2.34 \pm 0.06$ ).

It seems reasonable to assume that if a capillary is not filled with blood (thus the endothelial cells of the capillary wall do not have access to an oxygen supply) for a prolonged period of time, the endothelial cells would die and the capillary would no longer exist. If this is true, then my data implies that not less than 25% of the capillaries present in the region destined to become the transition zone were not perfused following coronary artery occlusion.

This then suggests that the three regions of the chronically infarcted rat heart can be classified according to their pattern of perfusion prior to ligation of the coronary artery. That is, the necrotic zone was originally serviced only by vessels arising immediately distal to the ligature; thus, blood flow to this region was essentially stopped once the artery was occluded. The remaining normal myocardium was supplied by vessels originating proximal to the ligature, ensuring that blood flow to this area was virtually uninterrupted. The transition zone, however, was supplied by vessels which originated both above and below the ligature; such an arrangement would be in agreement with the observations of Brown (1965), who found that any given area of myocardium was supplied by several arterioles, whose daughter capillaries intermesh.

It would be tempting to state that approximately 75% of the capillaries in the transition zone arose from arterioles and arteries originating proximal to the site of occlusion, while the remaining 25% originated distal to the ligature. It is not possible, however, to draw this conclusion based solely on my data: Microvascular supply was measured five weeks after the coronary artery was ligated; it is

possible that a smaller percentage of vessels originated proximal to the ligature, and some capillary proliferation had occurred during the five weeks between the surgery and the time of sampling. A study of capillary supply in the transition zone as a function of time following coronary artery occlusion would be required to solve this question.

Alternatively, if there is no appreciable interdigitation of terminal vascular beds in the rat heart (i.e. in accordance with the observations of Okun et al. (1979) and Factor et al. (1981) in canine hearts), one would expect to see a sharp boundary between normally perfused tissue and the necrosis. The chronic presence of a transition zone with a sub-normal microvascular supply could then be explained by the growth of capillaries from the edge of the normally perfused myocardium toward the developing necrosis. This growth would have to be extremely rapid to account for the viability of the fibers in the transition zone. Cotter et al. (1973) and Brown et al. (1976) observed significant increases in capillary density and C/F ratio in skeletal muscle within four days after the onset of chronic stimulation, but there is no evidence in the literature citing significant capillary growth within the first 24 hours of an experiment. This explanation for the presence or development of the transition zone appears to be inadequate.

In any case, it is interesting to note that the muscle fibers in the transition zone remain viable, even when the mean  $V_f$  has been reduced by approximately 25%. I believe this additional 25% found in healthy myocardium represents a 'margin of safety', which is not required under normal metabolic conditions, but may be essential under conditions of extreme stress or metabolic demand. This reserve



has been lost in the transition zone.

#### 8.1.2 Reduction in mean $F_v$

A decrease in the number of capillaries surrounding each muscle fiber does not predetermine an accompanying change in  $F_v$ , the number of fibers sharing each capillary. That is, if one capillary out of every four dies, it is possible that the remaining capillaries still tend to be situated between three muscle fibers, as in normal rat myocardium. In the transition zone, however, each capillary tends to supply two fibers. This lends credence to the concept that the microcirculation is labile and dynamic - the positions of capillaries with respect to muscle fibers are not fixed.

I believe the decrease in mean  $F_v$  in the transition zone represents an adaptation to protect the fibers from possible hypoxia. The total number of capillaries supplying each muscle fiber (mean  $V_f$ ) has been reduced significantly. If each capillary now tends to be shared by two fibers rather than three, each fiber can receive one half rather than one third of the available oxygen from that capillary. In other words, each fiber can obtain a fractionally larger amount of the total oxygen content from the fewer remaining capillaries. In addition, this observed shift in capillary-fiber geometry will result in a more uniform distribution of intercapillary distances within the transition zone, thereby reducing the incidence of anoxic or hypoxic pockets of tissue, which could be produced when every fourth capillary is removed. Although it would be difficult to demonstrate in vivo, it seems a reduction in mean  $F_v$  is a means by which the potentially detrimental effects of a reduction in mean  $V_f$  can be partially counteracted.

### 8.1.3 Lower values of capillary density and C/F ratio:

In addition to the observed decreases in mean  $V_f$  and  $F_v$ , the transition zone is also characterized by a decrease of approximately 25% in capillary density, with respect to normal rat myocardium. This seems reasonable; if  $V_f$  (the number of vessels associated with each muscle fiber) is reduced by approximately 25%, and if there is no significant change in muscle fiber diameter, then one would expect to find a decrease of similar magnitude in capillary density.

C/F ratio was calculated from the quotient of mean  $V_f$  and mean  $F_v$ . As the reduction in mean  $V_f$  in the transition zone was greater than the accompanying decrease in mean  $F_v$ , it is clear that the C/F ratio in the transition zone would be less than that calculated for healthy myocardium.

### 8.1.4 Tendency toward fiber hypertrophy and increased intercapillary distance

Mean muscle fiber diameter in the transition zone was slightly greater than the mean fiber diameter in healthy hearts, but this did not prove to be significant. Had a larger sample size been taken (i.e. more than 150 measurements for each animal), it is possible that this difference in mean fiber diameter would have become significant. In retrospect, measurement of muscle fiber diameters should perhaps have been further pursued in my experiments.

A marginal increase in fiber diameter in the transition zone could be explained by the presence of the necrosis, which, once scar formation is complete, is stiff and not contractile. Fibers adjacent to the lesion would have to exert a greater force of contraction to overcome the increased tissue resistance caused by the scar (Dusek et al.,

1971).

A slight increase in mean intercapillary distance was also measured in the transition zone, but this again did not prove to be statistically significant. The reduction in mean  $V_f$  (and capillary density) in the transition zone, combined with the tendency toward fiber hypertrophy, suggest that an increase in mean intercapillary distance should have been expected. However, as mentioned previously, the accompanying reduction in mean  $F_v$  served to partially counteract the effects of reduced capillary supply and fiber hypertrophy by producing a more homogeneous distribution of intercapillary distances.

#### 8.2 Implications and Importance of the Transition Zone

The question of whether or not these changes in microvascular supply and capillary-fiber geometry significantly affect oxygen delivery to the transition zone was discussed in detail in the fourth chapter.

Application of the Krogh Cylinder Model to my data predicts that:

(1) under normal conditions of oxygen demand, the transition zone is in no danger of becoming anoxic. This is a reasonable conclusion; muscle fibers in the transition zone were found to be viable, as detected by NADPH diaphorase staining.

(2) if the rate of myocardial oxygen consumption is increased by a factor of 1.5x, tissue at the venous end of the capillary network, located at the boundary of adjacent tissue cylinders, is in danger of becoming anoxic.

It is difficult to verify these predictions with in vivo measurements of myocardial  $pO_2$  under varying conditions of oxygen demand. However, if they are valid, these predictions support the

idea that a 'margin of safety' has been lost in the transition zone. That is, a 25% reduction in capillary supply can be tolerated under normal metabolic conditions, but may be detrimental when myocardial oxygen demand is greatly increased.

A logical question arising from this discussion is: how important is the presence (or absence) of the transition zone to the continued function of the infarcted heart? Does the transition zone constitute a significant proportion of the heart and, since the fibers in the transition zone are viable, is it necessary to 'salvage' this region?

The transition zone was found to extend a minimum of 375  $\mu\text{m}$  laterally from the edge of the necrosis (refer to Chapter Four). Assuming that the rat heart is a sphere of given outer diameter and wall thickness, and the size of the necrosis is known (figure 24), the per cent volume of myocardium occupied by the transition zone can easily be estimated. This calculation indicates that the transition zone constitutes in the order of two per cent of the muscle volume of the 'typical' infarcted rat heart, five weeks following occlusion of the left coronary artery. As the left ventricular free wall accounts for approximately 60% of the total muscle mass of the rat heart (Turek et al., 1978), this suggests the transition zone occupies slightly more than four per cent of the wall of the left ventricle.

The extent of the transition zone may appear to be negligible, but this does not necessarily imply that it is insignificant. Should myocardial oxygen demand increase to the point at which fibers in the transition zone become anoxic, the boundaries of the necrosis will further be extended. At some critical point, when the size of the

Figure 24: Calculation of the % volume of the myocardial wall occupied by the transition zone.

\*Note: By assuming that the rat heart is a sphere, the total volume of the myocardial wall is over-estimated. (i.e. Since the density of muscle  $\approx 1 \text{ gm/cm}^3$ , this implies the rat heart weighs  $\approx 2 \text{ gm}$ ; in fact, the hearts weighed on the order of 1.1 to 1.2 gm.) Thus, the transition zone actually occupies slightly less than 2% of the heart, or 4% to 5% of the volume of the left ventricular wall.

X-Section:

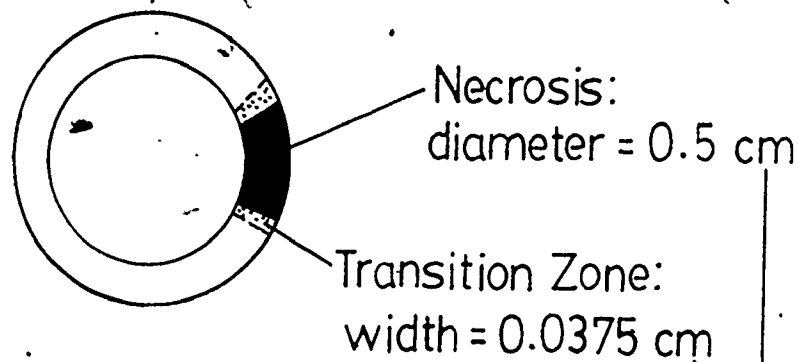

Front View:

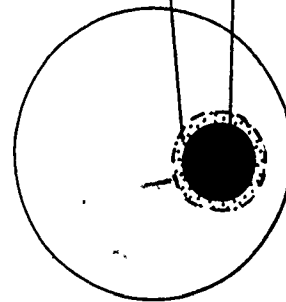

Outer diameter of heart = 2.0 cm  
 Wall thickness = 0.20 cm

∴ Total volume of myocardial wall =  $2.04 \text{ cm}^3$

Volume of transition zone =  $0.02 \text{ cm}^3$

∴ Transition zone occupies  $\approx 1\%$  of the myocardial wall.\*

lesion is such that the contractility of the ventricle is greatly compromised and cardiac output cannot be maintained, even such a small increase in the size of the necrosis may prove fatal to the animal.

Although its clinical importance may be questioned, the transition zone, because of its subnormal microvascular supply, represents a convenient in vivo model for the study of factors which promote or govern capillary growth. Evidence from the literature indicates that exercise can act as a stimulus for capillary growth in skeletal muscle and healthy myocardium, and exerts a protective effect on the heart when administered prior to the induction of an MI (refer to Chapter Five). The second objective of my thesis was to determine whether exercise can also stimulate revascularization in the transition zone of infarcted rat hearts.

### 8.3 Exercise and Revascularization in the Transition Zone

I found that, under certain conditions, voluntary exercise administered following coronary artery occlusion is associated with significant improvements in capillary supply and capillary-fiber geometry in the transition zone. It is interesting to note that the intensity at which normal rats must exercise to initiate neovascularization in skeletal muscle or healthy myocardium (approximately 85%  $\dot{V}O_2$  max) is considerably greater than the exercise intensity at which the exercised MI's demonstrated significant revascularization in the transition zone (60% to 64%  $\dot{V}O_2$  max). In healthy animals, the microvascular supply to the heart and muscles is more than adequate for their usual range of activities, and a substantial increase in

oxygen demand must occur before the growth of new capillaries is required. For example, in my experiments, healthy rats running at a mean intensity of approximately 63%  $\text{VO}_2$  max demonstrated no significant increase in myocardial capillary supply; this did not provide a sufficient stimulus for capillary growth in normal hearts. In the transition zone, however, the potential for oxygen supply to the tissue has been reduced significantly. As a result, an exercise intensity of only 60% to 64%  $\text{VO}_2$  max becomes an effective stimulus for revascularization under these circumstances.

Based on the results of my voluntary exercise studies, important factors in the revascularization of the transition zone include:

(1) an intermediate total distance run. Recall that rats in group A (six days per week x four weeks) that ran a total distance of between five and ten km during the month restored values of mean  $V_f$ ,  $F_v$  and C/F ratio which did not differ significantly from those found in healthy rat hearts. In contrast, animals running less than five km or more than 10 km during the four weeks did not demonstrate significant improvements in capillary supply in the transition zone.

(2) a balance between exercise frequency and mean running speed. When animals were exercised only three days per week for the month (group B), maximum improvements in microvascular supply were observed at the same total distance run as those animals in group A that exhibited significant increases in  $V_f$ ,  $F_v$  and C/F ratio. As animals in group B were only exercised half as often as rats in group A, this indicates that animals in group B had to run at twice the mean speed as their counterparts in group A to produce the same degree of



revascularization in the transition zone.

(3) regular reinforcement of the exercise periods. When the results for exercise groups B and C (six days per week x two weeks, followed by two sedentary weeks) were compared, only animals in group B demonstrated significant improvements in capillary supply, yet both groups of rats had been in the exercise wheels for the same total amount of time. When the final group of rats (D) were killed immediately after two weeks of daily exercise, evidence of revascularization in the transition zone was detected. This suggests that improvements associated with the two weeks of exercise for the animals in group C had regressed during the two weeks of inactivity.

(4) intermediate total distance run, a balance between exercise frequency and mean running speed, and regular reinforcement of the exercise periods were found to be especially important for the initiation and maintenance of improved values of  $V_f$  and C/F ratio in the transition zone. In contrast, conditions required to alter capillary-fiber geometry were not as specific. This is implied by the fact that peaks in the curves of  $F_v$  as a function of distance run were consistently broader than those for  $V_f$  or C/F ratio, and improvements in mean  $F_v$  persisted when increases in  $V_f$  and C/F ratio had regressed (i.e. during the two weeks animals in group C were not exercised).

From the addition of the forced exercise protocol, it was learned that:

(5) forced exercise is not an effective means of producing improvements in mean  $V_f$  and C/F ratio in the border zone. This is in contrast to the findings of the voluntary exercise studies.

(6) changes in mean  $F_v$  as a function of distance run for rats in

the forced exercise regime are in good agreement with those of the corresponding voluntary exercise protocol. This reinforces the concept that the conditions required to change capillary-fiber geometry are not as specific as those needed to stimulate capillary growth.

#### 8.4 Possible Stimuli for Capillary Growth

A conspicuous omission in the thesis to this point is some mention of the means by which exercise produced the observed improvements in microvascular supply - and fails to stimulate capillary growth in certain other cases. "The question which has puzzled so many observers as to the factors responsible for the formation of new capillaries still remains a matter of speculation" (Clark and Clark, 1939). This statement appears to be as valid today as it was 43 years ago.

Three factors thought to be responsible for, or contribute to, capillary growth have been mentioned in the literature:

- (1) local tissue hypoxia.
- (2) mechanical expansion, or 'friction' (shear stress) in the microcirculation.
- (3) the presence of a specific but unknown chemical substance.

Evidence associating each of these three factors with instances of capillary growth will be discussed in turn.

##### 8.4.1 Hypoxia

Roux (1895) first suggested that an increase in the metabolic demand of the tissue is the stimulus for capillary growth. More recently, Leon et al. (1968) stated that ". . . myocardial hypoxia,

due to the increased metabolic demand of the heart during exercise, may actually serve as the stimulus for the observed vascular changes".

Other authors, including Tomanek (1970), Bloor et al. (1970), and Hudlicka (1982) have implicated hypoxia as a possible stimulus for capillary growth.

Evidence presented in the literature indicates that exposure of animals to a hypoxic environment has in some cases been associated with an increase in capillary supply to the left ventricle. For example, Miller and Hale (1970) observed a significant increase in capillary density in the left ventricles of rats exposed continuously for eight weeks to a simulated altitude of 5,400 meters ( $pO_2 = 85$  mm Hg)\*. Valdiva (1962) found that guinea pigs born at an altitude of 4,268 meters ( $pO_2 = 97$  mm Hg), or exposed to this altitude for up to six months, exhibited a 10% increase in the value of C/F ratio in the left ventricle. Similarly, Becker et al. (1955) noted that puppies born at 6,097 meters ( $pO_2 = 78$  mm Hg) had a greater per cent surface area of the myocardium occupied by capillaries than was found in the controls born at sea level. Lund et al. (1980) also concluded that capillary growth had occurred in the left ventricles of rats exposed for six weeks to a simulated altitude of 6,100 meters ( $pO_2 = 78$  mm Hg).

---

\*  $pO_2$  for a given altitude was calculated from the following relationships:

$$\text{and } \begin{aligned} h_m &= 67.4 (T) \log (p_o/p) & h_m &= \text{altitude in meters} \\ pO_2 &= 0.21 (p) & T &= \text{temperature in K} \\ & & p_o &= 760 \text{ mm Hg} \\ & & p &= \text{atmospheric pressure at } h_m \end{aligned}$$

T.M. Yarwood & F. Castle, Physical and Mathematical Tables.  
London: Macmillan & Co. Ltd., 1974, -pg. 24.

Intermittent exposure to more severe hypoxic conditions also appears to be an effective means of increasing the myocardial vascular supply. Kerr et al. (1965) subjected rats to a simulated altitude of 22,000 feet (6,700 meters;  $pO_2 = 67$  mm Hg), two hours per day for a total of 15 days, and filled the coronary vasculature with an acrylic casting compound, using the method of Stevenson et al. (1964). The ratio of coronary cast weight/heart weight was found to be significantly greater in the altitude-exposed rats than in the controls; thus, the authors concluded that intermittent exposure to hypoxia produced a significant increase in the capacity of the coronary vascular tree. As with the studies of Stevenson et al. (1964), it should be remembered that the casting compound may not have penetrated to the capillary level, implying that the increase in the ratio of cast weight/heart weight primarily reflects growth (or an increase in diameter) of the coronary arteries, arterioles, venules and veins.

In contrast to these findings, Clark et al. (1978) found no evidence of capillary proliferation in the left ventricles of rats exposed for 34 days to a simulated altitude of approximately 6,000 meters ( $pO_2 = 80$  mm Hg). They concluded that the healthy myocardium is more than adequately supplied with capillaries, and that capillary density should not be expected to change in response to chronic hypoxia. In addition, Clark et al. (1978) pointed out apparent weaknesses in experiments which contradicted their findings. For example, the increased area occupied by capillaries observed by Becker et al. (1955) could be solely due to capillary dilatation, and not the growth of new vessels. This implies, however, that capillaries have the capacity to dilate and contract, a concept which has not been

conclusively proven to date. They also noted that Miller and Hale (1970) visualized the myocardial capillaries by dye injection, and obtained a value of capillary density in control animals (1,461 per  $\text{mm}^2$ ) which is considerably less than the accepted values previously presented in the literature (refer to table 1). This suggests that their injection method did not fill the microvasculature completely, and casts doubt on the increased density measurements they obtained in response to hypoxia. It should be noted, however, that Clark et al. (1978) based their own conclusions on hearts injected with India Ink, a method with the same shortcomings and weaknesses as the procedure used by Miller and Hale (1970).

Turek et al. (1972) also observed no significant increase in myocardial capillary density or C/F ratio in rats continuously exposed to a simulated altitude of 3,500 meters ( $pO_2 = 106 \text{ mm Hg}$ ) for a total of 29 days. While these results do not agree with those of Miller and Hale (1970), Valdiva (1962), Becker et al. (1955), Lund et al. (1980) and Kerr et al. (1965), the discrepancy is probably due to the shorter exposure time and higher  $pO_2$  used by Turek et al. (1972). These conditions did not provide an adequate stimulus for capillary growth in healthy rat hearts.

Recall from Chapter Five that exercise administered prior to the induction of an MI exerts a protective influence on the heart; exposure of animals to conditions of hypobaric hypoxia appears to provide similar protection to the myocardium.

Prior to coronary artery occlusion, Meenson et al. (1973) exposed a group of rats to a simulated altitude of 6,000 meters, five hours per day for eight weeks. The mortality rate in the experimental

group was reduced by a factor of five to six times, and the epicardial surface area of the lesions was approximately 35% smaller than those observed in MI's not exposed to hypoxic conditions. Similarly, Turek et al. (1980) found that five to seven weeks of constant exposure to a simulated altitude of 6,000 meters reduced the extent of necrotic lesions produced either by left coronary artery occlusion or injection of isoproterenol. McGrath et al. (1975) subjected rats to a simulated altitude of 7,000 meters ( $pO_2 = 64$  mm Hg), four hours per day for four weeks prior to the injection of isoproterenol. The myocardium of the animals exposed to the hypoxic conditions proved to be "... markedly resistant to the necrogenic effects of isoproterenol". That is, both the extent of the necrotic lesions and the mortality rate were lower in the altitude-exposed rats.

In contrast, Turek et al. (1980) observed that five to seven weeks of chronic exposure to 3,500 meters ( $pO_2 = 106$  mm Hg), or intermittent exposure to 6,000 meters, did not protect the hearts of rats from MI induced by isoproterenol or coronary artery ligation. It is possible that chronic exposure to a simulated altitude of 3,500 meters is not sufficient to stimulate protective adaptations in the myocardium. Intermittent exposure to 6,000 meters must either be of longer duration (i.e. eight weeks, as in the study of Meerson et al., 1973), or modified to chronic exposure to become effective.

The means by which hypobaric hypoxia protects the heart from myocardial infarction is not known. It may initiate capillary growth or cause an increase in the size of the coronary vascular tree (Turek et al., 1980; Meerson et al., 1973), increase the efficiency of anaerobic glycolysis in the heart (McGrath et al., 1975; Turek et al.,

1980), or increase the oxygen carrying capacity of the blood (Turek et al., 1980). I find it interesting that both exercise and exposure to hypoxic conditions can reduce the extent of damage caused by MI, and both are associated with capillary growth in the myocardium.

#### 8.4.2 Mechanical expansion or 'friction' (shear stress)

As early as 1893, Thoma postulated that capillaries grow in response to mechanical expansion of the microvascular bed, caused by an increase in blood pressure. If blood pressure is the determining factor in the formation of new capillaries, one would anticipate that more capillary sprouts would form from arterioles or at the arteriolar end of the capillary bed, rather than at the venular end (Clark and Clark, 1939). To date, this statement does not appear to have been proven. If mechanical expansion of the microvascular bed is involved in capillary growth, it should also be possible to elicit neovascularization by inducing long term vasodilation (Hudlicka, 1982). This has in fact been observed in skeletal muscles of rats treated with potent vasodilatory agents (Wright et al., 1981).

Clark (1918) suggested that neovascularization is induced by friction (i.e. shear stress) between the flowing blood and the endothelial cells. Similarly, Branemark hypothesized that the pulsatile movement of erythrocytes in blind-ended capillary sprouts is important for the continued growth of new capillaries. It is interesting to note that capillary sprouts in chronically stimulated skeletal muscles were consistently observed at bends in pre-existing capillaries (Myrhage and Hudlicka, 1978). Perhaps damage to the endothelial cells at these sites induced their proliferation.

It has been suggested that increased coronary blood flow

could be a factor in stimulating capillary growth in the heart (Hudlicka, 1982), and may in turn explain the association between exercise and myocardial neovascularization. It must be remembered, however, that blood flow through the coronary vessels occurs almost exclusively during diastole. As heart rate increases, coronary blood flow also increases (Barnard et al., 1980; Stone, 1980; Klocke and Ellis, 1980), but the per cent time the heart spends in diastole is shortened. Perhaps the increased flow and distension of the capillaries does not last long enough at high heart rates to stimulate capillary growth (Hudlicka, 1982). Thus, at high heart rates, damage to the endothelial cells caused by increased blood flow may not be a plausible explanation for capillary growth in the myocardium (Hudlicka, 1982).

This implies that bradycardia (accompanied by an increase in the total duration of diastole) may be more inclined to promote capillary growth than tachycardia. Evidence in support of this idea was provided by Wright and Hudlicka (1981): when the heart rates of rabbits were maintained at approximately half their original value by chronic electrical pacing, increases of up to 70% in myocardial capillary density were observed. It is also interesting to note that naturally 'athletic' animals such as hares and wild rats have lower resting heart rates and higher values of myocardial capillary density than their domestic or laboratory counterparts (Wachtlova et al., 1965; Wachtlova et al., 1967). These data suggest that increased duration of coronary blood flow associated with an increased duration of diastole (a product of exercise training) is responsible for neovascularization in the myocardium.



While mechanical factors may play a role in capillary proliferation, this cannot be the universal stimulus for the growth of new vessels. Neovascularization has been observed in embryos, even after the removal of the heart (Clark, 1918), or chemical inhibition of heartbeat (Stockard, 1915). Thus blood pressure, pulsatile flow or shear stress do not explain embryonic capillary growth.

#### 8.4.3 Presence of an unknown chemical

Loeb (1893) suggested that the growth of new vessels is a "trophism", responding to the presence of a specific chemical substance. Perhaps a specific metabolite or compound, present in muscle and heart during conditions of hypoxia or exercise, acts directly on the endothelial cells to produce capillary sprouts, or stimulates increased blood flow which in turn promotes the growth of new vessels. Identification of such an agent offers the ideal explanation for capillary growth, but to date the nature of this chemical has not been documented.

#### 8.5 Hypothesis

By what means does exercise produce the observed improvements in capillary supply in the transition zone of MI's? No obvious answer to this question has been provided in the literature; however, I believe there are two possible theories that could explain my experimental results:

- (1) capillary growth in the transition zone is governed by 'friction' or shear stress in the microvasculature.

As the mean running speed of the animals in the exercise

protocols is increased, mean exercise intensity is also increased; this is associated with a larger value of exercising heart rate. The increase in exercising heart rate is accompanied by greater coronary blood flow (Barnard et al., 1980; Stone, 1980), thereby initially stimulating capillary proliferation by mechanical damage to the endothelial cells. At some critical value of heart rate, when total duration of diastole is decreased, the length of time the capillaries are subjected to distension and increased flow would no longer be sufficient to act as a stimulus for capillary growth. This explanation would account for the fact that only moderate exercise is associated with significant improvements in capillary supply. That is, a certain minimum increase in coronary blood flow is required to initiate improvements in  $V_f$ , but the stimulus for revascularization is no longer present at the higher heart rates because of the shortened duration of diastole.

Why was no evidence of capillary growth observed in the forced exercise protocol? Emotional stress associated with forced exercise (as mentioned by Leon et al., 1968 and Bloor et al., 1970) may have increased the heart rate above that caused by the exercise alone, to the point at which the duration of diastole was decreased, and the stimulus for capillary growth was not present.

Recall the idea that increased blood flow during resting bradycardia (a product of exercise training) may be responsible for capillary growth in the heart. In my experiments, I do not feel the MI's were exercising at an intensity sufficient to result in resting bradycardia. Even if bradycardia had resulted, then the animals exercising at the greatest intensity would be expected to demonstrate

the training effect, and the accompanying capillary growth. In fact, these rats exhibited no significant increase in capillary supply in the transition zone.

As it stands, the theory relating coronary blood flow to capillary growth does not explain why healthy rats must exercise at an intensity of 85%  $\dot{V}O_2$  max to initiate neovascularization in the myocardium, yet MI's running at 60% to 64%  $\dot{V}O_2$  max exhibit a significant increase in  $V_f$  in the transition zone. This implies that, at a given exercise intensity, the rate of blood flow is higher in the transition zone than in healthy myocardium. Recall that one of the three determinants of myocardial oxygen demand is contractility (Klocke and Ellis, 1980; Guyton and Cowley, 1976). If the contractility of the transition zone differs from that of normal myocardium, its oxygen consumption would also be expected to differ; this could result in a difference in blood flow to the border region. To my knowledge, no such comparison of contractilities, oxygen demand, or blood flow measurements between the transition zone and healthy myocardium has been presented.

(2) local tissue hypoxia stimulates neovascularization in the transition zone.

As heart rate increases, the rate of myocardial oxygen consumption also increases and, as a result, muscle fibers in the transition zone are in danger of becoming hypoxic (refer to Chapter Four). Perhaps metabolic hypoxia is the means by which capillary growth is initiated in the transition zone in response to exercise. Hypoxia could either have a direct effect on the endothelial cells, or, because of the shortage of oxygen or an accumulation of metabolites,

stimulate revascularization indirectly by increasing the rate of coronary blood flow.

This hypothesis implies that as mean running intensity increases, heart rate and therefore myocardial oxygen demand (and the hypoxic stimulus for capillary growth) also increase. It fails to explain why no significant increase in mean  $V_f$  occurred in rats in the voluntary exercise protocols that ran the greatest total distances, or in any of the animals in the forced exercise regime. Under these conditions, the heart rate, demand for oxygen, and thus the hypoxic stimulus should be greater than during more moderate voluntary exercise, when capillary growth in the transition zone was observed. Other factors counteracting the stimulus provided by metabolic hypoxia appear to have come into play.

It seems reasonable to assume that the actual process of capillary growth has a metabolic oxygen requirement. It also seems logical that the maintenance of tissue metabolism has priority over the growth of new vessels. Thus, at the higher heart rates, perhaps all of the limited oxygen supply is used to attempt to maintain the viability of the muscle fibers, and none remains for the initiation of new capillaries. If hypoxia promotes capillary growth indirectly by increasing coronary blood flow, it is possible that, as mentioned previously, the decreased duration of diastole at higher heart rates effectively removes the mechanical stimulus for revascularization.

While it is difficult to explain how hypoxia alone can account for both capillary growth in the transition zone in response to moderate exercise and the absence of capillary growth with more intense activity, the theory does explain why revascularization occurs

at lower exercise intensities in MI's than in healthy hearts. Since the capillary supply in the transition zone has been reduced, the degree of tissue hypoxia would be greater in this region than in normally perfused myocardium. Thus, a lower exercise intensity is required by MI's to produce hypoxic conditions of sufficient severity in the transition zone to initiate capillary growth.

Neither the theory of shear stress nor that of local tissue hypoxia offers a complete and plausible explanation for all the results obtained from my exercise experiments. Rather, I suspect that both metabolic tissue hypoxia and mechanical damage to the endothelium act together to promote capillary growth in the heart - i.e. the magnitude of the mechanical stimulus may be controlled by the degree of tissue hypoxia. The effectiveness of these two factors is limited by heart rate, or, more specifically, by the shortened duration of diastole associated with increased heart rate. At this critical point, the absence of the mechanical component of the stimulus overrides the influence of metabolic hypoxia, and capillary growth can no longer take place.

This entire line of reasoning is based on two simple assumptions:

(1) heart rate increases as the mean running speed of the animals increases.

(2) heart rate in animals forced to run at a given speed is greater than in animals running voluntarily at the same speed.

Confirmation of these assumptions by direct measurement of exercising heart rates would strengthen the hypothesis considerably.

While possible factors associated with capillary growth have

previously been discussed by other authors, no mechanisms to explain changes in capillary-fiber geometry have been offered. This is not surprising, as measurements of  $F_v$  in response to exercise, hypoxia, etc. have not appeared in the literature to date.

If the observed decrease in mean  $F_v$  in the transition zone represents an adaptation to equalize mean intercapillary distance and reduce the incidence of hypoxic pockets of tissue, then it is reasonable to propose that capillary-fiber geometry is sensitive to tissue  $pO_2$ . If this is true, then it would suggest that the growth of new capillaries (thereby reducing the degree of tissue hypoxia) should be accompanied by a return to normal capillary-fiber geometry. This was in fact observed in the voluntary exercise studies, in which increased values of mean  $V_f$  in the transition zone were accompanied by increases in mean  $F_v$  values.

This does not explain, however, why in some cases increases in mean  $F_v$  were observed in the transition zone without evidence of significant capillary growth (i.e. in the results of the forced exercise protocol, and group C of the voluntary exercise studies, in which significant improvements in mean  $F_v$  persisted even when increases in mean  $V_f$  had apparently regressed). If the value of  $V_f$  observed in the healthy rat heart contains the 'margin of safety' mentioned earlier in the discussion, perhaps a lower value of mean  $V_f$  than is normally found in the controls (but higher than the  $V_f$  value in the transition zone of unexercised MI's) is sufficient to increase tissue  $pO_2$  to the point at which the protective effect of the reduced mean  $F_v$  is no longer required. In other words, significant increases in mean  $F_v$  could precede (therefore be observed in the absence of) statistically

significant increases in mean  $V_f$ . Thus, this hypothesis could account for the results of the forced exercise regime, group C of the voluntary exercise studies, and the broad peaks observed consistently in the graphs of  $F_v$  as a function of distance run.

#### 8.6 Suggestions for Further Study

As has been mentioned at several points throughout the thesis, the two primary objectives of my research were:

(1) to determine whether or not a transition zone is present in an animal model of chronic myocardial infarction.

(2) to ascertain whether or not exercise can serve as a stimulus for revascularization in the transition zone.

I believe that both of these initial objectives have been met. However, in the process, many additional questions have been raised, and as a result, this project could easily be extended into a number of possible directions.

For example, in my experiments, values of  $V_f$ ,  $F_v$  and C/F ratio were measured five weeks following the occlusion of the left coronary artery. It would be interesting to measure changes in these variables, as well as the extent of the transition zone, as the necrosis evolves, (i.e. from six hours to five weeks following coronary artery ligation). This could be combined with a study of the capillary supply in the remaining 'normal' regions of the infarcted hearts. Since most clinical experiments concerned with salvaging the border zone use a canine model of MI, it might prove useful to perform a similar sort of study in the dog. In terms of the exercise studies, an infinite selection of exercise protocols could be tested to further define the

relationship between exercise and revascularization in the transition zone. Specifically, it would be interesting to determine whether improvements in mean  $V_f$ ,  $F_v$  and C/F ratio in response to four weeks of daily exercise are stable, or whether they would also regress if the animals were kept alive but no longer exercised.

I believe the most interesting (and most challenging) extension of my project would be an attempt to identify the factor(s) associated with exercise that stimulate capillary growth in the transition zone. For example, can the trends observed in mean  $V_f$ ,  $F_v$  and C/F ratio as a function of distance run be duplicated by subjecting a group of MI's to various hypoxic gas mixtures? If a positive correlation was observed between the results of these two experiments, this would not necessarily prove that certain levels of hypoxia act as a direct stimulus for capillary growth in the transition zone; many other factors may also be involved. However, if no improvement in capillary supply were produced, hypoxia could effectively be ruled out as a stimulus for revascularization, and other possible explanations (such as mechanical factors) could be pursued. This clearly represents an area worthy of further study:



APPENDIX: Anatomical Data

Initial Body Wt. (gm)	Final Body Wt. (gm)	Heart Wt. (gm)	Necrosis: % of Left Ventricle	Distance (km)
<u>CONTROLS (n=5)</u>				
180	250	1.00	-	-
201	354	1.05	-	-
195	287	1.00	-	-
225	367	0.98	-	-
225	359	1.15	-	-
<u>MI'S (n=7)</u>				
180	300	1.10	28%	-
200	357	1.25	26%	-
210	357	1.23	37%	-
246	327	1.12	23%	-
254	410	1.18	32%	-
160	344	1.15	26%	-
256	393	1.12	30%	-
<u>50's (n=2)</u>				
212	354	1.14	-	-
210	377	1.07	-	-
<u>EXERCISE GROUP 'A: 6 days/week x 4 weeks (n=17)</u>				
202	369	1.18	21%	2.13
215	389	1.27	30%	2.59
205	384	1.11	27%	2.78
209	367	1.20	32%	4.69
174	331	1.11	23%	4.90
161	376	1.15	25%	5.12
172	301	1.13	28%	6.20
160	301	1.14	31%	6.47
210	323	1.09	24%	8.18

Initial Body Wt. (gm)	Final Body Wt. (gm)	Heart Wt. (gm)	Necrosis: % of Left Ventricle	Distance (km)
<u>EXERCISE GROUP A: 6 days/week x 4 weeks (cont'd)</u>				
170	309	1.19	38%	8.30
182	343	1.20	29%	8.68
174 <sup>2</sup>	330	1.07	26%	9.97
185	320	1.21	30%	11.56
191	330	1.24	33%	12.86
180	359	1.23	26%	15.20
180	308	1.10	29%	24.94
203	356	1.19	25%	27.90
<u>EXERCISE GROUP B: 3 days/week x 4 weeks (n=9)</u>				
220	390	1.16	23%	2.27
222	379	1.12	24%	2.39
200	357	1.13	21%	2.81
234	381	1.09	24%	3.12
185	261	0.93	25%	7.16
177	300	1.03 <sup>2</sup>	32%	7.94
229	375	1.13	20%	8.24
202	282	1.01	27%	8.56
218	375	1.12	23%	14.84
<u>EXERCISE GROUP C: 6 days/week x 2 weeks + 2 sedentary weeks (n=12)</u>				
200	370	1.14	22%	0.96
209	382	1.26	28%	1.99
199	302	0.97	28%	2.28
221	398	1.25	27%	2.93
208	395	1.21	29%	3.29
214	357	1.16	23%	4.15
218	314	1.00	25%	4.31
222	396	1.20	24%	4.99
234	387	1.23	22%	5.49
206	384	1.19	22%	6.03

3 3

OF / DE

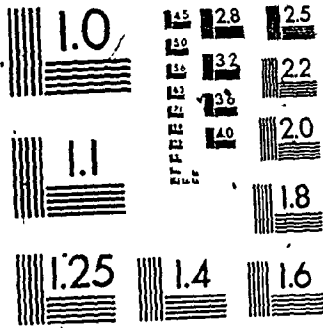

Initial Body Wt. (gm)	Final Body Wt. (gm)	Heart Wt. (gm)	Necrosis: % of Left Ventricle,	Distance (km)
--------------------------	------------------------	-------------------	-----------------------------------	------------------

---

EXERCISE GROUP C: 6 days/week x 2 weeks + 2 sedentary weeks (cont'd)

218	363	1.10	26%	8.29
213	355	1.23	31%	9.14

EXERCISE GROUP D: 6 days/week x 2 weeks (n=8)

234	321	0.97	28%	0.12
188	286	1.00	31%	2.01
183	275	1.02	30%	2.89
191	287	1.00	25%	3.82
193	289	1.04	35%	3.95
194	227	0.98	32%	4.80
194	279	1.08	29%	5.57
190	260	1.05	38%	7.76

EXERCISED CONTROLS (n=3)

225	376	0.98	-	4.66
225	359	1.15	-	8.58
217	315	1.05	-	21.66

REFERENCES

- Adolfsson, J., A. Ljungqvist, G. Tornling and G. Unge (1981). Capillary increase in the skeletal muscle of trained young and adult rats. *J. Physiol.* 310: 529 - 532.
- Andersen, P. and J. Hendriksson (1977). Capillary supply of the quadriceps femoris muscle of man: adaptive response to exercise. *J. Physiol.* 270: 677 - 690.
- Barlow, C.H. and B. Chance (1976). Ischemic areas in perfused rat hearts: measurement by NADH fluorescence photography. *Science* 193: 909 - 910.
- Barnard, R.J., H.W. Duncan, K.M. Baldwin, G. Grimditch and G.D. Buckberg (1980). Effects of intensive exercise training on myocardial performance and coronary blood flow. *J. Appl. Physiol.* 49: 444 - 449.
- Becker, E.L., R.G. Cooper and G.D. Hataway (1955). Capillary vascularization in puppies born at a simulated altitude of 22,000 feet. *J. Appl. Physiol.* 8: 166 - 168.
- Bell, R.D. and R.L. Rasmussen (1974). Exercise and the myocardial capillary-fiber ratio during growth. *Growth* 38: 237 - 244.
- Bloor, C.M. and A.S. Leon (1970). Interaction of age and exercise on the heart and its blood supply. *Lab. Invest.* 22: 160 - 165.
- Branemark, P.I. (1965). Capillary form and function. *Bibl. Anat.* 7: 9 - 28.
- Braunwald, E. (1971). Control of myocardial oxygen consumption: physiologic and clinical considerations. *Am. J. Cardiol.* 27: 429 - 433.
- Braunwald, E., P.R. Maroko and P. Libby (1974). Reduction of infarct size following coronary artery occlusion. *Circ. Res.* 34 - 35 (Suppl. III): III 192 - III 201.
- Brodal, P., F. Ingjer, and L. Hermansen (1977). Capillary supply of skeletal muscle fibers in untrained and endurance-trained men. *Am. J. Physiol.* 232: H705 - H712.
- Brown, M.D., M.A. Cotter, O. Hudlicka and G. Vrbova (1976). The effects of different patterns of muscle activity on capillary density, mechanical properties, and structure of slow and fast rabbit muscle. *Pflügers Arch.* 361: 241 - 250.
- Brown, R.E. (1965). The pattern of the microcirculatory bed in the ventricular myocardium of domestic mammals. *Am. J. Anat.* 116: 355 - 374.

- Buja, L.M. and J.T. Willerson (1981). Clinicopathologic correlates of acute ischemic heart disease syndromes. *Am. J. Cardiol.* 47: 343 - 356.
- Carrow, R.E., R.E. Brown and W.D. Van Huss (1967). Fiber sizes and capillary to fiber ratios in skeletal muscle of exercised rats. *Anat. Rec.* 159: 33 - 40.
- Clark, C., M.I. Foreman, K.A. Cane, F.M. McDonald and J.R. Parratt (1980). Coronary artery ligation in anesthetized rats as a method for the production of experimental dysrhythmias and for the determination of infarct size. *J. Pharm. Meth.* 3: 357 - 368.
- Clark, D.R. and P. Smith (1978). Capillary density and muscle fiber size in the hearts of rats subjected to simulated high altitude. *Cardiovasc. Res.* 12: 578 - 584.
- Clark, E.R. (1918). Studies on the growth of blood vessels in the tail of the frog larva - by observation and experiment on the living animal. *Am. J. Anat.* 23: 37 - 88.
- Clark, E.R. and E.L. Clark (1939). Microscopic observations on the growth of blood capillaries in the living mammal. *Am. J. Anat.* 64: 251 - 301.
- Cotter, M.A., O. Hudlicka and G. Vrbova (1973). Growth of capillaries during long-term activity in skeletal muscle. *Bibl. Anat.* 11: 395 - 398.
- Cox, J.L., V.W. McLaughlin, N.C. Flowers and L.G. Horan (1968). The ischemic zone surrounding acute myocardial infarction: its morphology as detected by dehydrogenase staining. *Am. Heart J.* 76: 650 - 659.
- Darrah, M.I. and R.L. Engen (1982). Beneficial effects of exercise on 1-isoproterenol induced myocardial infarction in male rats. *Med. Sci. Sports* 14: 76 - 80.
- Drury, R.A.B., E. Wallington and R. Cameron. Carleton's Histological Techniques. London: Oxford University Press, 1967.
- Dubowitz, V. and M.H. Brooke. Muscle Biopsy: A Modern Approach. Toronto: W.B. Saunders Co. Ltd., 1973.
- Dusek, J., G. Rona and D.S. Kahn (1971). Healing process in the marginal zone of an experimental myocardial infarction. *Am. J. Path.* 62: 321 - 338.
- Factor, S.M., E. Sonnenblick and E.S. Kirk (1978). The histologic border zone in acute myocardial infarction - islands or peninsulas? *Am. J. Path.* 92: 111 - 120.
- Factor, S.M., E.M. Okun and E.S. Kirk (1981). The histologic lateral border of acute canine myocardial infarction: a function of microcirculation. *Circ. Res.* 48: 640 - 649.

- Fine, G., A. Morales and J.R. Scirpella (1966). Experimental myocardial infarction. *Arch. Path.* 82: 4 - 8.
- Fishbein, M.C., D. Maclean and P.R. Maroko (1978). Experimental myocardial infarction in the rat: qualitative and quantitative changes during pathologic evolution. *Am. J. Path.* 90: 57 - 70.
- Fishbein, M.C., C.A. Hare, S.A. Gissen, J. Spadaro, D. Maclean and P.R. Maroko (1980). Identification and quantification of histochemical border zones during the evolution of myocardial infarction in the rat. *Cardiovasc. Res.* 14: 41 - 49.
- Fletcher, J.E. (1978). Mathematical modeling of the microcirculation. *Math Biosci.* 38: 159 - 202.
- Fletcher, P.J., J.M. Pfeffer, M.A. Pfeffer and E. Braunwald (1981). Left ventricular diastolic pressure-volume relations in rats with healed myocardial infarction. *Circ. Res.* 49: 618 - 626.
- Folkow, B. and E. Neil. *Circulation*. London: Oxford University Press, 1971.
- Gray, S.M. and E.M. Renkin (1978). Microvascular supply in relation to fiber metabolic type in mixed skeletal muscles of rabbits. *Microvasc. Res.* 16: 406 - 425.
- Guski, H. (1980). The effect of exercise on myocardial interstitium: an ultrastructural morphometric study. *Exp. Path.* 18: 141 - 150.
- Guyton, A.C. and A.W. Cowley. *International Review of Physiology Volume 9: Cardiovascular Physiology II*. Baltimore: University Park Press, 1976.
- Halpern, M.H. (1953). Extracoronary cardiac veins in the rat. *Am. J. Anat.* 92: 307 - 327.
- Halpern, M.H. (1957). The dual-blood supply of the rat heart. *Am. J. Anat.* 101: 1 - 16.
- Harken, A.H., C.H. Barlow, W.R. Harden and B. Chance (1978). Two and three dimensional display of myocardial ischemic 'border zone' in dogs. *Am. J. Cardiol.* 42: 954 - 959.
- Hearse, D.H. and D.M. Yellon (1981). The 'border zone' in evolving myocardial infarction: controversy or confusion? *Am. J. Cardiol.* 47: 1321 - 1334.
- Hebel, R. and M.R. Stromberg. *Anatomy of the Laboratory Rat*. Baltimore: The Williams and Wilkins Co., 1976.
- Henquell, L. and C.R. Honig (1976). Intercapillary distances and capillary reserve in right and left ventricles: significance for control of tissue  $pO_2$ . *Microvasc. Res.* 12: 35 - 41.



- Hillis, D.L. and E. Braunwald (1977). Myocardial ischemia - the effects of ischemia on myocardial contractility. *N. Engl. J. Med.* 296: 971 - 978.
- Hort, W. (1955). Quantitativ untersuchungen über die capillarisation des herzmuskels in erwachsenen- und griesenalter, bei hypertrophie und hyperplasie. *Virchows Arch.* 327: 560 - 570.
- Hort, W. (1971). Quantitative morphology and structural dynamics of the myocardium. *Meth. Achiev. Exp. Path.* 5: 3 - 21.
- Hudlicka, O. (1982). Growth of capillaries in skeletal and cardiac muscle. *Circ. Res.* 50: 451 - 460.
- Ichikawa, H. and O. Matsubara (1977). Studies on the microvasculature of the human myocardium. *Bull. Tokyo Med. Dent. Univ.* 24: 53 - 65.
- Ingjer, F. and P. Brodal (1978). Capillary supply of skeletal muscle fibers in endurance trained and untrained women. *Eur. J. Appl. Physiol.* 38: 291 - 299.
- Jacobs, T.B., R.D. Bell, J.D. McClements and W.B. Firor (1980). The positive influence of exercise intensity and duration on the development of myocardial vascularity. Canadian Cardiovascular Society 33rd Annual Meeting; 33.
- Janse, M.J., J. Cincia, H. Morena, J.W.T. Fiolet, A.G. Kleber, G.P. deVries, A.E. Becker and D. Durrier (1977). The 'border zone' in myocardial ischemia: an electrophysiological, metabolic and histochemical correlation in the pig heart. *Circ. Res.* 44: 576 - 588.
- Johns, T.N.P. and B.J. Olson (1954). Experimental myocardial infarction: a method for coronary artery occlusion in small animals. *Ann. Surg.* 140: 675 - 682.
- Kavanaugh, T., R.J. Shephard, A.W. Chisholm, S. Qureshi and J. Kennedy (1979). Prognostic indexes for patients with ischemic heart disease enrolled in an exercise-centered rehabilitation program. *Am. J. Cardiol.* 44: 1230 - 1240.
- Kentala, E. (1972). Physical fitness and feasibility of physical rehabilitation after myocardial infarction in men of working age. *Ann. Clin. Res.* 4 (Suppl. 9): 1 - 83.
- Kerr, A., R.B. Diasio and W.J. Bommer (1965). Effect of altitude (hypoxia) on coronary artery size in the white rat. *Am. Heart J.* 69: 841.
- Klocke, F.J. and A.K. Ellis (1980). Control of coronary blood flow. *Ann. Rev. Med.* 31: 489 - 508.

- Krogh, A. (1919). The supply of oxygen to the tissues and the regulation of the capillary circulation. *J. Physiol.* 52: 457 - 474.
- Leon, A.S. and C.M. Bloor (1968). Effects of exercise and its cessation on the heart and its blood supply. *J. Appl. Physiol.* 24: 485 - 490.
- Ludwig, G. (1971). Capillary pattern of the myocardium. *Meth. Achiev. Exp. Path.* 5: 238 - 271.
- Lund, D.D. and R.J. Tomanek (1980). The effects of chronic hypoxia on the myocardial cell of normotensive and hypertensive rats. *Anat. Rec.* 196: 421 - 430.
- Maclean, D., M.C. Fishbein, E. Braunwald and P.R. Maroko (1978). Long-term preservation of ischemic myocardium after experimental coronary artery occlusion. *J. Clin. Invest.* 61: 541 - 551.
- Mai, J.V., V.R. Edgerton and R.J. Barnard (1970). Capillarity of red, white and intermediate muscle fibers in trained and untrained guinea pigs. *Experientia* 26: 1222 - 1223.
- Mallory, G.K., P.D. White and J. Salcedo-Salgar (1939). The speed of healing of myocardial infarction. *Am. Heart J.* 18: 647 - 671.
- Maroko, P.R., J.K. Kjekshus and B.E. Sobel (1971). Factors influencing infarct size following experimental coronary artery occlusion. *Circulation* 43: 67 - 82.
- Maroko, P.R., L.D. Hillis and J.E. Muller (1977). Favorable effects of hyaluronidase on electrocardiographic evidence of necrosis in patients with acute myocardial infarction. *N. Engl. J. Med.* 296: 898 - 903.
- Martini, J., and C.R. Honig (1969). Direct measurement of intercapillary distance in beating rat heart *in situ* under various conditions of O<sub>2</sub> supply. *Microvasc. Res.* 1: 244 - 256.
- Martini, J., C.L. Odoroff and C.R. Honig (1974). Dual effect of oxygen on magnitude and uniformity of coronary intercapillary distance. *Am. J. Physiol.* 226: 800 - 810.
- McElroy, C.L., S.A. Gissen and M.C. Fishbein (1978). Exercise-induced reduction in myocardial infarct size after coronary artery occlusion in the rat. *Circulation* 57: 958 - 962.
- McGrath, J.J., B. Ostadal, J. Prochazka, M. Wachtlova and V. Rychterova (1975). Experimental cardiac necrosis in hypobaric and anemic hypoxia. *J. Appl. Physiol.* 39: 205 - 208.
- Meerson, F.Z., O.A. Gomzakov and M.A. Shimkovich (1973). Adaptation to high-altitude hypoxia as a factor preventing development of myocardial ischemic necrosis. *Am. J. Cardiol.* 31: 30 - 33.

Miller, A.T. and D. Hale (1970). Increased vascularity of brain, heart and skeletal muscle of polycythemic rats. *Am. J. Physiol.* 219: 702 - 704.

Muir, A.R. The Mammalian Heart. London: Oxford University Press, 1971.

Myrhaeg, R. and O. Hudlicka (1978). Capillary growth in chronically stimulated adult skeletal muscle as studied by intravital microscopy and histological methods in rabbits and rats. *Microvasc. Res.* 16: 73 - 90.

Okun, E.M., S.M. Factor and E.S. Kirk (1979). End-capillary loops in the heart: an explanation for discrete myocardial infarctions without border zones. *Science* 206: 565 - 567.

Plyley, M.J. and A.C. Groom (1975). Geometrical distribution of capillaries in mammalian striated muscle. *Am. J. Physiol.* 228: 1376 - 1383.

Rakusan, K. (1971a). Quantitative morphology of capillaries in the heart - number of capillaries in animal and human hearts under normal and pathological conditions. *Meth. Achiev. Exp. Path.* 5: 272 - 286.

Rakusan, K. Oxygen in the Heart Muscle. Springfield: Charles C. Thomas (Publisher), 1971b.

Reimer, K.A. (1980). Myocardial infarct size: measurements and predictions. *Arch. Path. Lab. Med.* 104: 225 - 230.

Riggs, C.E., C.W. Landiss, G.T. Jessup and H.W. Bonner (1977). Effects of exercise on the severity of isoproterenol-induced myocardial infarction. *Med. Sci. Sports* 9: 83 - 87.

Roberts, J.T. and J.T. Wearn (1941). Quantitative changes in the capillary-muscle relationship of human hearts during normal growth and hypertrophy. *Am. Heart J.* 21: 617 - 633.

Roux, W. Gesammelte Abhandlungen der Entwicklungsmechanik der Organismus. Leipzig: Engelmann, 1895.

Selye, H. E. Bajusz, S. Grasso and P. Mendell (1960). Simple techniques for the surgical occlusion of coronary vessels in the rat. *Angiology* 11: 398 - 407.

Shephard, R.J. (1979). Recurrence of myocardial infarction in an exercising population. *Br. Heart J.* 41: 133 - 138.

Shephard, R.J. (1980). Exercise and recurrence of myocardial infarction. *Am. Heart J.* 100: 404 - 405.

Shepherd, J.E. and P.D. Gollnick (1976). Oxygen uptake of rats at different work intensities. *Pflügers Arch.* 362: 219 - 222.

- Sillau, A.H. and N. Banchemo (1977). Visualization of capillaries in skeletal muscle by the ATPase reaction. *Pflügers Arch.* 369: 269 - 271.
- Simson, M.B., W. Harden, C. Barlow and A.H. Harken (1979). Visualization of the distance between perfusion and anoxia along an ischemic border. *Circulation* 60: 1151 - 1155.
- Sivarajan, E., R.A. Bruce, T.M. Almes, B. Green, L. Belanger, B.D. Lindskog, K.M. Newton and L.W. Mansfield (1981). In-hospital exercise after myocardial infarction does not improve treadmill performance. *N. Engl. J. Med.* 305: 357 - 362.
- Spadaro, J., M.C. Fishbein, C. Hare, M.A. Pfeffer and P.R. Maroko (1980). Characterization of myocardial infarcts in the rat. *Arch. Path. Lab. Med.* 104: 179 - 183.
- Steinhausen, M., H. Tillmans and H. Thederan (1978). Microcirculation of the epimyocardial layer of the heart: a method for *in vivo* observation of the microcirculation of superficial ventricular myocardium of the heart and capillary flow pattern under normal and hypoxic conditions. *Pflügers Arch.* 378: 9 - 14.
- Stevenson, J.A.F., V. Feleki, P. Rechnitzer and J.R. Beaton (1964). Effect of exercise on coronary tree size in the rat. *Circ. Res.* 15: 265 - 269.
- Stockard, C.R. (1915). The origin of blood and vascular endothelium in embryos without a circulation of the blood and in the normal embryo. *Am. J. Anat.* 18: 227 - 327.
- Stone, H.L. (1980). Coronary blood flow, myocardial oxygen consumption and exercise training in dogs. *J. Appl. Physiol.* 49: 759 - 768.
- Sugano, S., N. Oshino and B. Chance (1974). Mitochondrial functions under hypoxic conditions: the steady states of cytochrome c reduction and of energy metabolism. *Biochem. Biophys. Acta.* 347: 340 - 358.
- Tepperman, J. and D. Pearlman (1961). Effects of exercise and anemia on coronary arteries of small animals as revealed by the corrosion-cast technique. *Circ. Res.* 9: 576 - 584.
- Thews, G. Gaseous diffusion in the lungs and tissues. In Reeve, E.B. and A.C. Guyton (Ed.) Physical Basis of Circulatory Transport: Regulation and Exchange. Philadelphia: Saunders, 1967.
- Thoma, R. Untersuchungen über die Histogenese und Histomechanik des Gefäßsystems. Stuttgart, 1893.
- Tittel, K., W. Knacke, B. Brauer and H. Otto (1966). Der Einfluss körperlicher belastungen unterschiedlicher dauer und intensität auf die Kapillarisation der Herz- und Skelettmuskulatur bei Albino-Ratten. XVI Weltkongress für Sportmedizin: 181 - 189.

- Tomanek, R.J. (1970). Effect of age and exercise on the extent of the myocardial capillary bed. *Anat. Rec.* 167: 55 - 62.
- Turek, Z., M. Grandtner and F. Kreuzer (1972). Cardiac hypertrophy, capillary and muscle fiber density, muscle fiber diameter, capillary radius and diffusion distance in the myocardium of growing rats adapted to a simulated altitude of 3,500 meters. *Pflügers Arch.* 335: 19 - 28.
- Turek, Z., M. Grandtner, K. Kubat, B.E.M. Rignalda and F. Kreuzer (1978). Arterial blood gases, muscle fiber diameter and intercapillary distance in cardiac hypertrophy of rats with an old myocardial infarction. *Pflügers Arch.* 376: 209 - 215.
- Turek, Z., K. Kubat, B.E.M. Rignalda and F. Kreuzer (1980). Experimental myocardial infarction in rats acclimatized to simulated high altitude. *Basic Res. Cardiol.* 75: 544 - 553.
- Valdiva, E. (1962). Total capillary bed of the myocardium in chronic hypoxia. *Fed. Proc.* 21: 221.
- Wachtlova, M., K. Rakusan and O. Poupa (1965). The coronary terminal vascular bed in the heart of the hare (*Lepus europeus*) and the rabbit (*Oryctolagus domesticus*). *Physiol. Bohemoslov.* 14: 627 - 633.
- Wachtlova, M., K. Rakusan, Z. Roth and O. Poupa (1967). The terminal vascular bed of the myocardium in the wild rat (*Rattus norvegicus*) and the laboratory rat (*Rattus norvegicus lab*). *Physiol. Bohemoslov.* 16: 548 - 554.
- Wearn, J.T. (1928). The extent of the capillary bed in the heart. *J. Exp. Med.* 47: 273 - 292.
- Wexler, B.C. and B.P. Greenberg (1976). Effects of exercise on myocardial infarction in young vs. old male rats: electrocardiographic changes. *Am. Heart J.* 88: 343 - 350.
- Wilhelmsen, L., H. Sanne, D. Elmfeldt, G. Grimby, G. Tibblin and H. Wedel (1975). A-controlled trial of physical training after myocardial infarction: effects of risk factors, nonfatal reinfarction and death. *Prevent. Med.* 4: 491 - 508.
- Wright, A.J.A. and O. Hudlicka (1981). Capillary growth and changes in heart performance induced by chronic bradycardial pacing in the rabbit. *Circ. Res.* 49: 469 - 478.
- Wright, A.J.A., O. Hudlicka, K.R. Tyler and A. Ziada (1981). The effect of vasoactive drugs on capillary density and performance in skeletal muscle. *Bibl. Anat.* 20: 362 - 365.
- Yarwood, T.M. and F. Castle. Physical and Mathematical Tables. London: Macmillan and Co. Ltd., 1974.

Yellon, D.M., D.J. Hearse, R. Crome, J. Grannell and R.K.H. Wyse (1981). Characterization of the lateral interface between normal and ischemic tissue in the canine heart during evolving myocardial infarction. Am. J. Cardiol. 47: 1233 - 1239.

Zweifach, B.W. (1959). The microcirculation of the blood. In: Vertebrate Structures and Functions: Readings from Scientific American. San Francisco: W.H. Freeman and Co., 1974; 107 - 113.

**END**

1 | 6 | 0 | 9 | 8 | 3

**FIN**