Electronic Thesis and Dissertation Repository

12-3-2013 12:00 AM

A Study of Faunal Consumption at the Gallinazo Group Site, Northern Coast of Peru

Claire Venet-Rogers
The University of Western Ontario

Supervisor
Dr. Lisa Hodgetts
The University of Western Ontario

Graduate Program in Anthropology
A thesis submitted in partial fulfillment of the requirements for the degree in Master of Arts
© Claire Venet-Rogers 2013

Follow this and additional works at: <https://ir.lib.uwo.ca/etd>



Part of the [Archaeological Anthropology Commons](#)

Recommended Citation

Venet-Rogers, Claire, "A Study of Faunal Consumption at the Gallinazo Group Site, Northern Coast of Peru" (2013). *Electronic Thesis and Dissertation Repository*. 1749.
<https://ir.lib.uwo.ca/etd/1749>

This Dissertation/Thesis is brought to you for free and open access by Scholarship@Western. It has been accepted for inclusion in Electronic Thesis and Dissertation Repository by an authorized administrator of Scholarship@Western. For more information, please contact wlsadmin@uwo.ca.

A STUDY OF FAUNAL CONSUMPTION AT THE GALLINAZO GROUP SITE,
NORTHERN COAST OF PERU

Monograph

by
Claire Venet-Rogers

Graduate Program in Anthropology

A thesis submitted in partial fulfillment
of the requirements for the degree of
Master of Arts

The School of Graduate and Postdoctoral Studies
The University of Western Ontario
London, Ontario, Canada

© Claire Venet-Rogers 2014

Abstract

This thesis is an investigation into consumption patterns at the Gallinazo Group archaeological site, from the Early Intermediate Period (200 B.C. to 800 A.D.), on the Peruvian north coast. Faunal samples were recovered from two different but contemporaneous contexts: a civic-ceremonial platform mound and an Architectural Compound in a residential sector. The main objectives were: 1) create a faunal database for the site; 2) assess the nature of faunal resources consumed in these two different contexts; and 3) contribute to the zooarchaeological literature on the use of consumption patterns to reconstruct aspects of ancient complex societies. For each specimen collected, the species, element, state of fusion, and length were recorded. Differences suggest that the nature of consumption activities varied in both areas of the site. Occupants were exploiting a range of ecological habitats and practiced camelid husbandry, suggesting that increased control and exploitation of their environment was connected to state-emergence.

Keywords

Peru, zooarchaeology, Gallinazo Group, Virú Valley, faunal, consumption.

Acknowledgments

A special thank you to Dr. Lisa Hodgetts, the best supervisor one could ask for: friendly, approachable, and so very patient. Thank you Dr. Jean-François Millaire, for your edits and your fine eye to detail, and for organizing a place for me to stay in Peru. Thanks to Dr. Victor F. Vásquez Sánchez and Dr. Teresa E. Rosales Tham, for letting me use their facilities, for their extensive zooarchaeological knowledge, and their wonderful cooking. Thanks to the Rosales family for letting me live, laugh, and eat among them. Thanks to my friends and peers for the great company, the stimulating conversations, and the many laughs over some Grad Club beers. Thanks to Dr. Chris Ellis, Dr. El Molto, Dr. Christine White, and Dr. Ian Colquhoun for their feedback over the course of my time as an M.A. student.

Thank you, Chelsey Armstrong, for always being there for me, for your brilliant mind, and for the many times we bonded over some "battery acid" wine. Thank you to Jose Aquino, the best tree-climbing partner one could ask for. Thank you Caleigh Farrell, you are classy, you are fiery, you are clever, and you are a great friend. Thank you, Jonathan Giles, my very first "anthropology buddy" during my undergraduate years. You've always been there for me, and you've taught me so much. I don't think you truly know just how positive an influence you have been to my personal growth. Thank you to Brian Venne, who taught me that friendship and relationship can go hand-in-hand. You've encouraged me to speak up and be confident. You were there during a very dark time in my life, never wavering in your loyalty and always supportive. Thank you to Lisa Brown and Matt McKarney, for providing me with a place to stay and keeping me out of harm's way. Thank you to Ian Puppe and Joshua Smith, for the many conversations that pushed at the boundaries of my mind and shook up my comfort zones. Thank you to the members of the Committee for Women in Anthropology. Together, we are addressing very important issues that women in our discipline are facing. Thank you Sarah Schulist, for giving me room to grow and make mistakes, and for letting me know it's OK to say 'no' sometimes and focus instead on taking care of myself. You were an instrumental part of me becoming the feminist I am today. Thank you Diana, Siobhan, and Mary from PSAC Local 610 for their support and dedication towards a cause that is dear to the hearts of many in the Committee for Women in Anthropology.

Thank you to the Animal Farm. To the guinea pigs, for keeping me on my toes and reminding me never to judge a book by its cover. You are a lot smarter than you look. Thank you to Princess Leia, I will always be in awe of your ultimate fluffiness. Thank you Liam Neeson. I dreamed of you for a long time. I always wanted a black kitty full of energy and a sharp-mind. I definitely got what I asked for...

Thank you to my parents, who have supported me through the highs and lows and who've encouraged me to pursue a career I would love (even if it meant sacrificing a bountiful salary).

Lastly, my thanks are extended to the Social Sciences and Humanities Council for their financial contribution to my research.

Table of Content

Abstract	ii
Acknowledgments.....	iii
Table of Content.....	iv
List of Tables	viii
List of Figures.....	ix
List of Appendices.....	xi
Chapter 1	1
1 Introduction	1
1.1 Recent archaeological research in the study region.....	5
1.1.1 The North Coast polities of the Early Intermediate Period.....	5
1.1.2 The Virú Society and the Gallinazo Group Site.....	9
1.1.3 The Southern Platform and Architectural Compound 2.....	11
1.1.3.1 The Southern Platform.....	12
1.1.3.2 Architectural Compound 2.....	15
1.2 Recent archaeological research in the study region.....	18
Chapter 2.....	19
2 Environmental Context, Background, and Methodology	19
2.1 Environmental Context: The Coast, River, and Deser.....	19
2.1.1 Marine and Terrestrial Resources on the Peruvian north coast.....	20
2.1.1.1 Mammals.....	20

2.1.1.2 Birds.....	21
2.1.1.3 Fish.....	21
2.1.1.4 Invertebrates.....	22
2.1.1.5 Reptiles and Amphibians.....	22
2.2 Subsistence in the Archaeological Record of the Peruvian north coast.....	23
2.3 El Niño Events.....	25
2.4 Previous Zooarchaeological Research on Patterns of Consumption.....	26
2.5 Context.....	30
2.6 Recovery.....	32
2.7 Identification.....	38
2.8 Recording.....	39
2.9 Quantification	47
2.9.1 NISP.....	47
2.9.2 MNE and MAU.....	49
2.10 Statistical Tests and Analyses.....	50
2.10.1 Pearson's Chi-Square and the G-Test.....	51
2.10.2 Spearman's Rank Correlation Coefficient.....	52
2.11 Summary	53
Chapter 3	54
3 Results	55
3.1 Relative Abundance of Main Classes in the Southern Platform and Architectural Compound 2.....	55
3.2 A Comparison of the Main Fish, Bird, and Mammalian Species from the Southern Platform and Architectural Compound 2.....	57
3.2.1 Main Fish Taxa.....	57

3.2.2	Main Bird Taxa.....	59
3.2.3	Main Mammal Taxa.....	60
3.3	Comparison of Camelid and Sea Lion Skeletal Part Representation.....	62
3.3.1	Representation of Camelid Skeletal Parts.....	62
3.3.2	Representation of Sea Lion Skeletal Parts.....	64
3.4	Age Distribution Tables for Camelids and Sea Lions	65
3.4.1	Alpaca Epiphyseal Fusion Sequence and its Application to the Camelid Specimens from the Southern Platform and Architectural Compound 2.....	67
3.4.2	Age Distribution Table for Camelids in Architectural Compound 2 and the Southern Platform.....	69
3.4.3	Age Structure Model for Analysis of Camelid Teeth Eruption and Tooth Wear Analysis.....	71
3.4.4	Age Structure of Camelid Population in the Southern Platform based on Dental Eruption and Wear.....	73
3.4.5	Epiphyseal Fusion Sequence used for Sea Lions (<i>Otaria flavescens</i>).....	75
3.4.6	Age Distribution of Sea Lions in the Southern Platform and Architectural Compound 2.....	77
3.5	Modification and Processing of Faunal Remains	80
3.5.1	Bone Fragment Measurements.....	80
3.5.2	Burnt and Unburnt Bones.....	81
3.6	Summary	83
Chapter 4	85
4	Discussion	85

4.1 Consumption Activities at the Southern Platform and Architectural Compound 2.	85
4.1.1 Contextual Evidence.....	86
4.1.2 Feasting in the Archaeological Record.....	89
4.1.3 Possible Feasting and Ritual Consumption at the Southern Platform.....	90
4.2 Placing Consumption Activities at the Gallinazo Group Site in a Broader Regional Context.....	91
4.2.1 The Mammalian Assemblage.....	91
4.2.2 Mollusc, Fish, and Bird.....	95
4.3 Camelid Exploitation.....	99
4.3.1 The Many Uses of Camelids: Meat, Transport, Wool, and Dung.....	99
4.3.2 Camelid Herding.....	102
4.4 Summary.....	106
Chapter 5.....	108
5 Conclusion.....	108
5.1 Consumption Practices.....	108
5.2 Contributions.....	111
5.3 Future Research.....	113
References Cited.....	116
Appendices.....	132
Curriculum Vitae	137

List of Tables

Table 1: Chronology of North Coastal Peru (Masur 2012; Lanning 1967: 25; Millaire 2010).....	8
Table 2: Chronology of the Virú Valley (Millaire 2012).....	8
Table 3: Total Volumes Screened in Architectural Compound 2.....	33
Table 4: Total Volumes Screened from Southern Platform.....	34
Table 5: The Number of Individual Specimens per taxa Atop the Southern Platform and in from Architectural Compound 2.....	36
Table 6: The Latin and Common names of Identified Taxa at the Gallinazo Group.....	40
Table 7: Epiphyseal Fusion Sequence for Alpaca (from Kent.....	68
Table 8: Age Distribution Table for Camelids in Architectural Compound 2 and the Southern Platform (%).....	69
Table 9: Mandible Teeth Eruption Sequence for Llamas and Alpacas (Based on Wheeler 1982).....	72
Table 10: Age Estimates of Camelids from the Southern Platform Based on Dental Eruption.....	73
Table 11: Sea Lion Epiphyseal Fusion Sequence (Based on Borella <i>et al.</i> 2013).....	75
Table 12: Age Estimates of Sea Lions from the Southern Platform and Architectural Compound 2 based on Epiphyseal Fusion.....	78

List of Figures

Figure 1: General Map of the North Coast of Peru. By Jean-François Millaire.....	1
Figure 2: Map of the Virú Valley. By Jean-François Millaire.....	2
Figure 3: Map of Huaca Gallinazo (V-59) with areas of interest. By Jean-François Millaire.....	11
Figure 4: Map of Southern Platform of Huaca Gallinazo. By Jean-François Millaire.....	12
Figure 5: Plan View of rooms A7 and A8 on Southern Platform. By Jeisen Navarro.....	14
Figure 6: Stratigraphic Cut from Room A7 on Southern Platform (north). By Jeisen Navarro.....	14
Figure 7: Map of Architectural Compound 2 at Huaca Gallinazo. By Jean-François Millaire.....	16
Figure 8: Plan View of Rooms 2 in Architectural Compound 2. By Jeisen Navarro.....	17
Figure 9: Stratigraphic Cut from Rooms 2 in Architectural Compound 2 (East). By Jeisen Navarro.....	17
Figure 10: Relative Abundance of Main Classes in the Southern Platform and Architectural Compound 2 (%NISP).....	55
Figure 11: Representation of Main Fish Taxa (%NISP).....	58
Figure 12: Representation of Main Bird Taxa (%NISP).....	59
Figure 13: Representation of Main Mammal Taxa (%NISP).....	60
Figure 14: Representation of Camelid Skeletal Parts (%MAU).....	63
Figure 15: Representation of Sea Lion Skeletal Parts (%MAU).....	65
Figure 16: Lengths of Faunal Fragments (%).....	80

Figure 17: Percentages of Burnt, Calcined, and Unburnt bones from the Southern Platform and Architectural Compound 2.....	82
--	----

List of Appendices

Appendix A: Bone Recording Zones by Element.....	131
--	-----

Chapter 1

1 Introduction

This thesis is a study of faunal remains from the Gallinazo Group archaeological site in the Virú Valley on the north coast of Peru (Figure 1). It is an investigation into patterns of consumption in the capital city of one of the region's first states and focuses on two distinct yet contemporaneous contexts from this large settlement: refuse deposits from the civic-ceremonial platform mound (Southern Platform) and a food preparation area from a nearby residential compound (Architectural Compound 2).

Figure 1: General Map of the North Coast of Peru. By Jean-François Millaire.



The main objective of this study is to create a faunal database for the Gallinazo Group site (Figure 2) and assess the nature of the faunal resources that were consumed in each context. This research will thereby contribute to the broader Virú Polity research program (led by Jean-François Millaire) in documenting life in an early city during the first millennium of the current era and in helping to understand the processes and factors involved in the development and consolidation of state-level societies in the Andean region. This study will also contribute to the growing zooarchaeological literature on the use of consumption patterns to reconstruct political, social, ideological, and economic aspects of ancient complex societies.

Figure 2: Map of the Virú Valley. By Jean-François Millaire.



Recent archaeological investigations at the Gallinazo Group have provided evidence suggesting that the site was the capital of the Virú polity and one of the earliest urban agglomerations on the Peruvian north coast (Millaire and Eastaugh 2011). The process of urbanization has been studied by archaeologists in various parts of the world and is usually characterized by the development of centralized administration, civic monuments, increased population size, craft specialization, social differentiation, and sometimes social stratification (Haviland 1970; Hassan 1978; Marcus and Flannery 1996).

Archeologically, social differentiation can be reconstructed based on burial contexts (grave location, quantity, and quality of grave goods), architecture (houses of varying size and quality) and the distribution of material culture on ancient settlements. Ongoing research in Virú documents social differentiation through analysis of ceramics, textiles, and plant remains (Millaire *et al.* 2011).

State-formation has long been a topic of interest for archaeologists working on materials from ancient complex societies, see: Bauer *et al.* 2002; Spencer *et al.* 2001; Stanish 2000; Kirch 1984; Wilson 1983. Important research foci in understanding the rise of complex societies include potential drivers such as population pressure and the rise of conflict (Boserup 1965; Wilson 1983), ecological and environmental change (Sanders *et al.* 1988) and information exchange to facilitate large technological undertaking such as irrigation systems (Wright 1977), as well as inherent social developments such as social differentiation and elite interaction (Blanton *et al.* 1996, Spencer 1993).

While state formation has been an important area of research in the Andes (Arkush *et al.* 2005; Billman 2002; Stanish 2001; Goldstein 1993; Haas 1987; Isbell 1987; Wilson 1981), the study of early statecraft in the Virú Valley is still relatively undeveloped

(Millaire 2010). Furthermore, little attention has been paid to understanding how faunal remains may contribute to a better understanding of early state development in the region. Research in the region by Millaire (2010) has contributed radiocarbon and chronological evidence which suggests that the Virú polity may have been the first functioning state in the region. During the Early Intermediate Period, the coastal valleys of the northern coast differed in their ecological habitats, resources, trade routes, etc (Millaire 2010). This thesis research, therefore, can contribute to a better understanding the resources available to the occupants of the Virú Valley, their technology, and their trade routes during a time of great social, economic, and political change.

Creating a faunal database as a baseline for comparison will ultimately allow us to tackle questions of how diet and health may have varied from one household to the next with increased social differentiation. Were certain species of foods restricted only to certain individuals? Were certain community members importing exotic species? How were administrative centers distributing foods? What foods were being traded with peoples from the highlands? Was increasing population creating pressure on the circumscribed environments of the area? Did El Niño events affect the availability of molluscs, fish, birds, and terrestrial species and therefore affect consumption activities? Because this thesis focuses on only two assemblages, it cannot reflect the full range of variability and temporal change in faunal consumption at the Gallinazo Group site. However, it will create an important baseline for comparison when additional faunal assemblages are excavated from other areas of the site, which will facilitate a better understanding of the ways in which food played into the growing social inequalities at the site and the processes that underlay the formation of this early complex society.

This Chapter opens with an overview of the recent archaeological research in the study region, along with a detailed description of the Gallinazo Group archaeological site and the two contexts from which the samples were collected.

1.1 Recent Archaeological Research in the Study Region

1.1.1. The North Coast Polities of the Early Intermediate Period

In Andean prehistory, the Early Intermediate Period (dated to ca. 200 B.C. to A.D. 800) is a key period that saw the development of urban life and state-level societies along the north coast of Peru. Rafael Larco Hoyle was the first to document the cultural developments that marked this period on the coast, defining the temporal and geographical distribution of archaeological cultures based on architecture and artifacts uncovered in the different coastal valleys (Larco Hoyle 1938). Among the key archaeological cultures that have marked the development of urbanism and early statecraft on the north coast are Salinar (known as Puerto Morin in Virú), Moche, and Virú. Table 1 is a broad chronological sequence of the major archaeological time periods of the northern Peruvian coast. The focus of this thesis will be the occupation of the Gallinazo Group site, which occurred during the Early Intermediate Period.

The Salinar culture dates to the end of the Early Horizon, spanning from 200 B.C. to 200 A.D. The Salinar period is believed to have paved the way for the development of city states in the subsequent centuries (Brennan 1980). Salinar sites range from fortified hilltop sites to agglutinated villages or dispersed households on flat lands, small

rectangular compounds that enclosed a dozen or so rooms within their walls, and low mounds featuring collapsed adobe buildings (Moseley 1992: 175). Excavations of these low mounds have revealed the presence of courts, corridors, and rooms that have been interpreted as being occupied by local elites and their retainers. It is believed that during this time period there was competition for cultivable lands and irrigation, as suggested by the increased evidence of fortified sites and defensive structures (Brennan 1982). One of the most notable Salinar-phase sites is Cerro Arena, which shows some of the earliest signs of urbanism. The site covers 2.5-sq. km, and is composed of residential buildings of varying size and quality, suggesting social stratification.

Following the demise of the Salinar culture in the Virú Valley, a polity emerged that soon developed into a fully-fledged state: the Virú polity (Millaire 2010). Table 2 is a chronological sequence of the major cultural time periods of the Virú Valley. The Puerto Morin phase, believed to have ended approximately around 200 B.C. with major societal changes and dramatic demographic growth. The Virú occupation of the valley dates to between 200 B.C. and 600 A.D (Millaire 2013).

In the neighbouring Moche Valley, early urban settlements developed (e.g. Cerro Oreja) until the emergence of a fully-fledged city, Huacas de Moche, believed to represent the capital city of the Moche realm. The Moche society also developed during the Early Intermediate Period, and is well known on the coast for its production of fine ceramic vessels decorated with impressive iconography, and for the construction of large platform mounds in several coastal valleys. Huacas de Moche features two large platform mounds that frame an urban center that features large residential compounds as well as workshops (Armas 1996; Chapdelaine 2001, 2002; Millaire 2008; van Gijsegheem 2001). The

platform mounds have been interpreted as having fulfilled civic-ceremonial roles, including public gatherings and human sacrifice (Bourget 2001; Uceda 2001; Verano 2001). Huacas de Moche have been interpreted as the center of a complex system of settlements, while also being an administrative center engaged in the organization and management of trade, defense, and irrigation (Billman 2002).

Previous archaeological investigations have attempted to determine whether the Moche state arose in a context where no earlier states had existed or whether it was one of many states to have developed at this time in the northern coast of Peru. Recent investigations by Fogel (1993) and Millaire (2010, 2011) highlight mounting evidence that suggests that Moche state society developed out of pre-existing political institutions that emerged in the Virú Valley.

With the rise of the Moche polity in the neighbouring valley, we see a shift in allegiances and a political realignment of Virú leaders with their powerful neighbours, signaling the beginning of the Huancaco period, spanning from 600-750 A.D. Last, we have the Tomaval period where we see influences from the central coast and the highlands in the Virú valley. By the end of the Tomaval period, we see the valley being integrated into the Chimor kingdom

Table 1: Chronology of North Coastal Peru (Masur 2012; Lanning 1967:25; Millaire 2010).

Time Period	Dates
Late Horizon	A.D. 1476 – 1532
Late Intermediate Period	A.D. 1000 – 1476
Middle Horizon	A.D. 800 – 1000
Early Intermediate Period	200 B.C. – A.D. 800
Early Horizon	900 – 200 B.C.
Initial Period	1800 – 900 B.C.
Cotton Preceramic	3000 – 1800 B.C.
Archaic	pre – 3000 B.C.

Table 2: Chronology of the Virú Valley (Millaire 2012)

Tomaval	c. 750 A.D.- 1150 A.D.
Huancaco	c. 600 A.D.- 750 A.D.
Virú	c. 200 B.C.- 600 A.D.
Puerto Moorin/Salinar	c. ? - 200 B.C.

The Virú polity, arising during the Early Intermediate Period, was first defined by Larco Hoyle (Larco Hoyle 1945) and was subsequently described under the label “Gallinazo” by members of the Virú Valley Project (Bennett 1950; Ford 1949; Strong and Evans 1952; Willey 1953). The term “Virú” will be used throughout this thesis following the current usage among Virú scholars (Millaire and Morlion 2009). Early work in the valley by Willey (Willey 1953) indicated that the Virú polity succeeded in establishing its control over the people and resources of the entire valley. The Virú occupation of the valley also marked the establishment of one of the earliest state-level societies in the

region and the development of the earliest urban agglomeration in the region: the Gallinazo Group.

1.1.2. The Virú Society and the Gallinazo Group Site

The Early Intermediate Period in the Virú Valley was a time of great change, marked by many social, political, and economic transformations including the creation of a unified administration across the valley, an increase in population size, an increase in the overall number of settlements across the valley, the extension of cultivated lands into previously unused areas, and the construction of a new system of irrigation canals (Millaire 2010).

The Gallinazo Group site, the capital of the Virú polity, has been the focus of archaeological investigations for many decades, beginning with the work of Larco Hoyle (1945), Bennett (1950), Strong and Evans (1952), Fogel (1993), and more recently by Millaire and his team (2009; 2010a; 2010b; 2011).

Developing around 200 B.C. (Millaire 2010), the Virú polity soon established a four-tiered settlement system that included a capital city (the Gallinazo Group), mid-sized administrative and defensive settlements, villages, and hamlets (Millaire 2010; Willey 1953). The Gallinazo Group site covers an area of approximately 600ha, and is located approximately four kilometers from the coast. The site was formed by the deposition and accumulation of materials resulting from hundreds of years of occupation (Millaire 2010). It is centered around a series of mounds, including a large central *huaca*. The word 'huaca' is a Quechua-derived term used for any place, object, or architecture that represents something that is revered. This *huaca*, called Huaca Gallinazo (V-59) (Figure

3), has a volume of 82,000 cu m (Millaire and Eastaugh 2011). This monumental centre is large and imposing, overlooking the rest of the site, and is composed of chambers, building columns, platforms, plazas, and patios (Millaire 2010). The presence of nonresidential buildings suggests that Virú leaders were accumulating wealth and were organizing labour and resources for the construction of public architecture.

Willey (1953) successfully demonstrated how the extension of agricultural fields and irrigation canals in the northern margins of the valley allowed for the rise and maintenance of such a large population. Recent analyses suggest that the site could have held a population ranging from approximately 10,000 to 14,000 people (Millaire and Eastaugh 2011). The residential structures vary in their overall size and quality, suggesting social stratification among the population. These residences range from small rooms to multi-room compounds with patios and decorated walls (Millaire and Eastaugh 2011: 291). Overall, the buildings are built in reference to one another, with civic buildings sharing a common orientation with the residential compounds and plazas (Bennett 1950). Radiocarbon dates collected from the civic building at the Huaca Gallinazo as well as from a residential sector strongly suggest that both were occupied over a long period of time, from approximately 100 B.C. to A.D. 700 (Millaire and Eastaugh 2011).

1.1.3. The Southern Platform and Architectural Compound 2

During the 2011 field season, two areas of the site were the focus of archaeological excavation: the Southern Platform, at the summit of the Huaca Gallinazo and Architectural Compound 2, part of a domestic area, as seen in Figure 3, some distance away from the platform mound.

Figure 3: Map of Huaca Gallinazo (V-59) with Areas of Interest. By Jean-François Millaire. Note: 'Archaeological Compound 2' is synonymous with Architectural Compound 2.

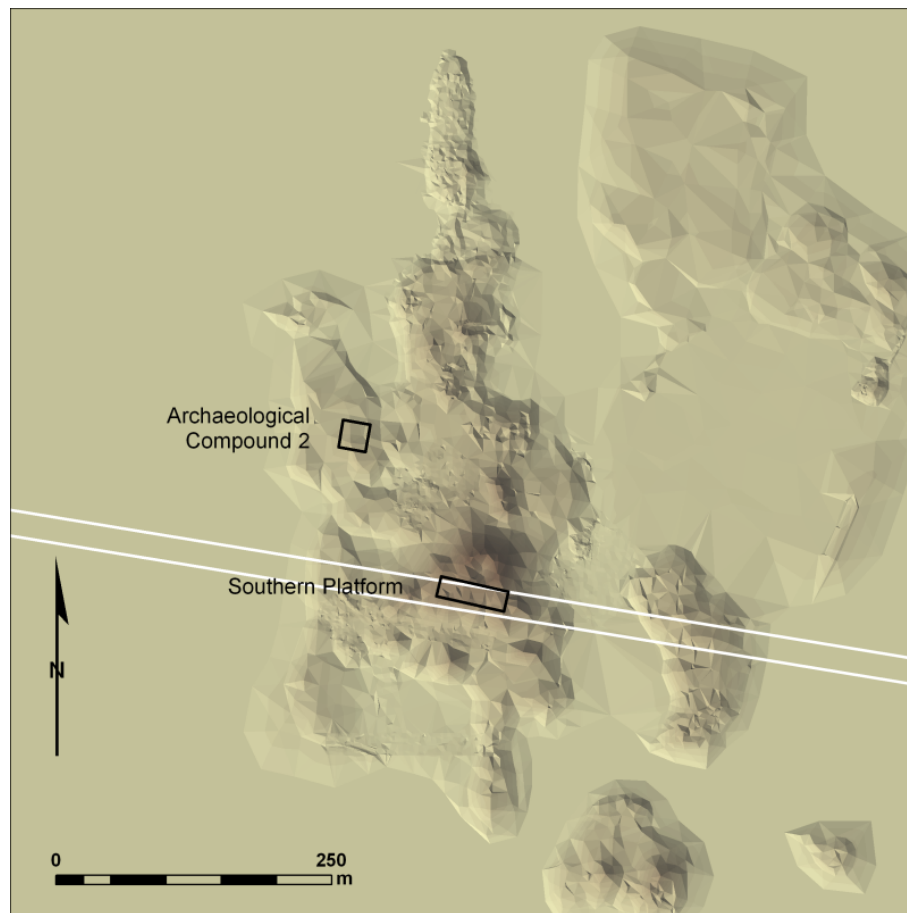

1.1.3.1. The Southern Platform (Figure 4)

Huaca Gallinazo is a large adobe platform mound that dominates the landscape. It featured massive platform at different heights (accessible through ramps) and fronts a large plaza. The building was originally decorated with sculpted friezes, wall paintings, and niched walls (Millaire and LaTorre 2011). The overall quality of the architecture contrasts sharply with buildings in the surrounding residential sectors. The Southern Platform is part of the *huaca*, and is believed to have fulfilled important elite, ceremonial, and ritual functions.

Figure 4: Map of Southern Platform (in square) of Huaca Gallinazo. By Jean-François Millaire.

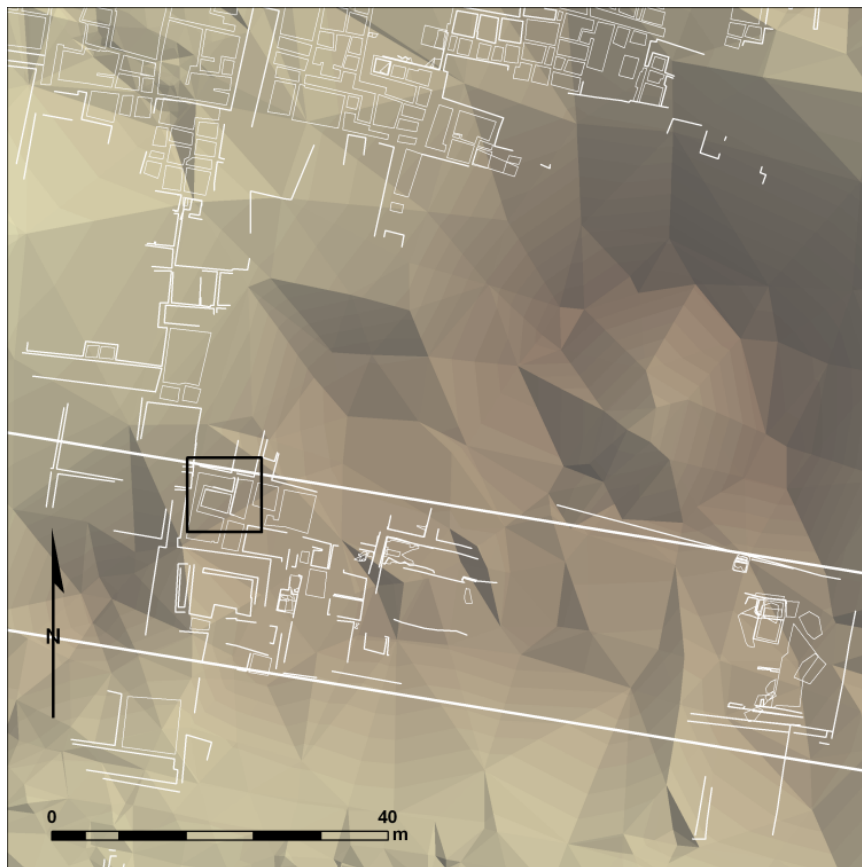

Burials have also been found on top of the *huaca*, which could suggest ritual offerings and sacrifices. Some of the burials contained grave goods such as large ceramic vessels and gourd plates. Fancy ceramics found in this sector further suggest important elite and ritual activities, although several utilitarian containers were also uncovered during the excavation process, indicating that food storage, food preparation, and food processing also took place on top of this civic-ceremonial building (Millaire and LaTorre 2011)

Rooms on the western side of the Southern Platform seem to have played a key role in food preparation in this sector. For example, rooms A-7 and A-8 (Figures 5&6) have been interpreted as kitchen areas for elite or civic use due to the recovery of substantial quantities of food remains. Associated with the food remains were adobe hearths, with organic material and blackened and fragmented ceramics.

Figure 5: Plan View of Rooms A7 and A8 on Southern Platform. By Jeisen Navarro.



Figure 6: Stratigraphic Cut from Room A7 on Southern Platform (North). By Jeisen Navarro.

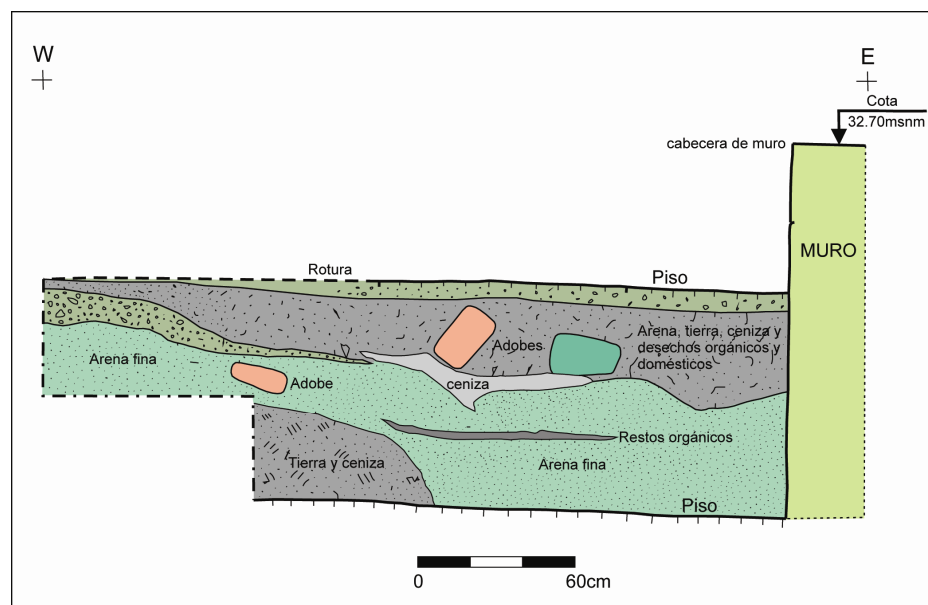

1.1.3.2. Architectural Compound 2 (Figure 7)

During the 2011 field season work was undertaken in Architectural Compound 2 under the supervision of Jordan Downey. This compound is located in the residential sector of the site, 130m northwest of the *huaca*. The compound covers an area of ca. 90m² and is composed of a number of rooms featuring living quarters, storage bins, and an open patio. Excavations were carried out inside a 10m × 10m area, in which several rooms were delimited and subsequently excavated. One room (A-2) was excavated down to the sterile subsoil, 4.3m below the present surface of the site, revealing a succession of occupations. The architecture was relatively simple, and the recovered artifacts (textiles, ceramics) were generally utilitarian in nature.

Figure 7: Map of Architectural Compound 2 (in square) at Huaca Gallinazo. By Jean-François Millaire.



Room A-2 (Figures 8 & 9) is believed to have served as a food preparation area, as evidenced by the discovery of a large storage ceramic jar, storage features, and the presence of burnt animal remains and substantial quantities of fish and shellfish remains. Burnt maize cobs and other plant remains were also recovered from this room and adjacent ones (Masur 2012). AMS dating of carbonized wood from the uppermost layer of this room suggest its terminal occupation occurred ca. A.D. 350-440, which is roughly coeval with the terminal layer in room A-8 of the Southern Platform.

Figure 8: Plan View of Room A-2 in Architectural Compound 2. By Jeisen Navarro.



Figure 9: Stratigraphic Cut from Rooms 2 in Architectural Compound 2 (East). By Jeisen Navarro.

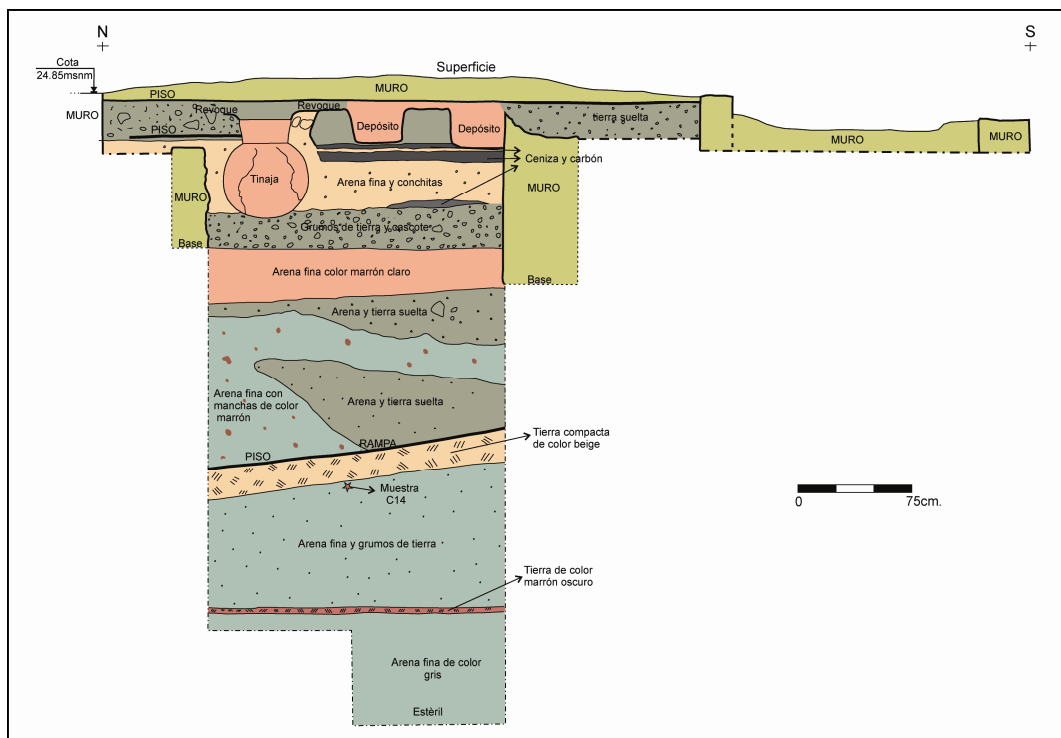

1.2 Thesis Structure

Chapter 2 of this thesis presents an overview of the environmental context and subsistence patterns in the archaeological record of the region, as well an overview of current zooarchaeological research in the Americas that has focused on the study of consumption activities. A detailed description of the laboratory methods used to gather data along with a summary of the quantitative methods and statistical tests used. Chapter 3 contains the results of my laboratory analysis, with the organization of my data according to species, skeletal element representation, modification, and age at death. Chapter 4 presents my interpretations of the results laid out in Chapter 3. Chapter 5 is a summary of the key results of the present study.

Chapter 2

2 Environmental Context, Background, and Methodology

This chapter will outline the environmental context in which the site is located, and provide an overview of the subsistence patterns in the archaeological record of the northern coast of Peru, as well as examples of zooarchaeological research that have focused on understanding and comparing different types of consumption activities. This chapter will also highlight the excavation and laboratory techniques employed in the collection and analysis of the faunal samples, and provide a summary of the resources used to identify the recovered faunal remains, and a description of the information recorded about each specimen. Finally, it describes the quantification methods employed as well as the statistical tests that were carried out to determine statistical significance.

2.1 Environmental Context: The Coast, River, and Desert

The north coast of Peru is composed of two ecological zones: a coastal zone where the waters of the Pacific Ocean meet the shoreline, and the adjacent desert and riverine system. The Pacific Ocean has a rich marine food supply, with phytoplankton serving as the first link in an extensive food web composed of small marine herbivores, fish, crustaceans, waterfowl, large sea mammals, and humans. This rich marine environment is adjacent to one of the world's driest deserts which extends along the entirety of the Peruvian coastline. This narrow strip of desert is approximately fifty kilometers wide in

most regions. The region is composed of 52 various rivers that bring the rainfall water back down to the coast, across the desert, and into the Pacific (Bawden 1996). During the Prehispanic period, canal systems were built from the point where the rivers leave their mountain courses, bringing water to agricultural lands (Bawden 1996). These river systems were used for the irrigation of agricultural lands as early as the second millennium B.C. (Bawden 1996; Billman 2002). With further aid from the construction of a complex hydraulic system in the Early Intermediate Period, people were growing a variety of different crops which included: cotton, gourd, squash, corn, peanut, beans, and manioc (Bawden 1996; Pozorski 1979; Smith 1960).

2.1.1 Marine and Terrestrial Resources on the Peruvian North Coast

The north coast of Peru is composed of diverse ecological zones, each with its unique wildlife. Below is a brief description of some of the main taxa present in these various zones organized according to mammalian, bird, fish, and invertebrate species.

2.1.1.1 Mammals

There are various terrestrial and marine mammals present on the north coast of Peru. Among the terrestrial mammals are the white-tailed deer (*Odocoileus virginianus*). Along the coastline are large sea lions (Otariidae), with the most common species being *Otaria flavescens*. Sea lions can grow to be quite large, with males weighing up to 230 and 320 kg (Nowak and Paradiso 1983: 1100). Sea lions go to the rocky promontories and sandy beaches of the coast between November and April to give birth to their pups and mate,

while the rest of the year they spend most of their time in the open sea (Schweigger 1964). They are not, however, migratory and may partly maintain their connection to the land throughout the year as well (Vaz-Ferreira 1981).

2.1.1.2 Birds

The coastline of Peru is also rich in diverse species of marine birds. Some of the most common species are: the pelican (*Pelicanus thagus*), the booby (*Sula variegata*), and the cormorant (*Phalacrocorax bougainvillii*). All three of these species are found on the coast throughout the year, nesting in their colonies along both the mainland as well as the rocky islands off the coast (Murphy 1936: 822, 841, 901). One can also come across the Humboldt Penguins (*Spheniscus humboldti*), and these breed year-round along the coast's rocky caves and feed on the fish of the Humboldt Current (Reitz 1988: 317).

2.1.1.3 Fish

Species of fish that are commonly found in the waters of the Humboldt Current are members of the herring family (Clupeidae) and anchovy (Engraulidae), both being small schooling fish attracted to the nutrient rich waters along shallow beaches (Reitz 1988: 317). Various species of the sea bass (*Paralabrax sp.*) can also be found, and these live along the rocky bottoms of the ocean where it feeds on small fish and shellfish (Schweigger 1964). Members of the Carangidae, such as the jacks and the jurels (*Trachurus spp.*) are carnivorous fish and are most abundant in the winter months (Schweigger 1964). Grunt fish (*Anisotremus spp.*, *Isacia spp.*, and *Orthopristis sp.*) are also present, congregating in dense schools on small isolated rocky ledges and reefs (Randall 1968). Drum fish (*Cynoscion spp.*, *Paralonchurus peruanus*, and *Sciaena*

deliciosa) are carnivorous fish that can be found inshore, over sandy and rocky bottoms (Fiedler 1934).

2.1.1.4 Invertebrates

Some of the most common species of molluscs present along the coastal areas of northern Peru include keyhole limpets (*Fissurella crassa*), which are found attached to rocks in lower intertidal zones of beaches, as well as the limpet (*Scurria parasitica*) which are found attached to large chitons. Other abundant species found along the shoreline of northern Peru are the Slipper shells (*Crepidula spp.*), found along intertidal shorelines, mussels (*Aulacomya ater*, *Chromomytilis*, *Perumytilis purpuratus*, and *Samimytilis algosus*) found in the lower intertidal areas along the coast, and land snails (*Scutalus spp.*) (Reitz 1988).

2.1.1.5 Reptiles and Amphibians

The desert environment of the Peruvian north coast attracts various species of reptiles, some of these such as the green iguana (*Iguana iguana*), as well as various species of the desert Tegu, (*Dicrodon spp.*). The north coast of Peru is also home to various species of toads (*Bufo spp.*), and these can be quite abundant in the regions near riverine systems and coastal marshes.

2.2 Subsistence in the Archaeological Record of the Peruvian North Coast

To better understand subsistence trends on the Peruvian north coast before and after the development of the Virú polity, detailed examples of previous studies in the region are highlighted below. Peoples living in the valleys of the Peruvian north coast would have had access to a broad range of species, as they would have been able to exploit a number of different environments. Analysis of subsistence patterns in the Moche Valley from Initial Period (1800-1400 B.C.) sites of Gramalote, as well as at the Initial Period and Early Horizon (1400-400 B.C.) settlement of Caballo Muerto by Pozorski and Pozorski (1979) focused on faunal remains. The subsistence data collected from various midden-contexts at the Gramalote site revealed that most of the animal protein consumed there came from the ocean, with a heavy emphasis on the procurement and processing of various species of clams (*Protothaca thaca*, *Eurhomalea rufa*, *Semele corrugata*, and *Gariet solida*), gastropods (*Tegula atra*, *Turbo niger*, and *Thais delessertiana*), and mussels (*Choromytilis chorus*, *Semimytilis algosus*) especially.

Among fish remains, drum fish (*Sciaena gilberti* and *Sciaena deliciosa*) dominate the assemblage, though with relatively low counts. Drum fish are relatively small compared to some of the less abundant but larger species of shark (*Mustelus sp.*) are present in the assemblage. A few bird bones were also recovered, with the most common being the cormorants (*Phalacrocorax bougainvillii*), but bones of a gull (*Laridae*) and a single penguin were also recovered. The only mammal that seems to have had dietary

significance at the site was the sea lion (*Otario byronia*), which represented about 7% of the meat diet.

At the site of Caballo Muerte, subsistence data collected from non-domestic contexts suggest there was a shift from the prior emphasis on marine species to a heavy emphasis on land mammals. The most abundant mollusk species present were large mussels (*C. chorus*), and three large species of clams (*P. thaca*, *E. rufa*, and *S. corrugata*). A large number of shells belonging to land snails (*Scutalus sp.*) were also relatively abundant. Birds and fish, however, were relatively unimportant. None of the bird remains were identifiable. Among the fish, only one bone was found and it was identified to a species of drum (*Sciaena deliciosa*). As for mammalian remains, the most abundant species was deer, which comprised 20% of the mammals, and llamas were the second most abundant species.

Evidence analyzed at the Early Intermediate Period sites of Cerro Arena by Pozorski (1979) shows a similar trend, with a shift from an emphasis on marine resources to a heavy dependence on domesticated llama (175). Prior to the Early Intermediate Period, peoples of Cerro Arena were heavily reliant on marine foods (173-175). By the Early Intermediate Period, people were eating substantial amounts of guinea pig (*Cavia porcellus*) and other terrestrial mammals such as llama.

In his analysis of urban subsistence at the site of Pampa Grande, occupied during the late Moche Period (A.D. 600-800), Shimada (1994) notes that faunal remains were largely dominated by llamas. Other domesticated species present in the assemblage include dog, guinea pig, and muscovy duck. Wild species of freshwater and marine fish, sea lion,

penguin, viscacha (*Lagidium peruanum*), and lizard were also represented. Similar trends were noted at the Moche site of Huaca de la Luna (Uceda *et al.* 2003) where the majority of mammalian remains were of sea lion and llama, with smaller quantities of dog, guinea pig, and deer. There was also the exploitation of molluscan species of saltwater clams and sea snail. Among fish remains, the most abundant were species of sardine, drum, hake, croaker, and sea catfish. The majority of bird species identified were marine birds, with the most abundant species being the gull, cormorant, booby, and pelican.

2.3 El Niño Events

The various species mentioned above are examples of animals that are relatively common the north coast of Peru. There are, however, periods in time in which environmental stability is severely affected by El Niño events. During these events, the cold Humboldt Current is replaced by a mass of warm equatorial water that can raise the normal water temperature of the coast by as much as 5°C. During El Niño events, shellfish communities shift due to changes in nutrient cycling. As a result, there is general reduction in phytoplankton biomass which ultimately leads to massive depletions of populations of anchovies and sardines (Cushing 1982: 267-295). Shellfish populations also experience severe depletion, especially species of mussels, chitons, limpets, and snail all suffer severe mortality losses. This disrupts the food web, leading to either the movement of species from these areas or to mass deaths due to starvation.

2.4 Previous Zooarchaeological Research on Patterns of Consumption

This section summarizes various zooarchaeological studies that have focused on understanding how food waste reflects different activities such as private-domestic consumption and more public events. Their observations and conclusions were useful when interpreting the faunal assemblages collected from the Gallinazo Group site, as these are examples of complex societies where foods are utilized in trade and exchange networks in ritual activities and in negotiating and signifying socioeconomic status (deFrance 2009: 106).

Just as differences in ceramic styles, burial goods, or household architecture can reflect differential access to resources, faunal remains can also suggest something of the nature of activities which took place within a household and, subsequently, the resources which these individuals had access to. Manzanilla's analysis of domestic and corporate group activities at the large urban site of Teotihuacan compared domestic subsistence, craft production, and ritual remains to shed light on the relationship between artifact and activity areas at the Oztoyahualco 15B:N6W3 multifamily compound, dated to Tlamimilolpa phase and the Late Xolalpan, the apartment compounds at the site have been interpreted as being occupied by corporate groups sharing kinship, residence, and occupation. Each apartment contained a zone for food preparation and consumption, along with sleeping quarters, storage areas, areas for refuse deposits, and patios for cult activities. The distribution of ceramic types, obsidian, polished stone, bone, antler, and shell, as well as plant micro and macro remains and faunal macrofossils show a distinct

activities taking place across the compound. The southern sector of the apartment compound was associated with sleeping quarters, with extensive evidence for food preparation and consumption, as well as refuse. The eastern sector was rich in funerary and ritual components, while the western sector was devoted to storage. Lastly, the northwestern sector was composed of a large courtyard where meeting places most likely occurred.

The southern sector of Teotihuacan had three kitchen areas where food processing and consumption occurred. Food remains found in association to grinding instruments, with storage rooms being in close proximity to the area all support this conclusion. Evidence collected from this sector also shows that butchering activities took place, as seen with faunal remains with butchery marks which were found in association to obsidian tools. In contrast, in the northern sector, where cult and ritual activities seem to have taken place, the species present there were foreign in nature, such as bear, jaguar, mother-of-pearl, and other marine shells including *Spondylus calcifer*. These were found in association to a number of human burials, suggesting that these animals probably had an important ideological or symbolic role and were used as offerings. When taking into consideration all the data collected from these various sectors, the author concluded that the families that occupied this apartment compound were most likely of the same sociopolitical status, having a relatively similar access to food and raw resources. Manzanilla's comparisons of these assemblages to determine what activities took place in the different rooms of the residential sector represents an approach that can be usefully applied in this research project. Based on the distributions of species, portions of the skeleton, and the

presence/absence of butchered remains she was able to document where foods were processed, where they were eaten, and where the remains were discarded.

Another interesting study in this context explores the faunal remains associated with public feasting at the Toqua site, a late Mississippian Dallas phase mound center in eastern Tennessee (Van Derwarker 1999). Dallas societies are characterized as being chiefdoms, in which social roles were ascribed at birth (Boyd *et al.* 1991). The study divided the site into six areas: four village areas, and two ceremonial mounds. Faunal remains were analyzed to see if patterns existed in the relative abundance of various species, the special combination of certain foodstuffs, the distribution of skeletal elements, and the distribution of different types of serving and cooking vessels. The author calculated the frequencies of various animals based on the Number of Individual Specimens, or NISP. The relative abundance of various animal remains collected from the mound contrasts starkly to the animal remains collected from village sites.

Faunal assemblages from the mound were dominated by various species of fish, while those collected from village middens were mostly dominated by mammalian remains. This contrast suggests that the activities taking place at the mounds were different from consumption behaviours at village sites, and the author further posits that fish may have been served at feasts since fish can be acquired in big enough quantities to feed people during large public events. Looking in particular at deer, the author then quantified the portions of skeletal elements at the mounds and the village sites. The assemblage from the mound shows the least amount of skeletal portions that are considered "low utility" , meaning the parts that are not particularly meaty and were therefore possibly less valued. Whole deer carcasses seem to have been brought to the ceremonial mound, which has

been interpreted as evidence that elite chiefs were bringing whole animals to large public feasts (Boyd *et al.* 1991). This research highlights how feasting events can lead to faunal assemblages that look quite different from those reflecting every-day private consumption. These observations are particularly useful in my research, since the available architectural evidence suggests that the two faunal assemblages from the Gallinazo Groups may represent examples of feasting (atop the ceremonial mound) and domestic consumption (in the residential context).

A final study worth mentioning comes from archaeological research carried out in the Valley of Oaxaca in southern Mexico associated with the development of Mesoamerican urban society and the rise of the Zapotec state. By the time of the Conquest, the Zapotec were an urban society that was socially stratified with many ranks and levels of nobility, along with commoners, serfs, and slaves (Marcus and Flannery 1996). They raised dogs and turkeys, and hunted deer, peccary, rabbits, raccoons, opossums, gophers, wood rats, quail, doves, turtles, lizards, and other small game.

The construction of large platforms topped by a series of temples, sponsored by elite families, and faunal remains associated with these structures suggest that feasts were held here so that the elite could enhance and maintain their status. Excavation of a center in Tierras Largas, dated to the Guadalupe Phase, indicates that domesticated animals were eaten during feasts. Dog remains were collected from a refuse pit in the center, and the bones show evidence of butchery marks suggesting they were consumed. Increased social stratification is also suggested by other lines of evidence, including the quality of burials and their associated grave goods and settlement patterns. Houses at the San Jose Mogote site show a gradient in prestige, ranging from small to modest to elaborate residences,

and these differences are also reflected in differential access to deer meat, mica, and marine shells (103). The development of the Zapotec into a complex state-organized society involved elite members associating themselves with ritual life, and using feasts to reinforce their status in society. Differences in status are reflected not only in the size and quality of architecture and in the quality of burials and associated burial goods, but also in differential access to certain species of animal.

The three studies presented here illustrate how faunal remains can reflect various aspects of an ancient complex society. The comparisons of faunal assemblages between different buildings can indicate the range of activities which took place across a site. Animal bone assemblages produced through ritual feasting, which often occurs in more public settings, will differ from those collected from a domestic context where the remains of every-day private meals accumulated over time. Examining the relative abundance of species in the assemblage and the representation of different portions of the skeleton can reveal these different patterns of consumption. A similar approach will therefore be employed in my own interpretation of the faunal assemblage collected at the Gallinazo Group site. Similarities or differences in the consumption activities at both locales could tell of the nature of these contexts.

2.5 Context

As discussed above, the faunal remains examined in this thesis comes from two areas of the Gallinazo Group: The Southern Platform and the Architectural Compound 2. Each

excavation area was composed of various levels of occupation, separated from one another by refuse that had been used to level out the construction of the floor above it. Because faunal samples collected from each level were small, in order to have large enough samples to compare between the two areas, the samples from the different levels of occupation at the same sector were combined together.

At Architectural Compound 2, rubble was used to build up a series of floors, with the last floor also being associated to the ultimate phase of occupation of the compound. It is likely to have been contemporaneous with the last level of occupation in Southern Platform. The materials collected from Architectural Compound 2 are associated with ash and kitchen refuse, storage bins, large earthenware jars, and rubble used to build up the various levels of occupation. As for samples collected from atop the Southern Platform, these came from refuse deposits in kitchen and food-processing areas, as well as from samples collected from earthenware jars and gourds found in association with burials.

To determine the absolute chronology of the site, twelve exploratory test pits were excavated and from these 25 radiocarbon dates were obtained. The results from this radiocarbon testing suggests that the sector at the foot of the mound, composed of architectural compounds such as Architectural Compound 2, was occupied and in full swing by 1 A.D, with radiocarbon samples dating as far back as 100 B.C. Samples collected from the Southern Platform would suggest that the civic-ceremonial mound was founded in the second century B.C. The range of radiocarbon dates collected from both sectors suggest that, though the civic-ceremonial compound was established and used first, it was being used when the compounds at the base of the mound were constructed and occupied.

2.6 Recovery

The faunal remains used in this study were collected during the 2011 summer field season. The remains were collected from the two areas mentioned above (Figure 3).

Excavated materials from most units, excluding sterile layers and layers of construction fill and rubble, were sifted through 1/8-inch screens from which faunal remains were handpicked and bagged. Not all the fill collected from the units during excavation was screened. Units that were relatively sterile and devoid of floral or faunal material did not go through the mesh, and any material of interest was hand-picked.

Approximately 10L of deposit from each unit were also screened through 1/16-inch-mesh. Faunal remains were handpicked from these meshes, with faunal remains from the same unit bagged together and tagged. The proportion of dirt sifted through the screens differed from one unit to the next. Tables 3 and 4 summarize the total volume of dirt excavated per unit, and the amount of material from each unit sieved through 1/8th inch mesh and 1/16th inch mesh. In addition, some of the analyzed material was handpicked during surface surveys. In some cases, excavation information was not recorded. Units 67, 69, 70, 71, 73, 84, 85, 90, 97, 101, and 105 had unrecorded volumes.

Table 3: Total Volumes Screened from Architectural Compound 2

Unit Number	Total Volume Excavated (L)	Total Volume Sieved through 1/8th Inch Screen (L)	Total Volume Sieved through 1/16th Inch Screen (L)
65	538	537	0
66	190	0	180
67	Not Recorded	0	0
69	Not Recorded	0	0
70	Not Recorded	0	0
71	Not Recorded	0	0
73	Not Recorded	0	0
74	66	0	64
75	26.5	26.5	0
76	15	14	0
79	134	123	10
81/82	1650	Not Recorded	Not Recorded
83	1101	1090	10

86	390	390	0
87	250	250	0
89	171	160	10
90	Not Recorded	0	0
91	331	320	10
99	81	70	10
100	71	60	10
102	90	79	10
104	41	30	10

Table 4: Total Volumes Screened from Southern Platform

Unit Number	Total Volume Excavated (L)	Total Volume Sieved through 1/8th Inch Screen (L)	Total Volume Screened through 1/16th inch Screen (L)
71	7200	7189	10
77	18	0	17

80	1904	1893	10
84	Not Recorded	0	10
85	Not Recorded	Not Recorded	Not Recorded
88	343	332	10
97	Not Recorded	Not Recorded	10
101	Not Recorded	Not Recorded	Not Recorded
103	401	390	10
105	Not recorded	0	0
106	808.6	Not Recorded	Not Recorded

Following excavation, the remains were stored in the Arqueobios Laboratory at the Universidad Nacional de Trujillo, directed by Victor Vásquez Sanchez and Theresa Rosales Tham. To help in the analysis, the number of individual specimens identified per taxa were put together into a table so as to better emphasize which species were the most abundant and in which sector (Table 5). The results were organized by sector, and include the %NISP, or the number of individual specimen in percentages. The total NISP count, including all species found on site is 3759. It is from this total that the %NISP was calculated for each species in both sectors of the site.

Table 5: The Number of Individual Specimens Per Taxa Atop the Southern Platform and from Architectural Compound 2

	Southern Platform	%NISP	Architectural Compound 2	%NISP
Fish, indeterminate	40	1.064113	154	9.5771144
<i>Anchoa sp.</i>	0	0	1	0.0621891
<i>Galeichthys peruvianus</i>	1	0.026603	4	0.2487562
<i>Sardinops sagax sagax</i>	11	0.292631	18	1.119403
<i>Trachurus symmetricus murphyi</i>	0	0	2	0.1243781
<i>Anisotremus scapularis</i>	6	0.159617	2	0.1243781
<i>Paralonchurus peruanus</i>	16	0.426667	87	5.4104478
<i>Squatina armata</i>	1	0.026603	11	0.6840796
<i>Mugil cephalus</i>	1	0.026603	0	0
<i>Sphyrna sp.</i>	1	0.026603	1	0.0621891
<i>Paralichthys sp.</i>	1	0.026603	2	0.1243781
<i>Paralichthys adpersus</i>	1	0.026603	0	0
<i>Paralabrax sp.</i>	0	0	4	0.2487562
<i>Sciaenidae, indeterminate</i>	0	0	2	0.1243781
<i>Sciaena sp.</i>	4	0.106411	11	0.6840796
<i>Sciaena deliciosa</i>	5	0.133014	22	1.3681592
<i>Sciaena starksii</i>	3	0.079808	0	0
Fish, Total:	91	2.420857	321	19.96269
Bird, indeterminate	203	5.400372	55	3.420398
Charadriiformes	1	0.026603	0	0
Procelleriidae, indeterminate	1	0.026603	0	0
<i>Calidris sp.</i>	0	0	1	0.0621891
<i>Laridae, indeterminate</i>	1	0.026603	2	0.1243781
<i>Larus sp.</i>	19	0.505454	4	0.2487562
<i>Phalacrocorax bougainvillii</i>	83	2.208034	9	0.5597015
<i>Sula sp.</i>	141	3.750998	18	1.119403
<i>Spheniscus humboldti</i>	24	0.638468	5	0.3109453
<i>Pelicanus thagus</i>	1	0.026603	2	0.1243781
Passeriiformes	3	0.079808	0	0
Icteridae, indeterminate	1	0.026603	0	0

Anatidae, indeterminate	1	0.026603	0	0
<i>Anas sp.</i>	6	0.159617	0	0
<i>Falco sparverius peruvianus</i>	0	0	5	0.3109453
<i>Gallus gallus domesticus</i>	4	0.106411	0	0
<i>Gallinula chloropus pauxila</i>	1	0.026603	0	0
Rallidae, indeterminate.	0	0	4	0.2487562
<i>Rallus sanguinolentus</i>	2	0.053206	0	0
<i>Sturnella bellicosa</i>	3	0.079808	0	0
<i>Zenaidura sp.</i>	6	0.159617	0	0
<i>Zenaida asiastica meloda</i>	3	0.079808	0	0
Bird, Total	504	13.40782	105	6.529851
<i>Bufo sp.</i>		0	2	0.1243781
Amphibian, Total:	0	0	2	0.124378
Reptile, indeterminate	7	0.18622	2	0.1243781
Dicrodon sp.	0	0	3	0.1865672
<i>Iguana iguana</i>	5	0.133014	0	0
Reptile, Total:	12	0.319234	5	0.310945
Mammal, indeterminate	1537	40.88853	536	33.333333
Artiodactyl indeterminate	165	4.389465	28	1.7412935
Camelidae, indeterminate	1	0.026603	0	0
<i>Llama sp.</i>	906	24.10215	82	5.0995025
<i>Odocoileus virginianus</i>	15	0.399042	0	0
Carnivore, indeterminate	1	0.026603	3	0.1865672
<i>Canis familiaris</i>	22	0.585262	2	0.1243781
<i>Otaria sp.</i>	130	3.458367	32	1.9900498
Rodent, indeterminate	17	0.452248	5	0.3109453
Muridae indeterminate	161	4.283054	107	6.6542289
<i>Rattus rattus</i>	25	0.66507	0	0
<i>Lagidium peruanum</i>	1	0.026603	0	0
<i>Cavia porcellus</i>	45	1.197127	7	0.4353234
<i>Homo sapiens sapiens</i>	14	0.372439	5	0.3109453
Mammal, Total:	3040	80.87257	807	50.18657
Crustacean, indeterminate	6	0.159617	0	0
Crab, indeterminate	12	0.319234	9	0.5597015
Crustacean, Total:	18	0.478851	9	0.5597015
Mollusc, indeterminate	15	0.399042	28	1.7412935
<i>Donax obesulus</i>	7	0.18622	22	1.3681592
Muricidae, indeterminate	1	0.026603	0	0

<i>Thais chocolata</i>	1	0.026603	3	0.1865672
<i>Thais haemastoma</i>	1	0.026603	9	0.5597015
<i>Sinum cymba</i>	0	0	3	0.1865672
<i>Perumytilis purpuratus</i>	1	0.026603	0	0
<i>Fissurella sp.</i>	1	0.026603	0	0
<i>Fissurella limbata</i>	0	0	2	0.1243781
<i>Fissurella latimarginata</i>	1	0.026603	0	0
<i>Fissurella maxima</i>	1	0.026603	0	0
<i>Mesodesma donacum</i>	0	0	6	0.3731343
<i>Prisogaster niger</i>	0	0	1	0.0621891
Mytilidae, indeterminate	0	0	0	0
<i>Semimytilus algosus</i>	15	0.399042	8	0.4975124
<i>Tetrapigus niger</i>	0	0	1	0.0621891
<i>Tegula atra</i>	0	0	2	0.1243781
<i>Transennella pannosa</i>	0	0	1	0.0621891
<i>Enoplochiton niger</i>	1	0.026603	0	0
<i>Scutalus sp.</i>	9	0.239425	0	0
Mollusc, Total:	54	1.436552	86	5.348259
Indeterminate	40	1.064113	282	17.537313
TOTAL	3759	100	1608	100

2.7 Identification

During the summer of 2012, I undertook the identification of the species and elements present in the faunal assemblage using the comparative collection at the Arqueobios laboratory and various osteological guides and manuals. I am grateful for the help and expertise of Dr. Vásquez and Dr. Rosales in identifying the material. Specimens were identified to the most precise taxonomic category possible. In some cases, the bones were so fragmented and weathered that they could only be identified as mammal, fish, or bird. When fragments were too small to identify to taxon and/or element, they were labeled as "indeterminate". The majority of the species present in the assemblage were present in

the Arqueobios Laboratory's reference collection. However, the skeletons in the laboratory were sometimes missing elements and in such cases I referred to a series of reference manuals (Altamirano Enciso 1983, Cohen and Serjeantson 1996, Casper 1980, Pacheco Torres et al 1979). Since Humboldt Penguins are a protected species, the Arqueobios Laboratory does not have a modern reference specimen to use for comparison. Instead, I used Natural Science Foundation funded online database *Aves 3D* (<http://aves3d.org/>), which contains 3D images of avian skeletal morphology.

2.8 Recording

Information about each specimen was recorded in a Microsoft Access database during analysis. The categories of information, and the data entered in each are listed below.

SPECIMEN NUMBER

A sequential number was assigned to each unique specimen, beginning from 1.

SITE NUMBER

All of the faunal remains were collected from the Gallinazo Group site: V-59.

SECTOR

This category identifies which sector the bone was collected from during excavation. The Southern Platform atop the platform-mound is located in Sector A, and Architectural Compound 2 is located in Sector H.

AC

This is a number identifying which Architectural Compound specimens are from; in this case either the Southern Platform or Architectural Compound 2.

ROOM

This number identifies which room in the sector the bone was collected from. Architectural Compound #2, which features rooms 1, 2, 3, 4, 5, 6, and 44. The Southern Platform includes rooms 7 and 8.

UNIT

This number identifies which unit the faunal material was recovered from. A unit is a distinct deposit.

NISP

NISP is the Number of Identified Specimens. In most cases, a single specimen was recorded in each row of the Microsoft Access. However, in cases where multiple specimens shared the same characteristics, they could be recorded together.

TAXON

This is the most precise taxonomic category to which specimen(s) can be identified. The full range of identified taxa is presented in Table 6.

Table 6: The Latin and Common Names of Identified Taxa at the Gallinazo Group Site.

Latin Name	Common Name
<i>Molluscs</i>	
Phylum <i>Mollusca</i>	Mollusc

<i>Donax obesulus</i>	Peruvian surf clam
<i>Enoplochiton niger</i>	Black chiton
<i>Fissurella</i> sp.	Key hole limpet, indeterminate
<i>Fissurella latimarginata</i>	Black limpet
<i>Fissurella limbata</i>	Purple limpet
<i>Fissurella maxima</i>	Giant keyhole limpet
<i>Mesodesma donacium</i>	Pink clam
<i>Perumytilis purpuratus</i>	Purple mussel
<i>Prisogaster niger</i>	Turban snail
<i>Scutalus</i> sp.	Land snail, indeterminate
Family <i>Mytilidae</i>	Mussel
<i>Semimytilus algosus</i>	Small mussel
<i>Sinum cymba</i>	Concave ear moon snail
<i>Tegula atra</i>	Smooth black trochid
<i>Tetrapigus niger</i>	Black sea urchin
Family <i>Muricidae</i>	Dog winkles and rock shells
<i>Thais chocolata</i>	Brown rock shell
<i>Thais haemastoma</i>	Red-mouthed rock shell
<i>Transennella pannosa</i>	Salt-water clam

Crustaceans
Subphylum *Crustacea*

Crustaceans

Order *Decapoda*

Crabs

Mammals**Class** *Mammalia*

Mammal

Artiodactyla, indet.

Unidentified artiodactyl

Odocoileus virginianus

White-tailed deer

Family *Camelidae*

Camelids

Lama sp.

Llama or Guanaco

Order *Carnivora*

Carnivores

Canis familiaris

Dog

Otaria sp.

Sea lions

Order *Rodentia*

Rodents

Family *Muridae*

Mice, Rats and Gerbils

Rattus rattus

Rat

Lagidium peruanum

Viscacha

Cavia porcellus

Guinea pig

Homo sapiens sapiens

Modern human

Reptile

Class <i>Reptilia</i>	Reptiles
<i>Iguana iguana</i>	Green iguana
<i>Dicrodon sp.</i>	Desert tegus
<i>Amphibian</i>	
<i>Bufo sp.</i>	Toad
<i>Bird</i>	
Class <i>Aves</i>	Birds
Order <i>Charadriiformes</i>	Waders, Gulls and Auks
Family <i>Procelleriidae</i>	Petrels, Prions and Shearwaters
<i>Calidris sp.</i>	Typical waders
Family <i>Laridae</i>	Gulls
<i>Larus sp.</i>	Gull
<i>Phalacrocorax bougainvillii</i>	Guanay cormorant
<i>Sula sp.</i>	Booby
<i>Spheniscus humboldti</i>	Humboldt penguin
<i>Pelicanus thagus</i>	Peruvian pelican
Order <i>Passeriformes</i>	Song birds
<i>Icteridae</i> , indet.	Colourful song birds
Family <i>Anatidae</i> , indet.	Ducks, geese, and swans

<i>Anas sp.</i>	Duck
<i>Falco sparverius peruvianus</i>	Small peruvian falcon
<i>Gallus gallus domesticus</i>	Chicken
<i>Gallinula chloropus pauilla</i>	Common moorhen
Family Rallidae	Rails
<i>Rallus sanguinolentus</i>	Plumbeous rail
<i>Sturnella bellicosa</i>	Peruvian meadow lark
<i>Zenaidura sp.</i>	Mourning dove
<i>Zenaidura asiatica meloda</i>	White-winged dove
Fish	
Class Pisces	Fish
<i>Anchoa sp.</i>	Anchovy
<i>Galeichthys peruvianus</i>	Peruvian sea catfish
<i>Sardinops sagax sagax</i>	South American pilchard
<i>Trachurus symmetricus murphyi</i>	Pacific jack mackerel
<i>Anisotremus scapularis</i>	Peruvian grunt
<i>Paralonchurus peruanus</i>	Peruvian banded croaker
<i>Squatina armata</i>	Chilean angelshark

<i>Mugil cephalus</i>	Flathead mullet
<i>Sphyrna sp.</i>	Hammerhead shark
<i>Paralichthys adpersus</i>	Fine flounder
<i>Paralabrax sp.</i>	Bass
Family <i>Sciaenidae</i> , indet.	Drums and croakers
<i>Sciaena sp.</i>	Drum
<i>Sciaena deliciosa</i>	Lorne drum
<i>Sciaena starski</i>	Check

ELEMENT

This category records the skeletal element, for example humerus or femur.

SIDE

For elements that are paired, this category records whether they are from the right or left side of the body, or indicates that side cannot be determined.

ZONES (1-10 and Unzoned Fragments)

Zones (Appendix A) record which portion of an element is represented. Each element is divided into a series of non-overlapping zones characterized by certain morphological features. See Appendix A for diagrams of zones for each element. A zone is recorded only if 50% or more of that zone is represented. Recording zones in this manner facilitates the calculation of minimum numbers of elements (MNE) for each taxon.

FUSION

A two letter code is used to indicate the state of fusion. The first letter indicates the fusion state of the proximal or anterior epiphysis. The second letter indicates the state of fusion of the distal or posterior epiphysis. The following letter codes are used:

U- unfused shaft and epiphysis

S- unfused shaft

E- unfused epiphysis

G - fusing (fusion line is still visible)

F- fused

B - baby (unfused shaft, plus size and texture of bone indicate foetal/neonatal bone)

N- unknown

For example, a humerus coded NF indicates that the fusion of the proximal end could not be determined (likely because that end of the bone was missing) and the distal end was fused.

LENGTH (mm)

This numeric value records the maximum length of the specimen, measured to the nearest millimetre.

MODIFICATION

This category notes any human or natural taphonomic markers on each specimen. The different types of modification are:

Pathology (abnormal bone development)

Cutmarks (fine marks)

Butchery marks (large deep marks)

Burnt black

Calcined (burnt white/bluish-white)

Root etching

Carnivore gnawing

Digestive corrosion

Rodent gnawing

Perforation

Weathering

2.9 Quantification

2.9.1 NISP

Several techniques were employed to describe the make-up of the assemblage. The first of these is the number of identified specimens (NISP), which is a count of the number of specimens identified for each taxonomic category. Paradoxically, this can also include a count of the number of specimens that could not be identified and were classed as “indeterminate”. Minimum Number of Individuals (MNI), is another popular

quantification technique in zooarchaeology. Rather than counting all specimens for each taxon, it determines whether elements could belong to the same individual and provides a minimum count of individuals for each taxon. For example, if white-tailed deer remains from a site included 4 right humeri, 2 left humeri, one left femur, and two ribs, the MNI would be 4, based on the most frequently represented discrete element, the right humerus. Both of these quantification methods have advantages and disadvantages.

Perhaps the greatest strength of NISP is that it is very straight-forward to calculate. It is also calculated in the same manner by all investigators, making it particularly useful for comparative analyses that synthesize the work of multiple zooarchaeologists. It does, however, have its short-comings. NISP-based species ratios do not take into account the possibility that more than one fragment in the assemblage could have come from the same individual (Ringrose 1993). Therefore, certain species whose bones may be heavily fragmented may be over-represented. NISP also tends to give larger values for taxa that tend to reach sites whole than for those that are generally butchered before transportation. While MNI removes the risk of counting any individual animal more than once, it tends to inflate the importance of rare taxa (where MNI can be very close to the NISP value) relative to common taxa (where the MNI value is often much lower than the NISP value) (Grayson 1984). Secondly, MNI counts of various species do not necessarily correlate directly with their economic importance. Different animals provide different quantities of meat, and as propositioned by Davis (1987) argues, even if an archaeological site yields more rabbit bones than cow bones, it is not fair to assume that rabbits were more economically important than cows, because they have a much smaller meat yield.

The MNI method has also been heavily critiqued by Ringrose (1993) and Grayson (1979) for not being particularly good at dealing with elements with indeterminate sides, or elements, such as lumbar vertebra, that occur multiple times in a single skeleton. Furthermore, archaeologists are not consistent in their methods of calculating MNI, and are not always explicit about how they have calculated it. This variability makes it difficult to compare MNI values between studies (Ringrose 1993). Grayson's (1979) principle objection to this method has to do with the issue of aggregation. MNI-based species ratios will differ depending on whether MNI is calculated for the entire site or for specific features or sectors. Grayson (1979) also demonstrates that NISP and MNI are theoretically and statistically linked, so most short-comings suffered by NISP are shared by MNI.

In light of these critiques of MNI-based approaches, I used NISP to evaluate the relative abundance of taxa, treating it as an ordinal measure rather than an absolute one. When looking at species representation, fragment-lengths, state of fusion, and burnt versus unburnt bone, the number of specimens were counted and then these were converted to a percentage of the total NISP to make it easier to compare relative abundance from different contexts.

2.9.2 MNE and MAU

MNE, or minimum number of elements, and MAU, or minimum animal units, are quantitative measures used to examine butchery and transport for large-bodied taxa (Binford 1978). MNE can address, for example, whether carcasses were brought whole

back to the site or whether they were butchered and processed before coming into the site. MNE is the minimum number of each element that could account for the specimens from a given taxon. MNE eliminates the possibility of counting any individual element more than once. In this thesis, I calculate MNE values by counting the most frequent zones of each skeletal element for any given species.

Because MNE over-represents skeletal elements that are present in larger numbers in an individual animal (e.g. ribs) relative to those that are present in smaller numbers (e.g. atlas vertebrae), MNE values are converted to MAU values (Minimum Animal Units). MAU accounts for the differing frequencies of different skeletal elements in any given species by dividing MNE values by the number of that element in one complete individual. It therefore allows a direct comparison between MAU values for that species from any given archaeological context. When comparing MAU values for a species between different archaeological contexts (e.g. sites or areas within sites), the values can be normed to %MAU to facilitate comparisons. %MAU is calculated by dividing each MAU value by the greatest MAU value in the assemblage, and multiplying by 100.

2.10 Statistical Tests and Analyses

Pearson's Chi-Square and the G-test were used to determine whether statistically significant differences exist between the two excavation areas for taxonomic abundance, fragment size distributions, and other categories recorded using NISP values. Two levels of statistical significance, or p-values, were used during testing: 0.05 and 0.1. These levels of significance indicate that there is a 5% or 10% chance respectively that, assuming the null hypothesis is true, the observation could have occurred by chance.

Statistical significance levels of 0.05 and 0.1 are widely used in the social sciences. While a significance level of 0.05 is more conservative and reduces the risk of falsely rejecting the null hypothesis for larger samples, small samples will produce higher p-values, and a significance level of 0.1 is often more appropriate for archaeological assemblages which tend to be smaller. When interpreting the results of my analyses, the conventional "cut-off" point for a p-value is 0.05, though for particularly small samples I use 0.1. Anything below these cutoff points is considered a very low probability, while anything above it is considered a reasonable probability. Spearman's Rank Order Correlation Coefficient was used to evaluate the strength of the relationship between the relative abundances (based on MAU) of camelid and sea lion skeletal elements in the two excavation areas.

2.10.1 Pearson's Chi-Square and the G-test

The Pearson's Chi-Square test was used in the analysis of zooarchaeological data due to its ability to test whether the frequency distribution of the observed faunal remains across the archaeological site support a null hypothesis. A null hypothesis would suggest that the patterns we see in the distribution of faunal remains across the site were simply due to chance events. It would mean there is no relationship between the two variables being tested: frequency of certain taxa according to their location. The Pearson's Chi-Square test is called the "goodness-of-fit" statistical test since it measures how well the observed distribution of data fits the distribution that is expected if the variables are independent of

one another. This test is designed to analyze categorical data, data that have been counted and divided into categories.

There are certain inherent assumptions within this approach, however. For example, this test assumes that the sample data is a random sampling from a fixed distribution or population where each member of the population has an equal probability of selection. A second issue with this approach deals with sample size. The smaller the sample size, the more inaccurate the result will be. To overcome this issue, I used the G-test, a non-parametric test, when samples were smaller than 5. Like with Pearson's Chi-Square test, this method is also used to determine statistical significance, and can be used on large or small sample sizes. As with Pearson's Test, it is also used for categorical data.

2.10.2 Spearman's Rank Correlation Coefficient

Spearman's Rank Correlation Coefficient (Spearman's rho) was used to determine the strength of the correlation between relative abundances of skeletal elements for both camelids and sea lions between the ceremonial and residential compound. As a non-parametric test of statistical dependence between two variables, it does not assume that the data are normally distributed. Spearman's rho values will always fall between -1 and +1. Negative values indicate a negative correlation between the two variables and positive values a positive correlation. Values closer to one indicate a strong positive correlation between the values (with 1 representing a perfect correlation) while values closer to zero indicate only a weak relationship between the two values. A value in the negatives suggests a strong negative correlation. P values associated with Spearman's rho

indicate the likelihood of obtaining the observed rho value for a sample of that size drawn from a population where there is no correlation between the two variables.

2.11 Summary

This chapter provided a brief description of the recovery techniques employed during excavation, as well as the identification and recording methods used in the faunal analysis. It also described the quantitative and statistical techniques used to examine the relative abundance of species and the representation of skeletal portions of the main large-bodied taxa.

Chapter 3

3 Results

This chapter presents the recovery method and results of the faunal analysis at the Gallinazo Group site. It examines taxonomic abundance in the Architectural Compound 2 and on the Southern Platform in order to document potential differences in faunal consumption between these contexts. It also presents bone fragment size distributions and ratios of burnt to unburnt bone in order to examine butchery and processing practices in both areas of the site. It then focusses on exploitation of the two most important taxa, camelids (*Lama sp.*) and sea lions (*Otaria sp.*), examining the distribution of skeletal elements to better understand how they were butchered, transported, and consumed. It also uses epiphyseal fusion data to determine the age structure of the exploited populations, which will shed light on the management practices for camelids and hunting practices for sea lions. In the case of camelids, tooth eruption and wear data also contribute to the reconstruction of population age structure. Several statistical tests are used to determine whether statistically significant differences exist in faunal exploitation between the two excavation areas.

3.1 Relative Abundance of Main Classes in the Southern Platform and Architectural Compound 2

The relative abundance of the main classes of animals represented in both the Southern Platform and Architectural Compound 2 is presented as percentages of the total NISP for that excavation in Figure 10.

Figure 10: Relative Abundance of Main Classes in the Southern Platform and Architectural Compound 2 (%NISP)

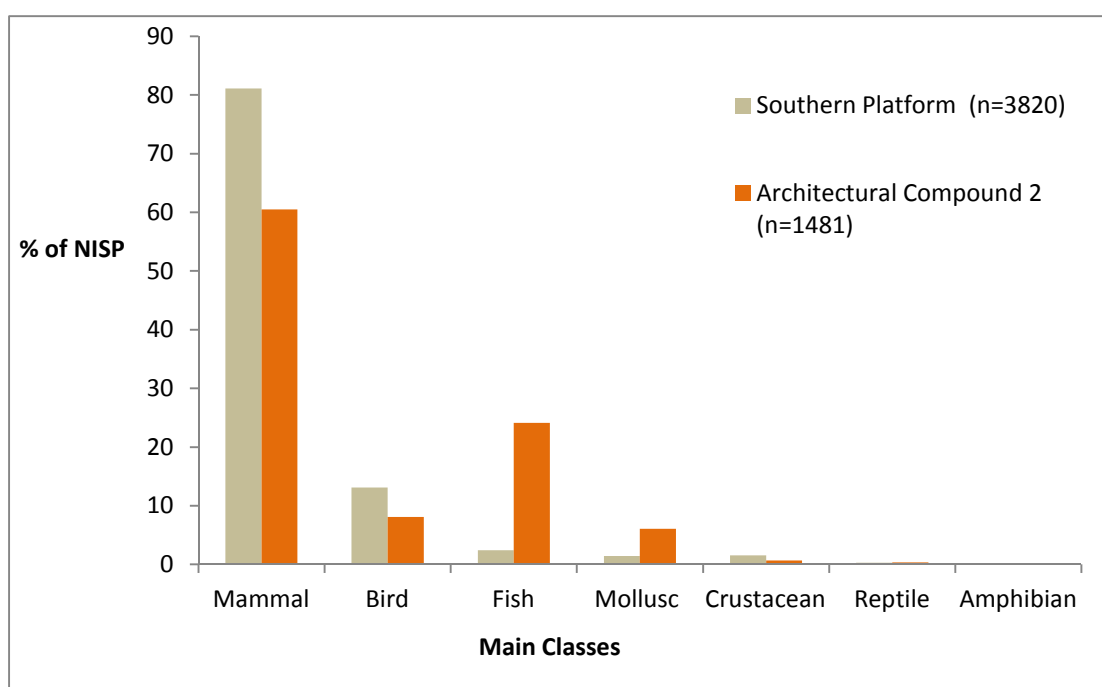

Mammals are clearly the most abundant class in both sectors. In the ceremonial context, birds are the second most prevalent, followed by fish and molluscs. In the residential context, however, fish are the second most abundant class, followed by birds and molluscs. Amphibians, reptiles and crustaceans play a relatively minor role in both sectors. Pearson's Chi-Square statistical test indicates a statistically significant difference between the abundance of mammals, fish, birds, and molluscs in the two assemblages (χ^2

(3, 5243) = 0.000 $p < .001$). Fish, and to a lesser degree bird, may be somewhat under-represented relative to mammal remains because they do not preserve as well (cf. Szpak 2011). However, the arid setting of the Gallinazo Group site promotes excellent organic preservation, so the differences in class abundance visible in Figure 10 almost certainly reflect differences in the proportions in which they were originally deposited on the site, rather than simply differences in preservation.

Mammals, then, seem to have been an important component of meals served in both areas of the site. This emphasis on terrestrial resources, especially camelids, is seen on other contemporaneous sites on the Peruvian north coast. This emphasis began in the Early Horizon, where most sites prior to this period in time show a heavy emphasis on marine resources (Pozorski 1979). The differences between the amounts of bird and fish remains in the two areas may be associated with differences in consumption activities which took place in these two different contexts, perhaps related to the civic nature of the Southern Platform and the private consumption in the Architectural Compound 2. The few crustacean remains which were identified were usually small crabs, suggesting that these were consumed opportunistically. The low amounts of amphibian and reptilian remains could suggest that these were also only eaten occasionally, and may not have been a preferred source of food, possibly because their low meat yield made them undesirable or for other cultural preferences.

3.2 A Comparison of the Main Fish, Bird, and Mammalian Species from the Southern Platform and Architectural Compound 2

Fish, mammals and birds account for the vast majority of faunal remains at the Gallinazo Group site, accounting for 97.43% percent of the identified specimens on the platform and 92.63% percent of the identified specimens in Architectural Compound 2. The relative abundance of the main fish, bird and mammal species are similar for both areas, with a few notable differences in their absolute abundance.

3.2.1 Main Fish Taxa

The most abundant species of fish present in both assemblages were sardines, the Peruvian banded croaker, and various species of drum fish (Figure 11). In both contexts, Peruvian banded croaker dominates the assemblage. At the Southern Platform, sardines are the second most abundant species in the assemblage, followed by various species of drum fish. In Architectural Compound 2, *Sciaena deliciosa*, the Lorna Drum is the second most abundant, closely followed by sardines.

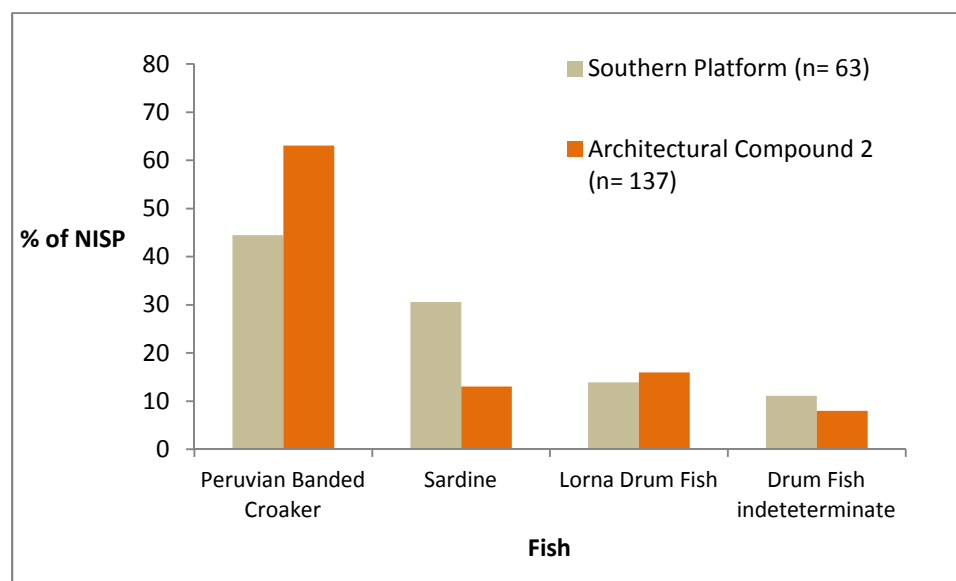
Figure 11: Representation of Main Fish Taxa (%NISP)

Relatively small samples of fish remains were recovered from both areas. The low frequency of certain species in the assemblage made it so that any statistical testing would yield results that are uncertain. Both the Pearson's Chi-Square test and a G-test were done. The results for the G-test were: $\chi^2 = (3, 200) = 0.591$; $p > 0.01$. The likelihood ratio yielded by the G-test suggests that the result is not statistically significant. When using Pearson's Chi-Square test, the p -value of 0.619, also an insignificant result. Though the G-test suggests that these results are statistically insignificant, there are a few things that can be discussed further in regards to fish consumption at the Gallinazo Group site. These four species are marine species of fish, suggesting that coastal fishing was emphasized. These four species occupy different depth levels in the ocean, which can tell us something of the technologies used by the people who consumed them. This will be discussed in more detail in Chapter 4.

3.2.2 Main Bird Taxa

The main bird taxa present in both sectors were gulls, boobies, cormorants, and Humboldt Penguins, however the relative abundance of these species varies between sectors (Figure 12).

Figure 12: Representation of Main Bird Taxa (%NISP)

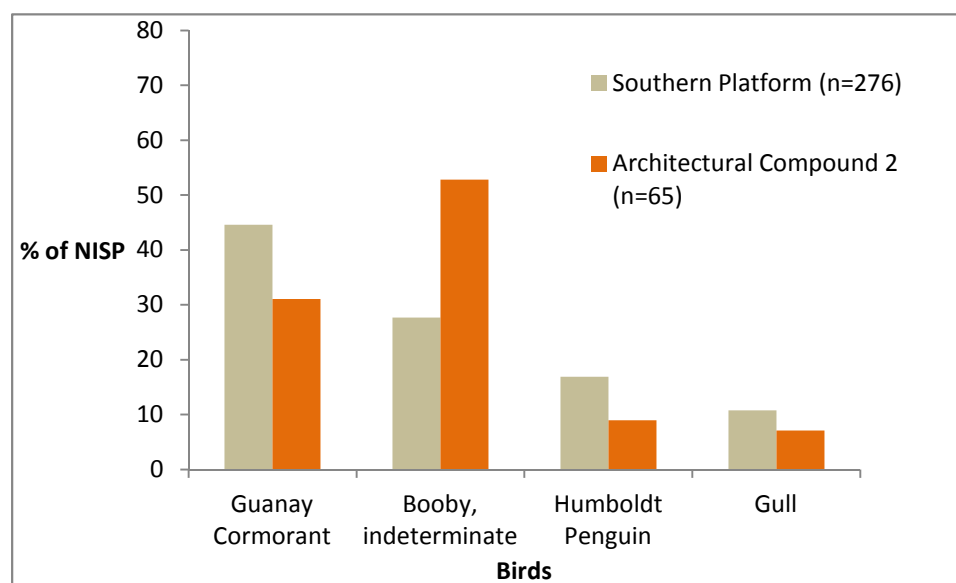

On the Southern Platform, cormorants are the best represented bird taxon followed by boobies, penguins, and gulls. In contrast, in Architectural Compound 2 boobies dominate the assemblage, followed by cormorants, penguins, and gulls. There is a significant difference in the representation of the four main bird taxa between the two assemblages ($\chi^2(3, 341) = p=0.006$; $p<0.01$). Given the proximity of the site to the coast, it is not surprising that the four most abundant species of bird in both areas are marine birds. The Humboldt Penguin are commonly found in caves or rocky outcrops along the coastline or on islands, hunting these would have been tricky, though it is possible that some of the penguin remains are of individuals who got tangled in fishing nets. Many of the bird

bones exhibited evidence of processing such as cut-marks or having been cooked. The more heavily processed remains were of those belonging to the Humboldt Penguins, suggesting that these were hunted or collected for consumption. Smaller species of bird, such as the booby and gull, were not only killed for their meat but their bones were also used in the manufacture of beads and ornaments as seen in bird fragments that had been polished and their edges smoothed, resembling a tubular bead.

3.2.3 Main Mammal Taxa

The relative abundance of the main mammalian taxa was consistent for both assemblages, with camelid the dominant mammal in both cases, followed by sea lion, guinea pig and dog (Figure 13). However, camelids account for a larger proportion of the remains in the ceremonial area, while sea lions comprise a larger proportion of the residential assemblage.

Figure 13: Representation of Main Mammal Taxa (%NISP)

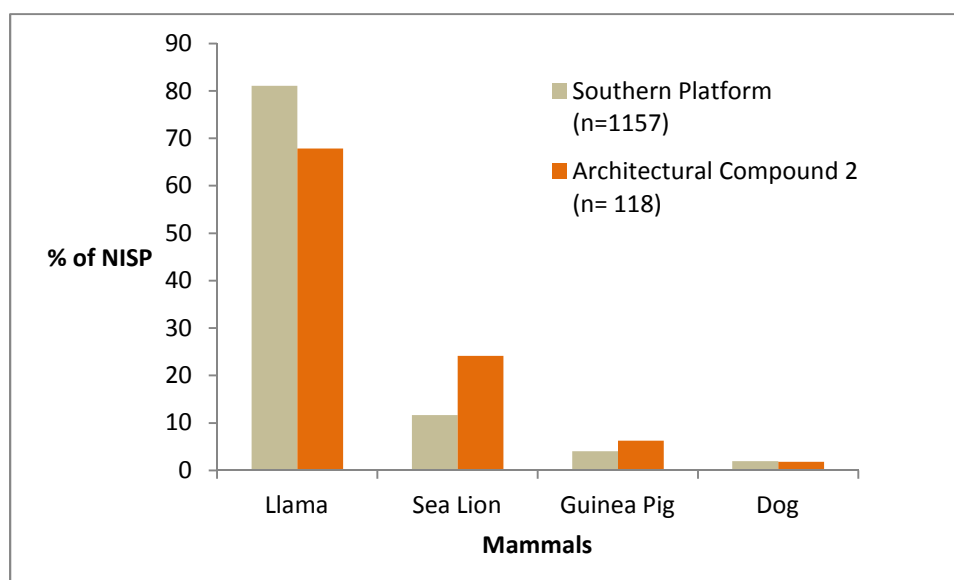

The two assemblages had markedly different sample sizes. NISP for the main mammalian taxa was 1118 in Architectural Compound 2, however due to heavy processing and fragmentation of the faunal material they account for an NISP of only 118 in the residential sector. Though the sample size is large, added precautions were undertaken and a G-test was performed to determine statistical significance due to certain species in the assemblage falling under 5 counts. Therefore, both the Chi-Square and G-test results will be reported. For the Pearson's Chi-Square test, a result p -value of 0.137 at a significance level of 0.05 ($\chi^2 (3, 1275) = p=0.137$; $p>0.01$). As for the G-test, the p -value was 0.164 ($\chi^2 (3, 1275) = 0.164$; $p>0.01$).

It is obvious that camelids dominate the assemblage collected from both excavation areas, suggesting that terrestrial mammal resources were particularly important in the diets of individuals living at the site. The emphasis on camelids as a source of meat follows patterns seen elsewhere on the Peruvian north coast, such as in the Moche Valley (Pozorski 1979). Marine resources, such as the sea lion, also seem to have been an important source of meat and are in abundance in both areas of the site. Dog and guinea pig also occur, though in much lower frequencies than sea lions and camelids. Though deer data was not presented on the graph, and are relatively infrequent compared to these four other species, they are worth mentioning because of their prior importance in the diet of peoples of the Peruvian north coast prior to the Early Intermediate Period (Pozorski 1979). No deer were noted in Architectural Compound 2, though 15 deer elements were identified on the Southern Platform, suggesting that these may have been consumed in certain contexts.

3.3 Comparison of Camelid and Sea Lion Skeletal Part Representation

Zooarchaeologists examine skeletal part representation of large-bodied taxa to understand how these animals were butchered, transported and processed by past groups. Here, I examine the representation of different skeletal portions for the two main large-bodied taxa exploited at the Gallinazo Group site: camelids and sea lions skeletons. Spearman's rank correlation coefficient is used to compare the distributions of these skeletal parts between the platform and the residential compound.

3.3.1 Representation of Camelid Skeletal Parts

Individual skeletal elements were grouped in broader anatomical categories: head (cranium and mandible), neck (atlas, axis, and cervical vertebra), axial (thoracic and lumbar vertebra, sacrum, pelvis, ribs, and sternum), upper front leg (scapula and humerus), upper hind leg (femur), lower front leg (radius, ulna, and metacarpus), lower hind leg (tibia, fibula, patella, and metatarsus), and feet (phalanges).

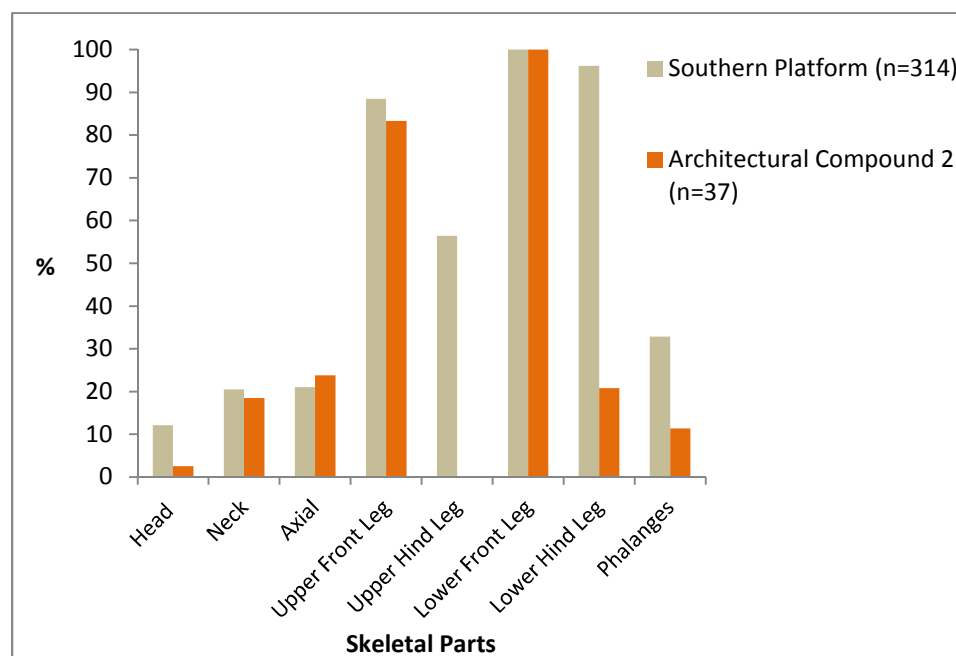
Figure 14: Representation of Camelid Skeletal Parts (%MAU)

The NISP counts for identifiable skeletal elements for the camelid bones in Architectural Compound 2 is 37 and in 314 on the Southern Platform (Figure 14). The smaller assemblage from the architectural compound can be partly attributed to the fact that many of the mammal bones in this assemblage were not identifiable past their class. The most prevalent camelid skeletal portions on the Southern Platform are the lower hind and lower front leg elements, and to a lesser degree the upper hind leg. In Architectural Compound 2, the lower front legs and upper front legs dominate, while lower hind legs are poorly represented and upper hind legs are absent. Spearman's correlation coefficient suggests only a very weak positive correlation between the skeletal part distributions in the two sectors ($r_s = 0.4819$, $p = 0.214$).

The camelid skeletal elements that were the most abundant in the assemblage are associated with the meatier portions of the animal, as one would expect if camelids were

kept for consumption. However, the presence of other elements of the skeleton such as the skull and phalanges suggests a number of things too, such as domestication and the use of elements as tools or possibly ornaments, or perhaps for their symbolic function.

3.3.2 Representation of Sea Lion Skeletal Parts

Again, the sample from Architectural Compound 2 was small because the high degree of fragmentation made it difficult to identify many mammalian elements beyond class. The total NISP count for sea lion elements on the Southern Platform was 314 and 37 in Architectural Compound 2 (Figure 15). For both assemblages, the samples are small and may be more influenced by chance than by real trends in the data. The Southern Platform is dominated by lower forelimbs, with upper forelimbs, lower hindlimbs, and axial elements being relatively abundant as well. The Architectural Compound 2 is dominated by upper forelimbs, lower forelimbs, and lower hindlimbs, while upper hindlimbs are absent. Spearman's rho suggests that there is no meaningful correlation between skeletal part representation in the two areas ($r_s = 0.024$, $p = 0.074$)

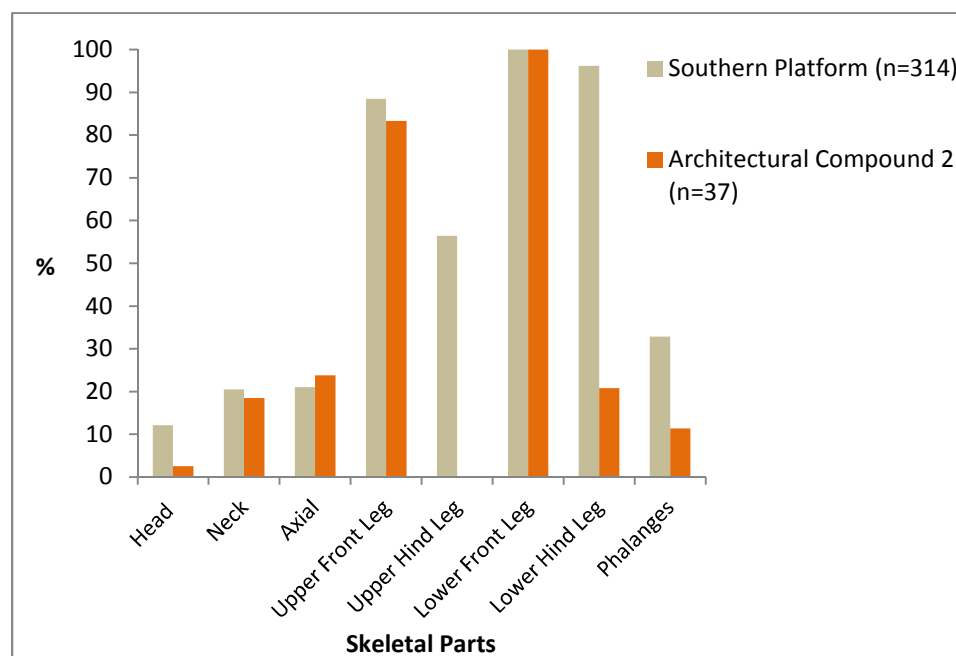
Figure 15: Representation of Sea Lion Skeletal Parts (%MAU)

Once again, the most abundant portions of the skeleton are those associated with the meatier parts of the skeleton which, along with evidence of burning and cut-marks, suggest that these were the preferred elements for consumption. The presence of other less-meaty portions of the skeleton, such as the phalanges and the head, implies that individuals either transported whole carcasses to the site, or these were processed to make transportation to the site easier. It is also possible that the less meatier portions of the skeleton held a certain value for occupants of the site, maybe ritualistic or symbolic.

3.4 Age Distribution Tables for Camelids and Sea Lions

Zooarchaeologists also examine the age structure of animal populations to document herd management practices for domesticated animals and human hunting strategies for wild

species. Several techniques can be used to estimate the age of individual animals based on their skeletal remains. The most common include examining the state of epiphyseal fusion of the long-bones, dental eruption and wear (Silver 1969; Payne 1973), and recording incremental growth structures in tooth thin-sections (Burke *et al.* 1993; Moffitt 1998). Thin sections are time-consuming to produce, so because of the time constraints on Masters research, this thesis employs the first two techniques. The state of epiphyseal fusion of the long bones can be used to estimate the age of mammals for which the fusion sequence is known. In juvenile individuals, long bone epiphyses are separated from the diaphysis by cartilagenous plates. As the individual grows, these cartilagenous plates ossify and the articular ends begin to fuse to the diaphysis, at which state longitudinal growth of longbones ceases. The age at which each epiphysis fuses is fairly constant within a given species, allowing an age estimate based on the state of fusion. This method is obviously most useful for determining the age of young individuals, since once an individual's bones have all fused, it can only provide a minimum age estimate. Therefore, this method is best used in conjunction with the second method: dental eruption and wear.

Mammals grow two sets of teeth over the course of their lifetime: deciduous teeth (i.e. milk teeth) and permanent teeth. The growth and eruption of these teeth, as with long-bone fusion, occurs according to a set sequence and if that sequence is known then it can be used to determine the age of the individual at death. As with long-bone fusion, once all the permanent teeth have erupted, this approach can only provide a minimum age estimate. Dental wear can then be used to estimate the age of an individual. Published sequences of dental wear exist for many species and can be used to estimate age at death.

These sequences must be used with caution since dental wear is affected not only by age but by diet and environmental conditions (Monks 1981).

3.4.1 Alpaca Epiphyseal Fusion Sequence and its Application to the Camelid Specimens from Architectural Compound 2 and the Southern Platform

Table 7 presents Kent's (1982) fusion sequence for alpacas, used here to estimate the age of the camelid remains from the Gallinazo Group site. The precise timing of epiphyseal closure varies between species, and to a lesser degree between different populations of the same species and between wild and domesticated forms (Guillermo L. Mengoni 1988). Because all four South American camelid species are closely related, I will apply Kent's age of fusion estimates for guanaco/alpaca to all camelids, which may introduce some inaccuracies. However, because epiphyseal fusion data from disarticulated elements (rather than complete skeletons) can only provide very coarse age estimates, small variations in the timing of fusion between species are unlikely to influence the results.

Kent's (1982) fusion sequence for alpaca is based on a total of 61 individuals of known ages from Tierra del Fuego, most of them between the ages of 10 days and 16 years. The age classes indicate the typical range in months at which the element becomes completely fused.

Table 7: Epiphyseal Fusion Sequence for Alpaca from Kent 1982

Age Class (Months)	Skeletal Age Group	Elements (completely fused)
0-12	1	Pelvis, ischium to pubis
12-24	2	Pelvis, (ilium to ischium) Pelvis (ilium to pelvis) Scapula (coracoids) Humerus, distal Humerus, distal epicondyles Phalange, proximal Tibia, distal
24-36	3	Humerus, proximal Metapodials, distal Calcaneus Radius-Ulna, distal* Tibia, proximal (tibia and diaphysis) Femur, distal
36-48	4	Femur, proximal (head)
48-60	5	Radius-Ulna, proximal (olecranon) Tibia, proximal (epiphysis to diaphysis)
60+	6	

3.4.2 Age Distribution Table for Camelids in Architectural Compound 2 and the Southern Platform

Table 8: Age Distribution table for Camelids in Architectural Compound 2 and the Southern Platform (%)

Skeletal Age Group	Epiphyses	Southern Platform			Architectural Compound 2		
		Number Fused	Number Unfused	%Fused	Number Fused	Number Unfused	%Fused
2	Scapula (coracoids)	4	1		1	1	
	Humerus, distal	9	0		0	0	
	Phalange, proximal	50	3		0	0	
	Tibia, distal	8	0		0	0	
	Total	71	4	93.42	1	1	50%
3	Humerus, proximal	1	0		0	0	
	Metapodials, distal	6	1		1	0	
	Calcaneus	9	0		0	0	
	Radius-ulna,	13	0		0	0	

	distal						
	Femur, distal	5	1		0	0	
	Tibia, proximal (tibia- diaphysis)	3	1		0	0	
	Total	37	3	92.50	1	0	100
4	Femur, proximal	5	4		0	0	
	Total	5	4	55.55	0	0	0
5	Radius-ulna (proximal)	11	3		0	0	0
	Tibia, proximal	8	1		0	0	0
	Total	24	8	75	0	0	0

A total of 126 camelid bones with a known state of fusion were recovered from the Southern Platform, while only 3 were recovered from Architectural Compound 2. All of these elements were isolated, none were from articulated skeletons. Such a small sample size from Architectural Compound 2 would mean that the results of any statistical testing to determine significance would yield results that are tentative at best. Table 8 is organized so as to compare the number of unfused versus fused bones in the assemblage for each of the skeletal groups. Beginning with the Southern Platform, it appears that the majority of the individuals were adults, since many of these have fused elements in each

of the skeletal age group. None of the individuals in the assemblage were identified to the skeletal age group #1, suggesting that all the individuals represented in this assemblage were older than one year of age. Though we must keep in mind that the small sample size may not reflect actual trends in the data. It is possible that, due to individuals being represented across the different skeletal age groups, people at the Gallinazo Group site had access to a herd of camelids nearby. This idea is further strengthened by the skeletal element distribution which show that the majority of the skeletal portions of the camelids are reflected in the assemblages. Any conclusions made of the age distribution of camelids collected from Architectural Compound are tenuous at best, since only three bones with identifiable states of fusion were found.

3.4.3 Age Structure Model for Analysis of Camelid Teeth Eruption and Tooth Wear Analysis

A few camelid mandibles with intact teeth were recovered during excavation. In the Southern Platform, 14 mandibles with intact teeth were preserved well enough to determine age. In Architectural Compound 2, only two loose tooth fragments were recovered, which could not be aged. Wheeler's (1982) eruption sequence for llamas and alpacas was used to age the mandibles from the platform (Table 9). This sequence was derived using 253 alpaca, llama, and alpaca-vicuna cross mandibles from Peru, all of known ages. Wheeler found few differences among the three species.

Table 9: Mandible Teeth Eruption Sequence for Llamas and Alpacas (based on Wheeler 1982)

Age Class (Months)	Dental Age Class	Erupted Teeth
0-12	1	<ul style="list-style-type: none"> - All three deciduous incisors are normally erupted at birth. - Deciduous canine erupts at around 9 months. - Deciduous lower third premolars. - Deciduous lower fourth premolars. - Lower first permanent molar.
24-36	2	<ul style="list-style-type: none"> - Lower first permanent incisors. - Lower third permanent molars. - Lower second permanent molars
24-84	3	-Lower first permanent canines.
36-48	4	- Lower second permanent incisors.
36-60	5	<ul style="list-style-type: none"> -Lower third permanent premolars. -Lower fourth permanent premolars
60+	6	All teeth have erupted, must use wear analysis to determine age.

Along with her camelid dental eruption sequence, Wheeler (1982) also described and provides detailed drawings for estimating age based on dental wear. Her tooth wear sequences are based on a collection of llama and alpaca mandibles from the National Center for South American Camelids, aged from birth to 14 years. The teeth she uses to

determine age based on tooth wear are the deciduous and permanent third premolars, the deciduous and permanent fourth premolars, the permanent first molar, the permanent second molar, and the permanent third molar. This method, unlike age determination based on eruption, is applicable to teeth from the maxilla (upper jaw) as well as the mandible (lower jaw).

3.4.4 Age Structure of Camelid Population in the Southern Platform Based on Dental Eruption and Wear

Table 10 presents the numbers of camelid mandibles from the Southern Platform attributed to each of Wheeler's (1982) age classes based on dental eruption.

Table 10: Age estimates of camelids from the Southern Platform based on Dental Eruption

Dental Age Class (Months)	Southern Platform Frequency (NISP)	Frequency (%)
(0-12)	1	9.090
(24-36)	7	63.636
(24-84)	1	9.090

(36-48)	2	18.181
(36-60)	0	0
(60+)	0	0
Total	11	100

The majority of the specimens were aged to between 24-36 months age. Five loose teeth from the Southern Platform could also be aged using Wheeler's dental wear sequence. Five loose teeth recovered from the Southern Platform were aged by looking at the amount of wear on the surface. The teeth belonged to animals aged 10 years, 14 years and over, and between 3-4 years of age.

Overall, it appears that a range of ages are represented when taking into consideration epiphyseal fusion data to the frequencies from using dental eruption and wear sequence though the majority of the individuals appear to have been older than 1 year at the time of death. The range of age classes represented in the sample support the possibility that individuals at the Gallinazo Group site may have had regular access to a herd of camelids, most likely kept near or at the site.

3.4.5 Epiphyseal Fusion Sequence Used for Sea Lions (*Otaria flavescens*)

The epiphyseal fusion sequence used in this study to age the sea lion remains was taken from a research published by Borella et al. (2013). They present bone fusion data from species of eared seals, including *Otaria flavescens*. Their sequence, summarized in Table 11, is based on 96 male and female skeletons of known age from Patagonia. Their sequence is based on the study of 96 male and female sea lion skeletons from Patagonia.

Table 11: Sea Lion Epiphyseal Fusion Sequence (based on Borella *et al.* 2013)

Age Class	Skeletal Age Group	Skeletal Element
Yearling (0-1 Year)	1	-Unfused atlas
Juvenile (1-4 Years)	2	-Thoracics; vertebral body/neural arch -Atlas, hemibodies and ventral arch; left hemibody. - Lumbar; vertebral body/neural arch - Cervicals, ventral body/neural arch.
Young Adult (3-9 Years)	3	- Axis; odontoid apophyses/vertebral body - Fibula; caput fibulae/proximal epiphysis - Pelvis; ilium/intermediate/ischium-pubis - Humerus; Head and greater tubercle /lesser tubercle

		<ul style="list-style-type: none"> - Humerus; capitulum/medial epicondyle. - Humerus; medial epicondyle/diaphysis.
Medium-Adult (7-16 Years)	4	<ul style="list-style-type: none"> - Humerus; diaphysis/capitulum - Humerus; diaphysis/lesser tubercle - Calcaneus - Axis; posterior epiphyses/vertebral body - Cervicals; anterior epiphyses/vertebral body - Cervicals; Posterior epiphyses/vertebral body - Lumbars; anterior epiphyses/vertebral body - Lumbars; posterior epiphyses/vertebral body - Sacrum vertebra - Fibula: proximal epiphysis/diaphysis.
Old Adult (Over 16 Years)	5	<ul style="list-style-type: none"> - Humerus: diaphysis / head + greater tubercle. - Ulna; Olecranon crest/diaphysis. - Ulna: distal epiphysis/diaphysis. - Femur: distal epiphysis/diaphysis - Femur: Greater trochanter/diaphysis - Femur: caput ossis femoris/diaphysis - Tibia; proximal epiphysis/diaphysis - Tibia; distal epiphysis/diaphysis - Caudals; epiphysis. - Radius; proximal epiphysis/diaphysis - Radius; distal epiphysis/diaphysis - Thoracics; Anterior epiphyses/vertebral body. - Thoracics: posterior epiphyses/vertebral body

		<ul style="list-style-type: none"> - Ribs; head to body. - Scapula; glenoid cavity.
--	--	---

While their analysis differentiates between males and females, Table 11 summarizes the skeletal changes for both males and females, since sexing was not possible. The "Age Class" column refers to broad age categories in the living population, the "Skeletal Age Group" indicates a series of skeletal development stages and provides a short-hand for the group of epiphyses that fuse at each stage in an individual's life history. The Yearling category (or Skeletal Age Group 1) corresponds roughly with the first year of life of a pup's life. The second age class, "Juvenile" accounts for a period where infants are able to feed themselves but are not yet sexually mature, and ranges from 1-4 years of age. The third phase is divided into three stages, beginning with Young Adult (which spans from 3-9), Medium-Adult (7-16), and Old-Adult (16 and over). There are slight overlaps due to differences in the growth rates of males and females. Females tend to mature skeletally faster than males, meaning that their bones fuse earlier.

3.4.6 Age Distribution of Sea Lions at the Southern Platform and Architectural Compound 2

The results of the analysis are provided in Table 12. Identifying the state of fusion for many of the sea lion remains from Architectural Compound 2 was difficult, with only one specimen with a known state of fusion. On the Southern Platform, meanwhile, we had a

Table 12 presents the relative abundance of each of the skeletal age categories in both assemblages. The Southern Platform produced 12 sea lion elements that could be attributed to an age class based on skeletal fusion, while only 3 such element were present in Architectural Compound 2.

**Table 12: Age Estimates of Sea Lions from the Southern Platform and Architectural Compound 2
Based on Epiphyseal Fusion.**

		Southern Platform (n=12)			Architectural Compound 2 (n=3)		
Skeletal Age Group	Epiphyses	# Fused	# Unfused	%Fused	# Fused	# Unfused	%Fused
3	Pelvis; ilium/intermediate/ischium-pubis	0	2	0	0	2	
	Total	0	2	0	0	2	0
4	Cervicals; anterior epiphyses/vertebral body	0	1		0	0	
	Total	0	1	0	0	0	
5	Humerus: diaphysis / head + greater tubercle	0	1		0	0	
	Ulna; Olecranon crest/diaphysis	1	0		0	0	
	Ulna: distal epiphysis/diaphysis	1	0		0	0	
	Femur: distal epiphysis/diaphysis	0	1		0	0	
	Femur: Greater trochanter/diaphysis	0	1		0	0	
	Femur: caput ossis femoris/diaphysis	0	1		0	0	

	Tibia; proximal epiphysis/diaphysis	0	1		0	1	
	Tibia; distal epiphysis/diaphysis	1	1		0	0	
	Radius; proximal epiphysis/diaphysis	2	0		0	0	
	Radius; distal epiphysis/diaphysis	2	0		0	0	
	Ribs; head to body	1	0		0	0	
	Scapula; glenoid cavity	0	1		0	0	
	Total	8	7	53.33	0	1	0

The majority of the sea lion remains belong to the 5th Skeletal Age Class, suggesting that the majority of the individuals in the assemblage were older adults, with the youngest individuals having been identified as Young Adults. No remains were identified to pups or juveniles, though the assemblages are so small that one cannot with confidence say that any trends can be reflected in the data. The lack of pups or juveniles could potentially suggest that the peoples of the Gallinazo Group site were targeting older seals or, perhaps, were not out hunting seals during the time when mother sea lions come to the beaches to birth their pups. Along with possibly hunting the seals, they may have also exploited the carcasses of dead seals washing up on the shore.

3.5 Modification and Processing of Faunal Remains

The degree of fragmentation and the prevalence of burnt bone in the two faunal assemblages are compared in Figures 16 and 17 to investigate patterns of food processing in the two areas of the site. Figure 16 illustrates the distribution of bone fragments by size category for the two areas, based on the greatest length measurement for each fragment. Both assemblages are dominated by the smallest size category, fragments under 2 cm in length. This pattern suggests that foods were heavily processed before consumption in both areas of the site.

3.5.1 Bone Fragment Measurements

Figure 16: Lengths of Faunal Fragments (%)

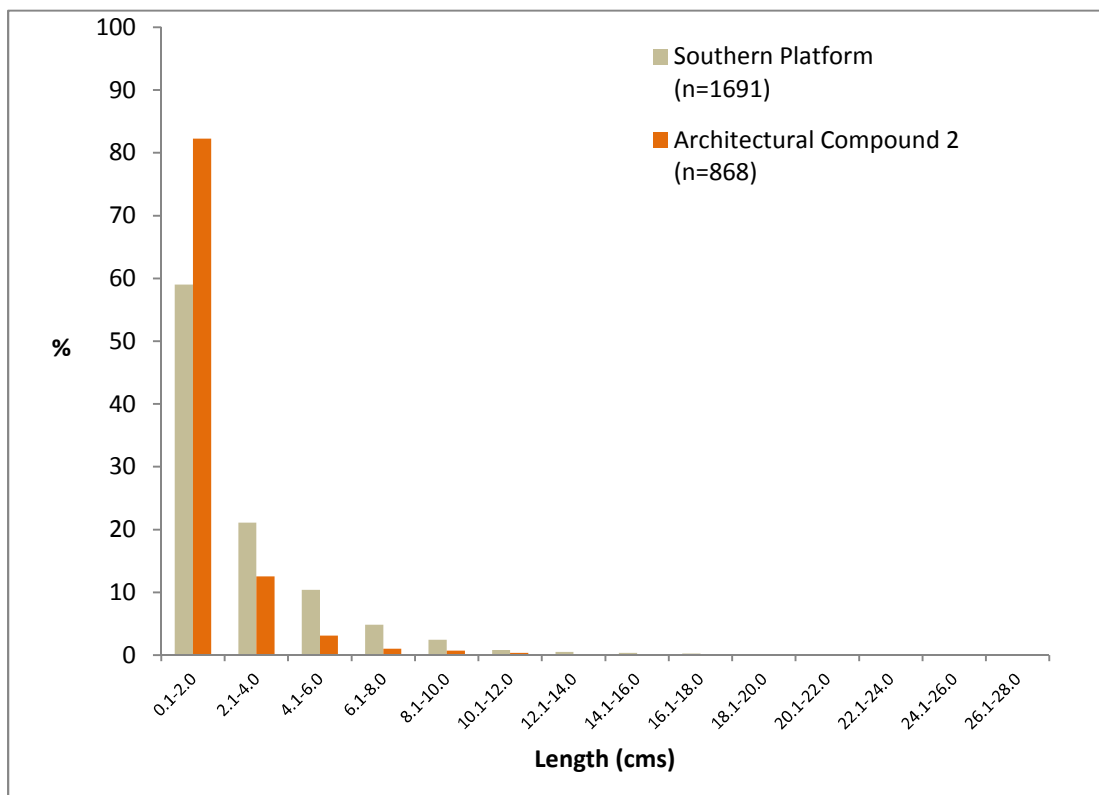

Overall, material from Architectural Compound 2 appears to have been more heavily processed than that from the Southern Platform. More than 80% of the remains from Architectural Compound 2, while on the Southern Platform only 58% of the remains fell between 0.1 and 2.0 cm's. No fragments greater than 12 cm in length were recovered from the Architectural Compound 2, though some are present in the Southern Platform, they only account for approximately 1.4% of the total assemblage.

While bone fragmentation rates are related not just to food processing but also to preservation conditions, the similar depositional environments on the Southern Platform and in Architectural Compound 2, and the excellent organic preservation observed across the Gallinazo Group site (such as textiles being recovered) suggests that the observed differences in fragmentation rates are more likely tied to differential processing than differential preservation.

3.5.2 Burnt and Unburnt Bones

Figure 16 indicates the percentage of bones in each area of the site that were unburnt, burnt, and calcined. Burnt bone takes on a black colour, and is subjected to lower temperatures than calcined bone, which is burnt at hotter temperatures and takes on a bluish-white or white appearance.

Figure 17: Percentage of Burnt, Calcined, and Burnt Bones from the Southern Platform and Architectural Compound 2

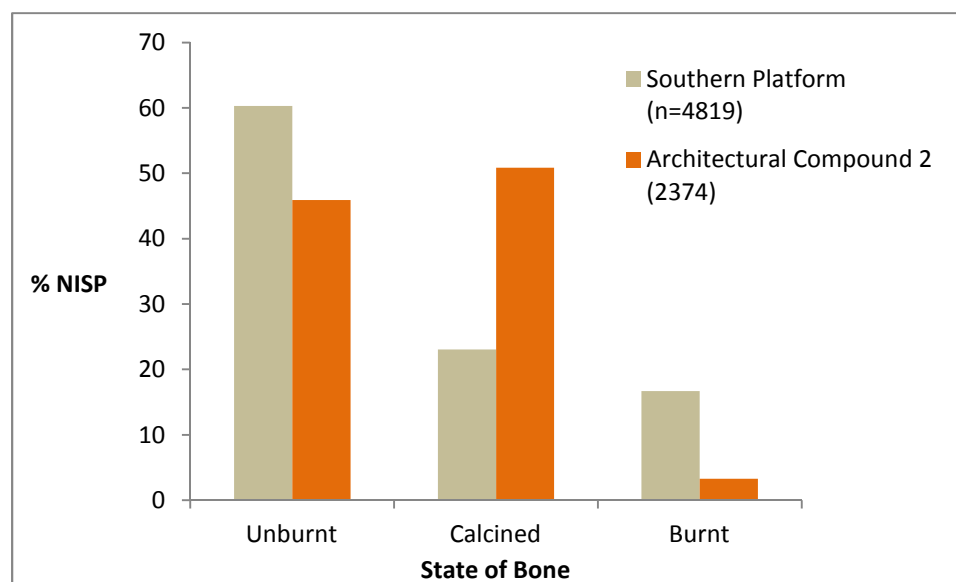

Overall, unburnt bones dominate on the Southern Platform, forming approximately 60% of the assemblage, followed by roughly equal proportions of calcined and burnt bones, at 23% and 16% respectively. In Architectural Compound 2, calcined bone are most abundant, forming 51% of the assemblage, followed closely by unburnt bone at 45% and with a limited amount of burnt bone at 3%. Pearson's Chi-Square test was used to test the statistical significance of the relationship between the variables in the two excavated areas of the site, with a p -value of $\chi^2(2, 7183) = 0.000$; $p < 0.01$. This suggests that the results are statistically significant.

The differences between burnt and unburnt bone and their distribution in the two different areas of the site suggest the existence of differences in processing and cooking methods were used, due to different consumption activities which occurred between these two parts of the site. The evidence of highly fragmented skeletal elements, smaller fish vertebra, and the higher abundance of molluscs all seem to suggest different types of

meals were served in Architectural Compound 2 compared to the Southern Platform, where we see bigger mammalian skeletal parts and bigger fish overall.

3.6 Summary

Overall, mammals dominated both assemblages, with camelids and sea lions being particularly abundant. Among bird species, four in particular were more represented in both sectors: gulls, cormorants, boobies, and the Humboldt Penguin. As for fish, three species also dominated the assemblages from both sectors: the Peruvian banded croaker, drum fish, and sardines. The dominant skeletal parts of the camelid and sea lions skeletons on both the Southern Platform and in the Architectural Compound 2 were most elements from the limbs and the axial portion of the skeleton, with the Southern Platform having a relatively high frequency of phalanges as well. The distribution of the skeletal portions of camelids may suggest that entire skeletons were processed at or near the site. We also see elements of the head and feet being prevalent despite these not having much meat on them. It is also possible that the less meatier portions of a skeleton, such as their phalanges, were used in the creation of instruments, and tools. As for the skulls of camelids present on the Southern Platform, these may relate to certain ritual activities.

The majority of the camelid remains identified or recovered were aged to over 1 year of age. As for sea lions, the majority that were older than three years of age, with the majority of these being over 16 years old. This may suggest seasonal hunting patterns of sea lions by the Gallinazo Group people or may be linked to their preference for hunting

meatier adults. In both areas excavated, the remains were highly processed with the majority falling in the range of 0.1-2.0 cm's. No elements over 12 cm's in length were found in the Architectural Compound 2, though some were found in the Southern Platform. The higher proportion of longer fragments in the Southern Platform may suggest that the meals that were served in this context were different than those prepared in the Architectural Compound 2, relating perhaps to differences in public and private consumption. Lastly, that the majority of the fragments were calcined in the Architectural Compound, while most were unburnt on the Southern Platform, may also relate to different processing and cooking techniques that took place in these two different contexts.

Chapter 4

4 Discussion

This chapter contextualizes the faunal data from the Gallinazo Group site with other lines of evidence such as architecture, ceramics, and Moche iconography. Possible explanations for differences in consumption activities in the two areas of the site will be explored, focusing particularly on ritual and political feasting. Next, I explore similarities and differences between faunal assemblages from the two excavated areas of the Gallinazo Group site in further detail and compare them with neighbouring sites, primarily from the Moche Valley, in order to place them within a regional context. Overall, the faunal evidence collected from the Moche Valley is similar to that from the Gallinazo Group site, particularly in terms of which species make up the bulk of the assemblages, and the relative abundance of these species. Finally, I describe the different ecological habitats that were exploited by the occupants of the Virú Valley, and provide evidence for camelid herding practices on the north coast.

4.1 Consumption Activities at the Southern Platform and Architectural Compound 2

This section will provide additional lines of evidence from the Southern Platform and Architectural Compound 2 that can be usefully integrated with the faunal evidence to interpret the activities and consumption practices that took place in both areas.

4.1.1 Contextual Evidence

The Gallinazo Group site was dominated by Huaca Gallinazo: a towering structure that featured a stage-like platform (Southern Platform) decorated with friezes and wall niches that fronted a wide plaza, presumably used for large public gatherings and ceremonial activities (Millaire 2010). This architectural pattern (stage-like platform fronting plaza) was also popular on contemporaneous sites in neighbouring valleys, where it is usually associated with large public gatherings and ritual activities, including the display of war captives brought here for sacrifice (Millaire 2010; Quilter 2001). In this context, the Southern Platform is hypothesized to have been a space used by the local ruling/priestly elite for the performance of integrative rituals, the nature of which is still unknown.

Excavations on the Southern Platform led to the discovery of a number of burials, some of which may correspond to child sacrifice (Millaire and La Torre 2009). Elite ceramic vessels were also uncovered in this context, including Virú corporate ware (Gallinazo Negative) as well as Callejón ceramic vessels that may have been brought to the site through trade (Millaire and La Torre 2009, 2011). These types of pottery were seldom found in the residential area of the site.

Based on information from contemporaneous settlements on the north coast, access to the Southern Platform would have been restricted to a selected few who took part in more private activities that could have included such rituals as oracle consultation, sacrifice (food, material offerings, human, etc.), and feasting ceremonies (Millaire 2010): a form of integrative ritual that usually occurred in special halls, patios, or gathering areas in ancient societies (Hayden 1996). Although there is currently no direct evidence of

feasting on the Southern Platform, evidence of meal preparation and discard was uncovered in adjacent rooms. Excavations in rooms A7 and A8 revealed the presence of cooking hearths as well as large quantities of food remains and cooking vessel fragments (Masur 2012; Millaire and La Torre 2011).

Desiccated and charred botanical remains recovered from the Southern Platform and from Architectural Compound 2 (screen collection and flotation sampling) were analyzed by Lindi Masur (2012) who found that three plants had a markedly different distribution between the two contexts: maize, squash, and peanuts. Maize (cobs and kernels) was more ubiquitous in Architectural Compound 2 (85.2 percent of all plant fragments recovered) than it was on the Southern Platform (30.4 percent). Conversely, squash (seeds) was more ubiquitous on the Southern Platform (44.9 percent of all plant fragments recovered) than it was in Architectural Compound 2 (only 1.3 percent). Finally, a large quantity of peanut fragments was recovered from the Southern Platform, but none were found in Architectural Compound 2. Masur found that peanuts were in fact the third-most frequent comestible plant found on the Southern Platform, (after maize and squash) and also noted that peanut shell fragments were also found associated with a possible human sacrificial offering in this context. On the basis of this and other lines of evidence, Masur argued that peanuts were primarily associated with civic-ceremonial architecture in Virú society, and that this crop probably played a key role in certain consumptive acts, including burial offerings and feasting (Masur 2012).

As outlined in Chapter 3, the faunal remains from the Southern Platform and Architectural Compound 2 differ in several important ways. First, the faunal assemblage collected from Architectural Compound 2 was smaller and more fragmented than that

from the Southern Platform. Secondly, while mammals dominate in both contexts, fish are the second-most abundant class in Architectural Compound 2 while birds take this position atop the Southern Platform. In addition, a much higher proportion of the bones from Architectural Compound 2 were burnt and calcined.

How might we account for these differences? So far, archaeological investigations at the Gallinazo Group site indicate that the Southern Platform likely served an important political and ritual role, a public space overlooking a wide plaza that could accommodate large gatherings. This context suggests that it was the site of public performances, though details of these performances, by whom they were orchestrated (elite individuals or groups, religious and/or political figures), and for whom (local residents and/or people from the surrounding region, people of a particular social standing or of varying status) remain difficult to determine.

The precise function of Architectural Compound 2 is less clear. It appears residential in nature, though the presence of a small plaza-like floor within the compound may indicate that small gatherings took place. It may therefore not represent a strictly private residential context that can be interpreted in direct contrast to the “public” space of the platform. Whether or not the food remains from either context reflect exclusively “private” or “public” consumption, the clear differences between the two faunal assemblages indicate distinct activities and patterns of consumption in the two sectors. A possible explanation for these differences lies in the politically and ritually important tradition of feasting.

4.1.2 Feasting in the Archaeology Record

Archaeological evidence indicates that feasting occurred in many ancient complex societies, and involved the social consumption of certain foods, usually in a ceremonial or ritual context (Dietler and Hayden, 2001). Feasts were carried out for various purposes, sometimes organized by important elite, religious, or political members of a population (Chicoine 2011), often in the hopes of solidifying their social position (Pauketat et al. 2002). These feasts may have been held by elite members for their entire community, or may have been more exclusive, involving only elites from within or outside the community.

Feasting generally differs markedly from day-to-day food consumption and can be identified through architectural characteristics, evidence for large scale food preparation, particular serving vessels, and special kinds of food and drink. At pre-Inca and Inca sites in Peru, several investigators have connected the large open plazas, benches, and patio rooms with feasting activities (Garcilaso de la Vega 1987; Morris and Thompson 1985; Morris 1988; Pozorski and Pozorski 2002, Chicoine 2006, 2010, 2011; Brewster-Wray 1990). Feasting activities can also be identified through the presence of specialized, often highly decorated, feasting equipment and serving vessels (Adams 2004). The quantities of food that must be prepared for large feasts would require a large amount of cooking, storage, and serving equipment (Chicoine 2011). These serving vessels may be distinguishable from every-day serving ware not only because of their size, but because they may also be finely crafted, made of exotic materials, or obtained through long-distance trade (Hayden 1996). In some cases, feasting involved foods similar to everyday

meals, but feasting events are distinguished by the sheer quantity of foodstuffs. In other cases, feasting events are indicated by the presence of exotic and foreign species in the assemblage, quality cuts of meat, or particular species being more abundant, perhaps due to their symbolic importance.

4.1.3 Possible Feasting and Ritual Consumption at the Southern Platform

The very public architectural context of the platform suggests that it was a site where public performances, likely associated with ceremony and ritual, took place. Faunal evidence collected on the Southern Platform can also be linked to ritual activity, since some of the species represented in the assemblage are depicted in ritual scenes on Moche vessels. Ritual feasting, the consumption of ceremonial foods by large or small groups of people may have potentially been carried out on the platform is. The archaeological record from the Andes has documented feasting in many contexts (Hastorf 1993; Murra 1980), and it has also been documented on the Peruvian north coast (Chicoine 2011; Ikehara 2013). It is likely, based on the evidence outlined above, that such activities also took place at the Gallinazo Group site, though further investigation is required to confirm this suggestion, and it is also possible that ritual activities other than feasting were taking place at the site.

4.2 Placing Consumption Activities at the Gallinazo Group Site in a Broader Regional Context

This section elaborates on the similarities and differences between the faunal assemblages collected from the Southern Platform and Architectural Compound 2, and contextualizes those data within broader patterns of subsistence and consumption on the Peruvian north coast. The neighbouring Moche Valley provides a useful point of comparison because there are several published faunal analyses from its sites and because it is environmentally similar to the Virú Valley.

4.2.1 The Mammalian Assemblage

Camelids were the most abundant mammalian species in both the Southern Platform and Architectural Compound 2 at the Gallinazo Group site, with sea lions a distant second. A similar pattern is also seen in the Moche Valley. Faunal remains from the Moche capital city of Huacas de Moche are dominated by camelid and, to a much lesser degree, sea lion remains in both domestic architecture and two large corporate buildings (Uceda *et al.* 1995-1999). These platform mounds (Huaca de la Luna and Huaca del Sol) are interpreted as the site of ritual activities. Shelia Pozorski (1979) has argued for two important shifts in faunal exploitation between Early Horizon and Early Intermediate Period sites in the Moche Valley. The Early Horizon sites of Gamalote and Caballo Muerto show a strong emphasis on shellfish procurement and fishing, and terrestrial resources were dominated by deer. The Early Intermediate period sites in the valley were

dominated by camelids. Pozorski argues that these differences reflect a temporal increase in the importance of terrestrial versus marine resources overall and shift in focus amongst terrestrial species from deer to camelids. The predominance of mammals over fish, bird and mollusc and the relatively low numbers of deer remains versus camelids at the Gallinazo Group site, provide further evidence for these temporal trends.

Based on depictions on Moche vessels of elaborately dressed men with throwing sticks or clubs hunting deer, Izumi Shimada (1996) has argued that deer hunts were ritually and symbolically important events among the Moche, associated with elite ceremonialism. Interestingly, the few deer remains at the Gallinazo Group site were all found atop the Southern Platform, which may indicate a similar link between deer and ritual activity at the site.

While the mammalian assemblages collected from both areas of the site were dominated by camelids, the average length of these fragments differed. The camelid remains from Architectural Compound 2 were more fragmented, suggesting that they were heavily processed, perhaps for marrow and grease extraction. Camelid remains from the Southern Platform tended to be larger, suggesting that grease and marrow extraction were not as heavily emphasized.

Sea lions also appear to have been an important marine resource among the occupants of the Gallinazo Group and are well represented in both areas of the site. There are Moche iconographic representations of sea lion hunts by men bearing clubs. These depictions suggest that sea-lion hunting was a valued activity among the Moche. Of all the surviving media, Moche ceramic arts are the best known and most intensively studied, and

represent the largest iconographic sample for research on Peruvian north coast societies (Jackson 2008). Moche ceramic art is closely bound with ideology, its depictions centered primarily on ritual and the supernatural rather than everyday life (Jackson 2008). Given the close association between ceramic art and ideology, the depiction of sea lion hunts on Moche vessels suggests a ritual aspect to at least some sea lion hunts in this society. Sea lions represent a much larger proportion of the mammalian assemblage at Architectural Compound 2 than on the Southern Platform, suggesting that either sea lions were not consistently associated with ritual at the site, or that ritual was more important at Architectural Compound 2 than indicated by the other lines of evidence.

Sea-lion epiphyseal fusion from the Gallinazo Group indicates individuals ranging from 3 to over 16 years of age, with the majority of the individuals falling in the age category of 16 years and over. While the very small sample size of ageable epiphyses makes it difficult to draw any firm conclusions, one could speculate that the abundance of adults in the assemblage is due to hunters targeting fully-grown individuals with higher meat yields. Like the age data, the skeletal portion data was derived from a relatively small sample and therefore any conclusions reached are tentative. Most parts of the skeleton are represented, suggesting that sea lions were hunted locally, with limited butchery and discard prior to transport. Interestingly, as with camelids, sea lion femurs are rare on the Southern Platform and are completely absent in Architectural Compound 2. Again, this may simply result from the vagaries of small samples, but the paucity of femurs bears further investigation once larger samples are recovered. If these elements are under-represented in larger samples, it may reflect their deliberate removal for consumption or use elsewhere.

Along with camelids and sea lions, dog remains were also found in both areas of the site. Dogs also figure in Moche iconography, where they are often depicted as the companions of important mythical figures (Donnan *et al.* 1979). Dog effigy vessels have also been found on Moche sites (Benson 2012). While dog iconography has not yet been identified at the Gallinazo Group site, they may have been similarly valued by the occupants of the Virú Valley, serving as useful companions. The presence of a dog femur bearing cutmarks may also suggest that they were occasionally consumed.

Guinea pig was found in both sectors of the site, constituting a slightly higher proportion of the faunal remains in Architectural Compound 2 than atop the Platform, though the difference is not statistically significant ($\chi^2(3, N = 52) = 5.53, p = 0.13$). Guinea pigs have been conspicuous as domesticated animals on the coast and the highlands (Sandweiss *et al.* 1997). They are considered a delicacy, and are often associated with ritual sacrifice. They are also used in medical diagnoses. Guinea pigs are found in the archaeological record of the Andes as far back as 9000 years ago, and were domesticated by 2500 B.C (Sandweiss *et al.* 1997). After 2500 B.C. they begin to appear in ritual contexts, and were used as sacrificial offerings during ritual events and ceremonies (Sandweiss *et al.* 1997). Unlike in the highlands, guinea pigs do not appear to have been particularly popular among coastal communities until the Early Intermediate Period, when they were used both for their meat and as sacrificial offerings (Sandweiss *et al.* 1997; Donnan *et al.* 1978; Kent *et al.* 1994). As with sea lions, then, guinea pigs may have fulfilled a ritual role on the north coast of Peru, as well as being a source of food.

4.2.2 Mollusc, Fish, and Birds

Land snails, beach clam and several species of sea snails were well represented in both contexts at the Gallinazo Group, and the beach clams were mollusc species also highly represented in the urban zone of the Moche capital (Rosello *et al.* 2001; Uceda *et al.* 1997, 1998, 2000, 2003). Interestingly, in the case of molluscs, the land snail was only present in the Southern Platform which could suggest that it was associated with civic or ceremonial activities. On the north coast of Peru, land snails were and are still hand-collected by travelling to the Andean foothills, where they can be found in the *lomas*, or pockets of fog-vegetation (Vásquez Sánchez, V. F, personal communication: November 3, 2013).

For land snails to be consumed, they must first be purged of their psychoactive substances (Chicoine 2011). Given the context in which they were found at Huaca Gallinazo, it is possible that people willingly consumed undercooked or raw snails so as to be under the influence of its psychoactive properties. The use of psychoactive plants has been detected in Peru's archaeological record, in the form of implements used in the preparation and consumption of psychoactive substances (Burger 1992). Less direct evidence is found in the presence of plants that are known to have psychoactive properties (Burger 1992). The use of psychoactive plants in Peru has been documented in Chavín (Burger 1992) and Moche (Carod-Artal *et al.* 2007; Dobkin-Rios 1977; Furst 1974) cultures. Snails are also a common theme in Moche ceramic art, including themes of costumed men gathering tree snails in the Andean foothills (Bourget 2006). Zoomorphic stirrup-spout vessels in the forms of land snails have also been found in

ceremonial contexts at Moche sites (Donnan 1978). That being said, at Huaca Gallinazo land snails may simply have been served as delicacy during feasts. Whether they were consumed for their psychoactive properties or as culinary delicacies, their presence on the Southern Platform and absence in Architectural Compound 2 minimally suggest an association between these molluscs and elite consumption.

Donax obesulus, the common beach clam, was one of the most common species in the mollusc assemblages from both areas of the site. This species is commonly found along Peru's northern beaches, and is easily collected by hand in large numbers (Chicoine *et al.* 2012). The presence of *Donax* shells in both contexts could suggest that they were also part of consumption activities. A traditional practice still seen today on Peru's northern coast is the grinding of *Donax* shells for the production of lime. The lime is then used in the consumption of coca (Sandweiss 1979). The presence of *Donax* shells at the Gallinazo site may not only indicate that they were consumed, perhaps in the form of stews or soups (Sandweiss 1979; Chicoine 2011), but were also very important for the consumption of coca. Other species of molluscs present in the assemblage, such as rock mussels and sea snails that inhabit rocky outcrops along beaches, and would have been exploited at low-tide. Additionally, various species of sea snails such as *Thais haemastoma* and *Thais chocolata* were also present in both areas of the site. The bulk of mollusc species represented at the Gallinazo Group are intertidal, living in the areas between low and high tides along shorelines, and therefore areas that would have been easily accessible.

Marine species from a range of different habitats dominate the fish assemblage, suggesting that the occupants of the site used a variety of fishing technologies to exploit

different marine environments. Sardines, for example, live in relatively shallow waters of the beaches and could have easily been caught by casting a large net. Other species of fish, however, such as the Peruvian banded croaker and drum fish live at or near the bottom of the ocean, and would have been caught using fishing lines or drop-nets from rafts (Bourget 2008). Moche iconography includes fishing scenes depicted on ceramics, with representations of fishermen casting lines from rafts to (Donnan 1978). The higher frequency of marine fish in Architectural Compound 2 compared to bird and mollusc remains suggests that like the Moche, the occupants of the Virú valley valued these resources. The higher proportion of fish in Architectural Compound 2 than on the Southern Platform may reflect their value as a food staple, perhaps in the context of every day consumption of the individuals who lived in Architectural Compound 2. They may be less abundant on the Southern Platform because they played a less important role in feasts and ceremonies.

Bird species are well represented in zooarchaeological assemblages from the Moche Valley as they are at the Gallinazo Group site. Moche sites feature higher proportions of duck and dove than observed at the Gallinazo Group site, suggesting that these species played a more important role in Moche diet. The most important birds in both areas at the Gallinazo Group site are marine species including gulls, penguins, boobies, and cormorants. The dominance of marine birds is not surprising, given the proximity of the site to the coastline. All four categories of birds occupy relatively similar environments. The Guanay Cormorant, which figures in Moche ceramic scenes, is found primarily around shallow seawater and rocky outcrops along the shore (Benson 2012). It is the main producer of bird *guano*, or bird feces, on the islands off the shore of Peru

(Weimerskirch *et al.* 2012). The booby is another important *guano* producer, inhabiting rocky outcrops and is also represented in the bird assemblage in both areas of the site. Seagulls are present in both areas of the site as well, and are found in more diverse environments, including inland wetlands, beaches, and rocky beach outcrops. Humboldt Penguin bones were identified at the site, some showing evidence of cut-marks and exposure to high temperatures, suggesting they had been cooked. This species is found on islands and rocky coasts, where it nests in burrows in *guano* or in caves.

The association of these bird species with Peru's *guano* islands is interesting in light of evidence for possible ritual activity by the Moche at these locales, and historic exploitation of *guano* as a fertilizer for maize crops. Sea bird *guano* in South America is mined primarily from small near-shore islands in the region affected by the Peru-Humboldt upwelling (Szpak 2012). Historical documents dated to the middle of the sixteenth century describe how *guano* was obtained using rafts and used to fertilize agricultural fields (Pedro de Cieza de León 1964). It was particularly crucial for the growth of maize in the northern regions of Chile (Pedro de Cieza de León 1964). The historical use of seabird *guano* on the north coast of Peru is less known, though Moche artifacts and offerings recovered from stratified *guano* deposits on the northern islands of Macabi and Guanape suggest that the islands were the site of at least occasional ritual activities by the Moche (Ashmead 1903; Kubler 1948), perhaps in association with other activities such as *guano* collection or sea bird hunting. However, recent isotopic investigations of human bone collagen from the Moche site of Pacatnamú (Verano and DeNiro 1993; White *et al.* 2009) produced low $\delta^{15}\text{N}$ values, indicating that the Moche were not making use of seabird *guano* as a fertilizer for their crops (Szpak *et al.* 2012),.

Similar investigations at the Gallinazo Group site could reveal whether its occupants were potentially combining sea bird hunting with guano collection at these islands.

4.3 Camelid Exploitation

The South American llama and alpaca were the only species of large mammal to have been domesticated in the Americas (Mengoni Goñalons 2008)). Both belong to the genus *Lama* and they are osteologically similar. Shimada (1985) posits that the sheer abundance of camelid bones and their age structure on various Moche sites indicates that herds of domesticated camelids were present on the Peruvian north coast. He is careful to note that this does not mean that hunting of wild forms of camelids, such as the guanaco, did not occur.

4.3.1 The Many Uses of Camelids: Meat, Transport, Wool, and Dung

Camelids were used in sacrificial rituals on a number of sites on the north coast of Peru. Numerous Moche graves contain llama remains, indicating their use as burial goods (Donnan *et al.* 1979). In some cases, entire llama skeletons were sacrificed and buried in ritual contexts. In their analysis of several Virú Valley sites, Strong and Evans (1952) documented four well-preserved burials of either llama or alpaca, which were interpreted as sacrificial offerings. Further evidence of the symbolic role of camelids comes from the Middle Horizon site of Pampa Grande, where Shimada and Shimada (1981) noted the

presence of sacrificed llamas placed at the bottom of post holes atop the large central pyramid. Sacrificed fetal camelid remains were identified at the Moche site of Pueblo Batán Grande (ca. AD. 450) (Shimada and Shimada (1985). The ritual importance of llamas is further supported by Moche burial iconography, which depicts llamas and llama sacrifice in many funerary scenes (Shimada 1994). Along with their dietary and ritualistic roles, camelids were also particularly useful for transportation, as seen in Moche depictions of llama-caravans (Bourget 2006). Moche outposts located along the coast between the Vicus region on the far north coast and the Huarmay region on the central north coast suggest long-distance trade that likely involved llama-caravans to transport goods (Shimada 1985). Such a practice could explain iconographic representation of llamas carrying backpacks laden with *Strombus* sea shells, fish, and ceramic jars (Bourget 2006; Shimada 1996).

Camelids also provided useful secondary resources, such as wool, hide, sinew, bones for tool-production (weaving implements and flutes), and dung used for fuel and fertilizer (Benson, 2012; Shimada 1996; Szpak 2012). Llama dung has been found in thick layers at some sites such as the Moche V sites of Pampa Grande and Galindo, suggesting that llamas were kept in corrals (Shimada 1996). The use of domestic camelid dung as fuel and in ceramic production has been seen both archaeologically and ethnographically in the region, as evidenced by the presence of camelid feces in kilns and hearths (Benson 2012; Arnold 1993, 1988; Chavez 1984-1985; Jackson 2008). Modern and historic groups also use camelid dung in the cultivation of tubers in the high-altitude *altiplano* and several authors have suggested that it may also have been used to fertilize plant crops

during earlier periods (Szpak 2012; Camino and Johns 1988; Flannery et al., 1989; Garcilaso de la Vega 1966; Yamamoto 1985).

Lastly, alpaca wool was second only to cotton as a fiber in Moche textiles (Uceda et al. 1996; V. Vazquez et al. 2003). In northern Peru S-spinning, a technique used for spinning wool, is typical of the coast, while Z-spinning is a highland trait. All cotton textiles found by Millaire in the Virú Valley were made of S-spun yarns, but when they were embroidered with colored woolen yarns, those were usually Z-spun, which suggest that members of Virú society imported camelid wool yarns, or received them as a form of tribute from people from the highlands or lower (*chaupiyungas*) areas (Jean-François Millaire, personal communication, 5 November 2013; Morris *et al.* 1993). Moreover, stable isotope analyses of those camelid yarns suggest that the animals from which the wool was sheered had lived outside of the lower Virú Valley and at higher elevation (Jean-François Millaire, personal communication, 5 November 2013). Finally, some of the textiles found by Millaire were actually woven according to techniques typical of the highland but unknown on the coast (Surette *et al.* 2010).

These different lines of evidence all suggest that members of Virú society either imported or were supplied with camelid wool yarn and textiles from spinners and weavers who lived at higher elevations. How far high these came from is still unclear, however. That being said, results obtained from the butchered (and sacrificed) camelids from Huaca Santa Clara, Huaca Gallinazo, and Huancaco in Virú present a totally different picture (Szpak *et al.* 2010). They suggest that the animals consumed by local Virú society members were not imported, but were probably born on the coast, where they had lived all their life.

4.3.2 Camelid herding

Archaeologists have questioned whether people of the Peruvian north coast began importing llamas from the highlands and eventually herded their own populations, or whether meat cuts were brought in from highland domestic herds which had been butchered and processed there, then transported to coastal sites (Shimada and Shimada 1985). Llama herding today ranges mainly from the central Ecuadorian highlands to northwestern Argentina (Franklin 1982). Historical and ethnohistoric documents have not provided a clear indication whether coastal communities herded camelids, though physiological studies of llama and alpaca adaptability demonstrate that they would have been able to live successfully in coastal environments, largely due to their digestive efficiency and their dehydration-resistant respiratory system (Franklin 1982; Engelhardt 1975). The varied ecological niches of the north coast include both arid desert and fertile pockets of land that would have created suitable microenvironments for camelid herding (Shimada 1985).

Though the archaeological record suggests that camelids were herded on Peru's north coast, there are no llama herds found there today. Various theories have been proposed to explain this absence, ranging from direct competition with European domesticates such as swine, to the widespread killing of llamas during the Spanish civil wars, and llama mange that occurred circa. 1544-1545 (Horkheimer 1973).

Shimada and Shimada (1985) present the earliest evidence of camelid domestication at an Early Horizon site in the Leche Valley of Lambayeque, located 50km inland from the coast, where camelids seem to have become an important terrestrial protein source. The

presence of most body parts, including foot and skull bones, suggests that people were not importing llama meat, or *ch'arki*, a Quechua word for the dried meat-bearing parts of llama and alpaca, common in the highlands. Unlike the jerky familiar in North America, *ch'arki* incorporates the bones within the meat (Miller *et al.* 1995). Traditionally, the head and lower leg elements are not included in the *ch'arki* trade, and should be absent if camelids were arriving on the coast in this form (Miller *et al.* 1995; Shimada 1985). Rather, the abundance of camelid remains at Lambayeque and the representation of all skeletal portions suggests that camelids were herded locally.

The presence of all parts of the camelid skeleton and the wide range of ages represented at the Gallinazo Group site suggest that its occupants had access to a local herd of camelids. The distribution of camelid skeletal portions at the site is interesting for several reasons. First, almost all skeletal portions are present in both excavated areas of the site. The presence of head and distal limb elements, which have little food value, suggests that people had access to camelids nearby and were processing whole skeletons on-site, rather than transporting the remains over longer distances, which generally involves selection of only the meatier parts (Binford 1984). Camelid foot and head elements are less well represented in both excavated areas than other skeletal parts, which suggests that a degree of preliminary butchery and discard sometimes took place before the camelids were brought to the platform or the architectural compound. However, the femur, which is one of the meatiest portions of the skeleton, was not identified in the assemblage from Architectural Compound 2. Camelid femurs were identified in the Southern Platform, though were not as abundant as the lower front and hind leg elements. This is not a pattern we would expect to see if people were choosing portions of the skeleton only for

their meat. It is possible that these portions of the skeleton were valued for other reasons, perhaps to make tools or instruments which were fabricated in another area of the site that has yet to be excavated. Alternatively, the paucity of upper hind limb elements from Architectural Compound 2 could be a product of the small sample size, and further excavation in both areas may identify these “missing” elements.

The camelid assemblages from both areas of the site includes individuals with a range of ages. Epiphyseal fusion indicates that individuals ranged from 12 months to over 60 months of age. The vast majority fall between 12-36 months of age, when they are either approaching or have attained adult size. Dental eruption and wear analysis of camelid teeth recovered from both contexts shows a range of 0 to 48 months, with the majority falling between 24 to 36 months. While the epiphyseal fusion data did not show the presence of individuals in their first year of life, one mandible specimen was from an individual younger than 12 months. These ages suggest that most individuals were killed in their second or third year of life, shortly after reaching full body size. From a husbandry perspective, this is when they have the best cost-benefit ratio in terms of meat return versus investment in care. It therefore appears that the majority of camelids at the site were used for their meat. Of course, some of these younger individuals may have been used for carrying cargo before being culled. The few older individuals represented in the assemblage may also have served as beasts of burden, while others may have been females kept as breeding stock. The majority of camelids, then, were used primarily for consumption with some having fulfilled other roles such as carriers. These results are similar to those seen in Shimada and Shimada's (1979) study of camelid population structure at the site of Pampa Grande and Cerro de los Cementerios, with the majority of

individuals falling between their first and second year of life when they would have been culled for their meat, with some individuals surviving well into their fourth year of life, suggesting a diversified use of camelids.

This pattern of camelid husbandry focused on meat production differs from that observed at the Moche ceremonial city of Pampa Grande in the Lambayeque Valley, occupied between A.D. 570 and 610. There, camelids also dominate the mammalian assemblage (Shimada and Shimada 1985). The population includes individuals ranging from fetal to adult, and as at Gallinazo Group, Pampa Grande, and Cerro de los Cementerios, a large proportion of individuals were between the ages of 24 and 30 months, which the authors interpret as the culling of young adult males at their prime weight. However, nearly half of the aged individuals from the assemblage lived past 42 months of age, which Shimada and Shimada argue indicates their use for different purposes, with older females and some males exploited as beasts of burden, for their wool, and as breeding stock.

Differences among sites in the abundance of older individuals within the camelid population suggest a diversity of camelid husbandry practices in the region.

The camelid skeletal part and age data from the Gallinazo Group site indicates that its occupants had access to a local herd of domesticated camelids. The sheer abundance of camelid remains at the site strongly suggests that camelids were an important source of meat. The presence of camelid dung in food-processing locales in both excavated areas suggests that camelid dung may have been used as fuel for cooking. While local herds may account for the majority of camelid meat consumed at the site, it remains possible that the community was also importing camelid *ch'arki* from the highlands. Ongoing stable isotopic analysis of the camelid remains collected in 2011 at the Gallinazo Group

suggest that at least a portion of the population, and more likely the entire population, was raised on the coast (Szpak 2013).

Historic and ethnographic documents support our interpretation of camelids having fulfilled a number of different functions in the Andean region, having also been useful as beast of burdens and sources of dung, bones, sinews, hides, and wool for textile production (Mengoni Goñalons, G. 2008; Orlove 1977, Franklin 1982, deFrance 1996; Surette *et al.* 2010; Szpak *et al.* 2010). However, recent stable isotopic analysis of textiles found at the sites of Huaca Santa Clara and the Gallinazo Group has revealed that the wool was not obtained from local coastal camelids, but more likely from camelid populations from the upper valley and highlands (Surette *et al.* 2010). If past trade patterns among Andean communities resembled the historical caravan trade, it is likely that, along with textiles and tubers, merchants also traded llama fat and hides (Browman 1975). Animal hides were found during excavations at the Gallinazo Group site in 2011, though whether they are camelid hides has yet to be determined (Millaire, personal communication July 28, 2013).

4.4 Summary

Site architecture and layout of the Gallinazo Group suggest that the Southern Platform was a place where local rulers or priestly elites may have performed integrative rituals. The discovery of burials atop the platform, the presence of fancy ceramics, seldom found in residential areas of the site, and the abundance of peanuts, which have been linked to

civic-ceremonial contexts, all further support this hypothesis. Furthermore, information from contemporaneous settlements on the north coast of Peru suggests that the Southern Platform was restricted to a few selected individuals who took place in ceremonial activities, such as feasting. The faunal assemblages from Architectural Compound 2 and the Southern Platform differ in important ways. The Southern Platform assemblage is larger, less fragmented, less burnt, and includes fewer fish and more deer than Architectural Compound 2. These differences may result from the ceremonial role of food consumption on the platform versus day to day consumption in Architectural Compound 2.

Faunal data from the Gallinazo Group site fit within broader regional trends. Overall, the same species seem to be the most highly represented in both contexts, though they differ in their relative abundance. In both contexts, mammals were the most represented, with camelids making up the bulk of each assemblage. Other contemporary sites show similar emphasis on camelids. The age structure of the camelids represented at the Gallinazo Group site indicates that the majority of individuals were culled at the ages of 2 to 3 years, indicating their use primarily for meat. The age ranges represented could suggest that the occupants of the site had access to a local herd.

Chapter 5

5 Conclusion

This thesis has aimed to use the faunal remains from the Gallinazo Group archaeological site in Peru's Virú Valley to investigate patterns of consumption in one of the first state-level societies to develop in the region. The main objective was to compare the consumption of faunal resources in two areas of the site: the Southern Platform and Architectural Compound 2. Previous zooarchaeological studies that have focused on understanding how food waste reflects different activities such as private-domestic consumption and more public events have been helpful in interpreting the faunal assemblages collected from the Gallinazo Group site, since they present examples of complex societies where foods were utilized in trade and exchange networks, ritual activities, and negotiating and signifying socioeconomic status (deFrance 2009: 106). The relationship between food, political, and social life is complex, and these studies have highlighted the ways in which faunal evidence can be interpreted to better understand processes and factors in place for the development of complex ancient societies and urbanization.

5.1 Consumption Practices

This thesis is an attempt to use faunal remains to understand the processes of early state formation on the north coast of Peru. It identified both parallels and differences between the two assemblages that speak to consumption practices and camelid husbandry practices integrated within the broader socio-political context. The samples collected

from both areas of the Gallinazo Group site were dominated by mammalian species, particularly camelid and sea lion. The majority of sea lion and camelid skeletal parts were represented in the assemblages, suggesting that camelids may have been herded locally and that sea lions were hunted locally and brought back whole to the site. The representation of both younger and older camelids in both assemblages further indicates the exploitation of a camelid herd at or near the site. Among the bird species most represented in both assemblages were the gull, the cormorant, the booby, and the Humboldt Penguin. These four species of bird are found along Peru's coastline, as well as inhabiting islands off the Peruvian coast. The discovery of Moche artifacts at these islands suggests that they were visited by the Moche and, quite possibly, by the occupants of the Virú Valley. The diverse fish species at the site represent both deep and shallow marine environments, suggesting that these people utilized a range of technologies such as fishing nets and rafts to exploit fish living at different depths. Lastly, the most abundant mollusc species at the site were the common beach clam, mussel, land snail, and sea snail. These species range from low to high intertidal zones and once again point to the exploitation of a diversity of habitats by the site's occupants.

The faunal remains collected from the two contexts differed in the range of species represented and their relative abundance. Deer were completely absent in Architectural Compound 2. Additionally, there were differences in the degree of burning and the degree of fragmentation of the two faunal assemblages. Taken together, these differences suggest that different consumption activities took place in these two areas of the site, with consumption atop the Southern Platform possibly of a ritual nature. The architectural, artifactual, botanical, and faunal evidence also suggest that Huaca Gallinazo represents a

ritual or ceremonial context. Meals that were served on the Southern Platform may have been served during feasts or ceremonies, and the larger bone fragments found could suggest that roasting of meat cuts occurred more often than in Architectural Compound 2, where bones were highly processed. This evidence, combined with the many small fish and molluscs may suggest that meals in the form of soups and stews predominated and/or that grease and marrow extraction was more commonly practiced in Architectural Compound 2.

Despite these differences between the two assemblages, the overall picture is one of broad similarity between both contexts. Feasting may be suggested on the Southern Platform based on the sheer abundance of faunal remains and the presence of two species, deer and snail, which are absent below in Architectural Compound 2. Deer are clearly linked with high status ceremonial hunts in Moche iconography, and may be similarly linked with status and ritual in this context. The land snail (*scutalus sp.*) may have been consumed for its psychoactive properties, which may similarly suggest a ceremonial affiliation (Donnan 1978). Moche iconography also includes depictions and effigy vessels of various guano-producing bird species, such as the cormorant, suggesting that these may have held some sort of ritual or symbolic significance (Benson 2012). The broad similarities between these two contexts may indicate the foods consumed by more elite members of society, though for different purposes, with the Platform Mound representing a more public, ceremonial context of consumption, and the Architectural Compound more representative of day to day consumption practices. To better understand the meaning of these similarities and differences, we require additional faunal

assemblages from variability wider range of contexts at the site, which must await further excavation.

5.2 Contributions

This research has contributed to a broader research investigation of the Virú Valley, led by Jean-François Millaire who is interested in better understanding early city life during the first millenium of the current era, while also elucidating the processes and factors involved in the development of state-level society in the Andean region. The development of state society meant a feeding a growing population, with certain individuals such as the elite, administrators, bureaucrats, and specialized craftsmen relying on farmers, fishermen, and hunters to feed them. The increased social differentiation within early states meant that elites often had preferential access to valued goods (Bauer *et al.* 2002). In the Andean past, elites and ruling priests asserted and maintained their authority through ties to the supernatural, and organized and participated in ritual and ceremonial events held at civic-ceremonial centers (Castillo *et al.* 1996). How, then, could consumption activities be linked to increased social differentiation and the emergence of a state at the Gallinazo Group archaeological site?

This project was the first to use faunal evidence to better understand state formation in the Virú Valley, and further emphasizes the value in analyzing faunal remains to better understand the economic, political, and social processes in place in the development and survival of state-level societies. The Early Intermediate Period in Andean prehistory was a time of great change, with the emergence of urban life and state-level societies along Peru's north coast. The occupants of the Gallinazo Group site lived in a geographically

diverse area, exploiting marine resources and terrestrial resources, and producing agricultural crops. They practiced camelid husbandry, and kept domesticated dog and guinea pig. Differences in camelid age profiles between the Gallinazo Group site and neighbouring ones support Szpak's (2013) interpretation based on isotopic evidence that camelid husbandry was practiced locally on the Peruvian north coast, and that these practices varied, perhaps from household to household, unlike larger scale more consistent camelid husbandry practices known historically in the highlands. Textile evidence, however, paints a more complex picture of continued importation of highland textiles despite the presence of camelids on the coast. Further research will hopefully shed light on this topic.

The input of labour and energy into these food practices suggests that increased control and exploitation of natural habitats in the region went hand in hand with state-emergence. Such control is also seen in the construction of irrigation canals to produce agricultural crops, which reshaped and modified the landscapes around them. Increased food production and food security would have encouraged population growth and the development of a centralized government to distribute surplus, manage irrigation, trade, and defense (Millaire 2010), and may have contributed to increased social stratification as some individuals gained control over production and trade and accumulated more wealth (deFrance 2009).

The analysis and comparison of the faunal assemblages collected from the ritual and civic-ceremonial context of the Southern Platform has also helped in better understanding the complex relationship between food, ideology, and the ritual. In all societies, the use and function of animals goes beyond simply their economic and caloric importance.

Some also accumulate symbolic and ritual value, and are served during festivals, feasts, or used as offerings and sacrifices. Such practices serve to reinforce and maintain social differentiation, legitimizing those with positions of power.

The abundance of camelid remains on the Southern Platform may indicate that they were often served during ceremonial activities held there. The association of camelid remains with burials at the Gallinazo Group site and other sites in the region further indicates the symbolic importance of these animals and their close ties to the ritual world. The presence of deer and abundance of sea lion on the Platform, both of which are represented in ritual scenes in Moche iconography suggests that they may have held similar ritual value at this site. It seems, then, that state-emergence in the Virú Valley was associated with the exploitation of diverse ecological niches and the manipulation of the environment to increase food surplus and food security. Increased food security would have created a food surplus, inciting an increase in population. A centralized power would have developed as a response to an increasing need to control and distribute certain resources. Certain animals and foods acquired their own symbolic value due to their scarcity and/or their association with rituals, ceremonies and feasts. These events and occasions would have likely been organized by important political and priestly figures, and were held on the Southern Platform of Huaca Gallinazo.

5.3 Future Research

Further research is needed as questions remain about the precise function of Architectural Compound 2 and the social standing of its occupants. Further archaeological investigation at Architectural Compound 2 could reveal whether it is in fact a domestic

structure, which could help in interpreting the differences in patterns of consumption observed at Architectural Compound 2 and the Southern Platform. Further excavation in both areas would also result in larger, more representative samples, clarifying whether some of the trends observed here (for example the paucity of femora) were simply the result of sampling error. Future excavation at the site may reveal other residences, some attributed to higher and lower social classes, which would allow a broader investigation of differential access to resources according to social ranking. Furthermore, further excavations at the site could help better explore just how much inequality may have existed at the site, and the reasons behind this inequality and social differentiation. Evidence of sharp social inequality in ancient and modern societies have been explained through models that emphasize internal conflict (Webster 1975). Societies where social differentiation does not seem quite as stark have often been described as a society where collective enterprise was emphasized (Blanton *et al.* 2008).

Other interesting lines of inquiry for future research would be exploration of the ceremonial role of deer, the use of dogs, and the potential impact of El Niño events on the Early Intermediate Period occupants of the Virú valley. Further excavation could reveal if, indeed, deer are only associated with ritual contexts. Additionally, a bigger deer sample might permit a study of seasonal hunting patterns to determine at what time of year they were hunted. It is also possible that domesticated deer were kept at or near sites for the purpose of being released and killed during important ritual hunts as was the case at the Preclassic Mayan site of Colha, Belize (White *et al.* 2000). Isotopic analysis of deer bones would indicate whether the deer from Gallinazo Group site were eating maize. A significant proportion of maize in their diet would suggest that they were held in

captivity, likely for ritual purposes. Similarly, further excavation and a bigger sample of dog bones could help us determine whether dogs were kept as companions, food, or both. Moche iconography suggests they served as hunting companions. A single cutmark on a dog bone from the Gallinazo Group suggests that they may also have been eaten. Because dogs are often fed household scraps, isotopic analysis of their bones could provide a very useful proxy indicator of human diets at the site. Finally, future palaeo-environmental investigation in the region could also examine whether the occupants of the Gallinazo Group site were affected by El Niño events. If so, they likely affected diet and subsistence at the site, processes which could be investigated through future zooarchaeological research.

This study has provided some preliminary insights into faunal consumption practices during the development of the Virú polity, but a fuller appreciation of the diversity of these practices across space and through time requires additional assemblages for comparison.

References Cited

Adams, R. L.

2004 An ethnoarchaeological study of feasting in Sulawesi, Indonesia. *Journal of Anthropological Archaeology* 23: 56-78.

Altamirana Enciso, A. J.

1983 Guia Osteologica de Cervidos Andinos. Lima: Universidad Nacional Mayor San Marcos, Departamento Academico de Ciencias Historico-Sociales, Gabinete de Arqueologia Colegio Real. Serie Investigaciones N. 6.

Arkush, E., C. Stanish

2005 Interpreting Conflict in the Ancient Andes: Implications for the Archaeology of Warfare. *Current Anthropology* 46(1):3-28.

Arnold, D.E.

1988 Matrilineal practice in a Patrilineal Setting: ritual and Metaphors of Kinship in an Andean Ayllu. Unpublished Ph.D. Dissertation. University College London.

1993 *Ecology and Ceramic Production in an Andean Community*. Cambridge: Cambridge University Press.

Ashmead, A.S.

1903 Testimony of the Huacos (Mummy-Grave) potteries of Old Peru. *Proceedings of the American Philosophical Society* (42): 387-396.

Armas, Jose.

1996 Los talleres alfareros. In *Informe Tecnico Financiero 1995*, 98-113. Edited by Santiago Uceda and Ricardo Morales. Manuscript on file. Proyecto

Arqueologico Huaca de la Luna. Facultad de Ciencias Sociales, Universidad Nacional de la Libertad, Trujillo.

Bauer, B.S. and R. A. Covey

2002 Processes of State Formation in the Inca Heartland (Cuzco, Peru). *American Anthropologist* 104(3): 846-864.

Bawden, G.

1996 *The Moche*. Blackwell, Cambridge.

Bennett, Wendell C.

1950 The Gallinazo Group, Virú Valley, Peru. New Haven: Yale University Press.

Benson, E.P.

2012 *The Worlds of the Moche on the North Coast of Peru*. University of Texas Press.

Billman, B.R.

2002 Irrigation and the Origins of the Southern Moche State on the North Coast of Peru. *Latin American Antiquity* 13(4): 371-400

Binford, L.R.

1978 *Nunamiut Ethnoarchaeology*. Academic Press, New York.

1984 *Faunal Remains from Klasies River Mouth: Monograph*. Academic Press, New York.

Blanton, R.E.

1996 Dual-Processual Theory for the Evolution of Mesoamerican Civilization. *Current Anthropology* 37(1): 1-14

Blanton, R.E. and L.F. Fargher

2008 *Collective Action in the Formation of Pre-Modern State*. In Feinman, Price, eds, *Fundamental Issues in Archaeology*, Springer: New York.

Boserup, E.

1965 *The Conditions of Agricultural Growth: the Economics of Agrarian Change under Population Pressure*. Chicago: Aldine.

Bourget, S.

2001 *Rituals of Sacrifice: Its practice at Huaca de la Luna and its representation in Moche iconography*. In Pillbury, ed., *Moche Art and Archaeology in Ancient Peru*, 89-109. New Haven: Yale and University Press.

2006 *Sex, Death, and Sacrifice in Moche Religion and Visual Culture*. University of Texas Press: Texas.

Bourget, S., K.L. Jones

2008 *Iconography Meets Archaeology*, In Bourget, S., K.L Jones (eds.), *The Art and Archaeology of the Moche*, 1-22, Texas: University of Texas Press.

Borella, F., Vales, D.G., Goodall, N.P., and E. A. Crespo.

2013 Esquema Preliminar de Fusion Epifisaria en Huesos de Lobos Marinos (*Arctocephalus Australis* y *Otaria Flavescens*), su contribución en los análisis zooarqueológicos.

Boyd, C.C. and D.C. Boyd.

1991 A Multidimensional Investigation of Biocultural Relationships among Three Late Prehistoric Societies in Tennessee. *American Antiquity* 56: 75-88.

Brennan, Curtiss T.

1980 Cerro Arena: Cultural Complexit and Nucleation in North Coastal Peru. *Journal of Field Archaeology* 7(1): 1-22.

1982 Cerro Arena: Origins of the Urban Tradition on the Peruvian north coast. *Current Anthropolology* 23(3):247-254.

Brewster-Wray, C.

1990 *Moradchayuy: An Administrative Compound at the Site of Huari, Peru*. Ph.D. dissertation, State University of New York, Binghamton. University of Microfilms, Ann Arbor.

Browman, D.L.

1974 Pastoral nomadism in the Andes. *Current Anthropology* 15(2): 188-196.

Burger, R.L.

1992 *Chavin and the Origins of Andean Civilization*. New York: Thames and Hudson.

Camino, A., Johns, T.

- 1988 Laki-laki (*Dennstaedtia glauca*, Polypodiaceae): a green manure used in traditional Andean agriculture. *Economic Botany* 42: 45-53.

Carden, R.F., and T.J. Hayden

- 2006 Epiphyseal fusion in the postcranial skeleton as an indicator of age at death of European fallow deer (*Dama dama*, Linnaeus, 1758).

Carod-Artal, F.J. and C.B. Vázquez-Cabrera.

- 2007 Sacred Psychoactive Seeds and Ritual Sacrifices in the Moche Culture. *Revista de Neurología* 44(1): 43-50.

Chapdelaine, C.

- 2001 *The growing power of a Moche urban class*. In Pillsbury, J. (ed.), *Moche Art and Archaeology in Ancient Peru*, National Gallery of Art, Washington, DC, pp. 69-87.

- 2002 *Out in the streets of Moche: urbanism and socio-political organization at a Moche IV urban center*. In Isbell, W. H., and Silverman, H. (eds.), *Advances in Andean Archaeology and Ethnohistory*, Plenum Press, New York, pp. 53-88.

Chávez, K.L.M.

- 1984-1985 Traditional Pottery of Raqch'i, Cuzco, Peru: a preliminary study of its production, distribution, and consumption. *Ñawpa Pacha*: 22-23.

Chicoine, D.

- 2006 Early Horizon Architecture at Huambacho, Nepeña Valley, Peru. *Journal of Field Archaeology* 31(2): 1-22

- 2010 Elite Strategies and Ritual Settings in Coastal Peru during the 1st Millennium BC. In *Comparative Perspectives in Coastal South America*, R. Cutright, E. Lopez-Hurtado, and A. Martin (eds.), pp. 191-212. Center for Comparative Archaeology, University of Pittsburgh, Fondo Editorial PUCP, Ministerio de Cultura del Ecuador, Pittsburgh, Lima, and Quito.

- 2011 Feasting Landscapes and Political Economy at the Early Horizon Center of Huambacho of the Nepeña Valley, Peru. *Journal of Anthropological Archaeology* 30(3): 432-453.

- 2012 Marine Exploitation and Paleoenvironment as Viewed through Molluscan Resources at the Early Horizon Center of Huambacho, Nepeña Valley, Coastal Ancash. *Andean Past* (10): 284-290.

Cieza de León, P.d.

1964 The Travels of Pedro de Cieza de León: A.D. 1532-50 contained in the first part of his Chronicle of Peru. Franklin, New York.

Claessens, L., Edwards, S., Mentzer, T., Murphy, D., and C. Sullivan. (2012, July 21) Aves 3D: A Three Dimensional Database of Avian Skeletal Morphology.
http://aves3d.org/species_instances/131-Spheniscus-humboldti

Cohen, A. and D. Serjeantson.

1996 *A Manual for the Identification of Bird Bones from Archaeological Sites*. Revised Edition. London: Archetype Publications Ltd.

Crabtree, P.J.

1990 Zooarchaeology and Complex Societies: Some Uses of Faunal Analysis for the Study of Trade, Social Status, and Ethnicity. *Archaeological Method and Theory* 2: 155-205.

Cushing, D.H.

1982 *Climate and fisheries*. London: Academic Press.

Davis, S.J.M.

1987 *The Archaeology of Animals*. Yale University Press, New Haven and London, 224 pp.

deFrance, S.

1996 Iberian Foodways in the Moquegua and Torata Valleys of Southern Peru. *Historical Archaeology* 30(3): 20-40.

2009 Zooarchaeology in Complex Societies: Political Economy, Status, and Ideology. *Journal of Archaeological Research* 17: 105-168.

Dietler, M., and Hayden, B.

2001 *Feasts: Archaeological and Ethnographic Perspectives on Food, Politics, and Power*. Alabama: University of Alabama Press.

Dobkin de Rios, M.

1977 Plant hallucinogens and the religion of the Mochica- an ancient Peruvian people. *Economy Botany* 31(2): 189-203.

Donnan C.B. and C.J. Mackey.

1978 *Ancient Burial Patterns of the Moche Valley, Peru*. Austin: University of Texas Press.

Donnan, C.B. and D. McClelland.

1979 *The Burial Theme in Moche Iconography*. In: *Studies in Pre-Columbian Art and Archaeology* (21), Harvard University: Washington, D.C.

Fiedler, R.H.

1934 *Fishery Industries of the United States*. U.S. Government Printing Office, 1935.

Flannery, K.V., Marcus, J., and R.G. Reynolds.

1989 *The Flocks of Wamani: a Study of the Llama Herders on the Punas of Ayacucho, Peru*. Academic Press, San Diego.

Franklin, W.L.

1982 Biology, ecology, and relationship to man of the South American Camelids. In *Mammalian biology in South America*, M.A. Mares and H.H. Genoways (eds.), pp. 457-489. Pittsburg: University of Pittsburg.

Ford, James A.

1949 Cultural Dating of Prehistoric Sites in Virú Valley, Peru. *Anthropological Papers of the American Museum of Natural History* 43:31-78.

Furst, P.T.

1974 *Hallucinogens in Precolumbian art*. In M.E. King and I.R. Traylor (eds.), *Art and environment in native america*, pp. 50-101, Museum of Texas Technological University: Lubbock, Texas.

Garcilaso de la Vega, I.

1966 *Royal Commentaries of the Incas and the General History of Peru*. Austin: University of Texas Press.

1987 *Royal Commentaries of the Incas and the general history of Peru*. H.V. Livermore (ed.), Austin: University of Texas Press, p. 232.

Goldstein, P.S.

1993 House, Community, and State in the Earliest Tiwanaku Colony: Domestic Patterns and State Integration at Omo M12, Moquegua. In, M. Aldenderfer

(ed), *Domestic Architecture, Ethnicity, and Complementarity in the South-Central Andes*, pp.25-41. University of Iowa Press.

Grayson, D.K.

1979 On the quantification of archaeofaunas. *Advances in Archaeological Method and Theory* 2: 199-237.

1984 *Quantitative zooarchaeology*. Academic Press: New York.

Haas, J.

1987 *The exercise of power in early Andean state development*. In, Haas, J. Pozorski S., Pozorski T. (eds), *The Origins and Development of the Andean State*. New York: Cambridge University Press.

Hassan, Fekri A.

1978 Demographic Archaeology. *Advances in Archaeological Method and Theory* (1): 49-103.

Hastorf, C.

1993 Pre-hispanic Political Change and the Role of Maize in the Central Andes of Peru. *American Anthropologist* 95(1):115-138.

Haviland, William A.

1970 Tikal, Guatemala and Mesoamerican Urbanism. *World Archaeology* 2(2): 186-198.

Hayden, B.

1996 *Feasting in prehistoric and traditional societies*. In: Wiessner, P. and W. Schiefenhövel (eds), *Food and the Status Quest: An Interdisciplinary Perspective*. Providence, RI: Berghahn, pp. 127-47).

Hinderer, S., Engelhardt, W.v.

1975 Urea metabolism in the llama. *Comparative Biochemistry and Physiology A Comparative Physiology* 52: 619-622.

Horkheimer, H.

1973 *Alimentación y obtención de alimentos en el Perú prehispánico*. Universidad Nacional de San Marcos, Lima.

Ikehara, H.C., Fiorella Paipay, J., and K. Shibata.

2013 Feasting with *Zea Mays* in the Middle and Late Formative North Coast of Peru. *Latin American Antiquity* 24(2): 217-231.

Isbell, W.H.

1997 *Reconstructing Huari: a cultural chronology from the capital city*. In, Manzanilla (ed), *Emergence and Change in Early Urban Societies*, pp. 181-227, Plenum Publishers: New York and London.

Jackson, M.A.

2008 *Moche art and visual culture in ancient Peru*. University of New Mexico Press.

Kasper, J.C.

1980 Skeletal Identification of California Sea Lions and Harbour Seals for Archaeologists. San Diego, California: San Diego Museum of Man, Ethnic Technology Notes (17).

Kent, J.D.

1982 *The Domestication and exploitation of South American camelids: Methods of analysis and their application to circum-lacustrine archaeological sites in Bolivia and Peru*. PhD. Dissertation: Washington University.

Kent, J.D. and M. Kowta.

1994 The Cemetery at Tambo Viejo, Acari Valley, Peru. *Andean Past* 4: 109-140.

Kirch, P.V.

1984 *The Evolution of the Polynesian Chieftdoms*. New York: Cambridge University Press.

Kubler, G.

1948 Towards absolute time: Guano archaeology. *Memoirs of the Society for American Archaeology* (4): 29-50.

Larco Hoyle, Rafael

1938 Los mochicas. Lima,: Casa editora "La Crónica" y "Variedades".

1945 La cultura Virú. Buenos Aires: Sociedad geográfica americana.

Marcus J. and K. V. Flannery

1996 *Zapotec Civilization: How urban society evolved in Mexico's Oaxaca Valley*. Thames and Hudson, London.

Masur, Lindi.

2012 Peanuts and Prestige on the Peruvian north coast: The Archaeology of Peanuts at Huaca Gallinazo (V-59) and Huaca Santa Clara (V-67), The University of British Columbia, Vancouver, 2012.

Mengoni-Göñalons, G.

1988 Análisis de materiales faunísticos de sitios arqueológicos. *Xama* 1:71-120

2008 Camelids in ancient Andean societies: A review of the zooarchaeological evidence.

Millaire, Jean-François

2008 *Moche Textile Production on the Peruvian north coast: A Contextual Analysis*. In Bourget, S., Jones, K.L. (eds.), *The Art and Archaeology of the Moche: An Ancient Society of the Peruvian north coast*, 229-245. University of Texas Press, Austin.

2010 Primary State Formation in the Virú Valley, North Coast of Peru. *Proceedings of the National Academy of Sciences* 107(14):6186-6191.

2012 Recent Radiocarbon Dating in the Virú Valley, Peru. In: *Times of Change, Changes of Time: An Inquiry about Absolute and Relative Chronologies of the Moche from Northern Peru*, L. J. Castillo and C. Chapdelaine (eds.).

Millaire, Jean-François, and Edward Eastaugh

2011 Ancient Urban Morphology in the Virú Valley, Peru: Remote Sensing Work at the Gallinazo Group (100 B.C.- A.D. 700). *Journal of Field Archaeology* 36(4): 289-297

Millaire, Jean-François, and La Torre Calvera, Estuardo

2009 Proyecto Arqueológico Virú, Temporada 2009. Informe Final Presentado a la Comisión Nacional Técnica de Arqueología del Ministerio de Cultura. Lima, December 2009.

2011 Proyecto Arqueologico Virú, Temporada 2011. Informe Final Presentado a la Comision Nacional Tecnica de Arqueologia del Ministerio de Cultura. Lima, December 2011.

Millaire, Jean-François, and Magali Morlion

2009 *Gallinazo : an early cultural tradition on the Peruvian north coast*. Los Angeles: Cotsen Institute of Archaeology Press.

Miller, G.R., Burger, R.L.

1995 Our Father the Cayman, Our Dinner the Llama: Animal Utilization at Chavin de Huantar, Peru. *American Antiquity* 60(3): 421-458.

Moffitt, S.A.

1998 Aging bison by the incremental cementum growth layers in teeth. *Journal of Wildlife Management* 62: 1276-1280.

Morris, C.

1988 *Progress and Prospect in the Archaeology of the Inca*. In *Peruvian Prehistory: an Overview of Pre-Inca and Inca Society*, R.W. Keating (edt.). pp. 233-256. Cambridge University Press: Cambridge.

Morris, C., and D.E. Thompson.

1985 *Huánuco Pampa: An Inca City and Its Hinterland*. Thames and Hudson, London.

Monks, G.G.

1981. *Seasonality Studies*. In: *Advances in Archaeological Method and Theory*, vol. 4, Michael B. Schiffer, ed.: 177-240. Academic Press, New York.

Moseley, Michael E.

1992 *The Incas and Their Ancestors: The Archaeology of Peru*. Thames and Hudson, London.

Murphy, Robert C. and Jacques, Frances L.

1936 *Oceanic Birds of South America: a study of species of the related coasts and seas including the American quadrant of Antarctica, based upon the Brewster- Sanford collection in the American Museum of Natural History*. American Museum of Natural History Library: New York, Macmillan Co.

Murra, J.

1980 *The Economic Organization of the Inca State*. JAI Press, Greenwich.

Nowak, R. and Paradiso, J.

1983 *Walker's Mammals of the World*. Baltimore: John Hopkins University Press.

Orlove, B.S.

1977 *Alpacas, sheep and men: the wool export economy and regional society in Southern Peru*. London, Academic Press.

Pacheco Torrest, V.R., Altimirano Enciso, A.J., and E. S. Guerra Porras.

1979 *Guia Osteologica de Camelidos Sudamericanos*. Lima, Universidad Nacional Mayor de San Marcos: Gabinete de Arqueologia Colegio Real. Serie Investigaciones No. 4.

Pauketat, T.R., Lucretia, K.S., Fritz, J., Lopinot, N.H., Elias, S., and E. Hargrave.

2002 The Residues of Feasting and Public Ritual and Early Cahokia. *American Antiquity* 67(2): 257-279.

Payne, S.

1973 Kill-Off Patterns in Sheep and Goats: The Mandibles from Asvan Kal. *Anatolian Studies* 23: 281-303.

Payne, S. and P.J. Munson.

1985 "Ruby and how many squirrels?" *The destruction of bones by dogs*. In: N. Fieller, D. Gilbertson, and N. Ralph (eds). *Paleobiological Investigations. Research designs, methods and data analysis. British Archaeological Reports, International Series* 266. Oxford.

Pozorski, S. G.

1979 Prehistoric Diet and Subsistence of the Moche Valley, Peru. *World Archaeology* 11 (2): 163-184

Pozorski S.G., and T. Pozorski.

1979 An Early Subsistence Exchange System in the Moche Valley, Peru. *Journal of Field Archaeology* 6(4): 413-432.

2002 *Late Coastal Andean Formative*. In P. N. Peregrine and M. Ember (eds.), *Encyclopedia of prehistory* (South America, Vol. 7, pp. 217-227). New York: Kluwer Academic.

Prieto, G. O.

2010 Characterizing ritual activities in an early fishing village of the Peruvian North Coast. Paper presented to the 29th Northeast Conference on Andean Archaeology and Ethnohistory. Drew University, Madison, N.J. Saturday, October 23rd, 2010.

Quilter, J.

2001 Pillsbury, J (ed.), in *Moche Art and Archaeology in Ancient Peru*. National Gallery of Art and Yale, University Press, Washington, D.C., pp. 21-45.

Randall, J.E.

1968 *Caribbean Reef Fishes*. T.F.H. Publications, Inc. Jersey City.

Reitz, E.J.

1988 Faunal Remains from Paloma, an Archaic site in Peru. *American Anthropologist* 90: 310-322.

Ringrose, T.J.

1993 Bone Counts and Statistics: A Critique. *Journal of Archaeological Science* 20: 121-157

Roselló, E., Vásquez, V., Morales, A., and T. Rosales.

2001 Marine Resources from an Urban Moche (470-600 A.D.) area in the 'Huacas del Sol y de la Luna' Archaeological Complex (Trujillo, Peru). *International Journal of Osteoarchaeology* 11(1-2): 72-87.

Sandweiss, D.H.

1979 Mollusk and Man in Prehistoric Peru: Preliminary Studies. *B.A. Dissertation*, Yale University, New Haven.

Sandweiss, D.H. and E.S. Swing.

1997 Ritual Rodents: The Guinea Pigs of Chinch, Peru. *Journal of Field Archaeology* 24(1): 47-58.

Shimada, I.

1994 *Pampa Grande and the Mochica Culture*. University of Texas Press.

Shimada, I., and M. Shimada

1985 Prehistoric Llama Breeding and Herding on the North Coast of Peru. *American Antiquity* 50(1): 3-26.

Schweigger, E.

1964 *El Litoral Peruano*. Universidad Nacional 'Federico Villarreal', Lima, Peru: 414pp.

Silver, A.

1969 *The Aging of Domestic Animals*. In D. Brothwell and E.S. Higgs eds. *Science in Archaeology* (2nd ed): London. Pp. 283-302.

Smith, Charles T.

1960 Aspects of Agriculture and Settlement in Peru. *The Geographic Journal* 126(4): 397-409.

Spencer, C.S.

1993 Human Agency, Biased Transmission, and the Cultural Evolution of Chiefly Authority. *Journal of Anthropological Archaeology* 12(1): 41-74.

Spencer, C.S., E.M. Redmond

2001 Multilevel Selection and Political Evolution in the Valley of Oaxaca, 500-100 B.C. *Journal of Anthropological Archaeology* 20:195-229.

Stanish, C.

2000 Negotiating Rank in an Imperial State: Lake Titicaca Basin Elite Under Inca and Spanish Control. In, M. Diel (ed), *Hierarchies in Action*. Southern Illinois University Center for Archaeological Investigations, Occasional Paper 27. Carbondale: Southern Illinois University Center for Archaeological Investigations.

Strong, W.D., and C. Evans.

1952 *Cultural Stratigraphy in the Virú Valley, Northern Peru: The Formative and Florescent Epochs*. Volume 4. New York: Columbia University Press.

Surette, F., Szpak, P., White, C.D., Longstaffe, F.J., and J-F Millaire.

2010 Stable Isotope, Contextual and Functional Analysis of Early Intermediate Textile from the Virú Valley (Northern Peru). Presented at the Society of American Archaeology 75th Annual Meeting, St. Louis, Missouri, April 13-18th.

Szpak, P.

2011 Fish bone chemistry and ultrastructure: implicatons for taphonomy and stable isotope analysis. *Journal of Archaeological Science* 38: 3358-3372.

2013 Stable Isotope Ecology and Human-Animal Interactions in the Northern Peru. Unpublished Ph.D. Dissertation. London, Ontario: University of Western Ontario.

Szpak, P., Millaire, J-F., White, C.D., and F. Longstaffe

2012 Influence of seabird guano and camelid dung fertilization on the nitrogen isotopic composition of field-grown maize (*Zea mays*). *Journal of Archaeological Science* 39: 3721-3740

Szpak, P., White, C.D., Millaire, J-F, and F.J. Longstaffe

2010 Isotopic Evidence for Traded Fabrics and Camelid Management Practices in Northern Peru (Early Intermediate Period). Poster presented at: 38th Midwest Conference on Andean and Amazonian Archaeology and Ethnohistory; Feb 2010; Indiana University-Purdue University, Fort Wayne, Indiana.

Uceda, S.

2001 Investigations at Huaca de la Luna, Moche Valley: An example of Moche religious architecture. In, eds., Pillbury, *Moche Art and Archaeology in Ancient Peru*, 47-68. New Haven: Yale University Press.

Uceda, S., Mujica, E., and R. Morales.

1996 *Investigaciones en la Huaca de la Luna, 1996*. Proyecto Arqueologico: Huacas del Sol y de la Luna. Facultad de Ciencias Sociales: Universidad de Trujillo.

1997 *Investigaciones en la Huaca de la Luna, 1997*. Proyecto Arqueologico: Huacas del Sol y de la Luna. Facultad de Ciencias Sociales: Universidad de Trujillo.

1998-1999 *Investigaciones en la Huaca de la Luna, 1998-1999*. Proyecto Arqueologico: Huacas del Sol y de la Luna. Facultad de Ciencias Sociales: Universidad de Trujillo.

2000 *Informe Tecnico 2000*. Proyecto Arqueologico: Huacas del Sol y de la Luna. Facultad de Ciencias Sociales: Universidad de Trujillo.

2003 *Informe Tecnico 2003*. Proyecto Arqueologico: Huacas del Sol y de la Luna. Facultad de Ciencias Sociales: Universidad de Trujillo.

van Gijseghem, H.

2001 Household and Family at Moche, Peru: An Analysis of Building and Residence Patterns in a Prehispanic Urban Center. *Latin American Antiquity* 12(3): 257-373.

Van Derwarker, A.M.

1999 Feasting and Status at the Toqua Site. *Southeastern Archaeology* 18: 24-34.

Vásquez Sánchez, V. F., Rosales, T., Morales, A., and E. Roselló

2003 Zooarqueología en la zona urbana Moche, complejo Huacas del Sol y de la Luna, Valle de Moche. Pontificia Universidad Católica del Perú.

Vaz-Ferreira, R.

1981 South American Sea Lions (*Otaria flavescens*, Shaw, 1800). In: *Handbook of Marine Mammals*, Vol. 1. The Walrus, Sealions, Fur Seals and Sea Otters (eds. Ridgeway, S. H. & Harrison R. J.). Academic Press: London, New York, Toronto, Sydney, San Francisco: 39-65.

Verano, J.W.

2001 The Physical Evidence of Human Sacrifice in Ancient Peru. In Benson and Cook (eds.), *Ritual Sacrifice in Ancient Peru*, 165-184. Austin: University of Texas Press.

Verano, J.W., DeNiro, M.J.

1993 *Local or foreigners? Morphological, biometric and isotopic approaches to the question of group affinity in human skeletal remains recovered from unusual archaeological context.* In: Sanford, M.K. (ed.), *Investigations of Ancient Human tissue: Chemical Analysis in Anthropology*. Gordon and Breach, Langhorne: 361-386.

Weimerskirch, H., Silva J., Bost C.A., and S. Peraltilla.

2012 Foraging in Guanay cormorant and Peruvian booby, the major guano-producing seabirds in the Humboldt Current System. *Marine Ecology Progress Series* (458): 231-245

Weinstock, J.

2009 Epiphyseal fusion in brown bears: a population study of grizzlies (*Ursus arctos horribilis*) from Montana and Wyoming. *International Journal of Osteoarchaeology* 19 (3): 416-423.

Wheeler, J. C.

- 1982 Ageing llamas and alpacas by their teeth. *Llama World* (1): 12-17.

White, C.D., Pohl, Mary E.D., Schawrcz, H.P., and Fred J. Longstaffe

- 2001 Isotopic Evidence for Maya Patterns of Deer and Dog Use at Preclassic Colha.

Willey, Gordon R.

- 1953 Prehistoric Settlement Patterns in the Virú Valley, Perú. Washington, D.C.: United States Government Printing Office.

Wilson, D.J.

- 1981 Of Maize and Men: A Critique of the Maritime Hypothesis of State Origins on the Coast of Peru. *American Anthropologist* 83:93-120.
- 1983 The Origins and Development of Complex Prehispanic Society in the Lower Santa Valley, Peru: Implications for Theories of State Origins. *Journal of Anthropological Archaeology* 2:209-276.

Wright, H.T.

- 1977 Recent Research on the Origins of the State. *Annual Review of Anthropology* 6:379-397.

Yamamoto, N.

- 1985 The ecological complementarity of agro-pastoralism: some comments. In: Masuda, S., Shimada, I., Morris C. (Eds.), *Andean Ecology and Civilization: An Interdisciplinary Perspective on Andean Ecological Complementarity*. Tokyo: University of Tokyo Press, pp. 85-99.

Appendices

Appendix A: Bon Recording Zones by Element

Zones for the Cranium

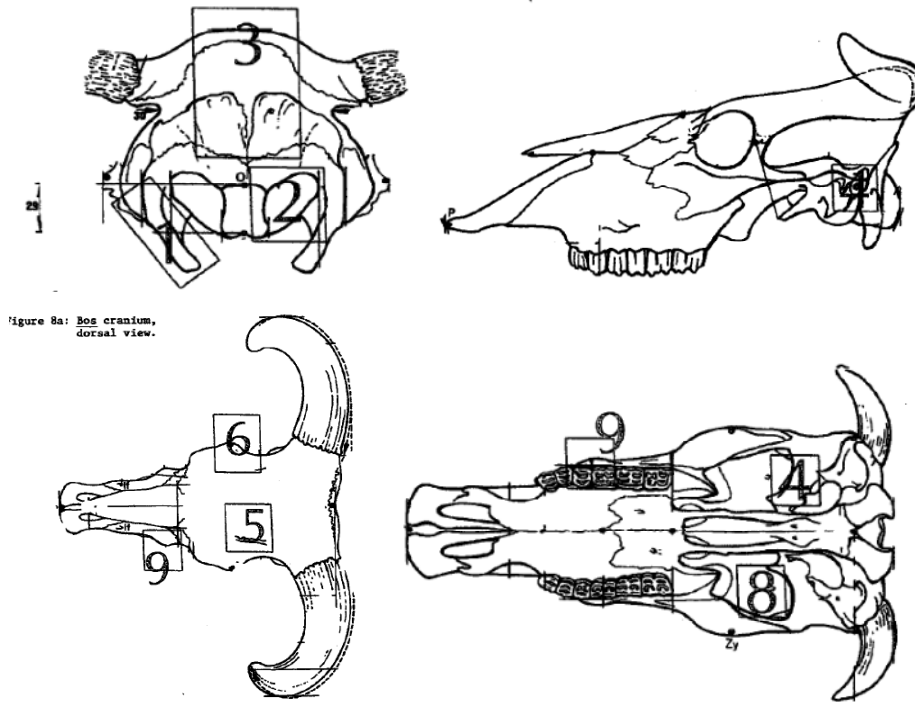

Zones for the Mandible

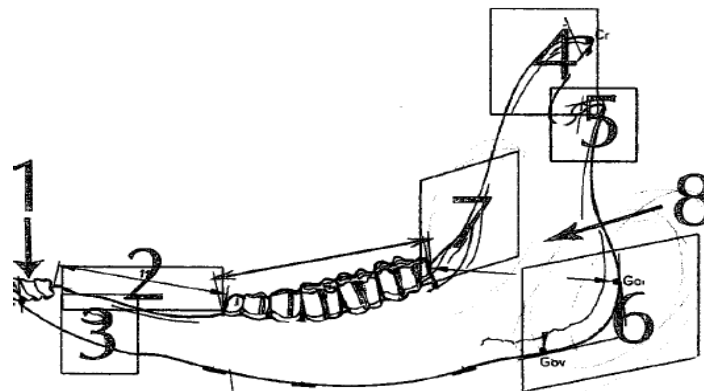

Zones for the Scapula

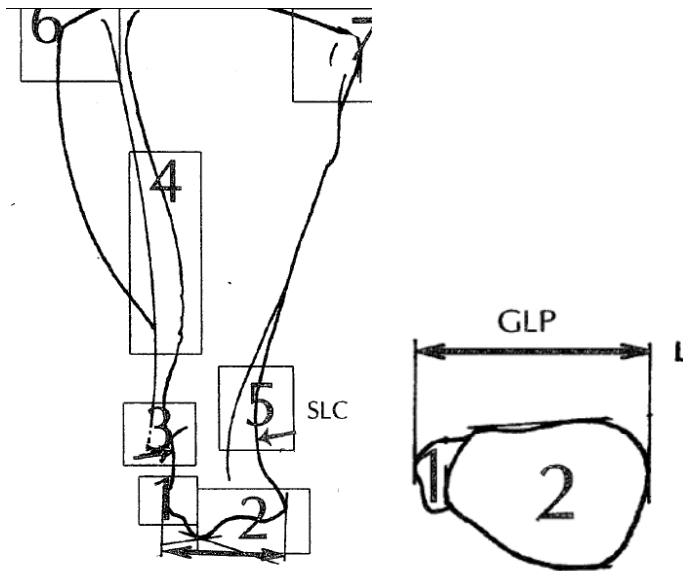

Zones for the Humerus

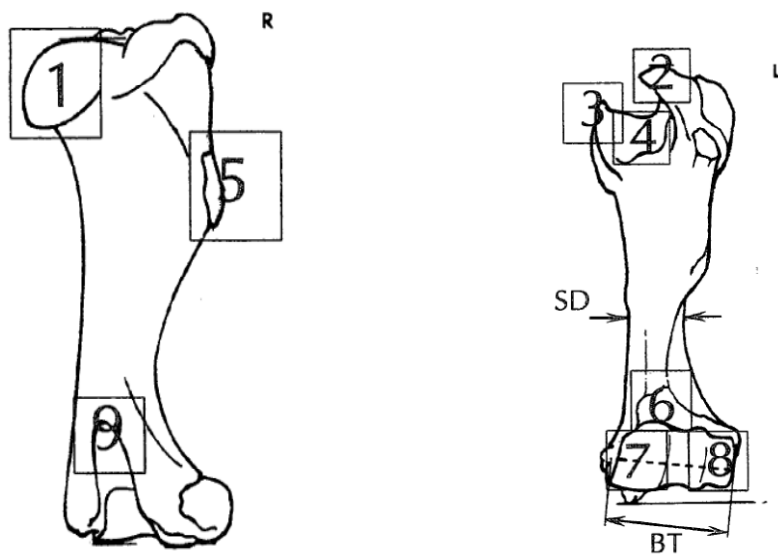

Zones for the Radius

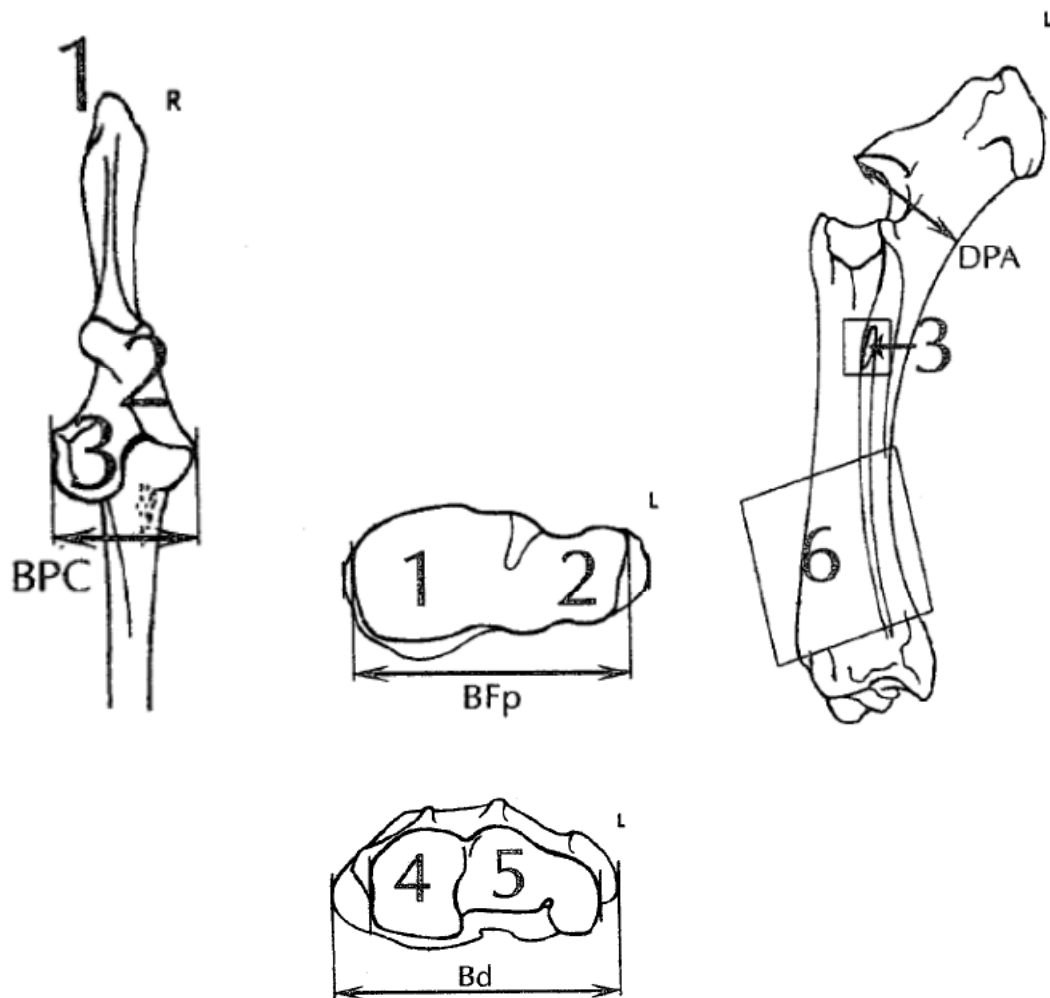

Zones for the Pelvis

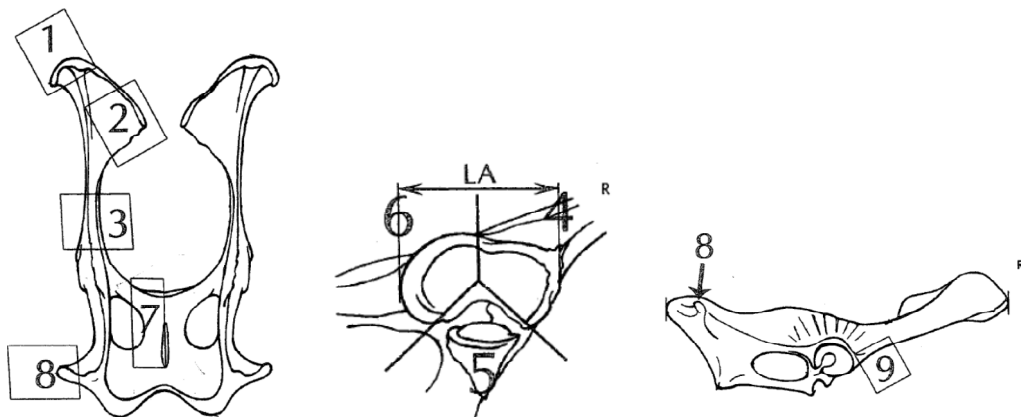

Zones for the Femur

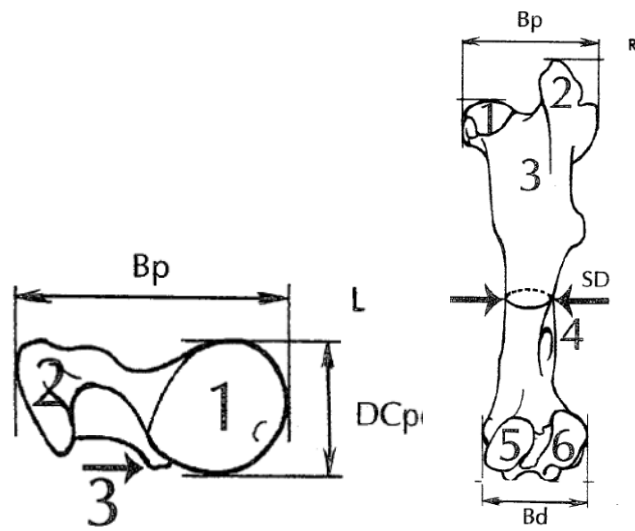

Zones for the Tibia

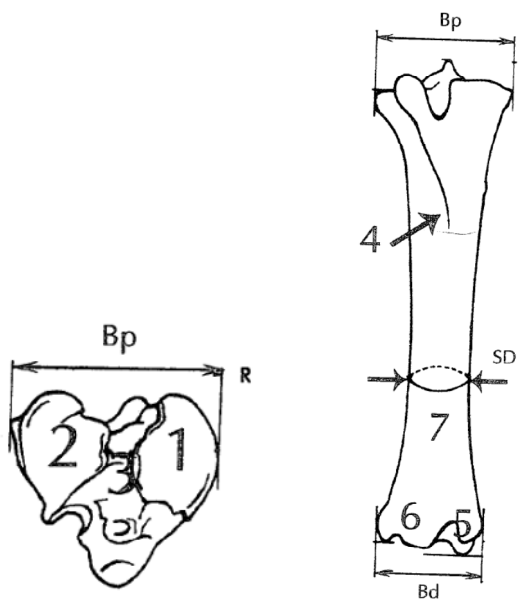

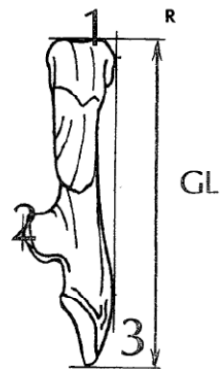
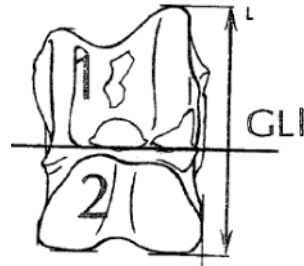
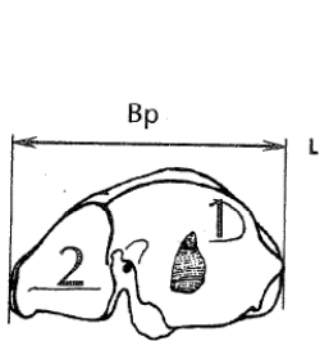
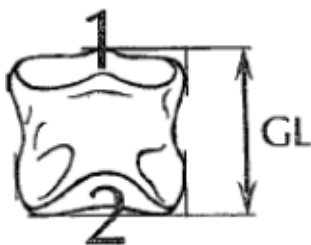
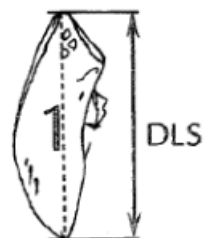
Zones for the Calcaneus**Zones for the Astragalus****Zones for Metacarpus/Metatarsus****Zones for Phalanges 1 and 2****Zone for Phalanx 3**

Curriculum Vitae

Name: Claire Venet-Rogers
Post-secondary Education and Degrees: University of Western Ontario
 London, Ontario, Canada
 2006-2011, B.A.

Honours and Awards

University of Western Ontario, Social Sciences Faculty Dean's Honour List, 2008-2009, 2009-2010, 2010-2011.

Social Science and Humanities Research Council (SSHRC) Master's Scholarship
 2012-2013

Related Work Experience

Teaching Assistant
 The University of Western Ontario
 2011-2013

Grant-Research Assistant
 The University of Western Ontario
 2011

Work-Study Position
 The University of Western Ontario, Anthropology Department, Stable Isotopes Lab Assistant
 2010-2011

Publication:

Venet-Rogers, Claire. (2012) The applications of stable isotope research in Canada's archaeological past: reconstruction of ancient diets in the northwest Pacific coast, the Canadian Prairies and southern Ontario. *Revista Arqueobios* 6(1): 66-78