Electronic Thesis and Dissertation Repository

8-23-2013 12:00 AM

Design and Development of a Novel Expanding Pedicle Screw for Use in the Osteoporotic Lumbar Spine

Parham Rasoulinejad
The University of Western Ontario

Supervisor
Dr. Chris Bailey
The University of Western Ontario

Graduate Program in Medical Biophysics
A thesis submitted in partial fulfillment of the requirements for the degree in Master of Science
© Parham Rasoulinejad 2013

Follow this and additional works at: <https://ir.lib.uwo.ca/etd>



Part of the [Biomedical Devices and Instrumentation Commons](#), and the [Orthopedics Commons](#)

Recommended Citation

Rasoulinejad, Parham, "Design and Development of a Novel Expanding Pedicle Screw for Use in the Osteoporotic Lumbar Spine" (2013). *Electronic Thesis and Dissertation Repository*. 1614.
<https://ir.lib.uwo.ca/etd/1614>

This Dissertation/Thesis is brought to you for free and open access by Scholarship@Western. It has been accepted for inclusion in Electronic Thesis and Dissertation Repository by an authorized administrator of Scholarship@Western. For more information, please contact wlsadmin@uwo.ca.

DESIGN AND DEVELOPMENT OF A NOVEL EXPANDING PEDICLE
SCREW FOR USE IN THE OSTEOPOROTIC LUMBAR SPINE

(Thesis format: Monograph)

by

Parham Rasoulinejad

Graduate Program in Medical Biophysics
Department of Medical Biophysics

A thesis submitted in partial fulfillment
of the requirements for the degree of
Master of Medical Biophysics

The School of Graduate and Postdoctoral Studies
The University of Western Ontario
London, Ontario, Canada

© Parham Rasoulinejad 2013

ABSTRACT

Pedicle screws are commonly utilized in spinal surgery; however, traditional designs often do not provide adequate fixation in osteoporotic spines. The objective of this thesis was to develop a novel expanding screw for use in osteoporotic lumbar pedicles. Helical screws capable of expanding post insertion were built on a rapid prototype machine. A materials testing machine performed axial load to failure tests in both Sawbones and cadaveric specimens comparing the new design to traditional screws (rate = 10mm/min to 20 mm). Output parameters included yield load, ultimate load, stiffness, energy to failure and total energy. The expanding screw showed a 36% increase in total energy ($p=0.02$), but no other differences were identified. Based on this initial design, the expandable pedicle screws failed to demonstrate improved screw pullout; however, differences may be observed in other loading modes (*i.e.*, toggle) and further design modifications and improvements in post-build machining may provide beneficial enhancements.

Keywords: spine, biomechanics, implant fixation, mechanical testing, pedicle screws, osteoporosis, biomechanics, pullout strength, expanding screws

CO-AUTHORSHIP STATEMENT

The research performed in this body of work was a collaborative effort between several individuals with diverse expertise. Without the full dedication and support of those involved, this project would not have been possible. Contributions are as follows:

Chapter 1: Parham Rasoulinejad – sole author

Chapter 2: Parham Rasoulinejad – implant design, study design, data collection, data analysis, wrote manuscript; Chris Bailey – implant design, study design, reviewed data analysis, reviewed manuscript; Cynthia Dunning – implant design, study design, reviewed manuscript; Fawaz Siddiqi – implant design, study design, financial support, reviewed data analysis, reviewed manuscript; Kevin Gurr – Implant design; Stewart McLachlin – implant design, study design, data collection, data analysis, reviewed manuscript; Jacob Reeves – implant design.

Chapter 3: Parham Rasoulinejad – study design, data collection, data analysis, wrote manuscript; Chris Bailey – study design, reviewed data analysis, reviewed manuscript; Cynthia Dunning – study design, reviewed manuscript; Stewart McLachlin – data collection, data analysis, reviewed manuscript.

Chapter 4/5: Parham Rasoulinejad – sole author

ACKNOWLEDGMENTS

I would like to thank my supervisors Dr. Chris Bailey and Dr. Cynthia Dunning for providing me the opportunity to join their research laboratory and for supporting me throughout the process. Their guidance allowed me to have the right balance of autonomy and support to allow me to have an excellent learning experience while completing this project. Dr. Bailey has been my educator, mentor, and friend both in the lab as well as during my clinical training as a spine surgeon and I am forever grateful.

I would also like to thank Dr. Fawaz Siddiqi for his support during this work. He believed in this project throughout the process and continues to encourage me to pursue it despite many early failures. His continued support in production and testing of the numerous devices should also be acknowledged. Dr. Siddiqi has also been my educator and mentor for the last year and I am grateful to him.

I must acknowledge the work of my lab mates: Dr. Stewart McLachlan and Mr. Jacob Reeves. Without their knowledge, skills and hard work the design and testing of this screw would not have been possible. They are both very talented engineers with bright futures ahead of them.

Finally, I would like to thank my wife for her love and support throughout my career and for encouraging me to pursue this opportunity. I am certain without her support and sacrifice I would not have had the ability to complete this project.

TABLE OF CONTENTS

Abstract	ii
Co-Authorship Statement.....	iii
Acknowledgments.....	iv
Table of Contents	v
List of Tables	vii
List of Figures	viii
Abbreviations, Symbols, and Nomenclature	x
Chapter 1: Introduction	1
1.1 The Human Spine	1
1.2 Surgical Instrumentation of the Pedicle.....	4
1.3 History of the Pedicle Screw.....	7
1.4 Implant Materials	10
1.5 Screw Design	11
1.6 Thesis Rationale.....	15
1.7 Objective and Hypothesis	15
Chapter 2: Materials and Methods.....	17
2.1 Implant Design.....	17
2.1.1 Complete Helix	18
2.1.2 Distal and Central Helix.....	19
2.1.3 Window Screw.....	19
2.2 Testing Protocol	25
2.2.1 Sawbones Testing	25
2.2.2 Cadaveric Testing	31

Chapter 3: Results	34
3.1 Sawbones Testing	34
3.2 Cadaveric Testing	35
Chapter 4: Summary and Discussion	48
Chapter 5: Future Directions and Limitations	53
References	55
Appendix A – Glossary	62
Appendix B – Supplemental Description of Helical Screw	65

LIST OF TABLES

Table 1: Cadaveric specimen demographics and bone density	32
Table 2: Ultimate failure load values for all 4 prototypes and Standard Screw	37
Table 3: Data for testing of the Standard screws in Cadaveric specimens	46
Table 4: Data for testing of the Helical screws in Cadaveric specimens	47

LIST OF FIGURES

Figure 1: The Human Spine	2
Figure 2: Lumbar Vertebra	3
Figure 3: Pedicle Screw Instrumented Fusion	5
Figure 4: Basic Screw and Thread Terminology	12
Figure 5: Design of complete helix expandable pedicle screw and the central threaded core.....	20
Figure 6: Fully Helical Expandable Screw cross section.....	21
Figure 7: Side wall angle and dimensions for helical screw.....	22
Figure 8: Modification of the complete helical screw	23
Figure 9: “Window” Srew design.....	24
Figure 10: Pedicle Preparations for Screw Insertion	27
Figure 11: X-Rays Post Screw Insertion.....	28
Figure 12: Setup for screw pullout protocol	30
Figure 13: Mean Ultimate failure load of four novel and one standard screw	36
Figure 14: Sample Load Displacement Curve	40
Figure 15: Mean ultimate failure load of standard screw vs. expandable screw	41
Figure 16: Mean energy to peak load of standard screw vs. expandable screw	42
Figure 17: Mean total energy of standard screw vs. expandable screw.....	43
Figure 18: Mean stiffness of standard screw versus the expandable screw.....	44

Figure 19: Mean yield values for the standard screw versus expandable screws 45

Figure B20: Section View of Helical Shell..... 65

Figure B21: Section View of Helical Shell and Inner Screw at Initial Ingagement 66

Figure B22: Helical Shell Expansion..... 67

Figure B23: Engineering Drawing of Novel Expanding Screw 68

ABBREVIATIONS, SYMBOLS, AND NOMENCLATURE

ANOVA – Analysis of variance

A – Anterior

ASTM – American Society for Testing and Materials

BMD – Bone mineral density

cm – Centimeter

C1 – C7 – First to seventh cervical vertebrae

C1 – Atlas, first cervical vertebra

C2 – Axis, second cervical vertebra

CT – Computed tomography

Hz – Hertz

L1 – L5 – First to fifth lumbar vertebrae

L5 – S1 – Lumbosacral joint

MRI – Magnetic Resonance Imaging

mm – Millimeter

n – Number

N – Newton

Nmm – Newton Millimeter

qCT – Quantitative computed tomography

ROM – Range of motion

SD – Standard deviation

SLM – Selective laser melting

T12 – L5 – Twelfth thoracic vertebrae to fifth lumbar vertebra

° – Degrees

α – Significance Level

% – Percentage

% Diff – Percent difference

CHAPTER 1: INTRODUCTION

OVERVIEW: This chapter provides the basic background knowledge related to spinal surgery and surgical implant use, particularly pedicle screws. Relevant information regarding spinal anatomy, surgical treatment of spinal disorders and use of spinal instrumentation is reviewed. Due to the clinical aspects of this work, the use of anatomical terms was necessary; these are defined in Appendix A.

1.1 THE HUMAN SPINE

The bony spinal anatomy is a complex structure designed to support the weight of the upper body, allow physiologic motion, and protect the spinal cord [1]. The spine is made up of vertebral bodies, which are composed of a hard outer shell of cortical bone and a spongy inner structure of cancellous bone. There are a total of 33 vertebrae in the human body: seven cervical, twelve thoracic, five lumbar, five fused sacral and three to four fused coccygeal vertebrae. Together, the vertebrae form the spinal column, which is divided into four main regions based on curvature of the column in the sagittal plane: the cervical and lumbar regions are lordotic, while the thoracic and sacral regions are kyphotic (Figure 1).

Unique anatomic variations exist between different levels of vertebra; however, excluding the very caudal and cranial ends of the spine (*i.e.*, C1/C2 and the coccyx), the rest of the spine shares many common design features. Each vertebra is composed anteriorly of the vertebral body and posteriorly of the arch, which protects the spinal cord. Projecting posteriorly from each vertebral body are two pedicles, which are made of a thick cortical tube filled with cancellous bone and serve as the only connection between the vertebral body and posterior arch (Figure 2). This anatomic structure is of particular importance for spinal surgery. The majority of modern instrumentation, including the novel devices described in this thesis, passes through the pedicle from a posterior to anterior direction to reach the vertebral body via a safe channel and utilize the strong pedicle as the main point of fixation for screw implantation.

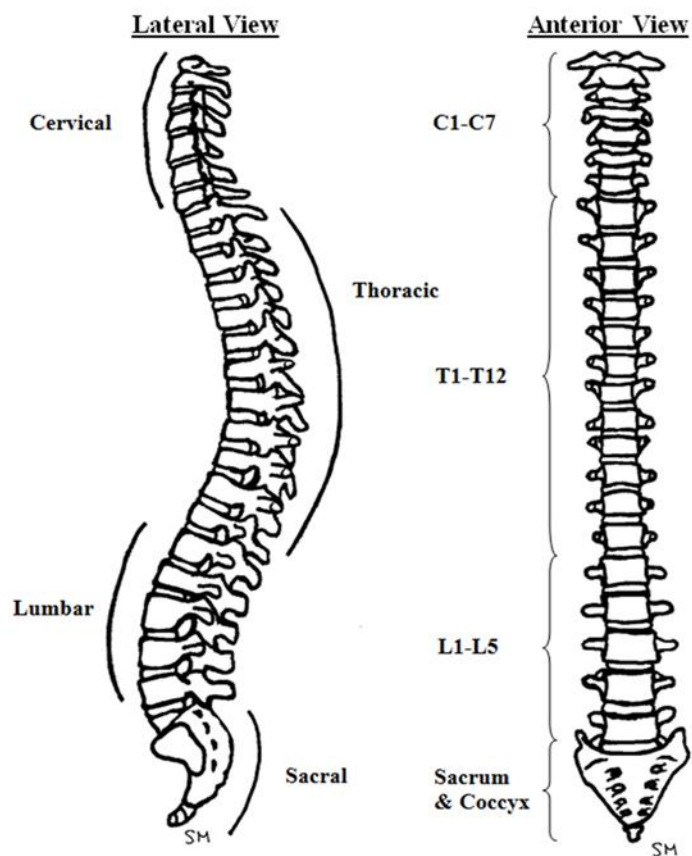

Figure 1: The Human Spine

The human spine is split into four unique regions: cervical (C1-C7), thoracic (T1-T12), lumbar (L1-L5), and sacral (sacrum and coccyx). Curvature in the cervical and lumbar spine is lordotic, while the thoracic and sacral are kyphotic.

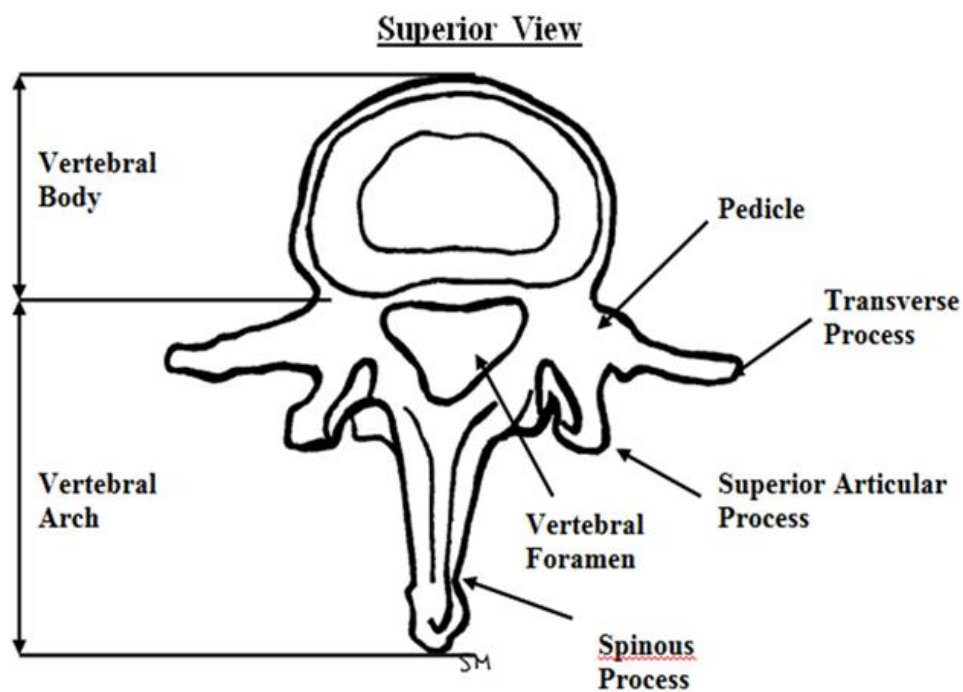

Figure 2: Lumbar Vertebra

The vertebra is split in the coronal plane into the body and the arch. The body is the large anterior mass. The arch, positioned posteriorly, is made up of the pedicles and processes, forming the spinal canal to house and protect the spinal cord. The pedicles are bony tunnels that connect the body to the arch.

Morphometry of both the thoracic and lumbar spine has been described by previous authors [2, 3]. These studies were key resources in the designing process of the novel screws described in this chapter, as well as determining the insertion angle of each screw during biomechanical testing. In brief, excluding the cervical spine, the smallest transverse pedicle diameter is found on average to be 4.5mm at T5 level, while the largest average transverse pedicle diameter is approximately 18mm at the L5 level. Furthermore, the pedicle is oval shaped with the sagittal diameter being slightly larger than the transverse diameter, although the degree of this difference is variable. This plays a major role in implant design, since the best fit can only be obtained if the instrumentation system allows the use of multiple screw sizes to accommodate variation in pedicle size. With current surgical techniques, most surgeons attempt to obtain an 80% screw-pedicle diameter fill, which is thought to be optimal and a good balance between safety and secure fixation [4].

1.2 SURGICAL INSTRUMENTATION OF THE PEDICLE

The use of pedicle screws in spinal surgery is broad and encompasses the treatment of deformity, trauma, cancer and degenerative disorders, including degenerative lumbar spine disease [5, 6]. Degenerative lumbar disease causing nerve compression is a common problem, and it responds well to surgery. The frequency of this disease is increasing due to an aging demographic. A common form of treatment is fusion and decompression of the lumbar spine with use of pedicle screws as the primary mode of stabilization (Figure 3).

Although multiple forms and types of spinal instrumentation exist, the pedicle screw is the most commonly utilized [1]. These screws are inserted from posterior to anterior (i.e. from the back to the front of the vertebral body). Screws in adjacent bodies are rigidly connected via rods to one another to achieve fusion or stabilization of adjacent vertebra (Figure 3).

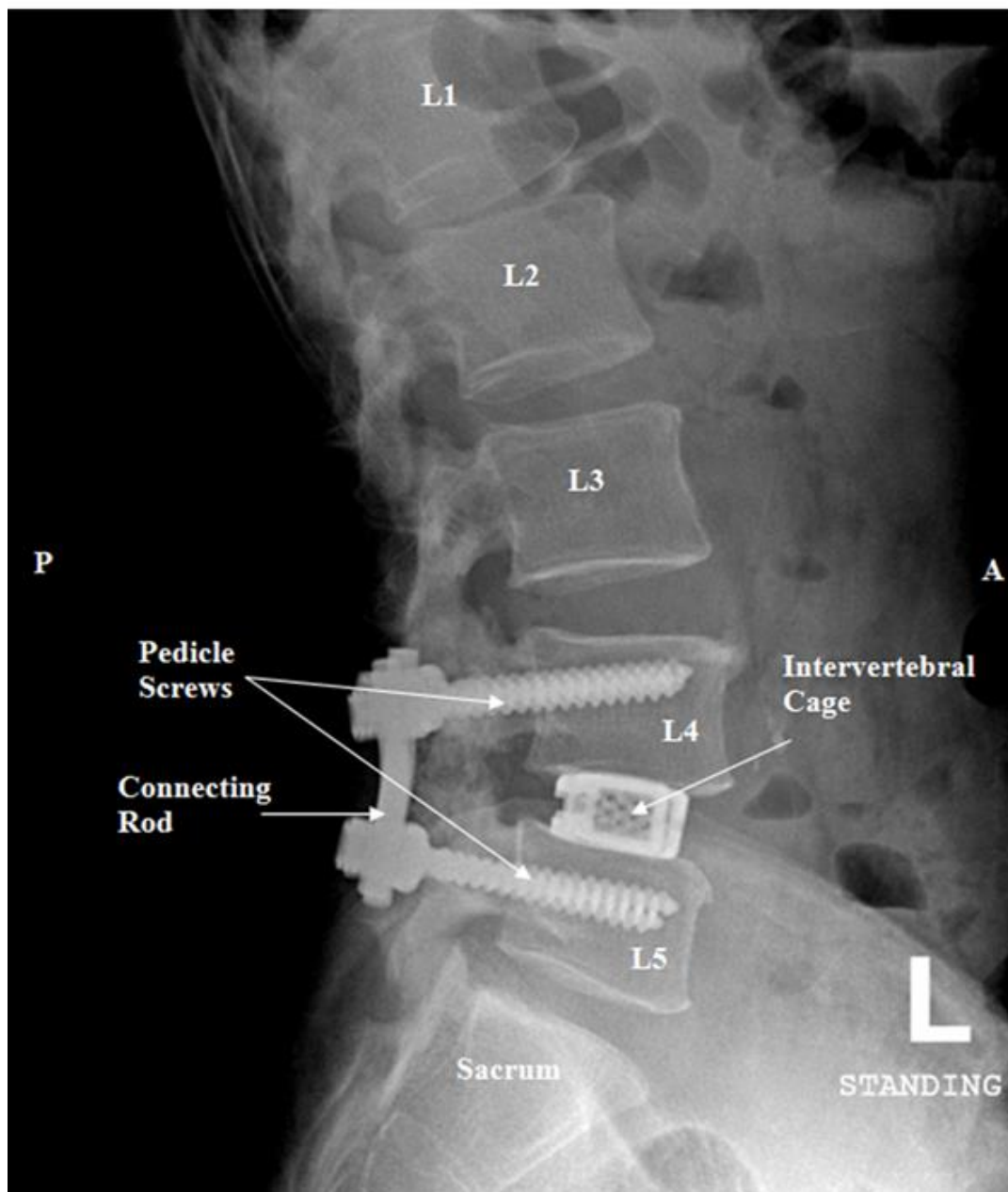

Figure 3: Pedicle Screw Instrumented Fusion

Lumbar spine fusion is used to eliminate motion and provide stability across degenerative or unstable motion segments. This lateral x-ray of the lumbar spine shows pedicle screw instrumentation of the L4 vertebra and L5 vertebra. An intervertebral cage is also used to re-establish lost vertebral disk height and to promote bony fusion.

The pedicle represents the only safe bony channel available to enter the vertebral body from a posterior approach. The pedicle is much like a tunnel with a softer cancellous core and dense cortical shell. As such, the angle of the pedicle to the vertebral body determines the angle at which a screw must be inserted in order to enter the body without breaking through the pedicle walls. Outside of these walls exist important neurological structures, such as nerve roots and spinal cord. Knowledge of the angle that the pedicle joins the body is critical as surgeons usually cannot visualize the pedicle directly. Fortunately, these angles have been well described in morphometric studies [2, 3]. In the transverse plane, the pedicle emerges from the thoracic vertebral body at an angle of approximately 10 degrees of medial angulation (from posterolateral to anteromedial), which then increases progressively in the lumbar spine such that, at L5, the medial angulation of the pedicle measures on average of 30 degrees. In the sagittal plane, the pedicle is angled at 15 degrees cephalad (angled up with the subject standing) in the thoracic spine while remaining neutral in the lumbar spine with the exception of L5 where on average five degrees of caudal angulation exists compared to the vertebral body.

In regards to the possible length of instrumentation used in the pedicle, morphometric studies have demonstrated an average distance of 40mm from the posterior aspect of the pedicle to the anterior aspect of vertebral body in the thoracic spine and on average 50mm in the lumbar spine (as measured from the posterior aspect of the pedicle going through the pedicle along its long axis towards the anterior vertebral body. For the current commercially available pedicle screw systems, the ideal length of screw depth insertion is utilized to allow for maximum strength with minimum complications. Biomechanical studies show that approximately 60% of the screw strength is within the pedicle, while the remaining 40% is divided equally between the cancellous screw purchase in the vertebral body and the anterior vertebral cortex; for a screw which penetrates the anterior wall of the vertebral body [1]. In other words, a screw that penetrates the anterior vertebral body will be 20% stronger than a screw which remains in the body. However, perforation of the anterior vertebral cortex is associated with potential injury to the major anterior vasculature including the aorta. Thus, the risk

associated with breaching the anterior cortex is thought to exceed the benefits gained from additional strength [7, 8]. Although this rule applies to the entire thoracic and lumbar spine, the values are reversed in the sacrum. The sacrum has a strong anterior weight bearing column of bone that contributes to 60% of the screw strength and therefore consideration for anterior wall penetration in this region should be made [7].

As such, a surgeon should insert a pedicle screw such that the screw: 1) is inserted along the long axis of the pedicle, 2) has the largest possible diameter without fracturing the pedicle, and 3) reaches maximum length without perforating the anterior vertebral body wall (with exception of sacrum) [7]. In order to achieve these goals, any instrumentation designed as a pedicle screw device must be engineered to allow for insertion at different angles while allowing for variability in length as well as diameter.

1.3 HISTORY OF THE PEDICLE SCREW

The development of pedicle screws has revolutionized spinal surgery, with widespread use and acceptance by spinal surgeons across the world. The current pedicle screw design is a relatively recent invention, having been developed in 1970. However, the first described treatment of spinal disease with surgical instrumentation was published by Hadra in 1891, during which time, he utilized a wiring technique to stabilize a pathologic cervical spine fracture-dislocation secondary to Pott's disease [9] [10]. The person often credited with developing methods of screw fixation in the spine is King, who introduced facet screws for the fusion of degenerative lumbar disease in 1948 [11]. Later on, Boucher was first to consider pedicle fixation by extending the screw previously described by King to the pedicle, and although this was not truly a pedicle screw in the modern sense, Boucher is credited for having conceptualized pedicle screw fixation in spinal surgery [12]. The current technique of passing a screw through the isthmus of the pedicle in order to gain fixation in the pedicle and vertebral body was first described by Harrington and Tullose in 1969 for use in treatment of spondylolisthesis in children [13]. However, this technique did not become widely accepted in North America for another 10 years. During the 1979 American Academy of Orthopedic Surgeons meeting in San Francisco, Roy-Camille introduced the pedicle screw fixation method to North American surgeons [5]. Shortly after, Steffee helped further develop

pedicle instrumentation and broadened its utility by inventing the variable-screw-placement plate, which allowed for the pedicle screws to be placed according to individual patient anatomy [14]. Nonetheless, at this point in its development, spinal instrumentation lacked the high-quality internal fixation methods that were available for long bones [5]. Significant research and effort was therefore put into place in the development of the modern spinal instrumentation systems, the majority of which utilizes novel materials such as titanium alloys. One significant design change was the addition of “tulips”, allowing for variable angle attachment of each screw to a rod with few limitations for screw placement.

The development of pedicle screws and its use by spinal surgeons has dramatically improved the surgical care of patients with spinal disease. Improved clinical outcomes have been demonstrated in a variety of spinal disorders including: scoliosis, kyphosis, spinal fractures, spondylolisthesis, degenerative lumbar disease, neoplasms, autoimmune disease and more. In the case of scoliosis, the use of pedicle screws has resulted in better achievement and maintenance of alignment correction, along with a reduction in the need for brace utilization [15-17]. In trauma, the pedicle screw construct has allowed surgeons to fuse fewer segments and better correct post-traumatic kyphotic deformities with greater success [18-23]. For the treatment of spondylolisthesis, the fusion rates have increase substantially. The surgeon’s ability to reduce and maintain the deformity has also improved, increasing the overall rate of surgical success and acceptable outcome with a corresponding reduction in overall risk. Furthermore, the use of pedicle screw fixation has allowed for percutaneous and minimally invasive approaches to be developed for the treatment of spondylolisthesis and other spinal deformities [24-29]. In the treatment of cancer, the use of short constructs with only a few levels instrumented has allowed for safe radical resection of primary spinal tumors to be performed with improved outcomes [30, 31].

Although the pedicle screw represents state of the art treatment in spinal disease, it has major limitations. One of these is the inability of the current screw designs to provide sufficient fixation in osteoporotic bone, or with revision surgery, as well as insufficient stability in badly traumatized patients.

In the case of spinal instrumentation, the screw-bone interface is the critical element that determines the strength of the surgical construct and, therefore, failure or success of the surgery. This screw-bone interface is compromised substantially in osteoporosis [32-45]. Beyond bone quality, other factors have been shown to effect screw bone fixation including: screw diameter pedicle match (*i.e.*, ability of screw to fill the pedicle), screw length, thread pitch, thread type, shape of the minor diameter, shape of major diameter, angle of screw insertion, use of cross-linking, insertion torque, pre-tapping the pedicle, bilateralism of fixation, augmentation with bone cement, use of hollow screws and more [46-72]. Although this knowledge has been incorporated in today's spinal instrumentation and surgical techniques, the issue of bone fixation remains a concern in osteoporotic patients. Investigators have demonstrated that elderly patients with multiple spontaneous compression fractures, secondary to osteoporosis, are very poor candidates for pedicle screw fixation such that the advantages gained by modern forms of instrumentation are neutralized in osteoporotic patients [44]. Soshi *et al.* have described the JIKEI Index, which relates bone-mineral density and pedicle screw pullout strength using an x-ray based scheme. The patient is graded on a scale ranging from 0 to 3. A grading of 0 represents normal trabecular pattern and density while grade 3 demonstrates very poor bone quality with disappearance of transverse trabeculae and ground-glass appearance of bone on x-ray imaging. Spontaneous compression fractures, which are commonly seen in elderly, generally occur in stages 2 and 3 of this grading system, in which bone quality is so poor that the authors concluded pedicle fixation to be contraindicated [44]. However, since pedicle screw fixation represents the best mode of fixation available in spine surgery, only inferior options for the treatment of these patients remain. Some authors have recommend a hook based construct in osteoporotic patients, but, this does not lead to an improved outcome [34].

In order to address the issue of poor screw purchase in osteoporotic bone, researchers have proposed methods to further supplement the pedicle screw fixation. One such technique is the addition of bone cement such as methyl methacrylate, calcium triglyceride, or polypropylene glycol fumarate [35, 48, 57, 59, 65, 73]. Although this technique demonstrates significant improvement in pullout strength and construct

rigidity, it carries the risk of cement extrusion into the spinal canal which can lead to considerable complications, the worst being paralysis.

1.4 IMPLANT MATERIALS

Metallurgy (the study of metals and their properties) is of importance when designing and using metallic implants for surgical purposes. Without this knowledge, inappropriate material selection can lead to failure of an implant despite appropriate geometric design. Most spinal implants are made of an alloy, which is a mixture of metallic elements. These elements commonly include: aluminum, titanium, vanadium, chromium, manganese, iron, cobalt, nickel, zirconium, niobium and molybdenum [1]. Out of these, only titanium is used in its pure form to make spinal implants, with four different commercially available grades; grade 1 is the most pure, containing no contaminants, while grade 4 is the least pure. The higher grades have higher moduli of elasticity and increased tensile strength, making them a better option for use in production of spinal instrumentation. Currently, the alloys used in the manufacturing of spinal implants and, in particular, pedicle screw systems are: 316L stainless steel, 22-13-5 stainless steel, Co-Cr-Mo and Ti-6Al-4V (a mixture of titanium, aluminum and vanadium). Although many different materials have been investigated for manufacturing of pedicle screws, the most widely used material for pedicles screw production is the alloy form of titanium. This alloy is ideal for spinal instrumentation due to: 1) excellent magnetic resonance imaging (MRI) compatibility with minimal “noise” production compared to other metals, 2) relatively low modulus of elasticity when compared to the other commonly used surgical metals listed above, and 3) decreased allergic reactions compared to metals containing nickel or chromium. The lower modulus of elasticity allows for a less stiff construct that reduces the phenomenon of stress shielding (*i.e.*, bone resorption), which leads to osteoporosis around implants [74]. However, stainless steel and cobalt chrome continue to be valid options as implant materials for spinal surgery. Some systems utilize a variety of materials for different parts of the system to create a hybrid construct (for example, titanium alloy for the screw and cobalt chromium for the connecting rods) [4, 75].

1.5 SCREW DESIGN

As previously mentioned, pedicle screws are commonly utilized in surgical stabilization of the spine (*i.e.*, spinal fusion surgery). The indications for their use extend from pediatric to adult patients. As the primary mode of fixation in deformity, trauma, as well as the management of chronic or degenerative conditions of the spine, their ability to retain bony purchase is paramount to procedural success. Even though current pedicle screws offer the strongest surgical construct available; in cases of osteoporosis, revision surgery or severe trauma, conventional pedicle screws can be inadequate, leading to early failure through loss of fixation (*i.e.*, screw loosening).

Figure 4 illustrates the key screw features that must be considered in screw design. The screw can be divided into 4 basic components: head, core, thread and tip. Alterations to any of these components will change the mechanical properties of the screw, as well as its interface with bone. Screws are commonly utilized in surgical procedures involving bone, and different screw attributes and designs have been well studied and optimized to allow for the best possible fixation strength to be achieved.

The head of spinal pedicle screws is often referred to as a ‘tulip’. Generally a screw head functions to resist the translational force created by the rotation of the screw once the screw is fully tightened with its head abutting against the surface into which the screw is placed. However, for modern pedicle screws, the head must play two roles: resist the translation force and act as the anchor point for fixation to a rod which connects the other screws along the screw-rod construct. This mechanism has been well studied and well designed and is very rarely the point of failure. As such the screw design modifications suggested in this thesis do not attempt to alter the tulip designs.

The core of the screw (*i.e.*, minor diameter) is the primary determinant of the screw’s fracture resistance to both bending and torsional forces. The screw’s strength is proportional to the cube of the minor diameter. As such, the fracture strength of the

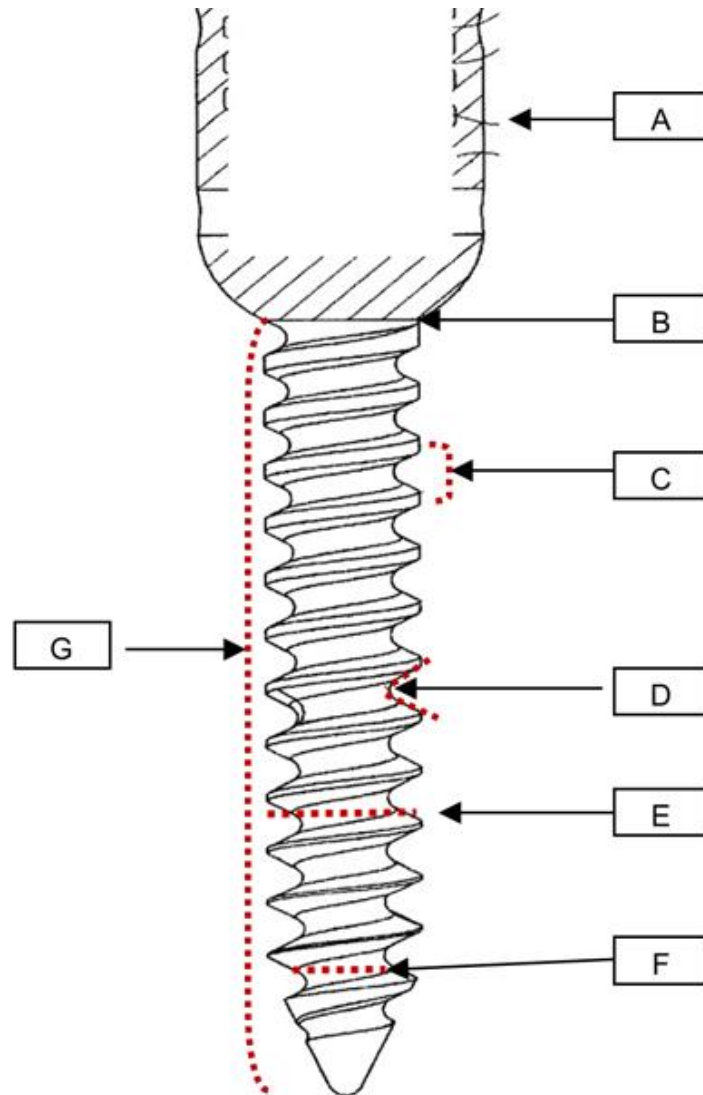

Figure 4: Basic Screw and Thread Terminology

Key feature of the screw design are labeled: A = screw head or tulip, B = head body junction, C = pitch, D = thread angle, E = major diameter, F = minor diameter and G = screw length.

screw increases exponentially as the minor diameter is increased [76]. It would then seem intuitive that the screw with the largest minor diameter that is anatomically possible would be the best treatment option; however, this is not the case. One issue with a large core diameter is sacrifice of the thread depth, a factor discussed in detail below. Furthermore, increased minor diameter results in a stiffer screw and subsequently a stiffer surgical construct, which has been associated with stress shielding of the bone [74]. This must be weighed against the fact that if the construct is not rigid enough, excessive movement may result in non-union [77]. The other factor to consider regarding minor diameter is its shape. Investigators have studied the effect of changing the shape of the core from cylindrical to conical with the end closer to the head of the screw having a larger diameter. This produces compression forces at the bone screw interface and, despite sacrificing thread depth near the screw head, has been shown to result in increased pull-out strength [55]. One example of such a screw is the Xia® instrumentation system (Stryker®, Spine Michigan, Kalamazoo).

The screw thread is of critical importance to pull-out strength and multiple aspects of the thread can be modified. The 3 most critical design elements are thread depth, pitch, and type. Thread depth is defined as the difference between the minor and major diameters, where the latter is the largest diameter of screw measured to the tips of the threads. Generally speaking, larger thread depth results in better bone purchase and stronger screw pull-out in soft cancellous bone such as the bone in the vertebral body. However, increasing thread depth results in sacrifice of minor diameter, and thus fracture strength. Thread pitch, when considered in metric measurement, is defined as the distance between two adjacent threads. Alternatively, the pitch is defined as the number of threads per inch or TPI in the standard measurement system. For simplicity, the metric system will be used to define screw pitch in this thesis. Finally, thread type refers to the shape of the thread, of which there are nearly infinite options. The designs utilized most often in surgical implants include: “V” shaped threads (which are in most cases a 60 degree “V”), buttress shaped threads and square shaped threads.

In surgery, two types of screws are generally utilized depending on the type of bone that is being instrumented (cortical bone vs. cancellous bone). Cortical screws are

more like machine screws, meaning that they have a low thread depth and low thread pitch, an ideal combination for gaining screw purchase in a hard material. On the other hand, cancellous screws are more like wood screws in that they have a high thread pitch and large thread depth. This combination allows for screw purchase in relatively weak material such as cancellous bone because it allows for a larger amount of bone to be present between each thread thus increasing its strength. Since pedicle screw fixation (even within the pedicle) is mostly within cancellous bone [78], most pedicle screws are designed like wood screws.

For pedicle screws, the ideal thread type, shape, pitch, core shape, and size, have been determined [1, 4, 5, 55, 69]. Ultimately, for the purposes of increasing pull out strength, V shaped threads should be utilized with a pitch of approximately 2.8mm and thread depth of approximately 1mm with a core that has a conical shape. Some manufacturers (such as the Xia® screw from Stryker®) have capitalized on these parameters, by producing screws with these specifications that have proven to be very successful in clinical use. Therefore, any new screw design must consider incorporation of these previously established design features.

Several types of bone-implant interfaces are employed to achieve bony fixation. These include: penetrating, gripping, conforming, osteointegration, and abutting interfaces. Current pedicle screw designs primarily take advantage of the penetrating interface to gain fixation into bone. However, in weaker or compromised bone, this single mode may be insufficient to achieve the necessary required fixation. It may be possible to provide additional abutting fixation at the anterior aspect of the pedicle or the junction at which the pedicle connects to the body by changing the shape of the screw at this site (*i.e.*, penetrating and abutting). Other spinal instrumentations work by utilizing other methods of fixation. For example, hooks used in surgery work by gripping the bone, and when cement is used, it functions by conforming to the bone. Another method of fixation depends on bone in or on growth on to the device called osteointegration, which can be expected if the implant is coated with substances such hydroxyl apatite [79, 80].

In an attempt to address the deficiency of a pedicle screw for use in osteoporotic bone investigators have attempted to design and produce expandable pedicle screws with some success. These screws have been reported to increase mean pullout strength by approximately 30% while also demonstrating safe in-vivo use [35, 81-85]. However, little clinical data exist today to support the efficacy or safety of these devices. An example of such a device available for use in North America is the OsseoScrew-Zodiac® (Alphatec Spine Inc, Carlsbad, CA). This screw is an expandable titanium screw marketed for use in osteoporosis. Short term clinical data and *in-vitro* biomechanical studies have been performed on this device. The biomechanical studies do demonstrate a 30% increase in ultimate failure load as compared to standard screw and it is debatable if a modest increase outweighs the added cost and complexity.

1.6 THESIS RATIONALE

The pedicle screw has revolutionized spinal surgery. However, the lack of sufficiently strong instrumentation for the treatment of patient with compromised bone justifies the need for development of a novel fixation device. By designing a screw that combines penetrating and abutting fixation, this may be realized. By drawing an analogy to expanding drywall screws, which have a successful track record for achieving a strong grip into an otherwise weak and fragile drywall surface, the concept of developing a pedicle screw with an expansion-type mechanism for gaining fixation in a compromised vertebra was developed. This lead to the overall thesis objective of: designing, building and testing a pedicle screw, capable of expanding within the vertebral body post insertion.

1.7 OBJECTIVE AND HYPOTHESIS

The specific objectives of this study were:

1. to design multiple versions of novel pedicle screws capable of expanding after insertion through the pedicle;

2. to build working prototypes of these designs using recently available rapid-prototyping technology at our institution (*i.e.*, selective laser melting machine (SLM));
3. to test and compare these designs against each other and the current 'gold standard' pedicle screws in pullout testing using Sawbones; and
4. to develop a final working prototype and compare it to a 'gold standard' pedicle screw in osteoporotic cadaveric models.

The hypotheses of this investigation were:

1. a novel expanding screw design could be built using SLM technology, and
2. this novel expanding screw design would improve bony fixation in the osteoporotic spine as demonstrated through improved pullout strength compared to the current 'gold standard' traditional pedicle screw.

CHAPTER 2: MATERIALS AND METHODS

2.1 IMPLANT DESIGN

To develop an effective and user friendly expanding pedicle screw system, a design team was assembled consisting of fellowship trained spinal surgeons and biomechanical engineers. This expert team determined several critical design parameters for the novel pedicle screw design. The team determined that: 1) the screws should be usable with standard surgical techniques for pedicle screws, 2) the amount of expansion should be adjustable intraoperative, 3) the expansion should occur in the same location, specifically the vertebral-body pedicle junction, despite anatomic variations amongst patients, 4) the expansion should be reversible so that the screw can be extracted if required, and 5) the pullout strength of the new design should be at least 50% greater than the pull-out strength of the 'gold standard' screw in osteoporotic bone.

To achieve these goals, four different screws were initially taken through the conceptualization stage to prototype development. Three of these designs utilized the approach of an expanding helical shell over top of a central threaded core (Figures 5–7). Expansion of the helix is achieved post insertion by turning the central core which contracts the helix while increasing its diameter (see Appendix B). The expansion is dictated by the leading and lag angles of the helix, and the number of turns given to the central core. Through the building of multiple prototypes and subsequent pilot testing, it was established that an angle differential of 40 degrees was necessary to optimize device expansion, meaning that the helix groove is cut in such a manner that the top wall is angled at 80 degrees and the bottom wall at 40 degrees (Figure 7). This is critical as it allows for a gradient inclination from one wall to the next, reducing resistance during expansion. The difference between the three designs is the length of the helical screw shell. In Design #1, the helix runs nearly the entire length of the screw (referred to as the complete helix). In Design #2, the helix is only the end of the screw (referred to the distal helix). Design #3 has the helix in the central region of the screw (referred to as the central helix). The 4th design, utilizes a simpler expansion mechanism. It has two open slits on each side that hinge on a single pivot point near the head of the screw and open

due to the presence of an internal ramp (Figure 9). These two slits open similar to a window, thereby naming this design as a 'window' screw.

2.1.1 COMPLETE HELIX

The complete helix screw is designed specifically for pedicle fixation in the lumbar spine (Figure 5). The dimensions of the screw are based on the most commonly utilized pedicle screw in the lumbar spine (Figure 6). The length of the screw is 45mm from screw tip to the shaft-head junction. The minor diameter measures 4.5mm while the major diameter is 6.5mm. The threads are V shaped with a 60 degree angle and the thread pitch is set at 2.8mm with a resulting thread depth of 1mm. The screw body is hollow with a cylindrical bore diameter of 3.0mm. The distal 4.0 mm (at the tip) is cut to 2.5mm and has an inner thread based on a metric M3 thread (pitch = 0.5mm). The main novelty of the expanding shell is the grooved, left-handed helix. The direction of the helix is reversed from that of the screw thread to prevent the helix from unwinding during screw insertion. The pitch of the helix is 5mm. Of notable importance is the angle of the walls of the helix (Figure 7). For the helical screw to expand post-insertion, an inner screw is required (Figure 5). The inner screw is designed as a standard shaft screw with slight modifications. It has an overall length of 45mm and is threaded at the tip for a total of 25mm with standard M3 threading to match the inner threading of the previously described helical screw tip. The head of this inner screw is designed to accept a 2.5mm Hex driver. The head-body junction is contoured to fit flush against the top of the helical screw upon complete insertion, providing the buttressing force that in turn expands the outer screw shell.

The helical screw shell works simply by shortening in length during insertion of the inner screw. Once the helix has closed, the walls of the helix come into contact with one another and overlap, causing expansion of the outer screw shell in a circumferential fashion. Furthermore, since the expansion is allowed to occur along the entire length of the helix, the expansion will follow the path of least resistance, preferentially expanding inside of the vertebral body, abutting against the inner wall of the pedicle for support. The preferential expansion is an ideal characteristic for an expandable device because it

protects against fracture of the pedicle or body if the screw is not placed perfectly in the center of the pedicle or vertebral body.

This device uses a helical design to allow for reduced resistance during expansion of the screw post insertion into the pedicle. The helix is unique in that it allows for the amount of expansion to be known (*i.e.*, directly related to the number of turns applied to the inner screw), and the surgeon will be able to dial in the amount based on anatomic limitations or patient specific parameters.

2.1.2 DISTAL AND CENTRAL HELIX

To control the exact location of expansion, placement of the helix on the screw can be altered (*i.e.*, distal and central helix). The distal and central helix were identical in every aspect to the complete helix with the exception of location (Figure 8). In the distal helix design, the helix starts 5mm from the tip and extends towards the head of the screw for a total of 25mm (*i.e.*, leaving the top 15mm of the screw without helix). The central helix has the helix designed into its central aspect with the top and bottom 10mm of the screw not having a helix. These are only a few of the many modifications that could also be viable variations of the proposed helical screw shell. However, ultimately the goal is to have a device that expands at the pedicle body junction and abuts against the back of the body preventing screw pullout, which is accomplished with the current designs.

2.1.3 WINDOW SCREW

The window screw differs from the others mainly by the method that it achieves expansion and abutment at the pedicle body interface. The overall length of this screw is also 45mm with a minor diameter of 4.5mm and major diameter of 6.5mm. The threads are V shaped with a pitch of 2.5mm and thread depth of 1mm. The head is an 8mm hex nut. The expansion mechanism of this screw occurs through the opening of 2 slits on opposite sides of the screw designed to open in the cranial and caudal ends of the pedicle via insertion of a 3mm inner set screw. This screw is designed such that it is hollow for a total length of 30mm from head down. The top part of the screw is threaded on the inside



Figure 5: Design of complete helix expandable pedicle screw and the central threaded core

These images demonstrated the Outer Shell or the expandable portion of the design as well as the Inner Screw which drives the expansion after insertion into the Outer Shell.

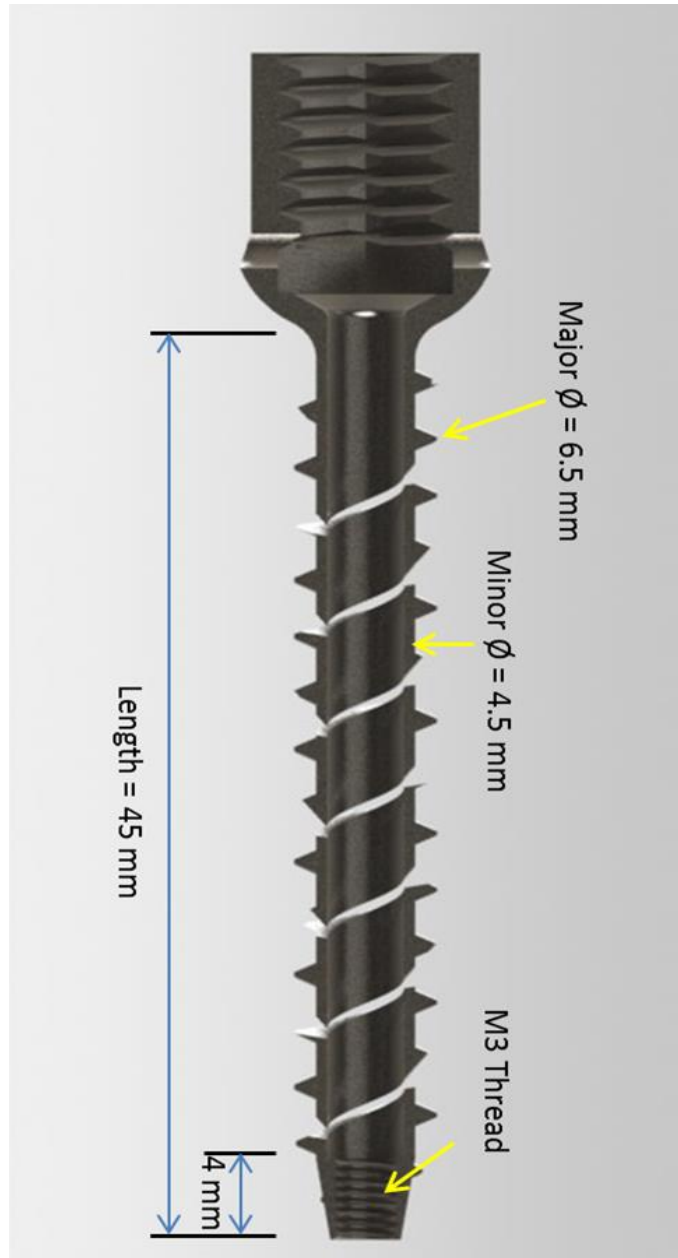

Figure 6: Fully Helical Expandable Screw Cross section

Cross sectional rendering of the Outer shell demonstrated the threaded distal segment into which the Inner screw is engaged as well as screw dimensions.

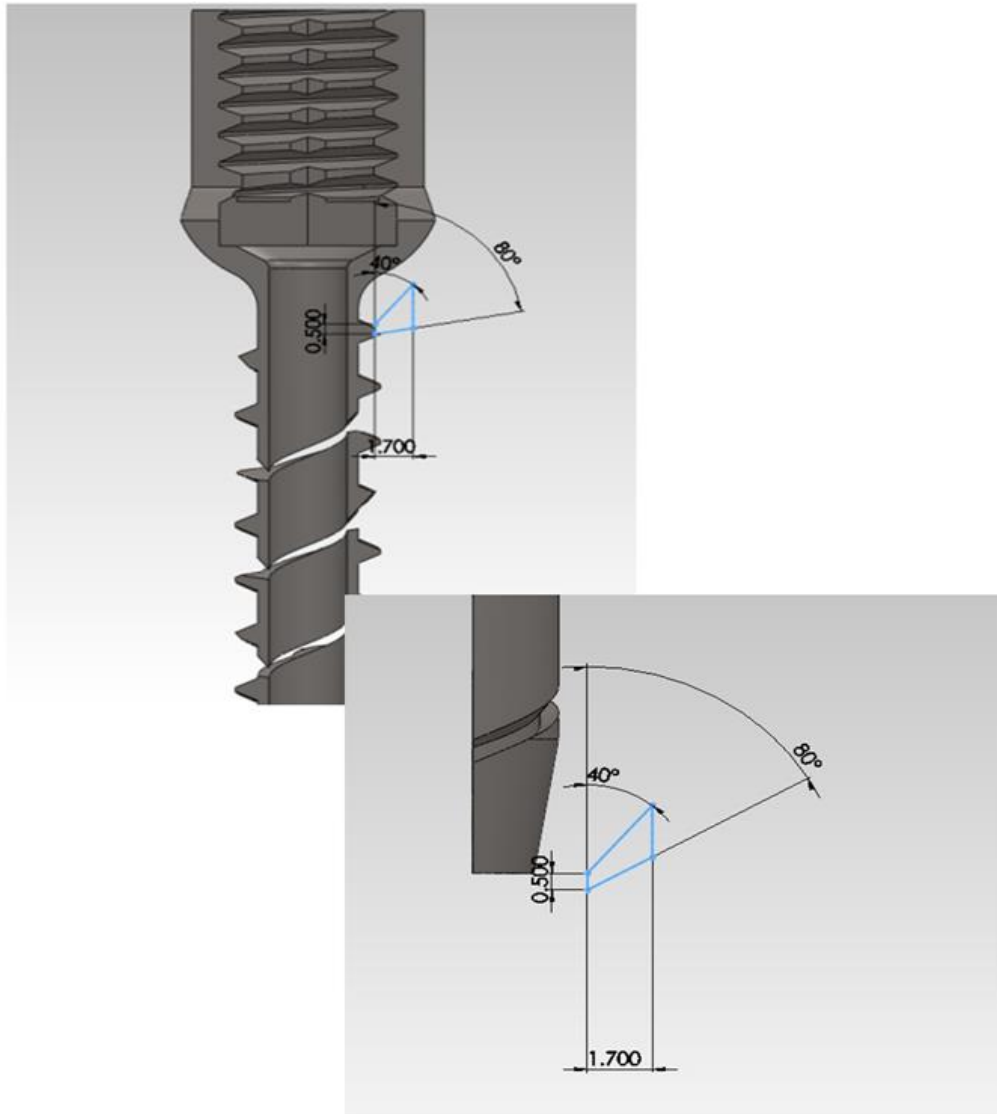

Figure 7: Side wall angle and dimensions for helical screw

Dashed box in top image is shown in lower inset image up close. The wall of the helix is designed with a 40 degree differential in angle and total wall thickness of 0.5mm.



Figure 8: Modification of the complete helical screw

By changing the location of the helix, two modifications to the complete helix screw were created: (A) central helix screw, and (B) distal helix screw.

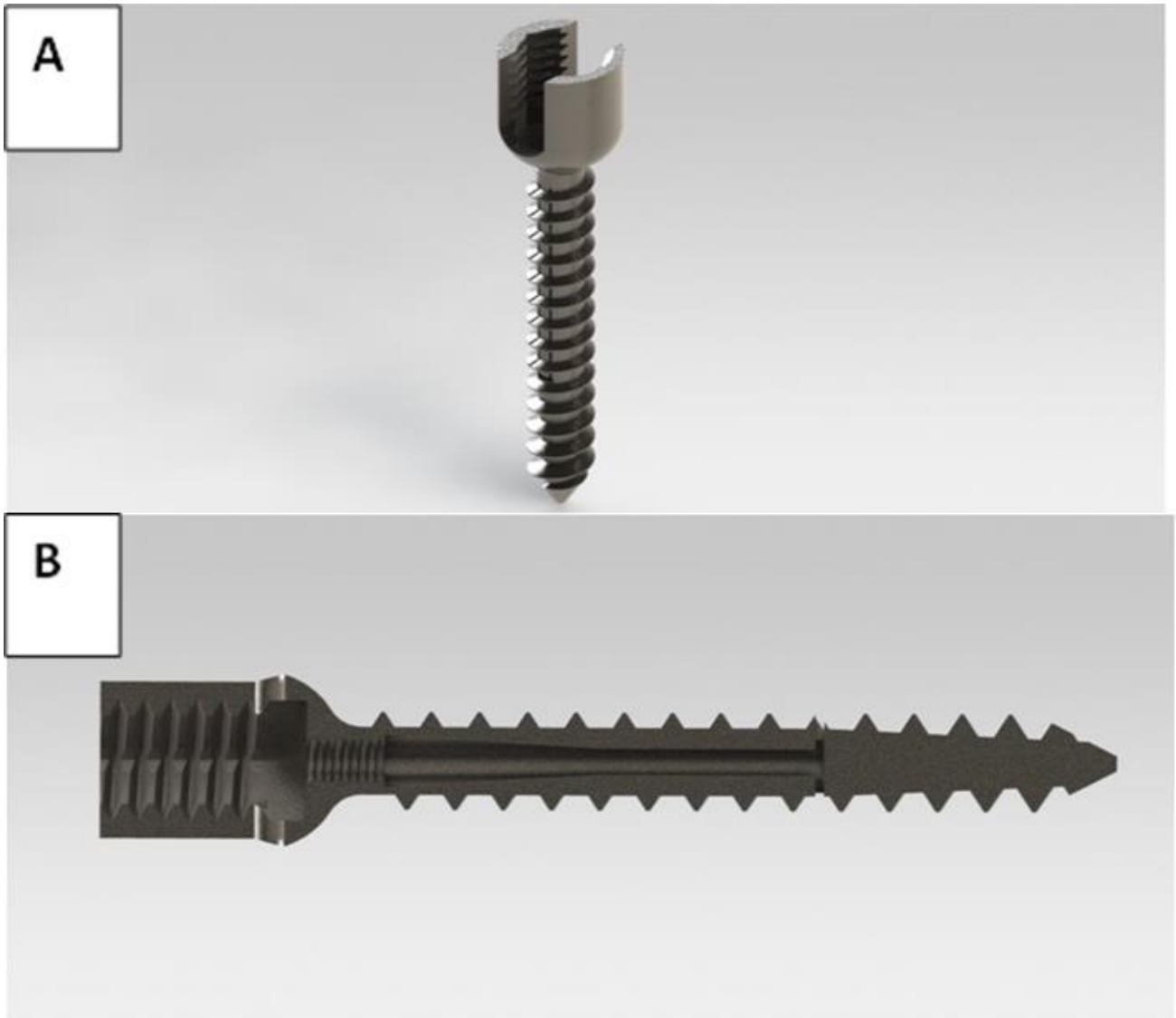

Figure 9: “Window” Srew design

(A) Rendition of the window screw. (B) Cross section of the window screw. 30mm of the screw is bored out and the top is threaded with M3 threading allowing for insertion of inner screw which will expand the screw due to a sloped inner wall.

for a total length of 5mm with standard M3 thread, to allow for the inner screw to be threaded into place. The inner screw is a 3.0mm metric M3 set screw with thread pitch of 0.5mm. It is threaded for its total length and is driven by a 1mm hex driver. Upon full insertion it sits flush with the top of the expandable screw. The two “windows” have a length of 25mm and width of 2mm, on the inside, they are designed with a 12.5 degree ramp which starts at the tip of the “window” and goes towards the tip of the screw for a total distance of 1cm. Overall, the insertion of a 3mm inner screw, results in a maximum diameter of 12mm at the tip of the windows.

2.2 TESTING PROTOCOL

Five copies of the four screw prototypes described in Sections 2.1.1 through 2.1.3 were produced and prepared for testing. These screws were manufactured from grade 316L stainless steel on a SLM machine (DM 125, 3D Systems, South Carolina, USA) housed in the Robarts Research Institute of Western University. After extraction from the SLM, all screws were further polished and tapped by hand to remove any residue or burrs remaining from the manufacturing process. All screws were carefully examined under 2.5 times magnification for defects. Size accuracy (*i.e.*, length = 45mm and major diameter = 6.5mm) was confirmed utilizing an electronic caliper with accuracy of $\pm 0.02\text{mm}$ (Mitutoyo®, Tokyo, Japan).

2.2.1 SAWBONES TESTING

Thirteen L5 Sawbones® (Pacific Research Laboratories, USA), specifically designed to be radio-opaque under fluoroscopy, were prepared for screw insertion. Each vertebra was placed in a small clamp and oriented such that the posterior vertebral body was horizontal. This was accomplished by using a laser level to ensure that the posterior vertebral body remained horizontal throughout the screw hole preparation. A 45mm deep pilot hole was drilled using a 2.5mm “twist” metric drill bit attached to a Dremel® 4000 Rotary Tool mounted on a Dremel® Works Station™ Model 220-01. The rotary tool was set at 5000 RPM, while the work station was tilted to 30 degrees. Additionally, a 5 degree wedge was placed under the clamp. Combined, this allowed for the consistent drilling of every pedicle with 30 degrees of medial angulation and 5

degrees of caudal angulation. This trajectory was selected based on previously reported morphometric characteristics data [2]. The pilot track was followed with a standard straight pedicle probe to a depth of 45mm; it was then rotated 180 degrees in each direction once, prior to removal as per standard surgical technique. The pedicle probe was used to allow the surgeon proprioceptive feedback while creating a passage for the pedicle screw thus minimizing the chance of breakout of the pedicle (Figure 10). These preparations were performed in both pedicles of each Sawbone®, creating a total of 26 testing sites. Five screws of each type (5 Distal Helix, 5 Central Helix, 5 Complete Helix, 5 Window Screws) were selected and randomized to one of the testing locations. For ‘gold standard’ control, 5 size-matched (*i.e.*, 6.5mm by 45mm) screws from the Xia Titanium pedicle screws system were utilized (Stryker, Xia spine system, Kalamazoo, Michigan, USA) and placed in randomized testing sites. The screws were inserted by hand, maintaining a constant angle and speed by a trained spine surgeon until the entire length of the screw had entered the vertebra. The screws were stopped 3mm prior to reaching the end of the screw, which was not dependent on insertional torque. For the helical screws, the central core was inserted to stabilize the screw during implantation; however, the screws were not expanded until after they were fully inserted. To produce expansion, all of the helical screws required 20 revolutions on the inner core, except for the Complete Helix screws that required 25 revolutions. The inner core of the Window screw was inserted to its full length. The specimens were all subsequently imaged using fluoroscopy (C-arm model 850, General Electric Mississauga, ON,) to confirm appropriate screw trajectory and expansion (Figure 11). Orthogonal views were used to confirm central placement of all screws within the pedicle. The vertebrae were also examined thoroughly to rule out any fractures or defects caused by screw insertion and expansion.

Each of the 13 vertebrae were then potted in metal boxes using Denstone™ cement (Heraeus Kulzer Inc., South Bend, IN). To increase fixation, several drywall screws were placed in the vertebra prior to potting, and buried within the Denstone. Judicious potting was performed to ensure that the cement did not come

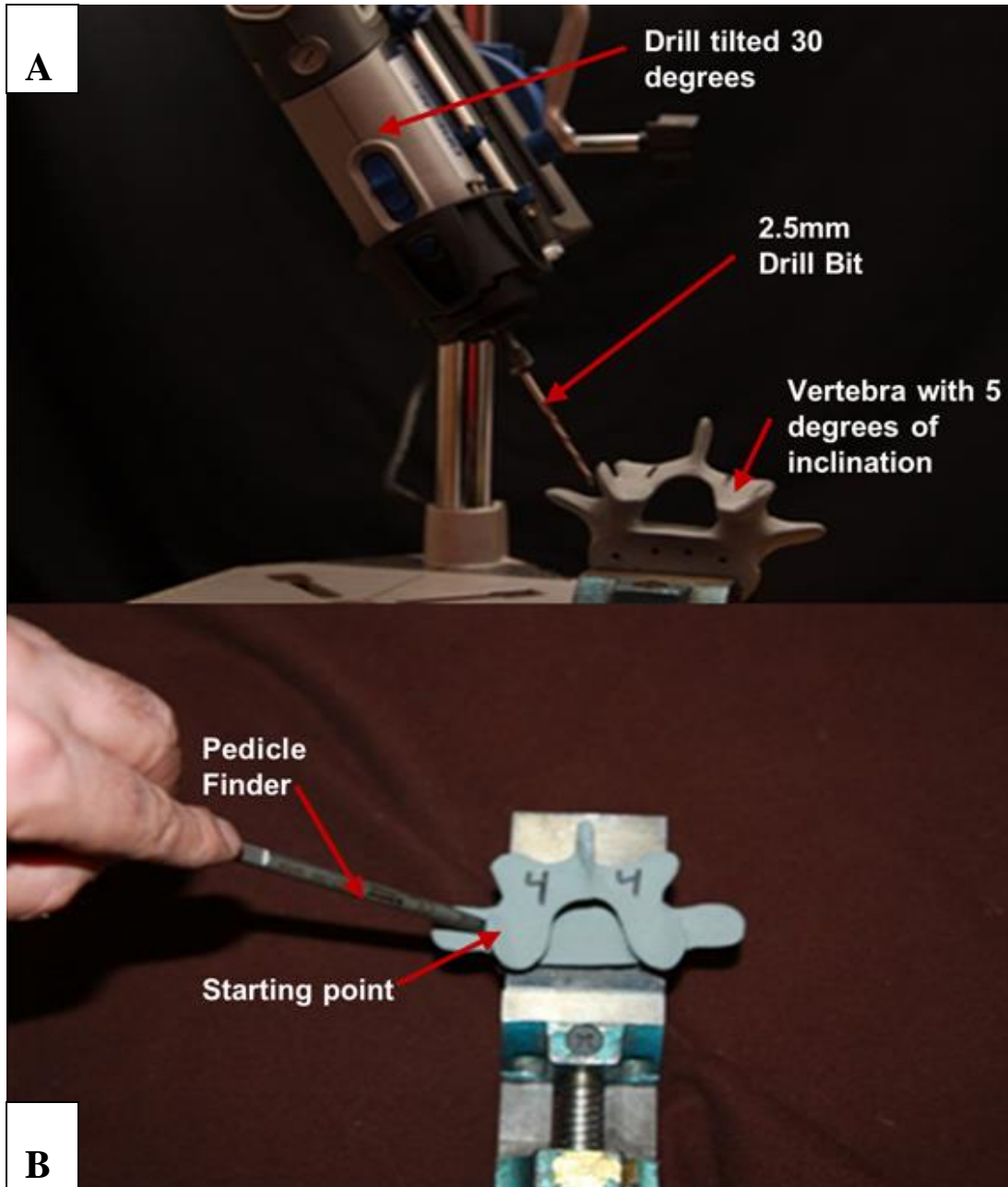

Figure 10: Pedicle Preparations for Screw Insertion

(A) Pilot hole was drilled into the vertebral body with 30 degrees of medialization and 5 degrees of caudal angulation. (B) A standard surgical pedicle probe or “bonker” was inserted as part of the final preparation of the pedicle for screw insertion.

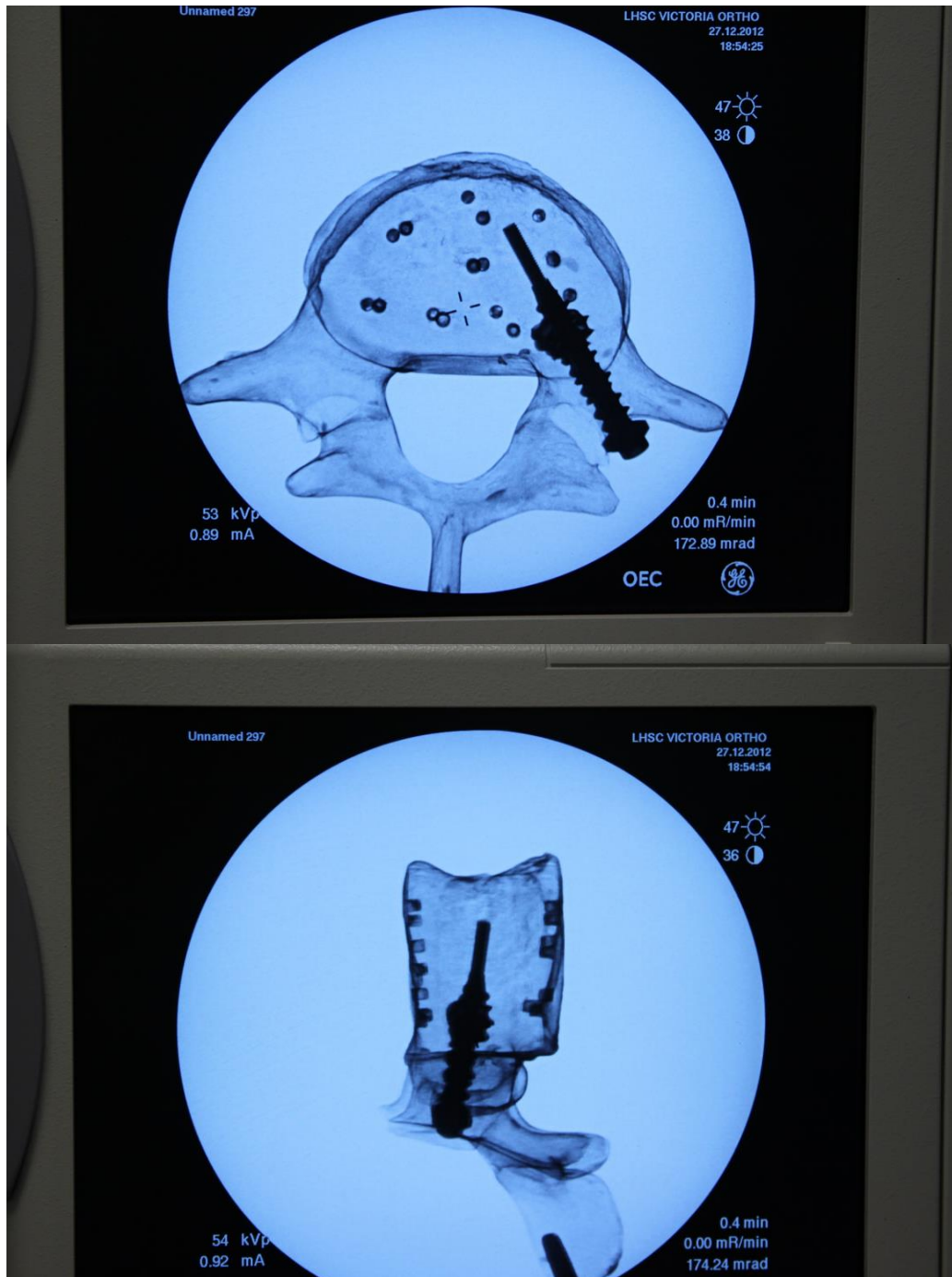

Figure 11: X-Ray Post Screw Insertion

Fluoroscopic image of L5 Vertebra post insertion and expansion of a Fully Helical Expandable screw. (Note: “Dots” observed within the vertebral body are part of the Sawbone® design)

into contact with any portion of the pedicle screw. Post testing, examination of the screws and screw hole was performed to confirm that the Denston had not penetrated the specimen, a concern previously stated by other authors [86]. The potting boxes were mounted on to a materials testing machine (Instron® 8874; Instron, Massachusetts, USA) to allow for axial pullout testing of the screws (Figure 12). The pedicle screws were connected to the Instron's load cell by a custom-made apparatus capable of grabbing a screw head with a low profile. The potted fixture was then attached to a universal joint clamp fixed to the Instron's base table via a bearing platform designed to allow complete freedom in the x - y planes of motion. Because the fixture was free to move in the x and y directions and the angle of pull was adjustable through the universal joint, the line of pull of each screw was standardized. In order to ensure that all screws were positioned vertically prior to pull-out, a 'bulls eye' level was attached to the top of each screw and the universal joint adjusted until the screw was vertically positioned. The screws were then loaded in displacement control at a constant rate of 10mm/minute for a total displacement of 2 cm in accordance with published literature on axial pull out testing and standards set by the American Society for Testing and Materials (ASTM) [35, 81, 82]. Load and displacement data were collected at 100Hz, resulting in approximately 1000 data points per screw tested. Failure was defined as the maximum load or the load peak prior to decrease in load associated with increasing displacement [35, 82, 85]. In addition to randomized placement of the screws, right and left sides of each vertebra were tested in random order to lower potential confounding effects of surgical technique. After the pull-out was completed, the specimen and the screws were closely examined for signs of fracture and damage, and these findings carefully recorded.

From the data points collected, ultimate load was calculated as the largest load experienced during the test. Statistical comparisons were performed using a one-way analysis of variance (ANOVA) test on SPSS v. 17 (IBM, Chicago, IL). Using this data along with feedback from clinicians, the full helical screw design was considered to have the most desirable properties. As such this design was selected for further testing in human osteoporotic cadaveric bone.

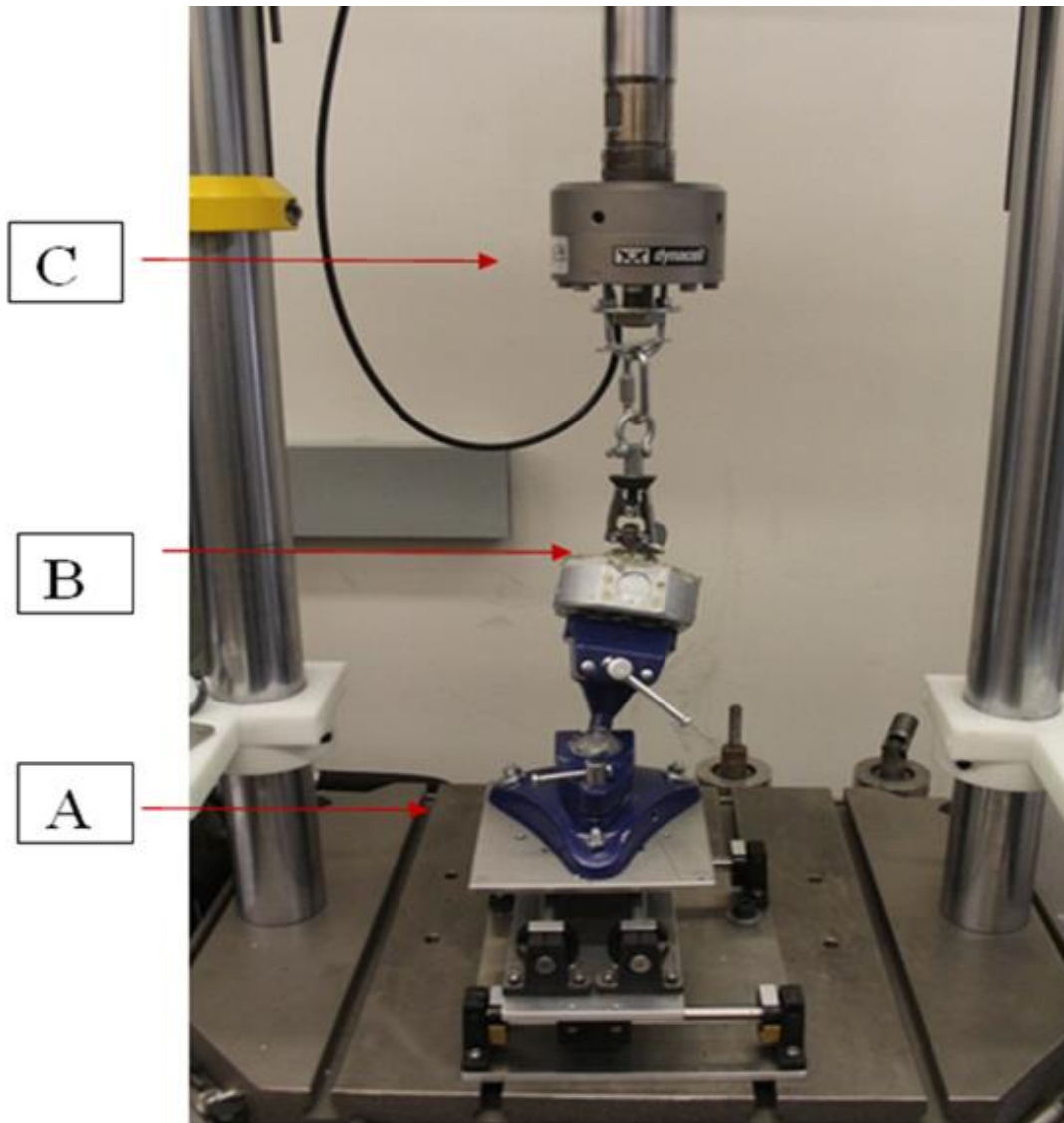

Figure 12: Setup for screw pullout protocol

(A) Specimens were positioned on a universal joint and bearing plate allowing for accurate centering and vertical positioning of all screws. (B) Custom made clamp held the screw with low profile (C) Materials testing machine (Instron 8874; Instron, Massachusetts, USA) allowed for axial pullout testing of the screws.

2.2.2 CADAVERIC TESTING

Additional testing of the complete helix screw was performed using three fresh frozen lumbar cadaveric spines (T12-L5). A total of 16 vertebra or 32 test sites were estimated to be required following a power analysis based on pilot data utilizing a standard deviation of 250, a beta of 0.8 and an alpha of 0.05 to detect a difference equal to or greater than 50% in ultimate failure load. Therefore, six vertebral bodies (T12 to L5) per spine were dissected free of all soft tissues while maintaining the bony elements. All 3 specimens belong to female donors aged 75, 95 and 72 years old, selected due to low bone density. They were examined visually to rule out any bone based defects and scanned using Computed Tomography (GE Discovery 750 HD) to identify any internal bony abnormalities. Helical CT scans were performed with full rotations at 0.6 sec per rotation under high resolution, with scan thickness and interval set at 0.625 mm by 0.625mm. Furthermore, the bone density of each specimen was calculated based on comparison to a known standard phantom bone density placed in the CT scan simultaneously with each specimen. Density is related to Hounsfield units (HU), which were determined for each vertebra using multiple samples from each vertebra. Bone density was subsequently calculated for each specimen. The demographics and bone density of each specimen is listed in Table 1.

For a ‘gold standard’ comparison, replicas of the matching Xia screws were built on the SLM, ensuring standardized screw build quality, materials and finish. Eighteen expandable screws and eighteen standard 45mm X 6.5mm pedicle screws were inserted in the prepared cadaveric specimens using the protocol described in Section 2.1.1. Each vertebra had one standard screw and one expandable screw inserted, with randomization to the left or right pedicle. This allowed for a repeated-measures design, since each screw design was compared within the same vertebra (one screw inserted into each pedicle), therefore improving the study power, such that a limited number of test cadavers were needed to achieve the desired statistical significance. Fluoroscopy was utilized to: 1) confirm screw placement, 2) identify

Specimen	Age (years)	Sex	Reason for Death	Bone Density (mg/cm³)
1	75	Female	Pulmonary Disease	100.6
2	95	Female	Congestive Heart Failure	94.2
3	72	Female	Mitral Valve Disease	96.4

Table 1: Cadaveric specimen demographics and bone density

Age, sex, and reason for death, and bone density of each specimen.

fractures, and 3) confirm screw expansion. The remainder of the testing protocol and potting procedures were identical to those described earlier in Section 2.1.1.

Using load displacement curves, yield load, ultimate load, energy to peak, energy to end of test, and stiffness were calculated. Yield was define as the load under which the load displacement slope changed (*i.e.*, plastic deformity was noted). Energy was calculated as the area under the load displacement curve to peak load as well as to end of protocol. Stiffness was defined as the slope of the load displacement curve before reaching the yield point. The mean values of each of these outcome measures were calculated and statistically compared using independent t-test ($\alpha = 0.05$) for the expandable screw and standard screw.

CHAPTER 3: RESULTS

3.1 SAWBONES TESTING

In all cases, the standard screws and expandable screws were inserted successfully without fractures or break-out of the pedicle. X-ray images of the specimens confirmed central placement of all screws within the pedicle with appropriate angulation following the anatomic axis of the pedicle. In regards to surgeon feedback, all screws could be inserted using standard surgical technique with proprioceptive feedback similar to that of the standard screw. A rotational weakness of the window screw was noted.

Expansion was successful in all cases. For the helical screws, the distal helix expanded fully after twenty revolutions of the inner screw to a maximum diameter of 10mm as measured post extraction. This expansion occurred primary around the junction between the pedicle and the vertebral body with some variability existing in the shape of the expansion with the screws expanding both symmetrically and asymmetrically. The same was true for the central screw, despite more proximal position of the helix, the helix expanded primarily around the area of the body-pedicle junction with a maximal diameter of expansion being approximately 10mm. In the case of the fully helical screw, full expansion occurred after 20 revolutions of the inner screw to a maximum diameter of 10mm. Despite the extension of the helix into the pedicle, very little expansion occurred within the pedicle with the maximum diameter of expansion occurring at the body pedicle junction similar to the other screw designs. The total expansion was limited by lack of threading on the inner screw. Therefore, further expansion was possible and safe and only limited by amount of screw threading. The maximum expansion of the Window screw was 8.5mm, which occurred at a distance of 30mm from the head of the screw. All the window screws expanded successfully; however, the creation of the window had resulted in decreased rotational rigidity of the screw to a point that some plastic deformity occurred in the screws during insertion. This was primarily a twisting deformity, but did not affect screw expansion or result in the screw breakage.

During pull-out testing the majority of the screws failed at the screw-bone (in this case, screw foam) interface. Essentially, the threads that cut into the bone during

insertion fractured, allowing for the screw to slip out. In exception, 2 out of the 5 distal helical screws failed due to screw fracture at the junction of the proximal end of the helix (near the head) and the solid screw.

The highest mean ultimate failure load of 989 N was found in the complete helix screw (Figure 13). The second largest value occurred in the central helix, which had mean ultimate failure load of 941 N. The Distal Helix, Window Screw and Xia screw had mean ultimate failure loads of 910 N, 849 N and 924 N, respectively. These values were not significantly different from one another ($p > 0.05$) (Table 2).

3.2 CADAVERIC TESTING

Based on observations from the Sawbones testing, the inner core threads of the complete helix were extended an additional 5mm allowing for 10 more revolutions if needed. The specifications listed in Section 2.1.1, are for this final design, being 25mm of threading at the end of the inner screw.

The average bone density of the 3 specimens was 97 mg/cm³ (Samples: 75 year old female; 95 year old female; 72 year old female). The CT scans obtained from the specimens did not demonstrate any bony abnormalities or fracture.

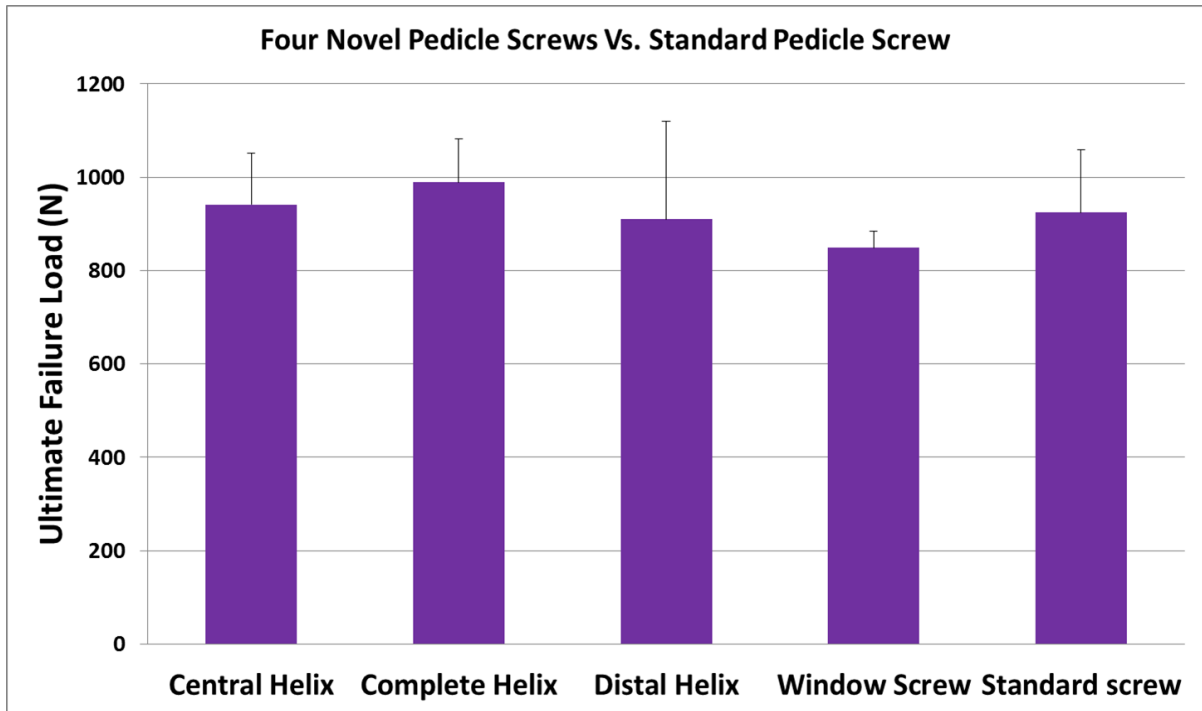

Figure 13: Mean Ultimate failure load of four novel and one standard screw

Graph comparing mean ultimate failure load of all four designs and the standard screw as tested in sawbones. Error bars indicate standard deviation. No significant difference was found between the screws ($p > 0.05$).

	Central Helix	Complete Helix	Distal Helix	Window Screw	Xia
Ultimate Failure Load (N)	973.1	1078.5	777.1	806.0	1042.5
	821.4	1047.7	1114.5	840.7	798.3
	1081.1	953.8	704.4	827.8	888.8
	995.0	883.0	1065.7	880.5	1040.0
	833.0	980.8	890.5	888.3	854.2
Mean	940.7	988.8	910.4	848.7	924.8
Standard Deviation	111.3	77.4	177.7	35.0	111.1

Table 2: Ultimate failure load values for all 4 prototypes and Standard Screw

This table demonstrates the mean ultimate failure load of the four prototypes and the standard screw as tested in Sawbone® specimens. Five tests were performed in each case.

During insertion of the expandable screws and standard screws, no fractures occurred and x-rays post insertion confirmed appropriate screw placement and expansion. In every case, the expandable screw expanded successfully with a maximum expansion of 11mm. The majority of the expansion occurred at the pedicle-body junction and, despite the screw being fully helical, very little expansion (on average less than 1mm) occurred within the pedicle itself. Screw expansion did not result in any fractures. In two cases (*i.e.* L2 of Specimen 1 and T12 of Specimen 2), the testing resulting in failure of potting and therefore these specimens were excluded from the study. The potting failure occurred at the specimen cement interface in both cases and prior to any obvious screw loosening.

For the standard screws, failure occurred at the screw-bone interface with the inner threads of the pedicle stripping, resulting pull out of the screw. In the case of the expandable screws, the majority of the failures (13/16) were due to failure of the screw-bone interface. However, in 3 specimens, failure occurred due to fracture of the pedicle. These fractures extended from the lateral wall of the pedicle to the medial wall of the pedicle and exited through the lateral aspect of the lamina. These fractures did not affect the contralateral pedicle or vertebral body.

Figure 14 shows a representative load-displacement curve, from which ultimate load, energy to peak, total energy, yield and stiffness were calculated. Tabulated data for all specimens is shown in Tables 3 and 4. The mean ultimate failure loads were 623N and 656N for the standard and expandable screw, respectively (Figure 15). The standard deviation was 277 for the standard screw and 250 for the expandable group. These values were not significantly different ($p=0.73$). Mean energy to peak load was 21360 Nmm for the standard screw and 33401 Nmm for the expandable screw (Figure 16) ($p = 0.1$). Mean total energy was calculated to be 34463Nmm and 53943Nmm for the standard and expandable screw, respectively (Figure 17). This represents a 36% increase in energy favoring the expandable screws ($p=0.02$). Stiffness values for both groups were similar ($p=.89$) (Figure 18). For the standard screw, mean stiffness was measured at 224 N/mm, while in the expandable screws it was 238 N/mm. The yield load value were also the same between two groups ($p=0.25$) (Figure 19). The standard screws had yield

value of 380 N/mm and the expandable group had a yield value of 484 N/mm (Table 3.1 and 3.2).

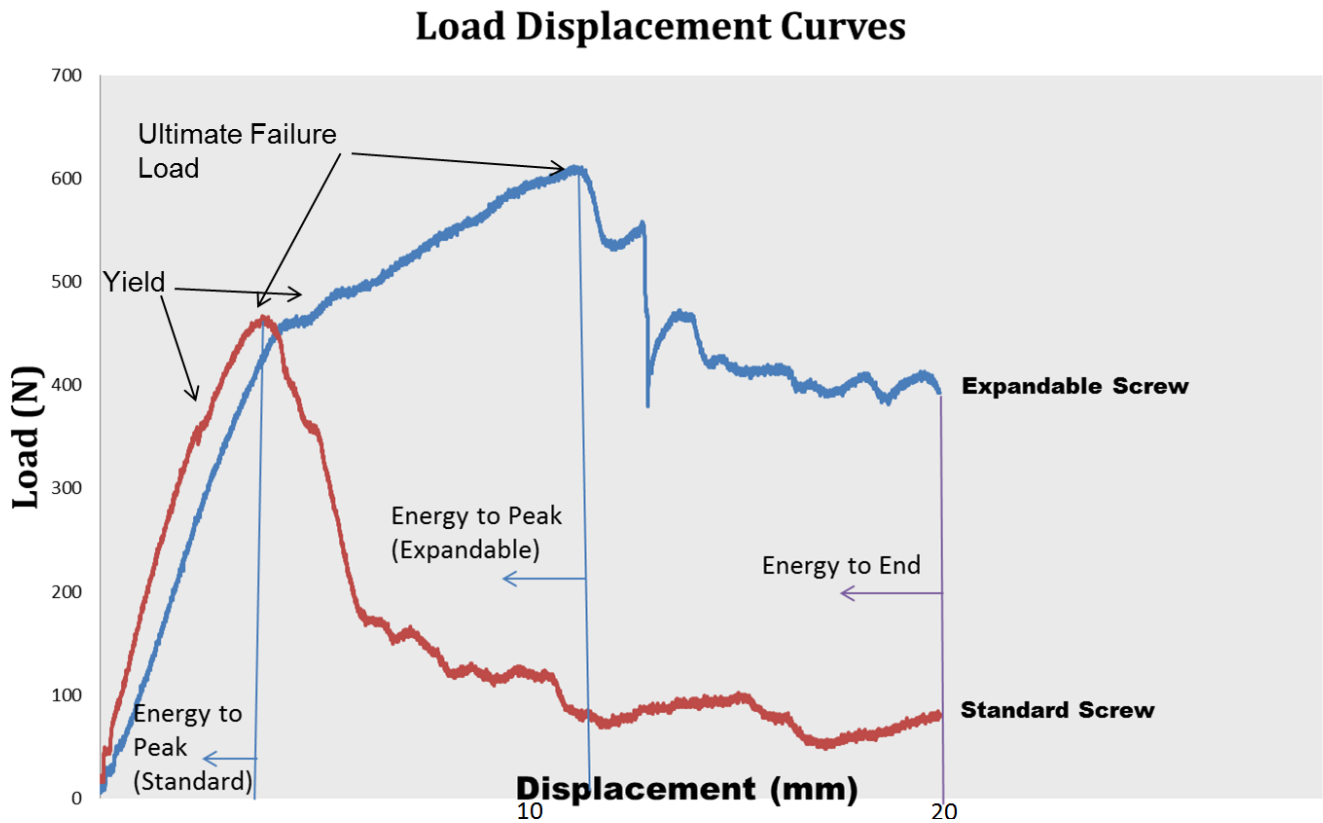

Figure 14: Sample Load Displacement Curve

Load displacement curves for the expandable screw and standard screw in L4 of Specimen 1 are shown as a representative sample. The ultimate failure load, yield point, energy to peak and energy to end are labeled.

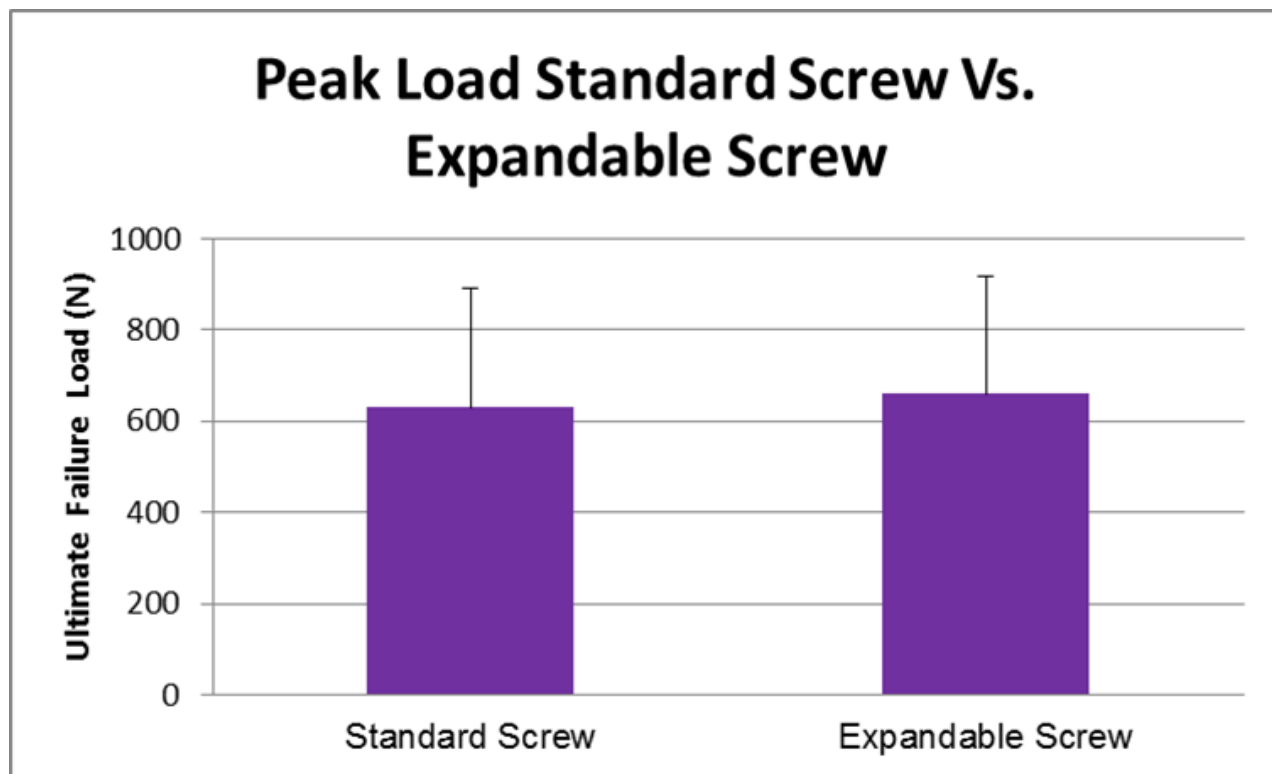

Figure 15: Mean ultimate failure load of standard screw vs. expandable screw

This graph compares the ultimate failure load of a standard screw vs. the fully helical expandable screw as tested in the cadaveric specimens. The Standard screws had a mean ultimate failure of 623 N with a standard deviation of 250 (shown as error bar). The expandable screw had a mean ultimate failure load of 656 with a standard deviation of 277. These values are not statistically different.

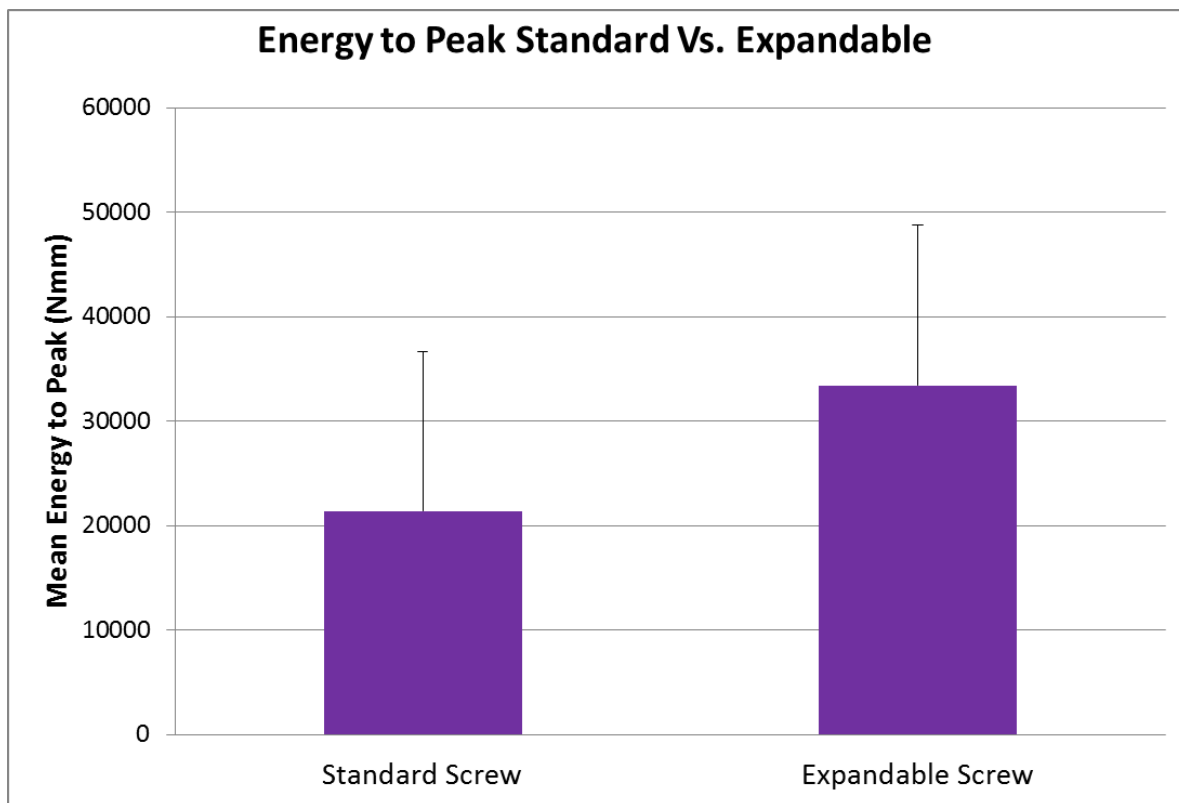

Figure 16: Mean energy to peak load of standard screw vs. expandable screw

This graph compares the mean total mean energy to peak of the standard screws vs. the fully helical expandable screws as tested in cadaveric specimens. The standard screws had mean energy of 21360 Nmm vs. 33401 Nmm for the expandable screw. The error bars indicate the standard deviation. These values are not statistically different.

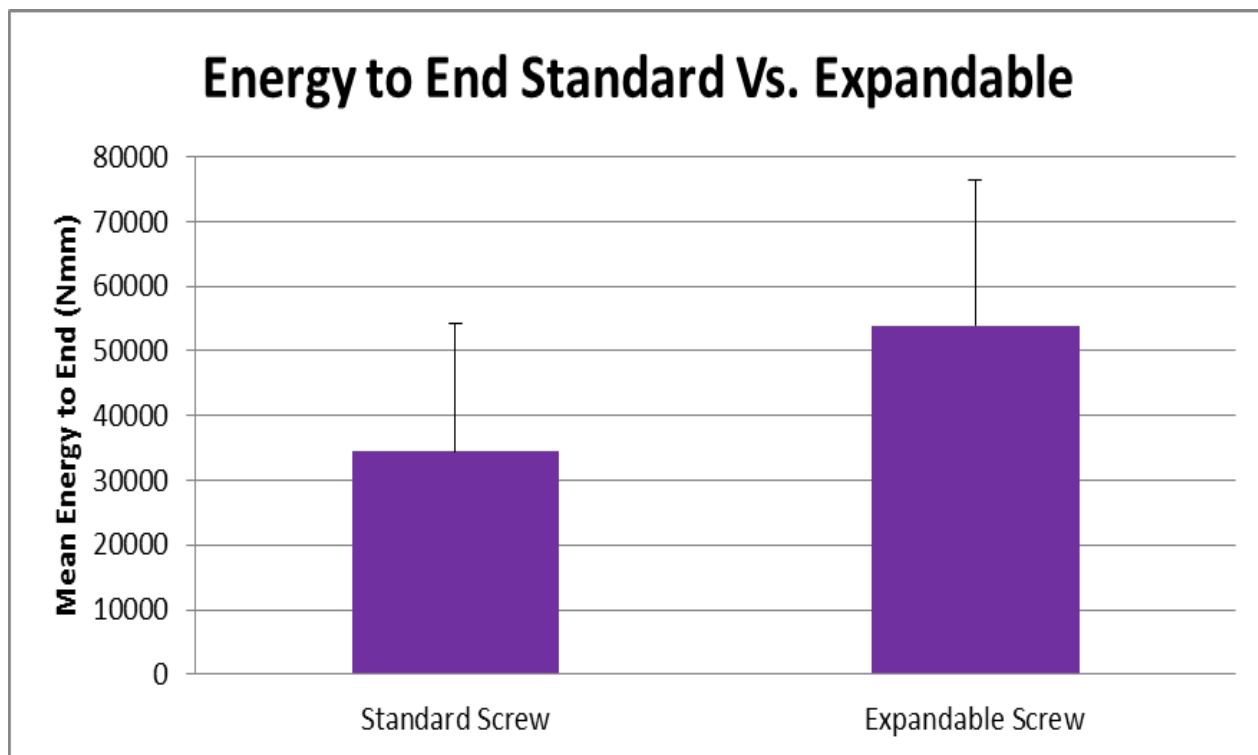

Figure 17: Mean total energy of standard screw vs. expandable screw

This graph compares the mean total energy until the end of the pull-out test for the fully helical expandable screw vs. the standard screw as tested in cadaveric specimens. The expandable helical screw resulted in 36% increase in energy. The standard screws had mean total energy of 34462 Nmm vs. 53943 Nmm in the expandable screws. These values are significantly different ($p = 0.02$).

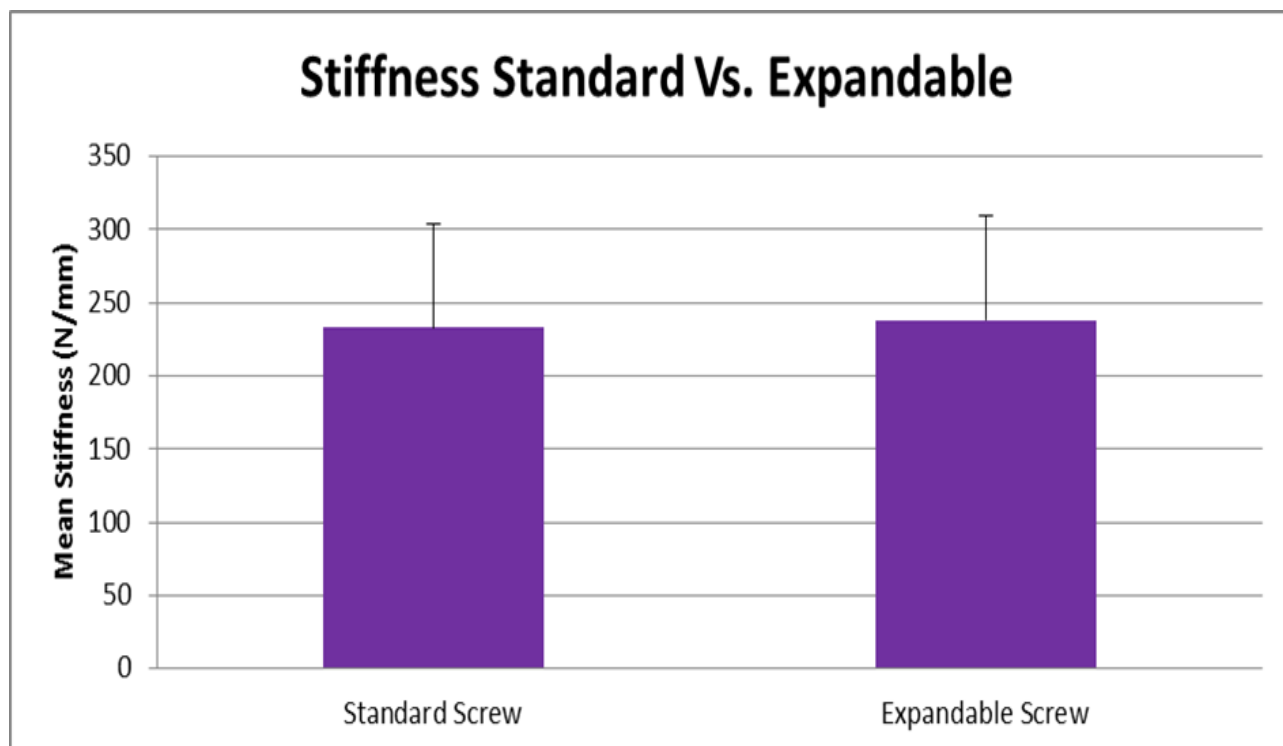

Figure 18: Mean stiffness of standard screw versus the expandable screws

This graph demonstrates mean stiffness values for the standard and the fully helical expandable screws as tested in cadaveric specimens. The standard screw had a mean value of 224N/mm while the expandable screw had a value of 238 N/mm. The error bars indicate standard deviation values. No significant difference was found.

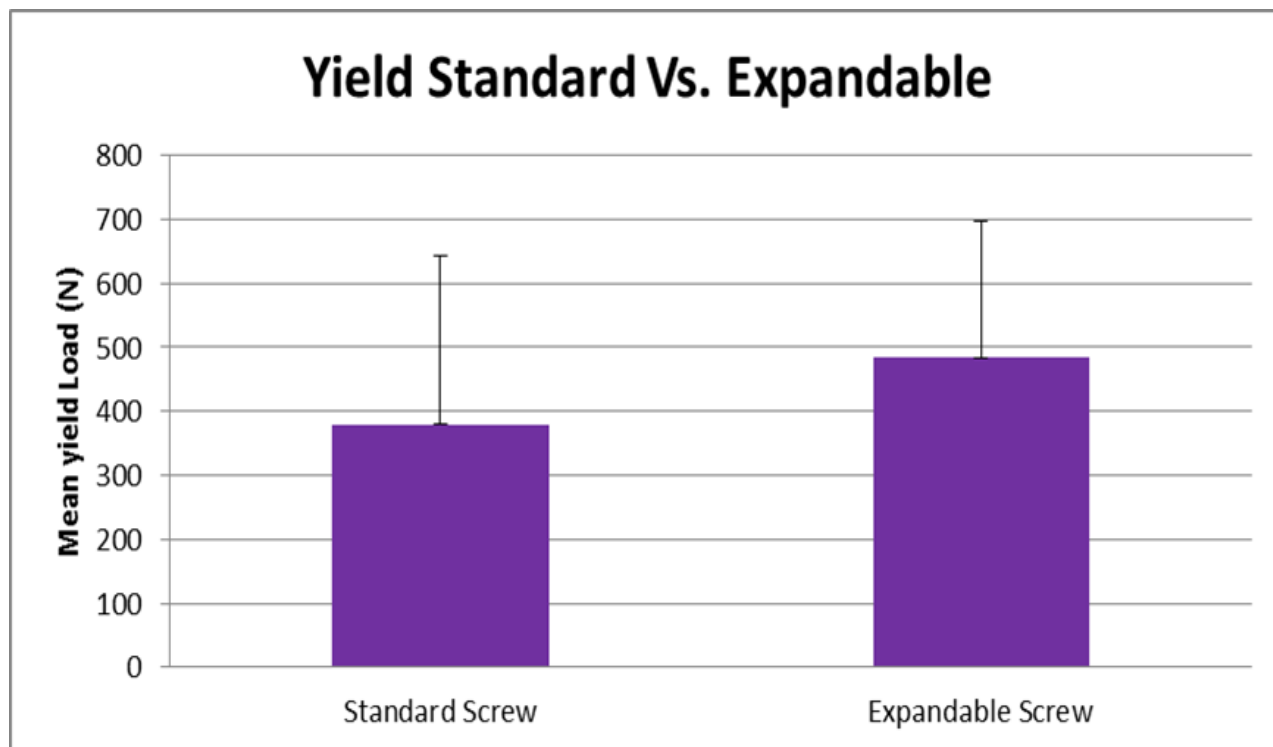

Figure 19: Mean yield values for the standard screw versus expandable screws

This graph demonstrates the mean yield values of the standard screw versus the fully helical expandable screws as tested in cadaveric specimens. The mean yield value for the standard screw was 380 N and for the expandable screw it was 484 N. The error bars indicate standard deviation. No significance difference was found between these values.

Specimen	Level	Ultimate Load (N)	Energy to Peak (Nmm)	Energy to End (Nmm)	Stiffness (N/mm)	Yield (N)
1	T12	819.0	19270.0	34997.3	273.0	176.0
	L1	727.0	15489.0	28441.0	243.2	720.4
	L2					
	L3	1014.8	42378.9	64625.1	281.0	878.5
	L4	764.1	22835.0	46311.4	236.6	606.0
	L5	1237.2	65742.4	88241.0	255.4	809.1
2	T12					
	L1	735.9	22232.9	49077.8	371.3	208.8
	L2	467.2	6646.7	19511.4	365.3	350.2
	L3	408.0	8135.9	17283.5	168.5	373.3
	L4	311.6	21300.0	14009.2	126.2	116.2
	L5	577.7	13863.2	26512.5	211.3	171.5
3	T12	225.5	21420.0	12556.2	250.3	197.2
	L1	747.4	22249.6	42038.4	211.2	706.3
	L2	724.3	23686.2	36378.4	274.5	86.7
	L3	402.9	8301.4	19526.4	155.3	355.3
	L4	361.8	6760.2	15361.8	114.4	229.3
	L5	562.0	21450.5	36531.9	187.8	91.8
Mean		630.4	21360.1	34462.7	232.8	379.8
STDV		260.5	14341.4	19883.7	71.5	264.2

Table 3: Data for testing of the standard screws in Cadaveric specimens

This table demonstrates the collective data for all testing in cadaveric specimens including all 3 specimens for the standard screws. Ultimate failure load, energy to peak, energy to end, yield and stiffness values are shown.

Specimen	Level	Ultimate Load (N)	Energy to Peak (Nmm)	Energy to End (Nmm)	Stiffness (N/mm)	Yield (N)
1	T12	732.0	22410.0	62382.2	217.0	704.0
	L1	667.7	49280.1	59472.2	187.9	477.5
	L2					
	L3	690.9	60782.7	60804.8	281.0	323.2
	L4	1313.1	57124.6	87646.8	359.4	1041.8
	L5	936.4	44327.3	76324.0	255.4	666.4
2	T12					
	L1	654.9	12936.0	91423.5	371.3	606.0
	L2	467.2	33802.0	19511.0	371.3	350.2
	L3	385.7	27723.7	33096.8	168.5	242.2
	L4	640.0	33000.5	53643.3	228.0	480.7
	L5	387.5	9073.2	37344.6	199.0	262.8
3	T12	500.6	9379.6	33236.0	221.5	492.9
	L1	1049.5	71379.3	81402.0	200.0	505.7
	L2	401.6	20160.7	26480.5	160.6	147.1
	L3	554.6	20231.6	43071.9	210.8	458.2
	L4	462.0	10868.5	34381.0	187.8	436.7
	L5	711.4	51945.5	62871.6	192.5	544.3
Mean		659.7	33401.6	53943.3	238.2	483.7
STDV		249.1	19474.1	21799.9	68.4	206.1

Table 4: Data for testing of the Helical screws in Cadaveric specimens

This table demonstrates the collective data for all testing in cadaveric specimens including all 3 specimens for the Helical screws. Ultimate failure load, energy to peak, energy to end, yield and stiffness values are shown.

CHAPTER 4: SUMMARY AND DISCUSSION

In the surgical treatment of spinal disease, pedicle screws represent the gold standard of fixation in the thoracic and lumbar spine [5]. Their presence has substantially changed the surgical treatment of a wide variety of spinal disease, including but not limited to, degenerative, traumatic, deformity and cancer-related diseases. In most cases, the stability and screw purchase obtained with pedicle screws is sufficient to manage patients with spinal pathology. However, in cases of osteoporosis, severe trauma or revision surgery, the current pedicle screw represents a significant limitation, as it cannot provide sufficient bony purchase and can lead to early failure. This failure can have catastrophic outcomes for the patient and represent a grave challenge to the surgeon.

For patients who have had severe trauma to their spine, current instrumentations are not strong enough to maintain the patients' alignment. As such, patients must often undergo further surgery, such as reconstruction of the anterior spinal column, to achieve sufficiently stability [87]. Improving a posterior construct to withstand progressive deformity secondary to the instability resulting from the trauma would limit the need for a second, larger anterior procedure.

The treatment of patients with osteoporosis is an even more significant problem. In the face of osteoporosis, pedicle screws have substantially decreased insertional torque, pull-out strength and toggle strength [39, 41, 88]. Osteoporosis is associated with high rates of early and late instrumentation related failure, and is a major challenge and cost to our health care system [43]. For example, one study demonstrated a 13% early complication rate and a 26% late complication rate directly related to inadequate fixation including pedicle fractures, compression fractures, pseudoarthrosis and progressive deformity [36]. Surgeons face severe limitations in treating osteoporotic patients with spinal instrumentation due to the tendency for these to fail secondary to pullout and subsidence. Often the surgeon is forced to rely on multilevel instrumentation to establish multiple points of fixation [36]. This requires longer procedures with increase complication rates in patients already compromised by age related co-morbidities [42]. Some surgeons advocate the use of cement to improve fixation in osteoporotic patients.

While this can increase pull-out strength of a standard screw, it is not an ideal solution [44]. Once a screw is cemented into position, the removal results in injury to the entire vertebral body. Furthermore, the cement is injected in a liquefied state and can easily penetrate into the canal, potentially causing irreversible nerve injury [4, 48]. Other groups have recommended routine bone mineral density testing in all patients who are at risk of osteoporosis. Even if osteoporosis is identified, however, few surgical options exist to help compensate for the osteoporotic bone [41]. Another option recommended for the treatment of osteoporotic patients is the use of larger diameter screws. Although increase screw diameter in normal bone results in increased pullout strength, this does not appear to be a valid option in the osteoporotic case as a few published reports have found them to be ineffective [49, 89]. Regardless, screw diameter is limited by pedicle canal size, and using larger diameter screws increase the risk of pedicle fracture.

Since the original conception of the pedicle screw, researchers have investigated multiple screw shapes and thread patterns in order to achieve better screw fixation. It is well established that a screw with a conical minor diameter and “V” shaped threads with a pitch of 2.8 mm provide the best form of fixation in both osteoporotic and normal bone [46, 51, 55, 56]. However, standard, commercially available pedicle screws, such as the Xia® screw distributed by Stryker®, which take advantage of these design elements, remain insufficient in the treatment of a patient with poor quality bone. Furthermore, utilization of a conical minor diameter is associated with decreased pull-out strength if the screw is backed up [58]. The backing up of a screw is not an infrequent event in the operation room and is required in cases where the connecting bar will not match with the adjacent screw due to height inequality or simply if the screw is placed deeper than initially planned.

Other authors have attempted to increase pull-out strength of the pedicle screw by modifying the methods by which the screw hole is prepared or the angle at which the screw is placed. It appears that the method of the preparation makes little difference in overall pullout strength and that a screw placed horizontally will be stronger than one placed along the anatomic axis of the pedicle [68, 70, 90]. As such, for our screw hole preparation we used a technique similar to that utilized intraoperatively with the screw

placed along the anatomic axis of the pedicle. However, unlike the standard operative technique, we did utilize a Dremel® work station to drill a pilot hole in order to standardize the angle of insertion. As this pilot hole only measured 2.5mm in diameter, we do not believe it is likely to influence outcome.

In an attempt to address the deficiency of a pedicle screw for use in osteoporotic bone or in cases of revision surgery, several investigators have attempted to design and produce expandable pedicle screws with some success. The majority of these screws expand within the vertebral body post insertion. Most have reported a 30% increase in mean pullout strength as well as safe applications of this technology *in-vivo* [35, 81-85]. However, little clinical data exist today to support the efficacy or safety of these devices. An example of such a device not yet available for use in North America is the OsseoScrew-Zodiac® (Alphatec Spine Inc, Carlsbad, CA). This screw is an expandable titanium screw marketed for use in osteoporosis. Short term clinical data and *in-vitro* biomechanical studies have been performed on this device. The biomechanical studies do demonstrate a 30% increase in ultimate failure load as compared to standard screw.

Our team was able to design and build a novel expanding screw on a recently acquired advanced SLM. Utilizing a rapid prototype machine allowed our team to design and test multiple designs making modifications quickly and effectively as they were needed in a timely manner. Furthermore, use of this device eliminated the need for expensive specialized machining techniques that would have otherwise made this project financially non-feasible. We also build our standard screws on this machine for the purposes of testing and comparison. This was done primarily due to two factors. Firstly, screws build on the SLM have a rough finish equivalent approximately to that of 80 grit sand paper. This high friction surface would likely influence pull-out strength and become a confounding factor. Secondly, the SLMs capability was restricted to use of 316L stainless steel, a material with higher modulus of elasticity than Titanium Alloy used to build the standard pedicle screws.

We tested this device initially in sawbones. These models, which include both the outer cortical shell and inner cancellous bone, are designed with accurate anatomy as well

as material properties to mimic real human bone in a standardized, repeatable manner. Moreover, they are less expensive with fewer restrictions for use, storage and disposal than cadaveric specimens making them an ideal product for preliminary testing.

Although we build four different prototypes, ultimately, the higher pullout strength of the Fully Helical Screw, as well as, its ability to expand more than the other designs lead to its selection for further development and cadaveric testing. It was the fully helical screw that was further tested in osteoporotic human vertebra. The helical screw design described in this thesis successfully meet the majority of the objectives and parameters set out by the design team: 1) expanded *in-vitro*, 2) expanded at the pedicle body junction in all specimens despite size of pedicle or vertebral body, 3) expanded without fracturing the pedicle or vertebral body. Furthermore, it used previously established design parameters for pedicle screw manufacturing with the exception of a conical inner diameter. Due to the complexity of the design, it was not possible to incorporate a conical inner diameter without sacrificing wall thickness substantially. None-the-less, the goal of reaching a 50% increase in ultimate failure load was not achieved.

In regards to ultimate load, the helical expandable screw was no better than a standard screw. This finding was unexpected, as the increased diameter of the screw and the buttressing effect at the pedicle body junction was thought to increase pull out strength. However, it appears that current screw designs are likely utilizing the fixation ability of the pedicle to its full capacity. Furthermore, the expandable pedicle screw was associated with a greater number of pedicle fractures (during pull-out) suggesting that pedicle fixation is maximized with the use of standard screw design. Although it is difficult to know the exact reason and mechanism behind these fractures, it is likely that in some pedicles the expanded screw gains a full buttress fit against the cortex making it impossible for the screw to pull-out without a fracture. It would be useful for future studies to consider pull-out testing under live fluoroscopy to better characterize this mode of failure. As such, despite successful expansion of this design, an increase in pull-out was not detected. Furthermore, expansion of this design requires proximal retraction of

previous threads; this in turn results in stripping of some bone threads made during initial screw insertion resulting in some loss of fixation..

The yield point of this device was also the same as the standard screw. This was an expected finding. In the case bone screws, the bone is substantially softer than the screw despite the type of metal used. As such, the yield point test is really that of bone and not screw and as such not likely to be altered substantially by screw design. In the same manner stiffness was also similar between both groups.

Although both values for energy to peak and energy to pull-out completion were increased by 36%, only the value for total energy reached significance. It is suspected that with a larger number of specimens tested, both of these values would likely be statistically different. The pattern of the load displacement curves suggests that this is as a result of the expandable screws ability to hold the peak load for a longer period of time. The clinical implication of this is currently unknown; however, it is reasonable to conclude that a construct with expandable screws *in-vivo* would take longer to fail when compared to the standard screw if exposed to the same loads.

In regards to other pedicle screw design options considered, 2 out of the 5 distal helical screws failed due to screw fracture at the junction of the proximal end of the helix (near the head) and the solid screw. Therefore, this may be an area of force concentration which causes the weakened junction between helical and non helical part of the shell to break. On the other hand, the window screw was deemed to be a non-feasible option as the creation of the windows resulted in substantial rotational weakening of the screw making it susceptible to deformity with minimal torsional force.

Nonetheless, the goal of achieving a greater than 50% increase in peak load was not reached despite meeting all of the initially determined design parameters. These data provide essential ground work for future design considerations and approaches in development of spinal instrumentation for treatment of osteoporotic or otherwise compromised bone.

CHAPTER 5: FUTURE DIRECTIONS AND LIMITATIONS

When testing any new surgical instrumentation, a major consideration is the realization and reproduction of a realistic mechanism of failure *in-vivo*. The testing method employed in this study, followed standards of testing outline by American Society for Testing and Materials (ASTM) for bone screws. However, axial screw pull-out only represents one possible method of screw failure. In reality, a toggle mechanism is likely to be involved in failure of screws *in-vivo*. As such it is critical that all new designs be tested not only for screw pull-out but also for fatigue failure and toggle failure [91, 92]. In that regard, fatigue testing and toggle testing of this screw are likely to provide further information as to the clinical applicability of an expandable pedicle screw.

Any replacement of the current pedicle screw should increase pullout strength and overall construct strength by more than 50%. This is because any new device will be associated with increased monetary cost as well as potential complication rates especially during its initial introduction. As such, moderate increases in bone purchase would not justify an entirely new device. Furthermore, this device should be made to accommodate current existing spinal instrumentation systems as much as possible to reduce cost and also decrease the amount of training required by surgeons and the operating room staff.

The ideal implant would meet the criteria of: 1) substantially increasing the mechanical properties of fixation, 2) be implantable using standard surgical techniques, 3) be compatible with existing spinal instrumentations systems, 4) be removable without causing extensive bone injury, 5) not expose patient to additional risks, 6) be easy to use by the surgeon, and 7) be relatively inexpensive. In order to achieve these goals, researchers need to “think outside the box”. It is likely that experimentations with other materials will be needed as the expansion and elastic properties of metals such as titanium and stainless steel are limiting factors in the design and development of instrumentation. Furthermore, this device should utilize greater points of fixation and not rely nearly exclusively on the pedicle. Therefore, other vertebral body structures such as the very strong endplates should be considered as possible points of fixation.

In summary, the devices studied in this thesis were all capable of achieving expansion within the vertebral body and were able to buttress against the pedicle effectively. Furthermore, we were able to establish that an advanced rapid prototype machine could be utilized effectively to manufacture testable models of complex implants. Also, our study demonstrated that an expandable screw could be inserted and expanded safely. However, despite this, the biomechanical properties were not increased to a satisfactory level. There are several possible reasons for this. It is possible that any device which utilizes the pedicle alone as a mode of fixation is not likely to increase pullout strength sufficiently. However, it is also possible that more traditional manufacturing techniques, such as machining from solid, may produce higher quality screws than the SLM which could improve the performance of this device. As such, further investigation and design modifications with special consideration given to exploration of other biocompatible materials, use of alternate manufacturing process and dependents on other points of bony fixation are needed. The experienced gained in this body of work, should help researchers work towards developing a superior mode of spinal instrumentation for treatment of patients with poor quality bone.

REFERENCES

1. Benzel, E.C., *Biomechanics of spine stabilization : principles and clinical practice*. 1995, New York: McGraw-Hill, Health Professions Division. x, 278 p.
2. Zindrick, M.R., et al., *Analysis of the morphometric characteristics of the thoracic and lumbar pedicles*. *Spine (Phila Pa 1976)*, 1987. **12**(2): p. 160-6.
3. Krag, M.H., et al., *An internal fixator for posterior application to short segments of the thoracic, lumbar, or lumbosacral spine. Design and testing*. *Clin Orthop Relat Res*, 1986(203): p. 75-98.
4. Benzel, E.C., *Biomechanics of Spine Stabilization*. 1995: McGRAW-HILL, INC.
5. Gaines, R.W., Jr., *The use of pedicle-screw internal fixation for the operative treatment of spinal disorders*. *J Bone Joint Surg Am*, 2000. **82-A**(10): p. 1458-76.
6. Trent, C.G., *The surgical treatment of lumbar degenerative disc disease*. *J S C Med Assoc*, 2000. **96**(11): p. 454-8.
7. Weinstein, J.N., B.L. Rydevik, and W. Rauschnig, *Anatomic and technical considerations of pedicle screw fixation*. *Clin Orthop Relat Res*, 1992(284): p. 34-46.
8. Zindrick, M.R., et al., *A biomechanical study of intrapeduncular screw fixation in the lumbosacral spine*. *Clin Orthop Relat Res*, 1986(203): p. 99-112.
9. Hadra, B.E., *Wiring the spinous processes in Pott's disease*. *Trans. Am. Orthop. Assn.*, 1891. **4**: p. 206.
10. Schlicke, L.H. and D.J. Schulak, *Wiring of the cervical spinous processes*. *Clin Orthop Relat Res*, 1981(154): p. 319-20.
11. King, D., *Internal fixation for lumbosacral fusion*. *J Bone Joint Surg Am*, 1948. **30A**(3): p. 560-5.
12. Boucher, H.H., *A method of spinal fusion*. *J Bone Joint Surg Br*, 1959. **41-B**(2): p. 248-59.
13. Harrington, P.R. and H.S. Tullos, *Reduction of severe spondylolisthesis in children*. *South Med J*, 1969. **62**(1): p. 1-7.
14. Steffee, A.D., R.S. Biscup, and D.J. Sitkowski, *Segmental spine plates with pedicle screw fixation. A new internal fixation device for disorders of the lumbar and thoracolumbar spine*. *Clin Orthop Relat Res*, 1986(203): p. 45-53.

15. Barr, S.J., A.M. Schuette, and J.B. Emans, *Lumbar pedicle screws versus hooks. Results in double major curves in adolescent idiopathic scoliosis*. Spine (Phila Pa 1976), 1997. **22**(12): p. 1369-79.
16. Devlin, V.J., et al., *Treatment of adult spinal deformity with fusion to the sacrum using CD instrumentation*. J Spinal Disord, 1991. **4**(1): p. 1-14.
17. Marchesi, D.G. and M. Aebi, *Pedicle fixation devices in the treatment of adult lumbar scoliosis*. Spine (Phila Pa 1976), 1992. **17**(8 Suppl): p. S304-9.
18. Benzel, E.C. and N.G. Baldwin, *Crossed-screw fixation of the unstable thoracic and lumbar spine*. J Neurosurg, 1995. **82**(1): p. 11-6.
19. Kramer, D.L., W.B. Rodgers, and F.L. Mansfield, *Transpedicular instrumentation and short-segment fusion of thoracolumbar fractures: a prospective study using a single instrumentation system*. J Orthop Trauma, 1995. **9**(6): p. 499-506.
20. Sasso, R.C. and H.B. Cotler, *Posterior instrumentation and fusion for unstable fractures and fracture-dislocations of the thoracic and lumbar spine. A comparative study of three fixation devices in 70 patients*. Spine (Phila Pa 1976), 1993. **18**(4): p. 450-60.
21. Chang, K.W., *Oligosegmental correction of post-traumatic thoracolumbar angular kyphosis*. Spine (Phila Pa 1976), 1993. **18**(13): p. 1909-15.
22. Wang, Q., et al., *[Management of rigid post-traumatic thoracolumbar kyphosis by simultaneous postero-anterior circumferential releasing and correction with preserved posterior vertebral wall]*. Zhongguo Xiu Fu Chong Jian Wai Ke Za Zhi, 2012. **26**(3): p. 261-5.
23. Wu, S.S., et al., *Management of rigid post-traumatic kyphosis*. Spine (Phila Pa 1976), 1996. **21**(19): p. 2260-6; discussion 2267.
24. Anand, S. and M.S. Butt, *Patients' response to facet joint injection*. Acta Orthop Belg, 2007. **73**(2): p. 230-3.
25. Aota, Y., et al., *Reduction of lumbar spondylolisthesis using a CDI pedicle screw system*. Arch Orthop Trauma Surg, 1995. **114**(4): p. 188-93.
26. Lonner, B.S., *Emerging minimally invasive technologies for the management of scoliosis*. Orthop Clin North Am, 2007. **38**(3): p. 431-40; abstract vii-viii.
27. Park, P. and K.T. Foley, *Minimally invasive transforaminal lumbar interbody fusion with reduction of spondylolisthesis: technique and outcomes after a minimum of 2 years' follow-up*. Neurosurg Focus, 2008. **25**(2): p. E16.

28. Park, P. and F. La Marca, *Combined "hybrid" open and minimally invasive surgical correction of adult thoracolumbar scoliosis: a retrospective cohort study*. Neurosurgery, 2013. **72**(2): p. 151-9.
29. Tender, G.C., L.E. Miller, and J.E. Block, *Percutaneous pedicle screw reduction and axial presacral lumbar interbody fusion for treatment of lumbosacral spondylolisthesis: A case series*. J Med Case Rep, 2011. **5**: p. 454.
30. Abe, E., et al., *Total spondylectomy for primary tumor of the thoracolumbar spine*. Spinal Cord, 2000. **38**(3): p. 146-52.
31. Jonsson, B., et al., *Outcome after limited posterior surgery for thoracic and lumbar spine metastases*. Eur Spine J, 1996. **5**(1): p. 36-44.
32. Bennett, G.J., et al., *An experimental study of lumbar destabilization. Restabilization and bone density*. Spine (Phila Pa 1976), 1997. **22**(13): p. 1448-53.
33. Birkenmaier, C., *Re: Ponnusamy KE, Iyer S, Gupta G, Khanna AJ. Instrumentation of the osteoporotic spine: biomechanical and clinical considerations. Spine J 2011;11:54-63*. Spine J, 2011. **11**(5): p. 460; author reply 460-1.
34. Coe, J.D., et al., *Influence of bone mineral density on the fixation of thoracolumbar implants. A comparative study of transpedicular screws, laminar hooks, and spinous process wires*. Spine (Phila Pa 1976), 1990. **15**(9): p. 902-7.
35. Cook, S.D., et al., *Biomechanical study of pedicle screw fixation in severely osteoporotic bone*. Spine J, 2004. **4**(4): p. 402-8.
36. DeWald, C.J. and T. Stanley, *Instrumentation-related complications of multilevel fusions for adult spinal deformity patients over age 65: surgical considerations and treatment options in patients with poor bone quality*. Spine (Phila Pa 1976), 2006. **31**(19 Suppl): p. S144-51.
37. Gurr, K.R., P.C. McAfee, and C.M. Shih, *Biomechanical analysis of anterior and posterior instrumentation systems after corpectomy. A calf-spine model*. J Bone Joint Surg Am, 1988. **70**(8): p. 1182-91.
38. Gurr, K.R., P.C. McAfee, and C.M. Shih, *Biomechanical analysis of posterior instrumentation systems after decompressive laminectomy. An unstable calf-spine model*. J Bone Joint Surg Am, 1988. **70**(5): p. 680-91.
39. Halvorson, T.L., et al., *Effects of bone mineral density on pedicle screw fixation*. Spine (Phila Pa 1976), 1994. **19**(21): p. 2415-20.
40. Kumano, K., et al., *Pedicle screws and bone mineral density*. Spine (Phila Pa 1976), 1994. **19**(10): p. 1157-61.

41. Okuyama, K., et al., *Stability of transpedicle screwing for the osteoporotic spine. An in vitro study of the mechanical stability.* Spine (Phila Pa 1976), 1993. **18**(15): p. 2240-5.
42. Ponnusamy, K.E., et al., *Instrumentation of the osteoporotic spine: biomechanical and clinical considerations.* Spine J, 2011. **11**(1): p. 54-63.
43. Riggs, B.L. and L.J. Melton, 3rd, *The worldwide problem of osteoporosis: insights afforded by epidemiology.* Bone, 1995. **17**(5 Suppl): p. 505S-511S.
44. Soshi, S., et al., *An experimental study on transpedicular screw fixation in relation to osteoporosis of the lumbar spine.* Spine (Phila Pa 1976), 1991. **16**(11): p. 1335-41.
45. Wittenberg, R.H., et al., *Importance of bone mineral density in instrumented spine fusions.* Spine (Phila Pa 1976), 1991. **16**(6): p. 647-52.
46. Abshire, B.B., et al., *Characteristics of pullout failure in conical and cylindrical pedicle screws after full insertion and back-out.* Spine J, 2001. **1**(6): p. 408-14.
47. Barber, J.W., et al., *Biomechanical study of lumbar pedicle screws: does convergence affect axial pullout strength?* J Spinal Disord, 1998. **11**(3): p. 215-20.
48. Becker, S., et al., *Assessment of different screw augmentation techniques and screw designs in osteoporotic spines.* Eur Spine J, 2008. **17**(11): p. 1462-9.
49. Brantley, A.G., et al., *The effects of pedicle screw fit. An in vitro study.* Spine (Phila Pa 1976), 1994. **19**(15): p. 1752-8.
50. Carson, W.L., et al., *Internal forces and moments in transpedicular spine instrumentation. The effect of pedicle screw angle and transfixation--the 4R-4bar linkage concept.* Spine (Phila Pa 1976), 1990. **15**(9): p. 893-901.
51. Chao, C.K., et al., *Increasing bending strength and pullout strength in conical pedicle screws: biomechanical tests and finite element analyses.* J Spinal Disord Tech, 2008. **21**(2): p. 130-8.
52. Dick, J.C., et al., *Mechanical evaluation of cross-link designs in rigid pedicle screw systems.* Spine (Phila Pa 1976), 1997. **22**(4): p. 370-5.
53. Hart, R., et al., *Mechanical stiffness of segmental versus nonsegmental pedicle screw constructs: the effect of cross-links.* Spine (Phila Pa 1976), 2006. **31**(2): p. E35-8.
54. Inceoglu, S., C. Kilincer, and R.F. McLain, *Screw design alters the effects of stress relaxation on pullout.* Biomed Mater Eng, 2008. **18**(2): p. 53-60.

55. Kim, Y.Y., W.S. Choi, and K.W. Rhyu, *Assessment of pedicle screw pullout strength based on various screw designs and bone densities-an ex vivo biomechanical study*. Spine J, 2012. **12**(2): p. 164-8.
56. Kwok, A.W., et al., *Insertional torque and pull-out strengths of conical and cylindrical pedicle screws in cadaveric bone*. Spine (Phila Pa 1976), 1996. **21**(21): p. 2429-34.
57. Law, M., A.F. Tencer, and P.A. Anderson, *Caudo-cephalad loading of pedicle screws: mechanisms of loosening and methods of augmentation*. Spine (Phila Pa 1976), 1993. **18**(16): p. 2438-43.
58. Lill, C.A., et al., *Comparison of the in vitro holding strengths of conical and cylindrical pedicle screws in a fully inserted setting and backed out 180 degrees*. J Spinal Disord, 2000. **13**(3): p. 259-66.
59. McLachlin, S.D., et al., *Comparative assessment of sacral screw loosening augmented with PMMA versus a calcium triglyceride bone cement*. Spine (Phila Pa 1976), 2011. **36**(11): p. E699-704.
60. McLachlin, S.D., et al., *Comparing the fixation of a novel hollow screw versus a conventional solid screw in human sacra under cyclic loading*. Spine (Phila Pa 1976), 2008. **33**(17): p. 1870-5.
61. McLain, R.F., et al., *Lumbar pedicle screw salvage: pullout testing of three different pedicle screw designs*. J Spinal Disord, 1995. **8**(1): p. 62-8.
62. Mikles, M.R., et al., *Biomechanical study of lumbar pedicle screws in a corpectomy model assessing significance of screw height*. J Spinal Disord Tech, 2004. **17**(4): p. 272-6.
63. Panjabi, M.M., *Biomechanical evaluation of spinal fixation devices: I. A conceptual framework*. Spine (Phila Pa 1976), 1988. **13**(10): p. 1129-34.
64. Panjabi, M.M., et al., *Biomechanical evaluation of spinal fixation devices: II. Stability provided by eight internal fixation devices*. Spine (Phila Pa 1976), 1988. **13**(10): p. 1135-40.
65. Pfeifer, B.A., M.H. Krag, and C. Johnson, *Repair of failed transpedicle screw fixation. A biomechanical study comparing polymethylmethacrylate, milled bone, and matchstick bone reconstruction*. Spine (Phila Pa 1976), 1994. **19**(3): p. 350-3.
66. Phillips, J.H. and B.A. Rahn, *Comparison of compression and torque measurements of self-tapping and pretapped screws*. Plast Reconstr Surg, 1989. **83**(3): p. 447-58.

67. Polly, D.W., Jr., J.R. Orchowski, and R.G. Ellenbogen, *Revision pedicle screws. Bigger, longer shims--what is best?* Spine (Phila Pa 1976), 1998. **23**(12): p. 1374-9.
68. Ronderos, J.F., et al., *Comparative pull-out strength of tapped and untapped pilot holes for bicortical anterior cervical screws.* Spine (Phila Pa 1976), 1997. **22**(2): p. 167-70.
69. Skinner, R., et al., *Experimental pullout testing and comparison of variables in transpedicular screw fixation. A biomechanical study.* Spine (Phila Pa 1976), 1990. **15**(3): p. 195-201.
70. Sterba, W., et al., *Biomechanical analysis of differing pedicle screw insertion angles.* Clin Biomech (Bristol, Avon), 2007. **22**(4): p. 385-91.
71. Suk, K.S., et al., *Unilateral versus bilateral pedicle screw fixation in lumbar spinal fusion.* Spine (Phila Pa 1976), 2000. **25**(14): p. 1843-7.
72. Zdeblick, T.A., et al., *Pedicle screw pullout strength. Correlation with insertional torque.* Spine (Phila Pa 1976), 1993. **18**(12): p. 1673-6.
73. Wittenberg, R.H., et al., *Effect of screw diameter, insertion technique, and bone cement augmentation of pedicular screw fixation strength.* Clin Orthop Relat Res, 1993(296): p. 278-87.
74. McAfee, P.C., et al., *1989 Volvo Award in basic science. Device-related osteoporosis with spinal instrumentation.* Spine (Phila Pa 1976), 1989. **14**(9): p. 919-26.
75. Petersilge, C.A., et al., *Optimizing imaging parameters for MR evaluation of the spine with titanium pedicle screws.* AJR Am J Roentgenol, 1996. **166**(5): p. 1213-8.
76. Uhl, R.L., *The biomechanics of screws.* Orthop Rev, 1989. **18**(12): p. 1302-7.
77. Schatzker, J., J.G. Horne, and G. Sumner-Smith, *The effect of movement on the holding power of screws in bone.* Clin Orthop Relat Res, 1975(111): p. 257-62.
78. Misenhimer, G.R., et al., *Anatomic analysis of pedicle cortical and cancellous diameter as related to screw size.* Spine (Phila Pa 1976), 1989. **14**(4): p. 367-72.
79. Borsari, V., et al., *Osteointegration of titanium and hydroxyapatite rough surfaces in healthy and compromised cortical and trabecular bone: in vivo comparative study on young, aged, and estrogen-deficient sheep.* J Orthop Res, 2007. **25**(9): p. 1250-60.

80. Sotiriadou, S., E. Dielert, and E. Fischer-Brandies, [*The osteointegration of ceramic hydroxyapatite*]. Hell Period Stomat Gnathopathoprosopike Cheir, 1987. **2**(3): p. 101-4.
81. Cook, S.D., et al., *Biomechanical evaluation and preliminary clinical experience with an expansive pedicle screw design*. J Spinal Disord, 2000. **13**(3): p. 230-6.
82. Cook, S.D., et al., *Biomechanical testing and clinical experience with the OMEGA-21 spinal fixation system*. Am J Orthop (Belle Mead NJ), 2001. **30**(5): p. 387-94.
83. Gazzeri, R., R. Roperto, and C. Fiore, *Titanium Expandable Pedicle Screw for the Treatment of Degenerative and Traumatic Spinal Diseases in Osteoporotic Patients: Preliminary Experience*. Surg Technol Int, 2012. **XXII**.
84. Schramm, M., et al., *Anterior vertebral body screw pullout testing with the hollow modular anchorage system--a comparative in vitro study*. Biomed Tech (Berl), 2003. **48**(12): p. 356-61.
85. Vishnubhotla, S., et al., *A titanium expandable pedicle screw improves initial pullout strength as compared with standard pedicle screws*. Spine J, 2011. **11**(8): p. 777-81.
86. Pfeiffer, M., et al., *Effect of specimen fixation method on pullout tests of pedicle screws*. Spine (Phila Pa 1976), 1996. **21**(9): p. 1037-44.
87. Wang, X.Y., et al., *Biomechanical effect of the extent of vertebral body fracture on the thoracolumbar spine with pedicle screw fixation: an in vitro study*. J Clin Neurosci, 2008. **15**(3): p. 286-90.
88. Snider, R.K., *A prospective, randomized study of lumbar fusion: preliminary results*. Spine (Phila Pa 1976), 1994. **19**(1): p. 109.
89. Hirano, T., et al., *Structural characteristics of the pedicle and its role in screw stability*. Spine (Phila Pa 1976), 1997. **22**(21): p. 2504-9; discussion 2510.
90. George, D.C., et al., *Hole preparation techniques for transpedicle screws. Effect on pull-out strength from human cadaveric vertebrae*. Spine (Phila Pa 1976), 1991. **16**(2): p. 181-4.
91. Goel, V.K., J.M. Winterbottom, and J.N. Weinstein, *A method for the fatigue testing of pedicle screw fixation devices*. J Biomech, 1994. **27**(11): p. 1383-8.
92. Wilke, H.J., K. Wenger, and L. Claes, *Testing criteria for spinal implants: recommendations for the standardization of in vitro stability testing of spinal implants*. Eur Spine J, 1998. **7**(2): p. 148-54.

APPENDIX A – GLOSSARY

Anterior: Situated at or directed toward the front; opposite of posterior; refers to the front of the body when in the anatomical position.

Anteromedial: Directed from the front towards the mid-line of the body.

Aorta: The large arterial trunk that carries blood from the heart to be distributed by branch arteries through the body

Arthrodesis: The surgical immobilization of a joint so that the bones grow solidly together.

Articular: Of or relating to a joint.

Atlas: The first vertebra of the neck.

Axis: The second vertebra of the neck.

Bicortical: Passing through two cortical walls.

Bilateral: Affecting the right and left sides of the body or the right and left members of paired organs.

Cancellous Bone: A spongy, lattice-like structure of bone, also known as trabecular bone.

Caudal: Situated in or directed toward the hind; inferior to another structure, in the sense of being below it.

Cervical: The vertebrae immediately beneath (posterior to) the skull and above the thoracic vertebrae.

Coccyx: A small bone that articulates with the sacrum and that usually consists of four fused vertebrae which form the terminus of the spinal column.

Contralateral: Occurring on, affecting, or acting in conjunction with a part on the opposite side of the body.

Cortical Bone: The dense, outer layer of bone; a hard shell surrounding cancellous bone.

Cranial: Directed toward the skull, superior to another structure, in the sense of being above it.

Degenerative: Deterioration of a tissue or an organ in which its vitality is diminished or its structure impaired.

Fusion: The surgical immobilization of a joint.

Graft: To implant (living tissue) surgically.

Implants: Something (as a graft or device) implanted in tissue.

Inferior: In anatomy, used in reference to the lower surface of a structure, or to the lower of two (or more) similar structures.

In Situ: In the natural or original position or place.

In Vitro: In an artificial environment outside the living organism.

In Vivo: Within the living organism.

Kyphosis: Outward curvature of the thoracic region of the spinal column resulting in a rounded upper back.

Lateral: Denoting a position farther from the median plane or mid-line of the body or a structure; refers to being away from the mid-line of the body when in the anatomical position.

Lordotic: Forward curvature of the lumbar and cervical regions of the spinal column.

Lumbar: The vertebrae between the thoracic vertebrae and sacrum.

Medial: Situated towards the mid-line of the body or a structure.

Monocortical: Passing through one cortical wall.

Morphometric: The quantitative measurement of the form especially of living systems or their parts.

Orthopaedics: The branch of surgery dealing with the preservation and restoration of the function of the skeletal system, its articulations, and associated structures.

Osteoporosis: A condition that is characterized by decrease in bone mass with decreased density and enlargement of bone spaces producing porosity and brittleness.

Pathology: The anatomic and physiological deviations from the normal that constitute disease or characterize a particular disease.

Pediatric: A branch of medicine dealing with the development, care, and diseases of children.

Pedicles: Two short pieces of bone that form the lateral sides of the vertebral arch connecting the arch to the vertebral body.

Physiological: In accordance with or characteristic of the normal functioning of a living organism.

Posterior: Directed toward or situated at the back; opposite of anterior; refers to the back of the body when in the anatomical position.

Posterolateral: Posterior and lateral in position or direction

Proximal: Situated next to or near the point of attachment or origin.

Sacral: Region of the spine containing the sacrum and coccyx.

Sacroiliac: The region of the joint between the sacrum and the ilium.

Sacrum: A large, triangular bone formed by five fused vertebrae at the base of the spine; exists below the lumbar region and above the coccyx.

Sagittal plane: Of, relating to, situated in, or being the median plane of the body or any plane parallel to it.

Scoliosis: A lateral curvature of the spine.

Spondylolisthesis: Forward displacement of a lumbar vertebra on the one below it producing pain by compression of nerve roots.

Superior: Situated above, or directed upward.

Thoracic: The vertebrae between the cervical and lumbar vertebrae.

Thoracolumbar: Of, relating to, arising in, or involving the thoracic and lumbar regions.

Trabecular Bone: See Cancellous Bone.

Transverse: Extending from side-to-side; at right angles to the long axis.

Vertebra: The individual, irregular bones that make up the spinal column

APPENDIX B – SUPPLEMENT DESCRIPTION OF HELICAL SCREW

Supplement to Description of Invention

To further clarify the main novelty of this invention and the mechanics causing the expansion, in addition to the previous description, a series of images are shown below to explain how the expansion occurs.

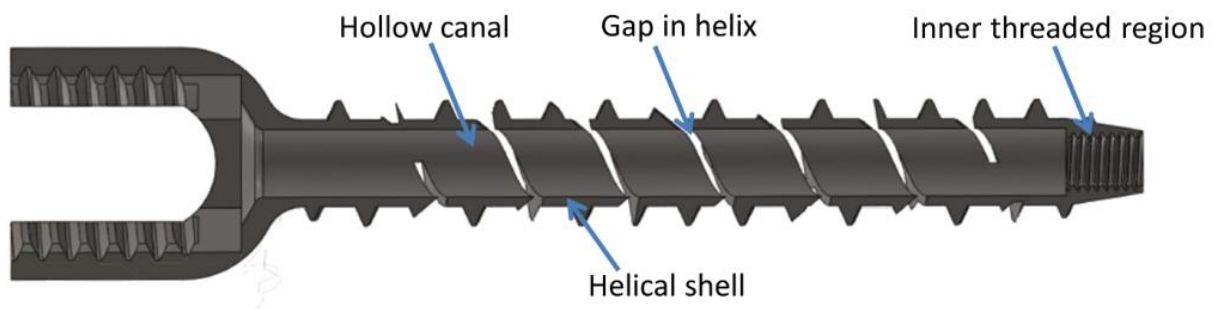

Figure B20: Section View of Helical Shell

The outer shell of the novel expanding screw is designed to have an appearance similar to other pedicle screws, with a long threaded outer surface connected to a bulbous head (on left side of the image). The unique features of this design is the hollow canal running through the screw, the helical shell, and the inner threaded region at the tip of the screw. With the hollow canal, the gaps in the helical shell are visible, making it appear as though the screw consists of many separate pieces. Instead, this is a function of this cross sectional view. The shell of the screw is a helix, similar to a thick spring, with very small gaps between the leading and lagging edges. The final feature of the shell is the threaded inner end of the tip, designed to fit an M3 thread.

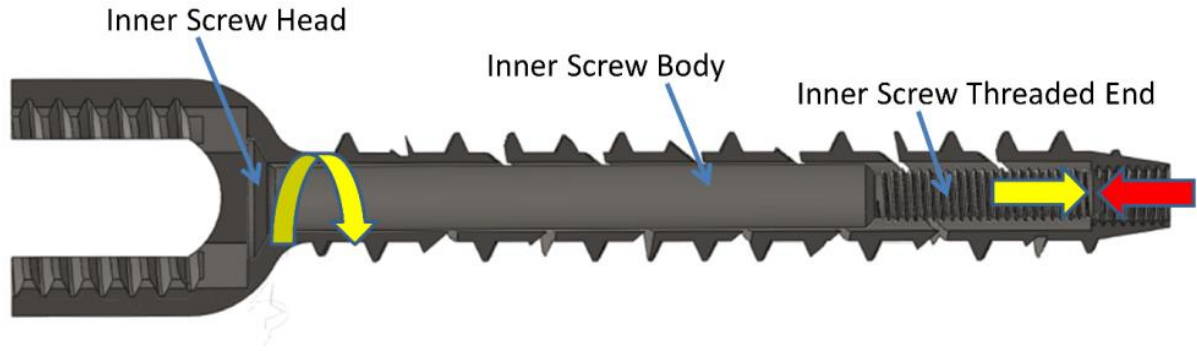

Figure B21: Section View of Helical Shell and Inner Screw at Initial Ingagement

To engage the helical shell, an inner screw is inserted within the hollow canal of the outer shell. The body of the inner screw is sized to fit the width of the canal (clearance fit, not press fit). The end of the inner screw consists of 25mm of M3 thread. The inner screw slides easily into the canal (yellow arrow), until the head of the inner screw cannot proceed further (buttressed by the taper of the outer shell). At this point, the critical action here is that as the inner screw is continually rotated, engaging the threads at the tip of the helical shell (yellow curved arrow). Since the inner screw cannot proceed any further, this rotation instead causes the helical shell to retract towards the head of the screw (red arrow). In other words, the rotation of the innerscrew results in translation and shortening of the shell from its tip.

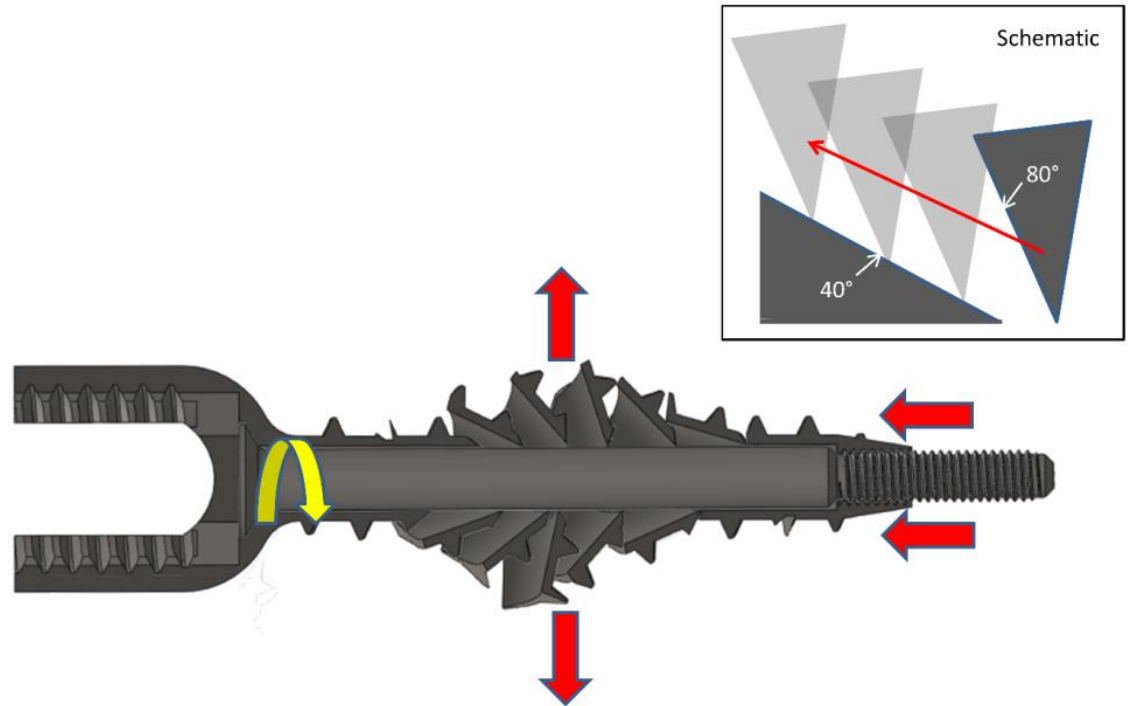
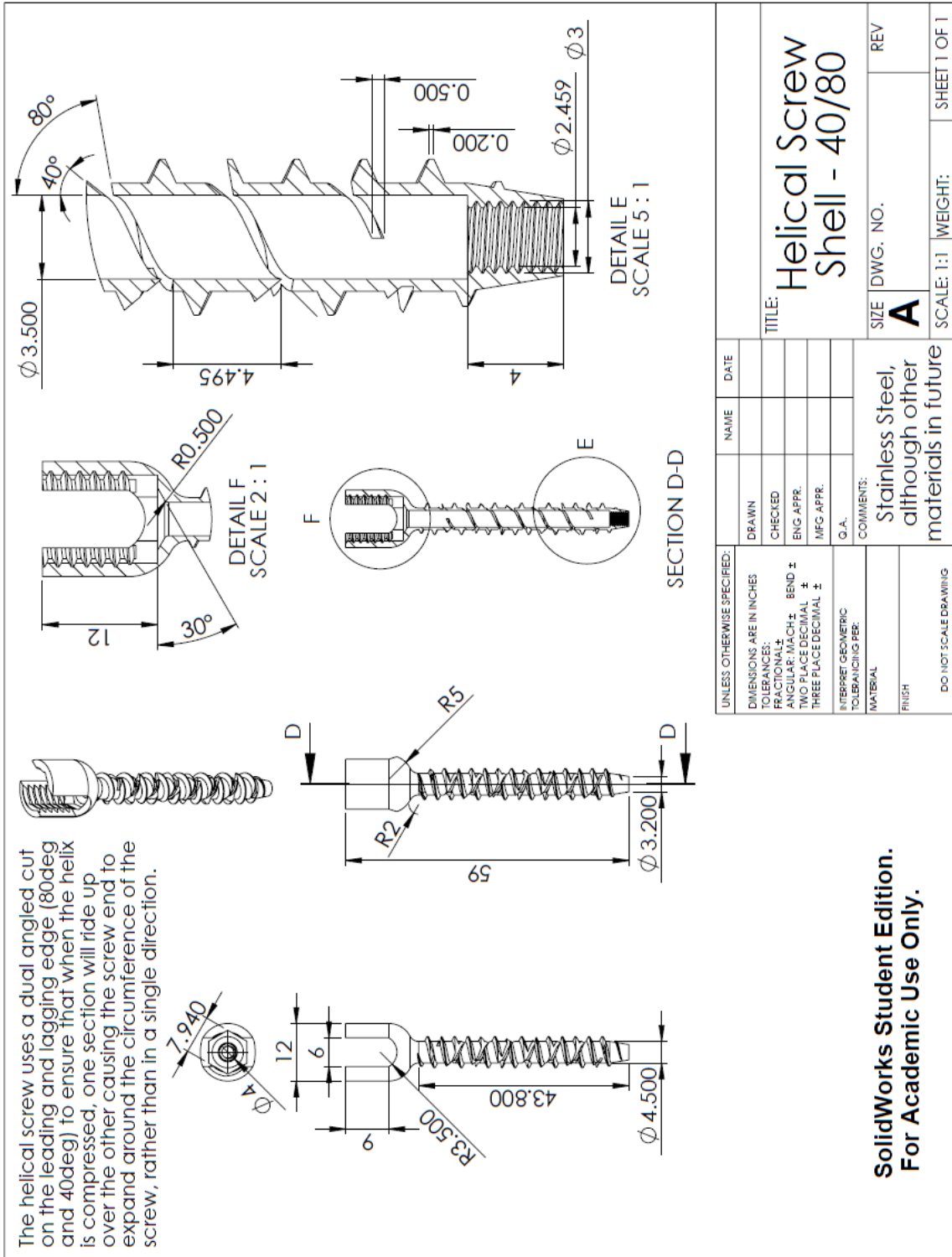

Figure B22: Helical Shell Expansion

As described in Figure 2, the inner screw is continually rotated (yellow curved arrow) until the end of the outer helical shell retracts along the threaded end of the inner screw (red arrows pointing left). The expansion of the helix then begins to occur as the walls of the helix come in contact with each other (red arrows pointing up and down). This expansion phenomenon is shown in the schematic figure where the lagging edge (80° shown) will translate up the leading edge of the next loop of the helix (40° shown) as the helix closes.



Figur B23: Engineering Drawing of Novel Expanding Screw

Dimensions shown are for the original prototype design.

DR. PARHAM RASOULINEJAD

This CV is current as of: 2013-07-29

- **QUALIFICATIONS OBTAINED**
 - **Fellowship Training in Adult Spinal Surgery**
 - *University of Western Ontario (Ontario, Canada)* Jul. 2013
 - **Certified by the Royal College of Surgeons of Canada in Orthopaedic Surgery**
 - *Board certified orthopaedic surgeon* Jun. 2012
 - **Medical Council of Canada Qualifying Exams (MCCQE)**
 - *University of Ottawa (Ontario, Canada)*
 - Step I Nov. 2007
 - Step II Oct. 2009
 - **Doctorate in Medicine**
 - *University of Ottawa* May 2007
 - **Bachelor of Kinesiology, Honours**
 - *University of Western Ontario* Jul. 2003
- **CURRENT POSITION**
 - **Clinical Fellow in Paediatric Spine Surgery**
 - *University of British Columbia, Vancouver, British Columbia*
 - *Department of Paediatric Orthopaedics*
 - *Full time clinical fellow in Paediatric spine surgery with responsibilities including, but not limited to:*
 - Performance of surgery
 - Surgical assistant
 - Patient management: Inpatient, emergency department and clinic
 - Weekend and night on-call duties including, but not limited to orthopaedic trauma and spine surgery
 - Involvement with clinical research
 - Supervision of residents in the operating room and clinic

- **MSc Student in Medical Biophysics**
Sep. 2012
 - *University of Western Ontario, London, Ontario*
 - *Full time masters student in the Department of Medical Biophysics*
 - Attendance of masters level classes
 - Research responsibilities
 - Presentation of research at major meetings
 - Supervision of surgical residents in a biomechanics lab

- **CLINICAL COURSES**

- **Canadian Orthopaedic Residents Trauma Course**
 - Resident review course in trauma surgery
 - Kingston, Ontario

May 2012
- **Saint-Justine Pediatric Orthopaedic Course**
 - Review course in pediatric surgery
 - Montreal, Quebec

Mar. 2012
- **Scientific Conference of Canadian Spine Society**
 - Accredited group leaning and spine meeting
 - Calgary, Canada

Feb. 2012
- **CORR Reconstructive Surgery**
 - Canadian orthopaedic resident review course
 - Toronto, Ontario

Jan. 2012
- **Canadian Orthopaedic Residents Trauma Course**
 - Resident review course in trauma surgery
 - Kingston, Ontario

May 2011
- **Current Concepts in Joint Replacement**
 - International meeting on arthorplasty
 - Orlando, Florida

Dec. 2011
- **CORR Trauma Surgery**
 - Canadian orthopaedic resident review course
 - Toronto, Ontario

Nov. 2011
- **Sport Medicine Symposium**
 - Multidisciplinary meeting on sports medicine
 - London, Ontario

Sep. 2011
- **Resident Leadership Forum**
 - Identified as a top PGY 4 resident

- Boston, Massachusetts
Jun. 2011
- **Masters Shoulder arthroplasty**
 - Canadian Surgical Technologies & Advanced Robotics
 - London, Ontario
May 2011
- **Certificate in Crucial Conversations**
 - Training session on patient interactions
 - London, Ontario
Jul. 2010
- **AAHKS (Arthroplasty) 1st Annual Resident Course**
 - Resident meeting on arthroplasty
 - Dallas, Texas
Oct. 2010
- **AAHKS (Arthroplasty) 19th Annual Meeting**
 - International meeting on arthroplasty
 - Dallas, Texas
Nov. 2010
- **Advanced Trauma Life Support Provider (ATLS)**
 - Complete training in ATLS
 - London, Ontario
Jul. 2007
- **Advanced Cardiac Life Support Provider (ACLS)**
 - Complete training in ACLS
 - London, Ontario
Aug. 2007

- **INTERNSHIP AND RESIDENCY TRAINING**

<i>Internship/Residency Rotations</i>	<i>From</i>	<i>To</i>
Orthopaedic adult reconstruction	Jul 1, 2007	Sep 3, 2007
Traumatology	Sep 4, 2007	Sep 30, 2007
Emergency medicine	Oct 1, 2007	Dec 2, 2007
Plastic & reconstructive surgery	Dec 3, 2007	Jan 1, 2008
Orthopaedic trauma	Jan 2, 2008	Mar 2, 2008
General internal medicine	Mar 3, 2008	Mar 31, 2008
Diagnostic radiology	Apr 1, 2008	Apr 30, 2008
General surgery	May 1, 2008	Jun 30, 2008
Orthopaedic surgery hand and upper Limb	July 1, 2008	Sept 6, 2008
Spine surgery	Sept 7, 2008	Nov 2, 2008
ICU/CCTC	Nov 3, 2008	Nov 30, 2008
Critical Care Trauma Unit	Nov 3, 2008	Jan 4, 2009
Orthopaedic surgery adult reconstruction	Jan 4, 2009	Mar 1, 2009
Physical medicine & rehabilitation	Mar 2, 2009	Mar 31, 2009
Rheumatology	Apr 1, 2009	Apr 30, 2009
Orthopaedic trauma	May 1, 2009	Jun 30, 2009
Cervical spine biomechanics research	Jul 1, 2009	Oct 19, 2009
Orthopaedic sport surgery	Oct 20, 2009	Jan 11, 2010
Orthopaedic adult reconstruction	Jan 12, 2010	Apr 5, 2010
Orthopaedic paediatric surgery	Apr 6, 2010	Jun 30, 2010

Community orthopaedic surgery	Jul 1, 2010	Sep 20, 2010
Musculoskeletal tumour surgery	Sep 21, 2010	Oct 18, 2010
Orthopaedic adult reconstruction	Oct 19, 2010	Jan 10, 2011
Orthopaedic spine surgery	Jan 11, 2011	Apr 4, 2011
Orthopaedic surgery hand and upper Limb	Apr 5, 2011	Jun 30, 2011
Orthopaedic sport surgery	Jul 1, 2011	Oct 24, 2011
Orthopaedic trauma	Oct 25, 2011	Jan 16, 2012
Orthopaedic paediatric surgery	Jan 17, 2012	Apr 9, 2012
Orthopaedic surgery adult reconstruction	Apr 10, 2012	Jun 30, 2012

- **REGISTRATION/CERTIFICATION HISTORY**

- **The College of Physicians and Surgeons of Ontario**

- CPSO No. 86285

Current

- **Ontario Medical Association**

- OMA No. 0883785

Current

- **Canadian Medical Association**

- CMA No. 128819

Current

- **The Canadian Orthopaedic Association**

- Qualified orthopaedic surgeon

Current

- **Medical Council of Canada**

- LMCC No. 108755

Current

- **Australian Medical Council**

- Qualification of Doctor of Medicine
- AMC No. 2114281

Current

- **PUBLICATIONS**

- **Rasoulinejad, P.,** McLachlin, S., Bailey, C., Dunning, C. Sub-axial Cervical Spine Instability following Unilateral Facet Injury: A Biomechanical Analysis.

- *Journal of Spine*

- McLachlin, S., **Rasoulinejad, P.,** Bailey, C., Dunning, C. Anterior versus Posterior Fixation for an Isolated Posterior Facet Injury in the Subaxial Cervical Spine.

- *Submitted for Publication*
- **PODIUM PRESENTATIONS**
 - **Cervical Spine Research Society**

Dec. 2011

 - McLachlin, S., **Rasoulinejad, P.**, McLachlin, S., Bailey, C., Dunning, C. Anterior versus Posterior Fixation for an Isolated Posterior Facet Injury in the Subaxial Cervical Spine. Canadian Orthopaedic Research Society 45th annual meeting. St John, Newfoundland.
 - **Orthopaedic Residents' Research Day**

Oct. 2011

 - **Rasoulinejad, P.**, Kedgley, A, Bailey, C. In-vivo Motion Analysis of the Charite Lumbar Disc Replacement. 39th Clinical Seminar in Orthopaedic Surgery, University of Western Ontario, London, Ontario.
 - **Department of Surgery Research Day**

Jun. 2011

 - **Rasoulinejad, P.**, McLachlin, S., Bailey, C., Dunning, C. Anterior versus Posterior Fixation for an Isolated Posterior Facet Injury in the Subaxial Cervical Spine. London, Ontario.
 - **Orthopaedic Residents' Research Day**

Oct. 2010

 - **Rasoulinejad, P.**, McLachlin, S., Bailey, C., Dunning, C. Anterior versus Posterior Fixation for an Isolated Posterior Facet Injury in the Subaxial Cervical Spine. 38th Clinical Seminar in Orthopaedic Surgery, University of Western Ontario, London, Ontario.
 - **Canadian Spine Society (CSS)**

Mar. 2010

 - **Rasoulinejad, P.**, McLachlin, S., Bailey, C., Dunning, C. Sub-axial Cervical Spine Instability following Unilateral Facet Injury: A Biomechanical Analysis. 10th annual scientific conference of the Canadian Spine Society, Lake Louise, Alberta.
 - **Orthopaedic Residents' Research Day**

Oct. 2009

 - **Rasoulinejad, P.**, McLachlin, S., Bailey, C., Dunning, C. Sub-axial Cervical Spine Instability following Unilateral Facet Injury: A Biomechanical Analysis. 37th Clinical Seminar in Orthopaedic Surgery, University of Western Ontario, London, Ontario.
 -
 - **Orthopaedic Residents' Research Day**

Oct. 2008

 - **Rasoulinejad, P.**, Sanders, D. Hemorrhage in trauma patients with pelvic ring fractures. 36th Clinical Seminar in Orthopaedic Surgery, University of Western Ontario, London, Ontario.

- **POSTER PRESENTATIONS**

- **Cervical Spine Research Society (CSRS)**

Dec. 2011

- **Rasoulinejad, P.**, McLachlin, S., Bailey, C., Dunning, C. Sub-axial Cervical Spine Instability following Unilateral Facet Injury: A Biomechanical Analysis.

- **Canadian Orthopaedic Association (COA)**

Jul. 2011

- McLachlin, S., **Rasoulinejad, P.**, Bailey, C., Dunning, C. Anterior versus Posterior Fixation for an Isolated Posterior Facet Injury in the Subaxial Cervical Spine.

- **Orthopaedic Research Society (ORS)**

Jan. 2011

- **Rasoulinejad, P.**, McLachlin, S., Bailey, C., Dunning, C. Anterior versus Posterior Fixation for an Isolated Posterior Facet Injury in the Subaxial Cervical Spine

- **Orthopaedic Research Society (ORS)**

Jan. 2011

- McLachlin, S., **Rasoulinejad, P.**, Bailey, C., Dunning, C. Anterior versus Posterior Fixation for an Isolated Posterior Facet Injury in the Subaxial Cervical Spine.

- **Canadian Orthopaedic Association (COA)**

Jun. 2010

- **Rasoulinejad, P.**, McLachlin, S., Bailey, C., Dunning, C. Sub-axial Cervical Spine Instability following Unilateral Facet Injury: A Biomechanical Analysis.

- **AWARDS/SCHOLARSHIPS**

- **Ontario Graduate Scholarship (OGS) grant**

Jul. 2013

- University of Western Ontario (London, Ontario)
 - Graduate study Grant (Valued at \$15000.00)
 - Declined due to early completion of study

- **Orthopaedic Research Society (ORS)**

Jan. 2011

- 1st Place basic science research award paper at the 39th Annual Cervical Spine Research Society meeting for:
 - Anterior versus Posterior Fixation for an Isolated Posterior Facet Complex Injury in the Subaxial Cervical Spine.

- **Orthopaedic Residents' Research Day**

Oct. 2010

- 1st Place basic science research award paper for
 - Anterior versus Posterior Fixation for an Isolated Posterior Facet Injury in the Subaxial Cervical Spine. (Valued at \$1000.00)
- **J. Howard Crocker School of Kinesiology Scholarship**Nov. 1999
 - University of Western Ontario (London, Ontario)
 - Faculty Entrance Scholarship (Valued at \$16000.00)

