Electronic Thesis and Dissertation Repository

8-9-2013 12:00 AM

Ionic and Osmotic Mechanisms Of Insect Chill-Coma And Chilling Injury

Heath A. MacMillan
The University of Western Ontario

Supervisor
Dr. Brent J. Sinclair
The University of Western Ontario

Graduate Program in Biology
A thesis submitted in partial fulfillment of the requirements for the degree in Doctor of Philosophy
© Heath A. MacMillan 2013

Follow this and additional works at: <https://ir.lib.uwo.ca/etd>



Part of the [Systems and Integrative Physiology Commons](#)

Recommended Citation

MacMillan, Heath A., "Ionic and Osmotic Mechanisms Of Insect Chill-Coma And Chilling Injury" (2013). *Electronic Thesis and Dissertation Repository*. 1410.
<https://ir.lib.uwo.ca/etd/1410>

This Dissertation/Thesis is brought to you for free and open access by Scholarship@Western. It has been accepted for inclusion in Electronic Thesis and Dissertation Repository by an authorized administrator of Scholarship@Western. For more information, please contact wlsadmin@uwo.ca.

IONIC AND OSMOTIC MECHANISMS OF INSECT CHILL-COMA
AND CHILLING INJURY

(Thesis format: Integrated Article)

by

Heath Andrew MacMillan

Graduate Program in Biology

A thesis submitted in partial fulfillment
of the requirements for the degree of
Doctor of Philosophy

The School of Graduate and Postdoctoral Studies
The University of Western Ontario
London, Ontario, Canada

© Heath A. MacMillan, 2013

Abstract

A mechanistic understanding of how temperature limits insect performance is needed to accurately model insect distribution and abundance. Upon crossing the temperature of their critical thermal minimum (CT_{min}), insects enter a state of paralysis (chill-coma). Chill-susceptible insects accumulate injuries (termed chilling injury) during prolonged exposure to low temperatures. My objective was to determine the mechanisms by which both chill-coma and chilling injury manifest in chill-susceptible insects. In aquatic animals, critical thermal limits are associated with a temperature-induced failure of oxygen supply relative to demand (oxygen- and capacity- limitation of thermotolerance; OCLT), which leads to reliance on anaerobic metabolism at thermal extremes. However, using open-flow respirometry and biochemical techniques, I found that fall field crickets (*Gryllus pennsylvanicus*) in chill-coma continued to exchange gases through the tracheal system and did not accumulate anaerobic byproducts, which suggests OCLT does not set the CT_{min} of insects. To characterize the patterns of ion balance disruption at low temperatures, I estimated water and ion content of the hemolymph and tissues of *G. pennsylvanicus* in chill-coma using gravimetric methods and atomic absorption spectrometry. Exposure to low temperatures caused a movement of Na^+ and water from the hemolymph to the gut in *G. pennsylvanicus*, which increased hemolymph $[K^+]$ and depolarized muscle resting potential. When removed from the cold, crickets rebalanced ions and water, and the restoration of hemolymph $[K^+]$ (and muscle equilibrium potential) was coincident with the recovery of neuromuscular function. Although crickets recover the ability to move rapidly after removal from the cold, complete recovery of ion and water homeostasis requires additional time and metabolic investment. There is both inter- and intraspecific variation in cold tolerance in flies of the genus *Drosophila*. Using ion-selective microelectrodes, I found that cold-tolerant *Drosophila* species and cold-acclimated *D. melanogaster* maintain low concentrations of $[Na^+]$ and $[K^+]$ in their hemolymph. *Drosophila* cold tolerance was also associated with low Na^+/K^+ -ATPase activity on a whole-organism level. Together, these studies allow me to construct a conceptual model of how the direct effects of temperature on ion homeostasis may drive chill-coma, chill-coma recovery and chilling injury in insects.

Keywords

Insects, chill-coma, chill-coma recovery, chilling injury, critical thermal limits, ion homeostasis.

Co-authorship statement

Chapter 2 was published as a review article in *Journal of Insect Physiology* (reprint permission in Appendix D). I was the first author of this publication, and the co-author was Brent J. Sinclair (BJS), who contributed in the conception of the ideas and helped in writing the manuscript.

Chapter 3 was published in *The Journal of Experimental Biology* (reprint permission in Appendix D). I was the first author, and the co-authors were Caroline M. Williams (CMW) James F. Staples (JFS) and BJS. CMW helped in the design and implementation of the respirometry experiment, and JFS and BJS contributed to the overall experimental design. All of the authors contributed to the preparation of the manuscript and were involved in the synthesis of many of the ideas.

Chapter 4 was published in *The Journal of Experimental Biology* (reprint permission in Appendix D). I was the first author, and BJS was the co-author. BJS contributed to the experimental design, was involved in the synthesis of many of the ideas, and helped write the manuscript.

Chapter 5 was published in *Proceedings of the National Academy of Sciences of the United States of America* (reprint permission in Appendix D). I was the first author, and the co-authors were CMW, JFS and BJS. CMW helped in the design and implementation of the respirometry experiments, and JFS and BJS contributed to the overall experimental design. All of the authors contributed to the preparation of the manuscript and were involved in the synthesis of many of the ideas.

Chapter 6 is currently being prepared for publication. I will be the first author, and co-authors will be JFS, Andrew Donini (AD), and BJS. JFS and BJS contributed to the overall experimental design and were involved in the synthesis of many of the ideas. AD contributed necessary equipment and technical expertise. BJS and JFS also provided editorial comments on the writing.

Acknowledgments

First, I am thankful for my wonderful wife, whose patience for my academic pursuits is (nearly!) endless. Christine, thank you for your support over the past 10 years. You mean everything to me. I would also like to thank my mother, Victoria MacMillan, for encouraging me to do what I love most in this life, and my father, Rick MacMillan, for introducing me to the beauty of the natural world as a child. I thank my brother, Tavis MacMillan, for his enthusiasm for science and his love of the absurd. While on the topic of family, I thank my imminently expected daughter, whose due date has been an effective motivator for thesis writing. Thank you for your timely (and entirely out of your control) existence.

It is impossible for me to imagine a PhD thesis under the supervision of better mentors than Brent Sinclair and Jim Staples. Both Brent and Jim have had an enormous influence on how I view the world, and on my role in it as a scientist. I thank Brent for his endless enthusiasm, criticism, and advice during my academic development, for recognizing my potential, and for pointing that potential toward an important topic. I thank Jim for his positivity and encouragement throughout both my undergraduate and graduate careers, and for inspiring me to pursue a career in science at a critical point in my life.

Other faculty members at Western have had an important impact on my career. I wish to thank André Lachance, for educating me on the importance of systematics in modern biology, for allowing me to pester him with questions on phylogenetics, and for officiating my marriage to Christine. I would also like to thank Mark Bernards, Jane Bowles, Robert Cumming, Sheila Macfie, Jeremy McNeil, and Amanda Moehring, for their contributions to my undergraduate education and/or useful discussions during my time in the graduate program.

I have been fortunate to be surrounded by exceptional peers in my time at Western. Katie Marshall and Caroline Williams were humbling scientists to share the majority of my time with in the Sinclair lab, and I am thankful for their help and friendship. Other students and postdoctoral researchers in the Biology Department, both past and present,

have been excellent friends and colleagues. Chris Armstrong, Evelyn Boychuk, Jason Brown, Dillon Chung, Litza Coello, Alex Cooper, Jill Crosthwaite, Lauren Des Marteaux, Laura Ferguson, Alexander and Meghan Gerson, Ruth Jakobs, Liam McGuire, Kristen Nicholson, Eddy Price, Arun Rajamohan, Golnaz Salehipour-shirazi, Justin Saindon, Stephanie Sobek-Swant, Lauren Strachan, Raymond Thomas, Hiroko Udaka, and Jian Zhang, thank you. I am known for my poor memory among my peers, and I trust that anyone I have missed in this list will forgive me. Whoever you may be, you probably mean a lot to me!

I am grateful for the Ontario Graduate Scholarship program, the Natural Sciences and Engineering Research Council of Canada (NSERC) and the Department of Biology at the University of Western Ontario for financial support over the last 6 years. I strongly believe that receipt of this financial support seeded my success as an undergraduate and graduate student by giving me the financial freedom to focus on my professional development.

Lastly, I would like to thank Brent Sinclair, Jim Staples, Chris Guglielmo, Norman Hüner, and Andrew Watson, for encouraging me to think beyond the scope of my initial research goals and embrace the unexpected. The perspective you fostered has stuck with me, and has led me down an exciting research path I could not have foreseen when I decided to start a PhD on chill-coma.

“Traditional fields of study are going to continue to grow, and in doing so, inevitably they will meet and create new disciplines. In time, all of science will come to be a continuum of description, an explanation of networks, of principles and laws. That’s why you need not just be training in one specialty, but also acquire breadth in other fields, related to and even distant from your own initial choice.” – Edward O. Wilson, Advice to Young Scientists (TEDMED 2012).

Table of contents

Abstract.....	ii
Co-authorship statement	iv
Acknowledgments.....	v
Table of contents.....	vii
List of tables.....	xiii
List of figures.....	xiv
List of videos.....	xvii
List of symbols and abbreviations	xviii
1 General introduction	1
1.1 Biotic impacts of a changing climate.....	1
1.2 What determines thermal limits to performance?.....	3
1.2.1 There is little evidence for oxygen- and capacity-limitation in terrestrial ectotherms.....	4
1.3 Insects at low temperatures.....	5
1.3.1 The insect CT_{min}	6
1.3.2 Freeze tolerance and freeze avoidance	6
1.3.3 Chill susceptibility	9
1.3.4 Variation in cold tolerance.....	11
1.3.5 Does a loss of ion homeostasis underlie insect chill-coma and chilling injury?.....	11
1.4 Insect ion and water balance.....	12
1.4.1 Ion homeostasis in excitable tissues	12
1.4.2 The insect renal system.....	14
1.5 Overview of dissertation.....	16

1.6 Literature cited.....	18
2 Physiological mechanisms of insect chill-coma	30
2.1 Introduction.....	30
2.2 Measuring chill-coma	31
2.3 Plasticity of chill-coma	33
2.4 Possible mechanisms underlying chill-coma in insects	34
2.4.1 Whole organism oxygen limitation.....	34
2.4.2 Signal transmission failure.....	35
2.4.3 Disruption of ion regulation.....	37
2.4.4 Mechanisms underlying chill-coma recovery.....	45
2.5 Conclusions.....	45
2.6 Literature cited	47
3 Metabolism and energy supply below the critical thermal minimum of a chill-susceptible insect.....	56
3.1 Introduction.....	56
3.2 Materials and methods	59
3.2.1 Respirometry.....	59
3.2.2 ATP and lactate quantification during cold exposure and recovery	60
3.2.3 Data analysis	61
3.3 Results.....	64
3.4 Discussion.....	69
3.5 Literature cited	72
4 The role of the gut in insect chilling-injury: cold-induced disruption of osmoregulation in the fall field cricket, <i>Gryllus pennsylvanicus</i>	77
4.1 Introduction.....	77
4.2 Materials and methods	80

4.2.1	Animal rearing	80
4.2.2	Determination of CT _{min} and survival of chronic cold exposure	81
4.2.3	Tissue sampling	81
4.2.4	Sample preparation and analysis.....	82
4.2.5	Data analysis	83
4.3	Results.....	84
4.3.1	CT _{min} and survival at 0 °C	84
4.3.2	Hemolymph and muscle ion concentrations.....	84
4.3.3	Tissue water content	87
4.3.4	Hemolymph and gut ion content.....	91
4.3.5	Hemolymph color	94
4.4	Discussion.....	94
4.4.1	Osmotic balance of the hemolymph and muscle	95
4.4.2	Osmotic balance of the alimentary canal	97
4.4.3	Conclusion	99
4.5	Literature cited.....	100
5	Reestablishment of ion homeostasis during chill-coma recovery in the cricket <i>Gryllus pennsylvanicus</i>	105
5.1	Introduction.....	105
5.2	Materials and methods	107
5.2.1	Animal husbandry.....	107
5.2.2	Chill-coma recovery time	107
5.2.3	Measurement of ion and water balance	107
5.2.4	Respirometry.....	110
5.2.5	Data analysis	111
5.3	Results and discussion	112

5.3.1	Chill-coma recovery.....	112
5.3.2	Loss and recovery of ion concentration, ion content and muscle equilibrium potentials	114
5.3.3	Recovery of osmotic homeostasis after cold exposure is metabolically costly	116
5.3.4	A conceptual model of chill-coma onset and recovery.....	120
5.4	Literature cited.....	122
6	Phenotypic plasticity and evolution of <i>Drosophila</i> cold tolerance are associated with modulation of Na ⁺ and K ⁺ homeostasis	126
6.1	Introduction.....	126
6.1.1	<i>Drosophila</i> as a model for variation in cold tolerance.....	127
6.1.2	Disruption of ion homeostasis underlies CT _{min} and chilling injury in insects.....	128
6.1.3	Na ⁺ /K ⁺ -ATPase plays important ionoregulatory roles in <i>Drosophila</i>	129
6.1.4	Does modulation of ion homeostasis underlie variation in insect cold tolerance?	130
6.1.5	Objectives and hypotheses.....	131
6.2	Materials and methods	133
6.2.1	Animal origins and husbandry	133
6.2.2	Measurement of CT _{min}	134
6.2.3	Hemolymph ion concentration.....	134
6.2.4	Na ⁺ /K ⁺ -ATPase activity	137
6.2.5	Data analysis	141
6.2.6	Phylogenetically-independent contrasts.....	144
6.3	Results.....	147
6.3.1	Critical thermal minima	147
6.3.2	Hemolymph ion concentration.....	147

6.3.3	Na ⁺ /K ⁺ -ATPase activity	150
6.3.4	Na ⁺ /K ⁺ -ATPase transcript and protein abundance.....	153
6.4	Discussion.....	156
6.4.1	Cold acclimation mitigates the effects of low temperature on hemolymph [K ⁺]	156
6.4.2	Improvements in cold tolerance through modulation of resting hemolymph [Na ⁺] and [K ⁺].....	157
6.4.3	Do cold tolerant insects decouple Na ⁺ and water balance?	158
6.4.4	<i>Drosophila</i> cold tolerance is associated with low Na ⁺ /K ⁺ -ATPase activity	159
6.4.5	Conclusion	162
6.5	Literature cited	162
7	General Discussion	173
7.1	Thesis summary	173
7.2	A conceptual model of chill-susceptibility	174
7.3	Limitations and remaining gaps in the model.....	177
7.3.1	Taxonomic and contextual expansion of the conceptual model.....	178
7.3.2	Does ion balance disruption cause chill-coma and chilling injury?	179
7.3.3	Elucidating the routes of ion and water migration in the cold.....	181
7.4	What are the mechanisms of cold tolerance plasticity and evolution?	181
7.4.1	Variation in ion pump thermal sensitivity and the role of the membrane environment	184
7.4.2	Modulation of transcellular and paracellular permeability.....	185
7.4.3	Modification of cellular and epithelial ion gradients and diet effects on cold tolerance	188
7.4.4	Inhibition of apoptosis – a final stand against chilling injury?.....	190
7.5	Concluding remarks	191

7.6 Literature cited.....	192
Appendix A: Chapter 4 supplementary material	199
Appendix B: Chapter 5 supplementary material.....	202
Appendix C: Chapter 6 supplementary material.....	208
Supplementary methods.....	208
Hemolymph collection.....	208
Measurement of Na ⁺ /K ⁺ -ATPase activity.....	208
Appendix D: Reprint permissions.....	218
Reprint permission for chapter 2.....	218
Reprint permission for chapters 3 and 4	222
Reprint permission for chapter 5.....	223
Curriculum vitae	224

List of tables

Table 7.1. Physiological mechanisms hypothesized to underlie variation in the cold tolerance of chill susceptible insects.....	183
Table A.1. Results of false discovery rate corrected t-tests and general linear models of hemolymph and muscle ion concentrations and calculated muscle equilibrium potentials of <i>Gryllus pennsylvanicus</i> exposed to 0 °C.	199
Table A.2. Results of false discovery rate corrected t-tests and general linear models of hemolymph and tissue water content of <i>Gryllus pennsylvanicus</i> exposed to 0 °C.....	200
Table A.3. Results of false discovery rate corrected t-tests and general linear models of hemolymph, foregut, midgut and hindgut ion content of <i>Gryllus pennsylvanicus</i> exposed to 0 °C.	201
Table B.1. Results of linear and non-linear regression of cricket chill-coma recovery time and cold exposure duration.	202
Table B.2. Results of t-tests of the effects of 24 h of exposure to 0 °C on hemolymph, muscle and gut ion and water content.....	203
Table B.3. Results of linear (L) and non-linear (NL) models (M) of <i>G. pennsylvanicus</i> hemolymph, muscle and gut ion and water content during chill-coma recovery following 24 h at 0 °C.	204
Table C.1. Details of <i>Drosophila</i> species stock origins and critical thermal minima estimates.....	214
Table C.2. Summary of physiological variables measured in <i>Drosophila</i> species (mean ± sem).....	215

List of figures

Figure 1.1. Terminology of cold tolerance measures typically quantified in a chill-susceptible insect in the laboratory.....	7
Figure 1.2. Overview of physiological mechanisms of ion and water homeostasis of the hemolymph (white) gut lumen (light grey) and cell cytoplasm (dark grey) of a typical phytophagous insect.....	13
Figure 2.1. Schematics of the relationship between the capacity to actively transport ions across membranes (which has a Q_{10} between 2 and 3) and the rate of ion diffusion through available pathways (relatively unaffected by temperature; Zachariassen et al., 2004) to illustrate possible mechanisms underlying chill-coma in insects.....	39
Figure 2.2: The interactive effects of cold exposure temperature and duration on chill-coma recovery time of female <i>Drosophila melanogaster</i> reared at 25 °C.	44
Figure 2.3. Schematic of physiological mechanisms of neuromuscular transmission failure thought to underlie insect chill-coma at low temperatures.....	46
Figure 3.1. An example of respirometry and activity data from one adult female <i>Gryllus pennsylvanicus</i> during a temperature ramp.....	63
Figure 3.2. CO ₂ release and slope of activity absolute difference sum (ADS) of female <i>Gryllus pennsylvanicus</i> during a linear temperature ramp from 20°C to 0°C at 0.25°C min ⁻¹	65
Figure 3.3. Concentrations of ATP (black), lactate (white) and alanine (gray) in the hind femur of female adult <i>Gryllus pennsylvanicus</i> (A) during exposure to 0 °C and (B) during recovery at 20 °C from 24 h in chill-coma at 0°C.	66
Figure 3.4. Concentrations of ATP, lactate and alanine in the hind femur of female adult <i>Gryllus pennsylvanicus</i> under normoxic conditions (white bars) and following 1h of anoxia at 20 °C (gray bars).	68

Figure 4.1. Survival of <i>G. pennsylvanicus</i> 6 h (A) and 24 h (B) following removal from exposure to 0 °C for up to 120 h.....	85
Figure 4.2. Concentration (mean ± sem) of Na ⁺ (A), K ⁺ (B), Mg ²⁺ (C) and Ca ²⁺ (D) in hemolymph (filled) and femur muscle tissue (open) of <i>G. pennsylvanicus</i> during exposure to 0 °C for up to 120 h.	86
Figure 4.3. Calculated equilibrium potentials (mean ± sem) of Na ⁺ (filled circles), K ⁺ (open circles), Mg ²⁺ (filled triangles) and Ca ²⁺ (open triangles) of muscle cell membranes of <i>G. pennsylvanicus</i> during prolonged exposure to 0 °C.	88
Figure 4.4. Mean ± sem muscle water content (A; expressed as μL per mg of muscle dry mass) and hemolymph volume (filled circles) and total gut water content (open circles) (B) of <i>G. pennsylvanicus</i> during exposure to 0 °C for up to 120 h.	89
Figure 4.5. Mean (± sem) foregut (A), midgut (B), and hindgut (C) water content (expressed as μL per mg tissue dry mass) of <i>G. pennsylvanicus</i> exposed to 0 °C for up to 120 h.....	90
Figure 4.6. Mean (± sem) total Na ⁺ (A), K ⁺ (B), Mg ²⁺ (C), and Ca ²⁺ (D) content of the hemolymph of <i>G. pennsylvanicus</i> during exposure to 0 °C for up to 120 h.....	92
Figure 4.7. Mean (± sem) Na ⁺ (A-C), K ⁺ (D-F), Mg ²⁺ (G-I), and Ca ²⁺ (J-L) of the foregut (left) midgut (centre) and hindgut (right) of <i>G. pennsylvanicus</i> during exposure to 0 °C for 120 h.....	93
Figure 5.1. The relationship between gravimetric estimates of hemolymph volume and volume quantified using the inulin dilution method in <i>G. pennsylvanicus</i>	108
Figure 5.2. Time taken for female <i>G. pennsylvanicus</i> to recover movement after exposure to 0 °C.	113

Figure 5.3. Hemolymph concentration (A), muscle equilibrium potential (B), total hemolymph ion content (C) of Na ⁺ (black) and K ⁺ (grey), and (D) hemolymph volume (filled squares) and gut water content (open squares) of female <i>G. pennsylvanicus</i> during recovery at 22 °C following 24 h at 0 °C.....	115
Figure 5.4. An example measurement of metabolic rate (rate of CO ₂ emission, black line, baseline-corrected values shown) and activity (grey line, arbitrary units) of a <i>G. pennsylvanicus</i> female (A) prior to and (B) immediately upon removal from a 20 h exposure to 0 °C.....	118
Figure 5.5. The relationship between the duration of metabolic overshoot during chill-coma recovery and exposure to 0 °C (solid circles).	119
Figure 5.5. A conceptual model of the effects of temperature (grey line) on muscle resting potential (black line) of a chill-susceptible insect during a typical experimental cold exposure.	121
Figure 6.1. Flow-chart of experimental design.....	135
Figure 6.2. Example of a logistic model (solid grey line) fitted to Na ⁺ /K ⁺ -ATPase activity of warm-acclimated <i>Drosophila melanogaster</i> (solid black line).	143
Figure 6.3. Phylogeny of the genus <i>Drosophila</i> and among-species variation in the CT _{min}	146
Figure 6.4. Hemolymph Na ⁺ (A) and K ⁺ (B) concentrations of cold-acclimated (grey bars) and warm-acclimated (open bars) male <i>Drosophila melanogaster</i> at their acclimation temperature (Control) and following 6 h at 0 °C.	148
Figure 6.5. Hemolymph concentrations of Na ⁺ (A) and K ⁺ (B) of species of the genus <i>Drosophila</i> in relation to the CT _{min}	149
Figure 6.6. Na ⁺ /K ⁺ -ATPase activity (A), and inflection point (<i>IP</i>) and thermal sensitivity (<i>T_s</i> ; B) of <i>Drosophila melanogaster</i>	151

Figure 6.7. Mean (\pm sem) Na ⁺ /K ⁺ -ATPase activity at 21.5 °C (A) inflection point (B) and thermal sensitivity (C) of species of the genus <i>Drosophila</i> in relation to the CT _{min}	152
Figure 6.8. Na ⁺ /K ⁺ -ATPase protein (A, B) and mRNA (C) abundance in warm- and cold-acclimated <i>Drosophila melanogaster</i>	154
Figure 7.1. A physiological model integrating ionic mechanisms of chill-coma, chilling injury and chill-coma recovery in chill-susceptible insects.	175
Figure B.1. Muscle concentration of Na ⁺ (black) and K ⁺ (grey) during chill-coma recovery at 22 °C following 24 h at 0 °C. B).....	205
Figure B.2. Residual water (A-D), Na ⁺ (E-H), and K ⁺ (I-L) content of each of the three gut segments and total gut of crickets during chill-coma recovery at 22 °C following 24 h at 0 °C.	206
Figure C.1. Schematic of the apparatus used to collect hemolymph from <i>Drosophila</i> without anesthesia.	210
Figure C.2. Na ⁺ /K ⁺ -ATPase activity recorded using a temperature ramp and comparison to activity measured at static temperatures.	212
Figure C.3. Histograms of critical thermal minima of female (black bars) and male (grey bars) flies of the genus <i>Drosophila</i>	216
Figure C.4. Phylogenetically-independent contrasts (PICs) of the critical thermal minimum (CT _{min}) regressed against hemolymph ion concentrations (A,B) and Na ⁺ /K ⁺ -ATPase parameters (C-E; See Section 6.2.6).	217

List of videos

Video B.1. Example video recording of a cricket (8 × speed) inside the respirometry chamber with accompanying CO ₂ trace (top left panel) during chill-coma recovery at 22°C following 16 h at 0 °C.....	207
---	-----

List of symbols and abbreviations

Ψ	Membrane potential
aADS	Absolute difference sum of activity
ADS	Absolute difference sum
ATP	Adenosine triphosphate
ATPase	Adenosine triphosphatase
CCR	Chill-coma recovery time
T_{cc}	Chronic exposure temperature that causes chill-coma
CT_{max}	Critical thermal maximum
CT_{min}	Critical thermal minimum
E_X	equilibrium potential of X
IP	Inflection point of temperature-activity curve
LD_{50}	Lethal dose for 50 % of individuals
OCLT	Oxygen- and capacity-limitation of thermotolerance
NADH	Nicotinamide adenine dinucleotide (reduced form)
Q_{10}	Temperature coefficient
T_s	Thermal sensitivity
RCH	rapid cold hardening
vADS	absolute difference sum of rate of CO_2 release
$\dot{V}CO_2$	Rate of CO_2 release

Chapter 1

1 General introduction

1.1 Biotic impacts of a changing climate

Global surface temperatures have risen by 0.5 °C in the last 20 years, and are predicted to rise by at least a further 1.8-4.0 °C by the end of this century as a result of anthropogenic activities (IPCC, 2007a). Along with an increase in mean temperature, the world is already experiencing rapid declines in snow and ice cover, rising ocean levels, increased precipitation and elevated risk of extreme weather events (IPCC, 2007b). The rates of environmental change observed and expected for our planet are unprecedented in the last 11,300 years, and are recognized as a major threat to biodiversity and ecosystem health (Fischlin et al., 2007; Marcott et al., 2013). In particular, climate change increases risks of species extinction and invasive species, and can alter the abundance of species important to agriculture and human health. The potential effects of climate change on biota demand understanding of how changes in the abiotic environment influence fitness, both directly (e.g. physiological limits to tolerance) and indirectly through alterations in biotic interactions (e.g. timing of seasonal events or food availability; Cahill, 2013; Chown and Gaston, 2008; Thackeray et al., 2010).

Temperature plays a central role in the effort to understand species' range limits. Environmental temperature is of particular importance to ectothermic animals, whose body temperature is equal to that of the external environment. Ectotherms live within a thermal window, a range of body temperatures over which cellular and systemic processes operate, which is bounded by a critical thermal maximum (CT_{max}) and critical thermal minimum (CT_{min}). The effects of changing global climate on ectotherms will depend on the proximity of mean and extreme habitat temperatures to these critical thermal limits, and while it is intuitive to expect that high temperatures will be the main driving force of climate change effects (Deutsch et al., 2008; Pörtner et al., 2006), this is

not necessarily the case. Poleward range limits are in part determined by the frequency and severity of low temperatures over winter, so increased winter survival may facilitate poleward expansion of species ranges (Crozier, 2003). Winter warming in temperate ecosystems may enhance fitness by lengthening the seasons of growth and reproduction, or reduce fitness through phenological shifts (Jeong et al., 2011). For example, extended periods of pre-winter dormancy in the spruce budworm, *Choristoneura fumiferana* (Lepidoptera: Tortricinae), and increases in post-winter thermal variability in *Erynnis propertius* (Lepidoptera: Hesperiiidae), both reduce fitness by elevating metabolic rate and depleting energy stores required for summer development and reproduction (Han and Bauce, 1998; Williams et al., 2012). Animal distributions have already shifted in response to warming (Chen et al., 2011). In marine systems, distributions of several fish species in the North Sea have shifted northward with increased temperatures (Perry et al., 2005) while in terrestrial systems, shifts in range limits have been well documented in insects and are often directly attributed to warmer winters (Battisti et al., 2005; Chen et al., 2011; Crozier, 2003; Jepsen et al., 2008).

It is generally agreed that accurate models of animal distribution and abundance require integration of information at multiple levels of biological organization, including morphology, behaviour, physiology and genetics (Bozinovic et al., 2011; Gaston et al., 2009; Helmuth et al., 2005). The physiological limits to tolerance of abiotic stressors strongly influence species distribution and abundance (Kearney and Porter, 2009; Pörtner, 2002), and this realization has rekindled interest in the mechanisms underlying abiotic limits in animals. Macrophysiology, the study of physiological trait variation across geographic and temporal scales (Chown and Gaston, 2008; Chown et al., 2004), attempts to address broad ecological patterns through physiological understanding. Although powerful, such an approach requires integrative knowledge of the physiological mechanisms that underlie whole-organism tolerance limits, the broad phylogenetic patterns of those traits, and their capacity to evolve (Feder, 2007; Pörtner et al., 2006). Only when comparative physiology can provide unifying principles of how abiotic limits shape fitness will mechanistically informed predictions of animal distribution and abundance be possible (Pörtner, 2010). A primary goal of this dissertation is to contribute to the current understanding of how low temperatures limit insect performance.

1.2 What determines thermal limits to performance?

Our understanding of how temperature impacts organismal physiology, thereby setting critical thermal limits, is incomplete. In particular, the mechanisms by which high and low temperatures limit the performance of terrestrial animals are largely unknown. In aquatic systems, however, the CT_{max} and CT_{min} of animals that breathe water appear to be physiologically linked through the effects of temperature on oxygen supply and demand.

The hypothesis of oxygen- and capacity-limitation of thermal tolerance (OCLT) has emerged as a broadly applicable framework of the physiological mechanisms underlying thermal limits to performance in aquatic ectotherms (Pörtner and Farrell, 2008; Pörtner and Knust, 2007). The OCLT hypothesis proposes that limits to animal performance arise from declining aerobic scope (the difference between maximal and standard metabolic rate) at temperature extremes (Pörtner and Knust, 2007). At both high and low temperatures, the circulatory and ventilatory systems become incapable of delivering sufficient oxygen to tissues to maintain aerobic metabolism. Thus, the CT_{min} and the CT_{max} represent boundaries of a window of aerobic metabolism, and beyond these boundaries hypoxemia in critical tissues limits aerobic ATP production, leading to failure of energy-demanding processes like muscle contraction (Pörtner and Farrell, 2008). The energy made available through anaerobic metabolism is prioritized to cellular mechanisms of defense, and over time anaerobic byproducts accumulate, causing injury and death. This physiological link between both thermal limits explains why the CT_{min} and CT_{max} of marine ectotherms shift in unison across latitudinal clines (Sunday et al., 2011).

The principles of OCLT have been tested and supported at both high and low temperatures in a broad range of aquatic ectotherms, including fish (Pörtner and Knust, 2007), cephalopods (Melzner et al., 2007), bivalves (Peck et al., 2002), marine annelids (Zielinski and Pörtner, 1996), crustaceans (Frederich and Pörtner, 2000), and even zooplankton (Seidl et al., 2005). Oxygen limitation theory also serves to explain patterns in biogeography. The aerobic windows of salmon populations that complete a single summer migration up the Fraser River and its tributaries are locally adapted to historical temperatures of their migration routes (Farrell et al., 2008). Salmon populations that face

more physically or thermally challenging migrations have apparently adapted to these challenges through increased aerobic scope, facilitated by larger hearts and improved coronary blood supply (Eliason et al., 2011). Variation in thermal tolerance of aquatic ectotherms has also been associated with alteration of the aerobic window. Temperate species alter their thermal tolerance by increasing the mitochondrial density of their skeletal muscles (e.g. Tyler and Sidell, 1984; Johnston et al., 1998), increasing cardiac performance at extreme temperatures (e.g. Gamperl and Farrell, 2004), or by modifying the oxygen transport properties of their blood (e.g. Melzner et al., 2007).

Thus, in aquatic animals, there is strong evidence that the thermal window of performance is determined by a thermal window of aerobic metabolism, and that the aerobic window ultimately impacts biogeography. The success of the OCLT hypothesis and its broad applicability to marine animals has led to application of OCLT concepts to predictive models of animal distribution. In the case of Fraser River salmon, a recent study used aerobic scope to predict stock-specific declines in abundance between 9 and 16 % by the end of this century (Martins et al., 2011).

1.2.1 There is little evidence for oxygen- and capacity-limitation in terrestrial ectotherms

The OCLT hypothesis has not been well-studied in terrestrial ectotherms, but current evidence suggests that aerobic scope is unlikely to set the CT_{min} and CT_{max} of most animals that breathe air. Unlike aquatic animals, the upper and lower thermal limits of terrestrial ectotherms do not appear to be linked; the CT_{max} of terrestrial ectotherms shows little geographical variation, but lower limits to performance decline with latitude, such that temperate species simply have wider thermal windows (Addo-Bediako et al., 2000; Sunday et al., 2011). Despite temperature effects on locomotor performance, aerobic scope and oxygen content of the arterial blood are unaffected by high temperature exposure in cane toads (*Rhinella marina*, Anura: Bufonidae), even at temperatures immediately below the lethal limit of this species (Overgaard et al., 2012; Seebacher and Franklin, 2011). Amphibian muscles do become more dependent on anaerobic energy production during cold exposure, but this trend has been associated with higher metabolic

costs of muscle function at low temperatures, rather than temperature effects on oxygen supply (Petersen and Gleeson, 2009; Seebacher and Franklin, 2011).

Unlike aquatic animals and terrestrial vertebrates, insects do not deliver oxygen to tissues via a circulatory system. Instead, gaseous air is delivered to tissues through the tracheal system, blind-ended tubes that are continuous with the external environment. The tracheal system delivers oxygen efficiently even at ambient oxygen concentrations below 10 % (Harrison et al., 2001), meaning oxygen supply to insect tissues is unlikely to be limited in normoxia. A hypothesis that has been derived from OCLT is that experimental modulation of oxygen availability through hypoxia or hyperoxia should alter the CT_{\min} and CT_{\max} (Klok et al., 2004; Pörtner, 2001). By manipulating ambient oxygen concentration, however, Klok et al. (2004) found that oxygen availability only altered the CT_{\max} of tenebrionid beetles (*Gonocephalum simplex*, Coleoptera: Tenebrionidae) under extreme hypoxia (2.5 % O_2). Similarly, oxygen availability has no effect on the CT_{\min} of a related tenebrionid (*Tenebrio molitor*, Coleoptera: Tenebrionidae; Stevens et al., 2010). By contrast, the CT_{\max} of a terrestrial isopod (*Armadillidium vulgare*, Isopoda: Armadillidiidea), which does exchange gases through a circulatory system, is reduced in hypoxia (Klok et al., 2004). Thus, the OCLT hypothesis may hold for terrestrial crustaceans, but does not appear to hold for terrestrial vertebrates or tracheated insects. No study to date, however, has directly tested whether chronic low or high temperature exposure leads to failure of aerobic metabolism and accumulation of anaerobic byproducts in an insect, so it remains uncertain if OCLT sets insect thermal limits in normoxia.

1.3 Insects at low temperatures

The low temperature biology of insects has been summarized in many comprehensive reviews (e.g. Bale, 2002; Doucet et al., 2009; Lee, 1991; Lee and Denlinger, 2010; Michaud and Denlinger, 2004; Sinclair, 1999; Sinclair et al., 2003; Storey and Storey, 2012). To avoid low temperatures, some terrestrial insects thermoregulate in groups (e.g. honeybees), migrate to warmer climates (e.g. butterflies), or burrow below the frost layer

in soil or under snow, where buffered microclimate temperatures rarely decline below 0 °C (Seeley and Visscher, 1985; Storey and Storey, 2012; Zipkin et al., 2012). Other species, however, regularly experience sub-zero winter temperatures, and some have evolved physiological means of low temperature survival that are traditionally split into two principal strategies: freeze tolerance and freeze avoidance (Salt, 1961).

1.3.1 The insect CT_{min}

The insect CT_{min} is a temperature that marks the onset of chill-coma, a state of complete paralysis (Figure 1.1; Hazell and Bale, 2011; Mellanby, 1939). Provided the duration of cold exposure is short, chill-coma is reversible, as insects removed from the cold to warmer temperatures will recover the ability to move. Recovery from chill-coma has been quantified as the ambient temperature required for an insect to regain the ability to move (Fordyce and Shapiro, 2003), but is more commonly measured as the time required for the insect to recover the ability to stand following removal from the cold to room temperature, termed chill-coma recovery time (CCR; Figure 1.1; David et al., 1998). Both the CT_{min} and CCR are commonly-used measures of insect cold tolerance (e.g. Ayrinhac et al., 2004; Folk et al., 2007; Gaston and Chown, 1999; Gibert and Huey, 2001; Gibert et al., 2001; Ransberry et al., 2011). In this dissertation, recovery from chill-coma is always measured as a time to recovery at a static temperature, but some distinctions are made between the time required for the ability to stand (CCR), the recovery of muscle function, and recovery of ventilation (Chapter 3). A detailed introduction to the physiology thought to underlie chill-coma and chill-coma recovery is presented in Chapter 2.

1.3.2 Freeze tolerance and freeze avoidance

For most insects, freezing causes extensive damage and death through physical damage to membranes and macromolecules and alterations in osmotic forces as water is incorporated into ice (Storey and Storey, 1988). Freeze tolerant insect species, however, survive freezing of a large proportion of their body fluids (Storey and Storey, 2012).

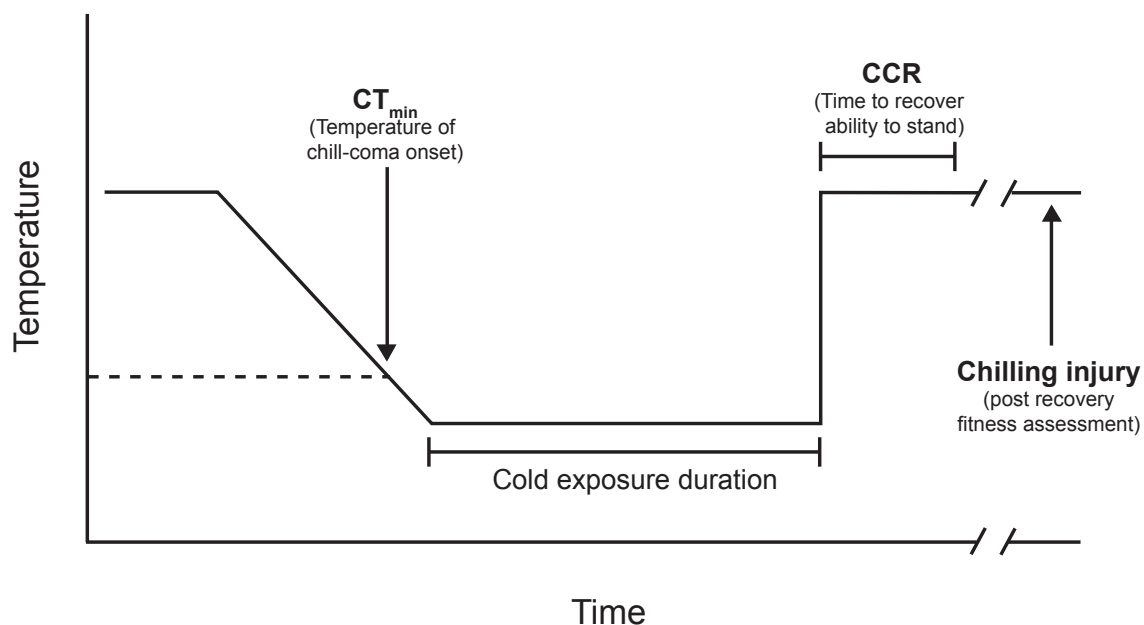

Figure 1.1. Terminology of cold tolerance measures typically quantified in a chill-susceptible insect in the laboratory. A typical experimental cold exposure is shown, where temperature is decreased at a constant rate and then held at a low temperature. The CT_{min} is measured as the temperature at which a loss of coordination occurs (typically an inability to stand or cling to a surface). At temperatures below the CT_{min} , insects enter chill-coma, which is a state of complete paralysis. Recovery is typically accomplished by removing the insect to room temperature. Chill-coma recovery time (CCR) is the time required to recover the ability to move or stand, and varies according to the duration and temperature of cold exposure. Incidence of chilling injury following a cold stress may be quantified by mortality or impairment of functions related to fitness, typically measured 24 h following removal from the cold stress.

In freeze tolerant insects, ice formation is initiated in the extracellular space by ice nucleating agents or ice nucleating proteins, and initiation of freezing at relatively mild sub-zero temperatures may allow for slow and controlled freezing that minimizes physical damage (Layne et al., 1988; Zachariassen and Kristiansen, 2000; but see Sinclair et al., 2009). In freeze tolerant insects, the intracellular space is kept in a liquid state and cell membranes are protected by the accumulation of low molecular weight cryoprotectants such as glucose, glycerol, and trehalose (Storey, 1997). Ice formation in the extracellular space increases local osmotic pressure, which provides the driving force for water to cross cell membranes through aquaporins. The redistribution of water during extracellular freezing reduces cell volume and the likelihood of intracellular freezing (Lee and Denlinger, 2010). Frozen insects survive substantial redistribution of water from intracellular to extracellular spaces during freezing, but lose very little total body water to their environment because extracellular water is largely bound as ice (Irwin and Lee, 2002; Lundheim and Zachariassen, 1993).

Freeze avoiding insects depress the supercooling point (SCP; the temperature at which a fluid spontaneously freezes) of their body fluids and remain unfrozen at low sub-zero temperatures by eliminating potential ice nucleators from the body, producing antifreeze proteins that bind to ice crystals and inhibit their growth, and again by accumulating cryoprotectants (Lee and Denlinger, 2010). In freeze avoiding insects, high concentrations of cryoprotectants facilitate colligative supercooling point suppression. For example, overwintering prepupae of the emerald ash borer (*Agrilus planipennis*, Coleoptera: Buprestidae) accumulate nearly 4M glycerol in their hemolymph, produce antifreeze agents, and lose substantial body water, all facilitating depression of their SCP to -30 °C (Crosthwaite et al., 2011).

A third strategy of cold tolerance, cryoprotective dehydration, can be viewed as a specialized form of freeze avoidance that is common among soil dwelling collembolans, and has been documented in an Antarctic chironomid (*Belgica antarctica*, Diptera: Chironomidae; Elnitsky et al., 2008; Sørensen and Holmstrup, 2011). For animals that utilize cryoprotective dehydration, differences in water vapour pressure between unfrozen body fluids and ice surrounding the animal in the soil cause a loss of freezable body

water. Animals that utilize cryoprotective dehydration over the winter remain in vapour pressure equilibrium with their environment (Sørensen and Holmstrup, 2011).

1.3.3 Chill susceptibility

The majority of insects globally are neither freeze tolerant nor freeze avoidant, but are chill-susceptible (Bale, 1996). At temperatures below the CT_{min} , chill-susceptible insects accumulate injuries and may die from processes that are unrelated to freezing of their body fluids (Bale, 1996; Baust and Rojas, 1985). Such insects are the focus of this dissertation.

Injuries sustained from exposure to low temperatures but unrelated to freezing are termed chilling injury. Chilling injury on a whole-organism level has been quantified in a several ways, the simplest of which is the incidence of mortality following a non-freezing cold exposure (Turnock, 1993; Turnock et al., 1983). Other common measures of chilling injury are functions related to fitness, such as the ability to move in a coordinated fashion, resume development, mate, or lay eggs following recovery from a cold exposure (typically measured 24 h after the stress; Figure 1.1; Košťál and Tollarová-Borovanská, 2009; Košťál et al., 2006; Marshall and Sinclair, 2010; Rinehart et al., 2000; Rojas and Leopold, 1996). The accumulation of chilling injury in chill-susceptible insects is both time- and temperature-dependent; sustained exposure to low temperatures causes more damage and greater mortality than brief exposure to relatively mild temperatures (Nedvěd et al., 1998; Turnock et al., 1983).

Damage accrued during cold exposure is often categorized according to the cold exposure experienced (Michaud and Denlinger, 2004; Sinclair and Roberts, 2005). The terms ‘cold shock’ or ‘direct chilling injury’ are used to describe injuries sustained during acute exposure to temperatures below 0 °C but above the SCP, such as exposure to -5 °C for 2 h (e.g. Czajka and Lee, 1990). By contrast, the terms ‘indirect chilling injury’ or simply ‘chilling injury’ are used to describe the effects of chronic exposure to temperatures at or near 0 °C, such as exposure to 0 °C for several days (e.g. Dollo et al., 2010; Košťál et al., 2006).

Impairments of whole-organism fitness via cold shock and indirect chilling injury are associated with damage sustained in sensitive tissues, particularly the neuromuscular system and gut. Yocum et al. (1994) noted that flesh flies (*Sarcophaga crassipalpis*, Diptera: Sarcophagidae) that failed to emerge from their puparium following chronic cold exposure lacked the coordination to do so, and ascribed chilling injury to nervous system damage. Damage to the neuromuscular system can be further inferred from observation of insect gait following low temperature exposure; insects that have sustained chilling injury walk in an uncoordinated manner (Košťál et al., 2006). Cold shock treatments induce high levels of cellular apoptosis in the flight muscles of *Drosophila melanogaster* (Yi et al., 2007), as well as the muscle, fat body and gut tissues of flesh flies (Yi and Lee, 2004; Yi and Lee, 2011), so chilling injury may result from cold-induced cellular apoptosis.

The physiological mechanisms of cold shock and indirect chilling injury appear to differ. Cold shock has been associated primarily with cell membrane damage as a result of membrane phase-transitions (Drobnis et al., 1993; Lee et al., 2006; Vigh et al., 1998), and disruption of the cytoskeleton (Cottam et al., 2006), which result in either apoptotic or necrotic cell death (Garcia et al., 2002; Yi et al., 2007). The physiology underlying indirect chilling injury accrued during chronic cold exposure is not as well-understood, but has been associated with metabolic disturbance (resulting in imbalances in ATP supply and demand), oxidative stress, and (of particular importance to this dissertation) progressive loss of ion and water homeostasis (Dollo et al., 2010; Košťál et al., 2004; Košťál et al., 2006; Lalouette et al., 2007; Rojas and Leopold, 1996). Overlap in the occurrence of these mechanisms of injury between cold shock and indirect chilling injury have not been well-studied, so the physiological boundaries between the two forms of injury may be less distinct than is currently apparent. Regardless, in this dissertation insects were exposed to a temperature of 0°C for a time period of several hours to days, so any injury identified following recovery from cold stress herein can be interpreted as indirect chilling injury.

1.3.4 Variation in cold tolerance

The cold tolerance of chill-susceptible insects can vary widely among species and populations, and many species have substantial capacity for cold tolerance plasticity. Cold tolerance variation has been particularly well characterized in the predominantly chill-susceptible genus *Drosophila* (Diptera: Drosophilidae). Temperate *Drosophila* species and populations are generally more cold tolerant (i.e. have lower CT_{min} and faster CCR) than those from the tropics, and much of this variation persists under common laboratory rearing conditions (Ayrinhac et al., 2004; David et al., 2003; Gibert and Huey, 2001; Kellermann et al., 2012). Cold tolerance of chill-susceptible insects is also highly phenotypically plastic. For example, the CT_{min} and CCR of *Drosophila melanogaster* can be altered in response to long-term exposure to variable temperatures in the field, or to laboratory rearing and acclimation temperatures (Nyamukondiwa et al., 2011; Overgaard and Sørensen, 2008; Ransberry et al., 2011). Tolerance of chill-susceptible insects to a severe cold exposure can also be altered by brief (c. 30 min) prior exposure to a relatively mild low temperature, a response termed rapid cold hardening (RCH; Czajka and Lee, 1990; Lee et al., 1987). Thus, chill-susceptible insects are not simply passive victims of their thermal environment, but can often successfully avoid chill-coma and damage from cold exposure through cold tolerance plasticity. The physiological mechanisms by which cold tolerance can be improved in chill-susceptible insects are largely unknown, in part because the mechanisms that drive the CT_{min} , CCR, RCH, and chilling injury are poorly understood.

1.3.5 Does a loss of ion homeostasis underlie insect chill-coma and chilling injury?

Both the onset of chill-coma and indirect chilling injury are associated with a loss of ion homeostasis in insects. The cessation of movement that defines chill-coma is coincident with a failure in the function of nerves and muscles that appears to be driven by a loss of ion homeostasis in these excitable tissues (Esch, 1988; Goller and Esch, 1990; Hosler et al., 2000; Rodgers et al., 2010; Staszak and Mutchmor, 1973). For example, tropical cockroaches (*Nauphoeta cinerea*; Blattodea: Blaberidae) acclimated to 30 °C progressively lose muscle resting potentials and die after exposure to 5 °C for several

days (Košťál et al., 2006). Similarly, adult firebugs (*Pyrrhocoris apterus*, Hemiptera: Pyrrhocoridae) progressively lose ion balance between their hemolymph and tissues and die following long-term exposure to -5 °C (Košťál et al., 2004).

Plasticity of cold tolerance appears to be associated with modulation of ion balance physiology. Cold-acclimated firebugs better maintain ion balance between their hemolymph and tissues, and show markedly better survival following cold exposure than warm-acclimated individuals (Košťál et al., 2004). Similarly, cold-acclimated cockroaches maintain muscle resting potentials at 5 °C and remain active (Košťál et al., 2006). Thus, cold exposure appears to disrupt ion homeostasis in critical tissues that drives both chill-coma and chilling injury. In turn, variation in insect cold tolerance may be mediated by variation in ionoregulatory physiology.

1.4 Insect ion and water balance

If exposure to low temperatures causes a loss of ion homeostasis, cold exposure is likely to impair functions of excitable tissues that are dependent on ion distribution, such as the nerves and muscles, as well as the renal epithelia that maintain whole-organism ionic and osmotic balance.

1.4.1 Ion homeostasis in excitable tissues

Neuromuscular function depends on the unequal distribution of ions across neuron and muscle cell membranes. Although their nerves are bathed in hemolymph, insect neurons are highly sensitive to their ionic environment, and are protected from the hemolymph composition (particularly its relatively high K⁺ concentration that would render them unexcitable) by the blood-brain barrier (Figure 1.2). This barrier is composed of glial cells that ensheath neuron bodies, axons, and dendrites, and are tightly joined by pleated septate junctions. The perineurial glia, the outermost layer of cells, produce the neural lamina (a thick extracellular matrix; Stork et al., 2008). The arrangement of the blood-brain barrier limits paracellular movement of water and ions between the hemolymph and the immediate extracellular environment of neurons (Leiserson and Keshishian, 2011).

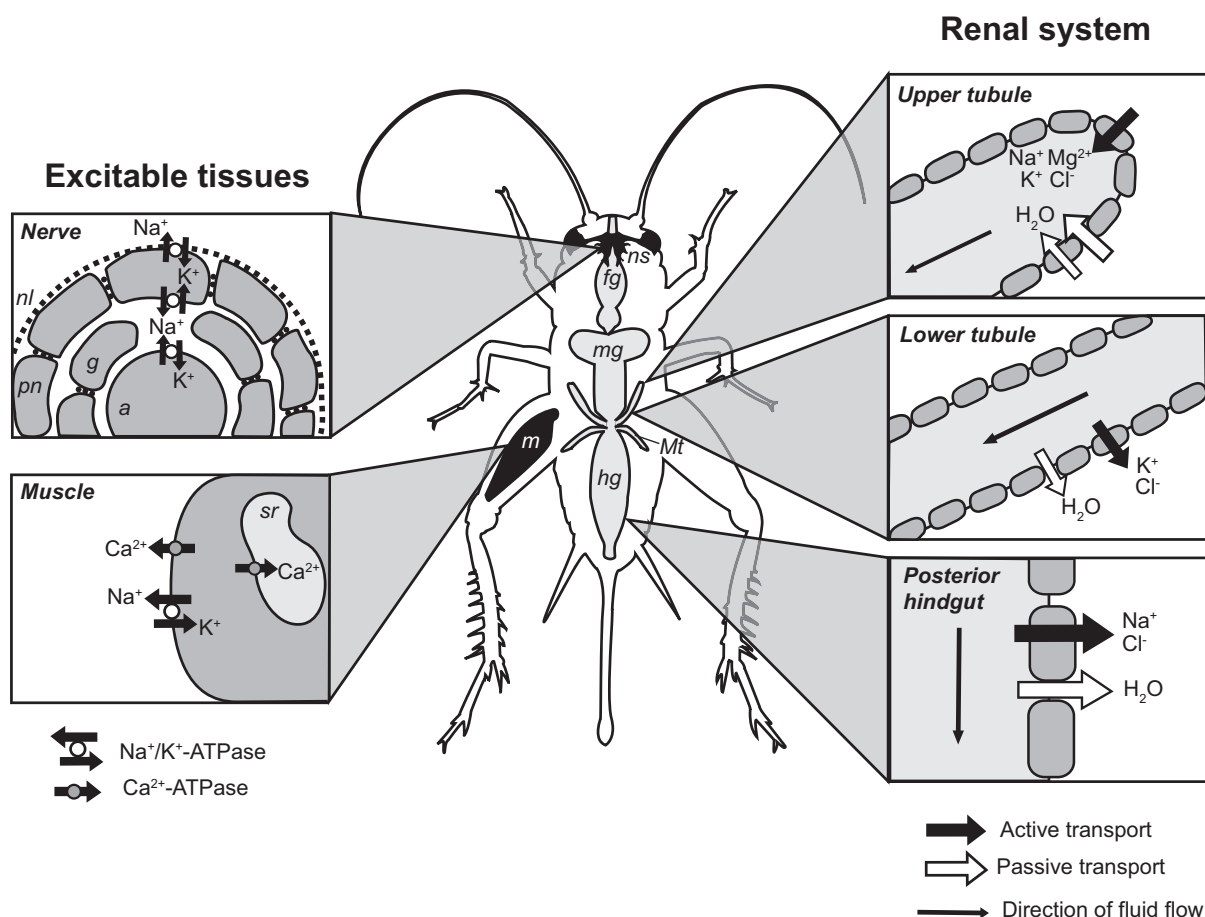

Figure 1.2. Overview of physiological mechanisms of ion and water homeostasis of the hemolymph (white) gut lumen (light grey) and cell cytoplasm (dark grey) of a typical phytophagous insect. Intracellular homeostasis of the nervous system (*ns*) and muscles (*m*) are primarily maintained by active pumping of the cations Na^+ , K^+ and Ca^{2+} . Nerve axons (*a*) are protected from changes in hemolymph composition by the blood-brain barrier, composed of glial cells (*g*) with tight septate junctions (black circles) that restrict paracellular ion and water leak. The outermost layer of the blood-brain barrier is the perineurial glia (*pn*), which secrete the neural lamella (*nl*), a thick extracellular matrix. Muscle cells are bathed directly in hemolymph, and ion balance is maintained across the muscle cell membrane. High levels of primary and secondary active ion transport drive transport of ions and water in the insect renal system, which is composed of the Malpighian tubules (*Mt*) and hindgut (*hg*). The midgut (*mg*) and foregut (*fg*) play minor roles in ion homeostasis that vary among insect taxa.

To precisely control the ionic environment of the neurons, the glial cells and the neurons themselves have high levels Na^+/K^+ -ATPase, that promotes high $[\text{Na}^+]$ and low $[\text{K}^+]$ in the nerve extracellular fluid (Figure 1.2; Kocmarek and O'Donnell, 2011; Leiserson and Keshishian, 2011; Schofield and Treherne, 1975).

Ion balance in insect muscle differs from that of the nervous system; unlike neurons, insect muscle cells are directly bathed in hemolymph. Muscle resting potential is maintained by active transport of ions across the muscle cell, sarcoplasmic and endoplasmic reticulum membranes, and is predominantly determined by the K^+ concentration gradient across the muscle cell membrane (Hoyle, 1953). In most insect groups, Na^+/K^+ -ATPase is the primary regulator of muscle resting potential, and maintains high $[\text{K}^+]$ and low $[\text{Na}^+]$ inside muscle cells (Figure 1.2; Emery et al., 1998; Fitzgerald et al., 1996). Lepidoptera differ from this typical arrangement, as they possess little Na^+/K^+ -ATPase in their muscle membranes, maintain extremely low extracellular $[\text{Na}^+]$ and instead appear to maintain K^+ gradients by an H^+ -ATPase coupled to a K^+/Cl^- co-transporter (Djamgoz, 1987; Fitzgerald et al., 1996). Action potentials in insect muscle cells initiate contraction, and are generated by an inward depolarizing Ca^{2+} current (unlike vertebrates which primarily use Na^+ for initial depolarization) and both fast and slow outwards (repolarizing) K^+ currents (Ashcroft, 1981; Ashcroft and Stanfield, 1982; Collet and Belzunces, 2007; Washio, 1972). Cell membrane Ca^{2+} -ATPase and the sarcoplasmic and endoplasmic Ca^{2+} -ATPase (SERCA) stop muscle contraction by rapidly removing Ca^{2+} from the cytoplasm and returning cytoplasmic $[\text{Ca}^{2+}]$ to resting conditions (Sanyal et al., 2006; Vázquez-Martínez et al., 2003).

1.4.2 The insect renal system

Maintenance of extracellular water and ion balance in insects is achieved by the coordinated activities of the renal system, composed of the Malpighian tubules and the hindgut. The suite of transport mechanisms involved in insect renal function is diverse, particularly in relation to the diversity of insect diets (reviewed by Beyenbach et al., 2010; O'Donnell, 2008), and are beyond the scope of this dissertation. Nonetheless, some generalizations can be made regarding the overall functions of the Malpighian tubules

and hindgut. The Malpighian tubules vary in number among insects, but are always composed of a single cell layer surrounding a tubule lumen. In some insects, such as the blood-feeding *Rhodnius prolixus* (Hemiptera: Triatominae) the tubules are composed of a single cell type, while in others (e.g. *Drosophila melanogaster*) principal and stellate cells play distinct transport roles. At the distal ends of the Malpighian tubule, transcellular transport of (primarily) Na^+ , K^+ and Cl^- drive net flux of water into the tubule lumen through transcellular (aquaporin) and/or paracellular routes, producing fluid nearly isosmotic to the hemolymph (Figure 1.2). Diffusion or coupled-transport of metabolic waste products and toxins facilitates their excretion (O'Donnell, 2008). Transport of water and ions by the Malpighian tubules is predominantly driven by V-ATPase H^+ transport, which motivates Na^+ and K^+ transport through the cells via channels or secondary transporters such as the $\text{Na}^+/\text{K}^+/\text{2Cl}^-$ co-transporter and Na^+/H^+ exchanger (Beyenbach and Wieczorek, 2006; Beyenbach et al., 2010). In *Drosophila*, Na^+/K^+ -ATPase in the basolateral (hemolymph-facing) membrane of the principal cells also plays an electrogenic role, and likely regulates the ratio of Na^+ and K^+ in the secreted fluid (Linton and O'Donnell, 1999; O'Donnell, 2008). The proximal region of the Malpighian tubules of some insects reabsorbs a small proportion of water, K^+ , and Cl^- , but the majority of fluid and ions travel through the tubule lumen to the hindgut (O'Donnell and Maddrell, 1995).

The insect hindgut reabsorbs useful solutes and water while excreting toxic waste molecules or ions that are ingested in excess (Phillips, 1964). In the posterior hindgut, active transport of Cl^- , Na^+ and K^+ (via Na^+/K^+ -ATPase and a putative Cl^- -ATPase) drive water Na^+ and Cl^- reabsorption from the gut lumen to the hemolymph (Figure 1.2; Audsley et al., 2013; Hanrahan and Phillips, 1983; Phillips et al., 1986; Phillips et al., 1996). Ions and water pass through intercellular channels, where some ions are actively transported back into the cells and reused in water transport. The arrangement of the insect renal system is energetically-demanding relative to the vertebrate nephron, but allows for rapid excretion of toxic metabolites and the production of either hypo- or hyperosmotic excreta (relative to the hemolymph) depending on the water balance state of the insect (O'Donnell, 2008).

1.5 Overview of dissertation

In this dissertation, I explore the physiological mechanisms underlying chill-coma, chill-coma recovery, and indirect chilling injury, as well as the potential mechanisms underlying plasticity and evolution of cold tolerance, in chill-susceptible insects. My primary goals in undertaking this research are: (1) to determine whether oxygen limitation on thermal tolerance underlies the insect CT_{min} in normoxia, (2) to test the hypothesis that a loss of ion balance associated with chill-coma and chilling injury of chill-susceptible insects, (3) to characterize the tissue-level patterns by which ion homeostasis is both lost in the cold and recovered following a cold stress, and (4) to determine whether variation in the mechanisms of whole-organism ion homeostasis are likely to contribute to the well-documented variation in the cold tolerance of chill-susceptible insects.

In Chapter 2, I review the current state of knowledge on the mechanisms underlying insect chill-coma. Here, I present a conceptual model of neuromuscular failure, portions of which are directly tested in the chapters that follow. I suggest how chill-coma could manifest as a result of either OCLT (as in marine animals) or alternatively through the direct effects of low temperatures on ionoregulation. I also discuss three common measures of insect cold tolerance, the CT_{min} , chill-coma and CCR in the context of shared underlying mechanisms. It is my hope that the hypotheses raised in this chapter will continue to be tested beyond the work presented in this dissertation, both by others and myself.

In Chapter 3, I use the fall field cricket (*Gryllus pennsylvanicus*) to determine whether oxygen limitation of thermal tolerance is likely to play a role in setting the insect CT_{min} . I use open-flow respirometry methods to determine if crickets continue to exchange gases in chill-coma and biochemical assays to test if the development of chilling injury is associated with the accumulation of anaerobic byproducts in this species. Here, I find that, although temperature has a strong influence on metabolic rate, crickets in chill-coma continue to exchange gases with their environment, suggesting that the tracheal system is still effective at delivering oxygen to tissues. Following long-term chill-coma, crickets maintain low levels of anaerobic byproducts and high levels of ATP. This study

contributes to a growing body of evidence that oxygen limitation theory does not hold in terrestrial animals, and makes it appear more likely that the thermal limits of insects are related to the direct effects of temperature on ion homeostasis.

In Chapter 4, I use *G. pennsylvanicus* to investigate the patterns of ion balance disruption that cause a depolarization of resting potential in muscle cells of insects during cooling and prolonged chilling. Here, I find that loss of resting potential and acquisition of cold-induced injury are not tied to ion balance failure of the muscle cells themselves. Instead, chilling causes a failure of ion homeostasis at the gut epithelia, leading to migration of Na^+ and water from the hemolymph to the gut. This migration of water elevates K^+ concentration in the remaining hemolymph, which in turn depolarizes the muscles. These findings allow for new hypotheses on the physiological mechanisms underlying chill-coma and chilling injury, and target the insect renal system as a potential driver of cold tolerance plasticity in insects.

In Chapter 5, I combine the techniques utilized in Chapters 3 and 4 to investigate the role of ion homeostasis in chill-coma recovery. Here, I focus on Na^+ and K^+ as the principal drivers of homeostatic failure and injury as a means to explain variation in CCR. Again using *G. pennsylvanicus*, I find that the most common measure of chill-coma recovery may be confounded by the effects of chilling injury. More importantly, recovery from chill-coma is coincident with the recovery of hemolymph K^+ concentration, facilitated by the active removal of Na^+ (and with it water) from the gut. Open-flow respirometry of crickets during chill-coma recovery implies that complete recovery from chill-coma is a metabolically costly endeavor, and the time-course of an overshoot in metabolic rate matches recovery of hemolymph Na^+ . This study supports the role of the gut in chilling injury and chill-coma recovery of *G. pennsylvanicus* and ties together several disparate observations of chill-coma recovery in other species, hinting at its broad applicability.

In Chapter 6, I use *Drosophila* to understand the physiology underlying variation in insect chill-susceptibility. Here, I use both phenotypic plasticity of cold tolerance (induced through acclimation) in *Drosophila melanogaster*, and variation in basal cold tolerance across 24 species of the *Drosophila* phylogeny to determine if cold tolerance

variation in *Drosophila* is associated with modulation of hemolymph ion homeostasis. I find that cold-tolerant phenotypes are associated with low hemolymph Na^+ and K^+ concentrations. Measurement of whole-body Na^+/K^+ -ATPase activity suggests that reductions in hemolymph ion balance are driven in part by reductions in the activity of this enzyme. Thus, broad patterns in hemolymph ion balance may explain variation in cold tolerance both within and among species of the *Drosophila* genus.

Collectively, the studies I present in this dissertation point to an important role of ion homeostasis in insect chill-susceptibility, and open exciting avenues of future study on the physiology setting insect thermal limits (Chapter 7). The broad applicability of the ideas presented here remains to be determined, but it is my hope that this work will either serve to inform better models of insect distribution in a changing climate, or inspire ideas that will one day do so.

1.6 Literature cited

- Addo-Bediako, A., Chown, S.L. and Gaston, K.J. (2000). Thermal tolerance, climatic variability and latitude. *Proceedings of the Royal Society B* 267: 739–745.
- Ashcroft, F.M. (1981). Calcium action potentials in the skeletal muscle fibres of the stick insect *Carausius morosus*. *The Journal of Experimental Biology* 93: 257–268.
- Ashcroft, F.M. and Stanfield, P. (1982). Calcium and potassium currents in muscle fibres of an insect (*Carausius morosus*). *The Journal of Physiology* 323: 93–115.
- Audsley, N., Jensen, D. and Schooley, D. A. (2013). Signal transduction for *Schistocerca gregaria* ion transport peptide is mediated via both cyclic AMP and cyclic GMP. *Peptides* 41: 74–80.
- Ayrinhac, A., Debat, V., Gibert, P., Kister, A.-G., Legout, H., Moreteau, B., Vergilino, R. and David, J.R. (2004). Cold adaptation in geographical populations of *Drosophila melanogaster*: Phenotypic plasticity is more important than genetic variability. *Functional Ecology* 18: 700–706.
- Bale, J. (1996). Insect cold hardiness: a matter of life and death. *European Journal of Entomology* 93: 369–382.

- Bale, J.S. (2002). Insects and low temperatures: from molecular biology to distributions and abundance. *Philosophical transactions of the Royal Society of London. Series B, Biological sciences* 357: 849–62.
- Battisti, A., Stastny, M., Netherer, S., Robinet, C., Schopf, A., Roques, A. and Larsson, S. (2005). Expansion of geographic range in the pine processionary moth caused by increased winter temperatures. *Ecological Applications* 15: 2084–2096.
- Baust, J.G. and Rojas, R.R. (1985). Insect cold hardiness: Facts and fancy. *Journal of Insect Physiology* 31: 755–759.
- Beyenbach, K.W. and Wiczorek, H. (2006). The V-type H⁺ ATPase: molecular structure and function, physiological roles and regulation. *The Journal of Experimental Biology* 209: 577–589.
- Beyenbach, K.W., Skaer, H. and Dow, J.A.T. (2010). The developmental, molecular, and transport biology of Malpighian tubules. *Annual Review of Entomology* 55: 351–374.
- Bozinovic, F., Calosi, P. and Spicer, J.I. (2011). Physiological correlates of geographic range in animals. *Annual Review of Ecology, Evolution, and Systematics* 42, 155–179.
- Cahill, A.E. (2013). How does climate change cause extinction? *Proceedings of the Royal Society B: Biological Sciences* 280: 20121890.
- Chen, I.-C., Hill, J.K., Ohlemüller, R., Roy, D.B. and Thomas, C.D. (2011). Rapid range shifts of species associated with high levels of climate warming. *Science* 333: 1024–1026.
- Chown, S.L. and Gaston, K.J. (2008). Macrophysiology for a changing world. *Proceedings of the Royal Society B: Biological Sciences* 275: 1469–1478.
- Chown, S.L., Gaston, K.J. and Robinson, D. (2004). Macrophysiology: large-scale patterns in physiological traits and their ecological implications. *Functional Ecology* 18: 159–167.
- Collet, C. and Belzunces, L. (2007). Excitable properties of adult skeletal muscle fibres from the honeybee *Apis mellifera*. *The Journal of Experimental Biology* 210: 454–464.
- Cottam, D.M., Tucker, J.B., Rogers-Bald, M.M., Mackie, J.B., Macintyre, J., Scarborough, J.A., Ohkura, H. and Milner, M.J. (2006). Non-centrosomal microtubule-organising centres in cold-treated cultured *Drosophila* cells. *Cell Motility and the Cytoskeleton* 63: 88–100.

- Crosthwaite, J.C., Sobek, S., Lyons, D.B., Bernards, M.A. and Sinclair, B.J. (2011). The overwintering physiology of the emerald ash borer, *Agrilus planipennis* Fairmaire (Coleoptera: Buprestidae). *Journal of Insect Physiology* 57: 166–173.
- Crozier, L. (2003). Winter warming facilitates range expansion: cold tolerance of the butterfly *Atalopedes campestris*. *Oecologia* 135: 648–656.
- Czajka, M.C. and Lee, R.E. (1990). A rapid cold-hardening response protecting against cold shock injury in *Drosophila melanogaster*. *The Journal of Experimental Biology* 148: 245–254.
- David, J.R., Gibert, P., Pla, E., Petavy, G., Karan, D. and Moreteau, B. (1998). Cold stress tolerance in *Drosophila*: analysis of chill coma recovery in *D. melanogaster*. *Journal of Thermal Biology* 23: 291–299.
- David, J.R., Gibert, P., Moreteau, B., Gilchrist, G.W. and Huey, R.B. (2003). The fly that came in from the cold: geographic variation of recovery time from low-temperature exposure in *Drosophila subobscura*. *Functional Ecology* 17: 425–430.
- Deutsch, C.A., Tewksbury, J.J., Huey, R.B., Sheldon, K.S., Ghalambor, C. K., Haak, D.C. and Martin, P.R. (2008). Impacts of climate warming on terrestrial ectotherms across latitude. *Proceedings of the National Academy of Sciences of the United States of America* 105: 6668–6672.
- Djamgoz, M. (1987). Insect muscle: intracellular ion concentrations and mechanisms of resting potential generation. *Journal of Insect Physiology* 33: 287–314.
- Dollo, V.H., Yi, S.-X. and Lee, R.E. Jr. (2010). High temperature pulses decrease indirect chilling injury and elevate ATP levels in the flesh fly, *Sarcophaga crassipalpis*. *Cryobiology* 60: 351–353.
- Doucet, D., Walker, V.K. and Qin, W. (2009). The bugs that came in from the cold: molecular adaptations to low temperatures in insects. *Cellular and Molecular Life Sciences* 66: 1404–1418.
- Drobnis, E.Z., Crowe, L.M., Berger, T., Anchordoguy, T.J., Overstreet, J.W. and Crowe, J.H. (1993). Cold shock damage is due to lipid phase transitions in cell membranes: a demonstration using sperm as a model. *Journal of Experimental Zoology* 265: 432–437.
- Eliason, E.J., Clark, T.D., Hague, M.J., Hanson, L.M., Gallagher, Z.S., Jeffries, K.M., Gale, M. K., Patterson, D.A., Hinch, S.G. and Farrell, A.P. (2011). Differences in thermal tolerance among sockeye salmon populations. *Science* 332: 109–112.
- Elnitsky, M.A., Hayward, S.A.L., Rinehart, J.P., Denlinger, D.L. and Lee, R.E. (2008). Cryoprotective dehydration and the resistance to inoculative freezing in the Antarctic midge, *Belgica antarctica*. *The Journal of Experimental Biology* 211: 524–530.

- Emery, A.M., Billingsley, P.F., Ready, P.D. and Djamgoz, M.B.A. (1998). Insect Na^+/K^+ -ATPase. *Journal of Insect Physiology* 44: 197–209.
- Esch, H. (1988). The effects of temperature on flight muscle potentials in honeybees and cuculiinid winter moths. *The Journal of Experimental Biology* 135: 109–117.
- Farrell, A.P., Hinch, S.G., Cooke, S.J., Patterson, D.A., Crossin, G.T., Lapointe, M. and Mathes, M.T. (2008). Pacific salmon in hot water: applying aerobic scope models and biotelemetry to predict the success of spawning migrations. *Physiological and Biochemical Zoology* 81: 697–708.
- Feder, M.E. (2007). Evolvability of physiological and biochemical traits: evolutionary mechanisms including and beyond single-nucleotide mutation. *The Journal of Experimental Biology* 210: 1653–1660.
- Fischlin, A., Midgley, G.F., Price, J.T., Leemans, R., Gopal, B., Turley, C., Roundsevell, M.D.A., Dube, O.P., Tarazona, J. and Velichico, A.A. (2007). Ecosystems, their properties, goods and services. In *Climate change 2007: Impacts, Adaptation and Vulnerability. Contribution of Working Group II to the Fourth Assessment Report of the Intergovernmental Panel on Climate Change* (ed. Parry, M. L., Canziani, O. F., Palutikof, P. J., van der Linden, P., and Hanson, C.), pp. 211–272. Cambridge: Cambridge University Press.
- Fitzgerald, E.M., Djamgoz, M.B.A. and Dunbar, S.J. (1996). Maintenance of the K^+ activity gradient in insect muscle compared in Diptera and Lepidoptera: contributions of metabolic and exchanger mechanisms. *The Journal of Experimental Biology* 199: 1857–1872.
- Folk, D.G., Hoekstra, L.A. and Gilchrist, G.W. (2007). Critical thermal maxima in knockdown-selected *Drosophila*: are thermal endpoints correlated? *The Journal of Experimental Biology* 210: 2649–2656.
- Fordyce, J.A. and Shapiro, A.M. (2003). Another perspective on the slow-growth/high-mortality hypothesis: chilling effects on swallowtail larvae. *Ecology* 84: 263–268.
- Frederich, M. and Pörtner, H.-O. (2000). Oxygen limitation of thermal tolerance defined by cardiac and ventilatory performance in spider crab, *Maja squinado*. *American Journal of Physiology. Regulatory, Integrative and Comparative Physiology* 279: R1531–R1538.
- Gamperl, A.K. and Farrell, A.P. (2004). Cardiac plasticity in fishes: environmental influences and intraspecific differences. *The Journal of Experimental Biology* 207: 2539–2550.
- Garcia, S.L., Pacheco, R.M., Rodrigues, V.L.C.C. and Mello, M.L.S. (2002). Effect of sequential heat and cold shocks on nuclear phenotypes of the blood-sucking insect, *Panstrongylus megistus* (Burmeister) (Hemiptera, Reduviidae). *Memórias do Instituto Oswaldo Cruz* 97: 1111–1116.

- Gaston, K.J. and Chown, S.L. (1999). Elevation and climatic tolerance: a test using dung beetles. *Oikos* 86: 584–590.
- Gaston, K.J., Chown, S.L., Calosi, P., Bernardo, J., Bilton, D.T., Clarke, A., Clusella-Trullas, S., Ghalambor, C.K., Konarzewski, M., Peck, L.S., et al. (2009). Macrophysiology: A conceptual reunification. *The American Naturalist* 174: 595–612.
- Gibert, P. and Huey, R.B. (2001). Chill-coma temperature in *Drosophila*: Effects of developmental temperature, latitude, and phylogeny. *Physiological and Biochemical Zoology* 74: 429–434.
- Gibert, P., Moreteau, B., Pétavy, G., Karan, D. and David, J.R. (2001). Chill-coma tolerance, a major climatic adaptation among *Drosophila* species. *Evolution* 55: 1063–1068.
- Goller, F. and Esch, H. (1990). Comparative study of chill-coma temperatures and muscle potentials in insect flight muscles. *The Journal of Experimental Biology* 150: 221–231.
- Han, E.-N. and Bauce, E. (1998). Timing of diapause initiation, metabolic changes and overwintering survival of the spruce budworm, *Choristoneura fumiferana*. *Ecological Entomology* 23: 160–167.
- Hanrahan, J. and Phillips, J.E. (1983). Mechanism and control of salt absorption in locust rectum. *American Journal of Physiology. Regulatory, Integrative and Comparative Physiology* 244: R131–R142.
- Harrison, J.F., Camazine, S., Marden, J.H., Kirkton, S.D., Rozo, A. and Yang, X. (2001). Mite not make it home: tracheal mites reduce the safety margin for oxygen delivery of flying honeybees. *The Journal of Experimental Biology* 204: 805–814.
- Hazell, S.P. and Bale, J.S. (2011). Low temperature thresholds: are chill coma and CT_{min} synonymous? *Journal of Insect Physiology* 57: 1085–1089.
- Helmuth, B., Kingsolver, J.G. and Carrington, E. (2005). Biophysics, physiological ecology, and climate change: does mechanism matter? *Annual Review of Physiology* 67: 177–201.
- Hosler, J.S., Burns, J.E. and Esch, H.E. (2000). Flight muscle resting potential and species-specific differences in chill-coma. *Journal of Insect Physiology* 46: 621–627.
- Hoyle, G. (1953). Potassium ions and insect nerve muscle. *The Journal of Experimental Biology* 30: 121–135.
- IPCC (2007a). *Climate change 2007: Synthesis report: An assessment of the intergovernmental panel on climate change.*

- IPCC (2007b). *Climate Change 2007: Synthesis report: Summary for policymakers*.
- Irwin, J.T. and Lee, R.E. (2002). Energy and water conservation in frozen vs. supercooled larvae of the goldenrod gall fly, *Eurosta solidaginis* (Fitch) (Diptera: Tephritidae). *Journal of Experimental Zoology* 292: 345–350.
- Jeong, S.-J., Ho, C.-H., Gim, H.-J. and Brown, M.E. (2011). Phenology shifts at start vs. end of growing season in temperate vegetation over the Northern Hemisphere for the period 1982–2008. *Global Change Biology* 17: 2385–2399.
- Jepsen, J.U., Hagen, S.B., Ims, R.A. and Yoccoz, N.G. (2008). Climate change and outbreaks of the geometrids *Operophtera brumata* and *Epirrita autumnata* in subarctic birch forest: evidence of a recent outbreak range expansion. *Journal of Animal Ecology* 77: 257–264.
- Johnston, I.A., Calvo, J., Guderley, H., Fernandez, D. and Palmer, L. (1998). Latitudinal variation in the abundance and oxidative capacities of muscle mitochondria in perciform fishes. *The Journal of Experimental Biology* 201: 1–12.
- Kearney, M. and Porter, W. (2009). Mechanistic niche modelling: combining physiological and spatial data to predict species' ranges. *Ecology Letters* 12: 334–350.
- Kellermann, V., Loeschcke, V., Hoffmann, A.A., Kristensen, T.N., Fløjgaard, C., David, J.R., Svenning, J.-C. and Overgaard, J. (2012). Phylogenetic constraints in key functional traits behind species' climate niches: patterns of desiccation and cold resistance across 95 *Drosophila* species. *Evolution* 66: 3377–3389.
- Klok, C.J., Sinclair, B.J. and Chown, S.L. (2004). Upper thermal tolerance and oxygen limitation in terrestrial arthropods. *The Journal of Experimental Biology* 207: 2361–2370.
- Kocmarek, A.L. and O'Donnell, M.J. (2011). Potassium fluxes across the blood brain barrier of the cockroach, *Periplaneta americana*. *Journal of Insect Physiology* 57: 127–135.
- Koštál, V. and Tollarová-Borovanská, M. (2009). The 70 kDa heat shock protein assists during the repair of chilling injury in the insect, *Pyrrhocoris apterus*. *PLoS one* 4: e4546.
- Koštál, V., Vambera, J. and Bastl, J. (2004). On the nature of pre-freeze mortality in insects: water balance, ion homeostasis and energy charge in the adults of *Pyrrhocoris apterus*. *The Journal of Experimental Biology* 207: 1509–1521.
- Koštál, V., Yanagimoto, M. and Bastl, J. (2006). Chilling-injury and disturbance of ion homeostasis in the coxal muscle of the tropical cockroach (*Nauphoeta cinerea*). *Comparative Biochemistry and Physiology B: Biochemistry and Molecular Biology* 143: 171–179.

- Lalouette, L., Košťál, V., Colinet, H., Gagneul, D. and Renault, D. (2007). Cold exposure and associated metabolic changes in adult tropical beetles exposed to fluctuating thermal regimes. *The FEBS Journal* 274: 1759–1767.
- Layne, J.R.J., Lee, R.E. and Huang, J.L. (1988). Inoculation triggers freezing at high subzero temperatures in a freeze-tolerant frog (*Rana sylvatica*) and insect (*Eurosta solidaginis*). *Canadian Journal of Zoology* 68: 506–510.
- Lee, R.E. (1991). Principles of insect low temperature tolerance. In *Insects at Low Temperature* (ed. Lee, R. E. and Denlinger, D. L.), pp. 17–36. New York: Chapman and Hall.
- Lee, R.E. and Denlinger, D.L. (2010). *Low Temperature Biology of Insects*. (ed. Denlinger, D.L. and Lee, R.E.J.) New York: Cambridge University Press.
- Lee, R.E., Chen, C. and Denlinger, D.L. (1987). A rapid cold-hardening process in insects. *Science* 238: 1415–1417.
- Lee, R.E., Damodaran, K., Yi, S.-X. and Lorigan, G.A. (2006). Rapid cold-hardening increases membrane fluidity and cold tolerance of insect cells. *Cryobiology* 52: 459–463.
- Leiserson, W.M. and Keshishian, H. (2011). Maintenance and regulation of extracellular volume and the ion environment in *Drosophila* larval nerves. *Glia* 59:1312–1321.
- Linton, S.M. and O'Donnell, M.J. (1999). Contributions of K^+Cl^- cotransport and Na^+/K^+ -ATPase to basolateral ion transport in malpighian tubules of *Drosophila melanogaster*. *The Journal of Experimental Biology* 202: 1561–1570.
- Lundheim, R. and Zachariassen, K.E. (1993). Water balance of over-wintering beetles in relation to strategies for cold tolerance. *Journal of Comparative Physiology B: Biochemical, Systemic, and Environmental Physiology* 163: 1–4.
- Marcott, S.A., Shakun, J.D., Clark, P.U. and Mix, A.C. (2013). A Reconstruction of regional and global temperature for the past 11,300 years. *Science* 339: 1198–1201.
- Marshall, K.E. and Sinclair, B.J. (2010). Repeated stress exposure results in a survival-reproduction trade-off in *Drosophila melanogaster*. *Proceedings of the Royal Society B: Biological Sciences* 277: 963–969.
- Martins, E.G., Hinch, S.G., Patterson, D.A., Hague, M.J., Cooke, S.J., Miller, K.M., Lapointe, M.F., English, K.K. and Farrell, A.P. (2011). Effects of river temperature and climate warming on stock-specific survival of adult migrating Fraser River sockeye salmon (*Oncorhynchus nerka*). *Global Change Biology* 17: 99–114.
- Mellanby, K. (1939). Low temperature and insect activity. *Proceedings of the Royal Society of London Series B* 127: 473–487.

- Melzner, F., Mark, F.C. and Pörtner, H.-O. (2007). Role of blood-oxygen transport in thermal tolerance of the cuttlefish, *Sepia officinalis*. *Integrative and Comparative Biology* 47: 645–655.
- Michaud, M.R. and Denlinger, D.L. (2004). Molecular modalities of insect cold survival: current understanding and future trends. *International Congress Series* 1275: 32–46.
- Nedvĕd, O., Lavy, D. and Verhoef, H.A. (1998). Modelling the time-temperature relationship in cold injury and effect of high-temperature interruptions on survival in a chill-sensitive collembolan. *Functional Ecology* 12: 816–824.
- Nyamukondiwa, C., Terblanche, J.S., Marshall, K.E. and Sinclair, B.J. (2011). Basal cold but not heat tolerance constrains plasticity among *Drosophila* species (Diptera: Drosophilidae). *Journal of Evolutionary Biology* 24: 1927–1938.
- O'Donnell, M. (2008). Insect excretory mechanisms. *Advances in Insect Physiology* 35: 1–122.
- O'Donnell, M.J. and Maddrell, S.H. (1995). Fluid reabsorption and ion transport by the lower Malpighian tubules of adult female *Drosophila*. *The Journal of Experimental Biology* 198: 1647–1653.
- Overgaard, J. and Sørensen, J.G. (2008). Rapid thermal adaptation during field temperature variations in *Drosophila melanogaster*. *Cryobiology* 56: 159–162.
- Overgaard, J., Andersen, J.L., Findsen, A., Pedersen, P.B.M., Hansen, K., Ozolina, K. and Wang, T. (2012). Aerobic scope and cardiovascular oxygen transport is not compromised at high temperatures in the toad *Rhinella marina*. *The Journal of Experimental Biology* 215: 3519–3526.
- Peck, L.S., Pörtner, H.-O. and Hardewig, I. (2002). Metabolic demand, oxygen supply, and critical temperatures in the Antarctic bivalve *Laternula elliptica*. *Physiological and Biochemical Zoology* 75: 123–133.
- Perry, A.L., Low, P.J., Ellis, J.R. and Reynolds, J.D. (2005). Climate change and distribution shifts in marine fishes. *Science* 308: 1912–1915.
- Petersen, A.M. and Gleeson, T.T. (2009). Skeletal muscle substrate utilization is altered by acute and acclimatory temperature in the American bullfrog (*Lithobates catesbeiana*). *The Journal of Experimental Biology* 212: 2378–2385.
- Philip, B.N., Kiss, A.J. and Lee, R.E. (2011). The protective role of aquaporins in the freeze-tolerant insect *Eurosta solidaginis*: functional characterization and tissue abundance of EsAQP1. *The Journal of Experimental Biology* 214: 848–857.
- Phillips, J. (1964). Rectal absorption in the desert locust, *Schistocerca gregaria* Forskal II. sodium, potassium and chloride. *Journal of Experimental Biology* 41: 39–67.

- Phillips, J.E., Hanrahan, J., Chamberlin, M. and Thompson, B. (1986). Mechanisms and control of reabsorption in insect hindgut. *Advances in Insect Physiology* 19: 329–434.
- Phillips, J.E., Wiens, C., Audsley, N., Jeffs, L., Bilgen, T. and Meredith, J. (1996). Nature and control of chloride transport in insect absorptive epithelia. *The Journal of Experimental Zoology* 275: 292–299.
- Pörtner, H.-O. (2001). Climate change and temperature-dependent biogeography: oxygen limitation of thermal tolerance in animals. *Naturwissenschaften* 88: 137–146.
- Pörtner, H.-O. (2002). Climate variations and the physiological basis of temperature dependent biogeography: systemic to molecular hierarchy of thermal tolerance in animals. *Comparative Biochemistry and Physiology Part A: Molecular and Integrative Physiology* 132: 739–761.
- Pörtner, H.-O. (2010). Oxygen- and capacity-limitation of thermal tolerance: a matrix for integrating climate-related stressor effects in marine ecosystems. *The Journal of Experimental Biology* 213: 881–893.
- Pörtner, H.-O. and Farrell, A. P. (2008). Physiology and climate change. *Science* 322: 690–692.
- Pörtner, H.-O. and Knust, R. (2007). Climate change affects marine fishes through the oxygen limitation of thermal tolerance. *Science* 315: 95–97.
- Pörtner, H.-O., Bennett, A.F., Bozinovic, F., Clarke, A., Lardies, M.A., Lucassen, M., Pelster, B., Schiemer, F. and Stillman, J.H. (2006). Trade-offs in thermal adaptation: the need for a molecular to ecological integration. *Physiological and Biochemical Zoology* 79: 295–313.
- Ransberry, V.E., MacMillan, H.A. and Sinclair, B.J. (2011). The relationship between chill-coma onset and recovery at the extremes of the thermal window of *Drosophila melanogaster*. *Physiological and Biochemical Zoology* 84: 553–559.
- Rinehart, J.P., Yocum, G.D. and Denlinger, D.L. (2000). Thermotolerance and rapid cold hardening ameliorate the negative effects of brief exposures to high or low temperatures on fecundity in the flesh fly, *Sarcophaga crassipalpis*. *Physiological Entomology* 25: 330–336.
- Rodgers, C.I., Armstrong, G.A.B. and Robertson, R.M. (2010). Coma in response to environmental stress in the locust: a model for cortical spreading depression. *Journal of Insect Physiology* 56: 980–990.
- Rojas, R.R. and Leopold, R.A. (1996). Chilling Injury in the housefly: evidence for the role of oxidative stress between pupariation and emergence. *Cryobiology* 33: 447–458.

- Salt, R.W. (1961). Principles of insect cold-hardiness. *Annual Review of Entomology* 6: 55–74.
- Sanyal, S., Jennings, T., Dowse, H. and Ramaswami, M. (2006). Conditional mutations in SERCA, the Sarco-endoplasmic reticulum Ca²⁺-ATPase, alter heart rate and rhythmicity in *Drosophila*. *Journal of Comparative Physiology B: Biochemical, Systemic, and Environmental Physiology* 176: 253–263.
- Schofield, P. and Treherne, J. (1975). Sodium transport and lithium movements across the insect blood-brain barrier. *Nature* 255: 723–725.
- Seebacher, F. and Franklin, C.E. (2011). Physiology of invasion: cane toads are constrained by thermal effects on physiological mechanisms that support locomotor performance. *The Journal of Experimental Biology* 214: 1437–44.
- Seeley, T.D. and Visscher, P.K. (1985). Survival of honeybees in cold climates: the critical timing of colony growth and reproduction. *Ecological Entomology* 10: 81–88.
- Seidl, M.D., Pirow, R. and Paul, R.J. (2005). Acclimation of the microcrustacean *Daphnia magna* to warm temperatures is dependent on haemoglobin expression. *Journal of Thermal Biology* 30: 532–544.
- Sinclair, B.J. (1999). Insect cold tolerance: how many kinds of frozen? *European Journal of Entomology* 96: 157–164.
- Sinclair, B.J. and Roberts, S. (2005). Acclimation, shock and hardening in the cold. *Journal of Thermal Biology* 30: 557–562.
- Sinclair, B.J., Vernon, P., Klok, C.J. and Chown, S.L. (2003). Insects at low temperatures: an ecological perspective. *Trends in Ecology and Evolution* 18: 257–262.
- Sinclair, B.J., Gibbs, A. G., Lee, W.-K., Rajamohan, A., Roberts, S.P. and Socha, J.J. (2009). Synchrotron x-ray visualisation of ice formation in insects during lethal and non-lethal freezing. *PloS one* 4: e8259.
- Sørensen, J.G. and Holmstrup, M. (2011). Cryoprotective dehydration is widespread in Arctic springtails. *Journal of Insect Physiology* 57: 1147–1153.
- Staszak, D. and Mutchmor, J. (1973). Influence of temperature on induction of chill-coma and movement of the american cockroach, *Periplaneta americana*. *Comparative Biochemistry and Physiology* 45A: 895–908.
- Stevens, M.M., Jackson, S., Bester, S.A., Terblanche, J.S. and Chown, S.L. (2010). Oxygen limitation and thermal tolerance in two terrestrial arthropod species. *The Journal of Experimental Biology* 213: 2209–2218.

- Storey, K.B. (1997). Organic solutes in freezing tolerance. *Comparative Biochemistry and Physiology Part A, Physiology* 117: 319–26.
- Storey, K.B. and Storey, J.M. (1988). Freeze tolerance: constraining forces, adaptive mechanisms. *Canadian Journal of Zoology* 66: 1122–1127.
- Storey, K.B. and Storey, J.M. (2012). Insect cold hardiness: metabolic, gene, and protein adaptation. *Canadian Journal of Zoology* 90: 456–475.
- Stork, T., Engelen, D., Krudewig, A., Silies, M., Bainton, R.J. and Klämbt, C. (2008). Organization and function of the blood-brain barrier in *Drosophila*. *The Journal of Neuroscience* 28: 587–597.
- Sunday, J.M., Bates, A.E. and Dulvy, N.K. (2011). Global analysis of thermal tolerance and latitude in ectotherms. *Proceedings of the Royal Society B: Biological Sciences* 278: 1823–1830.
- Thackeray, S.J., Sparks, T.H., Frederiksen, M., Burthe, S., Bacon, P.J., Bell, J.R., Botham, M.S., Brereton, T.M., Bright, P.W., Carvalho, L., et al. (2010). Trophic level asynchrony in rates of phenological change for marine, freshwater and terrestrial environments. *Global Change Biology* 16: 3304–3313.
- Turnock, W.J. (1993). Cold-hardiness of *Lacanobia atlantica* (Lepidoptera: Noctuidae), and a comparison with three other insect species that overwinter in the same habitat. *Canadian Journal of Zoology* 71: 1710–1714.
- Tyler, S. and Sidell, B.D. (1984). Changes in mitochondrial distribution and diffusion distances in muscle of goldfish upon acclimation to warm and cold temperatures. *Journal of Experimental Zoology* 232: 1–9.
- Turnock, W.J., Lamb, R.J. and Bodnaryk, R.P. (1983). Effects of cold stress during pupal diapause on the survival and development of *Mamestra configurata* (Lepidoptera: Noctuidae). *Oecologia* 56: 185–192.
- Vázquez-Martínez, O., Cañedo-Merino, R., Díaz-Muñoz, M. and Riesgo-Escovar, J.R. (2003). Biochemical characterization, distribution and phylogenetic analysis of *Drosophila melanogaster* ryanodine and IP₃ receptors, and thapsigargin-sensitive Ca²⁺ ATPase. *Journal of Cell Science* 116: 2483–2494.
- Vigh, L., Maresca, B. and Harwood, J.L. (1998). Does the membrane's physical state control the expression of heat shock and other genes? *Trends in Biochemical Sciences* 23: 369–374.
- Washio, H. (1972). The ionic requirements for the initiation of action potentials in insect muscle fibers. *The Journal of General Physiology* 59: 121–134.

- Williams, C.M., Marshall, K.E., MacMillan, H.A., Dzurisin, J.D.K., Hellmann, J.J. and Sinclair, B.J. (2012). Thermal variability increases the impact of autumnal warming and drives metabolic depression in an overwintering butterfly. *PLoS one* 7: e34470.
- Yi, S.-X. and Lee, R.E. Jr. (2004). In vivo and in vitro rapid cold-hardening protects cells from cold-shock injury in the flesh fly. *Journal of Comparative Physiology B: Biochemical, Systemic, and Environmental Physiology* 174: 611–615.
- Yi, S.-X. and Lee, R.E. Jr. (2011). Rapid cold-hardening blocks cold-induced apoptosis by inhibiting the activation of pro-caspases in the flesh fly *Sarcophaga crassipalpis*. *Apoptosis* 16: 249–255.
- Yi, S.-X., Moore, C.W. and Lee, R.E. Jr. (2007). Rapid cold-hardening protects *Drosophila melanogaster* from cold-induced apoptosis. *Apoptosis* 12: 1183–1193.
- Yocum, G.D., Zdarek, J., Joplin, K.H., Lee, R.E. Jr., Smith, D.C., Manter, K.D. and Denlinger, D.L. (1994). Alteration of the eclosion rhythm and eclosion behavior in the flesh fly, *Sarcophaga crassipalpis*, by a low and high temperature stress. *Journal of Insect Physiology* 40: 13–21.
- Zachariassen, K.E. and Kristiansen, E. (2000). Ice nucleation and antinucleation in nature. *Cryobiology* 41: 257–79.
- Zielinski, S. and Pörtner, H.-O. (1996). Energy metabolism and ATP free-energy change of the intertidal worm *Sipunculus nudus* below a critical temperature. *Journal of Comparative Physiology B: Biochemical, Systemic, and Environmental Physiology* 166: 492–500.
- Zipkin, E.F., Ries, L., Reeves, R., Regetz, J. and Oberhauser, K.S. (2012). Tracking climate impacts on the migratory monarch butterfly. *Global Change Biology* 18: 3039–3049.

Chapter 2

2 Physiological mechanisms of insect chill-coma

This review was published in a similar form in the *Journal of Insect Physiology* (MacMillan and Sinclair, 2011).

2.1 Introduction

Temperature thresholds affect insect performance and fitness by imposing limits on reproduction, growth and activity (Angilletta, 2009). While climate change is predicted to generally increase mean temperatures globally, it is also predicted to cause increases in the frequency of extreme events (Easterling et al., 2000), and thus the likelihood of insect body temperature crossing critical thermal limits, both high and low. As a result, there has been considerable research effort in delineating the geographic and taxonomic variation in both lethal and non-lethal thermal limits, as well as their plasticity over short and long timescales (reviewed by Angilletta, 2009).

When insects are cooled, there is a reversible cessation of movement, termed chill-coma (Semper, 1883). The chill-coma temperature (T_{cc}) is defined as the chronic exposure temperature that induces chill-coma (Mellanby, 1939). Immediately prior to the onset of chill-coma, the righting response is lost, as individuals lose the strength or coordination to stand, and this point has been termed the critical thermal minimum (CT_{min}), knockdown or cold-stupor temperature in insects (Block, 1990; David et al., 1998). If the chilling period does not result in chilling-injury, chill-coma is fully reversible upon rewarming (e.g. Gibert et al., 2001). To quantify chill-coma recovery, the time taken to recover a righting response from a standardized exposure time at a chill-coma-inducing temperature (chill-coma recovery time; CCR) is most commonly used, particularly in studies of *Drosophila* (e.g. David et al., 1998; Gibert et al., 2001; MacMillan et al., 2009a; Milton and Partridge, 2008; Anderson et al., 2005).

CT_{min} and CCR are important measures of thermal tolerance, vary considerably among insect species and populations (Gibert and Huey, 2001; Klok and Chown, 2003), and are plastic on short- and long-timescales (Gibert and Huey, 2001). In addition, CT_{min} and CCR are generally non-lethal metrics, and can therefore be ready targets for laboratory selection experiments (*e.g.* Watson and Hoffmann, 1996; Anderson et al., 2005). As such, CT_{min} and CCR have been used as measures of performance in a wide variety of insect species, and have been instrumental in erecting and testing theories about environmental constraints (Marais et al., 2009), geographic variation (Hoffmann and Watson, 1993; Sisodia and Singh, 2010), climate change (Terblanche et al., 2008) and relationships between tolerances to different environmental stressors (Bubliy and Loeschcke, 2005; Norry et al., 2007; MacMillan et al., 2009a).

Although *Drosophila* experiments have identified a handful of candidate genes or loci associated with CT_{min} or CCR (Morgan and Mackay, 2006; Telonis-Scott et al., 2009), the mechanisms underlying the processes of induction and recovery from chill-coma remain poorly understood. In this chapter, I will examine the current state of knowledge of chill-coma onset and recovery, and use whole-animal and tissue-specific findings to postulate mechanisms underlying chill-coma in insects.

2.2 Measuring chill-coma

Chill-coma is a relatively simple thing to measure: an intact insect is either in chill-coma (fails to move spontaneously or in response to a stimulus) or not. However, chill-coma is dependent on both the temperature and the time spent at that temperature, which has led to differing approaches to measurement. Mellanby (1939) defined T_{cc} as the temperature that induced chill-coma (lack of spontaneous movement) within 15 minutes of exposure. In order to more accurately determine the temperature at which failure occurred, Mutchmor and Richards (1961) and Anderson and Mutchmor (1968) recorded movement in response to gentle prodding with a probe after set times of exposure to static temperatures. Others defined T_{cc} as the lowest temperature at which 50 percent of

individuals remained active, utilizing the analytical approaches for LD₅₀ in ecotoxicology (Colhoun, 1960; Nuttall, 1970).

Recent studies of chill-coma have taken advantage of technological advances to quantify the onset of chill-coma using accurately controlled, downward temperature ramps (e.g. Gibert and Huey, 2001; Kelty and Lee, 2001; Hazell et al., 2008; Terblanche et al., 2008). These advances have resulted in the focus being shifted towards determining CT_{min}. The loss of coordinated movement such as the righting response (Gibert and Huey, 2001), clinging to a vertical surface (Huey et al., 1992) or coordinated walking (Gaston and Chown, 1999), have all been used to indicate CT_{min}. Since CT_{min} and T_{cc} measure early and late measures, respectively, of the same phenomenon, and likely share a similar underlying mechanism, these two metrics will henceforth be referred to collectively as CT_{min}.

Temperature ramping methods are rapid and convenient, better reflect the temperature changes experienced by insects in the field, and have allowed for large-scale selection experiments (e.g. Anderson et al., 2005). However, CT_{min} estimates depend on the interactive effects of both time and temperature of prior cold exposure, and phenotypic plasticity of thermal tolerance (Rako and Hoffmann, 2006). In some instances, slower ramping regimes, and thus longer experimental treatments, increase CT_{min} estimates, implying a time-dependent accumulation of detrimental changes that lead to the loss of function (Terblanche et al., 2007; Chown et al., 2009). In other instances, however, slower ramping rates appear to have either no effect (Powell and Bale, 2006) or instead decrease CT_{min} estimates (Nyamukondiwa et al., 2010), both of which imply plasticity in thermal tolerance can affect measurement of the CT_{min} (Rako and Hoffmann, 2006).

Measuring recovery from chill-coma also appears to be simple. Insects in chill-coma are warmed (often to room temperature), and the resumption of coordinated movement is observed. In practice, recovery from chill-coma also depends on the duration and temperature of cold exposure and recovery (David et al., 1998; Gibert et al., 2001; Macdonald et al., 2004; Rako and Hoffmann, 2006; Marais and Chown, 2008).

2.3 Plasticity of chill-coma

The lowest CT_{min} reported for an insect is $-16\text{ }^{\circ}\text{C}$ for *Diamesa* sp. (Diptera: Chironomidae) living on a Himalayan glacier, while under slow cooling rates adult tsetse flies (*Glossina pallidipes*, Diptera: Glossinidae) from Zambia exhibit CT_{min} as high as $21\text{ }^{\circ}\text{C}$ (Kohshima, 1984; Terblanche et al., 2007). Chill-coma recovery times vary among closely-related *Drosophila* species (ranging from 1.8 to 56 min after 16 h at $0\text{ }^{\circ}\text{C}$; Gibert et al., 2001), while CT_{min} estimates are lower, and recovery faster in temperate or high elevation populations or species than their tropical or lowland counterparts (Gaston and Chown, 1999; Hallas et al., 2002; Castañeda et al., 2005).

It is important to note that much of the differences in chill-coma among populations and species persist when *Drosophila* are reared under common-garden conditions, which implies an underlying genetic component to chill-coma (Hallas et al., 2002; Ayrinhac et al., 2004). By contrast, sub-Antarctic weevils and East African tsetse flies demonstrate little permanent population-level variation, instead, variation in CT_{min} is largely due to acclimation (Klok and Chown, 2003; Terblanche et al., 2006). Thus, it appears that genes associated with chill-coma recovery may be subject to strong selection in wild *Drosophila* populations, but that selection may be weaker, at least among populations, in other taxa. Laboratory selection studies on *Drosophila* readily increase or decrease CCR (e.g. Bertoli et al., 2010), and demonstrate that CCR is strongly heritable (33 to 46 %; Anderson et al., 2005). Lines of flies selected for shorter CCR also have improved survival following a cold shock, implying a link between CCR and acute cold tolerance (Anderson et al., 2005).

Both CT_{min} and CCR are also dependent on rearing and acclimation temperature (i.e. on the scale of days to weeks; Mellanby, 1939; Hori and Kimura, 1998; Hoffmann et al., 2005; Rako and Hoffmann, 2006). For example, Gibert and Huey (2001) found that CT_{min} decreases by $1\text{ }^{\circ}\text{C}$ for every $4\text{ }^{\circ}\text{C}$ decrease in developmental temperature in several *Drosophila* species. Also in *Drosophila*, temperature cycling and cold hardening (on the scale of minutes to hours) can result in a rapid decrease in CT_{min} (Kelty and Lee, 2001). However, similar rapid cold-hardening (RCH) treatments tend to improve survival to a cold stress, while having no effect on CCR (Rako and Hoffmann, 2006). This suggests

that phenotypic plasticity in CT_{\min} may be decoupled from CCR, or alternatively, that the mechanisms responsible for RCH are too transient to persist through the recovery phase. Such studies have been conducted over a very broad range of insects, demonstrating plasticity in chill-coma to a greater or lesser extent (e.g. Terblanche et al., 2006; Marais and Chown, 2008). However, although great strides have been made toward understanding chill-coma as a measure of cold tolerance that is ecologically relevant and under selection, the taxonomic and geographic breadth of these studies (summarized, for example, in Chown and Nicholson, 2004) has not been matched by a mechanistic understanding of the phenomenon. Without knowledge of its physiological, biochemical and genetic underpinnings, chill-coma will not become an exemplar of evolutionary physiology, and valuable predictions of the effects of environmental change on insect populations may be impeded.

2.4 Possible mechanisms underlying chill-coma in insects

2.4.1 Whole organism oxygen limitation

Pörtner and colleagues propose that in aquatic animals the respiratory and circulatory systems set limits to thermal tolerance (Oxygen- and Capacity-Limitation on thermal Tolerance - OCLT; Pörtner, 2002; 2010). OCLT proposes that thermal limits are set by an inability to effectively deliver oxygen to tissues, and that critical thermal limits are associated with a chronic transition from aerobic to anaerobic metabolism. Thus, time spent outside the thermal range results in the time-dependent accumulation of harmful anaerobic byproducts. However, oxygen-limitation may be less restrictive of insect performance than the performance of other animals. While many metazoans rely on a circulatory system to deliver oxygen from gas exchange organs to aerobically demanding tissues, insects deliver gaseous oxygen directly to these tissues via the tracheal system. The OCLT hypothesis has been tested at both high (Klok et al., 2004) and low (Stevens et al., 2010) temperatures in terrestrial isopods (which deliver oxygen through a circulatory system) and tenebrionid beetles (which have a tracheal system). Although both isopod and beetle CT_{\max} estimates decreased at very low oxygen concentrations, beetle high

temperature tolerance was less sensitive to low oxygen than that of the isopods (Klok et al., 2004; Stevens et al., 2010). Alterations in atmospheric oxygen did not affect CT_{min} estimates of either species, implying that oxygen limitation does not set lower critical limits of terrestrial arthropods (Stevens et al., 2010). Therefore, although more study is still needed, it appears unlikely that insect CT_{min} is driven by effects of temperature on whole animal respiratory or circulatory systems. Thus, in the next section of this chapter I will consider the effects of temperature on individual tissues that may set limits to activity, such as nerve and muscle.

2.4.2 Signal transmission failure

The cessation of movement that defines chill-coma is likely to be caused by failure in the ability of nerves to generate action potentials or muscles to accomplish contractions. Thus, determining the aspect of neuromuscular function that is inhibited first during chilling presents an interesting avenue of investigation of chill-coma. Rates of signal transmission are generally more strongly inhibited by the effects of low temperature on ganglionic delay ($Q_{10} = c. 3.0$) than temperature effects on conduction velocity ($Q_{10} = c. 1.7-2.0$), implying that failure of the nervous system is most likely to be driven by reductions in the rate of synaptic transmission (Staszak and Mutchmor, 1973). Rodgers et al. (2010) recently described an increase in extracellular $[K^+]$ in the neuropil of locust (*Locusta migratoria*; Orthoptera: Acrididae) metathoracic ganglia during cooling that often coincides with chill-coma onset. This secondary rapid depolarization of the nervous tissue likely occurs through activation of voltage dependent channels in response to an initial slow increase in $[K^+]$, and may occur repeatedly before failure, as both the peripheral and central nervous systems show a transient increase in firing frequency before going silent (Staszak and Mutchmor, 1973). However, both peripheral and central nerve action potentials can continue at temperatures below those that initiate leg and body tremors and the onset of chill-coma (Anderson and Mutchmor, 1968; Bradfish et al., 1982). Thus, although nerve failure does occur during low temperature exposure, the fact that nervous system activity has been observed below the whole-animal CT_{min} suggests that nerve failure alone cannot account for chill-coma onset.

The ability of insects to generate action potentials in muscle is also inhibited below species- and context- specific threshold temperatures (Esch and Bastian, 1968). Across all insect taxa studied to date, including representatives from Diptera, Lepidoptera, Hymenoptera, and Coleoptera, action potential duration in flight muscle cells increases exponentially below threshold temperatures, while action potential amplitude falls (Esch, 1988; Goller and Esch, 1990). Similar to events observed in the nervous system, a final burst of action potentials precedes chill-coma-onset, although unlike the nervous system, this final burst is followed by the complete loss of the ability to generate muscle action potentials (Esch, 1988).

The failure of signal transmission may be caused by the loss of membrane resting potentials in the muscle. When cooled, absolute resting potential of honeybee (*Apis mellifera*, Hymenoptera: Apidae) and *D. melanogaster* muscle depolarizes until the final burst of action potentials is observed at between -37 and -45 mV (Hosler et al., 2000). Once this threshold potential is reached, an inward Ca^{2+} current is likely activated, which triggers a series of muscle action potentials before the cell becomes unexcitable (Hosler et al., 2000). Intriguing avenues for future exploration include investigating the processes driving the loss of muscle cell potential, and the proximity of the loss of muscle cell excitability to whole animal estimates of the CT_{min} . However, one should use caution when considering flight muscles in such studies: flight is more sensitive to declining temperatures than walking, in part due to thermal effects on the biomechanics of flight (Lehmann, 1999; Frazier et al., 2008), and as such many insects will not fly at temperatures well above their CT_{min} (Mellanby, 1939).

Thus, there is evidence for both the nervous and muscular systems playing a role in setting lower thermal limits. If, or when, failure of the nervous system drives the onset of chill-coma it is likely through the strong effects of temperature on ionic homeostasis and the speed of synaptic transmission. Failure of muscle action potentials seems to precede chill-coma onset, and in this case a loss of cell excitability from declining cellular potential is most likely to drive the failure. Regardless of the tissue, chill-coma appears to be caused by failure of a suite of inter-dependent physiological mechanisms that make signal transmission possible and allow cells of the neuromuscular system to be excitable.

2.4.3 Disruption of ion regulation

Excitability of muscle cells and neurons relies on the constant management of ion concentrations. Tight regulation of ion distribution is key to insect low temperature survival (reviewed by Zachariassen et al., 2004). Freeze avoiding insects maintain ion distribution while supercooled at subzero temperatures, while ions equilibrate over time in frozen freeze-tolerant insects (Dissanayake and Zachariassen, 1980; Kristiansen and Zachariassen, 2001). At milder temperatures, changes in the distribution of Na^+ , K^+ , and Mg^{2+} act to dissipate muscle potentials during prolonged exposure to temperatures that cause chill-coma and chilling injury in chill-susceptible tropical cockroaches (*Nauphoeta cinerea*, Blattaria: Blaberidae; Košťál et al., 2006). The underlying mechanism of chill-coma has been ascribed to disruption of cellular ion homeostasis by several authors (Goller and Esch, 1990; Hosler et al., 2000; Sinclair et al., 2004), although the mechanisms behind this loss of ion balance remain open to speculation.

Changes in muscle cell potential during low temperature exposure have been measured directly (e.g. Goller and Esch, 1990; Hosler et al., 2000), or inferred from measuring extracellular and intracellular ion concentrations (e.g. Košťál et al., 2004; Košťál et al., 2006). The latter method is limited by the ions that are quantified, and the results of the two methods are not always consistent. Muscle cell potential (measured electrically) depolarize within minutes of exposure to temperatures that elicit chill-coma in *D. melanogaster* and *A. mellifera* (Hosler et al., 2000), while changes in extracellular $[\text{Na}^+]$, $[\text{K}^+]$ and $[\text{Mg}^{2+}]$ equivalent to a 10 mV change in resting potential in the muscles of a tropical cockroach (*N. cinerea*) only occur after several hours in chill-coma (Košťál et al., 2006). This discrepancy suggests that rapid changes in muscle potential that could drive chill-coma onset may be produced by movement of a cation that has not been directly measured (e.g. Ca^{2+}). Intracellular Ca^{2+} flux plays a role in signal transduction leading to cold sensing and the rapid cold-hardening response in an Antarctic midge (*Belgica antarctica*, Diptera: Chironomidae; Teets et al., 2008), and may be particularly sensitive to low temperatures. Cellular ion homeostasis is regulated through ion-motive pumps and channels that maintain intracellular and extracellular cation concentrations

within strict limits, particularly Na^+ , K^+ and Ca^{2+} . The cell membrane prevents most cation diffusion (at least on physiologically-relevant timescales), and also influences membrane-bound enzymes that facilitate ion movement. If a failure of ion homeostasis at low temperature is the underlying mechanism of chill-coma, the onset of chill-coma is likely due to the most cold-sensitive of the processes that maintain ion homeostasis. Low temperature exposure could disrupt: (1) primary, ATP-consuming ion pumps (2) control of movement of ions down their concentration gradients, or (3) integrity of cellular structure, leading to irreparable cellular injury. The latter is a probable cause of (irreversible) cellular cold shock (Quinn, 1985), but is unlikely to be a cause of (reversible) chill-coma.

2.4.3.1 The role of ion-motive ATPases

As reduction of ATP availability is unlikely to be a cause of chill-coma in insects (Section 2.4.1), primary ion pumping processes could be limited directly by the thermal sensitivity of enzymes. Temperature affects enzyme quaternary, tertiary, and secondary structure, as well as the weak bonds governing substrate binding (Gulevesky and Relina, 2013). These effects of temperature on enzyme function generally result in a Q_{10} between 2 and 3 (Hochachka and Somero, 1984). In contrast, diffusion of ions through channels is assumed to be largely independent of temperature, provided pathways for such movements remain open (Zachariassen et al., 2004). Below a threshold temperature, such a relationship will lead to an imbalance in the (reduced) active movement of ions and their (unchanged) passive diffusion down electrochemical gradients, leading to a loss of cell potential (Figure 2.1A).

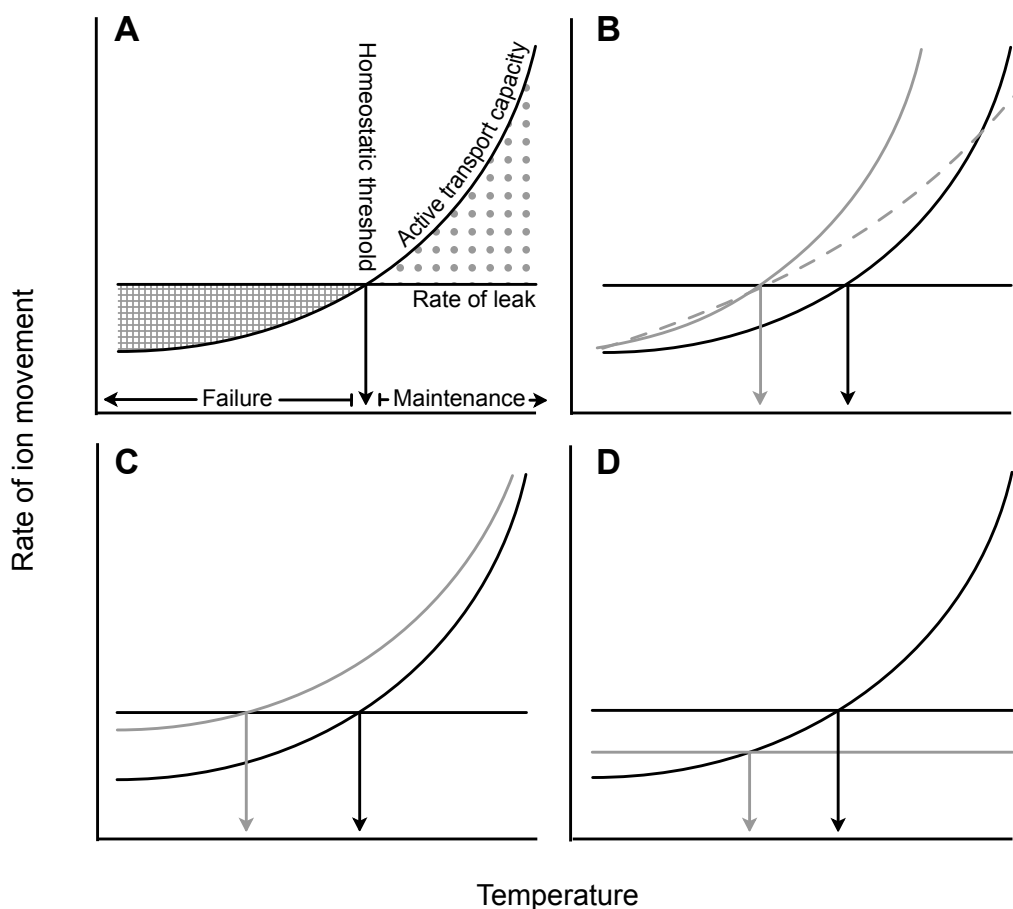

Figure 2.1. Schematics of the relationship between the capacity to actively transport ions across membranes (which has a Q_{10} between 2 and 3) and the rate of ion diffusion through available pathways (relatively unaffected by temperature; Zachariassen et al., 2004) to illustrate possible mechanisms underlying chill-coma in insects. (A) Below a threshold temperature, the rate of ion drift exceeds the capacity to actively transport the same ion (homeostatic threshold). Above this threshold, ion balance can be maintained, while below it ions will leak down their electrochemical gradient, and the rate of leak would depend upon temperature (lower temperatures having faster net leak rates). The threshold temperature could be reduced (i.e. cold tolerance improved) through several modifications to the transport-drift relationship. Such modifications (grey lines, B-D) could include (B) expression of isozymes with a lower optimal temperature (or modification of membrane fluidity; solid line) or with decreased sensitivity to low temperatures (dashed line), (C) increased expression of enzymes responsible for active transport, or (D) a reduction in the rate of ion leak through a reduction in the number of pathways available for movement.

In most metazoans, Na^+/K^+ -ATPase is the primary energy-consuming electrogenic ion pump, and accounts for a substantial proportion of organismal energy consumption (Hulbert and Else, 2000). Thermal failure of Na^+/K^+ -ATPase has been suggested as a cause of chill-coma in insects (Goller and Esch, 1990; Hosler et al., 2000; Sinclair et al., 2004). It should be noted, however, that although nervous system function is highly conserved, the extent to which insects depend on Na^+/K^+ -ATPase, and the relative contributions of major cations to ion homeostasis can vary among taxa. For example, while most insects maintain high levels of Na^+ in their hemolymph, *Rhagium inquisitor* (Coleoptera: Cerambycidae), and perhaps many other beetles, maintain high concentrations of Mg^{2+} instead (likely through activity of a Mg^{2+} pump; Dissanayake and Zachariassen, 1980). By contrast, larval Lepidoptera appear to maintain high hemolymph $[\text{K}^+]$ and low $[\text{Na}^+]$, with Na^+/K^+ -ATPase largely absent from muscle cells and electrical potential maintained by H^+/K^+ -ATPase and anion transport instead (Fitzgerald et al., 1996). If failure of muscle cell potential underlies chill-coma onset, such striking differences in ion regulation mechanisms and patterns may in part explain the strong phylogenetic signal in insect CT_{min} . For example, muscle potential was lost between -1 and 2 °C during cooling in 11 species of Lepidoptera, but above 3 °C in representatives of Hymenoptera, Diptera and Coleoptera collected from the same location in Northern Indiana, USA (Goller and Esch, 1990). The comparatively low muscle failure temperatures observed in Lepidoptera may be driven by inherent differences between the thermal sensitivity of Na^+/K^+ -ATPase and the lepidopteran ion regulation mechanisms. Thus, comparative studies of CT_{min} may benefit from taking into account the primary ion-pumping processes present in the species under study, and should account for phylogeny in both design and analysis.

Ca^{2+} -ATPase also may play an important role in mediating the effects of temperature on muscle tissue. In insects, incoming muscle action potentials activate Ca^{2+} channels, rapidly increasing cytosolic $[\text{Ca}^{2+}]$, as opposed to Na^+ in vertebrate skeletal muscle (Washio, 1972; Singh and Wu, 1999; Collet and Belzunces, 2007). Within muscle tissue, Ca^{2+} is required to permit contraction and its active sequestration from the cytosol by Ca^{2+} -ATPase is required for muscle relaxation. Calcium also initiates neurotransmitter release at synapses, and is subsequently removed from nerve terminal cytoplasm by

Ca²⁺-ATPase. If Ca²⁺-ATPases were inhibited by cooling, calcium could not be effectively removed from the cytosol, muscle fibers would cease to function, and nerve terminals would no longer be excitable, leading to the symptoms of chill-coma. At high temperatures, failure of ATP-dependent regulation of Ca²⁺ homeostasis by endoplasmic reticulum Ca²⁺-ATPase underlies thermal sensitivity of synaptic transmission in *D. melanogaster* larvae (Klose et al., 2009). Although it has thus far gone largely unstudied, Ca²⁺-ATPase may play a role in the loss of nerve and muscle excitability at low temperatures as well.

Discerning the roles of ion-motive ATPases in chill-coma onset could be accomplished by examining the effects of application of ion-pump-specific antagonists on the CT_{min}, or through correlative studies of the relationship between enzyme thermal sensitivity and CT_{min} among species or populations. Insects that demonstrate lower CT_{min} are predicted to possess pumps that have higher activity at comparatively lower temperatures, and properties of enzymes that are responsible for the onset of chill-coma may correlate strongly with the CT_{min}. Such a direction provides an opportunity to assess evolved variation in thermal tolerance at the molecular level: phenotypic plasticity in the CT_{min} (e.g. Chown and Nicholson, 2004) could be explained by variation in ion-pump structure (e.g. through differential expression of isozymes or post-translational modification; Figure 2.1B) or abundance (Figure 2.1C).

2.4.3.2 The role of ion channels

Ion channels play essential roles in the generation and propagation of ion currents of both nerve and muscle cells (Wicher et al., 2001), and while movement of ions through channels is a passive process that is independent of temperature on a biological scale (Zachariassen et al., 2004), the opening and closing of Na⁺, K⁺ and Ca²⁺ channels may be subject to the same effects of temperature as other enzymatic processes. Much of the current knowledge of the activity of ion channel gating in relation to cold has been done on the genetic level in *Drosophila*; whether ion channels play an important role in chill-coma under natural conditions has not yet been directly tested.

In *Drosophila*, the most abundant and important voltage-gated sodium channels are encoded by the gene *para* (Loughney et al., 1989). Mutations to *para* induce paralysis in adult *D. melanogaster* at both high (Suzuki et al., 1971) and low (Lilly et al., 1994; Lindsay et al., 2008) temperatures. Mutation to the human ortholog of *para* that slows inactivation of sodium channels alters the same residue that causes cold sensitive paralysis in *D. melanogaster* (Wu et al., 2005). As a result of this mutation, increased movement of Na^+ into cells from delayed inhibition would need to be countered by more rapid export of sodium by Na^+/K^+ -ATPase. Interactions between channel gating and temperature effects on Na^+/K^+ -ATPase activity may lead to a loss of ion homeostasis at relatively higher temperatures in *para* mutants. Alternatively, direct temperature effects on Na^+ channel inactivation in concert with mutation to *para* may dissipate nerve potentials, regardless of the action of ion-motive ATPases.

Voltage-sensitive K^+ channels encoded by the gene *shaker* in *D. melanogaster* are largely responsible for the repolarization phase of nerve and muscle action potentials (Covarrubias et al., 1991; Kamb et al., 1987). *Shaker* mutants have prolonged action potentials and delayed repolarization caused by reduced or lost function of outward-current K^+ channels (Lichtinghagen et al., 1990). K^+ channels are particularly temperature-sensitive in *D. melanogaster*: a reduction in temperature of only 4 °C (from 25 to 21 °C) reduces current amplitude by 25 % and increases the time to current peak from 1.0 ms to 2.2 ms; (Ryglewski and Duch, 2009). Thus, temperature-induced slowing of the opening and closing of K^+ channels may explain increased action potential duration with cooling, while combined effects on activation and inactivation of Na^+ and K^+ channels, coupled with depolarization of resting potential, could account for reduced action potential amplitude (Goller and Esch, 1990).

Although the rate at which ions can move through membranes is largely unrelated to temperature, a reduction in the number of pathways available for ion leak would cause a net reduction in ion leak across all temperatures. Thus rapid or long-term responses to low temperature exposure may include inducible reductions in ion permeability across nerve and muscle membranes through closing or sequestration of channels (Figure 2.1D). Such alterations would decrease the minimum temperature at which ion homeostasis

could be maintained, and could therefore be an underlying mechanism for plasticity in chill-coma.

2.4.3.3 The role of the membrane environment

As membrane-bound proteins, the structure (and therefore function) of both ion pumps and channels depends, in part, on the membrane in which they are inserted. The fluidity of membrane bilayers depends on temperature, and ectotherms in low temperature environments generally have high levels of membrane disorder, resulting in high fluidity at low temperatures (for review, see Hazel, 1995). Because of the role of transmembrane ion pumps and channels in determining metabolism, alterations in phospholipid fatty acid composition and cholesterol content have been proposed as a “pacemaker” of cellular metabolism (Else and Wu, 1999; Hulbert and Else, 1999). A cholesterol-augmented diet improves cold tolerance of *D. melanogaster*, and short pretreatments that enhance cold tolerance alter wholesale membrane fluidity in isolated insect cells (Shreve et al., 2007; Lee et al., 2006). Both long- (Gibert and Huey, 2001) and short-term (Overgaard et al., 2006) acclimation to low temperatures result in changes in membrane fatty acid composition (but see MacMillan et al., 2009b), and this is concordant with the effect that lowering rearing temperature has in decreasing CT_{min} in *Drosophila* (Hori and Kimura, 1998). Release of neurotransmitters at presynaptic membranes is accomplished through a coordinated cycle of vesicle exocytosis and fusion that depends on the constituent lipids of the pre-synaptic terminal (reviewed by Rohrbough and Broadie, 2005). Thus, a low temperature-induced reduction in the fluidity of presynaptic membranes would also act to delay or inhibit neurotransmission.

As membrane fluidity directly affects the activity of enzymes that reside within it, temperature induced reductions in membrane fluidity likely exacerbate the effects of temperature on ATPase activity and ion channel gating. Therefore evolutionary or phenotypic variability in insect CT_{min} could be modulated by wholesale alteration of membrane fluidity (which would alter enzyme activity/temperature curves; Figure 2.1B), although extreme changes in membrane fluidity, such as membrane phase changes, are more likely associated with irreversible chilling-injury than chill-coma.

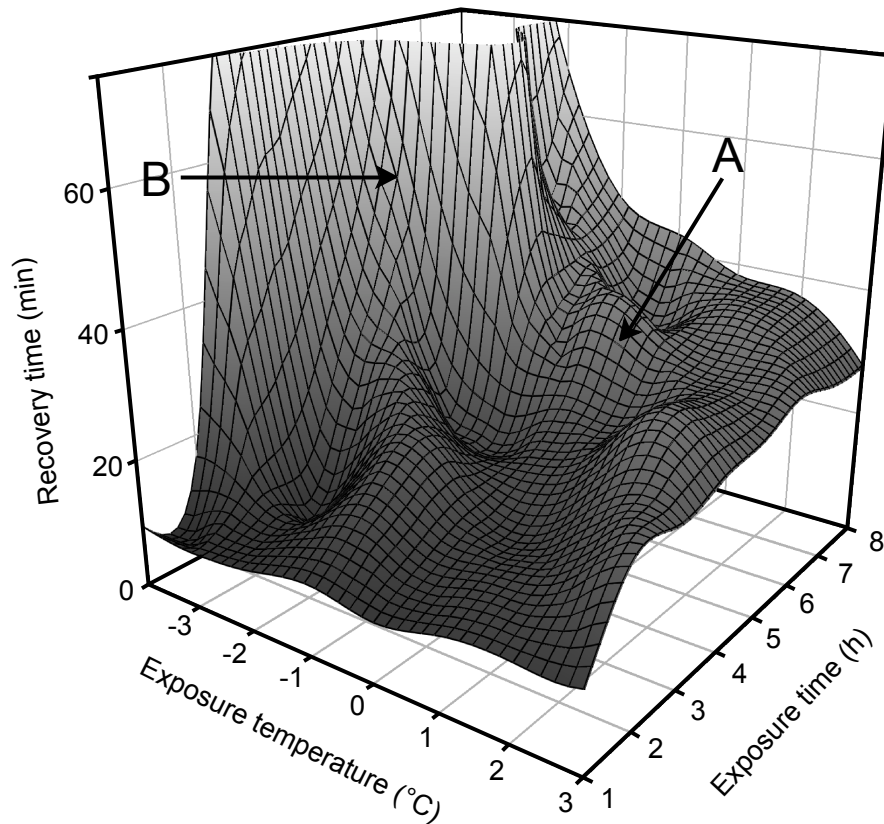

Figure 2.2: The interactive effects of cold exposure temperature and duration on chill-coma recovery time of female *Drosophila melanogaster* reared at 25 °C. Chill-coma recovery has a complex relationship with both temperature and time of cold exposure, showing a marked plateau at intermediate exposure temperatures (A). The secondary increase in recovery times (B) observed may represent a threshold level of cold exposure where chilling-injury is incurred. Data from MacDonald et al., 2004, fit using the 3D mesh plot function in Sigmaplot 10 (Systat software, Chicago, USA).

2.4.4 Mechanisms underlying chill-coma recovery

It is intuitive to assume that recovery from chill-coma involves a reversal of the mechanisms resulting in chill-coma (David et al., 1998). In reality, chill-coma recovery has a complex relationship with cold exposure temperature, as a plateau or depression in recovery times occurs following exposure to intermediate low temperatures (David et al., 2003; MacDonald et al., 2004; Terblanche et al., 2008; Figure 2.2). At relatively mild temperatures that induce chill-coma, recovery time appears to be exponential or sigmoidal in relation to exposure time, while at lower temperatures an early and steep increase in recovery time is observed (MacDonald et al., 2004; Figure 2.2). These findings suggest that at least two mechanisms underpin recovery from chill-coma; i.e. that beyond a level of cold stress (a function of both time and temperature), a secondary physiological effect of low temperature exposure acts to severely delay the ability of a fly to right itself (David et al., 2003; Macdonald et al., 2004). Chilling-injury is known to cause defects in coordination and muscle function that cannot be recovered, and is likely caused by different mechanisms than chill-coma. As chill-coma recovery is measured as the ability of an insect to right itself (a behaviour which requires coordinated movement), the sharp increase in recovery time observed from more severe cold exposures may be evidence of such injury occurring. However, much work is still needed to determine the physiological causes and ecological implications of the relationships between cold exposure duration and temperature and chill-coma recovery.

2.5 Conclusions

Much effort has been made to establish chill-coma as a useful tool for understanding insect thermal tolerance, yet much remains to be known about its physiological and genetic underpinnings. The causes of low temperature failure of insects appear to be quite different from those of other animals. Lower thermal limits in insects do not appear to be driven by failure of the respiratory and circulatory systems (Figure 2.3, box 1), but instead through disruption of signal transmission through a loss of ion homeostasis in the neuromuscular system. This failure of ion regulation may be caused by the direct effects

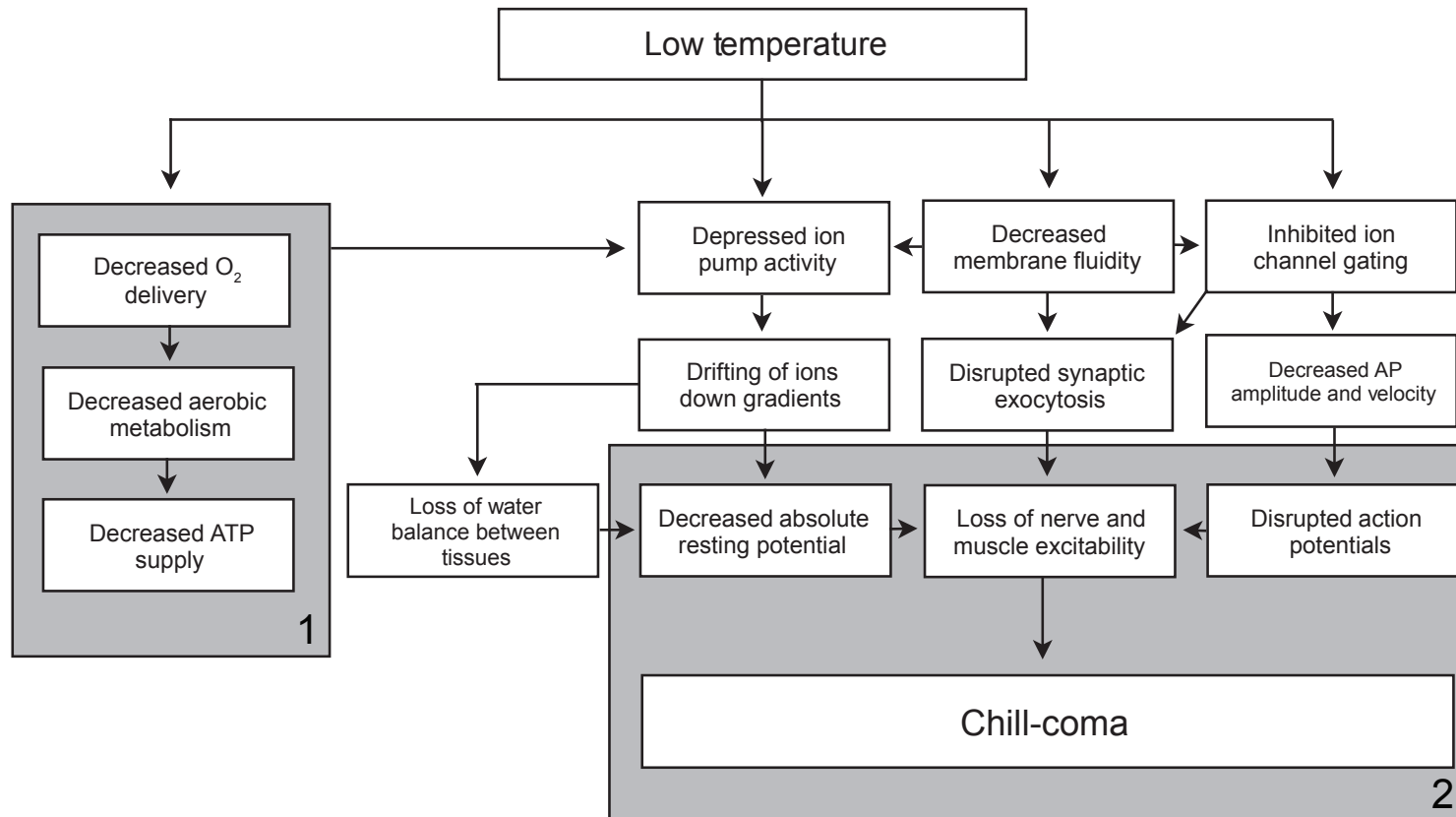

Figure 2.3. Schematic of physiological mechanisms of neuromuscular transmission failure thought to underlie insect chill-coma at low temperatures. 1: Mechanisms predicted by oxygen and capacity limited thermal tolerance (thought to occur on a whole-animal level) although current evidence suggests these are unlikely to occur in insects (see section 2.4.1). 2: Proposed mechanisms of chill-coma currently supported by empirical data. AP = action potential.

of low temperature on ion-pumps or channels, and/or through modification of membrane fluidity which influences function of all membrane bound proteins (Figure 2.3). If the ability to effectively gate ion channels is responsible for failure, disruptions to synaptic exocytosis and action potential amplitude and velocity are likely to underlie the loss of nerve and muscle excitability that has been observed at low temperatures (Figure 2.3, box 2). If a depression of ATPase activity is responsible, progressive movement of ions down their electrochemical gradients and a subsequent loss of water balance are likely to drive the loss of neuromuscular function leading to chill-coma (Figure 2.3). Elucidating the specific mechanisms responsible for chill-coma may allow for improved understanding of well-known ecological patterns. Recent advances, such as publication of the 12 *Drosophila* species genomes and high-throughput molecular screening technologies, make truly integrative studies on the interactions between genotypes, phenotypes and fitness approachable (see Dalziel et al., 2009). The physiological mechanisms underlying chill-coma are fertile ground for exciting research on these interactions.

2.6 Literature cited

- Anderson, A.R., Hoffmann, A.A. and McKechnie, S.W. (2005). Response to selection for rapid chill-coma recovery in *Drosophila melanogaster*: physiology and life-history traits. *Genetical Research* 85:15-22.
- Anderson, R.L. and Mutchmor, J.A. (1968). Temperature acclimation and its influence on the electrical activity of the nervous system in three species of cockroaches. *Journal of Insect Physiology*, 14: 243-251.
- Angilletta, M.J. (2009). Thermal adaptation: a theoretical and empirical synthesis. Oxford University Press, Oxford.
- Ayrinhac, A., Debat, V., Gibert, P., Kister, A.-G., Legout, H., Moreteau, B., Vergilino, R. and David, J.R. (2004). Cold adaptation in geographical populations of *Drosophila melanogaster*: phenotypic plasticity is more important than genetic variability. *Functional Ecology* 18: 700-706.
- Bertoli, C.I., Scannapieco, A.C., Sambucetti, P. and Norry, F.M. (2010). Direct and correlated responses to chill-coma recovery selection in *Drosophila buzzatii*. *Entomologia Experimentalis et Applicata* 134: 154-159.

- Block, W. (1990). Cold tolerance of insects and other arthropods. *Philosophical Transactions of the Royal Society of London B* 326: 613-633.
- Bradfish, G.A., Drewes, C.D. and Mutchmor, J.A. (1982). The effects of cooling on an identified reflex pathway in the cockroach (*Periplaneta americana*) in relation to chill-coma. *The Journal of Experimental Biology* 96: 131-141.
- Bubliy, O.A. and Loeschcke, V. (2005) Correlated responses to selection for stress resistance and longevity in a laboratory population of *Drosophila melanogaster*. *Journal of Evolutionary Biology* 18: 789-803.
- Castañeda, L.E., Lardies, M.A. and Bozinovic, F. (2005) Interpopulational variation in recovery time from chill coma along a geographic gradient: a study in the common woodlouse, *Porcellio laevis*. *Journal of Insect Physiology* 51: 1346-1351.
- Chown, S.L. and Gaston, K.J. (1999) Exploring links between physiology and ecology at macro-scales: the role of respiratory metabolism in insects. *Biological Reviews* 74: 87-120.
- Chown, S.L. and Nicholson, S. (2004). *Insect Physiological Ecology: Mechanisms and Patterns*. Oxford University Press, Oxford.
- Chown, S.L., Jumbam, K.R., Sørensen, J.G. and Terblanche, J.S. (2009). Phenotypic variance, plasticity and heritability estimates of critical thermal limits depend on methodological context. *Functional Ecology* 23: 133-140.
- Colhoun, E.H. (1960) Acclimatization to cold in insects. *Entomologia Experimentalis et Applicata* 3: 27-37.
- Collet, C. and Belzunces, L. (2007) Excitable properties of adult skeletal muscle fibres from the honeybee *Apis mellifera*. *The Journal of Experimental Biology* 210: 454-464.
- Covarrubias, M., Wei, A. and Salkoff, L. (1991) *Shaker*, *Shal*, *Shab*, and *Shaw* express independent K⁺ current systems. *Neuron* 7: 763-773.
- Dalziel, A.C., Rogers, S.M. and Schulte, P.M. (2009) Linking genotypes to phenotypes and fitness: how mechanistic biology can inform molecular ecology. *Molecular Ecology* 18: 4997-5017.
- David, R.J., Gibert, P., Pla, E., Petavy, G., Karan, D. and Moreteau, B. (1998). Cold stress tolerance in *Drosophila*: Analysis of chill coma recovery in *D. melanogaster*. *Journal of Thermal Biology* 23: 291-299.
- David, J.R., Gibert, P., Moreteau, B., Gilchrist, G.W. and Huey, R.B. (2003) The fly that came in from the cold: geographic variation of recovery time from low-temperature exposure in *Drosophila subobscura*. *Functional Ecology* 17: 425-430.

- Dissanayake, P. and Zachariassen, K.E. (1980). Effect of warm acclimation on the cationic concentrations in the extracellular and intracellular body fluid of hibernating *Rhagium inquisitor* beetles. *Comparative Biochemistry and Physiology A* 65: 347-350.
- Easterling, D.R., Meehl, G.A., Parmesan, C., Changnon, S.A., Karl, T.R. and Mearns, L.O. (2000) Climate extremes: observations, modeling, and impacts. *Science* 289: 2068-2074.
- Else, P.L. and Wu, B.J. (1999) What role for membranes in determining the higher sodium pump molecular activity of mammals compared to ectotherms? *Journal of Comparative Physiology B*, 169: 296-302.
- Esch, H. and Bastian, J. (1968) Mechanical and electrical activity in indirect flight muscles of the honey bee. *Zeitschrift für vergleichende Physiologie* 58: 429-440.
- Esch, H. (1988) The effects of temperature on flight-muscle potentials in honeybees and cuculiinid winter moths. *The Journal of Experimental Biology* 135: 109-117.
- Fitzgerald, E.M., Djamgoz, M.B.A. and Dunbar, S.J. (1996) Maintenance of the K⁺ activity gradient in insect muscle compared in Diptera and Lepidoptera: contributions of metabolic and exchanger mechanisms. *The Journal of Experimental Biology* 199: 1857-1872.
- Frazier, M.R., Harrison, J.F., Kirkton, S.D. and Roberts, S.P. (2008) Cold rearing improves cold-flight performance in *Drosophila* via changes in wing morphology. *The Journal of Experimental Biology* 211: 2116-2122.
- Gaston, K.J. and Chown, S.L. (1999) Elevation and climatic tolerance: a test using dung beetles. *Oikos* 86: 584-590.
- Gibert, P. and Huey, R.B. (2001) Chill-coma temperature in *Drosophila*: Effects of developmental temperature, latitude, and phylogeny. *Physiological and Biochemical Zoology* 74: 429-434.
- Gibert, P., Moreteau, B., Petavy, G., Karan, D. and David, J.R. (2001) Chill-coma tolerance, a major climatic adaptation among *Drosophila* species. *Evolution* 55: 1063-1068.
- Goller, F. and Esch, H. (1990) Comparative study of chill-coma temperatures and muscle potentials in insect flight muscles. *The Journal of Experimental Biology* 150: 221-231.
- Gulevsky, A.K., and Relina, L.I. (2013). Molecular and genetic aspects of protein cold denaturation. *CryoLetters* 34: 62–82.

- Hallas, R., Schiffer, M. and Hoffmann, A.A., (2002) Clinal variation in *Drosophila serrata* for stress resistance and body size. *Genetical Research* 79: 141-148.
- Hazel, J.R (1995) Thermal adaptation in biological membranes: is homeoviscous adaptation the explanation? *Annual Review of Physiology* 57: 19-42.
- Hazell, S.P., Pedersen, B.P., Worland, M.R., Blackburn, T.M. and Bale, J.S. (2008) A method for the rapid measurement of thermal tolerance traits in studies of small insects. *Physiological Entomology* 33: 389-394.
- Hochachka, P.W. and Somero, G.N. (1984) *Biochemical Adaptation*. Princeton University Press, Princeton.
- Hoffmann, A.A. and Watson, M. (1993) Geographical variation in the acclimation responses of *Drosophila* to temperature extremes. *The American Naturalist* 142: S93-S113.
- Hoffmann, A. A., Shirriffs, J. and Scott, M. (2005) Relative importance of plastic vs genetic factors in adaptive differentiation: geographical variation for stress resistance in *Drosophila melanogaster* from eastern Australia. *Functional Ecology* 19: 222-227.
- Hori, Y. and Kimura, M.T. (1998) Relationship between cold stupor and cold tolerance in *Drosophila* (Diptera: Drosophilidae). *Environmental Entomology* 27: 1297-1302.
- Hosler, J.S., Burns, J.E. and Esch, H.E. (2000) Flight muscle resting potential and species-specific differences in chill-coma. *Journal of Insect Physiology* 46: 621-627.
- Huey, R.B., Crill, W.D., Kingsolver, J.G. and Weber, K.E. (1992) A method for rapid measurement of heat or cold resistance of small insects. *Functional Ecology* 6: 489-494.
- Hulbert, A.J. and Else, P.L. (1999) Membranes as possible pacemakers of metabolism. *Journal of Theoretical Biology* 199: 257-274.
- Hulbert, A.J. and Else, P.L. (2000) Mechanisms underlying the cost of living in animals. *Annual Review of Physiology* 62: 207-235.
- Kamb, A., Iverson, L.E. and Tanouye, M.A. (1987) Molecular characterization of *Shaker*, a *Drosophila* gene that encodes a potassium channel. *Cell* 50: 405-413.
- Kelty, J.D. and Lee, R.E. (2001) Rapid cold-hardening of *Drosophila melanogaster* (Diptera: Drosophilidae) during ecologically based thermoperiodic cycles. *The Journal of Experimental Biology* 204: 1659-1666.

- Klok, C.J. and Chown, S.L. (2003) Resistance to temperature extremes in sub-Antarctic weevils: interspecific variation, population differentiation and acclimation. *Biological Journal of the Linnean Society* 78: 401-414.
- Klok, C.J., Sinclair, B.J. and Chown, S.L. (2004) Upper thermal tolerance and oxygen limitation in terrestrial arthropods. *The Journal of Experimental Biology* 207: 2361-2370.
- Klose, M.K., Boulianne, G.L., Robertson, R.M. and Atwood, H.L. (2009) Role of ATP-dependent calcium regulation in modulation of *Drosophila* synaptic thermotolerance. *Journal of Neurophysiology* 102: 901-913.
- Kohshima, S. (1984) A novel cold-tolerant insect found in a Himalayan glacier. *Nature* 310: 225-227.
- Košťál, V., Vambera, J. and Bastl, J. (2004) On the nature of pre-freeze mortality in insects: water balance, ion homeostasis and energy charge in the adults of *Pyrrhocoris apterus*. *The Journal of Experimental Biology* 207: 1509-1521.
- Košťál, V., Yanagimoto, M. and Bastl, J. (2006) Chilling-injury and disturbance of ion homeostasis in the coxal muscle of the tropical cockroach (*Nauphoeta cinerea*). *Comparative Biochemistry and Physiology B* 143: 171-179.
- Kristiansen, E. and Zachariassen, K.E. (2001) Effect of freezing on the transmembrane distribution of ions in freeze-tolerant larvae of the wood fly *Xylophagus cinctus* (Diptera, Xylophagidae). *Journal of Insect Physiology* 47: 585-592.
- Lee, R.E., Damodaran, K., Yi, S.-X. and Lorigan, G.A. (2006) Rapid cold-hardening increases membrane fluidity and cold tolerance of insect cells. *Cryobiology* 52: 459-463.
- Lehmann, F.O. (1999) Ambient temperature affects free-flight performance in the fruit fly *Drosophila melanogaster*. *Journal of Comparative Physiology B* 169: 165-171.
- Lichtinghagen, R., Stocker, M., Wittka, R., Boheim, G., Stühmer, W., Ferrus, A. and Pongs, O. (1990) Molecular basis of altered excitability in *Shaker* mutants of *Drosophila melanogaster*. *EMBO Journal* 9: 4399-4407.
- Lilly, M., Riesgo-Escovar, J. and Carlson, J. (1994). Developmental analysis of the *smellblind* mutants: evidence for the role of sodium channels in *Drosophila* development. *Developmental Biology* 162: 1-8.
- Lindsay, H.A., Baines, R., French-Constant, R., Lilley, K., Jacobs, H.T. and O'Dell, K.M.C. (2008) The dominant cold-sensitive *out-cold* mutants of *Drosophila melanogaster* have novel missense mutations in the voltage-gated sodium channel gene *paralytic*. *Genetics* 180: 873-884.

- Loughney, K., Kreber, R. and Ganetzky, B. (1989) Molecular analysis of the *para* locus, a sodium channel gene in *Drosophila*. *Cell* 58: 1143-1154.
- Macdonald, S.S., Rako, L., Batterham, P. and Hoffmann, A.A. (2004) Dissecting chill coma recovery as a measure of cold resistance: evidence for a biphasic response in *Drosophila melanogaster*. *Journal of Insect Physiology* 50: 695-700.
- MacMillan, H.A., Walsh, J.P. and Sinclair, B.J. (2009a) The effects of selection for cold tolerance on cross-tolerance to other environmental stressors in *Drosophila melanogaster*. *Insect Science* 16: 263-276.
- MacMillan, H.A., Guglielmo, C.G. and Sinclair, B.J. (2009b) Membrane remodeling and glucose in *Drosophila melanogaster*: a test of rapid cold-hardening and chilling tolerance hypotheses. *Journal of Insect Physiology* 55: 243-249.
- MacMillan, H. A., and Sinclair, B. J. (2011). Mechanisms underlying insect chill-coma. *Journal of Insect Physiology* 57: 12–20.
- Marais, E. and Chown, S. L. (2008) Beneficial acclimation and the Bogert effect. *Ecology Letters* 11: 1027-1036.
- Marais, E., Terblanche, J.S. and Chown, S.L. (2009) Life stage-related differences in hardening and acclimation of thermal tolerance traits in the kelp fly, *Paractora dreuxi* (Diptera, Helcomyzidae). *Journal of Insect Physiology* 55: 336-343.
- Mellanby, K. (1939) Low temperature and insect activity. *Proceedings of The Royal Society of London B* 127: 473-487.
- Milton, C.C. and Partridge, L. (2008) Brief carbon dioxide exposure blocks heat hardening but not cold acclimation in *Drosophila melanogaster*. *Journal of Insect Physiology* 54: 32-40.
- Morgan, T.J. and Mackay, T.F.C. (2006) Quantitative trait loci for thermotolerance phenotypes in *Drosophila melanogaster*. *Heredity* 96: 232-242.
- Mutchmor, J. and Richards, A. (1961) Low temperature tolerance of insects in relation to the influence of temperature on muscle apyrase activity. *Journal of Insect Physiology* 7: 141-158.
- Norry, F.M., Gomez, F.H. and Loeschke, V. (2007) Knockdown resistance to heat stress and slow recovery from chill coma are genetically associated in a quantitative trait locus region of chromosome 2 in *Drosophila melanogaster*. *Molecular Ecology* 16: 3274-3284.
- Nuttall, R.M. (1970) The effect of acclimation upon the survival of *Ptinus tectus* and *Tenebrio molitor* when exposed to low temperatures. *Entomologia Experimentalis et Applicata* 13: 217-228.

- Nyamukondiwa, C. and Terblanche, J.S. (2010) Within-generation variation of critical thermal limits in adult Mediterranean and Natal fruit flies *Ceratitis capitata* and *Ceratitis rosa*: thermal history affects short-term responses to temperature. *Physiological Entomology* 35: 255-264.
- Overgaard, J., Sørensen, J.G., Petersen, S.O., Loeschcke, V. and Holmstrup, M. (2006) Reorganization of membrane lipids during fast and slow cold hardening in *Drosophila melanogaster*. *Physiological Entomology* 31: 328-335.
- Pörtner, H.-O. (2002) Climate variations and the physiological basis of temperature dependent biogeography: systemic to molecular hierarchy of thermal tolerance in animals. *Comparative Biochemistry and Physiology A* 132: 739-761.
- Pörtner, H.-O., Bennett, A.F., Bozinovic, F., Clarke, A., Lardies, M.A., Lucassen, M., Pelster, B., Schiemer, F. and Stillman, J.H. (2006) Trade-offs in thermal adaptation: the need for a molecular to ecological integration. *Physiological and Biochemical Zoology* 79: 295-313.
- Pörtner, H.-O. (2010) Oxygen- and capacity-limitation of thermal tolerance: a matrix for integrating climate-related stressor effects in marine ecosystems. *The Journal of Experimental Biology* 213: 881-893.
- Powell, S.J. and Bale, J.S. (2006) Effect of long-term and rapid cold hardening on the cold torpor temperature of an aphid. *Physiological Entomology* 31: 348-352.
- Quinn, P.J. (1985) A lipid-phase separation model of low-temperature damage to biological membranes. *Cryobiology* 22: 128-146.
- Rako, L. and Hoffmann, A.A. (2006) Complexity of the cold acclimation response in *Drosophila melanogaster*. *Journal of Insect Physiology* 52: 94-104.
- Rodgers, C.I., Armstrong, G.A.B. and Robertson, R.M. (2010) Coma in response to environmental stress in the locust: a model for cortical spreading depression. *Journal of Insect Physiology* 56: 980-990.
- Rohrbough, J. and Broadie, K. (2005) Lipid regulation of the synaptic vesicle cycle. *Nature Reviews Neuroscience* 6: 139-150.
- Ryglewski, S. and Duch, C. (2009). *Shaker* and *shal* mediate transient calcium-independent potassium current in a *Drosophila* flight motoneuron. *Journal of Neurophysiology* 102: 3673-3688.
- Semper, C. (1883) *The Natural Conditions of Existence As They Affect Animal Life*. Kegan Paul, Trench, and Co., London.
- Shreve, S.M., Yi, S.-X. and Lee, R.E. (2007) Increased dietary cholesterol enhances cold tolerance in *Drosophila melanogaster*. *Cryoletters* 28: 33-37.

- Singh, S. and Wu, C.-F. (1999) Ionic currents in larval muscles of *Drosophila*. *International Review of Neurobiology* 43: 191-220.
- Sinclair, B.J., Klok, C.J. and Chown, S.L. (2004) Metabolism of the sub-Antarctic caterpillar *Pringleophaga marioni* during cooling, freezing and thawing. *The Journal of Experimental Biology* 207: 1287-1294.
- Sisodia, S. and Singh, B.N. (2010) Influence of developmental temperature on cold shock and chill coma recovery in *Drosophila ananassae*: acclimation and latitudinal variations among Indian populations. *Journal of Thermal Biology* 35: 117-124.
- Staszak, D.J. and Mutchmor, J.A. (1973) Influence of temperature on chill-coma and the electrical activity of the central and peripheral nervous systems of the American cockroach, *Periplaneta americana*. *Comparative Biochemistry and Physiology A* 45: 909-923.
- Stevens, M.M., Jackson, S., Bester, S.A., Terblanche, J.S. and Chown, S.L. (2010) Oxygen limitation and thermal tolerance in two terrestrial arthropod species. *The Journal of Experimental Biology* 213: 2209-2218.
- Suzuki, D.T., Grigliatti, T. and Williamson, R. (1971) Temperature-sensitive mutations in *Drosophila melanogaster*. VII. A mutation (*para-ts*) causing reversible adult paralysis. *Proceedings of the National Academy of Sciences* 68: 890-893.
- Teets, N.M., Elnitsky, M.A., Benoit, J.B., Lopez-Martinez, G., Denlinger, D.L. and Lee, R.E. (2008). Rapid cold-hardening in larvae of the Antarctic midge *Belgica antarctica*: cellular cold-sensing and a role for calcium. *American Journal of Physiology - Regulatory, Integrative and Comparative Physiology* 294: R1938-R1946.
- Telonis-Scott, M., Hallas, R., McKechnie, S.W., Wee, C. W. and Hoffmann, A.A. (2009) Selection for cold resistance alters gene transcript levels in *Drosophila melanogaster*. *Journal of Insect Physiology* 55: 549-555.
- Terblanche, J.S., Klok, C.J., Krafur, E.S. and Chown, S.L. (2006) Phenotypic plasticity and geographic variation in thermal tolerance and water loss of the tsetse *Glossina pallidipes* (Diptera: Glossinidae): implications for distribution modelling. *American Journal of Tropical Medicine and Hygiene* 74:, 786-794.
- Terblanche, J.S., Deere, J.A., Clusella-Trullas, S., Janion, C. and Chown, S.L. (2007) Critical thermal limits depend on methodological context. *Proceedings of the Royal Society B* 274: 2935-2942.
- Terblanche, J.S., Clusella-Trullas, S., Deere, J.A. and Chown, S.L. (2008) Thermal tolerance in a south-east African population of the tsetse fly *Glossina pallidipes* (Diptera, Glossinidae): implications for forecasting climate change impacts. *Journal of Insect Physiology* 54: 114-127.

- Washio, H. (1972) The ionic requirements for the initiation of action potentials in insect muscle fibers. *The Journal of General Physiology* 59: 121-134.
- Watson, M.J.O. and Hoffmann, A.A., (1996) Acclimation, cross-generation effects, and the response to selection for increased cold resistance in *Drosophila*. *Evolution* 50: 1182-1192.
- Wicher, D., Walther, C. and Wicher, C. (2001) Non-synaptic ion channels in insects - basic properties of currents and their modulation in neurons and skeletal muscles. *Progress in Neurobiology* 64: 431-525.
- Wu, F.-f., Gordon, E., Hoffman, E.P. and Cannon, S.C. (2005) A C-terminal skeletal muscle sodium channel mutation associated with myotonia disrupts fast inactivation. *The Journal of Physiology* 565: 371-380.
- Zachariassen, K.E., Kristiansen, E. and Pedersen, S.A. (2004). Inorganic ions in cold-hardiness. *Cryobiology* 48: 126-133.

Chapter 3

3 Metabolism and energy supply below the critical thermal minimum of a chill-susceptible insect

This chapter was published in similar form in *The Journal of Experimental Biology* (MacMillan et al. 2012).

3.1 Introduction

Critical thermal limits to activity and performance are used to study adaptation of ectotherms to local climates, in part because such an approach allows for bottom-up prediction of climate-driven changes in animal distribution and abundance (Chown et al., 2010). These predictions depend on a clear understanding of the physiological underpinnings of critical thermal limits. In aquatic ectotherms both the critical thermal minimum (CT_{\min}) and the critical thermal maximum (CT_{\max}) are set by an inability to supply sufficient oxygen to metabolically-demanding tissues (oxygen- and capacity-limitation of thermal tolerance [OCLT]; reviewed by Pörtner, 2010). Beyond critical thermal limits, aerobic scope decreases, causing increased reliance on anaerobic metabolism to sustain ATP production and an accumulation of harmful anaerobic byproducts (e.g. Zielinski and Pörtner, 1996). As a mechanism setting critical thermal limits, OCLT is well supported in a wide variety of water-breathing animals, including marine invertebrates (Zielinski and Pörtner, 1996; Schröder et al., 2009; Frederich and Pörtner, 2000; Lannig et al., 2008) and vertebrates (Pörtner et al., 2004; Van Dijk et al., 1999). On a broader scale, OCLT predicts the effects of elevated temperatures on fish fitness and abundance (Pörtner and Knust, 2007; Farrell et al., 2008; Martins et al., 2011) thereby suggesting a mechanism for variation in thermal tolerance among wild populations (Eliason et al., 2011). When considered together (as an oxygen supply index), environmental oxygen supply and organismal oxygen demand can provide strong predictive power for aquatic ecological patterns in a changing climate (Verberk et al., 2011). Among air-breathing terrestrial insects, critical thermal limits have been similarly

used in both theoretical and applied contexts to test hypotheses regarding variation in thermal tolerance (e.g. Klok and Chown, 2003; Terblanche et al., 2008; Nyamukondiwa and Terblanche, 2010). However, the current understanding of the physiology underlying thermal thresholds in insects lags behind that of aquatic animals.

When cooled, insect body temperatures cross the CT_{min} , defined as the temperature at which they lack the coordination to stand or cling to a surface, and are immobilized as they enter chill-coma (Hazell and Bale, 2011). Long-term exposure to temperatures below the CT_{min} result in the accumulation of injuries and eventual death (Košťál et al., 2006; Košťál and Tollarová-Borovanská, 2009). Although the precise mechanisms underlying the insect CT_{min} are not known, onset of chill-coma is associated with a disruption of neuromuscular function (Chapter 2). When cooled, muscle resting potentials of *Apis mellifera* (Hymenoptera: Apidae) and *Drosophila melanogaster* (Diptera: Drosophilidae) depolarize, and the muscles lose the ability to generate action potentials (Hosler et al., 2000). Membrane potential amplitude is expected to decrease below a threshold where the rate of ion leak exceeds the active transport capacity of cells and tissues and ions diffuse down their concentration gradients (Chapter 2). If the insect CT_{min} and/or chill-coma is caused by an inability to deliver oxygen to tissues (as predicted by OCLT), then reduced aerobic metabolism would decrease substrate (ATP) availability, and consequently lower the rate of ATP-dependent ion transport.

There are consistent changes in insect ventilation patterns at thermal limits (Lighton and Turner, 2004), which allows one to test the effects of experimental manipulation of ambient oxygen levels during heating or cooling on critical thermal limits by flow-through respirometry and optical activity detection during a temperature ramp (Lighton and Turner, 2004; Stevens et al., 2010). Using such an approach, the CT_{max} of tenebrionid beetles (*Gonocephalum simplex*, Coleoptera: Tenebrionidae), does not decrease with oxygen concentration except under extreme hypoxia (2.5 % O_2 ; Klok et al., 2004). Similarly, oxygen concentration has no effect on CT_{min} of *Tenebrio molitor* (Coleoptera: Tenebrionidae; Stevens et al., 2010). This suggests that, unlike aquatic animals, upper and lower thermal limits of terrestrial insects are not tightly linked by a common mechanism of OCLT, but are instead likely set by alternate mechanisms (Stevens et al.,

2010), consistent with wide-scale observations of decoupling of upper and lower thermal limits in insects (Addo-Bediako et al., 2000). Such experimental manipulations provide strong evidence against oxygen limitation at low temperatures in insects in the short term. However, OCLT in marine invertebrates can occur in normoxia and over periods of days, and the relationship between oxygen availability and thermal tolerance has not been examined in insects under these conditions.

The insect tracheal system delivers oxygen directly to respiring cells via diffusion combined (when the insect is active) with convective ventilation. The tracheal system delivers oxygen efficiently even at ambient oxygen levels below 10 % (Harrison et al., 2001), which means that oxygen supply to insect tissues is unlikely to be limited during low temperature exposure in normoxia. By contrast, aquatic invertebrates do not have direct delivery of oxygen and water is relatively hypoxic, due to low O₂ solubility, compared with air. Among fish and marine invertebrates, OCLT appears to be linked to sensitivity of the circulatory system. In particular, temperature affects cardiac output and the capacity for oxygen-binding pigments to bind or release molecular oxygen (Lannig et al., 2004; Melzner et al., 2007). The limiting factors that may lead to OCLT - oxygen delivery by way of oxygen-binding pigments and a circulatory system – do not occur in insects, suggesting that oxygen delivery may not be critical for aerobic metabolism in terrestrial insects in normoxia.

If the CT_{min} were set by an inability to effectively deliver oxygen to tissues (OCLT), I predicted that aerobic metabolism would fail at the CT_{min} and crickets would rely on increased anaerobic metabolism while in chill-coma. To test this, I used thermolimit respirometry on fall field crickets to characterize respiratory phenomena associated with crossing the CT_{min} and determine whether the spiracles remain open following chill-coma onset. I also quantified muscle concentrations of ATP and anaerobic end-products (lactate and alanine) during prolonged exposure to, and recovery from, a temperature below the CT_{min}.

3.2 Materials and methods

Fall field crickets (*Gryllus pennsylvanicus*) were derived from a population collected on the University of Toronto at Mississauga campus (43.3 °N, 79.4 °W) in the summer of 2004 and were reared at a constant 25°C, humidity (70 % R.H.), and photoperiod (14:10 L:D). Crickets were fed commercial rabbit feed (Little Friends Rabbit Food, Martin Mills Inc., Elmira, ON, Canada). Adult rearing and egg collection methods followed those previously described by Judge (2010). Adults were given access to 500 mL containers filled with a 4:1 mixture of fine vermiculite and sand for one-week periods to lay eggs. Eggs were stored at 4°C for three months between generations to accommodate an obligate diapause (Rakshpal, 1962). All experiments were completed on gravid adult females, approximately three weeks after the final molt.

3.2.1 Respirometry

CO₂ production and activity of individual crickets were measured using flow-through respirometry following previously described methods (Klok et al., 2004; Lighton and Turner, 2004; Williams et al., 2010). Crickets ($n=8$) were placed individually in a cylindrical glass respiration chamber (11 cm³) inside a PTC-1 temperature controlled cabinet (Sable Systems International (SSI), Las Vegas, Nevada, USA) where the temperature was held at 20 °C for 30 min, then decreased at a rate of -0.25 °C·min⁻¹ to 0 °C, where it was held for 1 h. Dry, CO₂-free air was passed through the chamber at 50 mL·min⁻¹ and flow rate was controlled by mass flow valves (Sierra Instruments, Monterey, California, USA) and a MFC-2 controller (SSI). The CO₂ and water vapour concentration of air exiting the animal chamber was determined with a Li7000 infrared gas analyzer (LiCor, Lincoln, NE, USA). Throughout the period of data collection, activity was recorded using an AD-1 infrared activity detector (SSI). The temperature of the exterior of the animal chamber (the glass on which the insect was resting) was recorded using a type-T thermocouple and TC-2000 thermocouple meter (SSI). Carbon dioxide release and activity data were collected using a UI2 interface and Expedata software (SSI) and corrected by recording an empty chamber for 10 min at the beginning and end of each run and subtracting the baseline to compensate for any instrument drift. Carbon dioxide data were corrected for the dilution of water vapour and converted

into $\dot{V}CO_2$ ($mL\ g^{-1}\ h^{-1}$) in Expedata software.

3.2.2 ATP and lactate quantification during cold exposure and recovery

The concentrations of ATP, lactate and alanine in cricket femur muscle were measured during prolonged chill-coma and chill-coma recovery as an index of energy status and reliance on anaerobic metabolism. A total of 112 crickets were placed individually into 14 mL plastic snap-top vials with lids loosely attached to allow for airflow. Crickets were exposed to a linear temperature decline from 20 °C to 0 °C at a rate of $-0.25\ ^\circ C \cdot min^{-1}$ and held at 0 °C. Once 0 °C was reached eight crickets were removed from the cold and snap-frozen whole in liquid nitrogen every 6 h for 24 h, and every 24 h thereafter up to 120 h. In order to test for effects of cold exposure on metabolism during chill-coma recovery, a subset of crickets were exposed to the same temperature ramp followed by 24 h at 0 °C before being removed to 20 °C for 5 min, 20 min, to the point of chill-coma recovery (when the animal could stand, c. 70 min) or 24 h, then snap-frozen in liquid nitrogen. Control crickets were snap-frozen directly from their rearing conditions. As a positive control for the effects of impaired aerobic respiration, 6 crickets were exposed to anoxia (N_2 gas) for 1 h at 20 °C followed by snap-freezing without further exposure to air.

Frozen crickets were dissected on an aluminum plate cooled by liquid nitrogen. For each cricket, both hind femurs were weighed and pooled to obtain a sample that was almost exclusively muscle tissue by mass. Tissue was immediately minced with scissors on ice in 1 mL of homogenization buffer (6 % w/v perchloric acid, 1 mM EDTA). Minced samples were homogenized at 4 °C with a bullet blender (Next Advance, Inc., Averill Park, NY, USA) using 1 mm glass beads and centrifuged at $20,000 \times g$ at 4 °C for 20 min. The resulting supernatant was transferred to a new microcentrifuge tube and neutralized with 480 μL of an alkaline solution (2 M KOH, 0.4 M Imidazole, 0.3 M KCl). Samples were centrifuged again for 5 min to remove the resulting precipitate and the supernatant was stored at -80 °C until use in biochemical assays.

ATP was quantified using an ATP-determination bioluminescence kit (Invitrogen Canada Inc., Burlington, ON, Canada), which quantifies sample ATP concentration from the rate

of ATP-dependent light production by firefly luciferase (EC number: 1.13.12.7, Invitrogen Canada Inc.). Light production was quantified at 22 °C using a Sirius single-tube luminometer (Berthold Systems Inc., Pforzheim, Germany), and sample ATP concentration determined by comparison to standards of known ATP concentration.

L-lactate was quantified in 96-well assay plates using lactate dehydrogenase (EC number: 1.1.1.27, Sigma Aldrich Canada Ltd., Oakville, ON, Canada) in an NADH-linked enzymatic assay (Noll, 1984) using a Spectramax M2e spectrophotometer (Molecular Devices LLC, Sunnyvale, CA, USA), with sample concentrations determined from standard curves of known lactate concentrations. L-alanine was quantified in the same manner, but using alanine transaminase (EC number: 2.6.1.2) in an alternate NADH-linked assay (Williamson, 1990).

3.2.3 Data analysis

Respirometry data were managed in Expedata and statistical analyses were conducted with R version 2.13 (R Development Core Team, 2011). Thermolimit respirometry estimates of the CT_{min} , identified as a cessation of activity or spiracular control, were determined from the respirometry data as has been previously described (Lighton and Turner, 2004; Stevens et al., 2010). Briefly, absolute difference sums (ADS; a cumulative sum of absolute differences between consecutive data points) of cricket activity (a unitless measure) and $\dot{V}CO_2$ were calculated using the ADS function in Expedata. Five-minute periods surrounding the cessation of spiracular control ($\dot{V}CO_2$) and activity were selected manually and the ADS regressed against time. The highest five consecutive residuals of the regression were selected and the mean temperature at the inflection point of activity (aADS) or $\dot{V}CO_2$ (vADS), which were considered as two separate estimates of CT_{min} , recorded. Stevens et al. (2010) also used the final burst of CO_2 prior to the cessation of activity as a third method of estimating the CT_{min} . However, in *G. pennsylvanicus* the final burst of CO_2 was indistinguishable from the bursts that preceded it (Figure 3.1), so this method was not used. The aADS and vADS CT_{min} values for each cricket were compared using a paired t-test. The estimates of CT_{min} derived from aADS and vADS did not significantly differ (see results), thus aADS-derived CT_{min} was used in

subsequent analyses.

The slope of the activity ADS provides an index of activity level (Lighton and Turner, 2004), so aADS slopes and $\dot{V}CO_2$ from the duration of the temperature ramp (excluding the holds at 20 °C and 0 °C) were binned into 1 °C increments to estimate the thermal dependence of CO₂ release and activity. Because each cricket had a different CT_{min}, binning of $\dot{V}CO_2$ data directly by temperature did not allow for estimation of the magnitude effect of crossing the CT_{min} on the proportional rate of CO₂ release. To make such an estimate, $\dot{V}CO_2$ data were shifted such that temperatures were expressed as a positive or negative value relative to the CT_{min} of the individual cricket (such that 0 represents the CT_{min}). I then corrected for the resulting shift in the rate-temperature curve by expressing mass-specific rates of CO₂ release proportional to the average rate of each individual at 20 °C (Figure 3.2B).

I then examined the thermal sensitivity of metabolic rate before and after the CT_{min}. Rates of CO₂ release from each individual cricket were split into three stages of cooling, and Q₁₀ values over those temperature ranges determined as $10^{(10 \times \text{slope})}$ of a line of best fit of $\log_{10}(\dot{V}CO_2)$ regressed against temperature. The first segment, from 15 °C to 0.5 °C above the CT_{min} of each individual (determined from activity ADS data), was used to examine the effect of temperature on $\dot{V}CO_2$ above the CT_{min}. The second segment, from 0.5 °C below the CT_{min} of each individual to the chill-coma temperature of 2.3 °C determined from visual observation (see Chapter 4), represented the effect of temperature on the $\dot{V}CO_2$ between the CT_{min} and chill-coma onset. The last period, from 2.3 °C to the end of the temperature ramp (0 °C), represents the effect of further temperature decline on $\dot{V}CO_2$ release while in chill-coma. Q₁₀ values from different periods of the temperature ramp were compared using a repeated measures ANOVA using the lme() function of the nlme package in R. The effects of 1 h anoxia, cold exposure duration and recovery time following 24 h at 0 °C on muscle metabolite quantity were independently analyzed using the lm() function (Pinheiro et al., 2009) with tissue mass treated as a covariate in all cases. As tissue mass was always a significant covariate ($P < 0.05$), only parameters from exposure or recovery time are reported. All values reported are mean \pm 1 sem.

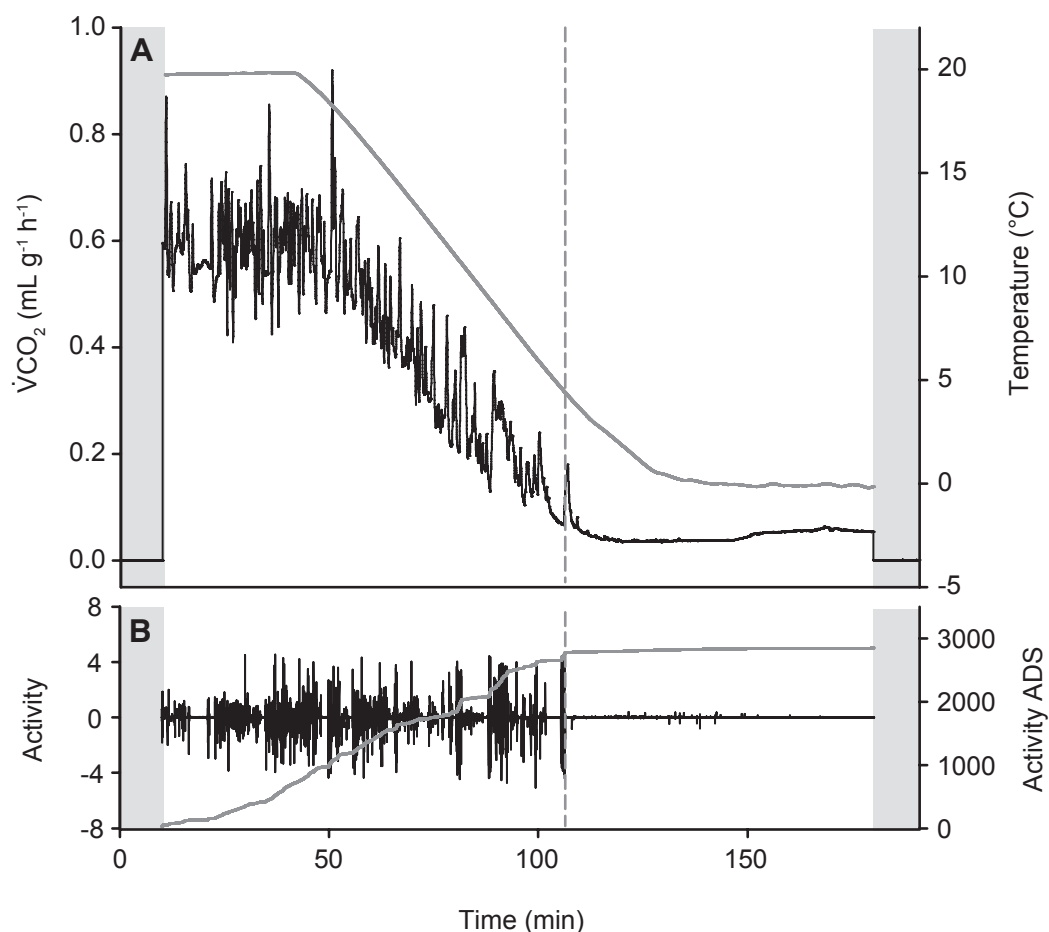

Figure 3.1. An example of respirometry and activity data from one adult female *Gryllus pennsylvanicus* during a temperature ramp. (A) CO₂ emission (black line) and temperature (gray line) (B) activity (black line), and activity absolute difference sum (ADS; gray line) while maintained at 20 °C for 1 h, and during cooling from 20 °C to 0 °C at 0.25 °C min⁻¹. Vertical gray bands at each end of the trace indicate the baseline recording from an empty chamber (activity omitted). The dotted vertical line indicates the CT_{min} temperature determined as the point of highest residuals of a regression of activity ADS over time (see methods for details).

3.3 Results

A representative respirometry trace is presented in Figure 3.1. All crickets displayed continuous respiratory patterns without discontinuous or cyclic gas exchange. Rates of CO₂ release were stable at 20 °C (before the temperature ramp began) and decreased with decreasing temperature. Activity was often detected in concert with spikes in CO₂ release, indicating that the activity detector was likely recording abdominal contractions (active ventilation). Activity was detected throughout the temperature ramp until ceasing completely at an individual-specific threshold temperature (dashed line on Figure 3.1).

Thermolimit respirometry estimates of the CT_{min} determined by the aADS method (6.5 ± 0.5 °C) and vADS method (6.2 ± 0.4 °C) did not significantly differ ($t_7=1.48$, $P=0.183$). CT_{min} estimates obtained by aADS were broadly distributed between 4.3 and 8.6 °C (Figure 3.2a). When expressed as a proportional rate of CO₂ release at temperatures relative to the aADS CT_{min} (see methods for details), the rate of CO₂ release dropped by approximately 44 % between the CT_{min} and 1 °C below the CT_{min} (Figure 3.2B).

Temperature coefficient (Q_{10}) values above the aADS CT_{min} (3.3 ± 0.3) did not significantly differ from those between the aADS CT_{min} and whole-organism chill-coma onset (3.4 ± 0.6 , $t_{10}=0.23$, $P=0.822$). However, the Q_{10} of $\dot{V}CO_2$ below the chill-coma onset temperature was 1.5 ± 0.2 , significantly lower than the Q_{10} above 2.3 °C ($t_{10}=2.87$, $P=0.016$).

Following prolonged (120 h) exposure to 0 °C, muscle [ATP] increased slightly but significantly from 8.4 ± 0.6 $\mu\text{mol}\cdot\text{g}^{-1}$ to 10.5 ± 0.5 $\mu\text{mol}\cdot\text{g}^{-1}$ ($F_{2,55}=19.02$, $P<0.001$; Figure 3.3A).

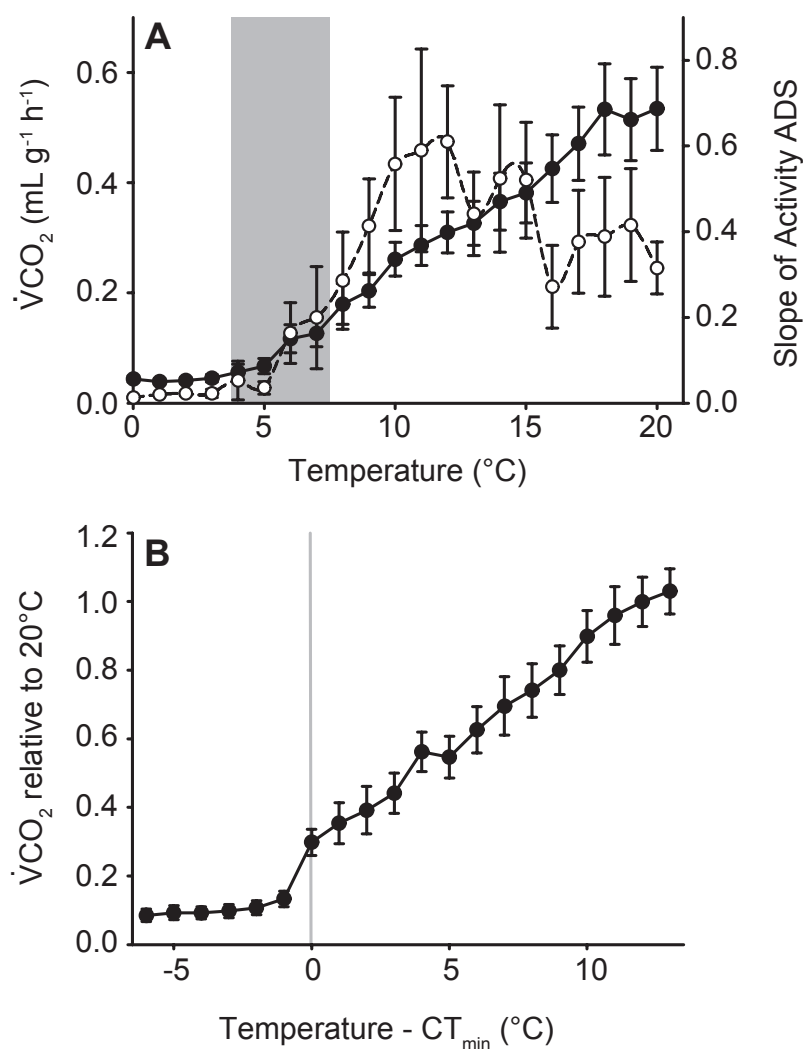

Figure 3.2. CO₂ release and slope of activity absolute difference sum (ADS) of female *Gryllus pennsylvanicus* during a linear temperature ramp from 20°C to 0°C at 0.25°C min⁻¹. Data for each cricket were averaged at 1°C increments. (A) Data expressed as mass-specific rate of CO₂ release (filled circles) and slope of activity ADS (open circles). The shaded region covers the range of temperatures over which individual crickets crossed their aADS CT_{min} (see text for details). (B) The same $\dot{V}CO_2$ data as (A), standardized to individual CT_{min} (such that 0 represents the CT_{min}, vertical gray line) and individual metabolic rate at 20°C (see methods for details). Values are means (\pm s.e.m), $n=8$ crickets.

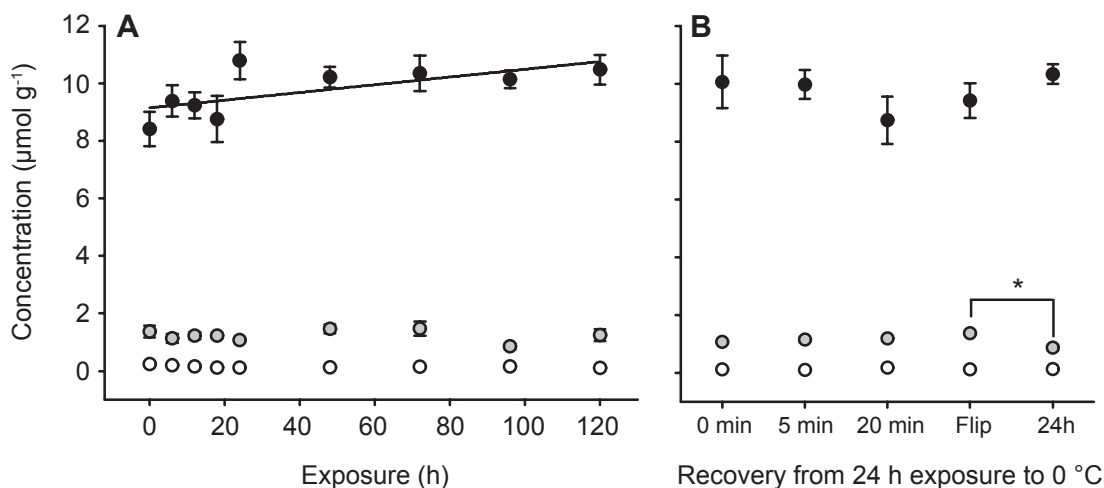

Figure 3.3. Concentrations of ATP (black), lactate (white) and alanine (gray) in the hind femur of female adult *Gryllus pennsylvanicus* (A) during exposure to 0 °C and (B) during recovery at 20 °C from 24 h in chill-coma at 0°C. Crickets recovering from 24 h at 0°C were removed to 20 °C for 5 min, 20 min, to the point of chill-coma recovery (when the cricket flipped onto its feet; Flip) or for 24 h (with access to food and water *ad libitum*) prior to sampling. Values are means (\pm sem) for $n=8$ crickets per sampling period. Error bars that are not visible are obscured by the symbols. ATP concentration significantly increased during cold exposure (linear regression; $P<0.001$). Asterisk denotes a significant difference in alanine concentration between the point crickets could stand and 24 h following removal from 0 °C (Tukey's HSD; $P=0.003$). No other significant changes in ATP, lactate or alanine concentrations were observed during cold exposure or recovery.

Low temperature exposure had no significant effect on muscle lactate ($F_{2,52}=1.32$, $P=0.256$; Figure 3.3A) or alanine ($F_{2,52}=0.22$, $P=0.641$; Figure 3.3A) concentrations. No significant changes in muscle ATP ($F_{4,21}=0.49$, $P=0.488$) or lactate ($F_{4,21}=0.13$, $P=0.717$) occurred during recovery from 24 h at 0 °C (Figure 3.3B). Following 24 h of recovery, muscle alanine was significantly lower than when measured at the point that crickets could stand ($F_{4,25}=5.45$, $P=0.003$; Figure 3.3B). No other significant differences were found in muscle [alanine] during recovery.

During one hour of hypoxia at 20 °C, muscle [ATP] decreased significantly from 8.4 ± 0.60 to 1.8 ± 0.8 $\mu\text{mol g}^{-1}$ ($F_{2,9}=21.35$, $P=0.002$; Figure 3.4), while muscle [lactate] significantly increased from 0.23 ± 0.04 to 0.31 ± 0.03 $\mu\text{mol g}^{-1}$ ($F_{2,9}=9.54$, $P=0.013$). While alanine was detectable in muscles of control and cold-exposed crickets, muscle alanine was below detectable levels in five of six anoxia-exposed crickets, and low in the sixth (0.89 $\mu\text{mol g}^{-1}$).

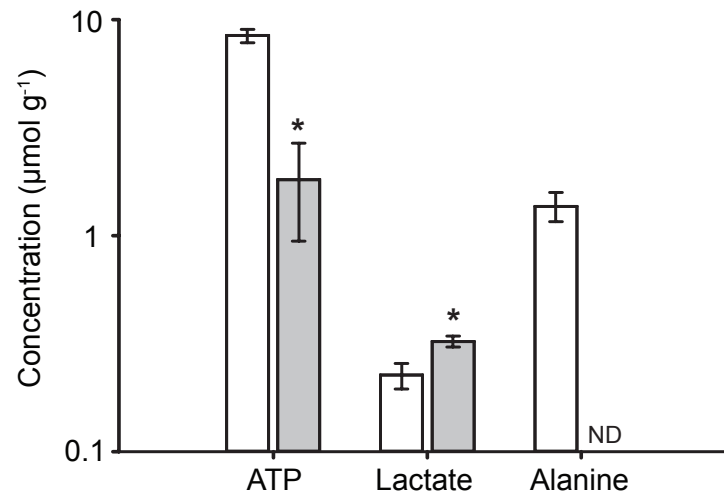

Figure 3.4. Concentrations of ATP, lactate and alanine in the hind femur of female adult *Gryllus pennsylvanicus* under normoxic conditions (white bars) and following 1h of anoxia at 20 °C (gray bars). ATP concentration significantly decreased ($P=0.002$), lactate concentration significantly increased ($P=0.013$), and alanine concentration fell below detectable levels (ND) during exposure to anoxia.

3.4 Discussion

During a linear temperature decline, crickets ceased activity at individual-specific temperatures in a manner consistent with the CT_{min} (Hazell and Bale, 2011). Below this threshold, crickets did not actively ventilate, but released CO_2 continuously, typical of insects exposed to temperatures beyond critical thermal limits or anoxia (Sinclair et al., 2004; Lighton and Schilman, 2007; Lighton and Turner, 2004; Kovac et al., 2007; Stevens et al., 2010). These thermolimit respirometry estimates of CT_{min} were higher and more variable than those determined as the complete absence of movement in response to a stimulus (2.3 ± 0.1 °C) by crickets from the same population. Estimates of CT_{min} often differ by several degrees among methods (Terblanche et al., 2007), and thermolimit respirometry also yielded significantly higher CT_{min} estimates than visual methods in a tenebrionid beetle (*Tenebrio molitor*, Coleoptera: Tenebrionidae) and a terrestrial isopod (*Porcellio scaber*, Porcellionidae; Isopoda) under similar conditions (Stevens et al., 2010). In *Periplaneta americana* (Blattaria: Blattidae), movement of the coxae can continue at temperatures several degrees below the arrest of many other regions occurs (Staszak and Mutchmor, 1973), possibly because thermal sensitivity of the nerves and muscles servicing the abdomen and limbs differ, and this could explain why crickets could continue to move their limbs to a lower temperature. However, estimates of CT_{min} determined by activity (aADS) did not differ significantly from those determined from ventilation (vADS), meaning all movement ceased when the crickets ceased control of ventilation in the respirometry chamber. This suggests that if the crickets remain untouched (as in the respirometry chamber), rather than being pestered by a scientist with a stick, all voluntary movement ceases with the cessation of ventilation, although the ability to move the limbs in response to stimulation is not yet lost. As such, thermolimit respirometry may better estimate limits to mobility in the wild than CT_{min} determination methods that require an operator to prod the insect under study. These results highlight the importance of establishing consistent terminology regarding the sequence of events leading to chill-coma (discussed extensively by Hazell and Bale, 2011).

Upon falling below the thermolimit respirometry CT_{min} , there was an abrupt decline in the rate of CO_2 release by *G. pennsylvanicus*. A similar breakpoint occurs at the CT_{min} of

the sub-Antarctic caterpillar, *Pringleophaga marioni* (Lepidoptera: Tineidae), during cooling and has been suggested to reflect kinetic failure of ATP-dependent enzymes maintaining ionic homeostasis (Sinclair et al., 2004). While I cannot rule out that this reduction in metabolic rate is related to changes in the metabolic supply of ATP, its magnitude is such that it may also be explained by cessation of the metabolic demands of neuromuscular processes. For example, when an insect crosses its CT_{min} and enters chill-coma, it no longer maintains posture, ventilation or gut motility. It is also difficult to determine whether thermolimit respirometry at low temperatures identifies physiological failure of the ventilatory system, or a behaviour (the complete cessation of movement) in response to declining temperatures, which may have higher inter-individual variation than physiological failure of the neuromuscular system (Chown et al., 2009; Stevens et al., 2010). Indeed, coma in response to environmental stress could be adaptive, as it may act to protect against cellular damage (Rodgers et al., 2010). Temperature sensors are present in the third antennal segment and brain of *Drosophila* (Hamada et al., 2008). Future studies could assess if the CT_{min} represents a direct consequence of temperature, or a response to it, by testing the effects of excision of thermosensors on thermolimit respirometry estimates of the CT_{min} .

Although the rate of CO_2 release by *G. pennsylvanicus* was low in chill-coma, it was clearly above baseline levels, suggesting that the spiracles were open, and that CO_2 and O_2 were being exchanged with the environment. Should the crickets in the current study have been oxygen limited while in chill-coma, I predicted that ATP availability would decline at the onset of chill-coma and remain low, accompanied by accumulation of anaerobic end-products. From other studies on terrestrial insects, I predicted lactate and alanine to be the primary end-products of anaerobic metabolism in crickets (Hoback et al., 2000; Hoback and Stanley, 2001; Feala et al., 2007). During prolonged chill-coma, however, muscle ATP concentrations significantly increased, and no increase in lactate or alanine concentration was observed over the same period. Even when maintained at 0 °C for five days, which results in 100 % mortality in this species (see Chapter 4), no increases in muscle [lactate] or [alanine] were observed. This is in stark contrast to the effects of anoxia, which decreased muscle ATP levels by 79 %, increased muscle

[lactate] by 35 % within 1h at 20 °C. These results support the notion that cold exposure and anoxia differ in their effects on aerobic and anaerobic metabolism.

Although the increase in ATP during cold exposure was statistically significant, it was small (25 % over 5 days) in magnitude, and may not represent a biologically significant change. An accumulation of ATP following cold exposure has been noted in the chill-susceptible beetle *Alphitobius diaperinus* (Coleoptera: Tenebrionidae; Colinet, 2011). Accumulation of ATP suggests that processes utilizing ATP (such as ion-motive enzymes) are slowed to a greater extent than oxidative phosphorylation. In contrast, total adenylate energy charge in the fat body cells of *Pyrrhocoris apterus* (Hemiptera: Pyrrhocoridae) were unchanged during long-term cold exposure (Košťál et al., 2004). Disruption of metabolic processes is a common consequence of cold exposure, and ATP-producing pathways are targets for differential regulation in response to thermal challenges (Overgaard et al., 2007). Following removal from the cold and recovery from chill-coma, no change in ATP or lactate concentrations was noted. Thus, crickets do not likely rely on anaerobic metabolism to provide energy during long-term cold exposure that is known to cause injury, or the rewarming and chill-coma recovery.

Organisms faced with environmental stress often demonstrate reduced thermal sensitivity of metabolism (Makarieva et al., 2006). To test for differences in thermal sensitivity of metabolic rate surrounding the thermolimit respirometry CT_{min} and the complete inability to move, I calculated temperature coefficients (Q_{10}) in three separate regions of the temperature ramp for each individual. The mean Q_{10} of cricket CO_2 emission prior to crossing the thermolimit respirometry CT_{min} was approximately 3, and did not differ significantly from Q_{10} values from below this breakpoint down to the chill-coma temperature of 2.3 °C. Thus, metabolic rate remains temperature-sensitive beyond the cessation of ventilation and voluntary movement. Interestingly, between 2.3 °C (the point at which crickets cease responding to physical stimulation; Chapter 4) and 0 °C, the average Q_{10} significantly decreased to 1.5, indicating that rates of CO_2 emission are less temperature-sensitive below the temperature at which no movement can be elicited from a cricket. Similarly, honeybees demonstrate low rates of CO_2 emission that are largely temperature-independent while in chill-coma (Lighton and Lovegrove, 1990), and

animals that exhibit minimum life-supporting metabolic rates during times of stress have an average Q_{10} of metabolic rate of 1.1 (relatively close to the Q_{10} of 1.5 observed during chill-coma; Makarieva et al., 2006). However, why metabolic rate would be less dependent on temperature when insects are in chill-coma is not immediately clear. Unlike those under normoxic conditions, animals in anoxia on average maintain a relatively normal Q_{10} of 2.75 (Makarieva et al., 2006), which further supports that crickets in chill-coma were not oxygen-limited.

Oxygen- and capacity-limitation of thermal tolerance is widely supported in aquatic ectotherms and has provided a useful conceptual framework for investigating the effects of environmental temperature on species abundance (Pörtner, 2010). I, however, found no evidence that crickets lack adequate oxygen when in chill-coma up to the point of death. I therefore posit that the insect CT_{min} is more likely to be set by the direct effects of temperature on reaction rates of ionoregulatory enzymes such as Na^+/K^+ -ATPase.

3.5 Literature cited

- Addo-Bediako, A., Chown, S.L. and Gaston, K.J. (2000) Thermal tolerance, climatic variability and latitude. *Proceedings of the Royal Society B* 267: 739-745.
- Chown, S.L., Jumbam, K.R., Sørensen, J.G. and Terblanche, J.S. (2009) Phenotypic variance, plasticity and heritability estimates of critical thermal limits depend on methodological context. *Functional Ecology* 23: 133-140.
- Chown, S.L., Hoffmann, A.A., Kristensen, T.N., Angilletta Jr, M.J., Stenseth, N.C. and Pertoldi, C. (2010) Adapting to climate change: a perspective from evolutionary physiology. *Climate Research* 43: 3-15.
- Colinet, H. (2011) Disruption of ATP homeostasis during chronic cold stress and recovery in the chill susceptible beetle (*Alphitobius diaperinus*). *Comparative Biochemistry and Physiology A* 160: 63-67.
- Eliason, E.J., Clark, T.D., Hague, M.J., Hanson, L.M., Gallagher, Z.S., Jeffries, K.M., Gale, M.K., Patterson, D.A., Hinch, S.G. and Farrell, A.P. (2011) Differences in thermal tolerance among sockeye salmon populations. *Science* 332: 109-112.

- Farrell, A.P., Hinch, S.G., Cooke, S.J., Patterson, D.A., Crossin, G.T., Lapointe, M. and Mathes, M.T. (2008) Pacific salmon in hot water: applying aerobic scope models and biotelemetry to predict the success of spawning migrations. *Physiological and Biochemical Zoology* 81: 697-708.
- Feala, J.D., Coquin, L., McCulloch, A.D. and Paternostro, G. (2007). Flexibility in energy metabolism supports hypoxia tolerance in *Drosophila* flight muscle: metabolomic and computational systems analysis. *Molecular Systems Biology* 3: 99.
- Frederich, M. and Pörtner, H.-O. (2000) Oxygen limitation of thermal tolerance defined by cardiac and ventilatory performance in spider crab, *Maja squinado*. *American Journal of Physiology* 279: R1531-R1538.
- Hamada, F.N., Rosenzweig, M., Kang, K., Pulver, S.R., Ghezzi, A., Jegla, T.J. and Garrity, P.A. (2008) An internal thermal sensor controlling temperature preference in *Drosophila*. *Nature* 454: 217-220.
- Harrison, J., Camazine, S., Marden, J.H., Kirkton, S.D., Rozo, A. and Yang, X.L. (2001) Mite not make it home: tracheal mites reduce the safety margin for oxygen delivery of flying honeybees. *The Journal of Experimental Biology* 204: 805-814.
- Hazell, S.P. and Bale, J.S. (2011). Low temperature thresholds: Are chill coma and CT_{min} synonymous? *Journal of Insect Physiology* 57: 1085-1089.
- Hoback, W.W., Podrabsky, J.E., Higley, L.G., Stanley, D.W. and Hand, S.C. (2000) Anoxia tolerance of con-familial tiger beetle larvae is associated with differences in energy flow and anaerobiosis. *Journal of Comparative Physiology B* 170: 307-314.
- Hoback, W.W. and Stanley, D.W. (2001). Insects in hypoxia. *Journal of Insect Physiology* 47: 533-542.
- Hosler, J.S., Burns, J.E. and Esch, H.E. (2000) Flight muscle resting potential and species-specific differences in chill-coma. *Journal of Insect Physiology* 46: 621-627.
- Judge, K.A. (2010). Female social experience affects the shape of sexual selection on males. *Evolutionary Ecology Research* 12: 389-402.
- Klok, C.J. and Chown, S.L. (2003) Resistance to temperature extremes in sub-Antarctic weevils: interspecific variation, population differentiation and acclimation. *Biological Journal of the Linnean Society* 78: 401-414.
- Klok, C.J., Sinclair, B.J. and Chown, S.L. (2004). Upper thermal tolerance and oxygen limitation in terrestrial arthropods. *The Journal of Experimental Biology* 207: 2361-2370.

- Koštál, V. and Tollarová-Borovanská, M. (2009) The 70 kDa heat shock protein assists during the repair of chilling injury in the insect, *Pyrrhocoris apterus*. *PLoS One* 4: e4546.
- Koštál, V., Vambera, J. and Bastl, J. (2004) On the nature of pre-freeze mortality in insects: water balance, ion homeostasis and energy charge in the adults of *Pyrrhocoris apterus*. *The Journal of Experimental Biology* 207: 1509-1521.
- Koštál, V., Yanagimoto, M. and Bastl, J. (2006) Chilling-injury and disturbance of ion homeostasis in the coxal muscle of the tropical cockroach (*Nauphoeta cinerea*). *Comparative Biochemistry and Physiology B* 143: 171-179.
- Kovac, H., Stabentheiner, A., Hetz, S.K., Petz, M. and Crailsheim, K. (2007) Respiration of resting honeybees. *Journal of Insect Physiology* 53: 1250-1261.
- Lannig, G., Bock, C., Sartoris, F.J. and Pörtner, H.-O. (2004) Oxygen limitation of thermal tolerance in cod, *Gadus morhua* L., studied by magnetic resonance imaging and on-line venous oxygen monitoring. *American Journal of Physiology* 287: R902-10.
- Lannig, G., Cherkasov, A.S., Pörtner, H.-O., Bock, C. and Sokolova, I.M. (2008) Cadmium-dependent oxygen limitation affects temperature tolerance in eastern oysters (*Crassostrea virginica* Gmelin). *American Journal of Physiology* 294: R1338-R1346.
- Lighton, J.R.B. and Lovegrove, B.G. (1990) A temperature-induced switch from diffusive to convective ventilation in the honeybee. *The Journal of Experimental Biology* 154: 509-516.
- Lighton, J.R.B. and Turner, R.J. (2004) Thermolimit respirometry: an objective assessment of critical thermal maxima in two sympatric desert harvester ants, *Pogonomyrmex rugosus* and *P. californicus*. *The Journal of Experimental Biology* 207: 1903-1913.
- Lighton, J.R.B., and Schilman, P.E. (2007) Oxygen Reperfusion Damage in an Insect. *PLoS One* 2: e1267.
- MacMillan, H. A., Williams, C. M., Staples, J. F. and Sinclair, B. J. (2012). Metabolism and energy supply below the critical thermal minimum of a chill-susceptible insect. *The Journal of Experimental Biology* 215: 1366–1372.
- Makarieva, A.M., Gorshkov, V.G., Li, B.-L. and Chown, S.L. (2006) Size- and temperature-independence of minimum life-supporting metabolic rates. *Functional Ecology* 20: 83-96.

- Martins, E.G., Hinch, S.G., Patterson, D.A., Hague, M.J., Cooke, S.J., Miller, K.M., Lapointe, M.F., English, K.K. and Farrell, A.P. (2011) Effects of river temperature and climate warming on stock-specific survival of adult migrating Fraser River sockeye salmon (*Oncorhynchus nerka*). *Global Change Biology* 17: 99-114.
- Melzner, F., Mark, F.C. and Pörtner, H.-O. (2007) Role of blood-oxygen transport in thermal tolerance of the cuttlefish, *Sepia officinalis*. *Integrative and Comparative Biology* 47: 645-655.
- Noll, F. (1984) L-lactate. In *Methods of Enzymatic Analysis, 3rd Ed., Vol. VI: Metabolites* (ed. H. U. Bergmeyer), pp. 582-588. Weimheim: Verlag Chemie.
- Nyamukondiwa, C. and Terblanche, J.S. (2010) Within-generation variation of critical thermal limits in adult Mediterranean and Natal fruit flies *Ceratitis capitata* and *Ceratitis rosa*: thermal history affects short-term responses to temperature. *Physiological Entomology* 35: 255-264.
- Overgaard, J., Malmendal, A., Sørensen, J.G., Bundy, J.G., Loeschcke, V., Nielsen, N.C. and Holmstrup, M. (2007). Metabolomic profiling of rapid cold hardening and cold shock in *Drosophila melanogaster*. *Journal of Insect Physiology* 53: 1218-1232.
- Pinheiro, J., Bates, D., DebRoy, S., Sarkar, D. and the R Development Core Team (2011) nlme: linear and non-linear mixed effects models. R package version 3.1-102.
- Pörtner, H.-O. and Knust, R. (2007) Climate change affects marine fishes through the oxygen limitation of thermal tolerance. *Science* 315: 95-97.
- Pörtner, H.-O., Mark, F.C. and Bock, C. (2004) Oxygen limited thermal tolerance in fish? answers obtained by nuclear magnetic resonance techniques. *Respiratory Physiology and Neurobiology* 141: 243-260.
- Pörtner, H.-O. (2010) Oxygen- and capacity-limitation of thermal tolerance: a matrix for integrating climate-related stressor effects in marine ecosystems. *The Journal of Experimental Biology* 213: 881-893.
- R Development Core Team (2011) R: a language and environment for statistical computing.
- Rakshpal, R. (1962) Diapause in the eggs of *Gryllus pennsylvanicus* Burmeister (Orthoptera: Gryllidae). *Canadian Journal of Zoology* 40: 179-194.
- Rodgers, C.I., Armstrong, G.A.B. and Robertson, R.M. (2010) Coma in response to environmental stress in the locust: a model for cortical spreading depression. *Journal of Insect Physiology* 56: 980-990.

- Schröer, M., Wittmann, A.C., Grüner, N., Steeger, H.-U., Bock, C., Paul, R. and Pörtner, H.-O. (2009) Oxygen limited thermal tolerance and performance in the lugworm *Arenicola marina*: a latitudinal comparison. *Journal of Experimental Marine Biology and Ecology* 372: 22-30.
- Sinclair, B.J., Klok, C.J. and Chown, S.L. (2004) Metabolism of the sub-Antarctic caterpillar *Pringleophaga marioni* during cooling, freezing and thawing. *The Journal of Experimental Biology* 207: 1287-1294.
- Staszak, D. and Mutchmor, J.A. (1973) Influence of temperature on induction of chill-coma and movement of american cockroach, *Periplaneta americana*. *Comparative Biochemistry and Physiology A* 45: 895-908.
- Stevens, M.M., Jackson, S., Bester, S.A., Terblanche, J.S. and Chown, S.L. (2010) Oxygen limitation and thermal tolerance in two terrestrial arthropod species. *The Journal of Experimental Biology* 213: 2209-2218.
- Terblanche, J.S., Deere, J.A., Clusella-Trullas, S., Janion, C. and Chown, S.L. (2007) Critical thermal limits depend on methodological context. *Proceedings of the Royal Society B* 274: 2935-2942.
- Terblanche, J.S., Clusella-Trullas, S., Deere, J.A. and Chown, S.L. (2008) Thermal tolerance in a south-east African population of the tsetse fly *Glossina pallidipes* (Diptera, Glossinidae): implications for forecasting climate change impacts. *Journal of Insect Physiology* 54: 114-127.
- Van Dijk, P.L.M., Tesch, C., Hardewig, I. and Pörtner, H.-O. (1999) Physiological disturbances at critically high temperatures: a comparison between stenothermal Antarctic and eurythermal temperate eelpouts (Zoarcidae). *The Journal of Experimental Biology* 202: 3611-3621.
- Verberk, W.C.E.P., Bilton, D.T., Calosi, P. and Spicer, J.I. (2011) Oxygen supply in aquatic ectotherms: partial pressure and solubility together explain biodiversity and size patterns. *Ecology* 92: 1565-1572.
- Williams, C.M., Pelini, S.L., Hellmann, J.J. and Sinclair, B.J. (2010) Intra-individual variation allows an explicit test of the hygric hypothesis for discontinuous gas exchange in insects. *Biology Letters* 6: 274-277.
- Williamson, J.R. (1990) L-alanine determination with alanine aminotransferase. In *Methods of Enzymatic Analysis, 3rd Ed., Vol. VIII: Metabolites III: Lipids, Amino Acids and Related Compounds* (ed. H. U. Bergmeyer), pp. 345-347. Weinheim: Verlag Chemie.
- Zielinski, S. and Pörtner, H.-O. (1996) Energy metabolism and ATP free-energy change of the intertidal worm *Sipunculus nudus* below a critical temperature. *Journal of Comparative Physiology B* 166: 492-500.

Chapter 4

4 The role of the gut in insect chilling-injury: cold-induced disruption of osmoregulation in the fall field cricket, *Gryllus pennsylvanicus*

This chapter was published in similar form in *The Journal of Experimental Biology* (MacMillan and Sinclair, 2011).

4.1 Introduction

The effects of a changing climate on the distribution and abundance of ectotherms will depend on the evolutionary plasticity of physiological mechanisms setting critical thermal limits to activity and fitness (Pörtner et al., 2006; Angilletta, 2009). While the physiological mechanisms setting such limits are increasingly well-known in marine animals, critical thermal limits of terrestrial animals, most notably insects, are very poorly understood. At the critical thermal minimum (CT_{min}), an insect enters chill-coma, where movement ceases entirely (Semper, 1883; Mellanby, 1939). While some temperate and polar insect species survive exposure to extreme cold, most insects are killed at low temperatures by processes unrelated to freezing (Lee, 2010). Such chill-susceptible species enter chill-coma at relatively mild temperatures and die from the accumulation of cellular and whole-animal damage (chilling-injury) during cold-exposure.

When in chill-coma, insect nerves are electrically silent and there is a lack of muscle excitability, the latter resulting from a progressive depolarization of muscle equilibrium potential during cooling (Staszak and Mutchmor, 1973; Goller and Esch, 1990; Hosler et al., 2000). Following prolonged cold exposure, two forms of chilling-injury have been described: direct (cold shock) and indirect. Direct chilling-injury occurs over a period of minutes to hours, and is thought to result from cell membrane phase transitions from the liquid crystalline to the gel phase during rapid cooling (Quinn, 1985; Drobnis et al., 1993). Indirect chilling-injury occurs over a period of days to weeks, and proposed

mechanisms include mismatching of metabolic pathways, oxidative stress and loss of ion homeostasis (Rojas and Leopold, 1996; Yocum, 2001; Košťál et al., 2004; Košťál et al., 2006). Although the physiological nature of chilling-injury is largely unknown, the injury itself can be identified in the animal by a loss of coordination (e.g. impaired gait or inability to right itself when flipped onto its back) or by failure to complete development (Rojas and Leopold, 1996; Košťál et al., 2006; Košťál and Tollarová-Borovanská, 2009).

In insects, ion homeostasis at the organismal level is regulated by the Malpighian tubules and the gut, and varies considerably among species, particularly depending on diet (O'Donnell, 2008). Typically, the Malpighian tubules produce primary urine, that is roughly isosmotic with the hemolymph, by coupling the action of a V-ATPase and H⁺-cation exchangers, ultimately driving K⁺, Cl⁻ (and Na⁺, in blood-feeding insects) movement transcellularly from the hemolymph into the lumen. This process maintains a gradient favoring movement of water (through aquaporins) and waste products (through dedicated transporters) into the lumen of the tubules (Ramsay, 1954; Pannabecker, 1995; O'Donnell, 2009; Spring et al., 2009). While some reabsorption of water and ions occurs along the length of the Malpighian tubule, most water and ion reabsorption in terrestrial insects (specifically locusts) occurs in the hindgut, where Na⁺/K⁺-ATPase and an electrogenic Cl⁻ pump maintain steep local osmotic gradients driving the movement of water and Na⁺ back into the hemolymph (Ramsay, 1971; Hanrahan and Phillips, 1982).

At the cellular level, ion homeostasis is regulated through ion-motive pumps coupled to channels and/or secondary transporters that strictly maintain differences in the intracellular and extracellular concentrations of physiologically-active inorganic ions, particularly Na⁺, K⁺, Mg²⁺, Ca²⁺, and Cl⁻. ATP-dependent ion pumps (e.g. Na⁺/K⁺-ATPase), generate and maintain transmembrane electrochemical gradients that are utilized by secondary active transporters, such as the Na⁺/K⁺/2Cl⁻-transporter, to move ions against their electrochemical gradients. The bulk movement of ions down their electrochemical gradient is facilitated by ion-specific channels that may or may not be gated (Heimlich et al., 2004; Lang et al., 2007), while water movement is facilitated by the presence of aquaporins (Spring et al., 2009).

During exposure to environmental stress, maintenance of ion homeostasis is of great importance; intracellular and extracellular ion abundance largely determine osmotic pressure, and are thus crucial for regulating cellular water balance. When cooled, the activity of ion-motive ATPases would be expected to decline with a Q_{10} between 2 and 3. Conversely, the diffusion of ions down their concentration gradients would be relatively unaffected by temperature (Zachariassen et al., 2004). This would lead to a time- and temperature-dependent loss of ion and water homeostasis at both the cellular and tissue level during cold exposure, provided pathways for such movement (ion channels, aquaporins or paracellular pathways) remain open.

Many important cell functions, including signal transmission in nerve and muscle tissue, rely on coordinated changes in Na^+ , K^+ and Ca^{2+} equilibrium potentials. In addition, alterations to the intracellular abundance of ionic species and their control over intracellular water content are known to play important roles in signaling cascades leading to cellular apoptosis (Mattson and Chan, 2003; Heimlich et al., 2004; Lang et al., 2007). In insects, apoptosis is a known correlate of whole-animal cold-induced injury and rapid plasticity in sensitivity to chilling-injury is associated with reduced levels of apoptosis following cold exposure in *Drosophila melanogaster* (Yi et al., 2007).

Highly cold-tolerant insects, such as freeze-avoiding pine beetles (*Rhagium inquisitor*, Coleoptera: Cerambycidae) are able to maintain ion gradients during prolonged exposure to $-10\text{ }^{\circ}\text{C}$, while freeze-tolerant wood flies (*Xylophagus cinctus*; Diptera: Xylophagidae) permit the redistribution of ions during ice formation in the hemocoel, but maintain osmotic neutrality between intracellular and extracellular compartments, thus avoiding a net movement of water (Dissanayake and Zachariassen, 1980; Kristiansen and Zachariassen, 2001; Zachariassen et al., 2004). Chill-susceptible species, however, appear unable to maintain such control. During progressive cooling, flight muscle resting potential decreases exponentially in both *Drosophila melanogaster* (Diptera: Drosophilidae) and *Apis mellifera* (Hymenoptera: Apidae; Hosler et al., 2000). In chill-susceptible tropical cockroaches (*Nauphoeta cinerea*, Dictyoptera: Blaberidae), muscle equilibrium potentials decline in a manner that correlates with the incidence of chilling-injury. Nearly all changes in ion concentration driving the loss of potential, however,

appear to occur in the hemolymph and not the muscle tissue (Košťál et al., 2006). Such patterns imply interactions between the hemolymph and tissues other than muscle may be driving the loss of muscle equilibrium potentials during cooling. Studies that have addressed the loss of ion balance during cooling have exclusively measured ion concentrations or their effects on muscle potential, and thus overlooked the potential for interactive effects of tissue or hemolymph water content and ion abundance (Goller and Esch, 1990; Hosler et al., 2000; Košťál et al., 2004; Košťál et al., 2006; Košťál et al., 2007).

The purpose of the present study was to determine the roles and potential interactions of the alimentary canal, hemolymph and muscle tissue in the disruption of ion and water balance during chilling in a chill-susceptible insect, the fall field cricket (*Gryllus pennsylvanicus*, Orthoptera: Gryllidae). I hypothesized that diffusion of ions down their concentration gradients between the hemolymph and gut drive a redistribution of water and the subsequent loss of muscle equilibrium potentials and progression of chilling-injury during cold exposure.

4.2 Materials and methods

4.2.1 Animal rearing

A population of *G. pennsylvanicus* derived from individuals collected in 2004 from the University of Toronto Mississauga campus (43.3 °N, 79.4 °W), was laboratory-reared under constant summer conditions (25 °C, 14:10 L:D, 70 % R.H.) following Judge (Judge, 2010). Briefly, crickets were fed commercial rabbit feed (Little Friends Rabbit Food, Martin Mills Inc., Elmira, ON, Canada) and water *ad-libitum*. Adults were given access to 500 mL containers filled with a 4:1 mixture of fine vermiculite and sand for one-week periods to lay eggs. Containers containing eggs were then transferred to a 4 °C cold room for 3 months to accommodate an obligate diapause (Rakshpal, 1962) before being returned to 25 °C conditions to complete development. Gravid adult females, approximately three weeks post final molt were used for all experiments.

4.2.2 Determination of CT_{min} and survival of chronic cold exposure

Critical thermal minima were determined using a method modified from Klok and Chown (1997). Twelve crickets were placed individually into closed 200 mL glass beakers jacketed in a Plexiglas enclosure through which an ethylene glycol:water mix (1:1 v:v) was circulated from a programmable refrigerated bath (Model 1157P, VWR International, Mississauga, ON, Canada). The temperature inside each well was monitored with type-T thermocouples connected to a computer via a Picotech TC-08 thermocouple interface and PicoLog software (Pico Technology, Cambridge, UK). The chambers were cooled linearly from 25 °C at 0.25 °C min⁻¹, allowing for measurement of temperature within each well within 0.1 °C. Crickets were monitored continuously and the CT_{min} was the temperature at which no movement could be elicited from a cricket after harassment from a blunt plastic probe inserted through a small hole in the lid of the beaker.

To assess survival, crickets were placed into individual 14 mL plastic tubes which were loosely covered (to allow air flow), cooled from 25 °C to 0 °C at 0.25 °C min⁻¹ and held at 0 °C (a temperature where all individuals would be in chill-coma) for up to five days (120 h). Every 12 h, a group of 10 crickets was removed and placed at 25 °C in plastic Petri dishes with access to food and water. Survival and chilling-injury were scored 6 and 24 h after removal from cold conditions. Crickets were coaxed to run across a flat bench surface and perform a jump. Crickets that moved in a coordinated manner and performed a jump were scored as fit. Crickets that lacked coordination (encompassing a broad range of severity) or could not jump were scored as chill-injured. Individuals that showed no signs of movement were scored as dead (Košťál et al., 2006).

4.2.3 Tissue sampling

To quantify ion and water content of muscle, hemolymph and gut, crickets were cooled from 25 to 0 °C at 0.25 °C min⁻¹, and held at 0 °C as above. One set of crickets was used to obtain samples of muscle and hemolymph and a second set was used to obtain samples of the gut.

Control crickets were anaesthetised lightly with CO₂ and dissected at 22 °C, while cold-exposed crickets remained in chill-coma and were dissected in a 4 °C cold room (~3 min per dissection). A small incision was made at the base of each hind leg and hemolymph was collected using a micropipette. The thorax and abdomen were then opened and any additional hemolymph was collected in the same manner. The volume of hemolymph collected was used to approximate total hemolymph volume. I did not quantify hemolymph volume using the radiolabeled inulin dilution technique (Loughton and Tobe, 1969) because it requires the heart to actively mix the hemolymph (Samaranayaka, 1977), and insect hearts do not beat in chill-coma. Muscle tissue was collected from a single hind femur of each animal using forceps and was blotted lightly on a KimWipe to remove any hemolymph remaining on the tissue. All tissue samples were placed into pre-weighed 200 µL PCR tubes.

The foregut (crop and proventriculus), midgut and hindgut were isolated by removing the legs and wings and making a dorsal longitudinal incision from the tip of the abdomen to the base of the head. Junctions between the proventriculus, midgut and hindgut were ligated and dissected out, starting with the hindgut and proceeding forward. This process ensured no mixing of gut contents occurred between sections during the dissection process, and that no gut contents were lost during isolation. Tracheae, Malpighian tubules and fat body surrounding the gut were gently removed and discarded. Gut sections were blotted lightly on a KimWipe to remove residual hemolymph, the ligatures were removed, and the gut sections placed into pre-weighed 200 µL PCR tubes.

4.2.4 Sample preparation and analysis

Tissue samples were weighed to obtain wet mass, dried (with the tube lids open) in an oven at 70 °C for 48 h, and reweighed to determine dry mass. Nitric acid (200 µL) was added to the dried tissue in each tube and samples were kept at 22 °C for 24 h with occasional mixing until the tissue was completely dissolved. Samples were diluted with double-distilled H₂O to bring them within measurable range of the atomic absorption spectrometer (iCE 3300, Thermo Scientific, Waltham MA, USA) and absorption compared to standard curves of Na⁺, K⁺, Mg²⁺ and Ca²⁺ generated from diluted standards containing nitric acid.

4.2.5 Data analysis

Muscle cell membrane equilibrium potentials for each ion were calculated for each cricket sampled using the Nernst equation:

$$E = \left(\frac{RT}{zF}\right) \cdot \ln \frac{[Extracellular]}{[Intracellular]} \quad (1)$$

Where R is the universal gas constant, T is the absolute temperature, z is the ionic charge, F is Faraday's constant, $[Extracellular]$ is the ion concentration in the hemolymph, and $[Intracellular]$ is the ion concentration in the muscle tissue.

Statistical analyses were conducted using SAS 9.2 (SAS Institute Inc., Cary, NC, USA). Ion and water content data from control (no cold exposure) crickets and those exposed to 0 °C for the shortest duration (6 or 12 h) were compared using t-tests, and table-wide p-values adjusted with false discovery rate (FDR) correction using the PROC MULTTEST function. Use of FDR in this manner controls for increased likelihood of type 1 error when making multiple comparisons (Benjamini and Hochberg, 1995). This approach was taken because clear differences were observed in the direction and rate of change of ion and water content between the first 6 or 12 h of cold exposure and prolonged cold exposure. If there was a significant difference between control crickets and those that experienced the shortest duration of cold exposure, implying a rapid cold-induced change, control crickets were excluded from the regression analysis. Ion and water content data of both raw and natural log-transformed data were then analyzed using the PROC GLM function and the model with the highest R^2 value was used within each data set. Tissue dry mass was used as a covariate to account for sample mass as appropriate. As the effect of dry mass on ion and water content was always significant ($P < 0.001$), only the effects of exposure time are reported in such cases. Degrees of freedom, values of statistics and precise P -values are presented in Appendix A (Tables A.1-A.3), and only the level of significance is reported within the body of this chapter. All values reported for descriptive purposes are sample means \pm sem.

4.3 Results

4.3.1 CT_{min} and survival at 0 °C

When cooled at 0.25 °C min^{-1} , female crickets entered chill-coma at $2.3 \pm 0.1\text{ °C}$. All crickets exposed to 0 °C were in chill-coma when removed to room temperature for survival analysis. When assessed following 6 h of recovery at 25 °C , chilling-injury was noted after as little as 12h at 0 °C , and 60 % of crickets were injured following 60 h (3 days) of exposure (Figure 4.1A). Following 120 h (5 days) at 0 °C and 24 h of recovery time, all of the crickets were dead (Figure 4.1B). Individuals from several time points scored as injured 6 h after warming were dead 24 h following warming, while one individual (of 10 crickets cold-exposed for 48 h) scored after 6 h as injured was later scored as fit (Figure 4.1A,B).

4.3.2 Hemolymph and muscle ion concentrations

Hemolymph $[Na^+]$ declined from $189.4 \pm 19.7\text{ mM}$ to $127.0 \pm 5.4\text{ mM}$ during the first 12 h at 0 °C ($P < 0.05$), then continued to drop linearly ($P < 0.001$), but at a slower rate during continued cold exposure (Figure 4.2A). By contrast, hemolymph $[K^+]$ increased significantly from $7.0 \pm 0.9\text{ mM}$ to $14.7 \pm 1.7\text{ mM}$ in the first 12 h at 0 °C ($P < 0.01$), and continued to increase to $41.9 \pm 3.9\text{ mM}$ following 120 h at 0 °C ($P < 0.001$; Figure 4.2B). Hemolymph $[Mg^{2+}]$ significantly declined in the first 12 h, ($P < 0.05$), however, there was no further effect of prolonged cold exposure and mean $[Mg^{2+}]$ returned to control levels at several time points throughout cold exposure ($P > 0.05$; Figure 4.2C).

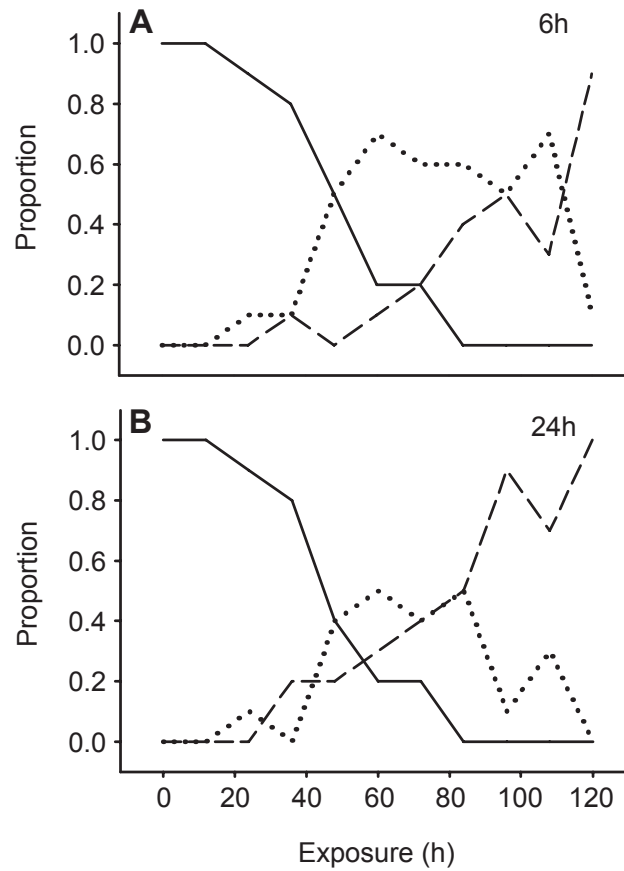

Figure 4.1. Survival of *G. pennsylvanicus* 6 h (A) and 24 h (B) following removal from exposure to 0 °C for up to 120 h. Survival data are presented as a proportion of fit (solid line) injured (dotted line) and dead (dashed line) individuals. Fit crickets were defined as able to move in a coordinated manner and perform a jump. Injured crickets were defined by a lack of coordination or inability to jump. Dead crickets did not move at all. $n=10$ crickets per 12 h period.

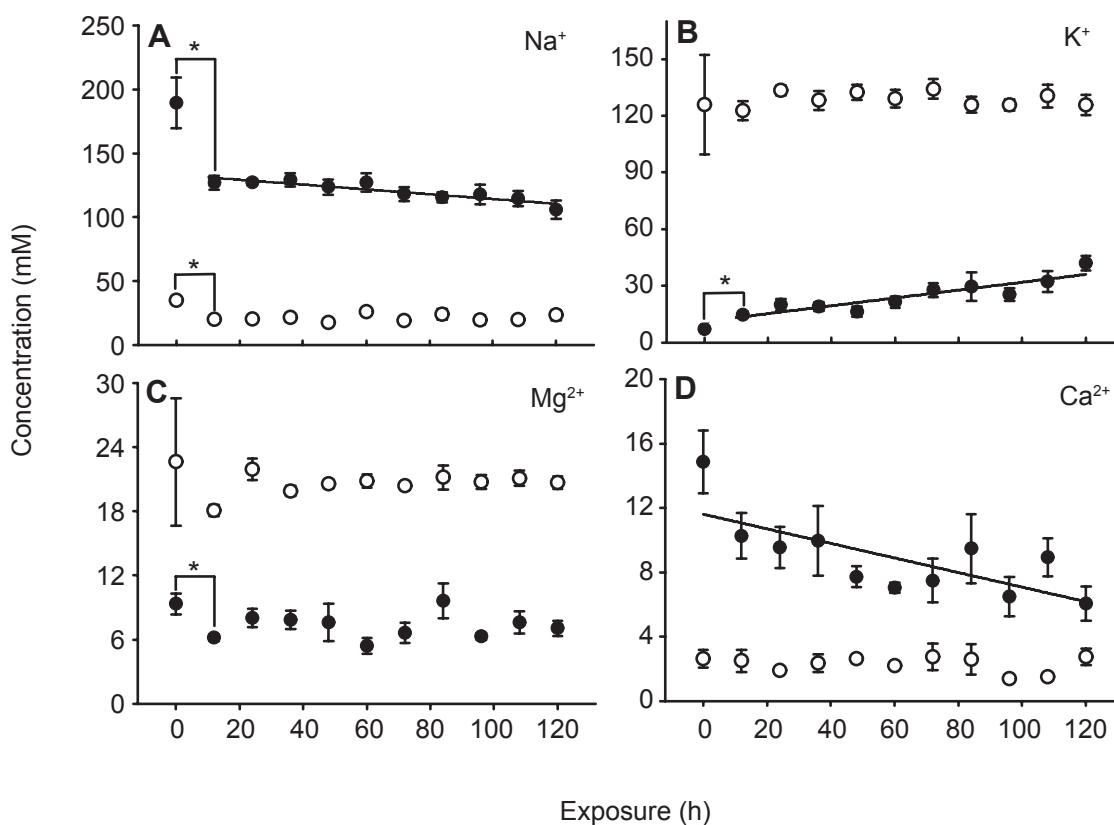

Figure 4.2. Concentration (mean \pm sem) of Na⁺ (A), K⁺ (B), Mg²⁺ (C) and Ca²⁺ (D) in hemolymph (filled) and femur muscle tissue (open) of *G. pennsylvanicus* during exposure to 0 °C for up to 120 h. Asterisks denote significant changes in ion concentration within the first 12 h (see results), and lines denote significant linear relationships between time at 0 °C and ion concentration. $n=6$ crickets per 12 h period. Error bars that are not visible are obscured by the symbols.

Hemolymph $[Ca^{2+}]$ did not significantly decline in the first 12 h of cold exposure ($P>0.05$), but declined significantly from 14.9 ± 1.9 mM to 6.1 ± 1.1 mM during prolonged cold exposure ($P<0.001$; Figure 4.2D). In the muscle tissue, $[Na^+]$ declined significantly from 35.0 ± 2.8 mM to 20.3 ± 1.9 mM in the first 12 h of cold exposure ($P<0.01$), though there was no continued effect of exposure duration ($P>0.05$; Figure 4.2A). Cold exposure did not significantly alter muscle $[K^+]$, $[Mg^{2+}]$ or $[Ca^{2+}]$ in the first 12 h of cold exposure, nor did prolonged cold exposure affect concentrations of these ions ($P>0.05$; Figure 4.2B,C,D).

No significant changes in Na^+ , K^+ , Mg^{2+} or Ca^{2+} muscle equilibrium potentials (E_{Na} , E_K , E_{Mg} , E_{Ca} , respectively) were observed in the first 12 h of cold exposure ($P>0.05$). However, E_K significantly depolarized from -71.7 ± 3.3 mV to -29.4 ± 2.7 mV following exposure to $0^\circ C$ for 120 h ($P<0.001$; Figure 4.3). Similarly, E_{Ca} significantly declined from 23.4 ± 1.6 mV under control conditions to 11.4 ± 2.32 mV following 120 h at $0^\circ C$ ($P<0.05$). E_{Na} and E_{Mg} did not significantly change during cold exposure ($P>0.05$; Figure 4.3).

4.3.3 Tissue water content

Muscle water content did not significantly change during the first 12 h of cold exposure, nor over the duration of cold exposure ($P>0.05$; Figure 4.4A). Hemolymph volume significantly decreased in an exponential manner from an initial mean volume of 40.8 ± 2.6 μL to 6.4 ± 2.1 μL in crickets exposed to 72 h or longer at $0^\circ C$ ($P<0.001$; Figure 4.4B). Over the same time period, total gut water content increased from an initial mean volume of 66.2 ± 6.7 μL to 95.7 ± 13.5 μL in crickets exposed to $0^\circ C$ for 72 h or longer ($P<0.05$; Figure 4.4B). The decrease in hemolymph volume and increase in total gut volume in the first 6 h of cold exposure were not statistically significant ($P>0.05$). Following 120 h at $0^\circ C$, crickets significantly lost 16.10 ± 1.73 mg (c. 3 %) of their body mass ($P<0.001$).

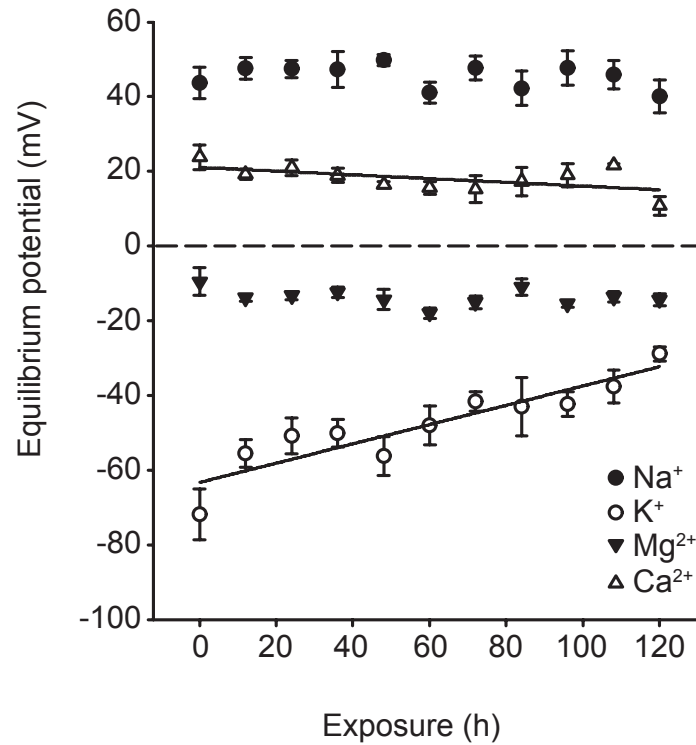

Figure 4.3. Calculated equilibrium potentials (mean \pm sem) of Na⁺ (filled circles), K⁺ (open circles), Mg²⁺ (filled triangles) and Ca²⁺ (open triangles) of muscle cell membranes of *G. pennsylvanicus* during prolonged exposure to 0 °C. No significant changes in equilibrium potentials in the first 12 h were found. Lines denote significant linear relationships between cold exposure duration and equilibrium potentials. $n=6$ crickets per 12 h period. Error bars that are not visible are obstructed by the symbols.

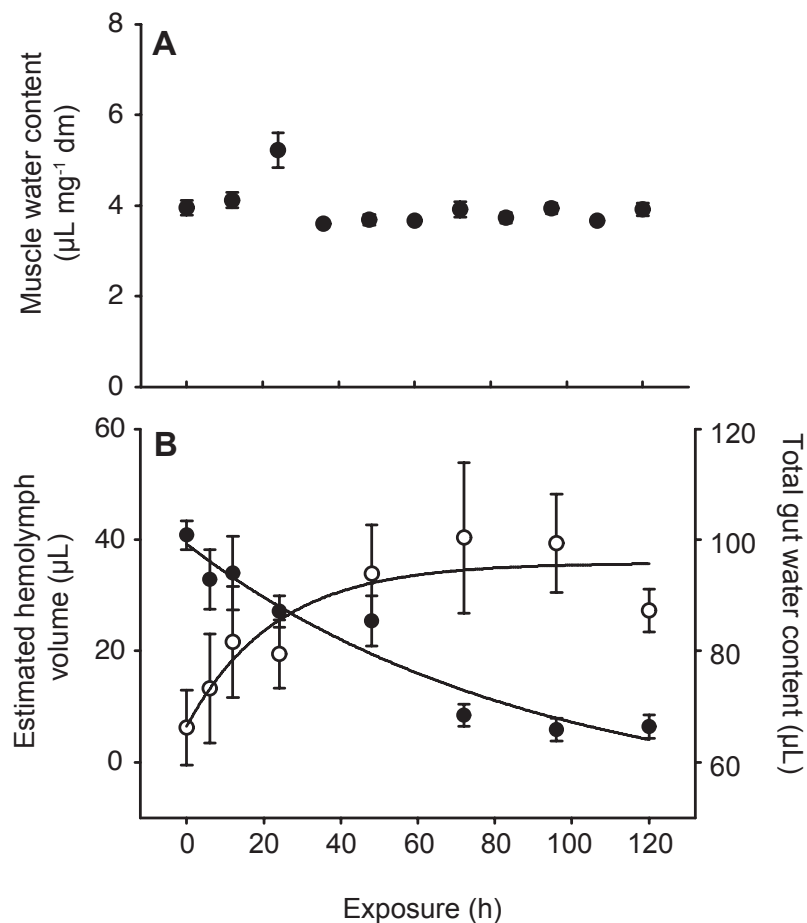

Figure 4.4. Mean \pm sem muscle water content (A; expressed as μL per mg of muscle dry mass) and hemolymph volume (filled circles) and total gut water content (open circles) (B) of *G. pennsylvanicus* during exposure to $0\text{ }^{\circ}\text{C}$ for up to 120 h. Cold exposure did not significantly affect muscle water content. Hemolymph water content and total gut water content fell and rose, respectively, in an exponential manner that was statistically significant (see text for statistics). Total water accumulation in the gut accounts for c. 86 % of lost hemolymph volume. $n=6$ and 8 crickets per sampling period for muscle water content and hemolymph and gut analysis, respectively. Error bars that are not visible are obscured by the symbols.

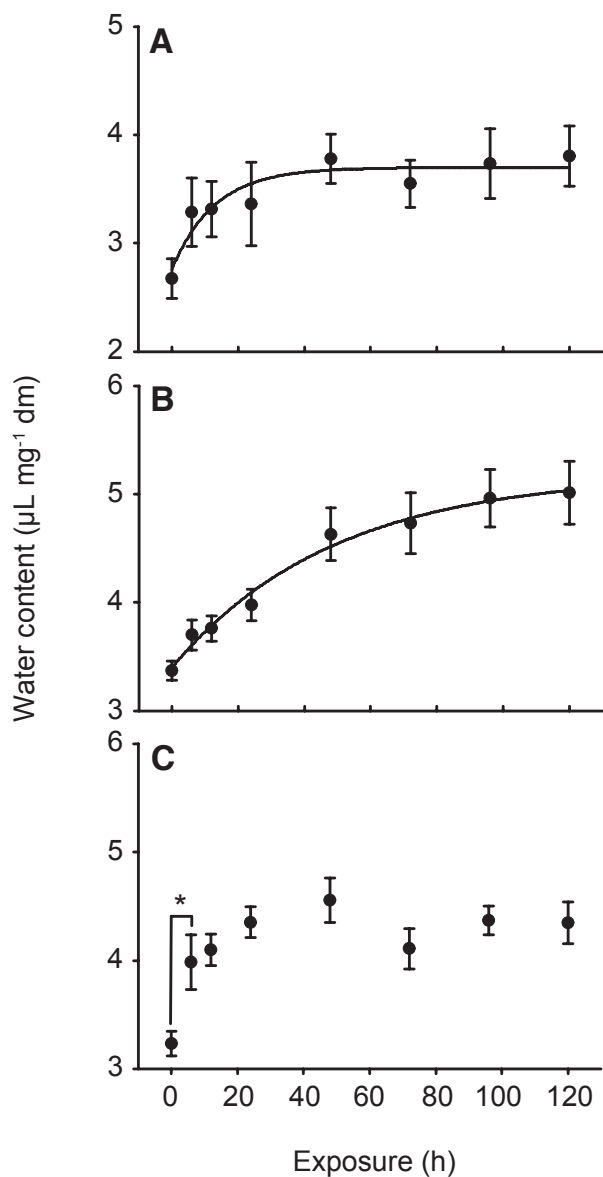

Figure 4.5. Mean (\pm sem) foregut (A), midgut (B), and hindgut (C) water content (expressed as μL per mg tissue dry mass) of *G. pennsylvanicus* exposed to 0 °C for up to 120 h. Exposure to 0 °C caused a significant accumulation of water in all regions of the gut. Asterisks denote significant effects of initial cold exposure and lines of best fit denote a significant relationship between water content and time at 0 °C (see text for statistics). $n=8$ crickets per sampling period.

Water content of the foregut and midgut tended to increase following 6 h of cold exposure, although these increases were marginally non-significant ($P=0.070$ and $P=0.051$, respectively). Total cold exposure duration, however, caused a significant exponential rise in both foregut ($P<0.05$) and midgut ($P<0.001$) water content (Figure 4.5A,B). Foregut water content rose from an initial relative volume of $2.67 \pm 0.18 \mu\text{L mg}^{-1}$ to $3.80 \pm 0.28 \mu\text{L mg}^{-1}$ following 120 h at 0°C , while midgut water content increased from $3.37 \pm 0.09 \mu\text{L mg}^{-1}$ to $5.01 \pm 0.29 \mu\text{L mg}^{-1}$ within the same time period. Cold exposure significantly increased hindgut volume from 3.23 ± 0.12 to $3.98 \pm 0.25 \mu\text{L mg}^{-1}$ within the first 6 h of exposure ($P<0.01$; Figure 4.5C). Following this initial increase, hindgut water content remained high with increased cold exposure duration ($P>0.05$; Figure 4.5C).

4.3.4 Hemolymph and gut ion content

Total hemolymph Na^+ , Mg^{2+} and Ca^{2+} declined exponentially with increasing duration of exposure to 0°C ($P<0.001$; Figure 4.6A,C,D), in contrast with total hemolymph K^+ which did not significantly change ($P>0.05$; Figure 4.6B). Changes in hemolymph Na^+ ($P=0.068$), K^+ ($P=0.085$), Mg^{2+} ($P=0.068$), and Ca^{2+} ($P=0.085$) over the first 12 h were all marginally non-significant, with K^+ tending to increase in the hemolymph while all other ions tended to decrease (Figure 4.6). The total decrease in hemolymph ion content was approximately 87 %, 81 % and 90 % for Na^+ , Mg^{2+} and Ca^{2+} , respectively.

Cold exposure significantly increased foregut Na^+ ($P<0.01$), but this effect was not significant within the first 6 h ($P>0.05$; Figure 4.7A). Exposure to 0°C caused a significant rise in midgut Na^+ in the first 6 h ($P<0.01$), which continued in an exponential manner with prolonged cold exposure ($P<0.05$, Figure 4.7B). In the hindgut, Na^+ increased significantly from $0.23 \pm 0.02 \mu\text{mol mg}^{-1}$ to $0.45 \pm 0.03 \mu\text{mol mg}^{-1}$ in the first 6 h of cold exposure ($P=0.001$), however, this increase was followed by an exponential decrease in hindgut Na^+ between 6 and 120 h at 0°C , during which Na^+ levels in the hindgut fell to $0.29 \pm 0.03 \mu\text{mol mg}^{-1}$ ($P<0.001$; Figure 4.7C).

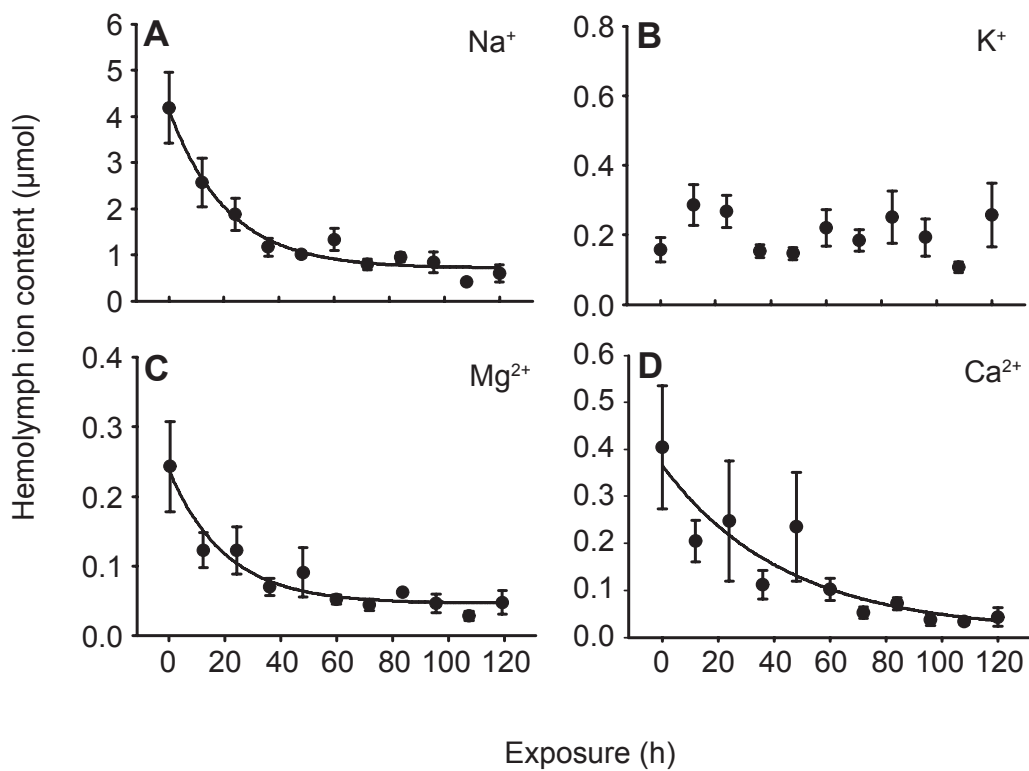

Figure 4.6. Mean (\pm sem) total Na⁺ (A), K⁺ (B), Mg²⁺ (C), and Ca²⁺ (D) content of the hemolymph of *G. pennsylvanicus* during exposure to 0 °C for up to 120 h. Na⁺, Mg²⁺ and Ca²⁺ significantly declined during cold exposure (as indicated by lines of best fit), while there was no significant effect of cold exposure on total hemolymph K⁺ (see text for statistics). $n=6$ crickets per sampling period. Error bars that are not visible are obstructed by the symbols.

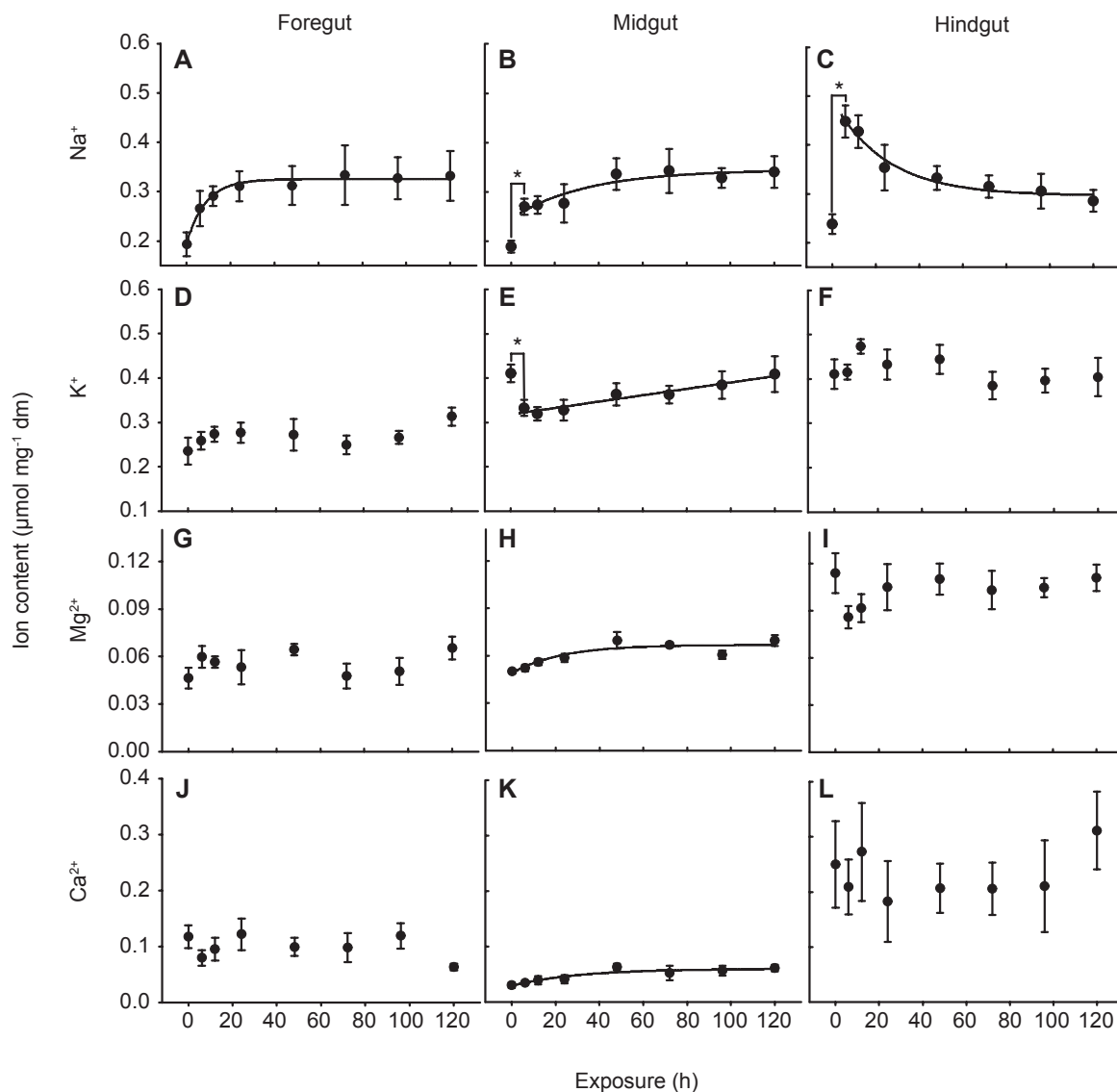

Figure 4.7. Mean (\pm sem) Na⁺ (A-C), K⁺ (D-F), Mg²⁺ (G-I), and Ca²⁺ (J-L) of the foregut (left) midgut (centre) and hindgut (right) of *G. pennsylvanicus* during exposure to 0 °C for 120 h. Significant changes in ion content (expressed as μmol per mg of dry mass, dm) within the first 6 h of cold exposure are denoted with a star. Significant effects of cold exposure duration on ion content are denoted with a line (see text for statistics). Error bars that are not visible are obscured by the symbols.

Foregut K^+ did not significantly change in the first 6 h of cold exposure, or with increased cold exposure duration ($P>0.05$; Figure 4.7D). In the midgut, K^+ significantly declined in the first 6 h, then increased during prolonged cold exposure in a linear manner ($P<0.05$; Figure 4.7E). Hindgut K^+ did not significantly change, either during the first 6 h, or over the entire duration of cold exposure ($P>0.05$; Figure 4.7F).

Cold exposure did not significantly affect foregut or hindgut Mg^{2+} , either in the first 6 h, or over the entire duration of cold exposure ($P>0.05$; Figure 4.7G,I). Midgut Mg^{2+} increased significantly in an exponential manner over the duration of cold exposure ($P<0.001$), though this increase was not significant within the first 6 h ($P>0.05$; Figure 4.7H).

In a similar manner to Mg^{2+} , Ca^{2+} content did not significantly change in the foregut or hindgut, in either the first 6 h, or over the entire duration of cold exposure ($P>0.05$; Figure 4.7J,L). Midgut Ca^{2+} , however, increased significantly in an exponential manner over the duration of cold exposure ($P<0.001$), though this increase was not significant within the first 6 h ($P>0.05$; Figure 4.7K).

4.3.5 Hemolymph color

Of 40 crickets exposed to 48 h of cold exposure or longer, six (15 %) had black hemolymph at the time of dissection. Those individuals with black hemolymph had significantly higher hemolymph volume ($8.79 \pm 2.29 \mu\text{L}$) than the remainder, which had pale yellow hemolymph ($2.78 \pm 0.56 \mu\text{L}$; $t_{36}=3.90$, $P<0.001$). Individuals with black hemolymph also had significantly lower midgut water content ($13.76 \pm 1.82 \mu\text{L}$) than individuals with yellow (normal) hemolymph ($33.70 \pm 1.88 \mu\text{L}$; $t_{36}=5.12$, $P<0.001$).

4.4 Discussion

Exposure of *Gryllus pennsylvanicus* to 0°C caused a redistribution of water between the hemolymph and the gut. The volume of extractable hemolymph declined by approximately 84 % of its initial volume in crickets that were injured and killed by

exposure to 0 °C. This loss of water from the hemolymph over time occurred in an exponential manner that strongly correlated with an increase in water in the gut. A mean of 34 μL was lost from the hemolymph, while approximately 24 μL of water was gained in the gut during cold exposure. The remaining c. 10 μL of water from the hemolymph was likely lost from the body through desiccation during cold exposure, which would account for the majority of the 16 mg decrease in body mass over 120 h at 0 °C I observed.

4.4.1 Osmotic balance of the hemolymph and muscle

In the hemolymph, $[\text{Na}^+]$ and $[\text{Ca}^{2+}]$ both declined while $[\text{K}^+]$ increased and $[\text{Mg}^{2+}]$ remained unchanged with time spent at 0 °C. Within the first 12 h of cold exposure, hemolymph $[\text{Na}^+]$ declined by 62 mM. However, this rapid drop in hemolymph $[\text{Na}^+]$ had little effect on E_{Na} of the muscle, as muscle $[\text{Na}^+]$ declined by a similar proportion at the same time. Surprisingly, despite all of the interactions occurring between the hemolymph and gut during cold exposure, muscle water and ion content otherwise appear to be unchanged, as no other effects of cold exposure were found on the muscle tissue. This reduction in muscle $[\text{Na}^+]$ may be a protective response of temperate insects, and act to prevent muscle E_{Na} from declining while large amounts of Na^+ were being lost from the hemolymph. Overall, cold exposure did not significantly affect muscle E_{Na} in *G. pennsylvanicus*, in contrast to tropical cockroaches, in which E_{Na} declines with duration of cold exposure (Košťál et al., 2006).

Hemolymph Na^+ , Mg^{2+} , and Ca^{2+} contents all decreased in an exponential manner with increased cold exposure duration. Ultimately, the magnitude of loss of Na^+ and Ca^{2+} from the hemolymph was larger than the loss of volume, such that hemolymph concentrations of both ions decreased. While some changes in hemolymph ion concentration reflect the direction of ion movement into or out of the hemolymph, alterations in hemolymph volume can strongly affect interpretations of net ion movement. For example, although Mg^{2+} content decreased overall, the concomitant loss of volume resulted in hemolymph $[\text{Mg}^{2+}]$ remaining stable during cold exposure. Similarly, while $[\text{K}^+]$ increased with time spent at 0 °C, no significant change in total hemolymph K^+ occurred. Thus, the increase

in hemolymph $[K^+]$, and absolute decrease in E_K at the muscle were driven by the decrease in hemolymph volume, and not by an increase in the amount of extracellular K^+ .

Cooling had the largest effect on muscle E_K and E_{Ca} , which declined by 43 mV and 12 mV, respectively. The absolute decline observed in E_K would be sufficient to dissipate muscle membrane potential, as membrane potential closely follows E_K in non-lepidopteran insects (Hoyle, 1953; Wood, 1957; Leech, 1986). In addition, the re-polarizing current of action potentials at the insect muscle membrane is generated by an outward K^+ current, but unlike vertebrates, the rising phase is not generated by the movement of Na^+ , but by an inward Ca^{2+} current that is highly dependent on hemolymph calcium concentration (Hoyle, 1953; Patlak, 1976; Ashcroft, 1981; Collet and Belzunces, 2007). Thus the rise in $[K^+]$ and fall in $[Ca^{2+}]$ in the hemolymph can together explain the drop in resting potential and loss of excitability of insect muscle tissue that likely plays a role in both chill-coma onset and the progression of chilling-injury (Esch, 1988; Hosler et al., 2000; Košťál et al., 2006).

In the insect nervous system, the brain, ventral ganglia and large isolated nerves are all protected from direct exchange of solutes with the hemolymph by the blood-brain barrier, which maintains ion concentrations in the neuronal microenvironment that are very different from those of the hemolymph (Treherne and Schofield, 1979). Because of the blood-brain barrier, whole tissue estimates of ion abundance in the nervous system, such as I present for other tissues, are not sufficient to measure osmotic phenomena of the nervous system, and direct measurements with microelectrodes are required. The nervous system may be important in chill-coma and chilling-injury; in semi-intact preparations of locusts (*Locusta migratoria*; Orthoptera, Acrididae), gradual chilling is associated with a rise in extracellular $[K^+]$ in the nervous system that sometimes coincides with physical arrest (Rodgers et al., 2010). The initial disruption of neuronal and gut osmotic balance during chilling may occur by similar effects of temperature on enzymes responsible for the maintenance of ion balance. In addition, ion balance within the nervous system is ultimately achieved through interaction with the hemolymph, thus both rapid and long-term changes in hemolymph $[Na^+]$, $[K^+]$ and $[Ca^{2+}]$ during cold exposure noted here may potentiate local effects within the nervous system.

4.4.2 Osmotic balance of the alimentary canal

Both water and cations primarily moved from the hemolymph into the gut during cold exposure. The rate of accumulation of water in each of the gut segments closely followed the accumulation of Na^+ in the same segment, although the different patterns in the gut sections suggest that little mixing of gut contents between sections occurs during cold exposure. Phytophagous insects, including locusts and mantids (and therefore probably crickets), tend to have lower levels of Na^+ in the crop than in the hemolymph, owing to the low Na^+ content of plants (Dow, 1981; Hatle et al., 2002). In the foregut, no significant changes in the amount of K^+ , Mg^{2+} or Ca^{2+} were found. This is consistent with the role of the foregut as a solute-impermeable storage area. Foregut Na^+ , however, was low under control conditions and increased exponentially, reaching a plateau following roughly 24 h of cold exposure, implying that Na^+ migrated into the foregut during chilling and that foregut Na^+ is actively regulated under control conditions.

Na^+ was the only ion in the hindgut that changed in abundance with cooling, increasing rapidly in the first 6h, followed by a relatively slower exponential decline. The hindgut contains feces with a low water content driven by local cycling of ions (Na^+ , K^+ , and Cl^-) that drive absorption of water from the hindgut against the prevailing osmotic gradient (Phillips, 1964; Goh and Phillips, 1978; Phillips et al., 1982). Thus, the rectal lumen possesses both high water permeability and a large osmotic gradient that together explain the rapid movement of both water and Na^+ into the hindgut lumen during cold exposure. Exposure to $-5\text{ }^\circ\text{C}$ for up to 60 days caused not only an accumulation of Na^+ and water, but also K^+ in the hindgut of cold-tolerant adult firebugs (*Pyrrhocoris apterus*, Hemiptera: Pyrrhocoridae; Košťál et al., 2004). Thus, accumulation of ions and water in the hindgut also occurs in cold-hardy insects. By allowing K^+ to accumulate in the gut system along with Na^+ , however, cold-hardy insects may protect hemolymph $[\text{K}^+]$ and avoid the effects of K^+ accumulation on survival at relatively mild low temperatures.

The midgut was most sensitive to low temperature exposure, as the concentration of all four ions significantly changed with time spent at $0\text{ }^\circ\text{C}$. Ca^{2+} , Mg^{2+} and Na^+ levels all increased exponentially in the midgut with exposure to $0\text{ }^\circ\text{C}$. The influx of both Na^+ and Ca^{2+} into the midgut appears to coincide with their loss from the hemolymph. However,

although a total of $0.37 \pm 0.11 \mu\text{mol}$ of Ca^{2+} was lost from the hemolymph after 120 h at 0°C , only $0.17 \pm 0.10 \mu\text{mol}$ of this is accounted for by influx into the midgut, implying some Ca^{2+} may have migrated elsewhere in the body. While Mg^{2+} moved into the midgut during cold exposure, its concentration in the hemolymph was unaffected, suggesting that Mg^{2+} was driven into the midgut during cold exposure by the potential produced by the reduction of hemolymph volume, and likely remained in equilibrium between the hemolymph and midgut. Midgut K^+ content significantly decreased in the first 6 h and then increased linearly for the remainder of the cold exposure. In larval Lepidoptera, a V-ATPase and K^+ - 2H^+ -antiport combination is utilized to actively transport K^+ from the hemolymph to the midgut (Chamberlin, 1990; Wiczorek et al., 1991; Klein et al., 1996). Although to our knowledge such a mechanism has not been described in Orthoptera, if K^+ is actively transported out of the midgut of *G. pennsylvanicus*, it could explain the initial drop in K^+ in the midgut during exposure to 0°C . As hemolymph volume decreased with continued cold exposure, however, hemolymph $[\text{K}^+]$ likely surpassed the midgut $[\text{K}^+]$, driving an efflux of K^+ from the hemolymph to the midgut. The combined increases in midgut Na^+ , Mg^{2+} and Ca^{2+} , along with the drift of K^+ toward initial levels, likely increased osmotic pressure in the midgut during cold exposure, subsequently driving the influx of water. The midgut is likely to be the most sensitive region of the gut to physical damage from water accumulation; while the foregut and hindgut are derived from ectoderm, and thus have a cuticular lining to provide structural support, the midgut does not (Dow, 1986).

After 48 h or more at 0°C , several crickets had black hemolymph. Darkening of the hemolymph is caused by activity of phenoloxidase, which causes a melanization of the hemolymph that is important in both wound healing and the encapsulation of invading organisms in the hemocoel (Gillespie et al., 1997; Hoffmann et al., 1999). The inactive form of phenoloxidase (prophenoloxidase) which becomes activated during pathogen invasion, has been isolated and characterized in a number of invertebrate species, including an orthopteran (Cherqui et al., 1996), and can be activated at temperatures as low as 0°C (Evans, 1967). In our study, individuals that had dark hemolymph also had significantly reduced midgut volume and significantly increased hemolymph volume compared to crickets with yellow hemolymph. The hemolymph was also thicker and

more difficult to extract from the hemocoel in crickets with black hemolymph. Thus, I postulate that increasing volume of the midgut during cold exposure ruptured the midgut in some crickets, spilling its contents into the hemocoel. Melanization in response to foreign material from the gut would then darken the hemolymph. Such physical damage to the gut is probably not the primary cause of chilling-injury, as only 6 out of 40 crickets had darkened hemolymph, despite 100 % mortality from 120 h at 0 °C.

The observed patterns of water and ion accumulation in the gut imply that gut-hemolymph interactions may play a major role in indirect chilling-injury of chill-susceptible insects. In contrast to chill-susceptible species, highly cold tolerant insects that survive supercooling of their body fluids are known to cease feeding and void or eliminate their gut in preparation for winter (Lee et al., 1996). This strategy acts to remove factors that promote ice formation at low temperatures. However, I suggest that highly cold tolerant insects may also avoid detrimental alterations in hemolymph ion and water content through removal of the gut or its contents.

4.4.3 Conclusion

Exposure to 0°C caused migration of the majority of hemolymph Na^+ , Mg^{2+} , Ca^{2+} and water into the alimentary canal of a chill-susceptible insect. These patterns of ion and water movement caused hemolymph $[\text{Na}^+]$ and $[\text{Ca}^{2+}]$ to decrease and hemolymph $[\text{K}^+]$ to increase, driving absolute decreases in the amplitudes of E_K and E_{Ca} at the muscle tissue. The observed changes in hemolymph ions and water content are likely to affect tissue viability following removal from the cold, and be closely linked with symptoms of indirect chilling-injury. Future directions for understanding the mechanisms of chilling-injury may include investigating the biochemical mechanisms regulating ion and water movement between compartments during cold exposure, and the means by which insects modulate their cold tolerance through changes in gut permeability to ions and water.

4.5 Literature cited

- Angilletta, M.J. (2009) *Thermal adaptation: a theoretical and empirical synthesis*. Oxford: Oxford University Press.
- Ashcroft, F.M. (1981). Calcium action potentials in the skeletal muscle fibres of the stick insect *Carausius morosus*. *The Journal of Experimental Biology* 93: 257-267.
- Benjamini, Y. and Hochberg, Y. (1995). Controlling the false discovery rate: a practical and powerful approach to multiple testing. *Journal of the Royal Statistical Society B* 57: 289-300.
- Chamberlin, M.E. (1990) Ion transport across the midgut of the tobacco hornworm (*Manduca sexta*). *The Journal of Experimental Biology* 150: 425-442.
- Cherqui, A., Duvic, B. and Brehélin, M. (1996) Purification and characterization of prophenoloxidase from the haemolymph of *Locusta migratoria*. *Archives of Insect Biochemistry and Physiology* 32: 225-235.
- Collet, C. and Belzunces, L. (2007) Excitable properties of adult skeletal muscle fibres from the honeybee *Apis mellifera*. *The Journal of Experimental Biology* 210: 454-464.
- Dissanayake, P. and Zachariassen, K.E. (1980) Effect of warm acclimation on the cationic concentrations in the extracellular and intracellular body-fluid of hibernating *Rhagium inquisitor* beetles. *Comparative Biochemistry and Physiology A* 65: 347-350.
- Dow, J.A.T. (1981). Ion and water transport in locust alimentary canal: evidence from *in vivo* electrochemical gradients. *The Journal of Experimental Biology* 93: 167-179.
- Dow, J.A.T. (1986) Insect midgut function. In *Advances in Insect Physiology V.19* (ed. P. D. Evans and V. B. Wigglesworth), pp. 187-328. London: Academic Press.
- Drobnis, E.Z., Crowe, L.M., Berger, T., Anchordoguy, T.J., Overstreet, J.W. and Crowe, J.H. (1993) Cold shock damage is due to lipid phase transitions in cell membranes: a demonstration using sperm as a model. *Journal of Experimental Zoology* 265: 432-437.
- Esch, H.E. (1988). The effects of temperature on flight-muscle potentials in honeybees and cuculiinid winter moths. *The Journal of Experimental Biology* 135: 109-117.
- Evans, J.J.T. (1967) The activation of prophenoloxidase during melanization of the pupal blood of the Chinese oak silkmoth, *Antheraea pernyi*. *Journal of Insect Physiology* 13: 1699-1711.
- Gillespie, J.P., Kanost, M.R. and Trenczek, T. (1997) Biological mediators of insect immunity. *Annual Review of Entomology* 42: 611-643.

- Goh, S. and Phillips, J.E. (1978) Dependence of prolonged water absorption by *in vitro* locust rectum on ion transport. *The Journal of Experimental Biology* 72: 25-41.
- Goller, F. and Esch, H.E. (1990) Comparative study of chill-coma temperatures and muscle potentials in insect flight muscles. *The Journal of Experimental Biology* 150: 221-231.
- Hanrahan, J.W. and Phillips, J.E. (1982) Electrogenic, K⁺-dependent chloride transport in locust hindgut. *Philosophical Transactions of the Royal Society London B* 299: 585-595.
- Hatle, J.D., Spring, J.H. and Dow, J.A.T. (2002) Ion and water transport in the orthopteran alimentary canal: a comparison of Mantidae and Acrididae. *Journal of Orthoptera Research* 11: 19-24.
- Heimlich, G., Bortner, C.D. and Cidlowski, J.A. (2004) Apoptosis and cell volume regulation the importance of ions and ion channels. *Advances in Experimental Medicine and Biology* 559: 189-203.
- Hoffmann, J.A., Kafatos, F.C., Janeway, C.A. and Ezekowitz, R.A.B. (1999) Phylogenetic perspectives in innate immunity. *Science* 284: 1313-1318.
- Hosler, J.S., Burns, J.E. and Esch, H.E. (2000) Flight muscle resting potential and species-specific differences in chill-coma. *Journal of Insect Physiology* 46: 621-627.
- Hoyle, G. (1953) Potassium ions and insect nerve muscle. *The Journal of Experimental Biology* 30: 121-135.
- Judge, K.A. (2010) Female social experience affects the shape of sexual selection on males. *Evolutionary Ecology Research* 12: 389-402.
- Klein, U., Koch, A. and Moffett, D.F. (1996) Ion transport in Lepidoptera. In *Biology of the Insect Midgut* (eds. M. J. Lehane and P. F. Billingsley), pp. 236-264. London: Chapman and Hall.
- Klok, C.J. and Chown, S.L. (1997) Critical thermal limits, temperature tolerance and water balance of a sub-Antarctic caterpillar, *Pringleophaga marioni* (Lepidoptera: Tineidae). *Journal of Insect Physiology* 43: 685-694.
- Koštál, V., Renault, D., Mehrabianová, A. and Bastl, J. (2007) Insect cold tolerance and repair of chill-injury at fluctuating thermal regimes: role of ion homeostasis. *Comparative Biochemistry and Physiology A* 147: 231-238.
- Koštál, V. and Tollarová-Borovanská, M. (2009) The 70 kDa heat shock protein assists during the repair of chilling injury in the insect, *Pyrrhocoris apterus*. *PLoS ONE* 4: e4546.

- Koštál, V., Vambera, J. and Bastl, J. (2004) On the nature of pre-freeze mortality in insects: water balance, ion homeostasis and energy charge in the adults of *Pyrrhocoris apterus*. *The Journal of Experimental Biology* 207: 1509-1521.
- Koštál, V., Yanagimoto, M. and Bastl, J. (2006) Chilling-injury and disturbance of ion homeostasis in the coxal muscle of the tropical cockroach (*Nauphoeta cinerea*). *Comparative Biochemistry and Physiology B* 143: 171-179.
- Kristiansen, E. and Zachariassen, K.E. (2001) Effect of freezing on the transmembrane distribution of ions in freeze-tolerant larvae of the wood fly *Xylophagus cinctus* (Diptera, Xylophagidae). *Journal of Insect Physiology* 47: 585-592.
- Lang, F., Huber, S.M., Szabo, I. and Gulbins, E. (2007) Plasma membrane ion channels in suicidal cell death. *Archives of Biochemistry and Biophysics* 462: 189-194.
- Lee, R.E. (2010). A primer on insect cold-tolerance. In *Low Temperature Biology of Insects* (eds. D. L. Denlinger and R. E. Lee), pp. 3-34. Cambridge: Cambridge University Press.
- Lee, R.E., Costanzo, J.P., Mugano, J.A. (1996) Regulation of supercooling and ice nucleation in insects. *European Journal of Entomology* 93: 405-418.
- Leech, C.A. (1986) Resting potential and potassium-selective electrode measurements in locust skeletal muscles. *The Journal of Experimental Biology* 122: 439-442.
- Loughton, B.G. and Tobe, S.S. (1969) Blood volume in the African migratory locust. *Canadian Journal of Zoology* 47: 1333-1336.
- MacMillan, H. A. and Sinclair, B. J. (2011). The role of the gut in insect chilling injury: cold-induced disruption of osmoregulation in the fall field cricket, *Gryllus pennsylvanicus*. *The Journal of Experimental Biology* 214: 726-734.
- Mattson, M.P. and Chan, S.L. (2003). Calcium orchestrates apoptosis. *Nature Cell Biology* 5: 1041-1043.
- Mellanby, K. (1939) Low temperature and insect activity. *Proceedings of the Royal Society of London Series B* 127: 473-487.
- O'Donnell, M. (2008). Insect excretory mechanisms. In *Advances in Insect Physiology* V.35 (ed. S. J. Simpson), pp. 1-122. Amsterdam: Academic Press.
- O'Donnell, M. (2009). Too much of a good thing: how insects cope with excess ions or toxins in the diet. *The Journal of Experimental Biology* 212: 363-372.
- Pannabecker, T. (1995). Physiology of the Malpighian tubule. *Annual Review of Entomology* 40: 493-510.

- Patlak, J.B. (1976). Ionic basis for action potential in flight muscle of the fly, *Sarcophaga bullata*. *Journal of Comparative Physiology A* 107: 1-11.
- Phillips, J.E. (1964) Rectal absorption in the desert locust, *Schistocerca gregaria* Forskal: II. sodium, potassium and chloride. *The Journal of Experimental Biology* 41: 39-67.
- Phillips, J.E., Meredith, J., Spring, J. and Chamberlin, M. (1982) Control of ion reabsorption in locust rectum: Implications for fluid transport. *Journal of Experimental Zoology* 222: 297-308.
- Pörtner, H.-O., Bennett, A.F., Bozinovic, F., Clarke, A., Lardies, M.A., Lucassen, M., Pelster, B., Schiemer, F. and Stillman, J.H. (2006) Trade-offs in thermal adaptation: the need for a molecular to ecological integration. *Physiological and Biochemical Zoology* 79: 295-313.
- Quinn, P.J. (1985) A lipid-phase separation model of low-temperature damage to biological membranes. *Cryobiology* 22: 128-146.
- Rakshpal, R. (1962) Diapause in the eggs of *Gryllus pennsylvanicus* Burmeister (Orthoptera: Gryllidae). *Canadian Journal of Zoology* 40: 179-194.
- Ramsay, J.A. (1954). Active transport of water by the Malpighian tubules of the stick insect, *Dixippus morosus* (Orthoptera, Phasmidae). *The Journal of Experimental Biology* 31: 104-113.
- Ramsay, J.A. (1971) Insect rectum. *Philosophical Transactions of the Royal Society London B* 262: 251-260.
- Rodgers, C.I., Armstrong, G.A.B. and Robertson, R.M. (2010) Coma in response to environmental stress in the locust: A model for cortical spreading depression. *Journal of Insect Physiology* 56: 980-990.
- Rojas, R.R. and Leopold, R.A. (1996) Chilling injury in the housefly: Evidence for the role of oxidative stress between pupariation and emergence. *Cryobiology* 33: 447-458.
- Samaranayaka, M. (1977) The effect of insecticides on osmotic and ionic balance in the locust *Schistocerca gregaria*. *Pesticide Biochemistry and Physiology* 7: 510-516.
- Semper, C. (1883) *The Natural Conditions of Existence as they Affect Animal Life*. London: Kegan Paul, Trench and Co.
- Spring, J.H., Robichaux, S.R. and Hamlin, J.A. (2009) The role of aquaporins in excretion in insects. *The Journal of Experimental Biology* 212: 358-362.

- Staszak, D.J. and Mutchmor, J.A. (1973) Influence of temperature on chill-coma and the electrical activity of central and peripheral nervous systems of American cockroach, *Periplaneta americana*. *Comparative Biochemistry and Physiology A* 45: 909-923.
- Treherne, J.E. and Schofield, P.K. (1979) Ionic homeostasis of the brain microenvironment in insects. *Trends in Neuroscience* 2: 227-230.
- Wieczorek, H., Putzenlechner, M., Zeiske, W. and Klein, U. (1991) A vacuolar-type proton pump energizes K^+/H^+ antiport in an animal plasma membrane. *Journal of Biological Chemistry* 266: 15340-15347.
- Wood, D.W. (1957) The effect of ions upon neuromuscular transmission in a herbivorous insect. *Journal of Physiology* 138: 119-139.
- Yi, S.-X., Moore, C.W. and Lee, R.E. (2007) Rapid cold-hardening protects *Drosophila melanogaster* from cold-induced apoptosis. *Apoptosis* 12: 1183-1193.
- Yocum, G.D. (2001) Differential expression of two HSP70 transcripts in response to cold shock, thermoperiod, and adult diapause in the Colorado potato beetle. *Journal of Insect Physiology* 47: 1139-1145.
- Zachariassen, K.E., Kristiansen, E. and Pedersen, S.A. (2004) Inorganic ions in cold-hardiness. *Cryobiology* 48: 126-133.

Chapter 5

5 Reestablishment of ion homeostasis during chill-coma recovery in the cricket *Gryllus pennsylvanicus*

A modified version of this chapter was published in *Proceedings of the National Academy of Sciences of the United States of America* (MacMillan et al., 2012a).

5.1 Introduction

Temperature limits the geographic range of many terrestrial ectotherms (Chen et al., 2011), and understanding the mechanisms that underlie this limitation will allow predictions regarding species' sensitivity to climate change (Chen et al., 2011; Chown et al., 2010). At low temperatures, insects enter chill-coma; a reversible state of paralysis (Mellanby, 1939). The time taken to recover from this paralysis (chill-coma recovery time; CCR) is one of the most common metrics of insect cold tolerance (e.g. Gibert et al., 2001; Kellermann et al., 2009, Overgaard et al., 2011), and has been used to develop and test theory in biogeography (Hoffmann et al., 2002; David et al., 2003; Castañeda et al., 2005; Sisodia and Singh, 2010; Overgaard et al., 2011), evolution (Kellermann et al., 2009), and climate change biology (Terblanche et al., 2008; Bozinovic et al., 2011). Variation in CCR reflects variation in low temperature exposure in the wild; for example, CCR is faster in individuals collected from populations or species at higher altitudes or latitudes, suggesting selection for faster recovery in cooler environments (Gibert et al., 2001; Hoffmann et al., 2002). In *Drosophila melanogaster*, CCR can be modified in laboratory experiments through thermal acclimation (Gibert and Huey, 2001; Ransberry et al., 2011), and artificial selection (e.g. Anderson et al., 2005; Mori and Kimura, 2008; Bertoli et al., 2010; Morgan and Mackay, 2006; Telonis-Scott et al., 2009).

Genomic and transcriptomic screens (Morgan and Mackay, 2006; Telonis-Scott et al., 2009; Norry et al. 2007; Norry et al., 2008; Clowers et al., 2010; Mackay et al., 2012) have not identified consistent candidate loci that might explain variation in CCR.

Although it is generally assumed that recovery of movement requires a reversal of the processes that led to onset of chill-coma, variation in CCR is not always accompanied by variation in chill-coma onset temperature (Ransberry et al., 2011). Thus, despite more than a decade of use as a metric of insect cold tolerance, the physiological mechanisms that set CCR remain unknown.

The onset of chill-coma is associated with an inability to maintain hemolymph osmotic homeostasis, which leads to electrophysiological failure of the neuromuscular system (Chapters 2 and 4). In the fall field cricket (*Gryllus pennsylvanicus*), a cold-induced redistribution of Na^+ and water from the hemolymph to the gut during chill-coma elevates hemolymph K^+ concentration, depolarizing muscle K^+ equilibrium potentials (E_K ; Chapter 4). Once the muscle depolarizes beyond a threshold membrane potential, contraction and/or relaxation are no longer possible and the insect is paralyzed (Hosler et al., 2000).

If recovery from chill-coma requires a reversal of the mechanisms underlying chill-coma onset, CCR will be driven by the re-establishment of muscle resting potential, which is largely determined by E_K in insects (Hoyle, 1953; Wood, 1963). I therefore predicted that recovery of hemolymph K^+ homeostasis would coincide with the recovery of movement of *G. pennsylvanicus*. Since ionic recovery would presumably depend on the action of metabolically costly ion-motive ATPase activity, I hypothesized that I could track the time-course of recovery by measuring whole-animal metabolic rate. Here I show that chill-coma recovery is coincident with recovery of hemolymph K^+ concentration resulting in the restoration of muscle membrane potentials and the capacity for movement. This recovery of K^+ is in turn dependent on an energetically costly recovery of hemolymph water content following cold exposure that continues after the ability to move is restored. Thus, chill-coma recovery as it is typically measured represents a return to the electrophysiological conditions that were lost during chill-coma, but the recovery of movement does not indicate complete osmotic recovery. These findings allow me to construct a conceptual model of chill-coma onset and recovery and generate new hypotheses of the mechanisms limiting insect thermal tolerance in a changing climate.

5.2 Materials and methods

5.2.1 Animal husbandry

Gryllus pennsylvanicus were maintained in a laboratory colony as previously described (Chapters 3 and 4). All experiments were completed on gravid adult females, approximately three weeks post final molt. Cold exposures began between 10:00h and 14:00h to control for any diel patterns in thermal tolerance.

5.2.2 Chill-coma recovery time

A total of 60 crickets were placed individually into 14 mL plastic tubes and cooled from 25 °C at 0.25 °C min⁻¹ and held at 0 °C for 2-42 h. At 2 h intervals (first 24 h), and every 6 h thereafter, four crickets were placed on their dorsum in a Petri dish at room temperature. Times of four indices of chill-coma recovery were recorded: 1) first foreleg movement; 2) first hind leg movement; 3) initiation of abdominal contractions (active ventilation), and 4) righting. Foreleg and hind leg movement were identified as a coordinated directional movement of the limbs, distinct from twitches of the limbs observed during rewarming. If crickets had not righted within 3 h of removal from the cold, they were considered to have incurred chilling-injury that precluded recovery.

5.2.3 Measurement of ion and water balance

Hemolymph volume was estimated gravimetrically because the inulin dilution method cannot be used, as the heart does not function in chill-coma. Instead, I corrected my estimates of hemolymph volume and accounted for residual hemolymph content of muscle samples (4.14 % w/v) using the inulin dilution technique (Ziegler et al., 2000; Qi et al., 2004) on 19 crickets at 22 °C temperature (Figure 5.1). A 5 % w/v solution of FITC inulin in 150 mM NaCl was dialyzed in the dark and at room temperature against 150 mM NaCl (to remove unbound FITC) in benzoylated dialysis tubing with a molecular weight cut-off of 2 kDa (Sigma Aldrich, St. Louis, MO, USA) and the resulting solution (~3 % w/v FITC-inulin) was used for injection.

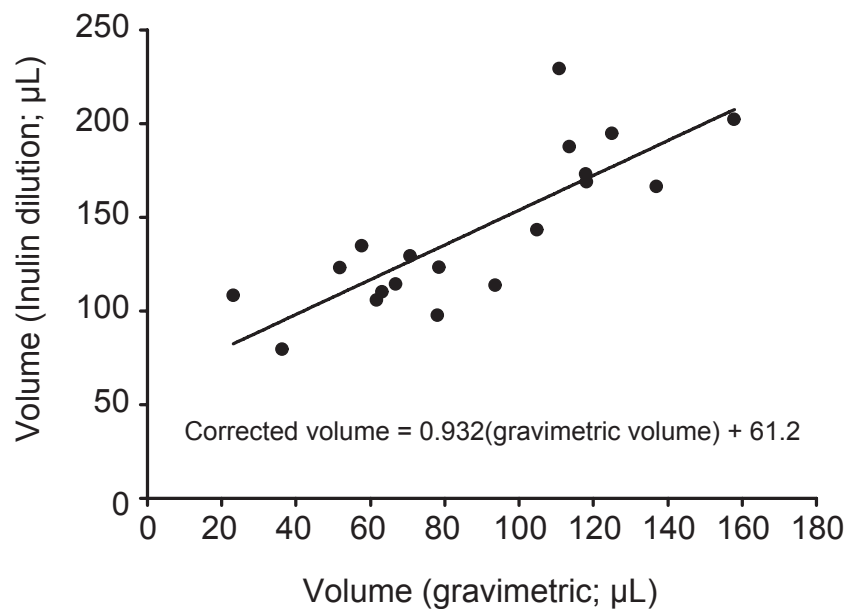

Figure 5.1. The relationship between gravimetric estimates of hemolymph volume and volume quantified using the inulin dilution method in *G. pennsylvanicus*. Gravimetric estimates of hemolymph volume significantly correlated ($P_{intercept} < 0.001$; $P_{slope} < 0.001$, $R^2 = 0.66$) with estimates obtained on the same individuals using the inulin dilution method.

Crickets were immobilized using plasticine and vacuum grease was applied to the injection site to minimize bleeding. A 2 μL bolus of the inulin solution was injected at the base of the right wing under the pronotum. Fifteen minutes later the crickets were sampled as above to collect hemolymph and muscle tissue. Muscle tissue from one femur was used to measure water content gravimetrically. The hemolymph and muscle tissue from the other femur were weighed and placed in 20 volumes of 500 mM HEPES buffer (pH 7.4), homogenized at 22 $^{\circ}\text{C}$ using a bullet blender with 1 mm glass beads (Next Advance, Averill Park, NY, USA), and centrifuged at $7000 \times g$ for 10 minutes. 50 μL aliquots of the resulting supernatant were loaded onto black 96-well plates and fluorescence measured (excitation=485 nm, emission=538 nm) in a Spectramax M2e spectrophotometer (Molecular Devices, New Milton, Hampshire, UK). Sample fluorescence was compared to dilutions of the 3 % injection solution in 500 mM hepes and corrected by comparison to hemolymph and muscle tissue of three control crickets that did not receive an injection. Gravimetric estimates of hemolymph volume significantly correlated ($P_{intercept} < 0.001$; $P_{slope} < 0.001$, $R^2 = 0.66$) with estimates obtained on the same individuals using the inulin dilution method.

Crickets were cooled from 25 $^{\circ}\text{C}$ at 0.25 $^{\circ}\text{C min}^{-1}$ and held at 0 $^{\circ}\text{C}$. After 24 h, ten crickets were removed to 4 $^{\circ}\text{C}$ and immediately dissected ($t=0$; ~ 3 min per dissection), while 40 crickets were removed to 22 $^{\circ}\text{C}$ and dissected after 5, 20, 60 and 120 min of recovery ($n=10$ at each time point). Control crickets were dissected directly from rearing conditions (25 $^{\circ}\text{C}$). Tissue collection and ion content analysis followed previously described methods (Chapter 4). Briefly, hemolymph was collected from incisions at the base of each hind limb, the thorax and abdomen were then opened dorsally and any additional hemolymph was collected. Muscle tissue was collected from the hind femurs and blotted gently to remove residual hemolymph. Foregut, midgut and hindgut were ligated (to retain their contents) at the junctions between the proventriculus and midgut, and midgut and hindgut, before being removed. All tissue samples were placed into pre-weighed 200 μL tubes. Tissue water content was determined gravimetrically from the mass before and after being dried at 70 $^{\circ}\text{C}$ for 48 h. A 200 μL aliquot of nitric acid was added to the dried samples which were digested for 24 h at room temperature and stored at -20 $^{\circ}\text{C}$ for up to 3 weeks before analysis. Total tissue Na^+ and K^+ content were

determined using atomic absorption spectroscopy (iCE 3300, Thermo Scientific, Waltham, Ma, USA) by comparisons to standard curves. Muscle equilibrium potentials were calculated using the Nernst equation.

5.2.4 Respirometry

I used open-flow respirometry to measure mass-specific rates of CO₂ production ($\dot{V}CO_2$) as a proxy for metabolic rate during recovery from a range of exposures to 0 °C (1-24 h). CO₂ production was recorded using flow-through respirometry (Chapter 3; Williams et al., 2010). Briefly, crickets were individually placed into a glass 11 cm³ chamber in a temperature-controlled cabinet (PTC1, Sable Systems International (SSI), Las Vegas, Nevada, USA). Activity in the chamber was detected with an AD-1 infrared activity detector and temperature by a 36 AWG type-T thermocouple held in place against the outside of the glass near the cricket. Dry, CO₂-free air was pushed through the chamber at 50 mL·min⁻¹ (mass flow valve: Sierra Instruments, Monterey, California, USA and control unit MFC2, SSI). [CO₂] and [H₂O vapor] were measured in the excurrent air (Li7000, LiCor, Lincoln, Nebraska, USA). All data were recorded via a UI2 interface and Expedata software (SSI), and baseline recordings made for 10 min before and after each run using an empty chamber. [CO₂] was corrected for dilution by water vapor and converted to $\dot{V}CO_2$ (mL min⁻¹ g⁻¹).

A total of 45 crickets were used to record $\dot{V}CO_2$ during chill-coma recovery. Prior to cold exposure, crickets were removed from their rearing conditions and held for 2 h in the respirometry chamber before $\dot{V}CO_2$ was measured for 1 h at 22 °C. They were then transferred to a 14 mL plastic tube, which was placed in a well in an aluminum block cooled by fluid circulating from a Proline RP855 circulating bath (Lauda, Wurzburg, Germany). The crickets were allowed 15 min equilibration at 22 °C before being cooled at 0.25 °C min⁻¹ to 0 °C where they were held for 1 - 24 h. After cold exposure, each cricket was placed upright in the respirometry chamber at 22 °C, and $\dot{V}CO_2$ recorded during recovery. The time of the first movement of the cricket was recorded from the activity trace. The duration of recording $\dot{V}CO_2$ during recovery was modified based on preliminary observations of metabolic overshoot: 4 h (1-2 h at 0 °C), 6 h (3-8 h at 0 °C)

or 8 h (9-24 h at 0 °C). Six control crickets that were not exposed to cold were recorded twice in the respirometer with a one hour rest at 22 °C between recordings. There was no difference in $\dot{V}CO_2$ between the first and second recording ($P=0.102$), and no evidence of a metabolic overshoot during the second recording.

5.2.5 Data analysis

Statistical analyses were conducted with R (v. 2.13; R Core Development Team, 2011). Linear and exponential models of the relationship between cold exposure duration and chill-coma recovery times were fitted using the `gnls()` function in R and compared with the Akaike information criterion (AIC), where $\Delta AIC \geq 2$ indicated a better model.

To account for changes in both ion and water content during cold exposure, ion data are expressed as both concentration and total tissue content. Tissue water and ion content both significantly correlated with tissue dry mass ($P < 0.001$), so analyses of water and ion content of the tissues (excluding those of the hemolymph) were performed on residuals of a regression of content and dry mass. Ion concentrations, ion content and water content for each tissue were first compared between control conditions and immediately following cold exposure using t-tests followed by false discovery rate (FDR) correction (Benjamini and Hochberg, 1995) using the `p.adjust()` function in R. The relationship between time and water or ion content during chill-coma recovery were then determined by fitting to both linear and exponential models using the `gnls()` function in R, and models FDR corrected and compared with AIC as above.

Crickets were excluded from the respirometry analyses if they died within 24 h of the experiment ($n=3$) or displayed excessive activity during respirometry ($n=7$). Respirometry activity data were converted to absolute difference sum (ADS; Lighton and Turner, 2004). A ten-minute period with the lowest ADS slope, indicating minimal activity, was used to calculate a mean $\dot{V}CO_2$ for each cricket prior to cold exposure (Chapter 3). Mean $\dot{V}CO_2$ following cold exposure was estimated using the same method for only the final 25 % of the recording to ensure metabolic rate had stabilized post-cold exposure. Pre- and post-cold exposure $\dot{V}CO_2$ data were compared using the `avov()` function (with mass as a covariate) to examine the effect of cold exposure on resting metabolic

rate. To estimate the time at which the transient rise in metabolic rate during chill-coma recovery was completed, the point at which metabolic rate crossed the mean metabolic rate post-recovery as determined above was used. The total time required for the metabolic overshoot to end was then determined from the point at which the cricket was removed from the cold and placed in the respirometry chamber at 22 °C.

The exponential loss of Na⁺ content from the hemolymph as a function of cold exposure duration was estimated using compiled Na⁺ content data from the present study and from a previous study of the same cricket population (Chapter 4). The time required to restore Na⁺ content was then estimated using the slope of the linear regression of hemolymph Na⁺ content against time (Figure 5.3C), and these rates were used to estimate the time required to restore hemolymph Na⁺ content to control levels as a function of cold exposure duration.

Detailed statistical results of model fit for this chapter are presented in Appendix B (Tables B.1-B.3).

5.3 Results and discussion

5.3.1 Chill-coma recovery

I examined CCR in *G. pennsylvanicus* exposed to 0 °C. The time required for crickets to recover movement of the abdomen and legs increased exponentially with the duration of exposure to 0 °C; after more than 12 h of cold exposure, recovery time reached a plateau at c. 15 min (Figure 5.2A, Table B.1). CCR is usually measured as the time taken for a coordinated righting response. When this measure is used, recovery time also increased exponentially with increasing exposure time, but became more variable after exposure to 0 °C for more than 24 h, and some crickets did not recover within 3 h (Figure 5.2B). This second, variable phase beyond 24 h corresponds with the time-course over which *G. pennsylvanicus* begin to accumulate irreversible chilling injury, which manifests as a permanent loss of muscle control, and eventual death (Chapter 4). Thus the increase in

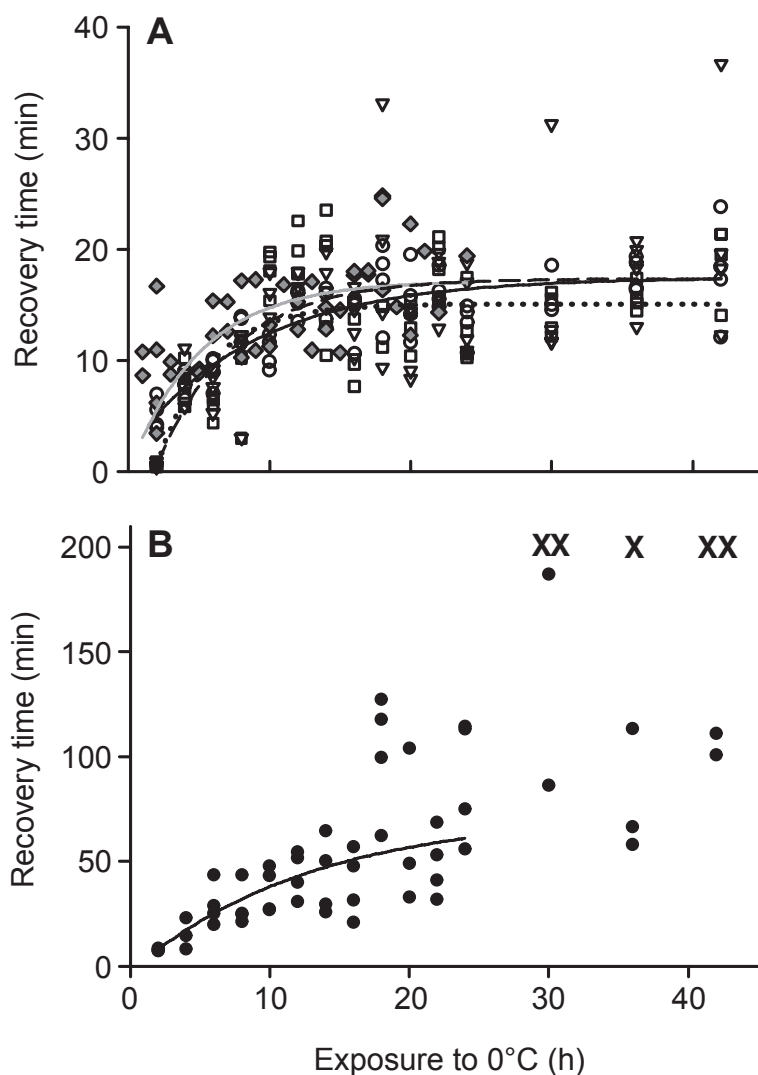

Figure 5.2. Time taken for female *G. pennsylvanicus* to recover movement after exposure to 0 °C. (A) Time until the first abdominal contraction (circles, solid black line), foreleg (squares, dashed line) and hind leg movements (triangles, dotted line) and time until first movement detected during respirometry (grey diamonds, grey line). (B) Time taken for crickets to exhibit a coordinated righting response after exposure to 0 °C. × indicates individuals that did not right themselves within 180 min. The relationship is exponential until c. 24 h at 0 °C, after which there is no significant relationship, suggesting an additional effect from chilling injury. See Appendix B, Table B.1 for statistics.

the mean and variance of CCR beyond 24 h of cold exposure likely results from chilling injury that impairs coordinated movement, but does not affect the ability to move isolated groups of muscles. Similar biphasic patterns have been observed in chill-coma recovery of *Drosophila* exposed to varying temperatures (David et al., 2003; Macdonald et al., 2004). I suggest that CCR (as a righting response) should be measured following relatively mild cold-exposures to avoid confounding recovery from chill-coma with time- or temperature-dependent chilling injury.

5.3.2 Loss and recovery of ion concentration, ion content and muscle equilibrium potentials

As previously reported (Chapter 4), exposure to 0 °C for 24 h led to a decrease in hemolymph $[Na^+]$ ($P=0.017$) but did not alter muscle Na^+ equilibrium potentials (E_{Na} ; $P=0.582$; Figure 5.3B), possibly due to a concurrent decrease in intracellular Na^+ concentration (Appendix B, Figure B.1). Cold exposure decreased hemolymph Na^+ content and reduced hemolymph volume, which was accompanied by a similar increase in gut volume (Figure 5.3C,D). There was a consequent increase in hemolymph $[K^+]$ ($P=0.024$; Figure 5.3A), and E_K repolarized to approximately -40 mV ($P=0.025$; Figure 5.3B). Hemolymph K^+ content remained unchanged (Figure 5.3C), so recovery of E_K is driven by the increase in $[K^+]$, in turn caused by the loss of hemolymph volume to the gut.

I hypothesized that if chill-coma results from the loss of ion homeostasis, then CCR should correspond to the re-establishment of ion potentials necessary for muscle contraction. During recovery at 22 °C following 24 h at 0 °C, hemolymph $[Na^+]$ returned to control levels within 5 min, while $[K^+]$ decreased to control levels within 20 min ($P=0.008$; Figure 5.3A). Recovery of muscle E_K ($P=0.001$; Figure 5.3B) followed a similar time course, which agreed closely with the mean time (c. 15 min) required for crickets to recover movement (Figure 5.3A). Taken together, these support the hypothesis that chill-coma in *G. pennsylvanicus* is caused by a lack of ion homeostasis, and recovery occurs when K^+ homeostasis is restored. Unlike muscle, insect nervous tissue is protected from transient alterations in hemolymph composition by the blood-brain and blood-nerve

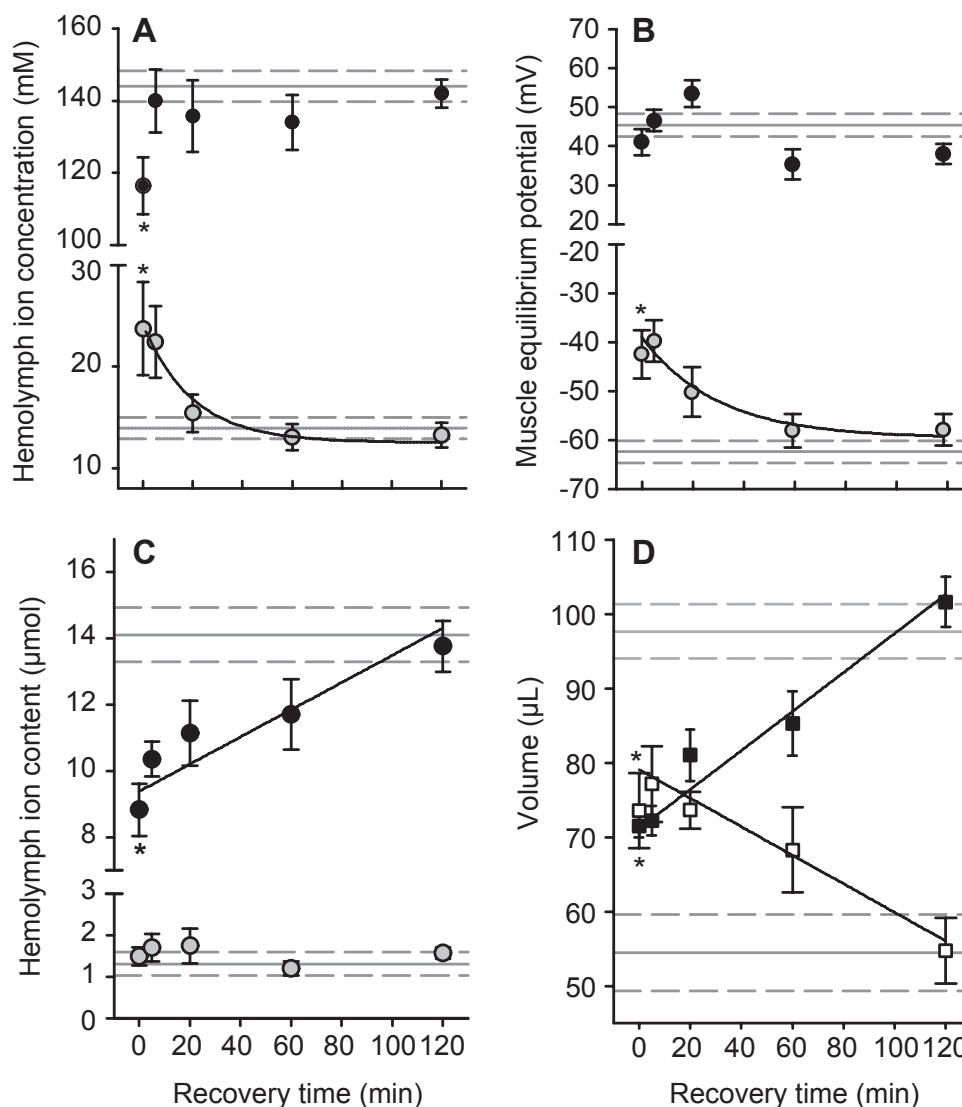

Figure 5.3. Hemolymph concentration (A), muscle equilibrium potential (B), total hemolymph ion content (C) of Na⁺ (black) and K⁺ (grey), and (D) hemolymph volume (filled squares) and gut water content (open squares) of female *G. pennsylvanicus* during recovery at 22 °C following 24 h at 0 °C. . All values are mean ± sem. Values from control (not cold-exposed) crickets are shown as solid (mean) and dashed (± sem) grey horizontal lines. Asterisks denote a significant difference between control and 0 h time points (a significant effect of cold exposure), and black lines denote a significant relationship between a parameter and recovery time at 22 °C (see Appendix B, Tables B.2 and B.3 for statistics).

barriers (Leiserson and Keshishian, 2011), which suggests that this hemolymph composition-driven loss of excitability may primarily affect the muscle. However, declining temperatures do increase extracellular $[K^+]$ of locust neurons *in vitro*, which would lead to temperature-sensitive electrical silence of the nervous system as well (Rodgers et al., 2010).

I observed a linear recovery of hemolymph volume and Na^+ following cold exposure that closely followed the decreasing gut water content ($P < 0.001$; Figure 5.3C,D), suggesting that recovery of hemolymph volume involves movement of water and Na^+ from the gut back into the hemolymph. The exponential decline in hemolymph $[K^+]$ is consistent with a linear increase in hemolymph volume with a constant hemolymph K^+ content. Thus, it appears that the re-establishment of K^+ homeostasis is driven largely by the redistribution of water.

Water likely follows Na^+ redistribution from the gut lumen to the hemocoel during recovery of hemolymph osmotic homeostasis. The majority of Na^+ removed from the gut during recovery was moved from the hindgut to the hemolymph, while K^+ accumulated in the hindgut during recovery (Appendix B, Figure B.2). The hindgut epithelium has high water permeability and ion-motive ATPase activity, and is a primary site of whole-animal Na^+ and water balance in insects (Phillips, 196; Phillips et al., 1982). Isolated hindguts of the desert locust *Schistocerca gregaria* (Orthoptera, Acrididae) can transport fluid at $14 \mu L \cdot h^{-1}$ at $22 \text{ }^\circ C$ (Phillips et al., 1982). If the hindgut of *G. pennsylvanicus* has similar capacity, most of the water moved back to the hemolymph during chill-coma recovery could be transported through the hindgut. There is, however, variation in the mechanisms regulating ion and water homeostasis among insect species, especially related to the rich variety of insect diets (O'Donnell, 2009), which may affect the exact nature of ionoregulation during CCR across the insect phylogeny.

5.3.3 Recovery of osmotic homeostasis after cold exposure is metabolically costly

Before cold exposure and at rest, mean $\dot{V}CO_2$ of female *G. pennsylvanicus* was $2.01 \pm 0.13 \text{ mL CO}_2 \text{ h}^{-1} \text{ g}^{-1}$. Following cold exposure, the timing of the first movements

recorded from an infra-red activity detector was consistent with recovery of muscle function recorded visually (Figure 5.2A). Following complete osmotic recovery, $\dot{V}CO_2$ at rest was 22.9 ± 2.8 % (mean \pm sem) lower than before cold exposure ($P < 0.001$), indicating an overall reduction in metabolic rate for several hours following cold exposure.

I detected a transient increase in $\dot{V}CO_2$ during recovery from chill-coma (Figure 5.4). The duration of this metabolic ‘overshoot’ increased with cold exposure duration from approximately 21 min (after 1 h at 0 °C) to 111 min following 24 h at 0 °C ($P < 0.001$; Figure 5.5). The volume of additional CO_2 emitted during this overshoot also significantly correlated with cold exposure duration ($P < 0.001$). Increased activity was detected by the infra-red activity detector during the metabolic overshoot (Figure 5.4B). This apparent increase in activity is almost entirely due to active ventilation, since crickets remained stationary but exhibited regular abdominal contractions during this recovery overshoot period (Appendix B, Video B.1). A similar metabolic overshoot following cold exposure was reported in a tropical tenebrionid beetle (*Alphitobius diaperinus*; Lalouette et al., 2011).

The metabolic overshoot following cold exposure continues beyond the time taken for the crickets to regain movement. If this overshoot reflects the metabolic cost of restoring osmotic balance after exposure to cold, then the duration of the metabolic overshoot should correspond with the time required for full recovery of hemolymph Na^+ content. I used the observed rates of Na^+ flux between the hemocoel and gut lumen of crickets during exposure to and recovery from cold (Figure 5.3C), to estimate the time taken for complete recovery of hemolymph Na^+ content as a function of cold exposure duration. The estimated time required to recover hemolymph Na^+ content (118 min after 24 h of cold exposure) was in agreement with the duration of metabolic overshoot observed during chill-coma recovery (Figure 5.5). While these recovery times share a similar maximum, the exponents of these relationships differ slightly, suggesting a metabolic cost to recovery (perhaps associated with K^+ regulation) additional to the cost of

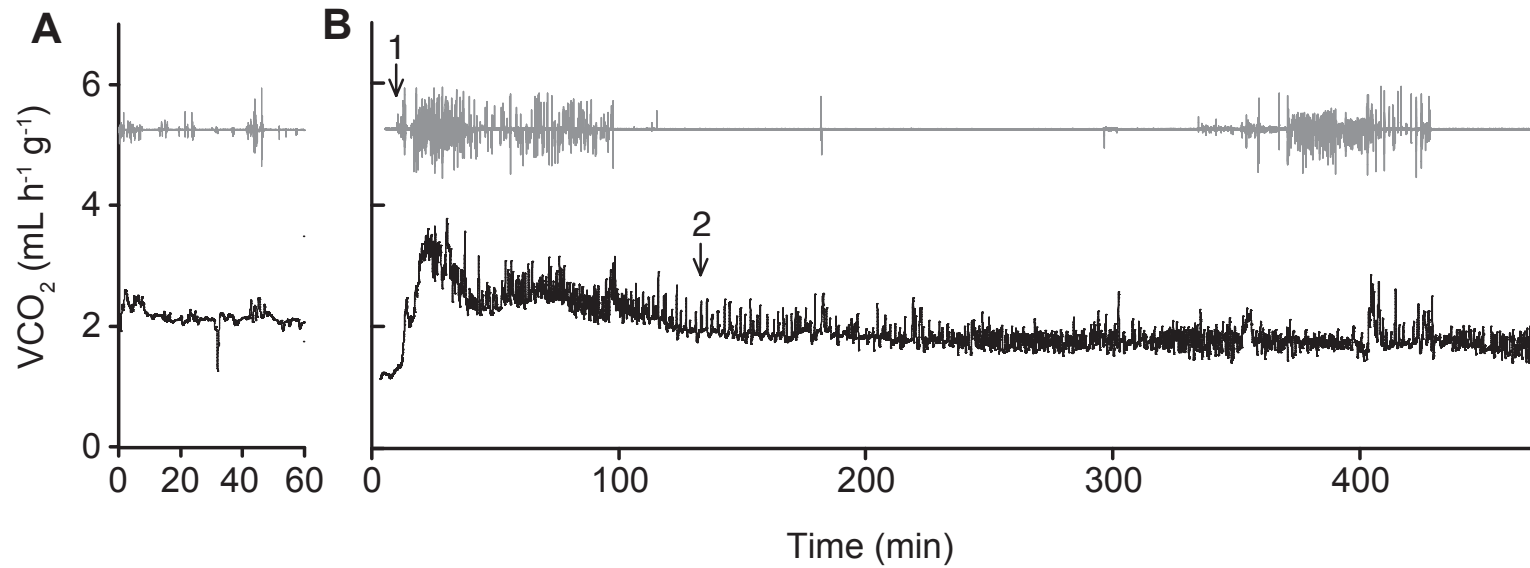

Figure 5.4. An example measurement of metabolic rate (rate of CO₂ emission, black line, baseline-corrected values shown) and activity (grey line, arbitrary units) of a *G. pennsylvanicus* female (A) prior to and (B) immediately upon removal from a 20 h exposure to 0 °C. The cricket was placed into the chamber approximately 2 mins before recording from the animal chamber began. Arrows indicate (1) the first detection of movement from the animal chamber and (2) the end of metabolic overshoot (see methods for details).

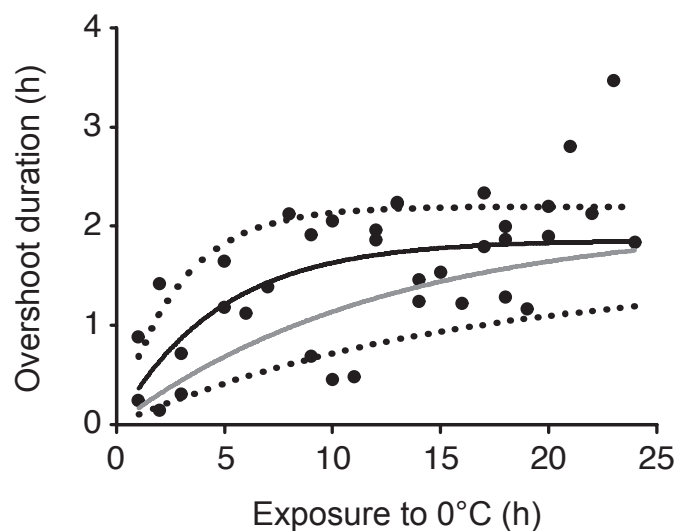

Figure 5.5. The relationship between the duration of metabolic overshoot during chill-coma recovery and exposure to 0 °C (solid circles). The time for crickets to complete the metabolic overshoot followed an exponential rise to a maximum (black line). Dotted lines denote 95 % confidence intervals of the relationship between overshoot duration and cold exposure. Estimated time to recovery of hemolymph Na⁺ content (grey line) is calculated from the observed rate of Na⁺ flux between the gut lumen and hemocoel during cold exposure and rewarming and strongly agreed with observed overshoot durations.

hemolymph Na^+ recovery. Thus, the metabolic overshoot during chill-coma recovery likely reflects the full cost of recovery of ion and water balance that is not accounted for in typical measures of chill-coma recovery.

5.3.4 A conceptual model of chill-coma onset and recovery

The current conceptual model of chill-coma onset (see 2.4.3) posits that the rate of ion pumping decreases in the cold, while ion leak across membranes is largely temperature-independent. Thus, chill-coma occurs at a temperature where the rate of ion pumping no longer outpaces leak and muscle cells depolarize past an excitability threshold. I propose that, in *G. pennsylvanicus* (and likely other insects), the rates of ion transport and leak in the gut epithelia are critical to chill-coma recovery through their effects on muscle resting potential, and present a conceptual model of chill-coma onset and recovery during a typical cold exposure and recovery (Figure 5.6). According to this model, chill-coma onset is determined by the temperature sensitivity of pumping rate and membrane ion permeability, as well as the muscle excitability threshold. I suggest that recovery of movement occurs when ion pumping across the gut epithelia restores muscle resting potentials to the excitability threshold (Figure 5.5). CCR may therefore be dependent on: 1) the difference between rates of ion pumping and leak at the recovery temperature (i.e. the absolute rate at which ion concentrations are restored), 2) the rates at which water traverses the hindgut epithelium during both cold exposure and recovery, 3) the excitability threshold of the muscle, and 4) how far muscle potentials have deviated from the excitability threshold during chill-coma (dependent on the duration and temperature of cold exposure; Figure 5.6). I hypothesize that both evolution and phenotypic plasticity could cause variation in any of these parameters, and that such variation (particularly variation influencing the second and fourth processes) may not affect chill-coma onset and chill-coma recovery equally, leading to a lack of correlation between the parameters (Ransberry et al., 2011).

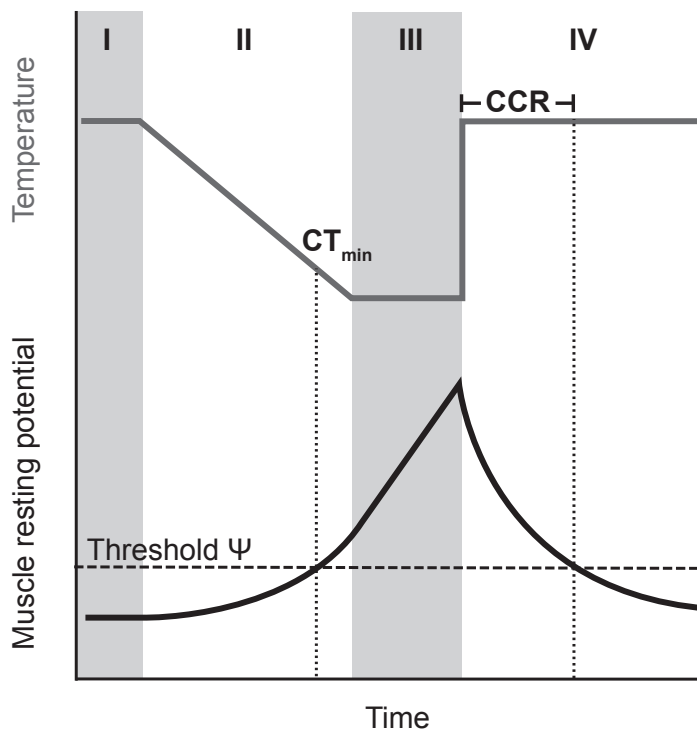

Figure 5.6. A conceptual model of the effects of temperature (grey line) on muscle resting potential (black line) of a chill-susceptible insect during a typical experimental cold exposure. **I.** At permissive temperatures muscle resting potentials are maintained in a polarized state. **II.** As temperature declines linearly, muscle resting potentials are depolarized exponentially until a threshold potential (Ψ) is reached beyond which the muscle cannot undergo an action potential (the temperature at which this occurs is the chill-coma onset temperature, or CT_{min}). The exponent of the relationship between resting potential and time is dependent on the rate of temperature decline, and the measured CT_{min} is thereby dependent on the cooling rate. **III.** If temperature remains static below the CT_{min} , continued Na^+ and water flux to the gut further depolarizes muscle resting potential in a linear manner. **IV.** When removed back to the permissive temperature, Na^+ and water are relocated to the hemolymph, causing an exponential repolarization of muscle E_K (and thus resting potential repolarization; Figure 5.2B). The time required for muscle resting potential to cross the threshold potential for movement sets chill-coma recovery time (CCR).

This conceptual model leads to strong hypotheses about the mechanisms underlying variation in insect cold tolerance, for example that variation in CCR may be driven by differences in ion-motive ATPase activity, or transcellular and paracellular pathways of water movement across gut epithelia. These findings provide new avenues of study in the physiological and genetic basis of adaptive variation in insect cold tolerance that will improve predictions of insect biogeography in a changing climate.

5.4 Literature cited

- Anderson A.R., Hoffmann A.A. and McKechnie S.W. (2005) Response to selection for rapid chill-coma recovery in *Drosophila melanogaster*: physiology and life-history traits. *Genetical Research* 85: 15–22.
- Benjamini, Y. and Hochberg, Y. (1995) Controlling the false discovery rate: a practical and powerful approach to multiple testing. *Journal of the Royal Statistical Society B* 57: 289–300.
- Bertoli, C.I., Scannapieco, A.C., Sambucetti, P. and Norry, F.M. (2010) Direct and correlated responses to chill-coma recovery selection in *Drosophila buzzatii*. *Entomologia Experimentalis et Applicata* 134: 154–159.
- Bozinovic, F., Bastias, D.A., Boher, F., Clavijo-Baquet, S., Estay, S.A. and Angilletta, M.J. Jr. (2011) The mean and variance of environmental temperature interact to determine physiological tolerance and fitness. *Physiological and Biochemical Zoology* 84: 543–552.
- Castañeda, L.E., Lardies, M.A. and Bozinovic, F. (2005) Interpopulational variation in recovery time from chill coma along a geographic gradient: a study in the common woodlouse, *Porcellio laevis*. *Journal of Insect Physiology* 51: 1346–1351.
- Chen, I.C., Hill, J.K., Ohlemüller, R., Roy, D.B. and Thomas, C.D. (2011) Rapid range shifts of species associated with high levels of climate warming. *Science* 333: 1024–1026.
- Chown, S.L., Hoffmann, A.A., Kristensen, T.N., Angilletta, M.J. Jr., Stenseth, N.C. and Pertoldi, C. (2010) Adapting to climate change: a perspective from evolutionary physiology. *Climate Research* 43: 3–15.
- Clowers, K.J., Lyman, R.F., Mackay, T.F.C. and Morgan, T.J. (2010) Genetic variation in senescence marker protein-30 is associated with natural variation in cold tolerance in *Drosophila*. *Genetics Research* 92: 103–113.

- David, J.R., Gibert, P., Moreteau, B., Gilchrist, G.W. and Huey, R.B. (2003) The fly that came in from the cold: geographic variation of recovery time from low-temperature exposure in *Drosophila subobscura*. *Functional Ecology* 17: 425–430.
- Gibert, P. and Huey, R.B. (2001) Chill-coma temperature in *Drosophila*: Effects of developmental temperature, latitude, and phylogeny. *Physiological and Biochemical Zoology* 74: 429–434.
- Gibert, P., Moreteau, B., Petavy, G., Karan, D. and David, J.R. (2001) Chill-coma tolerance, a major climatic adaptation among *Drosophila* species. *Evolution* 55: 1063–1068.
- Hoffmann, A.A., Anderson, A. and Hallas, R. (2002) Opposing clines for high and low temperature resistance in *Drosophila melanogaster*. *Ecology Letters* 5: 614–618.
- Hosler, J.S., Burns, J.E. and Esch, H.E. (2000) Flight muscle resting potential and species-specific differences in chill-coma. *Journal of Insect Physiology* 46: 621–627.
- Hoyle, G. (1953) Potassium ions and insect nerve muscle. *The Journal of Experimental Biology* 30: 121–135.
- Kellermann, V., van Heerwaarden, B., Sgro, C.M. and Hoffmann, A.A. (2009) Fundamental evolutionary limits in ecological traits drive *Drosophila* species distributions. *Science* 325: 1244–1246.
- Lalouette, L., Williams, C.M., Hervant, F., Sinclair, B.J. and Renault, D. (2011) Metabolic rate and oxidative stress in insects exposed to low temperature thermal fluctuations. *Comparative Biochemistry and Physiology A* 158: 229–234.
- Leiserson, W.M. and Keshishian, H. (2011) Maintenance and regulation of extracellular volume and the ion environment in *Drosophila* larval nerves. *Glia* 59: 1312–1321.
- Lighton, J.R.B. and Turner, R.J. (2004) Thermolimit respirometry: an objective assessment of critical thermal maxima in two sympatric desert harvester ants, *Pogonomyrmex rugosus* and *P. californicus*. *The Journal of Experimental Biology* 207: 1903–1913.
- Macdonald, S.S., Rako, L., Batterham, P. and Hoffmann, A.A. (2004) Dissecting chill coma recovery as a measure of cold resistance: evidence for a biphasic response in *Drosophila melanogaster*. *Journal of Insect Physiology* 50: 695–700.
- Mackay, T.F. et al. (2012) The *Drosophila melanogaster* Genetic Reference Panel. *Nature* 482: 173–178.

- MacMillan, H. A., Williams, C.M., Staples, J.F. and Sinclair, B.J. (2012a). Reestablishment of ion homeostasis during chill-coma recovery in the cricket *Gryllus pennsylvanicus*. *Proceedings of the National Academy of Sciences* 109: 20750–20755.
- Mellanby, K. (1939) Low temperature and insect activity. *Proceedings of the Royal Society B* 127: 473–487.
- Morgan, T.J. and Mackay, T.F.C. (2006) Quantitative trait loci for thermotolerance phenotypes in *Drosophila melanogaster*. *Heredity* 96: 232–242.
- Mori, N., and Kimura, M.T. (2008) Selection for rapid and slow recovery from chill- and heat-coma in *Drosophila melanogaster*. *Biological Journal of the Linnean Society* 95: 72–80.
- Norry, F.M., Gomez, F.H. and Loeschcke, V. (2007) Knockdown resistance to heat stress and slow recovery from chill coma are genetically associated in a quantitative trait locus region of chromosome 2 in *Drosophila melanogaster*. *Molecular Ecology* 16: 3274–3284.
- Norry F.M., Scannapieco, A.C., Sambucetti, P., Bertoli, C.I. and Loeschcke, V. (2008) QTL for the thermotolerance effect of heat hardening, knockdown resistance to heat and chill-coma recovery in an intercontinental set of recombinant inbred lines of *Drosophila melanogaster*. *Molecular Ecology* 17: 4570–4581.
- O'Donnell, M.J. (2009) Too much of a good thing: how insects cope with excess ions or toxins in the diet. *The Journal of Experimental Biology* 212: 363–372.
- Overgaard, J., Kristensen, T.N., Mitchell, K.A. and Hoffmann, A.A. (2011) Thermal tolerance in widespread and tropical *Drosophila* species: does phenotypic plasticity increase with latitude? *American Naturalist* 178: S80–S96.
- Phillips, J.E. (1964) Rectal absorption in the desert locust, *Schistocerca gregaria* Forskål II sodium, potassium and chloride. *The Journal of Experimental Biology* 41: 39–67.
- Phillips, J.E., Meredith, J., Spring, J. and Chamberlin, M. (1982) Control of ion reabsorption in locust rectum: Implications for fluid transport. *Journal of Experimental Zoology* 222: 297–308.
- Qi, Z. Whitt, I., Mehta, A., Jin, J., Zhao, M., Harris, R.C., Fogo, A.B. and Breyer, M.D. (2004) Serial determination of glomerular filtration rate in conscious mice using FITC-inulin clearance. *American Journal of Physiology-Renal* 286: F590–F596.
- R Core Development Team (2011) R: a language and environment for statistical computing. R Foundation for Statistical Computing, Vienna, Austria. URL: <http://www.R-project.org>

- Ransberry, V.E., MacMillan, H.A. and Sinclair, B.J. (2011) The relationship between chill-coma onset and recovery at the extremes of the thermal window of *Drosophila melanogaster*. *Physiological and Biochemical Zoology* 84: 553-559.
- Rodgers, C.I., Armstrong, G.A.B. and Robertson, R.M. (2010) Coma in response to environmental stress in the locust: A model for cortical spreading depression. *Journal of Insect Physiology* 56: 980-990.
- Sisodia, S. and Singh, B.N. (2010) Influence of developmental temperature on cold shock and chill coma recovery in *Drosophila ananassae*: acclimation and latitudinal variations among Indian populations. *Journal of Thermal Biology* 35: 117-124.
- Telonis-Scott, M., Hallas, R., McKechnie, S.W., Wee, C.W. and Hoffmann, A.A. (2009) Selection for cold resistance alters gene transcript levels in *Drosophila melanogaster*. *Journal of Insect Physiology* 55: 549-555.
- Terblanche, J.S., Clusella-Trullas, S., Deere, J.A. and Chown, S.L. (2008) Thermal tolerance in a south-east African population of the tsetse fly *Glossina pallidipes* (Diptera, Glossinidae): implications for forecasting climate change impacts. *Journal of Insect Physiology* 54: 114-127.
- Williams, C.M., Pelini, S.L., Hellmann, J.J. and Sinclair, B.J. (2010) Intra-individual variation allows an explicit test of the hygric hypothesis for discontinuous gas exchange in insects. *Biology Letters* 6: 274-277.
- Wood, D.W. (1963) Sodium and potassium composition of some insect skeletal muscle fibres in relation to their membrane potentials. *Comparative Biochemistry and Physiology* 9: 151-159.
- Ziegler, A., Grospietsch, T., Carefoot, T.H., Danko, J.P., Zimmer, M., Zerbst-Boroffka, I. and Pennings, S.C. (2000) Hemolymph ion composition and volume changes in the supralittoral isopod *Ligia pallasii* Brandt, during molt. *Journal of Comparative Physiology B* 170: 329-336.

Chapter 6

6 Phenotypic plasticity and evolution of *Drosophila* cold tolerance are associated with modulation of Na⁺ and K⁺ homeostasis

This work is being prepared for submission to *Proceedings of the National Academy of Sciences of the United States of America*.

6.1 Introduction

Predictions of how a changing global climate will impact organismal fitness require a clear understanding of the mechanisms that set critical thermal limits to performance (Chown and Gaston, 2008; Gaston et al., 2009; Pörtner and Farrell, 2008). Temperature has a profound effect on the physiology of ectothermic organisms as it directly impacts rates of essential enzymatic processes. Because the poleward range limits of terrestrial insects are largely determined by the frequency and severity of low winter temperatures, increased winter survival may facilitate range expansion of insect populations (Bale and Hayward, 2010; Battisti et al., 2005; Crozier, 2003). The physiological mechanisms underlying the insect critical thermal minimum (CT_{min}), and the mechanisms that drive variation in this trait, however, are currently unclear.

Upon crossing their CT_{min}, insects enter chill-coma, a state of paralysis induced by failure of the neuromuscular system (Hosler et al., 2000; Mellanby, 1939; Staszak and Mutchmor, 1973). Chill-coma recovery time (CCR) is the time required for an insect to recover the ability stand following removal from the cold (David et al., 1998). Both CT_{min} and CCR are commonly used as measures of insect cold tolerance (David et al., 2003; Gibert and Huey, 2001; Hazell et al., 2010; Kelty and Lee, 2001; Macdonald et al., 2004; Terblanche et al., 2008). For chill-susceptible insects, prolonged exposure to low temperatures causes an accumulation of non-freezing cold-induced injuries (chilling injury; Chapter 4; Baust and Rojas, 1985; Košťál et al., 2004; Košťál et al., 2006).

There is both inter- and intraspecific variation in the CT_{min} , CCR and susceptibility to chilling injury, and many insects have substantial capacity for phenotypic plasticity of cold tolerance (e.g. David et al., 2003; Gibert and Huey, 2001; Klok and Chown, 2003; Košťál et al., 2004). For example, the CT_{min} of sub-Antarctic weevils is lower in species or populations that originate from cooler climates than those from warmer climates, and acclimation to low temperatures decreases the CT_{min} (Klok and Chown, 2003). Crickets (*Acheta domesticus*, Orthoptera: Gryllidae) acclimated to 25 °C exhibit faster CCR than crickets acclimated to 33 °C (Lachenicht et al., 2010), and cold acclimation protects tropical cockroaches (*Nauphoeta cinerea*, Blattodea: Blaberidae) from developing chilling injury during chronic low-temperature exposure (Košťál et al., 2006).

6.1.1 *Drosophila* as a model for variation in cold tolerance

Variation in cold tolerance is particularly well-described in species of the genus *Drosophila* (Hoffmann et al., 2003). Most *Drosophila* species are chill-susceptible, and die from chilling injury accumulated at temperatures above their freezing point (Chen and Walker, 1994; Nyamukondiwa et al., 2011; Strachan et al., 2011). *Drosophila* species vary in cold tolerance, however, and closely-related species tend to share similar critical thermal minima (Kellermann et al., 2012; Kristensen et al., 2011). *Drosophila* species from high latitudes are also consistently more cold-tolerant (have lower CT_{min} and faster CCR) than species from low latitudes (Gibert et al., 2001; Hori and Kimura, 1998; Kellermann et al., 2012; Kimura, 2004; Overgaard et al., 2011). This among-species variation in cold tolerance persists under common laboratory-rearing conditions, implying that this phenotype is related to an underlying genetic component (Ayrinhac et al., 2004; Hallas et al., 2002; Kellermann et al., 2009). Genomic and transcriptomic screens of *D. melanogaster* have identified some candidate genes (e.g. *Fst*, *Smp-30*, and *desat2*) associated with variation in the CT_{min} and CCR (Clowers et al., 2010; Mackay et al., 2012; Morgan and Mackay, 2006; Telonis-Scott et al., 2009). However, these candidates have proven difficult to interpret because their physiological roles in cold tolerance remain poorly understood.

Drosophila melanogaster has substantial capacity for phenotypic plasticity of CT_{min} and CCR, which can be induced by exposing flies to natural variations in temperature,

altering static rearing or acclimation temperatures, or by applying rapid cold hardening (RCH) treatments (Gibert and Huey, 2001; Kelty, 2007; Kelty and Lee, 2001; Nyamukondiwa et al., 2011; Overgaard and Sørensen, 2008; Ransberry et al., 2011; Sinclair and Roberts, 2005). For example, Ransberry et al. (2011) induced 13°C of variation in CT_{min} of *D. melanogaster* through a combination of rearing and adult acclimation temperatures. This phenotypic plasticity within one species exceeds the range in CT_{min} (c. 12 °C) of 95 *Drosophila* species from diverse climates raised at a common temperature of 20 °C (Kellermann et al., 2012).

The wide variation in both basal and inducible cold tolerance across the genus makes *Drosophila* an ideal system for the study of mechanisms underlying this variation. Among *Drosophila* species, variation in lower lethal temperature constrains the capacity for cold tolerance plasticity (Nyamukondiwa et al., 2011), which suggests that some physiological mechanisms of cold tolerance plasticity and adaptation may be shared in this genus.

6.1.2 Disruption of ion homeostasis underlies CT_{min} and chilling injury in insects

A loss of ion balance appears to underlie the insect CT_{min} and chilling injury during low temperature exposure (Chapters 3 and 4). Insect muscles are bathed in hemolymph, and muscle cell potentials are dependent on both intra- and extracellular concentrations of ions, particularly K^+ (Hoyle, 1953). Although muscle resting potential is depolarized by chilling in many insects, including *Drosophila* (Esch, 1988; Goller and Esch, 1990; Hosler et al., 2000), muscle cell ion concentrations do not change during cold exposure in cockroaches, field crickets, or locusts (Chapter 4; Findsen et al., 2013; Košťál et al., 2006).

The patterns of ion balance disruption that cause loss of muscle resting potential are best-understood in the fall field cricket (*Gryllus pennsylvanicus*, Orthoptera: Gryllidae; Chapter 4). Cold exposure causes a net leak of Na^+ ions down their concentration gradient from the hemolymph to the gut lumen (Chapter 4). Since hemolymph water balance is dependent on Na^+ , water follows Na^+ into the gut. This loss of hemolymph

volume elevates the concentration of K^+ remaining in the hemocoel, depolarizing the membrane potentials of the muscle cells bathed in the fluid. Recovery from chill-coma appears to require that crickets actively re-establish Na^+ gradients in the hemolymph, which restores hemolymph volume and reduces hemolymph $[K^+]$ (Chapter 5). The loss of neuronal excitability at low temperatures has also been associated with increased $[K^+]$ concentration in the neuronal extracellular space (Armstrong et al., 2012; Rodgers et al., 2010; Staszak and Mutchmor, 1973).

Thus, failure and recovery of extracellular Na^+ and K^+ homeostasis appear to underlie initiation of, and recovery from, chill coma in *G. pennsylvanicus*. It remains unclear, however, whether this mechanism extends to other insects, and which ionoregulatory mechanisms are responsible for such failure at the cell and tissue levels.

6.1.3 Na^+/K^+ -ATPase plays important ionoregulatory roles in *Drosophila*

Unequal distributions of Na^+ and K^+ ions across biological membranes and epithelia are generated and maintained by Na^+/K^+ -ATPase in most metazoans (EC: 3.6.3.9). The Na^+/K^+ -ATPase of insects is composed of two transmembrane subunits: a catalytic α -subunit, and a β -subunit that assists in proper folding of the α -subunit, targeting of the protein to the plasma membrane, and K^+ transport (Emery et al., 1998). At the cellular level, Na^+/K^+ -ATPase in the cell membrane consumes ATP to pump $3Na^+$ out of the cell cytoplasm and $2K^+$ in during each reaction cycle, maintaining high intracellular $[K^+]$ and low intracellular $[Na^+]$ (Emery et al., 1998). At the whole-organism level, Na^+/K^+ -ATPase maintains high extracellular $[Na^+]$, and in insects Na^+ balance is primarily maintained by the renal system, which is composed of the Malpighian tubules and hindgut.

There is high Na^+/K^+ -ATPase activity in the renal system of *Drosophila*; mRNA for the α -subunit is enriched 7.9-fold in the Malpighian tubules and 5.3-fold in the hindgut (relative to whole-body) of *D. melanogaster* (Chintapalli et al., 2007). Na^+/K^+ -ATPase in the basolateral membrane of Malpighian tubule principal cells is important in determining rates of Na^+ and water secretion into the gut (Beyenbach et al., 2010; Linton

and O'Donnell, 1999). Inhibition of the enzyme elevates $[\text{Na}^+]$ of the secreted fluid by as much as 73 %, and increases the fluid secretion rate by c. 15 % in *D. melanogaster* (Linton and O'Donnell, 1999). High Na^+/K^+ -ATPase activity in the basal membrane of the hindgut is responsible for transporting Na^+ back into the hemolymph of the mosquito (*Aedes aegypti*, Diptera: Culicidae; Patrick et al., 2006), and net Na^+ is transported into the hemolymph in the larval hindgut of *D. melanogaster* (Naikkhwah and O'Donnell, 2012). Thus, Na^+/K^+ -ATPase in the *Drosophila* renal system appears to maintain high $[\text{Na}^+]$ in the hemolymph and limit Na^+ loss to the gut lumen and feces.

6.1.4 Does modulation of ion homeostasis underlie variation in insect cold tolerance?

If ion-balance disruption causes chill-coma, differences in the ability to maintain ion homeostasis may underlie phenotypic plasticity and among-species variation of insect cold tolerance. Indeed, spring field crickets (*Gryllus veletis*), maintain both hemolymph volume and low hemolymph $[\text{K}^+]$, and do not acquire chilling injury even after exposure to 0 °C for 5 days, a treatment that causes nearly 100 % mortality in the closely-related *G. pennsylvanicus* (Coello Alvarado, 2012). Cold-acclimated *G. pennsylvanicus* also mitigate the loss of Na^+ into their gut during cold exposure, and both cold-acclimated crickets and firebugs (*Pyrrhocoris apterus*, Hemiptera: Pyrrhocoridae) maintain low hemolymph $[\text{K}^+]$ at low temperatures, which delays the onset of chilling injury during cold exposure (Košťál et al., 2004; Coello Alvarado, 2012). Thus, variation in both basal and inducible cold tolerance in insects appears to be related to changes in basal hemolymph ion concentrations and the ability to maintain ion balance in the cold.

Because of the important role that Na^+/K^+ -ATPase plays in cellular and organismal ion balance, temperature-induced failure of this enzyme has been hypothesized to be a principal cause of ionic and osmotic failure of insects in the cold (see 2.4.3.1; Goller and Esch, 1990; Hosler et al., 2000; Košťál et al., 2006; Sinclair et al., 2004; Zachariassen et al., 2004). At the cellular level, failure of Na^+/K^+ -ATPase is likely to lead to a loss of transmembrane Na^+ and K^+ gradients. At the tissue level, failure of Na^+/K^+ -ATPase in the renal system of *Drosophila* may cause rates of ion leak across the gut epithelia to exceed the capacity of active ion transport.

The negative effects of low temperature on net ion transport rates may be mitigated by reduced ion permeability, increased ion pump activity across all temperatures (e.g. though increased abundance of transporters), or through modifications to the relationship between enzyme activity and temperature (e.g. a shift in the temperature-activity relationship or decreased enzyme thermal sensitivity, see 2.4.3.1). Changes to the relationship between enzyme activity and temperature are common in cold-adapted organisms. For example, the temperature-activity relationship of α -amylase extracted from psychrophilic organisms is cold-shifted relative to mesothermic or thermophilic organisms. This change in the temperature-activity relationship permits maintenance of relatively high enzyme activity at low temperatures, and is mediated by reduced structural stability of the enzyme (e.g. Cipolla et al., 2012). Reductions in thermal sensitivity are also associated with adaptation of enzymes to low temperatures (Dong and Somero, 2009; Galarza-Muñoz et al., 2011; Garrett and Rosenthal, 2012; Somero, 2004). For example, polar and temperate octopus species have Na^+/K^+ -ATPase α -subunits that differ in thermal sensitivity; the maximal rate of Na^+/K^+ -ATPase does not differ between polar and temperate octopi at temperatures greater than 25 °C, but that of polar octopi is 4-fold higher at 10 °C (Galarza-Muñoz et al., 2011).

6.1.5 Objectives and hypotheses

Maintenance of low hemolymph $[\text{K}^+]$ is likely to facilitate a lower CT_{min} and protection from chilling injury. Because the cold-induced increase in hemolymph $[\text{K}^+]$ is driven by a migration of water, and hemolymph water balance is, typically, dependent on hemolymph $[\text{Na}^+]$ (Chapter 4; Wyatt, 1961), hemolymph Na^+ balance may be modified to improve cold tolerance in one of two ways. First, high Na^+/K^+ -ATPase activity in cold tolerant insects may allow them to maintain high hemolymph $[\text{Na}^+]$ as temperature decreases, thereby maintaining hemolymph volume and low hemolymph $[\text{K}^+]$. Alternatively, cold-tolerant insects may partly decouple water and Na^+ balance (i.e. maintain other osmolytes in the place of Na^+), and maintain low $[\text{Na}^+]$ in the hemolymph through low Na^+/K^+ -ATPase activity. Such a reduction in hemolymph $[\text{Na}^+]$ would reduce the transepithelial gradient for Na^+ across the gut wall, and thus reduce the chemiosmotic force that drives Na^+ and water leak in the cold. Regardless of how resting Na^+/K^+ -ATPase activity is

related to cold tolerance, shifts in the temperature-activity relationship or reductions to the thermal sensitivity of Na^+/K^+ -ATPase (as observed in octopi; Galarza-Muñoz et al., 2011) may underlie improvements in the ability to maintain ion balance during low temperature exposure, and thereby contribute to cold tolerance variation in insects.

In this chapter, I test the hypothesis that modulation of hemolymph $[\text{K}^+]$ and $[\text{Na}^+]$ are means by which insects acquire cold tolerance. To test this hypothesis, I use both phenotypic plasticity of cold tolerance induced in *Drosophila melanogaster* through thermal acclimation, and variation in basal cold tolerance among 24 species of the *Drosophila* genus reared under common conditions. I predict that:

1. Acute cold exposure will lead to an increase in hemolymph $[\text{K}^+]$ in *D. melanogaster*.
2. Cold tolerant flies maintain low hemolymph $[\text{K}^+]$, at rest and at low temperatures.
3. Variation in cold tolerance is associated with basal Na^+ and water balance in the hemolymph in one of two ways: Either (i) more cold-tolerant flies maintain steep $[\text{Na}^+]$ gradients and have high Na^+/K^+ -ATPase activity, or (ii) hemolymph Na^+ and water balance are decoupled in cold-tolerant flies, which have low hemolymph $[\text{Na}^+]$ and low Na^+/K^+ -ATPase activity.
4. Cold-tolerant flies have Na^+/K^+ -ATPase with low thermal sensitivity and a cold-shifted temperature-activity relationship.

I compared resting hemolymph $[\text{Na}^+]$ and $[\text{K}^+]$ as well as maximal Na^+/K^+ -ATPase activity and temperature-activity relationships among *Drosophila* species and between warm- and cold acclimated *D. melanogaster*. Cold tolerance was associated with low Na^+/K^+ -ATPase activity, so to test the hypothesis that a reduction in activity is mediated by reduction in the abundance of Na^+/K^+ -ATPase, I compared transcript and protein abundance of the α - and β -subunits of Na^+/K^+ -ATPase between warm- and cold-acclimated *D. melanogaster*.

6.2 Materials and methods

6.2.1 Animal origins and husbandry

I included a total of 24 species from the genus *Drosophila* in this study. *D. melanogaster* and *D. hydei* were field-collected in London Ontario in 2007 (Marshall and Sinclair, 2010; Strachan et al., 2011), and *D. mauritiana* and *D. nepalensis* were donated by Dr. Amanda Moehring (Western University) and Dr. Ravi Parkash (Maharshi Dayanand University, India), respectively. Individuals of the remaining species were obtained from stock centers. Complete information on stock origins is presented in Appendix C (Table C.1).

All species were maintained on the same banana, barley malt and yeast-based diet medium (Nyamukondiwa et al., 2011) except that the diet of four cactophilic species (*D. mojavensis*, *D. obscura*, *D. persimilis* and *D. pseudoobscura*) was supplemented with 2.1 g L⁻¹ *Opuntia ficus-indicta* powder (OroVerde Export, Morelos, Mexico; Markow and O'Grady, 2005). With the exception of cold-acclimated *D. melanogaster* (described below) all flies were maintained at a constant 21.5 ± 0.5 °C and at 50 ± 5 % relative humidity with a 13:11 h (L:D) light cycle. Flies were raised from egg to adult in 35 mL vials containing ~10 mL of food medium. Adult flies from each generation were transferred to 3.7 L plastic containers for mass breeding and egg collection during which adult flies were provided with a Petri dish of food topped with yeast paste (1.5:1 active yeast:water). The food plate was replaced after 24 h and eggs were collected from this second plate after 14 h at a density of 75 per vial (Marshall and Sinclair, 2010).

Newly-eclosed adult *Drosophila* were transferred, without anaesthesia, to fresh 35 mL vials containing food medium. Following transfer, adults were returned to 21.5 °C for five days before use in experiments. For the *D. melanogaster* acclimation experiments, virgin males were collected under light CO₂ anaesthesia (<10 min) on the day of their emergence, divided randomly into two groups which were placed at either 21.5 °C (warm-acclimated), or at 6 ± 0.5 °C conditions (cold-acclimated) for five days to acclimate (and to control for anaesthesia effects on cold tolerance; Nilson et al., 2006).

Not all experimental groups were used in all of the experiments described below. A summary of the experimental design used is presented in Figure 6.1.

6.2.2 Measurement of CT_{\min}

The critical thermal minima of warm- and cold-acclimated *D. melanogaster* were obtained from a previous study of the same laboratory population (Ransberry et al., 2011). The CT_{\min} of each *Drosophila* species was measured as in Ransberry et al. (2011). Briefly, adult flies were transferred into a custom-built, temperature-controlled 150×25 cm glass column containing aluminum baffles to which the flies cling (similar to the design of Huey et al., 1992). The temperature of the column was controlled by circulating a ethylene glycol:water (1:1) mixture through the column jacket from a refrigerated circulating bath (model 1157P, VWR International, Radnor, PA, USA). The temperature inside the column was independently monitored by four type-T thermocouples (two at both the top and bottom of the column) and a TC-08 interface connected to a computer running Picolog v5.20.1 (Pico Technology, St. Neots, UK). Adult flies were released into the column where they clung to the baffles. Following 15 min at 21 °C, column temperature was decreased at 0.1 °C min^{-1} to -10 °C. Flies lost their ability to cling to the baffles when the temperature inside the column reached their CT_{\min} , and fell to the bottom of the column where they were collected in a 50 mL plastic tube containing soapy water. At 1 °C increments the tube was changed and flies within each tube were filtered from the water and frozen in liquid nitrogen vapour before being sorted according to sex and counted.

6.2.3 Hemolymph ion concentration

Hemolymph ion concentrations were measured in 4-8 (K^+) and 3-5 (Na^+) adult flies from each *Drosophila* species, and 14-16 (Na^+) and 15-21 (K^+) flies in each acclimation group per treatment (control and 6 h at 0 °C) for *D. melanogaster* males. The *D. kanekoi* and *D. algonquin* lines were lost before hemolymph ion concentrations were measured, and so were not included in this analysis.

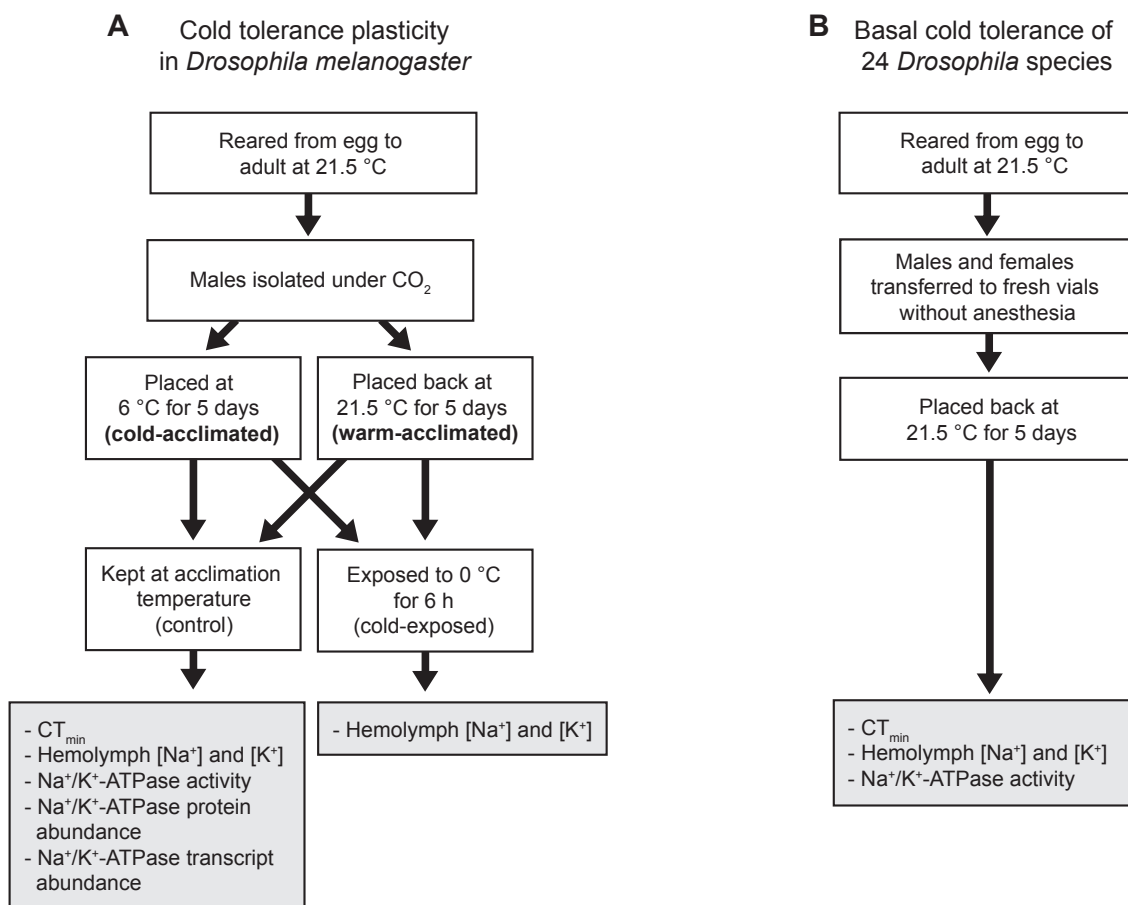

Figure 6.1. Flow-chart of experimental design. Phenotypic plasticity of cold tolerance (A) was induced in virgin *Drosophila melanogaster* males by thermal acclimation. Variation in basal cold tolerance among *Drosophila* species (B; both males and females) was compared following rearing and adult maturation under common temperature (21.5 °C) conditions. The experiments completed on each experimental group are shown in grey boxes. CT_{min} estimates of warm- and cold-acclimated *D. melanogaster* were obtained from a previous study on the same laboratory population (Ransberry et al., 2011).

Hemolymph Na^+ and K^+ concentrations were measured in all *Drosophila* at rearing temperature (21.5 ± 1 °C). For the cold exposure, *D. melanogaster* were transferred to microcentrifuge tubes and submerged in an ice-water slurry (0 °C) for 6 h. Flies that received a cold exposure were sampled immediately following removal from the cold to 21.5 °C. Hemolymph was extruded from adult *Drosophila* by antennal amputation. An individual fly was moved to the end of a 10 μL pipette tip by applying air pressure from behind (See Supplementary Methods, Appendix C). Once the fly was restrained by the inner diameter of the tip, a razor was used to cut the pipette tip and expose the antennae. A single antenna was amputated at its base and air pressure applied, yielding a clear ~ 100 nL hemolymph droplet. The pipette tip with the fly and droplet attached was removed from the apparatus and the droplet was placed under hydrated paraffin oil in less than 5 s for immediate measurement of ion concentration. The time from removal of a fly from its acclimation temperature or from 0 °C to measurement of ion concentration in the hemolymph was less than 2 min.

Hemolymph Na^+ and K^+ activities were measured using an ion-selective microelectrode (ISME) technique following Jonusaite et al. (2011). Microelectrodes were constructed by pulling borosilicate glass capillaries (TW-150-4, World Precision Instruments (WPI), Sarasota, FL, USA) to a tip diameter of ~ 5 μm using a P-97 Flaming Brown micropipette puller (Sutter Instruments Co., Novato, USA). Pulled micropipettes were silanized at 300 °C with N,N-dimethyltrimethylsilylamine vapour for 1 h and backfilled with 100 mM KCl or NaCl. Microelectrodes were then front-filled with ionophore cocktails for either K^+ (K^+ ionophore II, Sigma Aldrich, St. Louis, MO, USA) or Na^+ (Na^+ ionophore X; Messerli et al., 2008) and dipped in a solution of polyvinylchloride (Sigma Aldrich) in tetrahydrofuran (Sigma Aldrich) to prevent loss of the ionophore. A borosilicate glass (IB200F-4, WPI) reference electrode backfilled with 0.5 M KCl was used to complete the circuit. Voltage was recorded using a ML 165 pH amplifier and PowerLab 4/30 data acquisition system connected to a computer running LabChart 6 software (AD Instruments, Colorado Springs, CO, USA).

Hemolymph ISME voltages were converted to ion concentration by reference to calibration solutions of known concentration using equation (1):

$$[h] = [c] \times 10^{\frac{\Delta V}{S}} \quad (1)$$

where $[h]$ is the active ion concentration in the hemolymph, $[c]$ is the concentration in one of the calibration solutions, ΔV is the voltage difference between the calibration solution and hemolymph, and S is the slope of the voltage response to a tenfold concentration difference in calibration solutions.

6.2.4 Na⁺/K⁺-ATPase activity

6.2.4.1 Na⁺/K⁺-ATPase activity and thermal sensitivity

To quantify maximal Na⁺/K⁺-ATPase activity, whole flies (~80 mg of pooled males and females; 20-80 flies, depending on species) were transferred to 1.7 mL microcentrifuge tubes without anesthesia, snap frozen in liquid nitrogen vapour, and stored at -80 °C. Na⁺/K⁺-ATPase activity was measured in 6 biological replicates of each temperature acclimation group of *D. melanogaster* and 3-6 biological replicates of each species used for the interspecific analysis. Frozen *Drosophila* were weighed to obtain pooled fresh mass in pre-weighed 2 mL microcentrifuge tubes before being homogenized on ice in 1 mL of homogenization buffer (25 mM imidazole, 0.2 % w/v Na⁺-deoxycholate, 10 mM β-mercaptoethanol, 2 mM EDTA, pH 7.5) with a Tissue-Tearor (Biospec Products, Bartlesville, OK, USA) using four 10 s bursts each followed by 20 s rests on ice. Homogenized samples were sonicated (Virsonic 100; VirTis, Gardiner, NY, USA) following the same timing of bursts and rests and centrifuged at 7000 × *g* for 5 min at 4 °C. Size-exclusion filtration columns, which permit the passage of proteins larger than approximately 50 kD, were prepared by plugging the tip of a 3 mL plastic syringe barrel with glass wool and adding 3 mL of Sephadex G-50 (GE Healthcare, Waukesha, WI, USA). Columns were stored at 4 °C for a maximum of two weeks before use, and were conditioned by eight additions of 300 μL of homogenization buffer and 1 min centrifugations (500 × *g*). A conditioned column was placed into a clean 5 mL plastic test tube, a 300-μL aliquot of supernatant derived from the homogenate was added to the column, and the column within the tube was centrifuged at 500 × *g* for 1 min to draw the sample through the column and into the tube (McMullen and Storey, 2008).

Maximum reaction rates (V_{\max}) of Na^+/K^+ -ATPase were quantified using an NADH-linked spectrophotometric assay (Schoner et al., 1967) in 1 mL cuvettes. The absorbance of NADH at 340 nm was recorded using a Cary 100 Bio spectrophotometer with a Cary Peltier-effect Temperature Controller (Agilent Technologies, Santa Clara, CA, USA) connected to a computer running WinUV Thermal Application v3.0 (Agilent Technologies). Filtered fly homogenates were diluted 7-fold in homogenization buffer immediately before a 20 μL aliquot was added to the cuvette containing 880 μL of assay buffer initially at 23 $^{\circ}\text{C}$. The reaction was initiated by the addition of 100 μL of a 50 mM ATP solution. Final conditions for the assay were: 70 mM imidazole (pH 7.5), 140 mM NaCl, 30 mM KCl, 7 mM MgCl_2 , 4 mM phosphoenolpyruvic acid, 300 μM NADH, 5 mM ATP 50 U mL^{-1} pyruvate kinase (EC: 2.7.1.40), and 50 U mL^{-1} lactate dehydrogenase (EC: 1.1.1.27). Four replicate assays of each sample were performed, two of which contained 1 mM ouabain (a specific inhibitor of Na^+/K^+ -ATPase).

To measure the thermal sensitivity of V_{\max} , I developed a thermally-dynamic assay in which the temperature of each sample was ramped downwards from 23 $^{\circ}\text{C}$ to 3 $^{\circ}\text{C}$ at $-0.15\text{ }^{\circ}\text{C min}^{-1}$ while enzyme activity was being assayed. This approach yielded a complete data set of enzyme V_{\max} across the temperature range from each technical replicate. The assay began following sample equilibration to 23 $^{\circ}\text{C}$ for 10 min. The temperature of a dummy sample inside a cuvette was monitored by a ceramic temperature probe (Agilent Technologies) interfaced with the spectrophotometer, and was also recorded using a type-T thermocouple and TC-08 interface connected to the same computer running Picolog v5.20.1 (Pico Technology, St. Neots, UK).

For each replicate, rates of change in absorbance (OD min^{-1}) were smoothed using a 15-point sliding window in LoggerPro (v3.8.4, Vernier Software Inc., Beaverton, OR, USA). Ouabain-sensitive activity (the change in absorbance due to Na^+/K^+ -ATPase activity) was determined for each pair of samples by subtracting rates of absorbance change in the sample containing ouabain from that of the uninhibited sample across the temperature range (see Supplementary Methods, Appendix C). Enzyme activity was expressed relative to total soluble protein determined in a separate aliquot of the sample supernatant (prior to column purification) as measured by Bradford assay (1976).

6.2.4.2 Na⁺/K⁺-ATPase protein abundance

The abundance of the Na⁺/K⁺-ATPase α - and β -subunit proteins in *D. melanogaster* were quantified by western blot in 7 (α) and 4-5 (β) biological replicates of each acclimation group. Twenty adult male flies were homogenized using a glass dounce homogenizer in 1 mL of buffer (160 mM Tris-HCl, 0.2 % w/v Na⁺-deoxycholate, pH 6.8) with protease inhibitors (1 mM PMSF, 5 μ g mL⁻¹ aprotinin and leupeptin) added immediately before sample preparation. Homogenized samples were transferred to 1.7 mL microcentrifuge tubes and centrifuged at 7000 \times g and 4 °C for 5 min. A 200 μ L aliquot was reserved for protein quantification using a BCA protein assay kit (Thermo Scientific, Waltham, MA, USA), and a second 200 μ L aliquot was added to an equal volume of a 2 \times concentrated loading buffer to yield final loading conditions (4 M urea, 4 % w/v SDS, 4 % v/v β -mercaptoethanol, 4 % v/v glycerol, 0.005 % w/v bromophenol blue).

Samples in loading buffer were loaded (15 μ g soluble protein) on SDS-polyacrylamide gels (10 % w/v resolving gel, 5 % w/v stacking gel) in a SE600 electrophoresis unit (Hoefer Inc., Holliston, MA, USA). Loaded samples were separated by electrophoresis (120 V for ~2.5 h) in running buffer (25 mM Tris-base, 192 mM glycine, 0.3 % w/v SDS, pH 8.6) and resolved proteins were wet transferred at 4 °C to polyvinylidene fluoride (PVDF) membranes (Biotrace, Pall Corp., Port Washington, NY, USA) at 15 V overnight (Newington et al., 2011). The following morning membranes were soaked in blocking buffer (20 mM Tris-base, 150 mM NaCl, 0.05% v/v Tween 20, 3 % w/v BSA, 1.5 % w/v dry blotting milk, pH 7.5) for 1h at 22 °C. Blocked membranes were washed (3 \times 5 min) in wash buffer (20 mM Tris-base, 150 mM NaCl, 0.05 % v/v Tween 20, pH 7.5). Membranes were incubated in primary antibody buffer (20 mM Tris-base, 150 mM NaCl, 0.05 % v/v Tween 20, 3 % w/v BSA, 0.05 % w/v sodium azide, pH 7.5) for 1 h at 22 °C. The primary antibody buffer contained mouse antibodies targeting either the α - (a5; 1:500; antigen species: chicken; Developmental Studies Hybridoma Bank (DSHB), Iowa City, IA, USA) or β -subunit (nrv5F7; 1:50; antigen species: *Drosophila*; DSHB) of Na⁺/K⁺-ATPase (Lebovitz et al., 1989; Sun and Salvaterra, 1995). Probed membranes were then washed (3 \times 5 min, as above), incubated in blocking buffer containing goat anti-mouse IgG horseradish peroxidase conjugate secondary antibody (1:10000; BioRad

Laboratories Inc., Hercules, CA, USA), and washed again. Following 1 min incubation in SuperSignal West Pico chemiluminescent substrate (Thermo Fisher Scientific Inc., Rockford, IL, USA), images of immunoblots were produced using a ChemiDoc digital imaging system (BioRad; Newington et al., 2011).

After probing, membranes were stained for total protein as a loading control following the methods of Welinder and Ekblad (2011). Membranes were washed (2×5 min), stained with 0.1 % Coomassie R-350 in methanol:water (1:1) for 1 min, and destained with acetic acid:ethanol:water (1:5:4) for 20 min. Following destaining, the membranes were air-dried and scanned at 600 dpi on a flatbed scanner.

6.2.4.3 Na^+/K^+ -ATPase mRNA abundance

The abundance of transcripts coding for Na^+/K^+ -ATPase subunits were quantified using high-throughput mRNA sequencing (RNA-seq). Frozen warm- and cold-acclimated male *D. melanogaster* (5 biological replicates per acclimation temperature, each containing 25 flies) were homogenized by mortar and pestle over liquid nitrogen in 1 mL of TRIzol reagent (Life Technologies Corp., Carlsbad, CA, USA). Homogenized samples were centrifuged at $12,000 \times g$ for 5 min at 4 °C and the top 200 μL (lipids) discarded. Total RNA extraction from samples was completed using a RNeasy lipid tissue mini kit (Qiagen, Hilden, Germany). Chloroform (200 μL) was added to the tubes, samples were shaken for 15 s, and left at 22 °C for 3 min. Samples were centrifuged at $12,000 \times g$ for 15 min at 4 °C, the upper (aqueous) phase transferred to a new tube with 1 volume of 70 % ethanol, and vortexed (30 s). A 700 μL aliquot of the sample was centrifuged ($8000 \times g$ for 15 s at 22 °C) through an RNeasy Mini spin column (Qiagen) in a 2 mL collection tube. The effluent was discarded and the sample (bound to the column) was washed with 700 μL of RW1 buffer (Qiagen), and $2 \times 500 \mu\text{L}$ of RPE buffer (Qiagen) using the same centrifuge settings. The column was placed into a new collection tube and RNase-free water (50 μL) was centrifuged through the column ($8000 \times g$ for 1 min at 22 °C) twice to release the RNA from the column.

Total mRNA was purified from RNA, and cDNA libraries were prepared using a TruSeq Stranded mRNA preparation kit (Illumina Inc., San Diego, CA, USA) following the

TruSeq RNA sample prep v2 protocol (Illumina). Briefly, mRNA was purified by poly-A selection using magnetic beads bound to poly-T oligo-nucleotides and chemically fragmented. Fragmented mRNA was reverse-transcribed into single stranded cDNA by reverse transcriptase and the RNA on the opposite strand was replaced with DNA to yield double stranded (ds) cDNA. Overhangs at the 3' and 5' ends of ds cDNA were cleaved and repaired by exonuclease and DNA polymerase, respectively. ds cDNA was tagged with Illumina adapter sequences (Illumina Inc., San Diego, CA, USA) and tagged sequences were selectively amplified by PCR using primers for the adapter sequences. cDNA libraries were sequenced (50 bp single-end reads) using a HiSeq 2000 (Illumina) at the Huntsman Cancer Institute (University of Utah).

6.2.5 Data analysis

All data analysis was completed in R v.2.15 (R Core Team, 2012). Values reported in the text for descriptive purposes are mean \pm sem unless otherwise stated.

Accelerated failure time models were fitted to the numbers of flies that fell from the temperature-controlled column at each temperature using the `survreg()` function of the survival package (Therneau and Grambsch, 2000). The best-fitting models retained species as a factor but excluded sex, and had a logistic error distribution for CT_{min} . For each species, the temperature at which 80 % of the flies had fallen from the column was extracted from the model using the `aggregate()` function for use in further analyses, and is henceforth referred to as CT_{min} (Ransberry et al., 2011).

Hemolymph ion concentrations were compared among treatments and acclimation groups of *D. melanogaster* by ANOVA with group and treatment as factors, followed by Tukey's HSD. The relationships between hemolymph ion concentration and the CT_{min} among *Drosophila* species were analyzed by model II linear regression using the `lmodel2` package (Legendre, 2013).

Using the SSlogis() function, self-starting logistic models were fitted to Na⁺/K⁺-ATPase V_{max} estimates (nmol ATP consumed min⁻¹ mg) across the range of measurement temperatures:

$$R = \frac{Max}{1+e^{(IP-T)/Ts}} \quad (2)$$

where T is temperature and R is the empirically-determined rate of ATP turnover per minute at that temperature, Max is the model-derived logistic asymptote, IP is the model-derived inflection point of the curve, and Ts is model-derived sensitivity of $Rate$ to temperature (Figure 6.2). The IP parameter is a measure of the position of the temperature-activity curve on the temperature axis, and can be used to detect cold- or warm-shifts in the enzyme activity-temperature relationship. The Ts parameter is a measure of enzyme thermal sensitivity.

Logistic functions provided a good fit to the data (Figure 6.2). As Max in this equation represents the enzyme reaction rate at $T=\infty$, and enzymes denature at high temperatures, this parameter is not biologically-relevant and was not used in further analyses. Estimates of Ts and IP were obtained for each sample from the fitted models, and rates across the range of temperatures (3-21.5 °C) were extracted from models using the predict() function (which allowed me to standardize all rates to common temperature intervals). Values of V_{max} for Na⁺/K⁺-ATPase that were obtained through this method were similar to those determined by running the assay at static temperatures instead of using a temperature ramp (see supplementary methods, Appendix C). Reaction rates (V_{max}) at 21.5 °C, Ts and IP of Na⁺/K⁺-ATPase, were compared between warm- and cold-acclimated *D. melanogaster* using t-tests. Among *Drosophila* species, the relationships between these variables and the CT_{min} were tested using model II linear regression. *D. arawakana* was excluded from the Na⁺/K⁺-ATPase dataset because of low sample size ($n=1$).

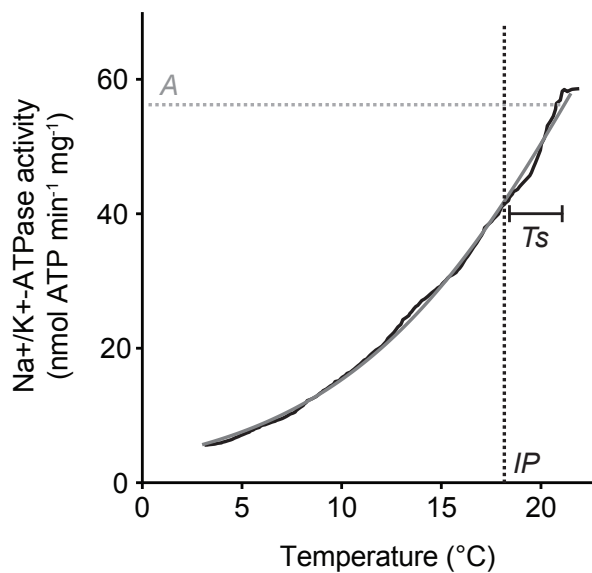

Figure 6.2. Example of a logistic model (solid grey line) fitted to Na^+/K^+ -ATPase activity of warm-acclimated *Drosophila melanogaster* (solid black line). The temperature at which the curve stops accelerating and begins decelerating (the inflection point; *IP*; dotted black line) as well as the thermal sensitivity (*T_s*) of Na^+/K^+ -ATPase were extracted from the model equation (Equation 2). Sodium pump activity across the range of temperatures (including at the rearing temperature, 21.5 °C; *A*: dotted grey line) were extracted from model predictions and used to compare activity between acclimation groups (*D. melanogaster*) and among *Drosophila* species.

Densitometric quantification of immunoblots and total protein images were completed by measuring band and total lane intensity in Image J (Schneider et al., 2012). The abundance of each Na^+/K^+ -ATPase subunit was compared between warm- and cold-acclimated *D. melanogaster* using an ANCOVA, with total protein abundance included as a covariate.

Transcriptome data manipulation and statistical analyses were completed in Galaxy (Goecks et al., 2010) following the analysis workflow of Trapnell et al. (2012). Illumina adapter sequences were clipped from reads using FastQ Clipper (part of the FastX Toolkit), and clipped reads were aligned to the genome of *D. melanogaster* (Ensembl build 5.25) using TopHat (v.2.0.8; Trapnell et al., 2009), with alignment limited to known splice junctions. Cufflinks was used to assemble and count transcript reads for each sample and Cuffmerge was used to merge assembled transcripts for all biological replicates into a single reference transcriptome (v.2.0.2; Trapnell et al., 2010).

Na^+/K^+ -ATPase subunit transcript expression was compared between warm- and cold-acclimated flies using Cuffdiff (Trapnell et al., 2013). Cuffdiff generates relative transcript expression, expressed as fragments per kilobase of exon per million mapped reads (FPKM), test statistics for differential expression of each gene, and *P*-values adjusted for false-discovery (P_{adj} ; Benjamini and Hochberg, 1995).

6.2.6 Phylogenetically-independent contrasts

Physiological trait variation across a clade is expected to reflect phylogenetic history, as closely related species are likely to be more physiologically similar than distantly related species (Garland et al., 2005). To confirm that relationships between cold tolerance and physiological traits identified are not a consequence of phylogeny, I used phylogenetically-independent contrasts (PICs), which control for phylogeny in statistical analyses (Garland et al., 1992). The PICs were calculated using a phylogeny constructed by combining two recently published phylogenies of *Drosophila* (Figure 6.3A). A recent comprehensive phylogeny of the family Drosophilidae (Van der Linde et al., 2010) contains all but four of the species used in this study, and was used as the base for my tree. Extraneous species were trimmed from the Van der Linde et al. (2010) tree, and the

four additional species (*D. borealis*, *D. kanekoi*, *D. nepalensis*, and *D. triauraria*) were added from a second phylogeny (Strachan et al., 2011) with branch lengths standardized to the rest of the tree using the ratio of nearest-neighbor distance (Kellermann et al., 2012). Node ages were standardized using a semi-parametric method for use in statistical analyses (Sanderson, 2002) using the `chronopl()` function of the `ape` package (Paradis et al., 2004).

Phylogenetically-independent contrasts (PICs) of species trait means were generated in R using the `pic()` function in the `ape` package. Tests of relationships between the CT_{\min} and physiological traits while controlling for phylogeny were conducted using linear regressions of PICs forced through the origin with the `lmorigin()` function (Garland et al., 1992; Legendre and Desdevises, 2009). Significant relationships that become non-significant after accounting for the phylogeny can be explained by the phylogenetic history of the genus, while those that remain significant are independent of phylogeny. *P*-values of PIC models are presented in the figures where appropriate and plots of all PICs can be found in Appendix C (Figure C.4). Species traits were also tested for phylogenetic signal – a measure of the tendency for related species to have similar trait values - by the K-statistic (Blomberg et al., 2003) using the `phylosig()` function in the `R` `phytools` package (Revell, 2012).

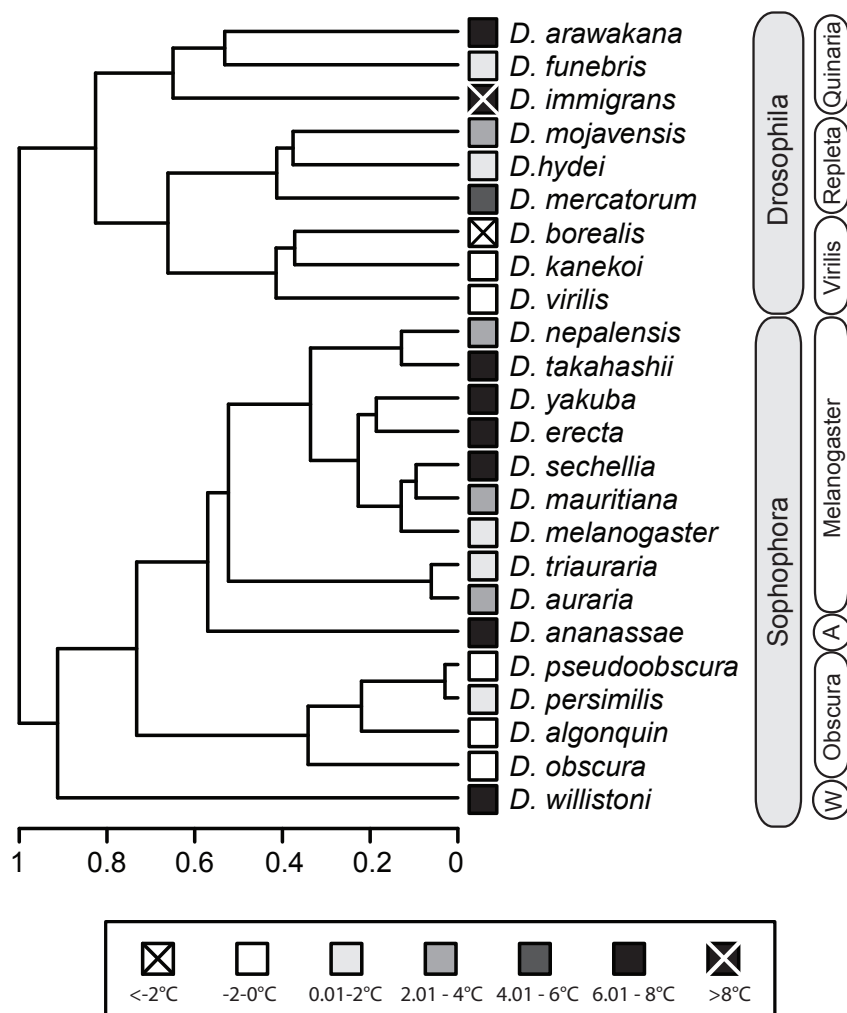

Figure 6.3. Phylogeny of the genus *Drosophila* and among-species variation in the CT_{min} . Branch lengths represent relative time since divergence from a common ancestor. Shaded boxes represent the CT_{min} (temperature at which 80 % of flies are knocked down). Vertical labels denote subgenera (grey) and groups (open). A: Ananassae group, W: Willistoni group.

6.3 Results

6.3.1 Critical thermal minima

Cold acclimation significantly reduced the CT_{min} of *Drosophila melanogaster* from 3.4 ± 0.2 °C to 0.9 ± 0.1 °C (Ransberry et al., 2011). For the interspecific comparisons a mean of 206 (range: 78 - 695) flies were used to determine the CT_{min} of each sex in each *Drosophila* species (Appendix C, Figure C.3). The CT_{min} varied among species from -2.9 ± 0.1 °C (*D. borealis*) to 8.2 ± 0.1 °C (*D. immigrans*; mean \pm sem; Figure 6.3; Appendix C, Table C.2, Figure C.3), and had significant phylogenetic signal ($K=0.77$, $P=0.002$).

6.3.2 Hemolymph ion concentration

Cold-acclimated *Drosophila melanogaster* males had significantly lower hemolymph $[Na^+]$ than warm-acclimated flies ($F_{1,56}=14.1$, $P<0.001$), but exposure to 0 °C for 6 h had no effect on hemolymph $[Na^+]$ in either acclimation group ($F_{1,56}=0.4$, $P=0.544$; Figure 6.4A). Both acclimation temperature ($F_{1,72}=20.2$, $P<0.001$) and cold exposure ($F_{1,72}=7.6$, $P=0.007$) significantly affected hemolymph $[K^+]$, with no interactions ($F_{1,72}=3.0$, $P=0.090$). Under control conditions (at their respective acclimation temperatures), hemolymph $[K^+]$ did not differ significantly between warm- and cold-acclimated *D. melanogaster* (Tukey HSD; $P=0.197$; Figure 6.4B). Exposure to 0 °C increased hemolymph $[K^+]$ from 28.4 ± 2.4 mM to 40.4 ± 3.7 mM in warm-acclimated flies, (Tukey HSD; $P=0.011$), but did not significantly alter hemolymph $[K^+]$ in cold-acclimated flies (Tukey HSD; $P=0.441$; Figure 6.4B).

Hemolymph $[Na^+]$ of *Drosophila* species ranged from 47.6 ± 4.7 mM (*D. immigrans*) to 154.1 ± 6.7 mM (*D. sechellia*; Appendix C, Table C.2), and did not have significant phylogenetic signal ($K=0.43$, $P=0.125$; Figure 6.5A). Hemolymph $[K^+]$ did have significant phylogenetic signal ($K=0.70$, $P=0.014$), and ranged from 16.8 ± 1.4 mM (*D. auraria*) to 37.6 ± 2.8 mM (*D. willistoni*; Figure 6.5B). When *D. immigrans* was included in the regression of $[Na^+]$ against the CT_{min} the relationship was non-significant ($r_{1,83}=0.183$, $P=0.094$). Upon removal of *D. immigrans*, however, there was a significant positive relationship between hemolymph $[Na^+]$ and the CT_{min} ($r_{1,80}=0.350$, $P=0.001$).

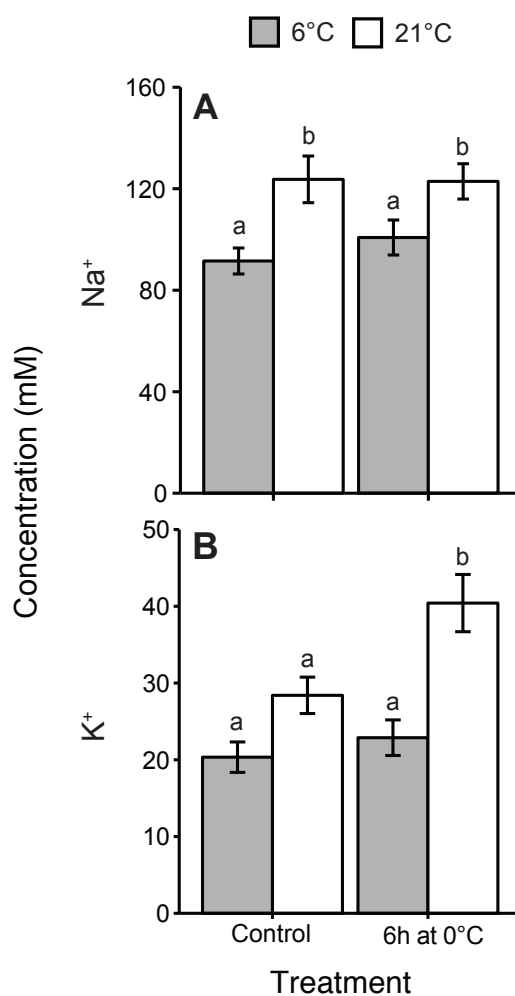

Figure 6.4. Hemolymph Na⁺ (A) and K⁺ (B) concentrations of cold-acclimated (grey bars) and warm-acclimated (open bars) male *Drosophila melanogaster* at their acclimation temperature (Control) and following 6 h at 0 °C. Bars within a panel that share a letter do not significantly differ. $n=14-16$ (Na⁺) and $n=15-21$ (K⁺) per acclimation group per treatment.

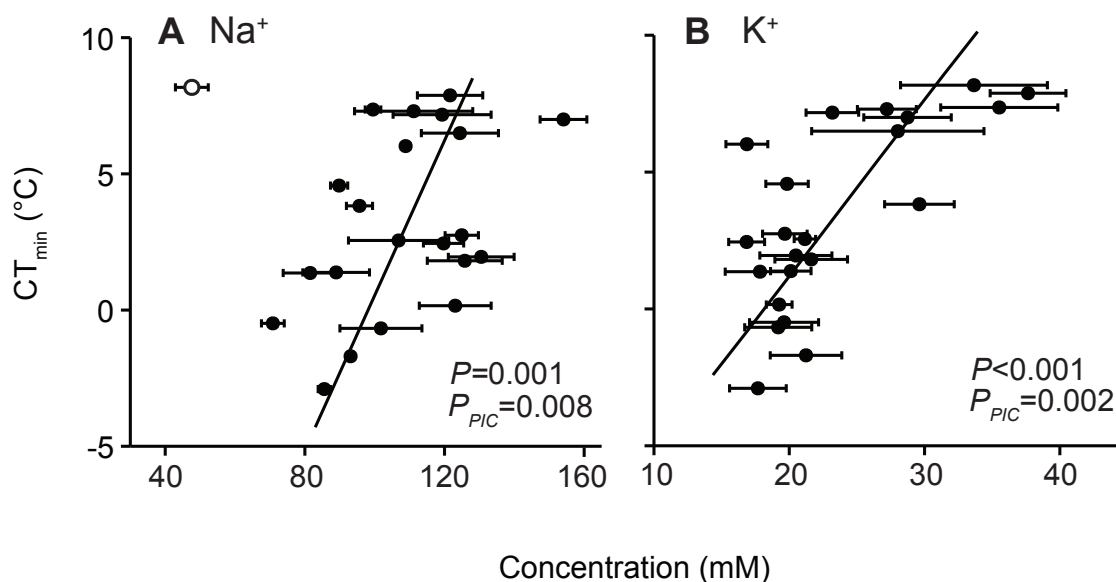

Figure 6.5. Hemolymph concentrations of Na^+ (A) and K^+ (B) of species of the genus *Drosophila* in relation to the CT_{min} . Lines denote a significant linear relationship between ion concentration and the CT_{min} among species. *Drosophila immigrans* (open circle) had remarkably low hemolymph [Na^+] and was omitted from the regression (see text for details). P : P -value from raw data regression, P_{PIC} : P -value from a regression using phylogenetically-independent contrasts forced through the origin. $n=2-5$ (K^+) and $n=1-3$ (Na^+). Y-axis (CT_{min}) error bars (sem) are obscured by the symbols.

Similarly, there was a significant relationship between hemolymph $[K^+]$ and the CT_{min} among species ($r_{1,127}=0.491$, $P<0.001$; Figure 6.5B). Following PIC regression to control for phylogeny, the significant relationships between ion concentration and the CT_{min} both remained significant ($[Na^+]$: $F_{1,19}=8.5$, $P=0.008$, $[K^+]$: $F_{1,20}=12.3$, $P=0.002$).

6.3.3 Na^+/K^+ -ATPase activity

Na^+/K^+ -ATPase activity, the temperature-activity inflection point (IP), and thermal sensitivity (Ts) of activity were extracted from logistic models (Figure 6.2). Na^+/K^+ -ATPase activity at 21.5 °C of cold-acclimated *D. melanogaster* (37.6 ± 2.8 nmol ATP $min^{-1} mg^{-1}$) was significantly lower than of warm-acclimated flies (76.8 ± 10.9 nmol ATP $min^{-1} mg^{-1}$; $t_8=4.4$, $P<0.001$, Figure 6.6A). At their acclimation temperature (6 °C), the Na^+/K^+ -ATPase activity of cold-acclimated flies was 5.0 ± 0.5 nmol ATP $min^{-1} mg^{-1}$, 54.3 % lower than the Na^+/K^+ -ATPase activity of warm acclimated flies at the same temperature, and 93.5 % lower than the warm acclimated flies at 21.5 °C. The inflection point ($t_9=1.8$, $P=0.101$) and thermal sensitivity ($t_9=1.2$, $P=0.261$) of Na^+/K^+ -ATPase activity did not significantly differ between warm- and cold-acclimated *D. melanogaster* (Figure 6.6B).

Among *Drosophila* species, Na^+/K^+ -ATPase activity at 21.5 °C ranged from 14.4 ± 1.7 nmol ATP $min^{-1} mg^{-1}$ (*D. funebris*) to 75.4 ± 13.3 nmol ATP $min^{-1} mg^{-1}$ (*D. yakuba*; Appendix C, Table C.2). There was significant phylogenetic signal in Na^+/K^+ -ATPase activity at 21.5 °C ($K=1.20$, $P=0.001$), and a significant positive relationship between activity and the CT_{min} among species ($r_{1,90}=0.315$, $P=0.002$; Figure 6.7A). *D. immigrans* somewhat diverged from the otherwise evident relationship between enzyme activity and CT_{min} (as with hemolymph $[Na^+]$, section 6.3.2), and was removed from the analysis (Figure 6.7A). Inclusion of *D. immigrans*, however, did not affect the statistical significance of the relationship between Na^+/K^+ -ATPase activity and the CT_{min} ($r_{1,95}=0.224$, $P=0.028$).

Following PIC regression to control for phylogeny, there was no significant relationship between Na^+/K^+ -ATPase activity at 21.5 °C and the CT_{min} among species ($F_{1,20}=0.1$, $P=0.711$). There was no significant relationship between the Na^+/K^+ -ATPase inflection

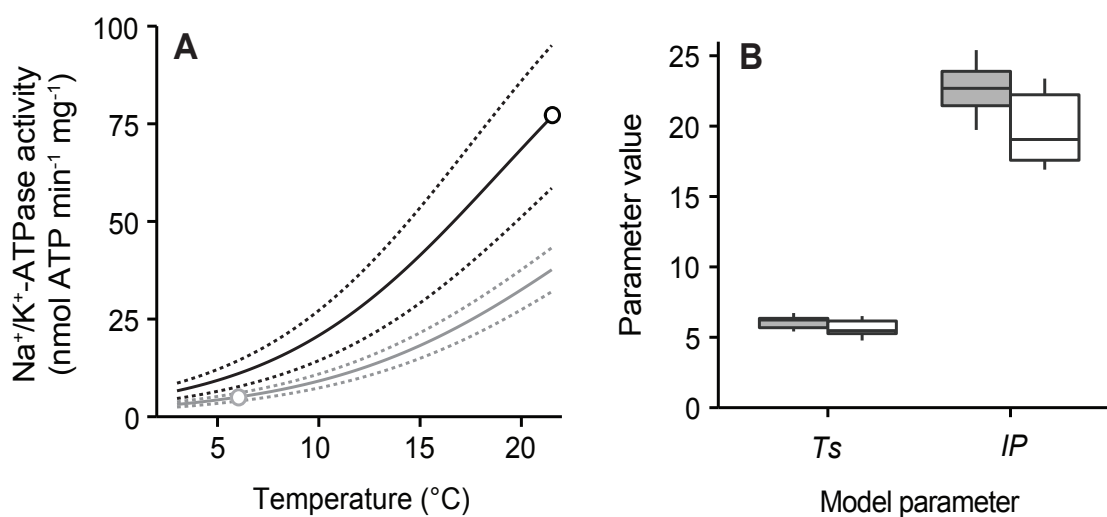

Figure 6.6. Na⁺/K⁺-ATPase activity (A), and inflection point (*IP*) and thermal sensitivity (*T_s*; B) of *Drosophila melanogaster*. (A) Sodium pump activity of warm-acclimated (21.5 °C, black) and cold-acclimated (6 °C, grey) *D. melanogaster*. Solid lines and dotted lines represent the mean and 95 % CI, respectively. Open circles denote mean activity at the acclimation temperature. Cold-acclimated *D. melanogaster* had significantly lower Na⁺/K⁺-ATPase activity at 21.5 °C than warm-acclimated flies (B) Boxplots of *IP* and *T_s* values of warm-acclimated (open) and cold-acclimated (grey) *D. melanogaster*. Vertical lines denote the range and horizontal lines denote the median and quartiles. There was no significant effect of acclimation temperature on *IP* or *T_s*. *n*=6 (80 mg) samples per acclimation group (see text for details).

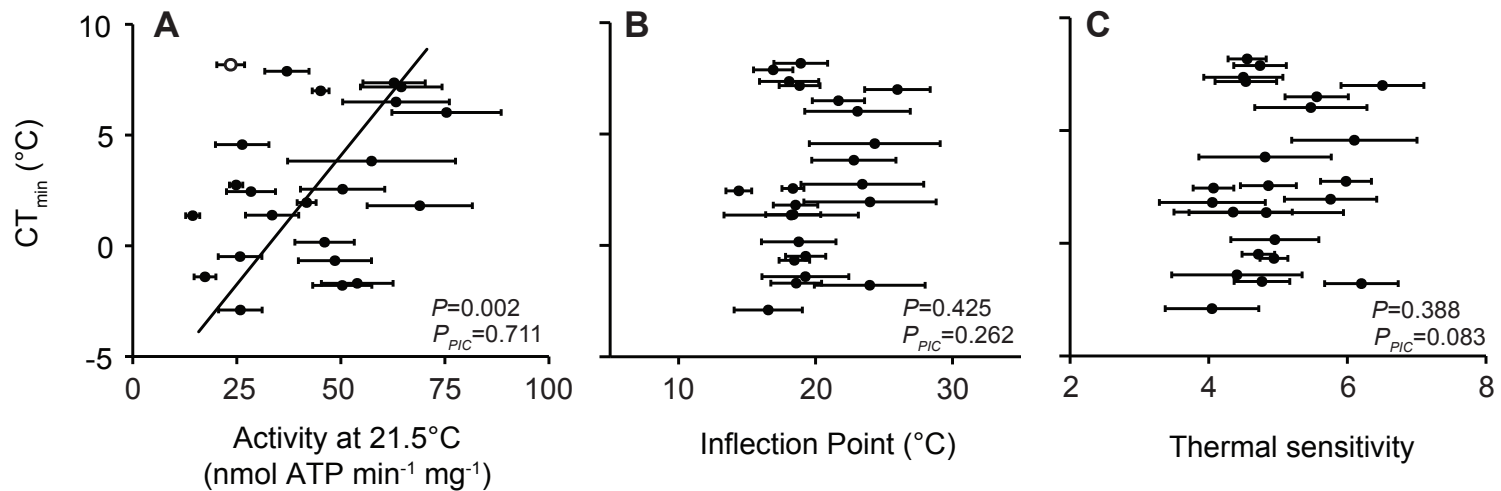

Figure 6.7. Mean (\pm sem) Na⁺/K⁺-ATPase activity at 21.5 °C (A) inflection point (B) and thermal sensitivity (C) of species of the genus *Drosophila* in relation to the CT_{min} . Solid line denotes a significant relationship between activity at 21.5 °C and cold tolerance. *Drosophila immigrans* (open circle) had low Na⁺/K⁺-ATPase activity and was omitted from the analysis of activity at 21.5 °C. Relationships between the CT_{min} and the inflection point and thermal sensitivity of Na⁺/K⁺-ATPase among *Drosophila* species were marginally non-significant. P_{PIC} : P -value from a regression of phylogenetically-independent contrasts forced through the origin. There was a near-significant positive relationship between phylogenetically-independent contrasts of Na⁺/K⁺-ATPase thermal sensitivity and the CT_{min} . $n=3-6$ (80 mg) samples per species. CT_{min} error bars (sem) are obscured by the symbols.

point and the CT_{\min} ($r_{1,95}=0.081$, $P=0.425$; Figure 6.7B), nor was there a significant relationship between the PICs of these traits ($F_{1,21}=1.3$, $P=0.262$). Similarly, there was no significant relationship between the thermal sensitivity of Na^+/K^+ -ATPase and the CT_{\min} , ($r_{1,95}=0.089$, $P=0.388$; Figure 6.7C), but there was a marginally non-significant positive relationship between thermal sensitivity of Na^+/K^+ -ATPase and CT_{\min} following PIC regression ($F_{1,21}=3.3$, $P=0.083$). Neither the Na^+/K^+ -ATPase inflection point ($K=0.17$, $P=0.841$) or thermal sensitivity ($K=0.20$, $P=0.727$) had significant phylogenetic signal.

6.3.4 Na^+/K^+ -ATPase transcript and protein abundance

Immunoblots for Na^+/K^+ -ATPase of *D. melanogaster* revealed bands at the expected molecular weights for both the α (c. 110 kD) and β (37-42 kD) subunits (Figure 6.8A). The relative protein abundance of the α -subunit ($F_{2,11}=0.9$, $P=0.379$) and β -subunit (β : $F_{2,6}=0.2$, $P=0.835$) did not differ between warm- and cold-acclimated *D. melanogaster* (Figure 6.8B).

Transcript abundance of the primary Na^+/K^+ -ATPase α -subunit gene (*Atpa*) did not differ between acclimation groups ($t_9=1.0$, $P_{adj}=0.723$; Figure 6.8C). *Drosophila melanogaster* has three genes that code for the Na^+/K^+ -ATPase β -subunit. Cold-acclimated flies had significantly higher expression of *nrv2* mRNA than warm-acclimated flies ($t_9=3.7$, $P_{adj}=0.003$), but warm- and cold-acclimated flies did not differ in the relative abundance of either *nrv1* ($t_9=0.7$, $P_{adj}=0.897$) or *nrv3* ($t_9=1.9$, $P_{adj}=0.257$; Figure 6.8C).

Figure 6.8. Na⁺/K⁺-ATPase protein (A, B) and mRNA (C) abundance in warm- and cold-acclimated *Drosophila melanogaster*. (A) Representative immunoblots of the α (~110 kD) and β (37-42 kD) subunits of Na⁺/K⁺-ATPase of *D. melanogaster* acclimated to 6 °C and 21.5 °C. (B) Mean \pm sem relative protein abundance as determined from immunoblot lane intensity. Samples (15 μ g soluble protein) and signal expressed as relative abundance corrected to total protein staining (see 6.2.8). n=7 (α) and 4-5 (β) per acclimation group. Warm- and cold- acclimated flies did not differ significantly in the abundance of either Na⁺/K⁺-ATPase subunit. (C) Na⁺/K⁺-ATPase subunit transcript expression, expressed as fragments per kilobase of transcript per million mapped reads (FPKM \pm 95 % CI). Asterisk denotes a significant difference in relative expression of *nrv2* between acclimation groups. n=5 biological replicates of 25 flies per acclimation group.

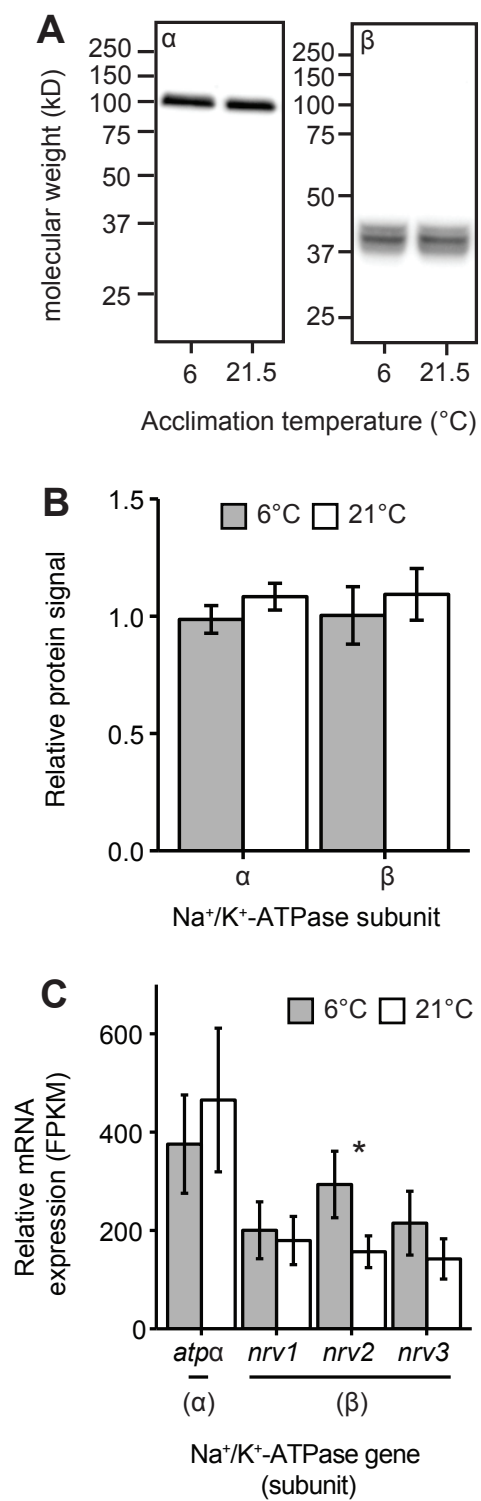

6.4 Discussion

In the present study, I hypothesized that modulation of hemolymph $[K^+]$ and $[Na^+]$ are means by which insects acquire cold tolerance. I predicted that (1) cold exposure causes an increase in hemolymph $[K^+]$ in *Drosophila*, as in other insects, and (2) cold tolerant flies have low resting hemolymph $[K^+]$ and maintain low hemolymph $[K^+]$ at low temperatures. I also predicted that cold tolerance may be acquired either through maintenance of high hemolymph $[Na^+]$ and high Na^+/K^+ -ATPase activity or through low hemolymph $[Na^+]$ and low Na^+/K^+ -ATPase activity. I predicted that (4) cold tolerant *Drosophila* have low thermal sensitivity of Na^+/K^+ -ATPase. Lastly, I hypothesized that changes in Na^+/K^+ -ATPase activity are partly mediated through changes in the abundance of Na^+/K^+ -ATPase proteins and transcripts.

6.4.1 Cold acclimation mitigates the effects of low temperature on hemolymph $[K^+]$

Exposure to low temperatures caused an increase in hemolymph $[K^+]$ in warm-acclimated *D. melanogaster* (Figure 6.4B). Cold exposure also causes an increase in hemolymph $[K^+]$ in chill- susceptible cockroaches (Košťál et al., 2006), fall field crickets (Chapters 4 and 5), locusts (Findsen et al., 2013), and firebugs (Košťál et al., 2004). The repeated observation that hemolymph $[K^+]$ increases during cold exposure in members of Orthoptera, Hemiptera and Diptera suggests that a loss of $[K^+]$ balance is a common consequence of cold exposure among chill-susceptible insects. Because muscle resting potential is dependent on extracellular $[K^+]$ (Hoyle, 1953), high concentrations of K^+ in the hemolymph are likely to depolarize cell membranes, prevent neuromuscular signal transmission and lead to chilling injury. This suggests that maintenance of $[K^+]$ is critical to the survival and fitness of cold-tolerant insects (Chapter 5; Košťál et al., 2006).

Cold-acclimated *D. melanogaster* maintained low extracellular $[K^+]$ during exposure to 0 °C (Figure 6.4), which suggests that cold acclimation allows *D. melanogaster* to maintain ion balance in the cold. Cold-acclimated crickets, tropical cockroaches, and adult firebugs all maintain low hemolymph $[K^+]$ during cold exposure (Coello Alvarado, 2012; Košťál et al., 2004; Košťál et al., 2006). In warm-acclimated fall field crickets, increased hemolymph $[K^+]$ during cold exposure is caused by migration of Na^+ and water

from the hemocoel to the gut that is driven by the transepithelial gradient for Na^+ (Chapter 4), and cold-acclimation is associated with improved maintenance of Na^+ balance across the gut wall (Coello Alvarado, 2012). Thus, like other insects, acclimation to low temperatures appears to improve the ability of *Drosophila* to maintain low hemolymph $[\text{K}^+]$ during cold exposure, which is likely driven by the ability to maintain water balance in the hemolymph.

6.4.2 Improvements in cold tolerance through modulation of resting hemolymph $[\text{Na}^+]$ and $[\text{K}^+]$

Improvements in cold tolerance of *Drosophila* are likely driven by the maintenance of low extracellular $[\text{Na}^+]$ and $[\text{K}^+]$. Cold-acclimated *D. melanogaster* maintained hemolymph $[\text{Na}^+]$ approximately 25 % lower than did warm-acclimated flies (Figure 6.4), and among *Drosophila* species there was a positive relationship between the CT_{\min} and concentrations of both Na^+ and K^+ at 21.5 °C (Figure 6.5). Cold-acclimated insects consistently tend to have more and less polarized muscle resting equilibrium potentials for Na^+ and K^+ , respectively, relative to warm-acclimated insects (Coello Alvarado, 2012; Košťál et al., 2004; Košťál et al., 2006), which suggests that increased K^+ gradients and decreased Na^+ gradients may be common mechanisms of acquired cold tolerance. Maintenance of low hemolymph $[\text{K}^+]$ in *Drosophila* likely hyperpolarizes resting K^+ equilibrium potentials and thereby reduces the effects of a reduction in hemolymph volume on muscle excitability. By contrast, a reduction in hemolymph Na^+ will reduce equilibrium potentials for Na^+ across cell membranes. Because all *Drosophila* used in this study were fed the same diet, and thus have similar gut contents, maintenance of low hemolymph $[\text{Na}^+]$ with cold-acclimation is also likely to reduce the transepithelial gradient for Na^+ across the gut wall, and thus reduce the chemiosmotic force that drives Na^+ and water leak in the cold.

The positive relationships between resting hemolymph ion concentrations and the CT_{\min} among *Drosophila* species remained when phylogeny was controlled for, meaning that reductions in resting ion concentrations are consistently associated with reductions in the CT_{\min} across the *Drosophila* phylogeny. There was significant phylogenetic signal in hemolymph $[\text{K}^+]$, as some species groups (such as the Obscura and Virilis groups;

Appendix C, Table C.2) had a tendency for low hemolymph $[K^+]$. Thus, selection for cold tolerance appears to be associated with selection for low hemolymph $[Na^+]$ and $[K^+]$ among *Drosophila*, and resting ion concentrations may play a role in determining basal cold tolerance.

6.4.3 Do cold tolerant insects decouple Na^+ and water balance?

Reduced hemolymph $[Na^+]$ is likely to reduce hemolymph osmotic pressure unless paired with increases in other osmolytes (Pierce et al., 1999; Wyatt, 1961). Cold-tolerant *Drosophila* could partially decouple Na^+ and water balance through increases in other organic or inorganic osmolytes. Adult Lepidoptera maintain very low hemolymph $[Na^+]$, in some cases low enough to reverse the muscle Na^+ gradient (Fitzgerald et al., 1996). To maintain hemolymph osmotic balance in the absence of Na^+ , Lepidoptera maintain high hemolymph concentrations of carbohydrates (Wyatt, 1961; Wyatt and Kalf, 1957). As a group, Lepidoptera appear to maintain muscle excitability to lower temperatures than members of Diptera and Hymenoptera (Goller and Esch, 1990), which have more “conventional” extracellular $[Na^+]$ (Natochin and Parnova, 1987). By contrast, some Coleoptera such as the freeze avoiding beetle *Rhagium inquisitor* (Cerambycidae) maintain high $[Mg^{2+}]$ in their hemolymph instead of Na^+ (Dissanayake and Zachariassen, 1980). Cold tolerant *Drosophila* may similarly maintain higher concentrations of molecules other than Na^+ in their hemolymph (such as other inorganic or organic ions, carbohydrates or free amino acids), which could assist in decoupling hemolymph water balance from Na^+ , and mitigate the effects of Na^+ leak on water balance in the cold. A variety of organic solutes act as cryoprotectants at high concentrations, and are of great importance to the overwintering success of freeze tolerant and freeze avoidant insects (Lee, 1991; Storey, 1997). Relatively modest accumulations of such compounds, which are unlikely to have cryoprotective effects, have been noted to occur following cold-acclimation and RCH treatments in insects (Lee et al., 1987; Overgaard et al., 2007). Many of these molecules, however, are also osmoprotectants (Sinclair et al.; Teets et al., 2013; Yancey, 2005). Thus, I propose that in chill-susceptible insects, relatively small accumulations of organic solutes, such as amino acids or carbohydrates, may maintain or

increase hemolymph osmotic pressure, and thereby permit a decoupling of Na^+ and water balance that promotes survival at low temperatures.

6.4.4 *Drosophila* cold tolerance is associated with low Na^+/K^+ -ATPase activity

Cold tolerance in *Drosophila* appears to be associated with low Na^+/K^+ -ATPase activity. Cold-acclimated *D. melanogaster* had depressed Na^+/K^+ -ATPase activity across all temperatures, such that the Na^+/K^+ -ATPase V_{max} was 93.5 % lower in cold-acclimated flies than warm-acclimated flies at their respective acclimation temperatures. The reduction of Na^+/K^+ -ATPase activity in cold-acclimated flies, in addition to the passive effects of temperature on enzyme activity, suggests that reduced activity of this enzyme is of particular importance to cold-acclimation (Figure 6.6A). Moreover, *Drosophila* species with low critical thermal minima had low Na^+/K^+ -ATPase activity at 21.5 °C, which suggests that low activity of this pump also contributes to basal cold tolerance (Figure 6.7A). Na^+/K^+ -ATPase plays important roles in the maintenance of high extracellular $[\text{Na}^+]$ in Diptera (Linton and O'Donnell, 1999; Naikkhwah and O'Donnell, 2012; Patrick et al., 2006), so low Na^+/K^+ -ATPase activity may be associated with the low hemolymph $[\text{Na}^+]$ observed in cold-tolerant *Drosophila*.

After accounting for phylogeny using PICs, there was no significant relationship between Na^+/K^+ -ATPase activity at 21.5 °C and the CT_{min} among *Drosophila* species (Appendix C, Figure C.4). This suggests that reductions in the CT_{min} are not consistently matched with reductions in Na^+/K^+ -ATPase activity across the *Drosophila* phylogeny, and that selection for cold tolerance may not act on resting Na^+/K^+ -ATPase activity. Low activity of this enzyme in cold tolerant species may be an exaptation (*sensu* Gould and Vrba, 1982), which was not selected for by low temperatures, but nonetheless contributes to cold tolerance. Na^+/K^+ -ATPase activity also had strong phylogenetic signal, indicating that closely related species share similar Na^+/K^+ -ATPase activity and that changes in activity occurred early in the radiation of the *Drosophila* genus. Such early divergence of Na^+/K^+ -ATPase activity among *Drosophila* groups would likely reduce the power of phylogenetically-independent statistics to detect a relationship between the CT_{min} and activity of the enzyme.

Modulation of Na⁺/K⁺-ATPase activity may occur at the transcriptional, translational, or post-translational levels (Bertorello et al., 1991; McDonough and Farley, 1993). In *D. melanogaster*, phenotypic plasticity of Na⁺/K⁺-ATPase activity does not appear to be caused by changing protein abundance, as there was no difference in abundance of either the α - or β -subunit of Na⁺/K⁺-ATPase between warm- and cold-acclimated flies (Figure 6.8A,B). There was no difference between warm- and cold-acclimated flies in the abundance of transcripts for the principal α -subunit gene (*Atpa*; Figure 6.8C). However, differences in enzyme activity between the warm- and cold-acclimated flies may occur through differences in the relative expression of *Atpa* splice variants; *D. melanogaster* has 11 known splice variants of *Atpa* (Marygold et al., 2013). Many of these splice variants differ only slightly in combinations of six 50-80 bp exons, and thus could not be reliably distinguished by the 50 bp RNA-seq reads. In the future, the contribution of *Atpa* splice variants to cold tolerance could be addressed in warm- and cold-acclimated *D. melanogaster*, by real-time PCR with isoform specific primers.

Cold acclimation increased the abundance of transcripts of *nrv2*, one of the three β -subunit genes (Figure 6.8C). This increase in *nrv2* transcript abundance may have induced a shift toward greater relative expression of Nrv2 protein with cold-acclimation. At the protein level, this difference between warm- and cold-acclimated flies would not have been detected, as the nrv5F7 primary antibody binds all three isoforms of the β -subunit (Sun and Salvaterra, 1995). Combinations of α - and β -subunits of Na⁺/K⁺-ATPase differ in their affinity for Na⁺ and K⁺, and β -subunit isoforms are expressed in *Drosophila* in a tissue-specific manner (Geering, 2008; Sun et al., 1998). Thus, increased *nrv2* expression or alternative splicing of *Atpa* in response to low temperatures may alter rates of Na⁺ and K⁺ transport *in vivo* and thereby modulate resting ion concentrations. Nrv2 is also an important component of septate junctions, basal membrane cell adhesions that limit paracellular solute diffusion in the blood-brain barrier, Malpighian tubules and hindgut (Beyenbach et al., 2010; Paul et al., 2007; Stork et al., 2008) so high *nrv2* expression following cold acclimation may indicate modulation of paracellular ion and water permeability. Modulation of Na⁺/K⁺-ATPase in *D. melanogaster* may also involve post-translational modification. McMullen and Storey (2008) described a winter

depression of Na^+/K^+ -ATPase activity in the freeze tolerant goldenrod gall fly (*Eurosta solidaginis*; Diptera, Tephritidae) that was mediated through reversible phosphorylation.

Contrary to the hypothesis that improvements in cold tolerance in *Drosophila* are driven by changes in the relationship between Na^+/K^+ -ATPase and temperature, warm- and cold-acclimated *D. melanogaster* did not differ in Na^+/K^+ -ATPase thermal sensitivity or inflection point (Figure 6.4B). Similarly, there was no relationship between the CT_{min} and either the thermal sensitivity or inflection point of Na^+/K^+ -ATPase among *Drosophila* species. There was a near-significant relationship between the PICs of Na^+/K^+ -ATPase thermal sensitivity and the CT_{min} (Figure 6.7C). Thus, improvements in cold tolerance across the *Drosophila* phylogeny may be associated with reductions in the thermal sensitivity of Na^+/K^+ -ATPase that are obscured by the phylogeny.

Rates of active ion transport may be modified by means other than modification of the thermal properties of Na^+/K^+ -ATPase proteins. Although the estimates of Na^+/K^+ -ATPase V_{max} obtained *in vitro* are reliable indicators of relative differences in Na^+/K^+ -ATPase activity, they may not approximate rates of ion transport *in vivo*, where local substrate (Na^+ , K^+ , and ATP) and co-factor (e.g. Mg^{2+}) concentrations and the immediate membrane environment would substantially impact ion transport rates. Adaptation and acclimation to low temperatures in *Drosophila* have been associated with decreased saturation of phospholipid fatty acids, which would increase membrane fluidity and maintain ion pump function at low temperatures (Ohtsu et al., 1993; Ohtsu et al., 1998; Overgaard et al., 2005; Overgaard et al., 2008; but see MacMillan et al., 2009). To examine the role of these influences on ion balance in the cold, comparative analyses of Na^+/K^+ -ATPase activity functioning within the membrane bilayer will be needed. Because the physiological mechanisms underlying insect ionoregulation are diverse (O'Donnell, 2008), the reductions in Na^+/K^+ -ATPase activity observed here may be one of several mechanisms of ionoregulation that contribute to cold-acclimation and adaptation. The roles, for example, of other ion-motive pumps (i.e. H^+ -ATPase and Ca^{2+} -ATPase) and exchangers, ion channels and aquaporins, paracellular routes of ion and water transport, and the hormones that regulate them remain to be explored in the context of insect cold tolerance.

6.4.5 Conclusion

Variation in *Drosophila* CT_{min} was associated with variation in hemolymph [Na⁺] and [K⁺] and whole-organism Na⁺/K⁺-ATPase activity. More cold-tolerant flies maintained lower hemolymph [Na⁺] both within and among *Drosophila* species, and reduced [Na⁺] may be mediated by reduced activity of Na⁺/K⁺-ATPase. Cold-tolerant *Drosophila* species also had low hemolymph [K⁺]. Among species, the relationships between hemolymph ion concentrations and the CT_{min} remain when phylogeny is incorporated into the analysis, suggesting that ion balance and cold tolerance are related for reasons independent of phylogeny. These changes to ion balance likely limit Na⁺ and water migration, and maintain low hemolymph [K⁺] in the cold, thereby improving low temperature performance. Thus, modulation of extracellular ion balance may be an important means by which *Drosophila* improve cold tolerance, and this leads to exciting hypotheses of the interdependent roles of ion transporters and channels in cold-acclimation and adaptation.

6.5 Literature cited

- Armstrong, G.A.B., Rodríguez, E.C. and Robertson, R.M. (2012). Cold hardening modulates K⁺ homeostasis in the brain of *Drosophila melanogaster* during chill coma. *Journal of Insect Physiology* 58: 1511–1516.
- Ayrinhac, A., Debat, V., Gibert, P., Kister, A.-G., Legout, H., Moreteau, B., Vergilino, R. and David, J.R. (2004). Cold adaptation in geographical populations of *Drosophila melanogaster* : Phenotypic plasticity is more important than genetic variability. *Functional Ecology* 18: 700–706.
- Bale, J.S. and Hayward, S.A.L. (2010). Insect overwintering in a changing climate. *The Journal of Experimental Biology* 213: 980–994.
- Battisti, A., Stastny, M., Netherer, S., Robinet, C., Schopf, A., Roques, A. and Larsson, S. (2005). Expansion of geographic range in the pine processionary moth caused by increased winter temperatures. *Ecological Applications* 15: 2084–2096.
- Baust, J. . and Rojas, R.R. (1985). Insect cold hardiness: Facts and fancy. *Journal of Insect Physiology* 31: 755–759.

- Benjamini, Y. and Hochberg, Y. (1995). Controlling the false discovery rate: a practical and powerful approach to multiple testing. *Journal of the Royal Statistical Society Series B* 57: 289–300.
- Bertorello, A.M., Aperia, A., Walaas, S.I., Nairn, A.C. and Greengard, P. (1991). Phosphorylation of the catalytic subunit of Na⁺,K⁺-ATPase inhibits the activity of the enzyme. *Proceedings of the National Academy of Sciences* 88: 11359–11362.
- Beyenbach, K.W., Skaer, H. and Dow, J.A.T. (2010). The developmental, molecular, and transport biology of Malpighian tubules. *Annual Review of Entomology* 55: 351–374.
- Blomberg, S.P., Garland, T. and Ives, A.R. (2003). Testing for phylogenetic signal in comparative data: behavioral traits are more labile. *Evolution* 57: 717–745.
- Bradford, M.M. (1976). A rapid and sensitive method for the quantification of microgram quantities of protein utilizing the principle of protein-dye binding. *Analytical Biochemistry* 72: 248–254.
- Chen, C.-P. and Walker, V.K. (1994). Cold-shock and chilling tolerance in *Drosophila*. *Journal of Insect Physiology* 40: 661–669.
- Chintapalli, V.R., Wang, J. and Dow, J.A.T. (2007). Using FlyAtlas to identify better *Drosophila melanogaster* models of human disease. *Nature Genetics* 39: 715–720.
- Chown, S.L. and Gaston, K.J. (2008). Macrophysiology for a changing world. *Proceedings of the Royal Society B* 275: 1469–1478.
- Cipolla, A., Delbrassine, F., Da Lage, J.-L. and Feller, G. (2012). Temperature adaptations in psychrophilic, mesophilic and thermophilic chloride-dependent alpha-amylases. *Biochimie* 94: 1943–1950.
- Clowers, K.J., Lyman, R.F., Mackay, T.F.C. and Morgan, T.J. (2010). Genetic variation in senescence marker protein-30 is associated with natural variation in cold tolerance in *Drosophila*. *Genetics Research* 92: 103–113.
- Coello Alvarado, L.E. (2012). Ion homeostasis and variation in low temperature performance in the fall and spring field crickets (Orthoptera: Gryllidae). University of Western Ontario - Electronic Thesis and Dissertation Repository. Paper 969. <http://ir.lib.uwo.ca/etd/969>.
- Crozier, L. (2003). Winter warming facilitates range expansion: cold tolerance of the butterfly *Atalopedes campestris*. *Oecologia* 135: 648–656.
- David, J.R., Gibert, P., Pla, E., Petavy, G., Karan, D. and Moreteau, B. (1998). Cold stress tolerance in *Drosophila*: analysis of chill coma recovery in *D. melanogaster*. *Journal of Thermal Biology* 23: 291–299.

- David, J.R., Gibert, P., Moreteau, B., Gilchrist, G.W. and Huey, R.B. (2003). The fly that came in from the cold: geographic variation of recovery time from low-temperature exposure in *Drosophila subobscura*. *Functional Ecology* 17: 425–430.
- Dissanayake, P. and Zachariassen, K.E. (1980). Effect of warm acclimation on the cationic concentrations in the extracellular and intracellular fluid of hibernating *Rhagium inquisitor* beetles. *Comparative Biochemistry and Physiology* 65A: 347–350.
- Dong, Y. and Somero, G.N. (2009). Temperature adaptation of cytosolic malate dehydrogenases of limpets (genus *Lottia*): differences in stability and function due to minor changes in sequence correlate with biogeographic and vertical distributions. *The Journal of Experimental Biology* 212: 169–177.
- Emery, A.M., Billingsley, P.F., Ready, P.D. and Djamgoz, M.B.A. (1998). Insect Na^+/K^+ -ATPase. *Journal of Insect Physiology* 44: 197–209.
- Esch, H. (1988). The effects of temperature on flight muscle potentials in honeybees and cuculiinid winter moths. *The Journal of Experimental Biology* 135: 109–117.
- Findsen, A., Andersen, J. L., Calderon, S. and Overgaard, J. (2013). Rapid cold hardening improves recovery of ion homeostasis and chill coma recovery time in the migratory locust, *Locusta migratoria*. *The Journal of Experimental Biology* 216: 1630–1637.
- Fitzgerald, E.M., Djamgoz, M.B.A. and Dunbar, S.J. (1996). Maintenance of the K^+ activity gradient in insect muscle compared in Diptera and Lepidoptera: contributions of metabolic and exchanger mechanisms. *The Journal of Experimental Biology* 199: 1857–1872.
- Galarza-Muñoz, G., Soto-Morales, S.I., Holmgren, M. and Rosenthal, J.J.C. (2011). Physiological adaptation of an Antarctic Na^+/K^+ -ATPase to the cold. *The Journal of Experimental Biology* 214: 2164–2174.
- Garland Jr., T., Harvey, P.H. and Ives, A.R. (1992). Procedures for the analysis of comparative data using phylogenetically independent contrasts. *Systematic Biology* 41: 18–32.
- Garland, T., Bennett, A. F. and Rezende, E. L. (2005). Phylogenetic approaches in comparative physiology. *The Journal of Experimental Biology* 208: 3015–3035.
- Garrett, S. and Rosenthal, J.J.C. (2012). RNA editing underlies temperature adaptation in K^+ channels from polar octopuses. *Science* 335: 848–851.
- Gaston, K.J., Chown, S.L., Calosi, P., Bernardo, J., Bilton, D.T., Clarke, A., Clusella-Trullas, S., Ghalambor, C.K., Konarzewski, M., Peck, L.S., et al. (2009). Macrophysiology: A conceptual reunification. *The American Naturalist* 174: 595–612.

- Geering, K. (2008). Functional roles of Na,K-ATPase subunits. *Current Opinion in Nephrology and Hypertension* 17, 526–532.
- Gibert, P. and Huey, R.B. (2001). Chill-coma temperature in *Drosophila*: Effects of developmental temperature, latitude, and phylogeny. *Physiological and Biochemical Zoology* 74: 429–434.
- Gibert, P., Moreteau, B., Pétavy, G., Karan, D. and David, J.R. (2001). Chill-coma tolerance, a major climatic adaptation among *Drosophila* species. *Evolution* 55: 1063–1068.
- Goecks, J., Nekrutenko, A., Taylor, J. and Team, T.G. (2010). Galaxy: a comprehensive approach for supporting accessible, reproducible, and transparent computational research in the life sciences. *Genome Biology* 11: R86.
- Goller, F. and Esch, H. (1990). Comparative study of chill-coma temperatures and muscle potentials in insect flight muscles. *The Journal of Experimental Biology* 150: 221–231.
- Gould, S.J. and Vrba, E.S. (1982). Exaptation—a missing term in the science of form. *Paleobiology* 8: 4–15.
- Hallas, R., Schiffer, M. and Hoffmann, A.A. (2002). Clinal variation in *Drosophila serrata* for stress resistance and body size. *Genetical Research* 79: 141–148.
- Hazell, S.P., Groutides, C., Neve, B.P., Blackburn, T.M. and Bale, J.S. (2010). A comparison of low temperature tolerance traits between closely related aphids from the tropics, temperate zone, and Arctic. *Journal of Insect Physiology* 56: 115–122.
- Hoffmann, A.A., Sørensen, J.G. and Loeschcke, V. (2003). Adaptation of *Drosophila* to temperature extremes: bringing together quantitative and molecular approaches. *Journal of Thermal Biology* 28: 175–216.
- Hori, Y. and Kimura, M.T. (1998). Relationship between cold stupor and cold tolerance in *Drosophila* (Diptera: Drosophilidae). *Environmental Entomology* 27: 1297–1302.
- Hosler, J.S., Burns, J.E. and Esch, H.E. (2000). Flight muscle resting potential and species-specific differences in chill-coma. *Journal of Insect Physiology* 46: 621–627.
- Hoyle, G. (1953). Potassium ions and insect nerve muscle. *The Journal of Experimental Biology* 30: 121–135.
- Huey, R.B., Crill, W. D., Kingsolver, J.G. and Weber, K.E. (1992). A method for rapid measurement of heat or cold resistance of small insects. *Functional Ecology* 6: 489–494.

- Jonusaite, S., Kelly, S.P. and Donini, A. (2011). The physiological response of larval *Chironomus riparius* (Meigen) to abrupt brackish water exposure. *Journal of Comparative Physiology B, Biochemical, Systemic, and Environmental Physiology* 181: 343–352.
- Kellermann, V., Van Heerwaarden, B., Sgrò, C.M. and Hoffmann, A.A. (2009). Fundamental evolutionary limits in ecological traits drive *Drosophila* species distributions. *Science* 325: 1244–1246.
- Kellermann, V., Loeschcke, V., Hoffmann, A.A., Kristensen, T.N., Fløjgaard, C., David, J.R., Svenning, J.-C. and Overgaard, J. (2012). Phylogenetic constraints in key functional traits behind species' climate niches: patterns of desiccation and cold resistance across 95 *Drosophila* species. *Evolution* 66: 3377–3389.
- Kelty, J. (2007). Rapid cold-hardening of *Drosophila melanogaster* in a field setting. *Physiological Entomology* 32, 343–350.
- Kelty, J.D. and Lee, R.E. (2001). Rapid cold-hardening of *Drosophila melanogaster* (Diptera: Drosophilidae) during ecologically based thermoperiodic cycles. *The Journal of Experimental Biology* 204: 1659–1666.
- Kimura, M.T. (2004). Cold and heat tolerance of drosophilid flies with reference to their latitudinal distributions. *Oecologia* 140: 442–449.
- Klok, C.J. and Chown, S.L. (2003). Resistance to temperature extremes in sub-Antarctic weevils: interspecific variation, population differentiation and acclimation. *Biological Journal of the Linnean Society* 78: 401–414.
- Košťál, V., Vambera, J. and Bastl, J. (2004). On the nature of pre-freeze mortality in insects: water balance, ion homeostasis and energy charge in the adults of *Pyrhocoris apterus*. *The Journal of Experimental Biology* 207: 1509–1521.
- Košťál, V., Yanagimoto, M. and Bastl, J. (2006). Chilling-injury and disturbance of ion homeostasis in the coxal muscle of the tropical cockroach (*Nauphoeta cinerea*). *Comparative Biochemistry and Physiology Part B, Biochemistry and Molecular Biology* 143: 171–179.
- Kristensen, T.N., Loeschcke, V., Bilde, T., Hoffmann, A.A., Sgró, C., Noreikienė, K., Ondrésik, M. and Bechsgaard, J.S. (2011). No inbreeding depression for low temperature developmental acclimation across multiple *Drosophila* species. *Evolution* 65: 3195–3201.
- Lachenicht, M.W., Clusella-Trullas, S., Boardman, L., Le Roux, C. and Terblanche, J.S. (2010). Effects of acclimation temperature on thermal tolerance, locomotion performance and respiratory metabolism in *Acheta domesticus* L. (Orthoptera: Gryllidae). *Journal of Insect Physiology* 56: 822–830.

- Lebovitz, R.M., Takeyasu, K. and Fambrough, D.M. (1989). Molecular characterization and expression of the (Na⁺ + K⁺)-ATPase alpha-subunit in *Drosophila melanogaster*. *The EMBO Journal* 8: 193–202.
- Lee, R.E. (1991). Principles of insect low temperature tolerance. In *Insects at Low Temperature* (ed. Lee, R. E. and Denlinger, D. L.), pp. 17–36. New York: Chapman and Hall.
- Lee, R.E., Chen, C. and Denlinger, D.L. (1987). A rapid cold-hardening process in insects. *Science* 238: 1415–1417.
- Legendre, P. and Desdevises, Y. (2009). Independent contrasts and regression through the origin. *Journal of Theoretical Biology* 259: 727–43.
- Legendre, P. (2013). lmodel2: Model II Regression. R package version 1.7-1. Available from: <http://CRAN.R-project.org/package=lmodel2>.
- Linton, S.M. and O'Donnell, M.J. (1999). Contributions of K⁺:Cl⁻ cotransport and Na⁺/K⁺-ATPase to basolateral ion transport in malpighian tubules of *Drosophila melanogaster*. *The Journal of Experimental Biology* 202: 1561–1570.
- Macdonald, S.S., Rako, L., Batterham, P. and Hoffmann, A.A. (2004). Dissecting chill coma recovery as a measure of cold resistance: evidence for a biphasic response in *Drosophila melanogaster*. *Journal of Insect Physiology* 50: 695–700.
- Mackay, T.F.C., Richards, S., Stone, E.A., Barbadilla, A., Ayroles, J.F., Zhu, D., Casillas, S., Han, Y., Magwire, M.M., Cridland, J.M., et al. (2012). The *Drosophila melanogaster* genetic reference panel. *Nature* 482: 173–178.
- MacMillan, H.A., Guglielmo, C.G. and Sinclair, B.J. (2009). Membrane remodeling and glucose in *Drosophila melanogaster*: a test of rapid cold-hardening and chilling tolerance hypotheses. *Journal of Insect Physiology* 55: 243–9.
- Markow, T.A. and O'Grady, P. (2005). *Drosophila: A Guide to Species Identification and Use*. London: Academic Press.
- Marshall, K.E. and Sinclair, B.J. (2010). Repeated stress exposure results in a survival-reproduction trade-off in *Drosophila melanogaster*. *Proceedings of the Royal Society B* 277: 963–969.
- Marygold, S.J., Leyland, P.C., Seal, R.L., Goodman, J.L., Thurmond, J., Strelets, V.B., Wilson, R.J. and Consortium, the F. (2013). FlyBase: improvements to the bibliography. *Nucleic Acids Research* 41: D751–D757.
- McDonough, A. and Farley, R. (1993). Regulation of Na,K-ATPase activity. *Current Opinion in Nephrology and Hypertension* 2: 725–734.

- McMullen, D.C. and Storey, K.B. (2008). Suppression of Na⁺K⁺-ATPase activity by reversible phosphorylation over the winter in a freeze-tolerant insect. *Journal of Insect Physiology* 54: 1023–1027.
- Mellanby, K. (1939). Low temperature and insect activity. *Proceedings of the Royal Society of London Series B* 127: 473–487.
- Messerli, M.A., Kurtz, I. and Smith, P.J.S. (2008). Characterization of optimized Na⁺ and Cl⁻ liquid membranes for use with extracellular, self-referencing microelectrodes. *Analytical and Bioanalytical Chemistry* 390: 1355–1359.
- Morgan, T.J. and Mackay, T.F.C. (2006). Quantitative trait loci for thermotolerance phenotypes in *Drosophila melanogaster*. *Heredity* 96: 232–42.
- Naikhwah, W. and O'Donnell, M.J. (2012). Phenotypic plasticity in response to dietary salt stress: Na⁺ and K⁺ transport by the gut of *Drosophila melanogaster* larvae. *The Journal of Experimental Biology* 215: 461–470.
- Natochin, Y.V and Parnova, R.G. (1987). Osmolarity and electrolyte concentration of hemolymph and the problem of ion and volume regulation of cells in higher insects. *Comparative Biochemistry and Physiology A* 88: 563–570.
- Newington, J.T., Pitts, A., Chien, A., Arseneault, R., Schubert, D. and Cumming, R.C. (2011). Amyloid beta resistance in nerve cell lines is mediated by the Warburg effect. *PLoS one* 6: e19191.
- Nilson, T.L., Sinclair, B.J. and Roberts, S.P. (2006). The effects of carbon dioxide anesthesia and anoxia on rapid cold-hardening and chill coma recovery in *Drosophila melanogaster*. *Journal of Insect Physiology* 52: 1027–1033.
- Nyamukondiwa, C., Terblanche, J.S., Marshall, K.E. and Sinclair, B.J. (2011). Basal cold but not heat tolerance constrains plasticity among *Drosophila* species (Diptera: Drosophilidae). *Journal of Evolutionary Biology* 24: 1927–1938.
- O'Donnell, M. (2008). Insect excretory mechanisms. *Advances in Insect Physiology* 35: 1–122.
- Ohtsu, T., Katagiri, C., Kimura, M. and Hori, S. (1993). Cold adaptations in *Drosophila*: Qualitative changes in triacylglycerols with relation to overwintering. *Journal of Biological Chemistry* 268: 1830–1834.
- Ohtsu, T., Kimura, M.T. and Katagiri, C. (1998). How *Drosophila* species acquire cold tolerance--qualitative changes of phospholipids. *European Journal of Biochemistry* 252: 608–11.
- Overgaard, J. and Sørensen, J.G. (2008). Rapid thermal adaptation during field temperature variations in *Drosophila melanogaster*. *Cryobiology* 56: 159–162.

- Overgaard, J., Sørensen, J.G., Petersen, S.O., Loeschcke, V. and Holmstrup, M. (2005). Changes in membrane lipid composition following rapid cold hardening in *Drosophila melanogaster*. *Journal of Insect Physiology* 51: 1173–1182.
- Overgaard, J., Malmendal, A., Sørensen, J.G., Bundy, J.G., Loeschcke, V., Nielsen, N.C. and Holmstrup, M. (2007). Metabolomic profiling of rapid cold hardening and cold shock in *Drosophila melanogaster*. *Journal of Insect Physiology* 53: 1218–1232.
- Overgaard, J., Tomčala, A., Sørensen, J.G., Holmstrup, M., Krogh, P.H., Šimek, P. and Košťál, V. (2008). Effects of acclimation temperature on thermal tolerance and membrane phospholipid composition in the fruit fly *Drosophila melanogaster*. *Journal of Insect Physiology* 54: 619–629.
- Overgaard, J., Kristensen, T.N., Mitchell, K.A. and Hoffmann, A.A. (2011). Thermal tolerance in widespread and tropical *Drosophila* species: does phenotypic plasticity increase with latitude? *The American Naturalist* 178 Supp.: S80–S96.
- Paradis, E., Claude, J. and Strimmer, K. (2004). APE: Analyses of phylogenetics and evolution in R language. *Bioinformatics* 20: 289–290.
- Patrick, M.L., Aimanova, K., Sanders, H.R. and Gill, S.S. (2006). P-type Na⁺/K⁺-ATPase and V-type H⁺-ATPase expression patterns in the osmoregulatory organs of larval and adult mosquito *Aedes aegypti*. *The Journal of Experimental Biology* 209: 4638–4651.
- Paul, S.M., Palladino, M.J. and Beitel, G.J. (2007). A pump-independent function of the Na,K-ATPase is required for epithelial junction function and tracheal tube-size control. *Development* 134: 147–155.
- Pierce, V.A., Mueller, L.D. and Gibbs, A.G. (1999). Osmoregulation in *Drosophila melanogaster* selected for urea tolerance. *The Journal of Experimental Biology* 202: 2349–2358.
- Pörtner, H.O. and Farrell, A.P. (2008). Physiology and climate change. *Science* 322: 690–692.
- Ransberry, V.E., MacMillan, H.A. and Sinclair, B.J. (2011). The relationship between chill-coma onset and recovery at the extremes of the thermal window of *Drosophila melanogaster*. *Physiological and Biochemical Zoology* 84: 553–559.
- Revell, L.J. (2012). phytools: an R package for phylogenetic comparative biology (and other things). *Methods in Ecology and Evolution* 3: 217–223.
- Rodgers, C.I., Armstrong, G.A.B. and Robertson, R.M. (2010). Coma in response to environmental stress in the locust: a model for cortical spreading depression. *Journal of Insect Physiology* 56: 980–990.

- Sanderson, M.J. (2002). Estimating absolute rates of molecular evolution and divergence times: a penalized likelihood approach. *Molecular biology and evolution* 19, 101–9.
- Schneider, C.A., Rasband, W.S. and Eliceiri, K.W. (2012). NIH Image to ImageJ: 25 years of image analysis. *Nature Methods* 9: 671–675.
- Schoner, W., Von Ilberg, C., Kramer, R. and Seubert, W. (1967). On the mechanism of Na^+ - and K^+ -stimulated hydrolysis of adenosine triphosphate. *European Journal of Biochemistry* 1: 334–343.
- Sinclair, B. and Roberts, S. (2005). Acclimation, shock and hardening in the cold. *Journal of Thermal Biology* 30: 557–562.
- Sinclair, B.J., Ferguson, L.V, Salehipour-Shirazi, G. and MacMillan, H.A. (in press) Cross-tolerance and cross-talk in the cold: Relating low temperatures to desiccation and immune stress in insects. *Integrative and Comparative Biology*.
- Sinclair, B. J., Klok, J.C. and Chown, S.L. (2004). Metabolism of the sub-Antarctic caterpillar *Pringleophaga marioni* during cooling, freezing and thawing. *The Journal of Experimental Biology* 207: 1287–1294.
- Somero, G.N. (2004). Adaptation of enzymes to temperature: searching for basic “strategies”. *Comparative biochemistry and physiology Part B, Biochemistry and Molecular Biology* 139: 321–333.
- Staszak, D.J. and Mutchmor, J.A. (1973). Influence of temperature on chill-coma and the electrical activity of the central and peripheral nervous systems of the American cockroach, *Periplaneta americana*. *Comparative Biochemistry and Physiology Part A: Molecular and Integrative Physiology* 45: 909–923.
- Storey, K.B. (1997). Organic solutes in freezing tolerance. *Comparative biochemistry and physiology. Part A, Physiology* 117: 319–26.
- Stork, T., Engelen, D., Krudewig, A., Silies, M., Bainton, R. J. and Klämbt, C. (2008). Organization and function of the blood-brain barrier in *Drosophila*. *The Journal of Neuroscience* 28: 587–597.
- Strachan, L.A., Tarnowski-Garner, H.E., Marshall, K.E. and Sinclair, B.J. (2011). The evolution of cold tolerance in *Drosophila* larvae. *Physiological and Biochemical Zoology* 84: 43–53.
- Sun, B. and Salvaterra, P.M. (1995). Characterization of nervana, a *Drosophila melanogaster* neuron-specific glycoprotein antigen recognized by anti-horseradish peroxidase antibodies. *Journal of Neurochemistry* 65: 434–43.
- Sun, B., Wang, W. and Salvaterra, P. (1998). Functional analysis and tissue-specific expression of *Drosophila* Na^+, K^+ -ATPase subunits. *Journal of Neurochemistry* 71: 142–151.

- Team, R.C. (2012). R: A language and environment for statistical computing. *R Foundation for Statistical Computing*.
- Teets, N.M., Kawarasaki, Y., Lee, R.E. and Denlinger, D.L. (2013). Expression of genes involved in energy mobilization and osmoprotectant synthesis during thermal and dehydration stress in the Antarctic midge, *Belgica antarctica*. *Journal of Comparative Physiology B* 183: 189–201.
- Telonis-Scott, M., Hallas, R., McKechnie, S.W., Wee, C.W. and Hoffmann, A.A. (2009). Selection for cold resistance alters gene transcript levels in *Drosophila melanogaster*. *Journal of insect physiology* 55: 549–55.
- Terblanche, J.S., Clusella-Trullas, S., Deere, J.A. and Chown, S.L. (2008). Thermal tolerance in a south-east African population of the tsetse fly *Glossina pallidipes* (Diptera, Glossinidae): implications for forecasting climate change impacts. *Journal of Insect Physiology* 54: 114–27.
- Therneau, T.M. and Grambsch, P.M. (2000). Modeling survival data: extending the Cox model. In *Statistics for Biology and Health* (ed. Dietz, K., Gail, M., Krickeberg, K., Samet, J., and Tsiatis, A.), New York: Springer.
- Trapnell, C., Pachter, L. and Salzberg, S.L. (2009). TopHat: discovering splice junctions with RNA-Seq. *Bioinformatics* 25: 1105–1111.
- Trapnell, C., Williams, B.A., Pertea, G., Mortazavi, A., Kwan, G., Van Baren, M.J., Salzberg, S. L., Wold, B.J. and Pachter, L. (2010). Transcript assembly and quantification by RNA-Seq reveals unannotated transcripts and isoform switching during cell differentiation. *Nature Biotechnology* 28: 511–515.
- Trapnell, C., Roberts, A., Goff, L., Pertea, G., Kim, D., Kelley, D.R., Pimentel, H., Salzberg, S. L., Rinn, J.L. and Pachter, L. (2012). Differential gene and transcript expression analysis of RNA-seq experiments with TopHat and Cufflinks. *Nature Protocols* 7: 562–578.
- Trapnell, C., Hendrickson, D.G., Sauvageau, M., Goff, L., Rinn, J.L. and Pachter, L. (2013). Differential analysis of gene regulation at transcript resolution with RNA-seq. *Nature Biotechnology* 31: 46–53.
- Van der Linde, K., Houle, D., Spicer, G.S. and Stepan, S.J. (2010). A supermatrix-based molecular phylogeny of the family Drosophilidae. *Genetics Research* 92: 25–38.
- Welinder, C. and Ekblad, L. (2011). Coomassie staining as loading control in Western blot analysis. *Journal of Proteome Research* 10: 1416–1419.
- Wyatt, G.R. (1961). The biochemistry of insect hemolymph. *Annual Review of Entomology* 6: 75–102.

- Wyatt, G.R. and Kalf, G.F. (1957). The chemistry of insect hemolymph II. trehalose and other carbohydrates. *The Journal of General Physiology* 40: 833–847.
- Yancey, P.H. (2005). Organic osmolytes as compatible, metabolic and counteracting cytoprotectants in high osmolarity and other stresses. *The Journal of experimental biology* 208: 2819–30.
- Zachariassen, K.E., Kristiansen, E. and Pedersen, S.A. (2004). Inorganic ions in cold-hardiness. *Cryobiology* 48: 126–133.

Chapter 7

7 General Discussion

7.1 Thesis summary

The majority of insects worldwide are chill-susceptible, and die at low temperatures from processes unrelated to freezing. The studies presented in this dissertation provide evidence for an important role of ionoregulatory physiology in setting limits to the performance of chill-susceptible insects. Unlike aquatic animals, insects do not appear to be limited at thermal extremes by their ability to effectively deliver oxygen to tissues (Chapter 3), which is likely owing to the abundance of available oxygen in air and efficiency of tracheal oxygen delivery. Insects nonetheless face challenges in osmotic and ionic regulation at low temperatures that are independent of energy availability. This loss in the ability to maintain ion balance leads to migration of Na^+ and water into the gut of *Gryllus pennsylvanicus* at low temperatures, resulting in elevation of extracellular $[\text{K}^+]$, depolarization of muscle membranes, and chilling injury (Chapter 4). Chill-coma recovery in *G. pennsylvanicus* appears to require recovery of ion and water balance. In particular, a reduction in extracellular $[\text{K}^+]$ to near resting levels facilitates restoration of muscle membrane potentials and the recovery of movement. The complete recovery of osmotic balance following chill-coma, however, costs the insect substantial time and metabolic energy, as Na^+ and water are slowly moved back to the hemocoel by active transport processes (Chapter 5). The metabolic rate of crickets in chill-coma is higher than that typical of insects in diapause (Chapter 3), and any energy that may be saved during low temperature exposure must be paid back during recovery (Chapter 5), meaning that chill-coma is unlikely to provide adaptive energy savings. Variation in cold tolerance is associated with modulation of ion and water balance in *Drosophila* (Chapter 6). Reductions in basal $[\text{Na}^+]$ and $[\text{K}^+]$ in the hemolymph likely reduce the tendency for Na^+ leak and keep extracellular $[\text{K}^+]$ low during cold exposure, and may thereby drive a reduction in the critical thermal minimum (CT_{min}). Together, this evidence suggests that disruption of ion and water homeostasis determine the physiological limits of chill-

susceptible insects, and that modulation of ion homeostasis may be an important means by which insects acquire cold tolerance.

7.2 A conceptual model of chill-susceptibility

The conclusions reached in chapters 2 through 6 can be integrated into the wider literature to generate a conceptual model of the ionoregulatory mechanisms setting limits to the performance of chill-susceptible insects. This approach allows for integration of three related, but physiologically distinct, measures of insect cold tolerance: chill-coma, chill-coma recovery, and chilling injury (Figure 7.1).

Exposure of chill-susceptible insects to low temperatures disrupts hemolymph ion homeostasis. Temperature alters the rates of enzymatic processes with a Q_{10} of 2-3, so cold exposure reduces the capacity for active translocation of ions across biological membranes by primary and secondary active ion transporters (e.g. Na^+/K^+ -ATPase, Ca^{2+} -ATPase, and the Na^+/H^+ -exchanger). By contrast, rates of passive ion leak through non-enzymatic paracellular pathways and transcellular channels are minimally impacted by temperature (Zachariassen et al., 2004). These differential effects of temperature on active and passive ion transport cause net ion leak down transmembrane and transepithelial gradients in the cold (Figure 7.1; see 2.4.3.1). During cold exposure, the transepithelial gradient for Na^+ across the gut wall, normally maintained by energetically demanding ion transport processes of the renal system (Section 1.4.2), is lost. With Na^+ , water leaves the hemocoel, depressing hemolymph volume and elevating extracellular $[\text{K}^+]$. In nerves, temperature-induced failure of ion transporters (particularly Na^+/K^+ -ATPase) also causes a rise in local extracellular $[\text{K}^+]$ (Rodgers et al., 2010), which is likely exacerbated by rising hemolymph $[\text{K}^+]$. Elevation of extracellular $[\text{K}^+]$ causes depolarization of muscle cells and neurons, rendering them unexcitable and causing chill-coma (Armstrong et al., 2012; Goller and Esch, 1990; Hosler et al., 2000; Staszak and Mutchmor, 1973; Figure 7.1).

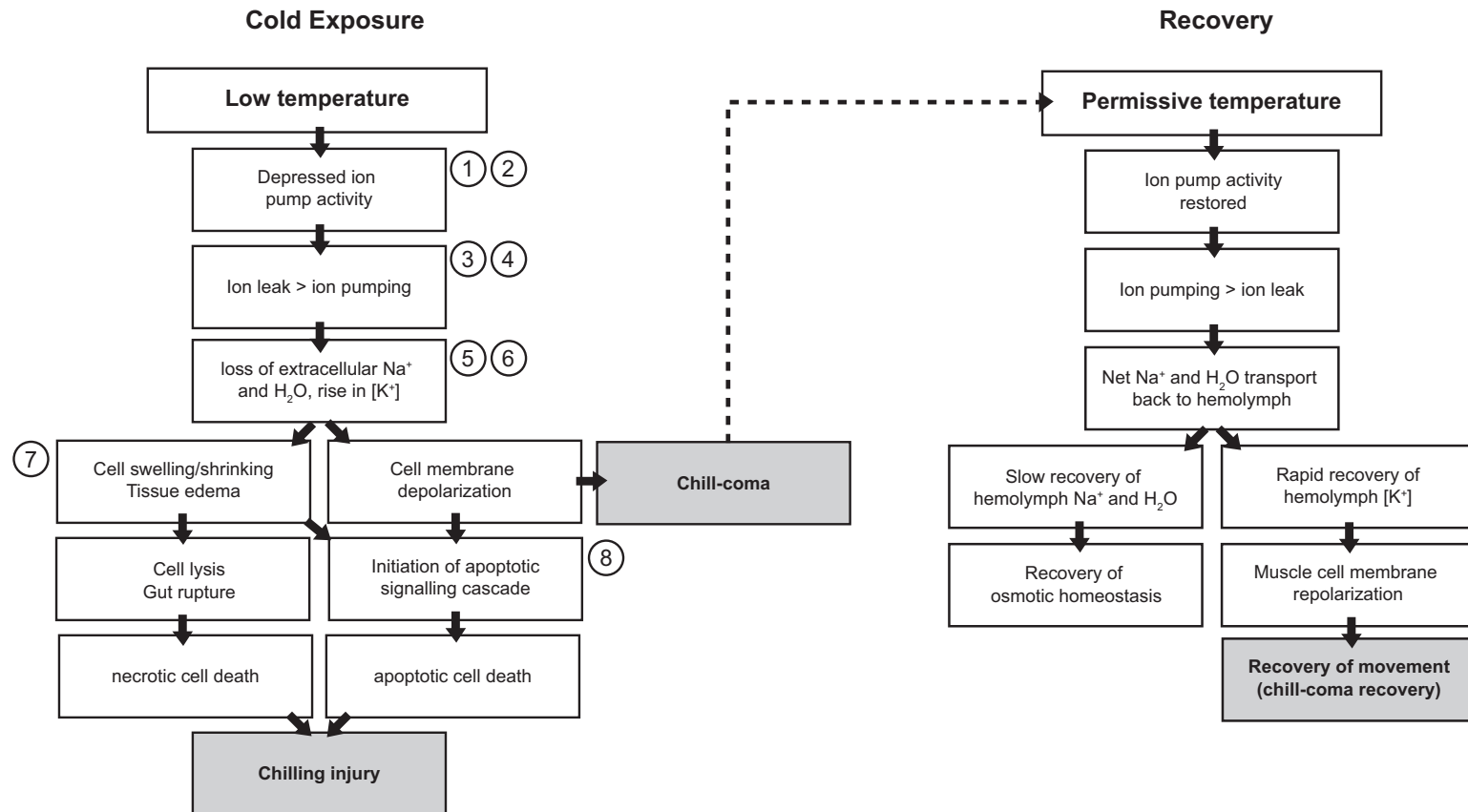

Figure 7.1. A physiological model integrating ionic mechanisms of chill-coma, chilling injury and chill-coma recovery in chill-susceptible insects. A temperature induced loss of ionoregulation leads to an inability to maintain ionic and osmotic gradients in the cold, leading to chill-coma through failure of nerve and muscle signal transmission. This loss of homeostasis leads to necrotic and apoptotic injury in a time and temperature dependent manner. Removal of the stress facilitates recovery by raising rates of ionoregulatory processes to resting conditions, which allows for chill-coma recovery. Complete osmotic recovery occurs more slowly than the recovery of movement, due to the non-linear relationship between hemolymph volume and K^+ concentration. The three most common measures of cold tolerance in chill-susceptible insects (grey) measure different consequences of the effects of temperature on ion balance. Numbers (1-8) represent the point in chain of causation that hypothesized mechanisms of cold tolerance plasticity (Table 7.1) might act.

Chill-susceptible insects continue to lose ion and water balance at temperatures below the CT_{min} , which can lead to chilling injury through apoptotic and necrotic cell death (Figure 7.1; Section 1.3.2.2; Lee et al., 2006a; Yi et al., 2007). The loss of ion and water balance in *G. pennsylvanicus* appears to be primarily driven by interactions between the hemolymph and gut, and severe loss of hemolymph water to the gut can cause the gut to rupture (Chapter 4). Evidence from other species suggests that other tissues are prone to a loss of water and ion balance. For example, adult firebugs (*Pyrrhocoris apterus*, Hemiptera: Pyrrhocoridae) lose K^+ and gain water in their fat body during cold exposure, which contributes to depolarization of resting membrane potential in fat body cells and cell swelling (Košťál et al., 2004). While excessive cell swelling can lead to necrosis, a modest gain of cell volume can also trigger initiation of the apoptotic-signaling cascade (Heimlich et al., 2004). With time spent at low temperatures increased incidence of apoptosis and necrosis cause chilling injuries and can eventually lead to death.

If a cold exposure is mild enough that substantial chilling injury has not occurred, chill-coma is reversible, and insects recover the ability to move following removal from the cold. When an insect is removed from the cold to a warmer temperature, rates of active ion transport increase to levels that exceed rates of ion leak (Figure 7.1). With time, ion gradients lost during the cold exposure are regenerated by active ion transport and restore excitability of muscles and nerves (Chapter 5). Hemolymph volume increases as Na^+ and water are returned to the extracellular space, which reduces extracellular $[K^+]$ and restores muscle resting potential (Chapter 5). In nerves, rapid removal of K^+ (via Na^+/K^+ -ATPase) from the extracellular space by neurons and glial cells following rewarming restores neuronal excitability (Armstrong et al., 2012; Rodgers et al., 2010). Repolarization of muscle cell potentials may also be aided by uptake of K^+ by the muscle cells during recovery (Chapter 5). Once muscle potentials are sufficiently restored to permit contraction, insects recover the ability to move, but restoration of ion and water balance may continue following the recovery of movement (Figure 7.1).

The three most common measures of the cold tolerance of chill-susceptible insects, the CT_{min} , chill-coma recovery time (CCR), and chilling injury, all appear to be

mechanistically associated with ion balance disruption or recovery, but are not analogous measures of physiological processes. Although the CT_{min} and CCR are associated with the loss and recovery of ion balance, CT_{min} is influenced by the thermal sensitivity of ion balance, while CCR is dependent on net rates of ion transport at the recovery temperature, and can be confounded with chilling injury following severe cold exposures (see Section 5.4.4). The differences in the physiology of CT_{min} and CCR mean that variation in one is not always reflected in variation in the other; indeed, these two traits are uncoupled in *Drosophila melanogaster* (Ransberry et al., 2011). Unlike the CT_{min} and CCR, chilling injury represents an ultimate, and generally irreversible, consequence of cold exposure on cell and tissue survival and function. Although injury following cold exposure may be a consequence of ion balance disruption, it is also likely to be influenced by other mechanisms of cellular stress in the cold, such as cold-induced oxidative stress and mismatches in metabolic pathways (Lalouette et al., 2007; Lalouette et al., 2011; Rojas and Leopold, 1996).

Although the CT_{min} , CCR and the incidence of chilling injury can all be useful measures of insect cold tolerance, they represent distinct consequences of the effects of low temperature on insect physiology. As such, researchers that aim to better understand the physiology underlying chill-coma and chilling injury should carefully consider which measure best fits the question at hand. For example, since the recovery of Na^+ and water homeostasis continues following the recovery of movement (Chapter 5), CCR is a poor measure of whole-organism homeostatic recovery. To understand the effects of repeated low temperature exposure on ion homeostasis and chilling injury onset, for example, CCR should not be used to plan the period, frequency, or severity of cold exposures. Because, as demonstrated in Chapter 5, insects that recover the ability to move are not necessarily at osmotic homeostasis.

7.3 Limitations and remaining gaps in the model

The studies presented in this dissertation leave several important questions unanswered, and there are some steps in the model that remain hypotheses (Figure 7.1). Filling

remaining gaps in the understanding of how cold impacts insect ionoregulatory physiology will require the combined efforts of specialists in both ionoregulatory physiology and thermal biology. With this improved understanding, mechanisms underlying variation in cold tolerance among species and populations, and previously unknown means by which insects can rapidly modify cold tolerance, will hopefully come to light.

7.3.1 Taxonomic and contextual expansion of the conceptual model

All of my experiments were conducted on laboratory-reared animals of either a single genus (*Drosophila*) or a single species (*G. pennsylvanicus*), and it remains unclear if the mechanisms of cold limitation presented apply to all chill-susceptible insects. The hypothesis that cold exposure causes ionoregulatory disruption must continue to be rigorously tested in a wide range of insect species, both in the lab and in the field, to either support or refute its general applicability.

The mechanisms by which insects maintain extracellular ion homeostasis are diverse (Beyenbach et al., 2010; Fitzgerald et al., 1996; Phillips, 1981), so it is unlikely that the specific mechanisms thought to underlie the loss of ion balance in *G. pennsylvanicus* and *Drosophila* apply to all insect taxa. Not all insects maintain high hemolymph $[\text{Na}^+]$. Some coleopteran species have higher concentrations of Mg^{2+} than Na^+ in their hemolymph, and lepidopterans maintain high hemolymph carbohydrate levels in the place of Na^+ (Dissanayake and Zachariassen, 1980; Fitzgerald et al., 1996). Many lepidopterans even have slightly higher concentrations of Na^+ in their muscle cells than in the hemolymph (Fitzgerald et al., 1996), which implies that failure of Na^+ gradients may not drive muscle failure in this Order. Nonetheless, hemolymph $[\text{K}^+]$ and $[\text{Ca}^{2+}]$ are important to muscle excitability, and nerve conduction is dependent on $[\text{K}^+]$ of the immediate neuronal environment, of all insects, so general patterns of ion balance disruption may become clear following a broad taxonomic analysis. If cold exposure causes a decline in hemolymph $[\text{Ca}^{2+}]$ and water content, and an increase in hemolymph $[\text{K}^+]$ in all insects, such patterns could lead to the identification of important molecular targets of cold tolerance adaptation and plasticity. As a useful starting point, the effects of

cold exposure on hemolymph ion composition and water content could be compared among multiple members of several insect orders reared under common conditions.

Whether insects in the wild face similar ionoregulatory challenges to those reared under controlled conditions in the laboratory is uncertain, but chill-coma does occur in nature. For example, Edwards (1970) found species of eight insect orders in chill-coma on the divide between two Alaskan glaciers, which apparently lost the ability to move as they migrated through the area. Sampling of insects that have experienced a cold snap in the wild could reveal if ion balance disruption is associated with chill-coma under natural conditions. The fall field cricket (*G. pennsylvanicus*) is widely distributed across North America, and is easy to collect in the wild (particularly because of the calling behaviour of males). This species could be further used to confirm if the cold-induced patterns of ion balance disruption observed in the laboratory hold in crickets collected from their natural environment.

7.3.2 Does ion balance disruption cause chill-coma and chilling injury?

All of my experiments on the role of ion balance disruption in chill-coma and chilling injury were of a correlative nature (Chapters 4-6). Chill-coma and chilling injury are certainly coincident with ion balance disruption in *G. pennsylvanicus* (Chapter 4), and chill-coma recovery is coincident with the restoration of ion balance (Chapter 5), but causal roles of ion balance disruption in chill-coma and chilling injury have not been confirmed.

Aspects of the model presented in Section 7.2 should be directly tested through experimental intervention. For example, if chill-coma onset is driven by rising hemolymph $[K^+]$, injection of K^+ into the hemocoel should induce chill-coma at temperatures above the CT_{min} , and reductions in hemolymph K^+ through injection of a K^+ -free hemolymph mimic (to dilute K^+) or stimulation of K^+ clearance from the hemocoel (for example, by stimulation of renal H^+ V-ATPase coupled transport of K^+ ; see 7.4.2) should improve CCR following (or even during) cold exposure and reduce chilling injury. The hypothesized role of Na^+/K^+ -ATPase and other ion-motive ATPases

in the cold induced loss of ion and water balance should also be directly tested. This could be accomplished through targeted increases or decreases in ATPase expression in the renal system, or by specific pharmacological inhibition of ATPase activity *in situ*. These experiments will either support or refute a causal role of ion balance disruption in chill-coma and chilling injury.

Insect mortality is coincident with the continued disruption of ion homeostasis at low temperatures (Chapters 4 and 5; Košťál et al., 2006; Košťál et al., 2004), and cold exposure has been noted to cause apoptosis and necrosis in several insect tissues (Yi et al., 2007). The physiological mechanisms that link chilling injury to ion balance disruption and cell death, however, are unclear. Changes in cell volume and intracellular concentrations of K^+ , Cl^- and Ca^{2+} can all initiate apoptotic signaling (Heimlich et al., 2004). If the loss of hemolymph ion balance is a principal driver of cell death in insects at low temperatures and if cell death is the primary driver of chilling injury, maintenance of the intracellular environment alone should facilitate cellular and organismal survival.

Cold exposure induces electrical silence in both the muscles and nerves, and impairs central synaptic transmission, of insects (Chapter 2; Bradfish et al., 1982; Esch, 1988; Goller and Esch, 1990; Hosler et al., 2000; Staszak and Mutchmor, 1973). To date, however, no study has compared function of these components of the neuromuscular signaling pathway in the same insect during cooling, so it remains unclear if nerve axons, synapses, or muscle cells represent the “weakest link” that sets the insect CT_{min} . The ionoregulatory mechanisms thought to underlie neural failure at low temperatures largely mirror those that impact the muscles, and both failure and recovery of the nervous system during and following cold exposure occurs rapidly and on a local scale in both *Drosophila* and migratory locusts (*Locusta migratoria*, Orthoptera: Acrididae; Armstrong et al., 2012; Rodgers et al., 2010). By contrast, chill-coma recovery following prolonged cold exposure appears to require the relatively slow process of restoring muscle excitability through restoration of hemolymph composition (Chapter 5). Failure of either nerve conduction or synaptic transmission may thus be a determinant of the CT_{min} , whereas CCR is dependent on the recovery of muscle excitability. This hypothesis could be addressed by tissue-specific experimental manipulation of ionoregulatory enzyme

activity in *D. melanogaster*. Reductions in ion transport capacity in the nervous system would be expected to preferentially impact CT_{\min} over CCR, whereas such a change in the renal system may more strongly affect CCR. Application of this method, however, will require a clear understanding of how, specifically, ion transport mechanisms of the gut epithelia are impacted by cold.

7.3.3 Elucidating the routes of ion and water migration in the cold

It is evident that water and ions in the hemolymph of *G. pennsylvanicus* move to the gut during cold exposure, but the routes by which they cross the gut epithelia were not determined. Hindgut Na^+ content rises sharply during exposure to 0 °C in *G. pennsylvanicus*, which suggests that either the hindgut or Malpighian tubules (which originate at the midgut-hindgut junction) may be the principal site of Na^+ leak at low temperatures (Section 4.2.4). This hypothesis could be tested by comparing the effects of cold on ion and water transport rates at the gut epithelia *ex situ*. There are well-developed methods for measuring gut epithelial transport that can be easily adapted for study of the effects of temperature on transport rates, such as Ramsay and Ussing chamber assays (e.g. O'Donnell, 2009; Ramsay, 1952; De Wolf and Van Driessche, 1986). The distribution of water among tissues can be visualized in live insects using, for example, 1H magnetic resonance imaging and spectroscopy (Mietchen et al., 2008). Such an approach could be used to observe the gut of a chill-susceptible insect during cooling. Together, these approaches could clarify which portions of the insect gut are most sensitive to chilling, allowing for study of the specific mechanisms of ion and water transport most relevant to insect cold tolerance.

7.4 What are the mechanisms of cold tolerance plasticity and evolution?

The cold tolerance of chill-susceptible insects can be improved through adaptation to cold climates, long-term acclimatization or acclimation, or even brief (i.e. 30 min) exposure to a non-lethal low temperature (Gibert and Huey, 2001; Lee et al., 1987; Ransberry et al., 2011). This variation in insect cold tolerance can be used to better understand the physiology of chill-coma and chilling injury, and to test the underlying assumptions of

the model presented in section 7.2. Following from the conclusions drawn in chapters 2 through 6, I have identified eight physiological mechanisms by which insect cold tolerance might be altered through phenotypic plasticity or evolutionary adaptation that warrant further investigation (Table 7.1).

Although I found only weak evidence for variation in the thermal sensitivity of Na⁺/K⁺-ATPase among species of the *Drosophila* genus, insects may improve their ability to maintain ion homeostasis in the cold by modifying the thermal sensitivity of this, or other critical ion transporters (Table 7.1). Such differences in thermal sensitivity may manifest *in vivo* via changes in the fluidity of biological membranes, which strongly impact the function of membrane-bound enzymes. Some insects may be capable of limiting rates of ion and water leak through channel arrest and tightening of paracellular junctions (Table 7.1). Variation in insect cold tolerance could be driven by modulation of transcellular or transepithelial gradients of ions, such as Na⁺ or K⁺, as was observed in *Drosophila* (Chapter 6, Table 7.1). If ion leak is unavoidable in the cold, insects might modulate rates of water migration by sequestering or reducing the expression of aquaporins in critical tissues (Table 7.1). Lastly, when all else fails, survival may be improved by inhibition of apoptotic signaling pathways, which would limit cell death following low temperature exposure (Table 7.1).

Table 7.1. Physiological mechanisms hypothesized to underlie variation in the cold tolerance of chill susceptible insects. Row numbers (1-8) correspond to numbers in Figure 7.1.

Mechanism	Potential effects	Evidence/Support	Citation
1. Reduced ion transporter thermal sensitivity	<ul style="list-style-type: none"> - Maintenance of ion and water balance - Faster recovery from chill-coma 	<ul style="list-style-type: none"> - Low Na⁺/K⁺-ATPase thermal sensitivity in cold tolerant <i>Drosophila</i> species 	Chapter 6
2. Increased membrane fluidity	<ul style="list-style-type: none"> - Sustained ion transporter activity - Reduced risk of membrane damage - Faster recovery from chill-coma 	<ul style="list-style-type: none"> - Cold tolerance is associated with decreased saturation of fatty acids in membrane phospholipids 	(Košťál and Šimek, 1998; Ohtsu et al., 1998; Overgaard et al., 2005; Overgaard et al., 2008)
3. Channel arrest	<ul style="list-style-type: none"> - Reduced transmembrane ion leak - Reduced transcellular ion leak - Maintenance of water balance 	<ul style="list-style-type: none"> - Cricket muscles maintain intracellular ion and water stores in the cold despite gradients favouring leak - Channel arrest protects against hypoxia in other organisms 	Chapter 4 (Boutillier, 2001; Hochachka, 1986)
4. Tightening of paracellular pathways	<ul style="list-style-type: none"> - Reduced rates of ion and water leak in the cold - Faster recovery from chill-coma - Decreased incidence of apoptosis and necrosis 	<ul style="list-style-type: none"> - Diuretic and antidiuretic signaling can rapidly influence paracellular transport in the insect renal system 	(Beyenbach et al., 2009)
5. Reduction in resting Na⁺ gradients	<ul style="list-style-type: none"> - Reduced rates of Na⁺ leak in the cold - Maintenance of water balance - Reduced apoptotic and necrotic cell death - Faster recovery from chill-coma 	<ul style="list-style-type: none"> - Cold-tolerant <i>Drosophila</i> have low hemolymph [Na⁺] - Cold acclimated cockroaches have hypopolarized muscle E_{Na} 	Chapter 6 (Košťál et al., 2006)
6. Increase in K⁺ gradients	<ul style="list-style-type: none"> - Sustained membrane potential and movement at low temperatures - Reduced apoptotic cell death - Faster recovery from chill-coma 	<ul style="list-style-type: none"> - Cold-tolerant <i>Drosophila</i> species maintain low hemolymph [K⁺] - Cold acclimated cockroaches have hyperpolarized muscle E_K 	Chapter 6 (Košťál et al., 2006)
7. Suppression of aquaporin expression	<ul style="list-style-type: none"> - Maintenance of water balance - Reduced apoptotic and necrotic cell death 	<ul style="list-style-type: none"> - Freeze tolerance is associated with <u>high</u> aquaporin expression 	(Goto et al., 2011; Izumi et al., 2006; Philip and Lee, 2010)
8. Inhibition of apoptotic signaling	<ul style="list-style-type: none"> - Reduced apoptotic cell death 	<ul style="list-style-type: none"> - RCH inhibits apoptosis - Ca²⁺ is important in cellular cold sensing and is necessary for RCH 	(Yi and Lee, 2011; Yi et al., 2007; Teets et al., 2008; Teets et al., 2012)

7.4.1 Variation in ion pump thermal sensitivity and the role of the membrane environment

Improvements in cold tolerance may be achieved through changes in the thermal sensitivity of ionoregulatory enzymes, or in the membrane environment in which such enzymes reside. Such modifications are likely to permit maintenance of ion gradients to lower temperatures by limiting net rates of ion and water flux in the cold (Table 7.1).

Variation in the thermal sensitivity of Na^+/K^+ -ATPase may be a mechanism of evolved variation in the CT_{min} , and not phenotypic plasticity; there was a marginally non-significant relationship between the critical thermal minima of *Drosophila* species and the thermal sensitivity of Na^+/K^+ -ATPase, but warm- cold-acclimated *D. melanogaster* did not differ in Na^+/K^+ -ATPase thermal sensitivity (Chapter 6). In other ectotherms, among-species variation in enzyme thermal sensitivity primarily arise as a result of differences in the primary gene sequence, or differences in RNA editing. Such modifications to thermal sensitivity can be a product of changes in the enzyme catalytic constant (k_{cat}), or the Michaelis-Menten constant (K_{m}), or both (Dong and Somero, 2009; Galarza-Muñoz et al., 2011; Garrett and Rosenthal, 2012; Somero, 2004).

Modulation of the thermal sensitivity of rates of ion transport *in vivo* may also act through modification of the membrane environment in which active ion transporters reside (Table 7.1). Both the thermal sensitivity and reaction rate of Na^+/K^+ -ATPase activity depend on the composition of membrane bilayer; phospholipid fatty acid saturation and chain length as well as cholesterol content of the membrane all interact to determine Na^+/K^+ -ATPase pumping rate and thermal sensitivity (Cornelius, 2001; Esmann and Marsh, 2006). Modification of membrane fluidity through changes in membrane bilayer constituents is documented in relation to cold acclimation and adaptation of *Drosophila* (Košťál and Šimek, 1998; Ohtsu et al., 1998; Overgaard et al., 2005; 2008; but see MacMillan et al., 2009). Thus, membrane composition might play a critical role in cold tolerance plasticity and evolution among insects, not only through protection of the membrane from physical damage, but also through maintenance of active ion transport rates at low temperatures.

An understanding of the molecular mechanisms that contribute to differences in the thermal sensitivity of ion-motive ATPase orthologs will require gene sequence analysis and comparison of the kinetics of highly purified proteins in a common membrane environment. Ion pumps or their subunits, such as the Na⁺/K⁺-ATPase α -subunit could be cloned from the 12 species of the *Drosophila* genus that have, thus far, had their genomes sequenced (Clark et al., 2007; Markow and O'Grady, 2007). Expression of Na⁺/K⁺-ATPase α -subunits in *Xenopus* oocytes would allow for a comparison of thermal sensitivity of this enzyme in a common membrane environment (and with a common β -subunit; Galarza-Muñoz et al., 2011). This approach could lead to the identification of changes in protein sequences that have contributed to enzyme cold-adaptation. In addition, experimental modification of phospholipid fatty acids or head groups, or membrane cholesterol content (Cornelius, 2001; Esmann and Marsh, 2006) could reveal interactive effects of protein sequence and membrane composition on the thermal sensitivity of ion transport that would otherwise be undetected.

7.4.2 Modulation of transcellular and paracellular permeability

Cold tolerance adaptation and plasticity are likely to be mediated in part through reductions in the permeability of transcellular and paracellular pathways to ions and water in critical tissues, principally those that compose the nervous and renal systems (Table 7.1). Modifications to transcellular permeability to ions and water are likely to occur through modulation of the number and localization of ion channels and aquaporins, respectively. Modifications to paracellular permeability are primarily documented to occur through remodeling of intercellular junctions.

Active ion transport across cell membranes is necessitated by rates of passive leak of ions down their electrochemical gradients, which occurs primarily through ion channels. The channel arrest hypothesis (Hochachka, 1986) proposes that hypoxia tolerant animals reduce rates of ion leak across membranes when O₂ is scarce. Frogs (*Rana temporaria*) submerged under water respond by reducing the permeability of their muscle cell membranes to ions, which maintains intracellular K⁺ levels and facilitates low Na⁺/K⁺-ATPase activity (Donohoe et al., 2000). This adaptive physiological response allows for maintenance of ion balance under conditions of hypoxia by dramatically

reducing the energetic demands of active ion transport (Boutilier, 2001; Hochachka, 1986).

In the cold, channel arrest may similarly protect the intracellular ion concentrations of insect muscles. The muscles of crickets (*G. pennsylvanicus*) and tropical cockroaches (*Nauphoeta cinerea*, Blattodea: Blaberidae) maintain stable levels of intracellular cations during chronic cold exposure, despite large ion gradients across the muscle cell membrane favouring leak (Chapter 4; Košťál et al., 2006). The muscles of some insects may thus be capable of channel arrest in response to low temperatures, which would limit ion and water flux across the cell membranes of the muscles and protect against apoptotic and necrotic cell death in the cold (Table 7.1). To my knowledge, the role of channel arrest in insect cold tolerance has not been studied.

Variation in basal and inducible cold tolerance is likely to be associated with variation in transcellular and paracellular permeability in the insect renal system. Pathways of ion and water movement are highly plastic and under tight hormonal control in insects (For review see: Gäde, 2004). For example, stimulation of Malpighian tubules of mosquitos (*Aedes Aegypti*, Diptera: Culicidae) with a diuretic peptide (adeskinin) almost instantaneously increases rates of ion and water secretion by increasing both H⁺ V-ATPase activity and paracellular permeability (Beyenbach, 2003; Beyenbach et al., 2009). Desert locust (*Schistocerca gregaria*, Orthoptera: Acrididae) hindgut absorption rates are similarly stimulated by ion transport peptide (ITP), which is produced and excreted into the hemolymph by the corpus cardiacum (Audsley et al., 2013; Phillips and Audsley, 1995). Peptide hormones signaling can thus rapidly alter rates of ion and water transport at both the Malpighian tubules and the hindgut, and coordinated adjustments in transport rates could facilitate maintenance of ion and water balance in the cold. As a starting point for testing this hypothesis, the relationship between phenotypic plasticity in cold tolerance and plasticity in hormone titres should be examined in a model insect such as *L. migratoria*, in which the roles of several diuretic and antidiuretic hormones have been well characterized.

Insect neurons are protected from hemolymph ion composition by the tight septate junctions of glial cells that make up the blood-brain barrier (Stork et al., 2008). The barrier functions of septate junctions are dependent on cytoskeletal structure, and cold exposure disorganizes the cytoskeleton of *Drosophila* muscle, nerve and fat cells in culture (Cottam et al., 2006). Thus, a loss of neuronal ion and water balance in the cold may, in part, be driven by increased paracellular permeability of the blood-brain barrier. Improvements in paracellular barrier function may be achieved through increased expression of septate junction proteins in the perineurial glia, which is the primary barrier to K^+ leak into the neuronal extracellular space (Kocmarek and O'Donnell, 2011; Stork et al., 2008; Table 7.1). If this hypothesis is correct, cold-adaptation and cold tolerance plasticity should be associated with high expression of paracellular junction components and low blood-brain barrier permeability to K^+ . In support of this hypothesis, cold-acclimated *D. melanogaster* had higher expression of *nrv2* transcripts (Chapter 6). The *nrv2* gene codes for a Na^+/K^+ -ATPase β -subunit isoform, and this protein plays an essential role in septate junction formation. This role of Nrv2 is independent of the ion transporting activities of Na^+/K^+ -ATPase (Paul et al., 2007).

Reductions in transmembrane water flux could be driven by reductions in aquaporin expression or removal of aquaporins from the membrane bilayer. In *Drosophila* and house crickets (*Acheta domesticus*, Orthoptera: Gryllidae), secretion into the Malpighian tubules is largely mediated by passive transcellular flux of water through an aquaporin called *Drosophila* integral protein (DRIP; Kaufmann et al., 2005; Spring, 2009; Spring et al., 2007). Stimulation of house cricket Malpighian tubules with achetakinin-2 causes insertion of DRIP into both the apical and basolateral membranes of mid-tubule cells, which increases rates of water transport (Spring et al., 2007). Low temperature acclimation and RCH in chill-susceptible insects may thus be associated with increased resistance to water flux across the Malpighian tubule cells, facilitated, conversely, by removal of aquaporins from Malpighian tubule membranes (Table 7.1). This hypothesized role for aquaporins in the cold tolerance of chill-susceptible insects is opposite to their apparent role in freeze tolerant species, in which high aquaporin expression facilitates rapid water flux during freezing. Increased expression of an aquaporin (EsAQP1) following seasonal acclimatization in the freeze-tolerant goldenrod

gall fly (*Eurosta solidaginis*, Diptera: Tephritidae), allows water to leave cells during extracellular freezing, and thereby promotes cell survival over winter (Izumi et al., 2006; Philip et al., 2008; 2011). If a reduction in the number of functioning aquaporins can contribute to improvements in cold tolerance, insects are expected to have reduced expression and membrane localization of aquaporins in renal and neuromuscular systems following cold acclimation, RCH and seasonal acclimatization.

7.4.3 Modification of cellular and epithelial ion gradients and diet effects on cold tolerance

Insects may limit ion and water flux in the cold by modifying ion gradients. Both cold-acclimated *Drosophila melanogaster* and cold-tolerant *Drosophila* species maintained low extracellular $[\text{Na}^+]$, implying maintenance of low Na^+ gradients might improve cold tolerance (Chapter 6). A reduction in Na^+ gradients across gut epithelia or cell membranes is likely to limit Na^+ and water flux to the gut or into cells during cold exposure, and mitigate detrimental increases in extracellular $[\text{K}^+]$ (Table 7.1). Because hemolymph $[\text{Na}^+]$ is a strong determinant of hemolymph osmotic pressure, however, reductions in hemolymph $[\text{Na}^+]$ are expected to be associated with modest increases in other determinants of osmotic pressure, such as other ions (e.g. Mg^{2+}) carbohydrates, or free amino acids (Section 6.4.3).

Cold tolerant *Drosophila* species also maintained low extracellular $[\text{K}^+]$ (Chapter 6), which implies that cold tolerance may be related to hyperpolarization of K^+ gradients across cell membranes or epithelia. The maintenance of high K^+ gradients across cell membranes would maintain cell potential despite hemolymph volume losses and rising extracellular $[\text{K}^+]$, but may require additional metabolic investment to be maintained. These hypotheses can be further addressed by quantifying the effects of cold acclimation on muscle cell resting potential. If cold-acclimated insects maintain higher gradients of $[\text{K}^+]$ across muscle cell membranes, they likely have elevated intracellular $[\text{K}^+]$ and hyperpolarized muscle cell membranes relative to warm-acclimated insects.

Transepithelial gradients for ions across the gut epithelia depend heavily on feeding status and the salt content of the diet. Decreased K^+ in the gut of migratory locusts

(*L. migratoria*) during starvation causes a reduction in hemolymph $[K^+]$ of approximately 40 %, and diets high in K^+ cause elevated hemolymph $[K^+]$ (Hoyle, 1954). Locusts fed on high K^+ diets have low muscle cell resting potentials, generate less force during muscle contraction, and cannot jump as far as those fed on low K^+ diets (Hoyle, 1954). Since increased hemolymph $[K^+]$ also appears to limit muscle function at low temperatures (Chapters 4-6), dietary K^+ content and feeding status likely have strong effects on the cold tolerance of chill susceptible insects. By contrast, dietary Na^+ content may inversely influence cold tolerance; high $[Na^+]$ in the gut lumen from a high Na^+ diet may reduce the gradient favouring Na^+ leak into the gut during cold exposure. These hypotheses could be most simply addressed through artificial diet manipulation in a laboratory-reared insect, such as *D. melanogaster*. In such a case, high K^+ and low Na^+ diets are expected to decrease CT_{min} , slow CCR, and increase the incidence of chilling injury following cold exposure. If the effects of rearing and acclimation temperature on insect cold tolerance can be modulated by the salt content of the diet, diet choice experiments may reveal preferences for dietary Na^+ and K^+ intake at different temperatures. Laval and adult *D. melanogaster* and locust nymphs (*L. migratoria*) are capable of discerning differences in NaCl content of diets (Arora et al., 1987; Miyakawa, 1982), so this hypothesis could be addressed by adding temperature treatments to classical diet choice experimental designs.

In the wild, chill-susceptible insects may modify the salt content of their diet, or cease feeding in response to seasonal climate patterns and thereby modulate cold tolerance. This hypothesis could be addressed by characterizing cold tolerance in relation to gut contents and hemolymph ion concentrations in fall active insect (such as *G. pennsylvanicus*) during a seasonal temperature decline. Interestingly, many freeze avoidant insects void or eliminate their gut in preparation for winter. This strategy facilitates suppression of the supercooling point by eliminating potential ice nucleators in the gut (Lee et al., 1996; Pullin et al., 1991; Zachariassen, 1985), but may also minimize the influence of the gut on cold tolerance by decreasing ion gradients across the gut wall. If feeding cessation and gut clearance facilitate maintenance of ion homeostasis at low temperatures, insects that have been fasted are expected to have a higher probability of survival than fed individuals following exposure to non-freezing low temperatures.

Individuals that have cleared or eliminated their gut during a seasonal temperature decline are also expected to suffer less indirect chilling injury during a low temperature stress than individuals that have not yet done so.

7.4.4 Inhibition of apoptosis – a final stand against chilling injury?

If disruption of ion and water homeostasis cannot be avoided by the physiological mechanisms described above, inhibition of apoptotic signaling pathways may be a mechanism by which chilling injury can still be avoided. This method of protecting cells against cold-induced damage could occur despite ion balance disruption (i.e. it is only necessary if apoptotic signals would otherwise be active), and so may represent a cellular block against chilling injury that would be induced by disruption of cellular ion and water balance (Table 7.1). The RCH response in *D. melanogaster* has been associated with protection from apoptotic cell death in several cold-sensitive tissues (Yi and Lee, 2011; Yi et al., 2007). Pre-exposure of *D. melanogaster* to a non-lethal low temperature protects against apoptosis by inhibiting the activation of caspases that normally initiate the apoptotic cascade, and intracellular $[Ca^{2+}]$ plays an important role in cellular temperature sensing (Yi and Lee, 2011; Teets et al., 2012). Cold exposure causes a rapid increase in intracellular $[Ca^{2+}]$ in cells of both freeze tolerant and chill-susceptible dipterans that causes activation of the Ca^{2+} /calmodulin dependent protein kinase II (CaMKII; Teets et al., 2012). Extracellular Ca^{2+} is necessary for cellular activation of RCH, and temperature-induced reductions in Ca^{2+} -ATPase and Na^+/Ca^{2+} exchanger activity at the cell membrane and endoplasmic reticulum are thought to cause this Ca^{2+} influx (Teets et al., 2008; Teets et al., 2012). Thus, protective inhibition of apoptosis (via Ca^{2+} influx) and the loss of Na^+ and K^+ homeostasis may be mediated by similar effects of low temperatures on different ionoregulatory enzymes.

In addition to directly protecting cells against apoptosis through caspase inhibition, Ca^{2+} signaling may be necessary for activation of other mechanisms thought to protect against chilling injury. For example, CaMKII leads to inactivation of voltage sensitive Na^+ channels (I_{Na}) and sequestration of ATP sensitive K^+ channels (K_{ATP}) in mammalian cardiomyocytes (Ashpole et al., 2012; Sierra et al., 2013). This inactivation and removal of ion channels mirrors patterns observed in “channel arrest” that protects some

vertebrates against ion leak in anoxia (Section 7.4.2). Thus, Ca^{2+} signaling may similarly lead to reductions in transmembrane permeability to K^+ and Na^+ in insect muscles, or transcellular Na^+ permeability in the insect renal system during cold exposure. If this hypothesis is correct, removal of Ca^{2+} from the bathing medium up these tissues *ex situ* should exacerbate Na^+ or K^+ leak in the cold.

7.5 Concluding remarks

In conclusion, disruption of extracellular ion and water homeostasis appear to mediate the susceptibility of insects to chill-coma and chilling injury, and recovery of insects from low temperature stress requires restoration of ion balance. In addition, plasticity and evolution of insect cold tolerance appear to be mechanistically tied to modification of ion homeostasis. What is clear from this concluding chapter, however, is there is much work to be done before a clear understanding can be reached of how ionoregulatory physiology impacts insect cold tolerance. To generate informed predictions of insect distribution in a changing climate, several broad questions must be answered that necessitate this mechanistic understanding. For example, how are insects able to beneficially respond to rapid changes in temperature? What are the genetic and physiological constraints on adaptation to thermal variability? Is plasticity in cold tolerance constrained by evolutionary history, and if so how do such constraints manifest on a physiological level? A thorough understanding of the detrimental effects of cold on chill-susceptible insects, and the means by which insect cold-tolerance can be modulated will require integration of concepts from several fields of comparative physiology and molecular and cell biology. Insect ionoregulatory and thermal physiology have long histories of independent study, and improved understanding in both fields will hopefully be facilitated by collaborative research efforts in the future. I look forward to addressing some of the hypotheses outlined in this concluding chapter personally, and I hope the ideas presented here are of use to the wider research community.

7.6 Literature cited

- Armstrong, G.A.B., Rodríguez, E.C. and Robertson, R.M. (2012). Cold hardening modulates K⁺ homeostasis in the brain of *Drosophila melanogaster* during chill coma. *Journal of Insect Physiology* 58: 1511–1516.
- Ashpole, N.M., Herren, A.W., Ginsburg, K.S., Brogan, J.D., Johnson, D.E., Cummins, T.R., Bers, D.M. and Hudmon, A. (2012). Ca²⁺/calmodulin-dependent protein kinase II (CaMKII) regulates cardiac sodium channel Na_v1.5 gating by multiple phosphorylation sites. *The Journal of Biological Chemistry* 287: 19856–19869.
- Arora, K., Rodrigues, V., Joshi, S., Shanbhag, S. and Siddiqi, O. (1987). A gene affecting the specificity of the chemosensory neurons of *Drosophila*. *Nature* 331: 62–63.
- Audsley, N., Jensen, D. and Schooley, D. A. (2013). Signal transduction for *Schistocerca gregaria* ion transport peptide is mediated via both cyclic AMP and cyclic GMP. *Peptides* 41: 74–80.
- Beyenbach, K.W. (2003). Regulation of tight junction permeability with switch-like speed. *Current Opinion in Nephrology and Hypertension* 12: 543–550.
- Beyenbach, K.W., Baumgart, S., Lau, K., Piermarini, P.M. and Zhang, S. (2009). Signaling to the apical membrane and to the paracellular pathway: changes in the cytosolic proteome of Aedes Malpighian tubules. *The Journal of Experimental Biology* 212: 329–40.
- Beyenbach, K.W., Skaer, H. and Dow, J.A.T. (2010). The developmental, molecular, and transport biology of Malpighian tubules. *Annual Review of Entomology* 55: 351–374.
- Boutillier, R.G. (2001). Mechanisms of cell survival in hypoxia and hypothermia. *The Journal of Experimental Biology* 204: 3171–81.
- Bradfish, G.A., Drewes, C.D. and Mutchmor, J.A. (1982). The effects of cooling on an identified reflex pathway in the cockroach (*Periplaneta americana*), in relation to chill-coma. *The Journal of Experimental Biology* 96: 131–141.
- Clark, A.G., Eisen, M.B., Smith, D.R., Bergman, C.M., Oliver, B., Markow, T.A., Kaufman, T.C., Kellis, M., Gelbart, W., Iyer, V.N., et al. (2007). Evolution of genes and genomes on the *Drosophila* phylogeny. *Nature* 450: 203–218.
- Cornelius, F. (2001). Modulation of Na,K-ATPase and Na-ATPase activity by phospholipids and cholesterol. I. Steady-state kinetics. *Biochemistry* 40: 8842–8851.
- Cottam, D.M., Tucker, J.B., Rogers-Bald, M.M., Mackie, J.B., Macintyre, J., Scarborough, J.A., Ohkura, H. and Milner, M. J. (2006). Non-centrosomal microtubule-organising centres in cold-treated cultured *Drosophila* cells. *Cell Motility and the Cytoskeleton* 63: 88–100.

- De Wolf, I. and Van Driessche, W. (1986). Voltage-dependent Ba^{2+} block of K^+ channels in apical membrane of frog skin. *American Journal of Physiology: Cell Physiology* 251: C696–C706.
- Dissanayake, P. and Zachariassen, K.E. (1980). Effect of warm acclimation on the cationic concentrations in the extracellular and intracellular fluid of hibernating *Rhagium inquisitor* beetles. *Comparative Biochemistry and Physiology* 65A: 347–350.
- Dong, Y. and Somero, G.N. (2009). Temperature adaptation of cytosolic malate dehydrogenases of limpets (genus *Lottia*): differences in stability and function due to minor changes in sequence correlate with biogeographic and vertical distributions. *The Journal of Experimental Biology* 212: 169–177.
- Donohoe, P.H., West, T.G. and Boutilier, R.G. (2000). Factors affecting membrane permeability and ionic homeostasis in the cold-submerged frog. *The Journal of Experimental Biology* 203: 405–414.
- Edwards, J.S. (1970). Insect fallout on the Gulkana glacier, Alaska range. *The Canadian Entomologist* 102: 1169–1170.
- Esch, H. (1988). The effects of temperature on flight muscle potentials in honeybees and cuculiinid winter moths. *The Journal of Experimental Biology* 135: 109–117.
- Esmann, M. and Marsh, D. (2006). Lipid-protein interactions with the Na,K-ATPase. *Chemistry and physics of lipids* 141: 94–104.
- Fitzgerald, E.M., Djamgoz, M.B.A. and Dunbar, S.J. (1996). Maintenance of the K^+ activity gradient in insect muscle compared in Diptera and Lepidoptera: contributions of metabolic and exchanger mechanisms. *The Journal of Experimental Biology* 199: 1857–1872.
- Gäde, G. (2004). Regulation of intermediary metabolism and water balance of insects by neuropeptides. *Annual Review of Entomology* 49: 93–113.
- Galarza-Muñoz, G., Soto-Morales, S.I., Holmgren, M. and Rosenthal, J.J.C. (2011). Physiological adaptation of an Antarctic Na^+/K^+ -ATPase to the cold. *The Journal of Experimental Biology* 214: 2164–2174.
- Garrett, S. and Rosenthal, J.J.C. (2012). RNA editing underlies temperature adaptation in K^+ channels from polar octopuses. *Science* 335: 848–851.
- Gibert, P. and Huey, R.B. (2001). Chill-coma temperature in *Drosophila*: Effects of developmental temperature, latitude, and phylogeny. *Physiological and Biochemical Zoology* 74: 429–434.

- Goller, F. and Esch, H. (1990). Comparative study of chill-coma temperatures and muscle potentials in insect flight muscles. *The Journal of Experimental Biology* 150: 221–231.
- Goto, S.G., Philip, B.N., Teets, N.M., Kawarasaki, Y., Lee, R.E. and Denlinger, D.L. (2011). Functional characterization of an aquaporin in the Antarctic midge *Belgica antarctica*. *Journal of Insect Physiology* 57: 1106–14.
- Heimlich, G., Bortner, C.D. and Cidlowski, J.A. (2004). Apoptosis and cell volume regulation the importance of ions and ion channels. *Advances in Experimental Medicine and Biology* 559: 189–203.
- Hochachka, P. (1986). Defense strategies against hypoxia and hypothermia. *Science* 231: 234–241.
- Hosler, J.S., Burns, J.E. and Esch, H.E. (2000). Flight muscle resting potential and species-specific differences in chill-coma. *Journal of Insect Physiology* 46: 621–627.
- Hoyle, G. (1954). Changes in the blood potassium concentration of the African migratory locust (*Locusta migratoria Migratorioides* R. & F.) during food deprivation, and the effect on neuromuscular activity. *The Journal of Experimental Biology* 31: 260–270.
- Izumi, Y., Sonoda, S., Yoshida, H., Danks, H.V and Tsumuki, H. (2006). Role of membrane transport of water and glycerol in the freeze tolerance of the rice stem borer, *Chilo suppressalis* Walker (Lepidoptera: Pyralidae). *Journal of Insect Physiology* 52: 215–20.
- Kaufmann, N., Mathai, J.C., Hill, W.G., Dow, J.A.T., Zeidel, M.L. and Brodsky, J.L. (2005). Developmental expression and biophysical characterization of a *Drosophila melanogaster* aquaporin. *American Journal of Physiology. Cell physiology* 289: C397–407.
- Kocmarek, A.L. and O'Donnell, M.J. (2011). Potassium fluxes across the blood brain barrier of the cockroach, *Periplaneta americana*. *Journal of Insect Physiology* 57: 127–135.
- Koštál, V. and Šimek, P. (1998). Changes in fatty acid composition of phospholipids and triacylglycerols after cold-acclimation of an aestivating insect prepupa. *Comparative Biochemistry and Physiology Part B* 168: 453–460.
- Koštál, V., Vambera, J. and Bastl, J. (2004). On the nature of pre-freeze mortality in insects: water balance, ion homeostasis and energy charge in the adults of *Pyrrhocoris apterus*. *The Journal of Experimental Biology* 207: 1509–1521.

- Koštál, V., Yanagimoto, M. and Bastl, J. (2006). Chilling-injury and disturbance of ion homeostasis in the coxal muscle of the tropical cockroach (*Nauphoeta cinerea*). *Comparative Biochemistry and Physiology Part B, Biochemistry and Molecular Biology* 143: 171–179.
- Lalouette, L., Košťál, V., Colinet, H., Gagneul, D. and Renault, D. (2007). Cold exposure and associated metabolic changes in adult tropical beetles exposed to fluctuating thermal regimes. *The FEBS Journal* 27: 1759–1767.
- Lalouette, L., Williams, C.M., Hervant, F., Sinclair, B.J. and Renault, D. (2011). Metabolic rate and oxidative stress in insects exposed to low temperature thermal fluctuations. *Comparative Biochemistry and Physiology. Part A, Molecular and Integrative Physiology* 158: 229–234.
- Lee, R.E., Chen, C. and Denlinger, D.L. (1987). A rapid cold-hardening process in insects. *Science* 238: 1415–1417.
- Lee, R., Costanzo, J. and Mugano, J. (1996). Regulation of supercooling and ice nucleation in insects. *European Journal of Entomology* 93: 405–418.
- Lee, R.E., Damodaran, K., Yi, S.-X. and Lorigan, G.A. (2006). Rapid cold-hardening increases membrane fluidity and cold tolerance of insect cells. *Cryobiology* 52: 459–463.
- MacMillan, H.A., Guglielmo, C.G. and Sinclair, B.J. (2009). Membrane remodeling and glucose in *Drosophila melanogaster*: a test of rapid cold-hardening and chilling tolerance hypotheses. *Journal of Insect Physiology* 55: 243–249.
- Markow, T.A. and O’Grady, P.M. (2007). *Drosophila* biology in the genomic age. *Genetics* 177: 1269–1276.
- Mietchen, D., Manz, B., Volke, F. and Storey, K. (2008). In vivo assessment of cold adaptation in insect larvae by magnetic resonance imaging and magnetic resonance spectroscopy. *PLoS one* 3: e3826.
- Miyakawa, Y. (1982). Behavioural evidence for the existence of sugar, salt and amino acid taste receptor cells and some of their properties in *Drosophila* larvae. *Journal of Insect Physiology* 28: 405–410.
- O’Donnell, M. J. (2009). Too much of a good thing: how insects cope with excess ions or toxins in the diet. *The Journal of Experimental Biology* 212: 363–372.
- Ohtsu, T., Kimura, M.T. and Katagiri, C. (1998). How *Drosophila* species acquire cold tolerance - qualitative changes of phospholipids. *European Journal of Biochemistry* 252: 608–611.

- Overgaard, J., Sørensen, J.G., Petersen, S.O., Loeschcke, V. and Holmstrup, M. (2005). Changes in membrane lipid composition following rapid cold hardening in *Drosophila melanogaster*. *Journal of Insect Physiology* 51: 1173–1182.
- Overgaard, J., Tomčala, A., Sørensen, J.G., Holmstrup, M., Krogh, P.H., Šimek, P. and Košťál, V. (2008). Effects of acclimation temperature on thermal tolerance and membrane phospholipid composition in the fruit fly *Drosophila melanogaster*. *Journal of Insect Physiology* 54: 619–629.
- Paul, S.M., Palladino, M.J. and Beitel, G.J. (2007). A pump-independent function of the Na,K-ATPase is required for epithelial junction function and tracheal tube-size control. *Development* 134: 147–155.
- Philip, B.N. and Lee, R.E. (2010). Changes in abundance of aquaporin-like proteins occurs concomitantly with seasonal acquisition of freeze tolerance in the goldenrod gall fly, *Eurosta solidaginis*. *Journal of Insect Physiology* 56: 679–685.
- Philip, B.N., Yi, S.-X., Elnitsky, M.A. and Lee, R.E. (2008). Aquaporins play a role in desiccation and freeze tolerance in larvae of the goldenrod gall fly, *Eurosta solidaginis*. *The Journal of Experimental Biology* 211: 1114–1119.
- Philip, B.N., Kiss, A.J. and Lee, R.E. (2011). The protective role of aquaporins in the freeze-tolerant insect *Eurosta solidaginis*: functional characterization and tissue abundance of EsAQP1. *The Journal of Experimental Biology* 214: 848–857.
- Phillips, J. (1981). Comparative physiology of insect renal function. *The American Journal of Physiology: Regulatory, Integrative and Comparative Physiology* 241: 241–257.
- Phillips, J.E. and Audsley, N. (1995). Neuropeptide control of ion and fluid transport across locust hindgut. *American Zoologist* 35: 503–514.
- Pullin, A.S., Bale, J.S. and Fontaine, X.L.R. (1991). Physiological aspects of diapause and cold tolerance during overwintering in *Pieris brassicae*. *Physiological Entomology* 16: 447–456.
- Ramsay, J.A. (1952). The excretion of sodium and potassium by the malpighian tubules of *Rhodnius*. *The Journal of Experimental Biology* 29: 110–126.
- Ransberry, V.E., MacMillan, H.A. and Sinclair, B.J. (2011). The relationship between chill-coma onset and recovery at the extremes of the thermal window of *Drosophila melanogaster*. *Physiological and Biochemical Zoology* 84: 553–559.
- Rodgers, C.I., Armstrong, G.A.B. and Robertson, R.M. (2010). Coma in response to environmental stress in the locust: a model for cortical spreading depression. *Journal of Insect Physiology* 56: 980–990.

- Rojas, R.R. and Leopold, R.A. (1996). Chilling injury in the housefly: Evidence for the role of oxidative stress between pupariation and emergence. *Cryobiology* 33: 447–458.
- Sierra, A., Zhu, Z., Sapay, N., Sharotri, V., Kline, C.F., Luczak, E.D., Subbotina, E., Sivaprasadarao, A., Snyder, P.M., Mohler, P.J., et al. (2013). Regulation of cardiac ATP-sensitive potassium channel surface expression by calcium/calmodulin-dependent protein kinase II. *The Journal of Biological Chemistry* 288: 1568–1581.
- Somero, G.N. (2004). Adaptation of enzymes to temperature: searching for basic “strategies”. *Comparative biochemistry and physiology Part B, Biochemistry and Molecular Biology* 139: 321–333.
- Spring, J.H., Robichaux, S.R. and Hamlin, J.A. (2009). The role of aquaporins in excretion in insects. *The Journal of Experimental Biology* 212: 358–362.
- Spring, J.H., Robichaux, S.R., Kaufmann, N. and Brodsky, J.L. (2007). Localization of a *Drosophila* DRIP-like aquaporin in the Malpighian tubules of the house cricket, *Acheta domesticus*. *Comparative Biochemistry and Physiology Part A: Molecular and Integrative Physiology* 148: 92–100.
- Staszak, D.J. and Mutchmor, J.A. (1973). Influence of temperature on chill-coma and the electrical activity of the central and peripheral nervous systems of the American cockroach, *Periplaneta americana*. *Comparative Biochemistry and Physiology Part A: Molecular and Integrative Physiology* 45: 909–923.
- Stork, T., Engelen, D., Krudewig, A., Silies, M., Bainton, R.J. and Klämbt, C. (2008). Organization and function of the blood-brain barrier in *Drosophila*. *The Journal of Neuroscience* 28: 587–597.
- Teets, N.M., Elnitsky, M.A., Benoit, J.B., Lopez-Martinez, G., Denlinger, D.L. and Lee, R.E. (2008). Rapid cold-hardening in larvae of the Antarctic midge *Belgica antarctica*: cellular cold-sensing and a role for calcium. *American Journal of Physiology: Regulatory, integrative and Comparative Physiology* 294: R1938–R1946.
- Teets, N. M., Yi, S.-X., Lee, R.E. and Denlinger, D. L. (in press). Calcium signaling mediates cold sensing in insect tissues. *Proceedings of the National Academy of Sciences of the United States of America*.
- Yi, S.-X. and Lee, R.E. (2011). Rapid cold-hardening blocks cold-induced apoptosis by inhibiting the activation of pro-caspases in the flesh fly *Sarcophaga crassipalpis*. *Apoptosis* 16: 249–255.
- Yi, S.-X., Moore, C.W. and Lee, R.E. (2007). Rapid cold-hardening protects *Drosophila melanogaster* from cold-induced apoptosis. *Apoptosis* 12: 1183–1193.

Zachariassen, K.E. (1985). Physiology of cold tolerance in insects. *Physiological Reviews* 65: 799–832.

Zachariassen, K.E., Kristiansen, E. and Pedersen, S.A. (2004). Inorganic ions in cold-hardiness. *Cryobiology* 48: 126–133.

Appendix A: Chapter 4 supplementary material

Table A.1. Results of false discovery rate corrected t-tests and general linear models of hemolymph and muscle ion concentrations and calculated muscle equilibrium potentials of *Gryllus pennsylvanicus* exposed to 0 °C. t-tests were used to compare ion concentrations and equilibrium potentials between control crickets and crickets exposed to 0 °C for 12 h. General linear models were then used to examine the effect of prolonged cold exposure (up to 120 h) on ion concentrations and equilibrium potentials and include control crickets only if there was no difference between control and 12 h. *P*-values in bold denote significant effects of cold exposure on the response variable.

Ion	Test	Variable	df	Stat	<i>P</i> -value
Na⁺	t-test	Hemolymph Concentration	10	<i>t</i> =3.26	0.024
		Muscle Concentration	10	<i>t</i> =4.385	0.008
		Equilibrium Potential	10	<i>t</i> =0.77	0.461
	General Linear Model	Hemolymph Concentration	2,58	<i>F</i> =13.35	<0.001
		Muscle Concentration	2,58	<i>F</i> =0.27	0.606
		Equilibrium Potential	2,64	<i>F</i> =0.91	0.345
K⁺	t-test	Hemolymph Concentration	11	<i>t</i> =4.13	0.008
		Muscle Concentration	10	<i>t</i> =0.12	0.907
		Equilibrium Potential	10	<i>t</i> =2.11	0.244
	General Linear Model	Hemolymph Concentration	2,58	<i>F</i> =31.23	<0.001
		Muscle Concentration	2,64	<i>F</i> =0.01	0.786
		Equilibrium Potential	2,64	<i>F</i> =45.74	<0.001
Mg²⁺	t-test	Hemolymph Concentration	11	<i>t</i> =2.85	0.032
		Muscle Concentration	10	<i>t</i> =0.84	0.563
		Equilibrium Potential	10	<i>t</i> =1.17	0.357
	General Linear Model	Hemolymph Concentration	2,64	<i>F</i> =0.70	0.398
		Muscle Concentration	2,64	<i>F</i> =0.01	0.955
		Equilibrium Potential	2,64	<i>F</i> =1.83	0.181
Ca²⁺	t-test	Hemolymph Concentration	10	<i>t</i> =1.86	0.144
		Muscle Concentration	9	<i>t</i> =0.15	0.907
		Equilibrium Potential	9	<i>t</i> =1.24	0.357
	General Linear Model	Hemolymph Concentration	2,59	<i>F</i> =16.03	<0.001
		Muscle Concentration	2,60	<i>F</i> =0.56	0.458
		Equilibrium Potential	2,52	<i>F</i> =5.51	0.023

Table A.2. Results of false discovery rate corrected t-tests and general linear models of hemolymph and tissue water content of *Gryllus pennsylvanicus* exposed to 0 °C. t-tests were used to compare water content between control crickets and crickets exposed to 0 °C for 6 h. General linear models were then used to examine the effect of prolonged cold exposure (up to 120 h) on water content, and include control crickets only if there was no difference between control and 6 h. *P*-values in bold denote significant effects of cold exposure on water content.

Test	Tissue	df	Stat	<i>P</i>-value
t-test	Hemolymph	11	$t=1.35$	0.603
	Muscle	10	$t=0.70$	0.782
	Gut Total	11	$t=0.55$	0.782
	Foregut	13	$t=1.97$	0.070
	Midgut	13	$t=2.15$	0.051
	Hindgut	13	$t=3.11$	0.008
General Linear Model	Hemolymph	2,49	$F=88.68$	<0.001
	Muscle	2,63	$F=1.20$	0.277
	Gut Total	2,51	$F=7.13$	0.010
	Foregut	2,60	$F=2.12$	0.038
	Midgut	2,60	$F=44.68$	<0.001
	Hindgut	2,52	$F=0.28$	0.597

Table A.3. Results of false discovery rate corrected t-tests and general linear models of hemolymph, foregut, midgut and hindgut ion content of *Gryllus pennsylvanicus* exposed to 0 °C. t-tests were used to compare ion content between control crickets and crickets exposed to 0 °C for 6 h. General linear models were then used to examine the effect of prolonged cold exposure (up to 120 h) on ion content, and include control crickets only if there was no difference between control and 6 h. *P*-values in bold denote significant effects of cold exposure on ion content.

Ion	Test	Tissue	df	Stat	<i>P</i> -value
Na⁺	t-test	Hemolymph	13	<i>t</i> =2.61	0.068
		Foregut	13	<i>t</i> =1.60	0.322
		Midgut	13	<i>t</i> =4.10	0.006
		Hindgut	13	<i>t</i> =5.42	0.001
	General Linear Model	Hemolymph	2,66	<i>F</i> =97.78	<0.001
		Foregut	2,57	<i>F</i> =2.77	0.008
		Midgut	2,60	<i>F</i> =4.83	0.032
		Hindgut	2,52	<i>F</i> =12.96	<0.001
K⁺	t-test	Hemolymph	13	<i>t</i> =1.98	0.085
		Foregut	14	<i>t</i> =0.65	0.631
		Midgut	14	<i>t</i> =2.91	0.044
		Hindgut	14	<i>t</i> =0.11	0.915
	General Linear Model	Hemolymph	2,67	<i>F</i> =0.10	0.758
		Foregut	2,57	<i>F</i> =2.03	0.160
		Midgut	2,52	<i>F</i> =4.95	0.031
		Hindgut	2,60	<i>F</i> =3.21	0.078
Mg²⁺	t-test	Hemolymph	13	<i>t</i> =2.37	0.068
		Foregut	13	<i>t</i> =1.27	0.405
		Midgut	14	<i>t</i> =0.91	0.572
		Hindgut	12	<i>t</i> =1.85	0.264
	General Linear Model	Hemolymph	2,66	<i>F</i> =61.60	<0.001
		Foregut	2,53	<i>F</i> =0.48	0.491
		Midgut	2,60	<i>F</i> =19.44	<0.001
		Hindgut	2,60	<i>F</i> =2.54	0.116
Ca²⁺	t-test	Hemolymph	13	<i>t</i> =1.863	0.085
		Foregut	13	<i>t</i> =1.46	0.334
		Midgut	14	<i>t</i> =0.78	0.597
		Hindgut	14	<i>t</i> =0.44	0.727
	General Linear Model	Hemolymph	2,65	<i>F</i> =67.53	<0.001
		Foregut	2,55	<i>F</i> =0.85	0.359
		Midgut	2,60	<i>F</i> =21.58	<0.001
		Hindgut	2,60	<i>F</i> =1.64	0.205

Appendix B: Chapter 5 supplementary material

Table B.1. Results of linear and non-linear regression of cricket chill-coma recovery time and cold exposure duration. Four visual indices of chill-coma recovery were recorded: first coordinated contraction of the abdomen, movement of the forelegs, movement of the hind legs, and the ability of a cricket to independently right itself (Righting). *F*- and *P*-values of the exponent parameter are shown separately for exponential models. Models of best fit (bold face) were chosen based on Akaike information criterion (AIC), with an AIC difference of 2 required for selection of the more complex exponential model. Statistical significance was determined on adjusted *P* values (*P*.adj) following false discovery rate correction (See 5.3.5 for details).

Index	Model	<i>df</i>	<i>F</i>	<i>P</i>	<i>F</i> (exponent)	<i>P</i> (exponent)	Log Likelihood	AIC	<i>P</i> .adj
<i>Abdomen</i>	Linear	38	958.9	<0.001			-83.9	175.8	
	Exponential	38	2603.5	<0.001	67.8	<0.001	-77.5	165.0	<0.001, <0.001
<i>Forelegs</i>	Linear	38	363.3	<0.001			-106.6	221.1	
	Exponential	38	6863.7	<0.001	8.7	<0.001	-89.2	188.4	<0.001, <0.001
<i>Hindlegs</i>	Linear	38	155.1	<0.001			-113.5	234.9	
	Exponential	38	5851.3	<0.001	0.1	<0.001	-97.3	204.5	<0.001, 0.001
<i>Righting (<24 h)</i>	Linear	38	267.7	<0.001			-151.1	310.3	
	Exponential	38	1675.5	0.002	3.2	0.073	-147.0	304.1	0.002, 0.073
<i>Activity detection</i>	Linear	30	306.9	<0.001			-93.4	192.9	
	Exponential	30	814.7	<0.001	13.2	0.001	-82.3	172.6	<0.001, 0.001

Table B.2. Results of t-tests of the effects of 24 h of exposure to 0 °C on hemolymph, muscle and gut ion and water content. Statistical significance (bold face) was determined on adjusted *P*-values (*P.adj*) following false discovery rate correction (see 5.3.5 for details). Dir: direction of change.

Tissue	Variable	df	t	P	<i>P</i> _{adj}	Dir
<i>Hemolymph</i>	Volume	12	6.55	<0.001	0.001	-
	Na⁺ (μmol)	18	4.65	<0.001	0.001	-
	K ⁺ (μmol)	18	1.01	0.322	0.322	
	[Na⁺]	14	3.10	<0.001	0.017	-
	[K⁺]	10	2.80	0.019	0.024	+
<i>Muscle</i>	Water content	17	0.16	0.873	0.873	
	[Na ⁺]	18	1.12	0.277	0.582	
	[K ⁺]	15	0.19	0.844	0.873	
	E _{Na}	17	0.96	0.349	0.582	
	E_K	13	3.37	0.005	0.025	+
<i>Foregut</i>	Water content	18	3.04	0.007	0.021	+
	Na⁺ content	17	2.71	0.017	0.025	+
	K ⁺ content	18	1.39	0.182	0.182	
<i>Midgut</i>	Water content	16	5.53	<0.001	<0.001	+
	Na⁺ content	17	2.37	0.030	0.045	+
	K ⁺ content	15	2.03	0.061	0.061	
<i>Hindgut</i>	Water content	17	2.52	0.022	0.066	
	Na ⁺ content	15	1.51	0.151	0.227	
	K ⁺ content	17	0.70	0.488	0.488	
<i>Gut Total</i>	Water content	17	4.29	<0.001	0.002	+
	Na⁺ content	14	3.33	0.005	0.008	+
	K ⁺ content	17	0.30	0.772	0.772	

Table B.3. Results of linear (L) and non-linear (NL) models (M) of *G. pennsylvanicus* hemolymph, muscle and gut ion and water content during chill-coma recovery following 24 h at 0 °C. Models of best fit (bold face) were chosen based on Akaike information criterion (AIC), with an AIC difference of 2 required for selection of the more complex exponential model. Variables that could not be effectively fit to a given model are marked (N/A) and are considered non-significant. *F*- and *P*-values of the exponent parameter are shown separately for exponential models. Statistical significance was determined on adjusted *P*-values (*P*.*adj*) following false discovery rate correction. LL: Log likelihood ratio. Dir: direction of change.

Tissue	Variable	M	df	<i>F</i>	<i>P</i>	LL	AIC	<i>P</i> . <i>adj</i>	Dir
Hemolymph	Volume	L	44	1629.3	<0.001	-141.6	291.2	<0.001	+
		NL	44	4004.2,354.1	0.590,0.658	-141.0	292.1		
	Na ⁺ content	L	42	644.6	<0.001	-86.7	181.5	<0.001	+
		NL	42	900.5,91.7	0.652,0.729	-86.7	183.5		
	K ⁺ content	L	39	117.7	0.602	-47.9	103.8	0.602	
		NL	39	81.0,32.5	0.347,0.755	-49.2	108.4		
	[Na ⁺]	L	34	1309.1	0.513	-152.2	312.4	0.602	
		NL	N/A	N/A	N/A	N/A	N/A	N/A	
	[K ⁺]	L	34	161.3	<0.001	-116.0	239.9		
NL		34	87.4,41.3	0.004,0.158	-111.0	232.1	0.008, 0.237	-	
Muscle	H ₂ O content	L	47	1.33	0.255	-52.8	113.5	0.306	
		NL	47	0.2,1.4	0.651,0.241	-53.2	116.4		
	[Na ⁺]	L	43	224.2	0.011	-147.8	303.6	0.022	+
		NL	43	88.9,40.6	0.997,0.999	-151.8	313.7		
	[K ⁺]	L	43	815.1	0.002	-183.0	374.0	0.006	+
		NL	43	1875.7,2.2	0.903,0.886	-183.0	375.9		
	E _{Na}	L	42	167.7	0.812	-170.6	349.2	0.812	
		NL	42	85.9,88.7	0.994,0.974	-170.3	350.7		
	E _k	L	43	546.7	<0.001	-164.6	347.1		
NL		43	760.0,56.9	<0.001,0.201	-163.3	336.6	0.001,0.301	-	
Foregut	H ₂ O content	L	47	0.6	0.115	-128.0	264.0	0.345	
		NL	47	0.1,5.2	0.711,0.023	-128.1	266.2		
	Na ⁺ content	L	47	0.5	0.500	-51.9	111.8	0.750	
		NL	47	0.1,0.1	0.742,0.721	-52.3	114.7		
	K ⁺ content	L	47	0.1	0.887	-26.7	61.4	0.887	
		NL	47	0.1,0.1	0.724,0.963	-26.9	63.7		
Midgut	H ₂ O content	L	43	0.7	0.143	-115.5	239.0		
		NL	43	8.5,4.4	0.001,0.302	-111.7	233.3	0.005,0.378	-
	Na ⁺ content	L	42	1.0	0.532	-43.6	95.3		
		NL	42	2.4,1.9	0.030,0.178	-41.2	92.3	0.075,0.297	
	K ⁺ content	L	40	0.1	0.478	-13.8	35.7	0.478	
		NL	40	0.1,0.1	0.911,0.994	-14.2	38.4		
Hindgut	H ₂ O content	L	45	3.4	0.010	-112.3	232.6	0.010	-
		NL	45	1.2,7.8	0.005,0.294	-111.0	232.2		
	Na ⁺ content	L	43	8.1	<0.001	-37.4	82.8	0.001	-
		NL	43	0.2,41.0	0.654,<0.001	-37.3	84.5		
	K ⁺ content	L	42	9.3	0.004	-25.9	59.8	0.012	+
		NL	42	253.6,0.2	<0.001,0.683	-25.6	61.3		
Gut Total	H ₂ O content	L	43	0.8	0.018	-144.0	296.0	0.027	-
		NL	43	5.1,4.0	0.005,0.267	-142.2	294.4		
	Na ⁺ content	L	42	3.1	0.007	-70.4	148.8	0.022	-
		NL	42	0.1,29.7	0.603,<0.001	-69.9	149.8		
	K ⁺ content	L	40	3.85	0.192	-48.8	105.6	0.192	
		NL	40	43.4,0.3	<0.001,0.996	-49.3	108.6		

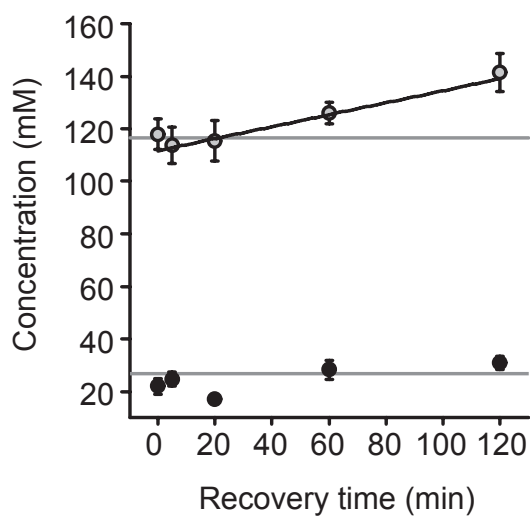

Figure B.1. Muscle concentration of Na⁺ (black) and K⁺ (grey) during chill-coma recovery at 22 °C following 24 h at 0 °C. B). Grey lines indicate mean values of control crickets (those that did not receive any cold exposure). Cold exposure did not significantly affect Na⁺ or K⁺ concentration of the muscle. Solid black line indicates a significant relationship between recovery time and K⁺ concentration.

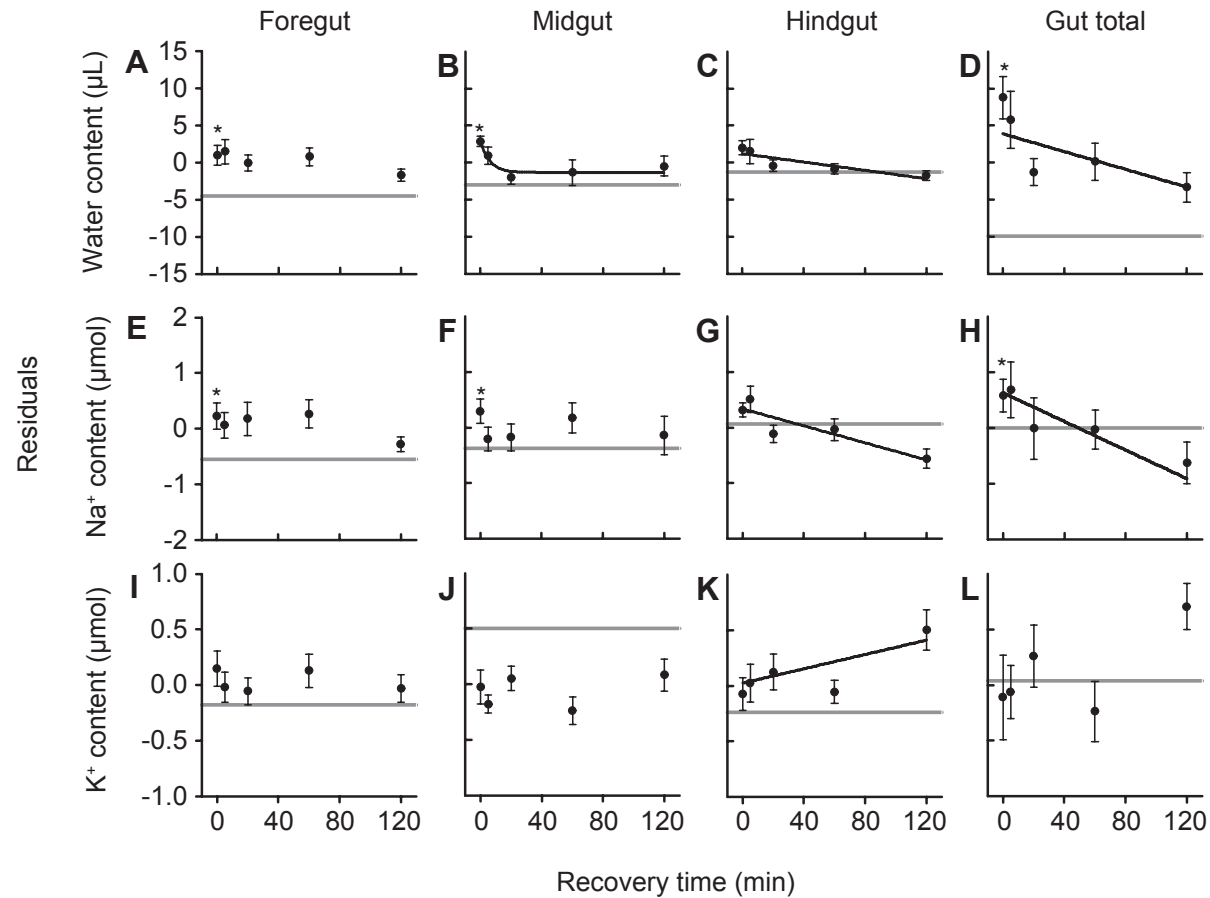

Figure B.2. Residual water (A-D), Na⁺ (E-H), and K⁺ (I-L) content of each of the three gut segments and total gut of crickets during chill-coma recovery at 22 °C following 24 h at 0 °C. Solid black lines indicate a significant relationship between recovery time and gut volume or ion content. Grey lines indicate means of control crickets (those that did not receive any cold exposure). Stars denote a significant effect of cold exposure on ion concentration or content.

Video B.1. Example video recording of a cricket ($8 \times$ speed) inside the respirometry chamber with accompanying $\dot{V}CO_2$ trace (top left panel) during chill-coma recovery at $22^\circ C$ following 16 h at $0^\circ C$. The activity detector was removed to enable video recording. Three 10 minute periods are shown in sequence, with the time-matched $\dot{V}CO_2$ trace shown in detail (top right panel): 1) As metabolic rate peaks early in the overshoot, there is minimal movement of the cricket inside the chamber, demonstrating that the overshoot is not simply a product of cricket activity during recovery. 2) Later in the overshoot the cricket has a high and variable $\dot{V}CO_2$ that was often associated with high apparent activity in crickets measured using the activity detector. From this video it is clear that this activity is modest, and in the form of abdominal contractions that may serve to supply oxygen and expel CO_2 more effectively during a period of high metabolic demand and/or actively mix the hemolymph, the composition of which is changing. 3) Once the overshoot is complete, true periods of high activity (such as attempts by the cricket to turn around in the chamber) cause deviations in $\dot{V}CO_2$ that are small and fleeting relative to the overshoot.

Appendix C: Chapter 6 supplementary material

Supplementary methods

Hemolymph collection

Adult *Drosophila* were positioned for hemolymph sampling using a custom made apparatus (Figure C.1A). A device composed of four three-way stopcocks and rubber tubing was attached to a standard 35 mL *Drosophila* rearing vial and pressure was supplied from a laboratory air supply. A staging area was created by adding a barrier in the tube made of a small piece of cheesecloth (Figure C.1A). A 10- μ L pipette tip was attached to the end of the device and positioned on a microscope stage. The stopcocks were set such that air-flow was directed through the *Drosophila* vial where a single fly was picked up by the air current and directed into the staging area (Figure C.1B). Once a fly was isolated in the staging area, the stopcock settings were changed, such that air-flow was directed through the cheesecloth in the opposite direction to move the fly into the pipette tip (Figure C.1C). Air pressure was applied until the fly was restrained by the diameter of the tip, and stopped before the fly was injured (Figure C.1D). The space remaining at the end of the pipette tip was cut using a razor, and air pressure was applied until one or both antennae protruded from the tip (Figure C.1D). An antenna was amputated at its first segment and a clear droplet of hemolymph was secreted (Figure C.1E). The pipette tip, with the fly and droplet attached, were immediately removed from the rest of the device and the droplet was placed under hydrated paraffin oil for measurement of $[\text{Na}^+]$ and $[\text{K}^+]$ concentrations by the ion selective microelectrode technique (Section 6.2.3).

Measurement of Na^+/K^+ -ATPase activity

Maximal activity of Na^+/K^+ -ATPase was measured across a range of temperatures using a thermally dynamic, NADH-linked, spectrophotometric assay (Section 6.2.4.1). Four replicate cuvettes of each *Drosophila* sample were run, two of which contained 1 mM ouabain (a specific inhibitor of Na^+/K^+ -ATPase). Temperature inside a dummy cuvette was monitored by a ceramic temperature probe (Agilent Technologies) interfaced with

the spectrophotometer, which controlled the rate of temperature change. A type-T thermocouple was also suspended in the dummy cuvette and connected to a TC-08 interface (Pico Technology, St. Neots), which allowed measured the temperature inside the cuvette every second for the duration of each sample run. The rate of temperature change inside the cuvette was consistent throughout the temperature ramp (Figure C.2A). Activity of Na^+/K^+ -ATPase was determined as the difference between the smoothed rates of cuvettes containing 1 mM ouabain and cuvettes that did not contain ouabain (Figure C.2B).

The activity of Na^+/K^+ -ATPase was also measured at five static temperatures (6, 11, 13.3, 17.6, and 21.5 °C) in $n=4$ samples of male *Drosophila melanogaster* acclimated to 21.5 °C (Figure C.2C). The methods of sample preparation and the final assay conditions for the static-temperature Na^+/K^+ -ATPase assays were identical those used for the thermally-dynamic assay (Section 6.2.4.1). Once temperature inside the dummy cuvette was stable at the set temperature (as determined by the type-T thermocouple), the reaction was initiated by the addition of ATP as in the thermally dynamic assay. Rates of Na^+/K^+ -ATPase activity in OD min^{-1} over a 10 min period of recording were converted to mol ATP consumed min^{-1} using the Beer-Lambert law. Static and dynamic methods of the Na^+/K^+ -ATPase assay yielded similar estimates of Na^+/K^+ -ATPase activity in male *D. melanogaster* acclimated to 21.5 °C (Figure C.2C).

Figure C.1. Schematic of the apparatus used to collect hemolymph from *Drosophila* without anesthesia. (A) A device composed of four three-way stopcocks (1-4) and rubber tubing is attached to a standard 35 mL *Drosophila* rearing vial and a laboratory air supply. Stopcock 1 serves as a master air-flow vent. Stopcocks 2-4 direct air flow through the apparatus. A 10- μ L pipette tip is attached to the end of stopcock 4. (B) By setting the stopcocks as shown (direction of arm points to the off position) air flow (dark grey) is directed through the vial where a single fly is picked up and directed into the staging area. (C) The stopcock settings are then changed, such that air-flow directs the fly into the pipette tip. Air pressure is applied until the fly is restrained by the diameter of the tip. The end of the pipette tip is removed using a razor, and air pressure is applied until one or both antennae protrude from the tip (D). An antenna is amputated at its first segment and a droplet of hemolymph is secreted (E).

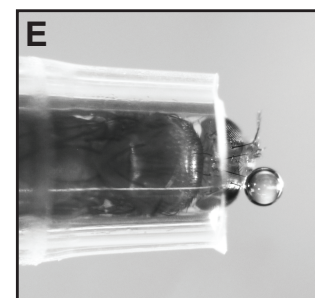
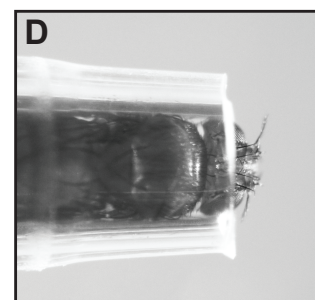
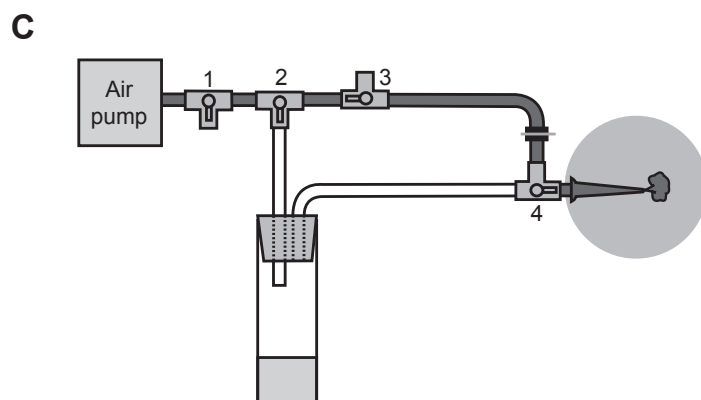
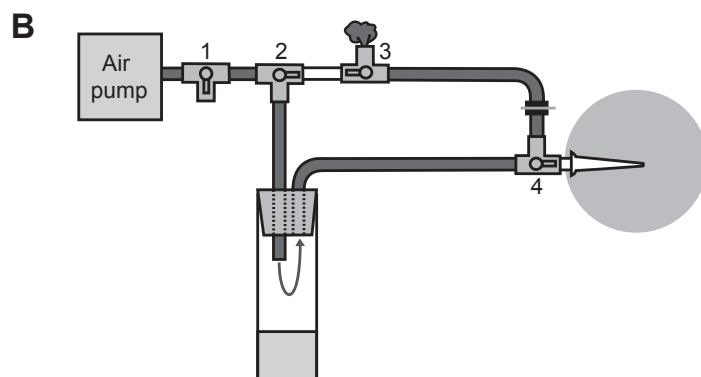
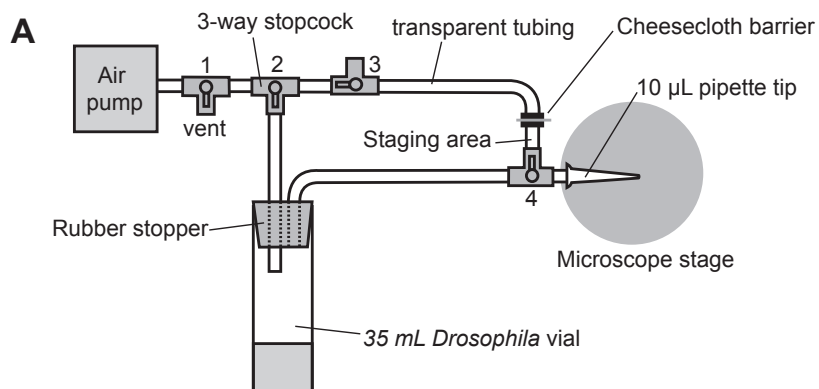

Figure C.2. Na⁺/K⁺-ATPase activity recorded using a temperature ramp and comparison to activity measured at static temperatures. (A) Temperature of a dummy sample recorded by a type T-thermocouple held inside a cuvette during a Na⁺/K⁺-ATPase activity sample run. Temperature ramps accomplished by the spectrophotometer were highly linear, allowing for accurate calculation of reaction rates with temperature. (B) Reaction rates measured using a dynamic ramping technique (grey points) were smoothed using a sliding window method (grey lines) before rates of ouabain-inhibited samples were subtracted from the same samples without ouabain to yield activity of Na⁺/K⁺-ATPase (black line). (C) Comparison of Na⁺/K⁺-ATPase rates measured using the ramping technique (black lines) to activity measured at static temperatures (grey points). Dynamically ramped samples are expressed as a mean rate \pm 95 % CI determined from logistic fits of $n=6$ samples. Static temperature data is expressed as mean \pm sem of $n=4$ samples at each temperature.

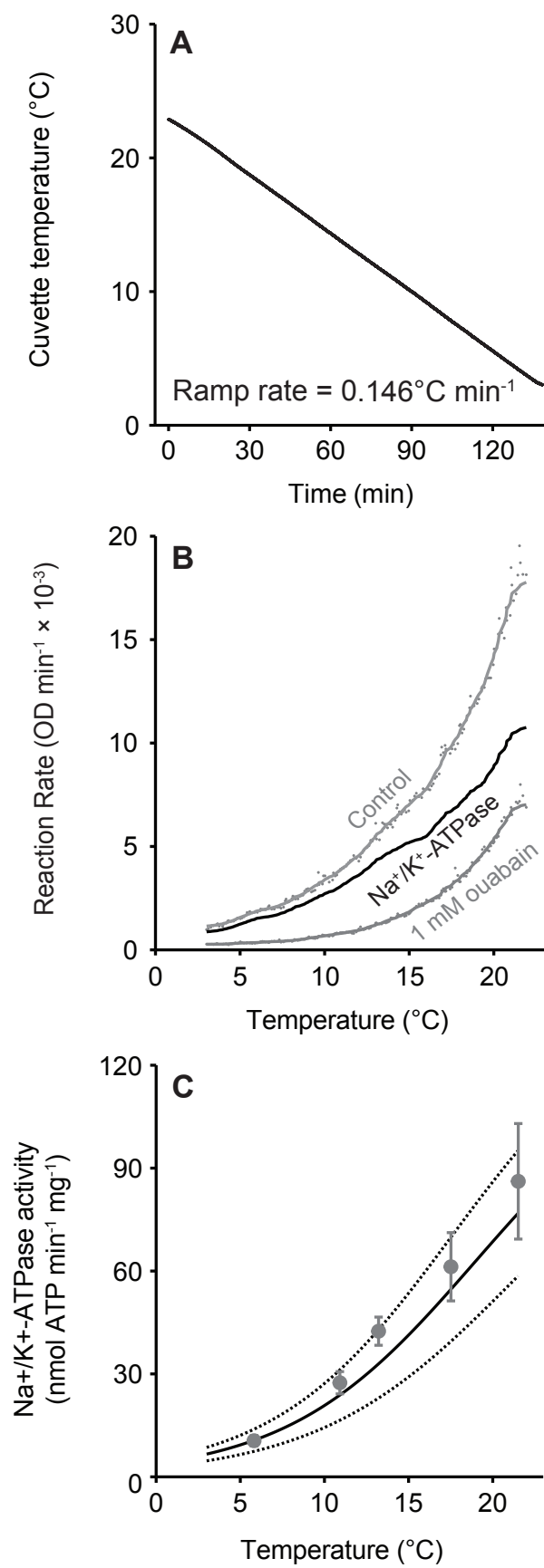

Table C.1. Details of *Drosophila* species stock origins and critical thermal minima estimates. The majority of species were obtained from the UC San Diego and Ehime University *Drosophila* stock centers. Species names in bold have had their genome sequenced as part of the *Drosophila* 12 genomes project. Stars denote the line is the same as was used for genome sequencing.

Species	Source ¹	Stock No.	Origin Location	Collection Date
<i>D. algonquin</i>	UCSD	14012-0161.03	Rocky Point, New York, USA	2004
<i>D. ananassae</i>	EU	E-11002	Kagoshima, Japan	2001
<i>D. arawakana</i>	UCSD	15182-2261.03	Monkey Hill, St. Kitts, Caribbean	2005
<i>D. auraria</i>	EU	E-11220	Hokkaido, Japan	2004
<i>D. borealis</i>	UCSD	15010-0961.05	Lytton, Quebec, Canada	1949
<i>D. erecta</i> *	UCSD	14021-0224.01	Unknown	Prior to 1977
<i>D. funebris</i>	EU	E-13501	Hokkaido, Japan	1987
<i>D. hydei</i>	Field	NA	London, Ontario, Canada	2007
<i>D. immigrans</i>	UCSD	15111-1731.03	Patan, Nepal	Prior to 1977
<i>D. kanekoi</i>	EU	E-13901	Hokkaido, Japan	1987
<i>D. mauritiana</i>	AM	NA	Mauritius	1981
<i>D. melanogaster</i>	Field	NA	London, Ontario, Canada	2007
<i>D. mercatorum</i>	UCSD	15082-1521.25	Argoim, Bahia, Brazil	1976
<i>D. mojavensis</i> *	UCSD	15081-1352.22	Santa Catalina Island, California,	2002
<i>D. nepalensis</i>	RP	NA	Shimla, India	2004
<i>D. obscura</i>	UCSD	14011-0151.00	Heidelberg, Germany	2005
<i>D. persimilis</i> *	UCSD	14011-0111.49	Mount St. Helena, California,	1997
<i>D.</i>	UCSD	14011-0121.94	Mesa Verde, Colorado, USA	1996
<i>D. sechellia</i> *	UCSD	14021-0248.25	Cousin Island, Seychelles	1980
<i>D. takahashii</i>	EU	E-12201	Okinawa, Japan	2002
<i>D. triauraria</i>	UCSD	14028-0691.01	Meguro, Tokyo, Japan	Unknown
<i>D. virilis</i>	EU	E-15601	Hokkaido, Japan	1985
<i>D. willistoni</i> *	UCSD	14030-0811.24	Guadeloupe island, France	Unknown
<i>D. yakuba</i> *	UCSD	14021-0261.01	Between Liberia and Ivory Coast	1983

1. UCSD: University of California San Diego Stock Center; EU: Ehime University Stock Center; Field: Field collected; AM: Dr. Amanda Mohering, Western University; RP: Dr. Ravi Parkash, Maharshi Dayanand University, India.

Table C.2. Summary of physiological variables measured in *Drosophila* species (mean \pm sem). Some variables were not measured (*nm*) in some species as a result of logistical constraints (see section 6.2 for details). CT_{\min} is the temperature at which 80 % of flies fell from the column based on accelerated failure time models (section 6.2.8). Maximal rate of Na^+/K^+ -ATPase (V_{\max}) at 21.5 °C is expressed as $nmol\ ATP\ min^{-1}\ mg^{-1}$.

Species	CT_{\min} (°C)	Hemolymph [ion] (mM)		Na ⁺ /K ⁺ -ATPase		
		[Na ⁺]	[K ⁺]	V_{\max} at 21.5°C	IP (°C)	T_s
<i>D. algonquin</i>	-1.79 \pm 0.08	<i>nm</i>	<i>nm</i>	50.3 \pm 7.1	23.9 \pm 4.0	6.20 \pm 0.53
<i>D. ananassae</i>	7.36 \pm 0.04	99.5 \pm 2.2	35.5 \pm 4.3	62.8 \pm 7.5	18.1 \pm 2.2	4.49 \pm 0.57
<i>D. arawakana</i>	7.30 \pm 0.08	111.2 \pm 16.9	27.2 \pm 2.2	<i>nm</i>	<i>nm</i>	<i>nm</i>
<i>D. auraria</i>	2.45 \pm 0.07	85.6 \pm 1.8	16.8 \pm 1.3	28.4 \pm 5.9	14.4 \pm 0.9	4.06 \pm 0.29
<i>D. borealis</i>	-2.90 \pm 0.09	119.7 \pm 5.8	17.7 \pm 2.6	25.9 \pm 5.2	16.5 \pm 2.5	4.04 \pm 0.67
<i>D. erecta</i>	7.17 \pm 0.07	85.6 \pm 1.8	23.2 \pm 1.9	64.5 \pm 9.8	18.8 \pm 1.5	4.53 \pm 0.44
<i>D. funebris</i>	1.36 \pm 0.09	119.3 \pm 14.0	17.8 \pm 2.6	14.4 \pm 1.7	18.2 \pm 4.9	4.82 \pm 1.11
<i>D. hydei</i>	1.38 \pm 0.07	81.5 \pm 7.7	20.1 \pm 1.5	33.5 \pm 6.4	18.4 \pm 2.0	4.35 \pm 0.85
<i>D. immigrans</i>	8.17 \pm 0.08	89.0 \pm 9.6	33.7 \pm 5.4	23.5 \pm 3.3	18.9 \pm 2.0	4.55 \pm 0.27
<i>D. kanekoi</i>	-1.40 \pm 0.08	<i>nm</i>	<i>nm</i>	17.4 \pm 2.6	19.3 \pm 3.2	4.40 \pm 0.94
<i>D. mauritiana</i>	2.55 \pm 0.05	106.8 \pm 14.4	21.2 \pm 0.8	50.4 \pm 10.1	18.3 \pm 0.8	4.86 \pm 0.40
<i>D. melanogaster</i>	1.81 \pm 0.07	125.8 \pm 10.7	21.6 \pm 2.7	68.9 \pm 12.6	18.5 \pm 1.6	4.05 \pm 0.76
<i>D. mercatorum</i>	4.57 \pm 0.06	89.8 \pm 2.5	19.8 \pm 1.6	26.3 \pm 6.4	24.3 \pm 4.8	6.10 \pm 0.90
<i>D. mojavensis</i>	2.75 \pm 0.08	124.9 \pm 4.8	19.7 \pm 1.6	24.8 \pm 1.6	23.4 \pm 4.5	5.98 \pm 0.37
<i>D. nepalensis</i>	3.82 \pm 0.09	95.6 \pm 3.4	29.6 \pm 2.6	57.4 \pm 20.2	22.8 \pm 3.1	4.81 \pm 0.96
<i>D. obscura</i>	-1.69 \pm 0.09	93.1 \pm 0.1	21.2 \pm 2.6	53.9 \pm 8.6	18.6 \pm 1.9	4.76 \pm 0.40
<i>D. persimilis</i>	0.16 \pm 0.10	123.1 \pm 10.3	19.3 \pm 1.0	46.1 \pm 7.1	18.8 \pm 2.7	4.95 \pm 0.63
<i>D. pseudoobscura</i>	-0.67 \pm 0.10	101.8 \pm 11.7	19.2 \pm 2.5	48.6 \pm 8.7	18.4 \pm 1.1	4.94 \pm 0.20
<i>D. sechellia</i>	7.00 \pm 0.07	154.1 \pm 6.7	28.7 \pm 3.2	45.1 \pm 2.0	26.0 \pm 2.4	6.51 \pm 0.60
<i>D. takahashii</i>	6.50 \pm 0.04	124.4 \pm 11.0	28.0 \pm 6.4	63.2 \pm 12.8	21.7 \pm 1.9	5.55 \pm 0.45
<i>D. triauraria</i>	1.95 \pm 0.10	130.5 \pm 9.4	20.5 \pm 2.7	41.8 \pm 2.3	24.0 \pm 4.8	5.75 \pm 0.66
<i>D. virilis</i>	-0.49 \pm 0.07	70.8 \pm 3.3	19.6 \pm 2.6	25.8 \pm 5.2	19.3 \pm 1.5	4.72 \pm 0.23
<i>D. willistoni</i>	7.88 \pm 0.06	121.6 \pm 9.4	37.6 \pm 2.8	37.0 \pm 5.3	16.9 \pm 1.4	4.74 \pm 0.38
<i>D. yakuba</i>	6.02 \pm 0.05	108.9 \pm 1.2	16.9 \pm 1.5	75.4 \pm 13.1	23.0 \pm 3.9	5.47 \pm 0.80

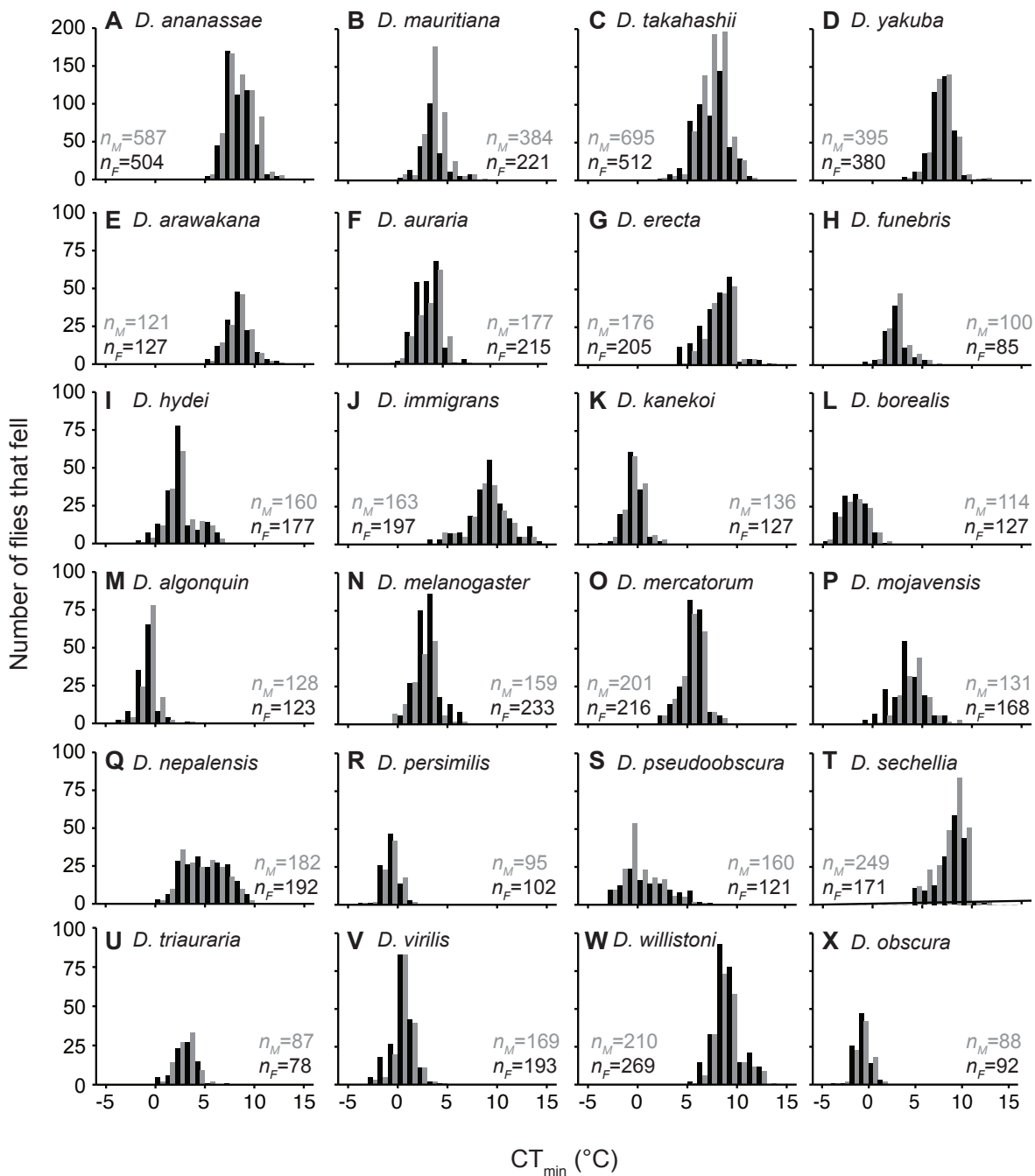

Figure C.3. Histograms of critical thermal minima of female (black bars) and male (grey bars) flies of the genus *Drosophila*. Critical thermal minimum (CT_{\min}) data were obtained by exposing flies to a temperature ramp at $-0.1\text{ }^{\circ}C\text{ min}^{-1}$ in a temperature controlled column, and were collected and counted in $1^{\circ}C$ intervals (see 6.2.2 for details). n_M : sample size of male flies; n_F : sample size of female flies.

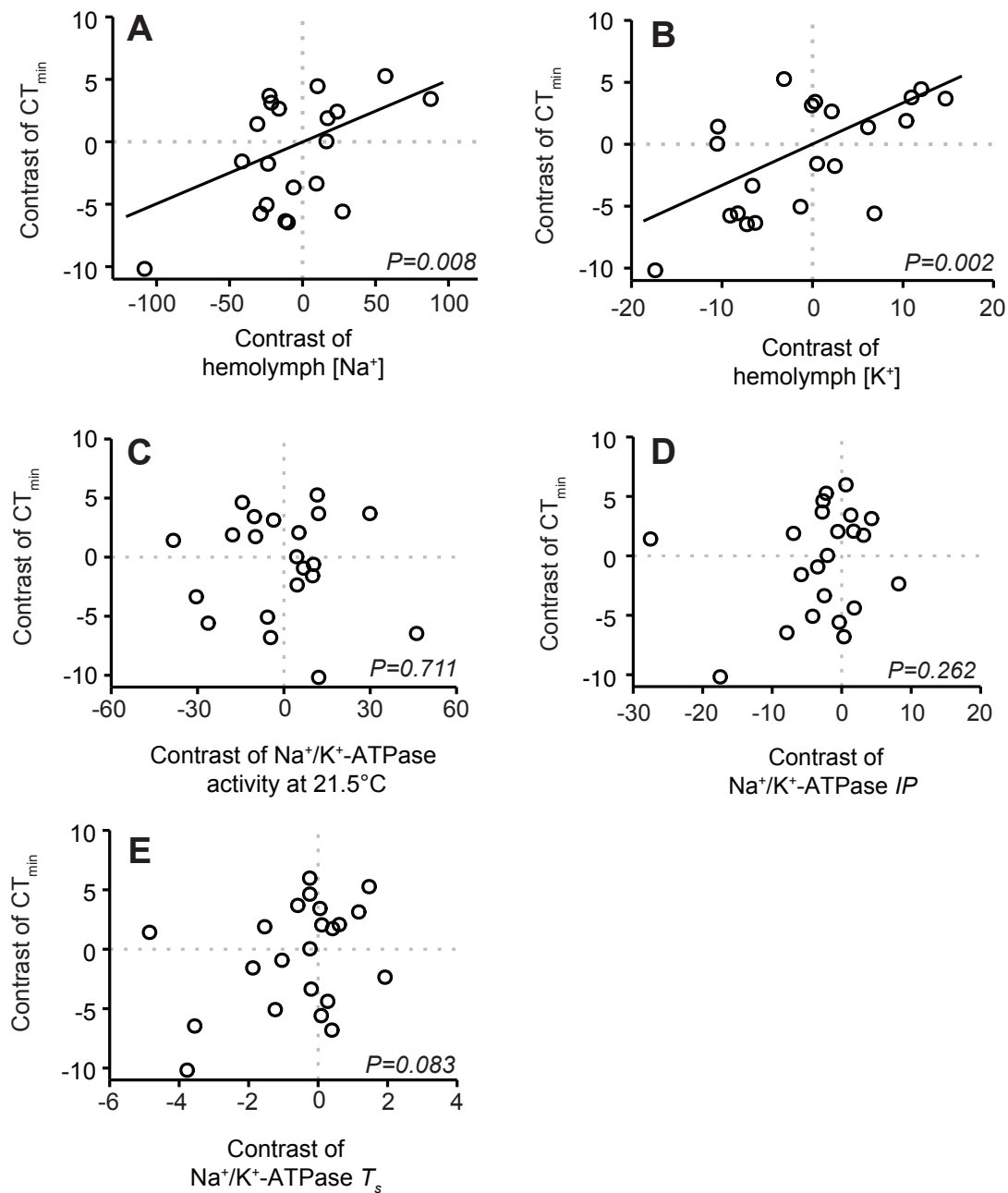

Figure C.4. Phylogenetically-independent contrasts (PICs) of the critical thermal minimum (CT_{min}) regressed against hemolymph ion concentrations (A,B) and Na^+/K^+ -ATPase parameters (C-E; see 6.2.6). P -values were obtained from linear regressions of PIC data forced through the origin (dotted grey lines). Solid black lines denote a significant relationship between the PICs of ion concentration and CT_{min} . T_s : thermal sensitivity; IP : inflection point.

Appendix D: Reprint permissions

Reprint permission for chapter 2

This is a License Agreement between Heath A MacMillan ("You") and Elsevier ("Elsevier") provided by Copyright Clearance Center ("CCC"). The license consists of your order details, the terms and conditions provided by Elsevier, and the payment terms and conditions.

All payments must be made in full to CCC. For payment instructions, please see information listed at the bottom of this form.

Supplier	Elsevier Limited
Registered Company Number	1982084
Customer name	Heath A MacMillan
Customer address	Department of Biology London, ON N6A 5B7
License number	3093731454727
License date	Feb 21, 2013
Licensed content publisher	Elsevier
Licensed content publication	Journal of Insect Physiology
Licensed content title	Mechanisms underlying insect chill-coma
Licensed content author	Heath A. MacMillan, Brent J. Sinclair
Licensed content date	January 2011
Licensed content volume number	57
Licensed content issue number	1
Number of pages	9
Start Page	12
End Page	20
Type of Use	reuse in a thesis/dissertation
Portion	full article
Format	both print and electronic
Are you the author of this Elsevier article?	Yes
Will you be translating?	No
Title of your thesis/dissertation	The ionic and osmotic nature of insect chill-coma and chilling injury
Expected completion date	Aug 2013
Estimated size (number of pages)	200
Elsevier VAT number	GB 494 6272 12
Permissions price	0.00 USD

VAT/Local Sales Tax	0.0 USD / 0.0 GBP
Total	0.00 USD

Terms and Conditions

INTRODUCTION

1. The publisher for this copyrighted material is Elsevier. By clicking "accept" in connection with completing this licensing transaction, you agree that the following terms and conditions apply to this transaction (along with the Billing and Payment terms and conditions established by Copyright Clearance Center, Inc. ("CCC"), at the time that you opened your Rightslink account and that are available at any time at <http://myaccount.copyright.com>).

GENERAL TERMS

2. Elsevier hereby grants you permission to reproduce the aforementioned material subject to the terms and conditions indicated.

3. Acknowledgement: If any part of the material to be used (for example, figures) has appeared in our publication with credit or acknowledgement to another source, permission must also be sought from that source. If such permission is not obtained then that material may not be included in your publication/copies. Suitable acknowledgement to the source must be made, either as a footnote or in a reference list at the end of your publication, as follows:
 “Reprinted from Publication title, Vol /edition number, Author(s), Title of article / title of chapter, Pages No., Copyright (Year), with permission from Elsevier [OR APPLICABLE SOCIETY COPYRIGHT OWNER].” Also Lancet special credit - “Reprinted from The Lancet, Vol. number, Author(s), Title of article, Pages No., Copyright (Year), with permission from Elsevier.”

4. Reproduction of this material is confined to the purpose and/or media for which permission is hereby given.

5. Altering/Modifying Material: Not Permitted. However figures and illustrations may be altered/adapted minimally to serve your work. Any other abbreviations, additions, deletions and/or any other alterations shall be made only with prior written authorization of Elsevier Ltd. (Please contact Elsevier at permissions@elsevier.com)

6. If the permission fee for the requested use of our material is waived in this instance, please be advised that your future requests for Elsevier materials may attract a fee.

7. Reservation of Rights: Publisher reserves all rights not specifically granted in the combination of (i) the license details provided by you and accepted in the course of this licensing transaction, (ii) these terms and conditions and (iii) CCC's Billing and Payment terms and conditions.

8. License Contingent Upon Payment: While you may exercise the rights licensed immediately upon issuance of the license at the end of the licensing process for the transaction, provided that

you have disclosed complete and accurate details of your proposed use, no license is finally effective unless and until full payment is received from you (either by publisher or by CCC) as provided in CCC's Billing and Payment terms and conditions. If full payment is not received on a timely basis, then any license preliminarily granted shall be deemed automatically revoked and shall be void as if never granted. Further, in the event that you breach any of these terms and conditions or any of CCC's Billing and Payment terms and conditions, the license is automatically revoked and shall be void as if never granted. Use of materials as described in a revoked license, as well as any use of the materials beyond the scope of an unrevoked license, may constitute copyright infringement and publisher reserves the right to take any and all action to protect its copyright in the materials.

9. **Warranties:** Publisher makes no representations or warranties with respect to the licensed material.

10. **Indemnity:** You hereby indemnify and agree to hold harmless publisher and CCC, and their respective officers, directors, employees and agents, from and against any and all claims arising out of your use of the licensed material other than as specifically authorized pursuant to this license.

11. **No Transfer of License:** This license is personal to you and may not be sublicensed, assigned, or transferred by you to any other person without publisher's written permission.

12. **No Amendment Except in Writing:** This license may not be amended except in a writing signed by both parties (or, in the case of publisher, by CCC on publisher's behalf).

13. **Objection to Contrary Terms:** Publisher hereby objects to any terms contained in any purchase order, acknowledgment, check endorsement or other writing prepared by you, which terms are inconsistent with these terms and conditions or CCC's Billing and Payment terms and conditions. These terms and conditions, together with CCC's Billing and Payment terms and conditions (which are incorporated herein), comprise the entire agreement between you and publisher (and CCC) concerning this licensing transaction. In the event of any conflict between your obligations established by these terms and conditions and those established by CCC's Billing and Payment terms and conditions, these terms and conditions shall control.

14. **Revocation:** Elsevier or Copyright Clearance Center may deny the permissions described in this License at their sole discretion, for any reason or no reason, with a full refund payable to you. Notice of such denial will be made using the contact information provided by you. Failure to receive such notice will not alter or invalidate the denial. In no event will Elsevier or Copyright Clearance Center be responsible or liable for any costs, expenses or damage incurred by you as a result of a denial of your permission request, other than a refund of the amount(s) paid by you to Elsevier and/or Copyright Clearance Center for denied permissions.

LIMITED LICENSE

The following terms and conditions apply only to specific license types:

15. **Translation:** This permission is granted for non-exclusive world **English** rights only unless

your license was granted for translation rights. If you licensed translation rights you may only translate this content into the languages you requested. A professional translator must perform all translations and reproduce the content word for word preserving the integrity of the article. If this license is to re-use 1 or 2 figures then permission is granted for non-exclusive world rights in all languages.

16. **Website:** The following terms and conditions apply to electronic reserve and author websites:

Electronic reserve: If licensed material is to be posted to website, the web site is to be password-protected and made available only to bona fide students registered on a relevant course if:

This license was made in connection with a course,

This permission is granted for 1 year only. You may obtain a license for future website posting, All content posted to the web site must maintain the copyright information line on the bottom of each image,

A hyper-text must be included to the Homepage of the journal from which you are licensing at <http://www.sciencedirect.com/science/journal/xxxxx> or the Elsevier homepage for books at <http://www.elsevier.com> , and

Central Storage: This license does not include permission for a scanned version of the material to be stored in a central repository such as that provided by Heron/XanEdu.

17. **Author website** for journals with the following additional clauses:

All content posted to the web site must maintain the copyright information line on the bottom of each image, and the permission granted is limited to the personal version of your paper. You are not allowed to download and post the published electronic version of your article (whether PDF or HTML, proof or final version), nor may you scan the printed edition to create an electronic version. A hyper-text must be included to the Homepage of the journal from which you are licensing at <http://www.sciencedirect.com/science/journal/xxxxx> . As part of our normal production process, you will receive an e-mail notice when your article appears on Elsevier's online service ScienceDirect (www.sciencedirect.com). That e-mail will include the article's Digital Object Identifier (DOI). This number provides the electronic link to the published article and should be included in the posting of your personal version. We ask that you wait until you receive this e-mail and have the DOI to do any posting.

Central Storage: This license does not include permission for a scanned version of the material to be stored in a central repository such as that provided by Heron/XanEdu.

18. **Author website** for books with the following additional clauses:

Authors are permitted to place a brief summary of their work online only.

A hyper-text must be included to the Elsevier homepage at <http://www.elsevier.com> . All content posted to the web site must maintain the copyright information line on the bottom of each image. You are not allowed to download and post the published electronic version of your chapter, nor may you scan the printed edition to create an electronic version.

Central Storage: This license does not include permission for a scanned version of the material to be stored in a central repository such as that provided by Heron/XanEdu.

19. **Website** (regular and for author): A hyper-text must be included to the Homepage of the journal from which you are licensing at <http://www.sciencedirect.com/science/journal/xxxxx>. or for books to the Elsevier homepage at <http://www.elsevier.com>

20. **Thesis/Dissertation**: If your license is for use in a thesis/dissertation your thesis may be submitted to your institution in either print or electronic form. Should your thesis be published commercially, please reapply for permission. These requirements include permission for the Library and Archives of Canada to supply single copies, on demand, of the complete thesis and include permission for UMI to supply single copies, on demand, of the complete thesis. Should your thesis be published commercially, please reapply for permission.

Reprint permission for chapters 3 and 4

Excerpt from: http://jeb.biologists.org/site/journal/rights_permissions.xhtml

Accessed: May 5, 2013, 15:07 EST

Author rights

Authors remain the owners of the copyright to the article and retain the following non-exclusive rights (for further details, please refer to the licence agreement that accompanies article proofs):

(1) authors may reproduce the article, in whole or in part, in any printed book (including thesis) of which they are author, provided the original article is properly and fully attributed;

(2) authors and any academic institution where they are employed may reproduce the article, in whole or in part, for the purpose of teaching students;

(3) authors may post a copy of the article on their website, provided that it has already been published by the journal and is linked to the journal's website at <http://jeb.biologists.org>;

(4) authors may use data contained in the article in other works they create;

Copyright and reproduction

Articles in JEB are published under an exclusive, worldwide licence granted to the publisher by the authors, who retain copyright. For full details of Open Access article use, see [Open Access rights](#) above.

Permission to use material from JEB in other publications

Authors are free to reproduce material from their own articles in other publications. Other individuals must first seek permission from The Company of Biologists to reproduce material by sending an email to permissions@biologists.com.

Reprint permission for chapter 5

Excerpt from: <http://www.pnas.org/site/aboutpnas/rightperm.xhtml>

Accessed: April 25, 2013, 07:35 EST

Anyone may, without requesting permission, use original figures or tables published in PNAS for noncommercial and educational use (i.e., in a review article, in a book that is not for sale) provided that the original source and the applicable copyright notice are cited.

PNAS authors need not obtain permission for the following cases: (1) to use their original figures or tables in their future works; (2) to make copies of their papers for their own personal use, including classroom use, or for the personal use of colleagues, provided those copies are not for sale and are not distributed in a systematic way; (3) **to include their papers as part of their dissertations;** or (4) to use all or part of their articles in printed compilations of their own works. Citation of the original source must be included and copies must include the applicable copyright notice of the original report.

Authors whose work will be reused should be notified. PNAS cannot supply original artwork. Use of PNAS material must not imply any endorsement by PNAS or the National Academy of Sciences. The full journal reference must be cited and, for articles published in Volumes 90–105 (1993–2008), "Copyright (copyright year) National Academy of Sciences, USA."

Curriculum vitae

Name: Heath A. MacMillan

Post-secondary Education and Degrees: University of Western Ontario
London, Ontario, Canada
2008-2013 Ph.D.

University of Western Ontario
London, Ontario, Canada
2004-2008 B.Sc.

Selected Honours and Awards Society for Experimental Biology Graduate Travel Award, 2012
Alexander Graham Bell Canada Graduate Scholarship, 2010
Ontario Graduate Scholarship, 2009
NSERC Undergraduate Student Research Award, 2007

Related Work Experience Teaching Assistant
The University of Western Ontario
2008-2012

Publications:

A total of 13 publications in peer reviewed journals.

Lake, S.A., **MacMillan, H.A.**, Williams, C.M., Sinclair, B.J. (in press) Static and dynamic approaches yield similar estimates of thermal sensitivity of insect metabolism. *Journal of Insect Physiology*.

Sinclair, B.J., Ferguson, L., Salehipourshirazi, G., **MacMillan, H.A.** (in press) Cross-tolerance and cross-talk in the cold: relating low temperatures to desiccation and immune stress in insects. *Integrative and Comparative Biology*.

Sinclair, B.J., Stinziano, J.R., Williams, C.M., **MacMillan, H.A.**, Marshall, K.E., Storey, K.B. (2013) Real-time measurement of metabolic rate during freezing and thawing of the wood frog, *Rana sylvatica*: Implications for overwinter energy use. *The Journal of Experimental Biology* 216, 292-302.

MacMillan, H.A., Williams, C.M., Staples, J.F., Sinclair, B.J. (2012) Reestablishment of ion homeostasis during chill-coma recovery in the cricket *Gryllus pennsylvanicus*. *Proceedings of the National Academy of Sciences USA* 109, 20750-20755.

- MacMillan, H.A.**, Williams, C.M., Staples, J.F., Sinclair, B.J. (2012) Metabolism and energy supply below the critical thermal minimum of a chill-susceptible insect. *The Journal of Experimental Biology* 215, 1366-1372.
- Williams, C.M., Marshall, K.E. **MacMillan, H.A.**, Dzurisin, J.D.K., Hellmann, J.J., Sinclair, B.J. (2012) Thermal variability increases the impact of autumnal warming and drives metabolic depression in an overwintering butterfly. *PLoS ONE* 7, e34470.
- MacMillan, H.A.**, Sinclair, B.J. (2011) The role of the gut in insect chilling-injury: cold-induced disruption of osmoregulation in the fall field cricket, *Gryllus pennsylvanicus*. *The Journal of Experimental Biology* 214, 726-734.
- MacMillan, H.A.**, Sinclair, B.J. (2011) Mechanisms underlying insect chill-coma. *Journal of Insect Physiology* 57, 12-20.
- Ransberry, V.E., **MacMillan, H.A.**, Sinclair, B.J. (2011) The relationship between chill-coma onset and recovery at the extremes of the thermal window of *Drosophila melanogaster*. *Physiological and Biochemical Zoology* 84, 553-559.
- Williams, C.M., Thomas, R.H., **MacMillan, H.A.**, Marshall, K.E., Sinclair, B.J. (2011) Triglyceride measurement in small quantities of insect tissue: comparisons and caveats. *Journal of Insect Physiology* 57, 1602-1613.
- Bazinet, A.L., Marshall, K.E., **MacMillan, H.A.**, Williams, C.M., Sinclair, B.J. (2010) Rapid changes in desiccation resistance in *Drosophila melanogaster* are facilitated by changes in cuticular permeability. *Journal of Insect Physiology* 56, 2006-2012.
- MacMillan, H.A.**, Guglielmo, C.G., Sinclair, B.J. (2009) Membrane remodeling and glucose in *Drosophila melanogaster*: a test of rapid cold-hardening and chilling tolerance hypotheses. *Journal of Insect Physiology* 55, 243-249.
- MacMillan, H.A.**, Walsh, J.P., Sinclair B.J. (2009) The effects of selection for cold tolerance on cross-tolerance to other environmental stressors in *Drosophila melanogaster* Meigen. *Insect Science* 16, 263-276.