

Electronic Thesis and Dissertation Repository

---

6-14-2011 12:00 AM

## The Effects of Superovulation and Embryo Culture on Genomic Imprinting in a Mouse Model System

Brenna A. M. Velker  
*The University of Western Ontario*

Supervisor  
Dr. Mellissa Mann  
*The University of Western Ontario*

Graduate Program in Biochemistry  
A thesis submitted in partial fulfillment of the requirements for the degree in Doctor of Philosophy  
© Brenna A. M. Velker 2011

Follow this and additional works at: <https://ir.lib.uwo.ca/etd>



Part of the [Developmental Biology Commons](#)

---

### Recommended Citation

Velker, Brenna A. M., "The Effects of Superovulation and Embryo Culture on Genomic Imprinting in a Mouse Model System" (2011). *Electronic Thesis and Dissertation Repository*. 177.  
<https://ir.lib.uwo.ca/etd/177>

This Dissertation/Thesis is brought to you for free and open access by Scholarship@Western. It has been accepted for inclusion in Electronic Thesis and Dissertation Repository by an authorized administrator of Scholarship@Western. For more information, please contact [wlsadmin@uwo.ca](mailto:wlsadmin@uwo.ca).

THE EFFECTS OF SUPEROVULATION AND EMBRYO CULTURE ON GENOMIC  
IMPRINTING IN A MOUSE MODEL SYSTEM

(Spine title: Genomic Imprinting and ARTs)

(Thesis format: Integrated-Article)

by

Brenna A. M. Velker

Graduate Program in Biochemistry

A thesis submitted in partial fulfillment  
of the requirements for the degree of  
Doctor of Philosophy

The School of Graduate and Postdoctoral Studies  
The University of Western Ontario  
London, Ontario, Canada

© Brenna A. M. Velker 2011

THE UNIVERSITY OF WESTERN ONTARIO  
SCHOOL OF GRADUATE AND POSTDOCTORAL STUDIES

**CERTIFICATE OF EXAMINATION**

Supervisor

\_\_\_\_\_  
Dr. Mellissa Mann

Co-Supervisor

\_\_\_\_\_  
Dr. Andrew Watson

Supervisory Committee

\_\_\_\_\_  
Dr. Nathalie Berube

\_\_\_\_\_  
Dr. Victor Han

Examiners

\_\_\_\_\_  
Dr. Bonnie Deroo

\_\_\_\_\_  
Dr. David Rodenhiser

\_\_\_\_\_  
Dr. Timothy Regnault

\_\_\_\_\_  
Dr. Marc-Andre Sirard

The thesis by

**Brenna A. M. Velker**

entitled:

**The Effects of Superovulation and Embryo Culture on Genomic  
Imprinting in a Mouse Model System**

is accepted in partial fulfillment of the  
requirements for the degree of  
Doctor of Philosophy

Date \_\_\_\_\_

\_\_\_\_\_  
Chair of the Thesis Examination Board

## **ABSTRACT**

Genomic imprinting is a specialized transcriptional mechanism resulting in the unequal expression of alleles based on their parent-of-origin. Imprinted genes are critical for embryonic and fetal development and their dysregulation is linked to a group of human diseases called imprinting disorders, including Beckwith-Wiedemann Syndrome, Angelman Syndrome and Silver-Russell Syndrome. Two critical phases of genomic imprinting exist. The acquisition phase occurs in developing germ cells, asynchronously for different imprinted loci, while the maintenance phase takes place during preimplantation development, while the rest of the genome is undergoing demethylation. Increased frequencies of human imprinting disorders are observed in children following the use of assisted reproductive technologies (ARTs). The timing of ARTs during the critical periods of imprint acquisition and maintenance provides a mechanism for their disruption. At the onset of this project, I hypothesized that superovulation alone, and embryo culture alone, disrupt imprinting acquisition and maintenance mechanisms, respectively, and that disruption of genomic imprinting correlates with rates of preimplantation embryo development. I have determined the effects of superovulation, and embryo culture using five commercially available media, on the key imprinted loci *H19*, *Snrpn*, *Peg3*, *Kcnq1ot1* and *Peg1/Mest*, and correlated rates of preimplantation development with loss of genomic imprinting. Superovulation alone disrupted genomic imprinting, in a dose-dependent manner. Embryo culture in all media was sub-optimal in maintaining genomic imprints. Embryos developing at a moderate pace showed levels of imprinted methylation most similar to *in vivo*-derived controls. In addition, these studies

suggest that superovulation does not affect the acquisition of imprinted methylation, but rather maintenance throughout preimplantation development. Data presented in this thesis suggests that superovulation disrupts one or more key maternal-effects genes necessary for imprint maintenance, and that superovulation and embryo culture disrupt the same pathway. Future studies delineating the mechanisms mediating embryonic adaptation to the environmental insult caused by ARTs, and improving current techniques to minimize the amount of adaptation required for embryo growth and survival outside the female reproductive tract, will lead to a decreased incidence of disease and improve the long term health of children born following ARTs.

**KEYWORDS:**

Genomic Imprinting, *H19*, *Snrpn*, *Peg3*, *Peg1/Mest*, *Kcnq1ot1*, Assisted Reproductive Technologies, Superovulation, Embryo Culture

## **CO-AUTHORSHIP:**

Chapter 2: Anne Bonvisutto and Dr. Mellissa Mann collected a number of the superovulated embryos used in this study. Lauren Magri and Liyue Zhang were instrumental in the development of the single embryo bisulfite technique. Fatima Ba'abbad provided technical assistance.

Chapter 3: Dr. Andrew Fernandes developed the statistical model used in the analysis of the methylation data. Figures 3.8 was assembled by Dr. Fernandes. Malaika Miles-Rossouw provided technical assistance.

Chapter 4: Real-time PCR of *Atp1a1*, *Slc2a1* and *Mapk14* was performed by Michelle Denomme. Dr. Andrew Fernandes provided guidance for statistical analysis.

Chapter 5: Oocyte data was obtained and analyzed by Michelle Denomme. Collection of superovulated blastocysts was performed by both myself and Michelle Denomme. Preparation of DNA sequences for sequencing analysis from some embryos and imprinted expression of *Peg1/Mest* in superovulated embryos and some *in vivo*-derived embryos was performed by Michelle Denomme.

For my parents, Lori and Clarence, for teaching me to hold on.

For my husband, Vikram, for helping me to not let go.

For my sister, Marisa, for holding on and not letting go.

## **ACKNOWLEDGEMENTS**

First and foremost I would like to thank my supervisor, Dr. Mellissa Mann, for her mentorship, guidance, support and dedication to both me as a student, and to my project. She has been a role model and friend and I am inspired by her passion for the science and her dedication to the research. I have also been fortunate to work with an excellent team in the Mann lab: past members Dr. Michael Golding, Anne Pin, and Sarah Lalone, and current members Liyue Zhang, Michelle Denomme and Lauren Magri. It has been a pleasure working with all of you. I would like to say a special thank you to Dr. Andrew Fernandes for his invaluable help with statistical analysis.

I would also like to thank the MD/PhD program, including our previous program director Dr. Jim Lewis, and our current director Dr. Victor Han. In addition, I need to extend a special thank you to Vicki VanStrien for her administrative support and her dedication to the MD/PhD students from day one, and to Barb Green from the Department of Biochemistry.

I wish to also acknowledge the support and guidance of my graduate committee, including Dr. Victor Han, Dr Nathalie Berube, and my co-supervisor Dr. Andrew Watson. A special thank you to all of them for their encouragement and willingness to take a chance on me and my research. In addition, I would like to extend a thank you to Dr. Stephen Power, who has been an invaluable mentor, always available to talk even with his incredibly busy schedule of clinical and administrative duties. I have really appreciated our discussions, and his support.



I would also like to thank my classmates in the Meds 2013 class for their help during the last months of my graduate work. A special thanks to Rob Moreland for his encouragement and for his tireless work on the podcast project.

On a personal note, I would like to thank my husband, Vikram, for his love and support, through both the ups and downs of basic science research. As well, thanks to my parents and my sister and brother for their visits, discussions, encouragement and inspiration. Lastly, to my mother in particular, for taking the time to “read” all of my manuscripts.

## TABLE OF CONTENTS

<b>CERTIFICATE OF EXAMINATION</b>	ii
<b>ABSTRACT</b>	iii
<b>KEYWORDS</b>	iv
<b>CO-AUTHORSHIP</b>	v
<b>DEDICATION</b>	vi
<b>ACKNOWLEDGMENTS</b>	vii
<b>TABLE OF CONTENTS</b>	ix
<b>LIST OF TABLES</b>	xvi
<b>LIST OF FIGURES</b>	xvii
<b>ETHICS APPROVAL</b>	xx
<b>LIST OF APPENDICES</b>	xxi
<b>LIST OF ABBREVIATIONS</b>	xxii
<b>Chapter 1: Introduction</b>	1
1.1 Epigenetics	1
1.1.1 Early Epigenetics	1
1.1.2 Modern Epigenetics	2
1.1.3 Mechanisms of Epigenetic Regulation	2
1.1.3.1 Histone Modifications	3
1.1.3.2 DNA Methylation	7
1.1.3.3 Long Non-Coding RNA	11
1.1.3.3 Nuclear Territories and Chromatin Looping	12
1.2 Genomic Imprinting	13
1.2.1 Brief History of Genomic Imprinting	13
1.2.2 Overview of Genomic Imprinting	14
1.2.3 Imprinted Domains of Interest, their Regulation and Associated Syndromes	20
1.2.3.1 <i>H19</i> Imprinted Domain	20

1.2.3.1.1 Structure and Regulation of the Domain	20
1.2.3.1.2 Beckwith-Wiedemann Syndrome and the <i>H19</i> Domain	21
1.2.3.2 <i>Kcnq1ot1</i> Imprinted Domain	22
1.2.3.2.1 Structure and Regulation of the Domain	22
1.2.3.2.2 Beckwith Wiedemann Syndrome and the <i>Kcnq1ot1</i> Domain	23
1.2.3.3 <i>Peg1/Mest</i> Imprinted Domain	24
1.2.3.3.1 Structure and Regulation of the Domain	24
1.2.3.3.2 Silver-Russell Syndrome and the <i>Peg1/Mest</i> Domain	25
1.2.3.4 <i>Snrpn</i> Imprinted Domain	25
1.2.3.4.1 Structure and Regulation of the Domain	25
1.2.3.3.2 PWS, AS and the <i>Snrpn</i> Domain	27
1.2.3.5 <i>Peg3</i> Imprinted Domain	27
1.2.4 Acquisition of Genomic Imprinting in Germ Cells	29
1.2.4.1 Acquisition in Oocytes	29
1.2.4.2 Acquisition in Spermatocytes	30
1.2.5 Maintenance of Genomic Imprinting	30
1.3 - Assisted Reproductive Technologies	32
1.3.1 Prevalence of ARTs and Their Sequelae	32
1.3.2 Superovulation and Effects on Genomic Imprinting	34
1.3.3 Embryo Culture and Effects on Genomic Imprinting	36
1.5 - Rationale	39
1.6 - Hypothesis	40
1.7 - Objectives	40
1.8 References	41
 <b>Chapter 2: The Effects of Superovulation on Genomic Imprinting</b>	 57

2.1 Introduction	57
2.2 Methods	60
2.2.1 Ovarian Stimulation and Embryo Collection	60
2.2.2 DNA Isolation and Bisulfite Mutagenesis for Individual Embryos	61
2.2.3 Allele-Specific DNA Methylation Analysis of Individual Embryos for <i>Snrpn</i> , <i>Peg3</i> , <i>Kcnq1ot1</i> , and <i>H19</i>	62
2.2.4 Sequence Analysis	64
2.2.5 Statistical Analysis	65
2.3 Results	66
2.3.1 Methylation levels of <i>Snrpn</i> , <i>Peg3</i> , <i>Kcnq1ot1</i> , and <i>H19</i> in spontaneously ovulated embryos	66
2.3.2 Superovulation results in loss of maternal <i>Snrpn</i> , <i>Peg3</i> , and <i>Kcnq1ot1</i> methylation in a dose-dependent manner	69
2.3.3 Superovulation results in gain of maternal <i>H19</i> methylation in a dose-dependent manner	76
2.3.4 Superovulation results in loss of paternal <i>H19</i> methylation in a dose-dependent manner	79
2.3.5 Perturbation of Imprinted Methylation for Multiple Genes	85
2.4 Discussion	87
2.4.1 Superovulation Perturbs Genomic Imprinting	87
2.4.2 Superovulation Perturbs Genomic Imprinting for Multiple Genes in the Same Embryo	90
2.4.3 Superovulation may lead to perturbation in imprint acquisition as well as imprint maintenance	91
2.4.4 Dose-Dependent Effects of Superovulation	92
2.5 References	95

<b>Chapter 3: The Effects of Embryo Culture on Genomic Imprinting: Comparing 5 Commercially Available Media</b>	99
3.1 Introduction	99
3.2 Materials and Methods	102
3.2.1 Embryo Collection	103
3.2.2 Embryo Culture	103
3.2.3 Imprinted Methylation Analysis	105
3.2.4 Imprinted Expression Analysis	107
3.2.5 Statistical Methods	108
3.3 Results	111
3.3.1 Effects of Embryo Culture on Imprinted Methylation	111
3.3.2 Effects of Embryo Culture on Imprinted Gene Expression	126
3.3.3 Effects of Superovulation and Embryo Culture on Imprinted Expression	131
3.4 Discussion	133
3.4.1 Comparison of Media Systems	133
3.4.2 Combined effects of ART treatments	137
3.5 References	140
<b>Chapter 4: Rates of Embryo Development Correlate with Loss of Genomic Imprinting</b>	145
4.1 Introduction	145
4.2 Materials and Methods	149
4.2.1 Embryo Collection	149
4.2.2 Embryo Culture	150
4.2.3 Imaging and Cell Counting	150
4.2.4 Analysis of Imprinted Methylation and Expression	151
4.2.5 Sex Determination in Individual Embryos	153
4.2.6 <i>Cdkn1c</i> Imprinted Expression Analysis	153

4.2.7 Expression Analysis of <i>Atp1a1</i> , <i>Slc2a1</i> and <i>Mapk14</i>	155
4.2.8 Statistical Analysis	155
4.3 Results	156
4.3.1 Effects of Embryo Culture on Blastocyst Cell Number and Volume	156
4.3.2 Effects of Embryo Culture on Embryo Sex Ratios	163
4.3.3 Effects of Embryo Culture on <i>H19</i> and <i>Snrpn</i> Imprinting	164
4.3.4 Effects of Embryo Culture on <i>Cdkn1c</i> Imprinted Expression	173
4.3.5 Effects of Embryo Culture on Metabolic Marker Expression	174
4.4 Discussion	178
4.4.1 Relationship between Development Rates and Genomic Imprinting	179
4.4.2 Relationship Between Development Rates and Embryo Volume	180
4.4.3 Relationship between Development Rates and Embryo Metabolism	182
4.4.4 The Best Embryos for Transfer	185
4.5 References	190
<b>Chapter 5 - The Effects of Superovulation and Embryo Culture at the <i>Peg1/Mest</i> Locus</b>	198
5.1 Introduction	198
5.2 Methods	201
5.2.1 B6(CAST7p6) Mouse Model	201
5.2.2 Oocyte and Embryo Collection and Culture	204
5.2.3 Analysis of <i>Peg1/Mest</i> Imprinted Methylation and Expression	206
5.2.4 Statistical Analysis	208
5.3 Results	208
5.3.1 Effects of Superovulation on <i>Peg1/Mest</i> Imprinted	

Methylation in Oocytes	208
5.3.2 <i>In Vivo</i> Patterns of Imprinted Methylation at the <i>Peg1/Mest</i> DMR in Blastocysts	211
5.3.3 Effects of Superovulation on Imprinted Methylation at the <i>Peg1/Mest</i> DMR in Blastocysts	213
5.3.4 Effects of Embryo Culture on Imprinted Methylation at the <i>Peg1/Mest</i> DMR in Blastocysts	213
5.3.5 Effects of Superovulation and Embryo Culture on <i>Peg1/Mest</i> Imprinted Expression	216
5.4 Discussion	221
5.4.1 Maintenance, Not Acquisition, is Affected by Superovulation	224
5.4.2 <i>In Vitro</i> Culture, but not Rates of Early Development Affect Methylation of <i>Peg1/Mest</i>	226
5.4.4 Imprinted Expression of <i>Peg1/Mest</i> is Unaffected by Superovulation, and Embryo Culture	228
5.5 References	230
<b>Chapter 6 - Discussion</b>	234
6.1 ARTs Affect Genomic Imprinting	235
6.1.1 Superovulation	235
6.1.2 Embryo Culture	238
6.1.3 Multiple ARTs	242
6.2 Stochastic Effects of ARTs	242
6.3 The Mouse Model and Application to the Human Clinic	244
6.4 Future Directions	246
6.4.1 Superovulation	246
6.4.2 Embryo Culture	250
6.4.3 Application to the Human Clinic	252
6.5 Conclusions	254

6.6 References	256
<b>Appendices</b>	262
Appendix 1: Single Embryo Methodology	262
Appendix 2: Perl Program for Sequencing Analysis	276
Appendix 3: Supplementary Material - Chapter 2	277
Appendix 4: Supplementary Material - Chapter 3	305
Appendix 5: Copyright Releases	312
<b>Curriculum Vitae</b>	314



## **LIST OF TABLES**

Table 1.1: Imprinted Genes, their Imprinted Domains and Associated Human Disorders	19
Table 2.1. Regions and Conditions for PCR Analysis Following Bisulfite Mutagenesis.	63
Table 2.2. Comparison of Hormone Dosage and Aberrant Imprinted Methylation	86
Table 3.1: Timeline for Spontaneous / Induced Ovulation and Culture	104
Table 3.2: Expression Analysis of Cultured and Superovulation and Cultured Embryos	127
Table 4.1: Primers and PCR Protocols	154

## **LIST OF FIGURES**

Figure 1.1: Mechanisms of Epigenetic Regulation	4
Figure 1.2: The Nucleosome and Histone Modifications	6
Figure 1.3: DNA Methylation by DNMTs	9
Figure 1.4: DNA Methylation Throughout Germ Cell and Preimplantation Embryo Development.	10
Figure 1.5: Genomic Imprinting	15
Figure 1.6: Models of Epigenetic Regulation	17
Figure 2.1. Schematic Diagram of Regions Analyzed by Bisulfite Mutagenesis and Sequencing Assay.	67
Figure 2.2. Methylation of the Maternal <i>Snrpn</i> ICR in B6(CAST7) X B6 F1 Embryos Derived from Low Dosage Superovulated Females.	71
Figure 2.3: Methylation of the Maternal <i>Snrpn</i> ICR in B6(CAST7) X B6 F1 Embryos Derived from High Dosage Superovulated Females.	73
Figure 2.4. Methylation of the Maternal <i>Peg3</i> DMR in B6(CAST7) X B6 F1 Embryos Derived from Low Dosage Superovulated Females.	74
Figure 2.5. Methylation of the Maternal <i>Peg3</i> DMR in B6(CAST7) X B6 F1 Embryos Derived from High Dosage Superovulated Females.	75
Figure 2.6. Methylation of the Maternal <i>Kcnq1ot1</i> ICR in B6(CAST7) X B6 F1 Embryos Derived from Low Dosage Superovulated Females.	77
Figure 2.7. Methylation of the Maternal <i>Kcnq1ot1</i> ICR in B6(CAST7) X B6 F1 Embryos Derived from High Dosage Superovulated Females.	78
Figure 2.8. Methylation of the Maternal <i>H19</i> ICR in B6(CAST7) X B6 F1 Embryos Derived from Low Dosage Superovulated Females.	80
Figure 2.9. Methylation of the Maternal <i>H19</i> ICR in B6(CAST7) X B6 F1 Embryos Derived from High Dosage Superovulated Females.	81
Figure 2.10. Methylation of the Paternal <i>H19</i> ICR in B6(CAST7) X B6 F1 Embryos Derived from Low Dosage Superovulated Females.	82
Figure 2.11. Methylation of the Paternal <i>H19</i> ICR in B6(CAST7) X B6 F1	

Embryos Derived from High Dosage Superovulated Females.	83
Figure 3.1. Schematic Diagram of Regions Analyzed for Imprinted Methylation.	113
Figure 3.2. Methylation in Whitten's Medium.	115
Figure 3.3. Methylation in KSOMaa.	116
Figure 3.4. Methylation in Global Medium.	117
Figure 3.5. Methylation in HTF Medium.	118
Figure 3.6. Methylation in P1/MB Medium.	119
Figure 3.7. Methylation in G1.5/G2.5 Medium.	120
Figure 3.8. Methylation Analysis	122
Figure 3.9. Imprinted Expression of <i>H19</i> - Spontaneous Ovulation and Culture	129
Figure 3.10. Imprinted Expression of <i>H19</i> - Superovulation and Cultured Embryos	132
Figure 4.1: Embryo Separation and Analysis	158
Figure 4.2: Cell Numbers, Embryo Volume and Embryo Sex	160
Figure 4.3: Imprinted Methylation of <i>H19</i> in FF and FS Groups	165
Figure 4.4: Imprinted Methylation of <i>H19</i> in SF and SS Groups	165
Figure 4.5: Graphical Representation of Levels of <i>H19</i> and <i>Snrpn</i> Hypermethylation	168
Figure 4.6: Imprinted Methylation of <i>Snrpn</i> in FF and FS Groups	169
Figure 4.7: Imprinted Methylation of <i>Snrpn</i> in SF and SS Groups	170
Figure 4.8: <i>H19</i> , <i>Snrpn</i> and <i>Cdkn1c</i> Imprinted Expression	172
Figure 4.9: Expression of Genes Involved in Embryo Metabolism	175
Figure 4.10 Summary of Multiple Parameter Analysis at the Individual Embryo Level	187
Figure 5.1: Crossover Sites in the B6(CAST7p6) Mouse Model	203
Figure 5.2. Methylation of <i>Peg1/Mest</i> in Oocytes	210
Figure 5.3: Methylation of the <i>Peg1/Mest</i> DMR in Embryos derived from Spontaneously Ovulating Females.	212
Figure 5.4: Methylation of the <i>Peg1/Mest</i> DMR in Embryos derived from	

Superovulated (6.25 IU) Females	214
Figure 5.5: Methylation of the <i>Peg1/Mest</i> DMR in Embryos derived from Superovulated (10 IU) Females	215
Figure 5.6: Methylation of the <i>Peg1/Mest</i> DMR in Blastocysts From the FF Group	217
Figure 5.7: Methylation of the <i>Peg1/Mest</i> DMR in Blastocysts From the FS Group	218
Figure 5.8: Methylation of the <i>Peg1/Mest</i> DMR in Blastocysts From the SF Group	219
Figure 5.9: Methylation of the <i>Peg1/Mest</i> DMR in Blastocysts From the SS Group	220
Figure 5.10: Imprinted Expression of <i>Peg1/Mest</i> in Spontaneous and Superovulated Blastocysts	222
Figure 5.11: Imprinted Expression of <i>Peg1/Mest</i> in Cultured Embryos	223

## **ETHICS APPROVAL**

All studies were performed in compliance with the guidelines set by the Canadian Council for Animal Care, and the policies and procedures approved by the University of Western Ontario Council on Animal Care.

## **LIST OF APPENDICES**

1. Method: Single embryo analysis of methylation and expression
2. Perl program for the analysis of sequencing data
3. Supplemental data from 2010 Human Molecular Genetics publication
4. Supplemental data from 2010 Biology of Reproduction publication
5. Copyright releases

## **LIST OF ABBREVIATIONS**

%	Percent
°C	Degrees Celcius
$\Delta\Delta Ct$	Delta delta cycle threshold
-ve	Negative
A	Adenine
Ac	Acetyl group
ART	Assisted reproductive technologies
aov	ANOVA (used in R programming)
ANOVA	Analysis of variance
AS	Angelman Syndrome
AS-IC	Angelamn Syndrome imprinting center
<i>Atp1a1</i>	ATPase, Na <sup>+</sup> /K <sup>+</sup> transporting, alpha 1 polypeptide
<i>b-actin</i>	Beta actin
B6	C57BL/6
bp	Base pair
BWS	Beckwith-Wiedemann Syndrome
CAST	Mus musculus castaneus
<i>Cdkn1c</i>	Cyclin-dependent kinase inhibitor 1C
cDNA	Complementary deoxyribonucleic acid
<i>Copg2</i>	Coatomer protein complex, subunit gamma 2
C	Cytosine
<i>Cbx1</i>	Chromobox protein homolog 1
CO <sub>2</sub>	Carbon dioxide
CpG	Phosphorylated cytosine followed by guanine
CT	Chromosome territory
CTCF	CCCTC-binding factor
DMR	Differentially methylated domain
DMSO	Dimethyl sulfoxide
DNA	Deoxyribonucleic acid
DNase	Deoxyribonuclease
DNMT	DNA methyltransferase
DNMT1	DNA methyltransferase 1
DNMT3A	DNA methylatransferase 3a
DNMT3B	DNA methylatransferase 3b
dpc	Days postcoitum
DTT	Dithiothreitol
E	Enhancer
<i>E-cadherin</i>	Epithelial cadherin
EDTA	Ethylenediaminetetraaceticacid
F <sub>1</sub>	First filial generation
FF	Fast/Fast embryo group

FS	Fast/Slow embryo group
G	Guanine
<i>Glut1</i>	Glucose transporter 1
H	Histone
H1	Histone 1
H2A	Histone 2 A
H2B	Histone 2 B
H3	Histone 3
H4	Histone 4
<i>H19</i>	hepatocyte #19 fetal liver mRNA
HCl	Hydrogen chloride
hCG	Human chorionic gonadotropin
HP1	Heterochromatin protein 1
HTF	Human tubal fluid
IC	Imprinting center
ICR	Imprinting control region
ICSI	Intracytoplasmic sperm injection
<i>Igf2</i>	Insulin-like growth factor 2
Ins	Insulator
IPTG	Isopropyl beta-D-1-thiogalactopyranoside
ITT	IGEPAL, Tween 20, TE
IU	International Units
IUGR	Intrauterine growth restriction
IVF	In vitro fertilization
K	Lysine
<i>Kcnq1</i>	Potassium voltage-gated channel, KQT-like subfamily member 1
<i>Kcnq1ot1</i>	<i>Kcnq1</i> overlapping transcript 1
KLD	Kullback-Leibler Divergence
<i>Klf14</i>	Kruppel-like factor 14
KSOMaa	Potassium simplex optimized medium with amino acids
<i>Lefty2</i>	Left-right determining factor 2
LiCl	Lithium chloride
LiDS	Lithium dodecyl-sulfate
lm	Linear model
LMP	Low melting point
LOI	Loss of imprinting
<i>Magel2</i>	Melanoma antigen, family L, 2
<i>Mapk14</i>	Mitogen-activated protein kinase 4
MB	Multiblast Medium
MB	Megabase
me	Methyl group



<i>Mecp2</i>	Methyl CpG binding protein 2
<i>Mkrn3</i>	<i>Makorin</i> , ring finger protein, 3
min	Minute
<i>Morf411</i>	Mortality factor 4 like 1
mL	Milliliter
MPC	Magnetic particle concentrator
<i>Mrpl1</i>	Mitochondrial ribosomal protein-like 1
µg	Microgram
µL	Microliter
µM	Micromolar
N	Nitrogen
NaCl	Sodium chloride
Na/K ATPase	Sodium / potassium adenosine triphosphatase
NaOH	Sodium hydroxide
<i>Ndn</i>	Necdin
ng	Nanogram
O	Oxygen
<i>Oct4</i>	Octamer-binding transcription factor 4
P	Phosphate group
P1	Preimplantation stage 1 medium
PCR	Polymerase chain reaction
<i>Peg1/Mest</i>	Paternally expressed gene 1 / mesoderm specific transcript
<i>Peg3</i>	Paternally expressed gene 3
<i>Pelo</i>	Pelota homolog
pg	Picogram
PMSG	Pregnant mare's serum gonadotropin
PWS-IC	Prader-Willi Syndrome imprinting center
r	Radius
RNA	Ribonucleic acid
RNase	Ribonuclease
S	Serine
sec	Second
SF	Slow/Fast embryo group
<i>Sfrs3</i>	Serine/arginine-rich splicing factor 3
<i>Slc2a1</i>	Solute carrier family 2, member 1
snoRNA	Small nucleolar RNA
SNP	Single nucleotide polymorphism
<i>Snrpn</i>	Small nuclear ribonucleoprotein
<i>Snrpn-lt</i>	<i>Snrpn</i> long transcript
<i>Spp1</i>	Secreted phosphoprotein 1
SRS	Silver Russell Syndrome
<i>Sry</i>	Sex-determining region Y

SS	Slow/Slow embryo group
T	Thymine
<i>Tif1beta/Trim 28</i>	Translation initiation factor 1 beta / tripartite motif-containing 28
TE	Tris-EDTA
<i>Tex20</i>	Testis expressed gene 20
TF	Transcription factor
tRNA	Transfer RNA
<i>Ube3a</i>	Ubiquitin protein ligase E3A
<i>Ube3a</i>	<i>Ube3a</i> -antisense
<i>Usp29</i>	Ubiquitin specific peptidase 29
V	Volume
X-gal	5-bromo-4-chloro-3-indolyl-beta-D-galactopyranoside
<i>Xist</i>	Inactive X specific transcripts
YY1	Ying and yang protein 1
<i>Zfp264</i>	Zinc finger protein 264
<i>Zim1</i>	Zinc finger, imprinted 1
<i>Zim2</i>	Zinc finger, imprinted 2
<i>Zim3</i>	Zinc finger, imprinted 3

## **Chapter 1: Introduction**

### **1.1 - Epigenetics**

#### **1.1.1 Early Epigenetics**

While the concept of genes and their role in development is well known, the concept of epigenetics is a relatively recent idea, and as such, much remains to be discovered in the field. The term “epigenetics” was originally coined by C. H. Waddington in the 1940s, resulting from a combination of the words “epigenesis”, referring to the theory of animal development whereby development occurs in a step-wise manner resulting from successive differentiation rather than enlargement of preformed structures, and “genetics”, the theories and information originally derived from Mendelian ideology (Van Speybroeck, 2002). Waddington’s ideas brought the concepts of genetics into the study of embryology, suggesting that genes interact in a number of ways, which are not static in every individual, to create unique organisms (Waddington, 1939). The frequency of discordance between genotype, the genetic makeup of the individual, and phenotype, the observed physical characteristics, began to demand an addendum to Mendel’s laws of inheritance, which could account for these disagreements. Waddington suggested that the genotype of an individual did not dictate the phenotype, but simply provided a range of possible phenotypes, governed by some other processes (Waddington, 1939). In addition, Waddington postulated that these other processes not only played a role in inter-individual variation, but were also responsible for regulating the development of different tissues within the same individual (Waddington, 1939).

Essentially, the phenotype was a result of interactions between genetic processes and their cytoplasmic and external environments (Waddington, 1939).

### **1.1.2 Modern Epigenetics**

Today, this concept has evolved, and we understand the term epigenetics as a combination of the word “genetics” and the prefix “epi”, meaning “on top of”. In essence, epigenetics encompasses the study of heritable and reversible modifications of chromatin that influence the accessibility of genes and regulate gene transcription (Rodenhiser and Mann, 2006). The plastic nature of epigenetics recapitulates Waddington’s ideas of cytoplasmic and external environments modulating the genetics of an organism. Over the course of the last 50 years, as our understanding of the nuclear microenvironment and the composition and organization of the genome rapidly expanded, many advancements have been made that elucidated the core epigenetic mechanisms modulating these nuclear components resulting in modulation of gene expression.

### **1.1.3 Mechanisms of Epigenetic Regulation**

Epigenetic mechanisms can modulate every aspect of the genetic material, from the ionic microenvironment of chromatin to the sub-nuclear localization of entire chromosomes. Known mechanisms include histone modifications, DNA methylation and long non-coding RNAs, which, along with chromatin looping and the formation of

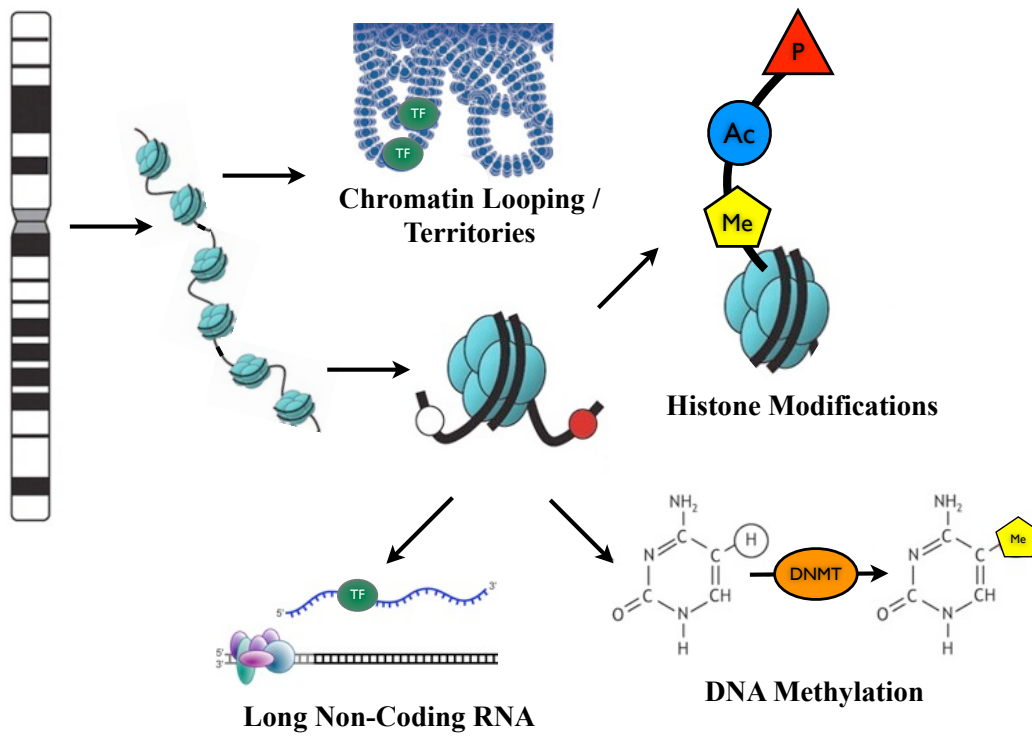
chromatin territories (CT), result in changes to chromatin structure and localization within the nucleus (Figure 1.1).

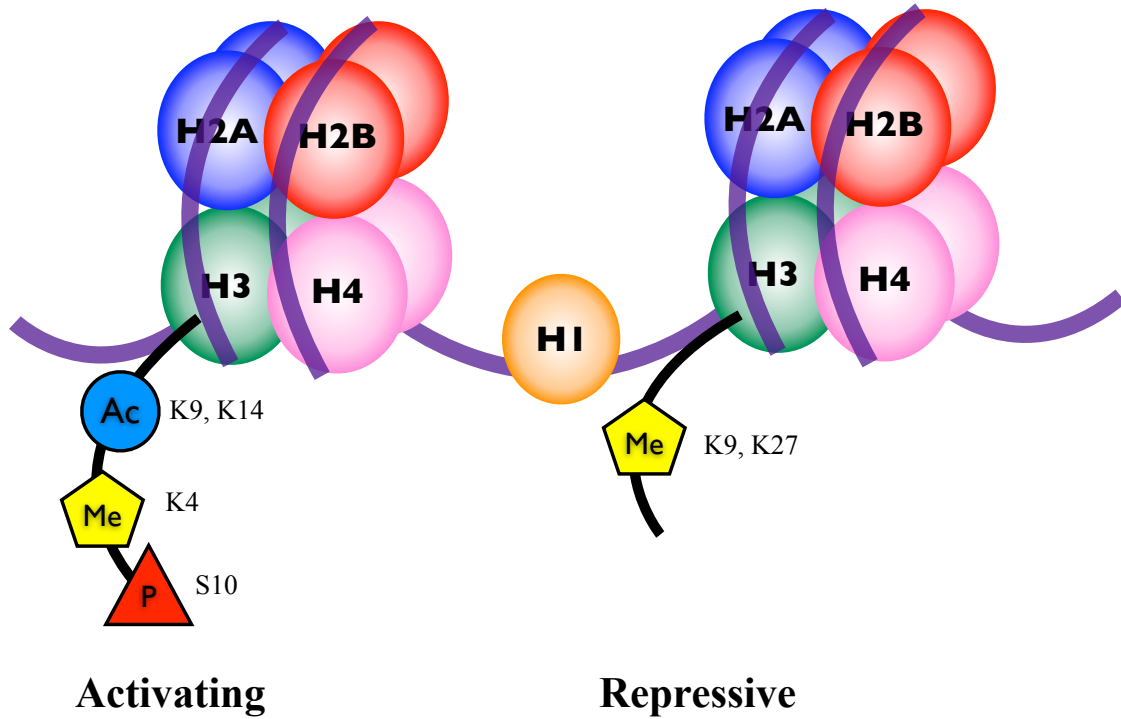
### **1.1.3.1 Histone Modifications**

The basic unit of DNA is the nucleosome which consists of double-stranded DNA wrapped around octamers of histone proteins (Kornberg, 1974), two each of H2A, H2B, H3, and H4, with H1 linker histones establishing spacing between nucleosomes (Figure 1.1, 1.2). These histone proteins contain specific amino acid residues that can undergo post-translational modifications that modulate their charge and hydrophobicity (Lehninger et al., 2005). Modulation of these two factors can change the local, or the global structure of chromatin organization resulting in local areas of open or closed chromatin, or silencing of entire chromosomes. A number of histone modifications have been extensively studied and are consistently associated with either open (active), or closed (repressed) chromatin conformations. Acetylation of lysine tails, such as H3K9, and H3K14, (Turner and Fellows, 1989; Schiltz et al., 1999; Vaquero et al., 2004), and phosphorylation of serine and threonine residues such as H3S10 (Sassone-Corsi et al., 1999; Anest et al., 2003), result in a more active chromatin state. Other modifications such as methylation, sumoylation, and ubiquitination have more diverse functions in chromatin organization, and depending on their location, can act as either repressive or activating marks. Histone methylation can occur on either lysine or arginine residues, and can be mono-, di-, or tri-methylated. For example, tri-methylation of H3K4 results in an active chromatin conformation, while tri-methylation of H3K9 and H3K27 are repressive

### **Figure 1.1: Mechanisms of Epigenetic Regulation**

Epigenetic modifications include chromatin looping, histone modifications and DNA methylation. Chromatin looping allows binding of transcription factors (TF) to active regions of chromatin, while inactive regions are more likely located in the core of the chromosome territories. DNA is made up of a series of nucleosomes, which contains histones and DNA. Histone can be post-translationally modified in a number of ways, a few of which are methylation (Me), acetylation (Ac) and phosphorylation (P). These marks can be activating or repressive depending on their nature and location. DNA can be methylated on the 5' carbon of cytosine residues by DNA methyl transferase enzymes (DNMTs), which is most often a repressive mark. Long non-coding RNAs mediate epigenetic modifications in *cis* and *trans* through interactions with chromatin complexes and transcription factors. Figure adapted from: Rodenhiser and Mann, 2006, Epigenetics and human disease: translating basic biology into clinical applications. *CMAJ*; 174(3): 341-348, Luong, P. 2009. Basic Principles of Genetics., <http://web.me.com/marschalf/classes-taught/apbiology/Spry-resources.htm>, and Fraser, P., and Bickmore, W., 2007, Nuclear organization of the genome and the potential for gene regulation, *Nature* 447, 413-417





**Figure 1.2: The Nucleosome and Histone Modifications**

The nucleosome consists of an octamer of dimers of H2A, H2B, H3, and H4, with the H1 linker protein establishing the space between nucleosomes. DNA is wrapped around each nucleosome twice, resulting in approximately 147 bp of DNA per nucleosome. This figure indicates the most common modifications of the H3 protein resulting in activation or repression of gene expression. Ac: acetylation, Me: methylation, P: phosphorylation



(Lehninger et al., 2005). Importantly, all of the above histone modifications are reversible, and therefore allow for temporal as well as spatial control of chromatin structure. It is evident that control of chromatin state by histone modifications is a complex process, involves a large network of proteins and has the capacity to finely modulate gene expression throughout the life cycle.

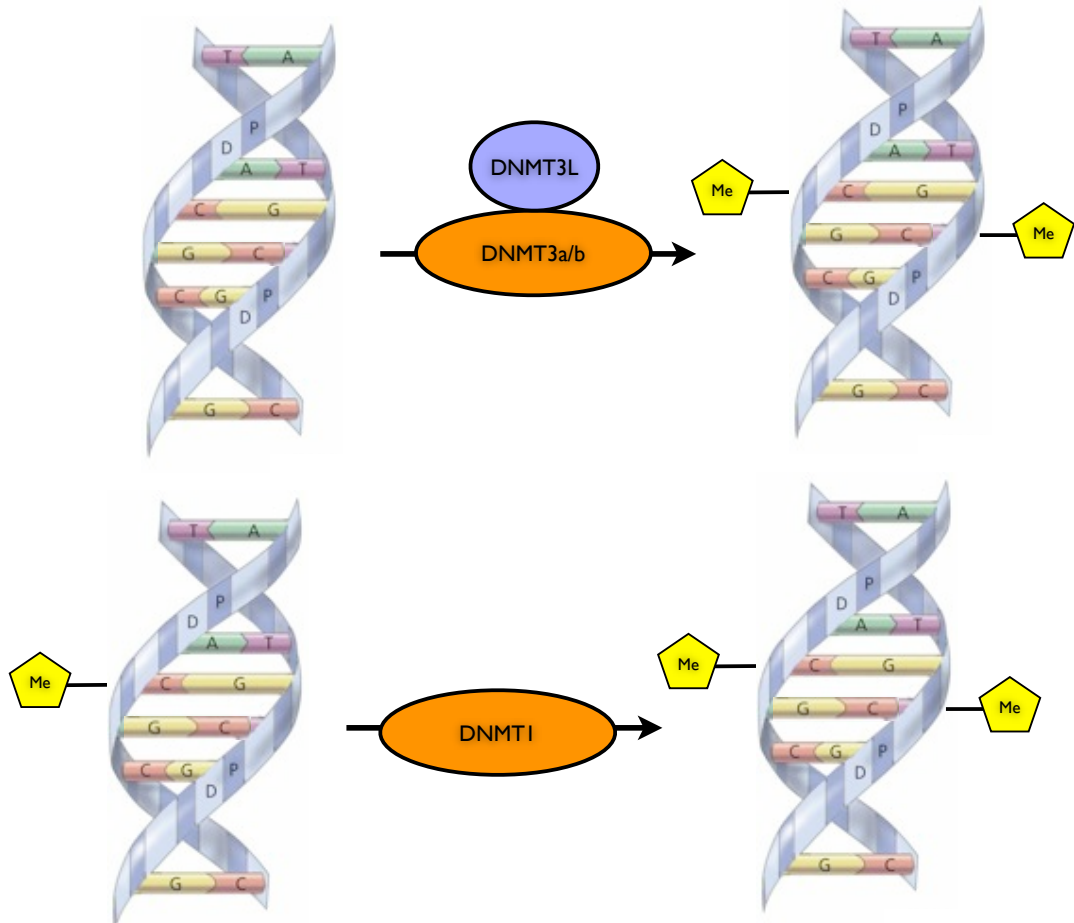
In early embryos, the paternal genome also acquires repressive histone modifications, including histone 3 lysine 9 and lysine 27 methylation (H3K9me2, H3K27me2, and H3K27me3). By comparison, the maternal genome possesses both active (H4Ac, H3K4me1) and repressive histone modifications (H3K9me2, H3K9me3, and H4K20me3) (Adenot et al., 1997; Cowell et al., 2002; Lepikhov and Walter, 2004). These covalent modifications are proposed to initiate the transcriptionally repressed state that coincides with embryonic genomic activation. This potential for chromatin bivalency, where both activating and repressive marks occupy the same stretch of chromatin, is likely a major factor in establishing the correct gene expression profile for embryonic development (Schultz, 2002).

### **1.1.3.2 DNA Methylation**

DNA methylation is another important epigenetic mechanism regulating gene expression and consists of the covalent addition of a methyl group to the C5 position of cytosine residues within CpG dinucleotides (Figure 1.1). DNA methylation is most often associated with repression of gene expression (Lehninger et al., 2005). A family of

enzymes known as the DNA methyltransferases (DNMTs) is responsible for the addition of these methyl groups (Figure 1.3), while the mechanism of de-methylation is less clear. *De novo* DNA methyltransferases that add methyl groups to unmethylated CpGs are DNMT3A and DNMT3B (Okano et al., 1998; Okano et al., 1999). As such, these enzymes are responsible for the establishment of DNA methylation during early development and differentiation, in conjunction with other enzymes such as DNMT3L, and other regulatory complexes (Lehninger et al., 2005). DNA methylation is heritable throughout successive rounds of DNA replication due to the action of DNMT1, the maintenance methyltransferase, which recognizes hemi-methylated DNA and adds a methyl group to the daughter strand (Figure 1.3). With regards to DNA demethylation, our current understanding suggests that passive demethylation occurs through the absence of maintenance methylation (DNMT1) (Morgan et al., 2005), while active demethylation either utilized a multistep DNA repair mechanism, or converts methylated cytosines to different compounds to facilitate direct removal. These modifications include DNA glycosylation or 5'-hydroxy methylation through the Tet family of enzymes (Morgan et al., 2005; Schar and Fritsch, 2011).

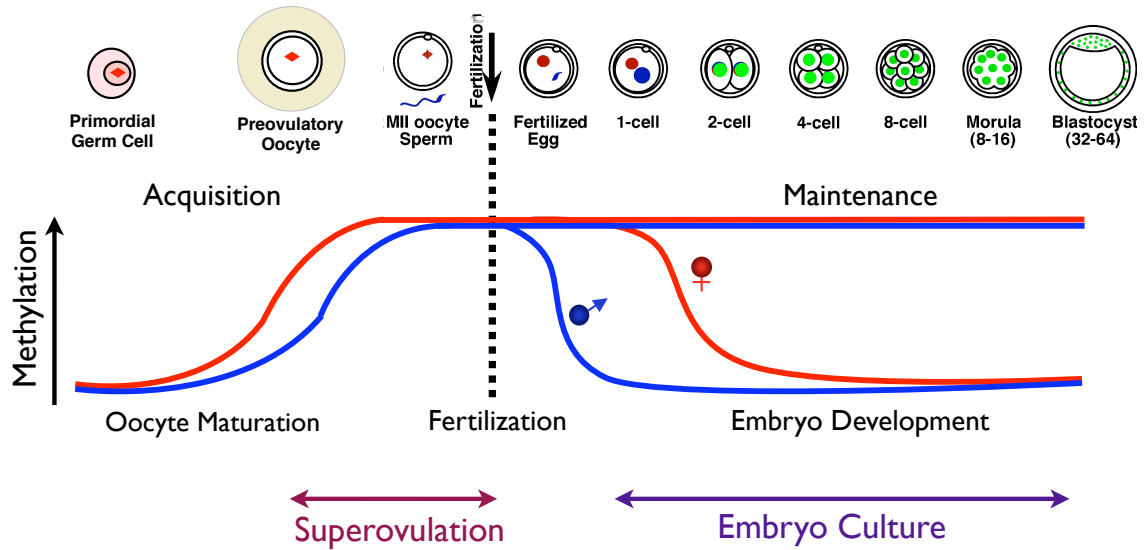
Acquisition of DNA methylation occurs in the developing gametes and is acquired differentially between the two parental genomes (Hajkova et al., 2002; Kageyama et al., 2007) (Figure 1.4). Following fertilization, there is a wave of demethylation that erases gamete-specific methylation patterns and ensures the totipotency of the early embryo (Mayer et al., 2000; Dean et al., 2001; Santos et al., 2002; Beaujean et al., 2004). The



**Figure 1.3: DNA Methylation by DNMTs**

DNA methylation is performed by DNA methyltransferases. CpG dinucleotides are methylated *de novo* by DNMT3A/B in conjunction with DNMT3L. Hemi-methylated DNA is fully methylated by DNMT1 following DNA replication. Me: methyl group.

Adapted from <http://images.yourdictionary.com/DNA>.



**Figure 1.4: DNA Methylation Throughout Germ Cell and Preimplantation Embryo Development.**

Acquisition of DNA methylation begins in the developing oocyte and spermatocytes, and is complete prior to fertilization. At fertilization, the paternal pronucleus undergoes active demethylation, while the maternal pronucleus undergoes passive demethylation throughout the early stages of preimplantation development. Imprinted methylation is maintained throughout preimplantation development, despite the demethylation occurring in the rest of the genome. Superovulation occurs during the time of imprint acquisition, and embryo culture takes place during maintenance of genomic imprinting. Figure adapted from Mann, M.R.W. and Bartolomei, M.S., *Genome Biology*. 3(2) 1003.1-1003.4 2002.

paternal genome is actively demethylated within hours after fertilization, while the maternal genome is passively demethylated during early cleavage divisions in a replication-dependent manner through a lack of maintenance methylation (Rougier et al., 1998; Oswald et al., 2000). The end result is that the two parental genomes undergo extensive changes in global methylation during preimplantation development. Post-implantation, *de novo* methylation gradually increases in accordance with cellular differentiation (Monk et al., 1987).

### **1.1.3.3 Long Non-Coding RNA**

Studies of the human genome have revealed that only 1-2% of the DNA sequences carry protein-coding information, leading scientists to question the function of the other 98% (Lee, 2010). Recently, a class of RNAs have been discovered that are not transcribed into protein products, but instead play an important role in epigenetic regulation (Guttman et al., 2009; Khalil et al., 2009). Transcription of these long non-coding RNAs occurs throughout the genome, overlapping with, and between other protein-coding genes (Carninci et al., 2005; Kapranov et al., 2007). Many long non-coding RNAs have been identified which show significant evolutionary conservation (Guttman et al., 2009) and differences in expression across tissue types indicating a functional role in genomic regulation (Dinger et al., 2008; Guttman et al., 2009). Long-non coding RNAs can affect the expression of other protein-coding genes using both *cis*- and *trans*-acting mechanisms. They can associate with chromatin modifying complexes, resulting in the addition of activating or repressive histone marks to these areas (Bracken

et al., 2006; Dinger et al., 2008; Ku et al., 2008; Nagano et al., 2008; Pandey et al., 2008), or RNA-binding proteins and transcription factors, resulting in recruitment to specific areas of the genome in *cis* or *trans* (Feng et al., 2006; Rinn et al., 2007; Wang et al., 2008; Zhao et al., 2008; Khalil et al., 2009). Additional evidence suggests that elongation of the transcript, or the act of transcription through the domain itself is important for domain regulation. While the exact mechanism is unknown, silencing may occur through the interaction of RNA polymerase and the tethered non-coding RNA, leading to recruitment of repressive chromatin complexes to areas of elongation in *cis* (Mancini-Dinardo et al., 2006), or through the interaction of the transcript with mRNAs in the domain generating double-stranded RNA, thereby activating RNA interference mechanisms (Dykxhoorn et al., 2003).

#### **1.1.3.4 Nuclear Territories and Chromatin Looping**

Both histone modifications and DNA methylation can result in local alterations of chromatin structure, but also alter gene expression on a larger scale. Within the nucleus, chromosomes are organized into a number of chromosome territories (CTs) and it was initially postulated that active regions (euchromatin) lie in chromatin loops at the surface and inactive regions are located deep within the territories (heterochromatin) (Zirbel et al., 1993) (Figure 1.1). This sequestration of inactive regions to the core of the territory presumably prevents access to the transcriptional machinery, and these heterochromatic regions replicated later in S phase than their euchromatin counterparts (Gilbert, 2002). We now know that gene-poor regions tend to localize to the core of CTs, while gene-rich

regions tend to cluster at the surface (Shopland et al., 2006). Studies also suggest that “looping out” of specific chromatin regions is associated with activation of transcription, and that these active regions, on the same or on different chromosomes, interact with one another (Chambeyron and Bickmore, 2004; Wurtele and Chartrand, 2006). In addition, regions of constitutively high activity are often found “looped out”, in regions outside their normal CT (Mahy et al., 2002; Brown et al., 2006). However, not all “looped out” regions of chromatin are active, but instead represent regions poised for transcription, with additional chromatin modifications necessary for active transcription to occur (Heard and Bickmore, 2007).

## **1.2 - Genomic Imprinting**

### **1.2.1 Brief History of Genomic Imprinting**

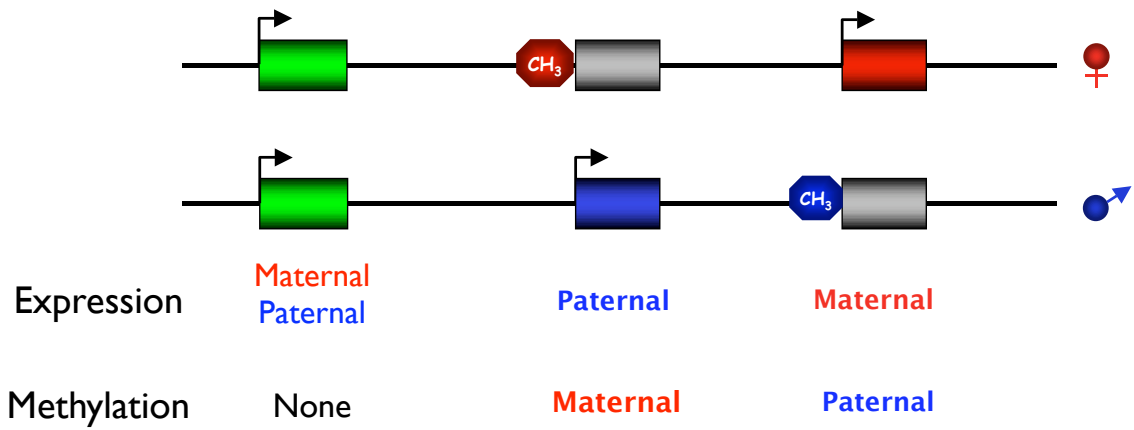
Genomic imprinting is an epigenetic phenomenon whose investigation is still in its infancy. The term “imprint” was originally coined by H. V. Crouse from experiments on the insect *Sciara*. During sperm, but not oocyte development, *Sciara* selectively eliminate the paternal X chromosome (Crouse, 1960). After fertilization, one or both remaining X chromosomes are eliminated, depending on the sex of the offspring. This was the first description of the ability of a cell to distinguish between maternal and paternal chromosomes, and Crouse used the term “imprint” to describe the phenomenon that marked a given chromosome “based solely on the sex of the germline through which the chromosome had been inherited” (Crouse, 1960).

The field of genomic imprinting follows from experiments on mammalian parthenogenotes, embryos possessing maternal but not paternal genomes. Activation of oocytes in non-mammalian species resulted in the production of viable offspring (Engelstadter, 2008). However, mammalian parthenotes are unable to complete development and die (Kaufman et al., 1977), suggesting an unequal contribution of maternal and paternal alleles. This was confirmed by further experiments constructing uniparental embryos, either from exclusively maternal or exclusively paternal DNA. Work by McGrath and Solter demonstrated that mammalian embryos generated from either two female pronuclei (gynogenotes) or two male pronuclei (androgonotes) fail to complete normal embryogenesis, dying shortly after implantation, confirming that contributions from both maternal and paternal chromosomes are necessary to support mammalian development (Markert, 1982; McGrath and Solter, 1984; Surani et al., 1984). Since then, many imprinted genes have been identified, and while general mechanisms regulating this phenomenon have been elucidated, much remains to be discovered about the control of imprinted gene expression.

### **1.2.2 Overview of Genomic Imprinting**

Genomic imprinting is a phenomenon whereby certain genes are expressed exclusively from one parental allele (Figure 1.5). To date, there are approximately 150 known imprinted genes (<http://www.mousebook.org/catalog.php?catalog=imprinting>; (Morison et al., 2005)). Imprinted genes are often found clustered together in regions known as imprinting domains, where multiple imprinted genes are under the control of





**Figure 1.5: Genomic Imprinting**

Expression from both the maternal and paternal alleles is characteristic of the majority of the genes in the genome. A subset of genes are expressed in a parent-of-origin specific manner. Some are expressed from the paternal allele, and methylated on the maternal allele, while other are expressed from the maternal allele and methylated on the paternal allele.

one or a few regulatory elements (Reinhart and Chaillet, 2005). Within imprinted domains, genes may be expressed from either the maternal or paternal allele, and, paradoxically, non-imprinted genes may be interspersed within these domains. In addition, some genes within a given imprinted domain may display imprinted expression in certain tissues, but not in others. Many imprinted genes play critical roles in the development of the embryo, or influence behaviour after birth (Varrault et al., 2006; Wilkinson et al., 2007; Champagne et al., 2009), and their dysregulation is linked to a group of human diseases called imprinting disorders.

The acquisition and maintenance of genomic imprinting is controlled through various epigenetic mechanisms. DNA methylation, histone modifications and chromatin looping all play a role in imprinted gene regulation. Imprinted domains are coordinately regulated in *cis* by DNA elements known as imprinting centers, or imprinting control regions (ICR) (Rodenhiser and Mann, 2006). These ICRs are often rich in CpG dinucleotides, which can be methylated on the 5' carbon, providing binding sites for various proteins involved in imprinting regulation (Wan and Bartolomei, 2008) and are differentially methylated depending on their parent-of-origin (Reinhart and Chaillet, 2005).

Although the specific mechanisms controlling the acquisition and maintenance of genomic imprinting at each imprinting domain is not known, research into a few key domains has led to the discovery of two key regulatory models, the insulator/enhancer model and long non-coding RNA-mediated silencing model (Wan and Bartolomei, 2008; Koerner et al., 2009) (Figure 1.6, Table 1.1).

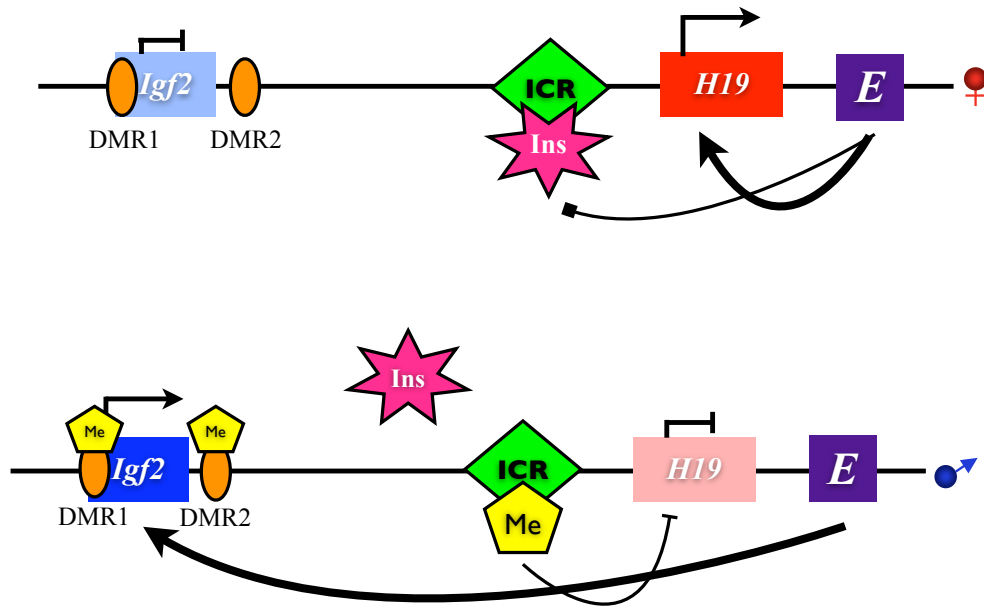
### Figure 1.6: Models of Epigenetic Regulation

(A) The *H19* imprinted domain is an example of the insulator/enhancer model of genomic imprint regulation. The maternal allele is unmethylated at the imprinting control center (ICR), allowing insulator (Ins) proteins, such as CTCF to bind. Binding of these insulator proteins prevents the interaction of the enhancer elements (E) with the upstream *Igf2* gene promoter, allowing interaction with the *H19* promoter. *H19* is expressed and *Igf2* is repressed. On the paternal allele, methylation (Me) of the ICR represses *H19* expression and prevents binding of insulator proteins. This allows the downstream enhancer elements to interact with the *Igf2* promoter, resulting in expression at this locus. Methylation spreads to the *H19* promoter, preventing interaction with the enhancers.

(B) The *Kcnq1ot1* imprinted domain is an example of the long non-coding RNA-mediated silencing model. On the maternal allele, the ICR is methylated, preventing expression of *Kcnq1ot1* non-coding RNA. Lack of expression of the long non-coding RNA results in an active domain, and expression of *Kcnq1*, *Cdkn1c* and other genes. The paternal allele is unmethylated at the ICR, allowing expression of *Kcnq1ot1*, which in turn represses of the domain.

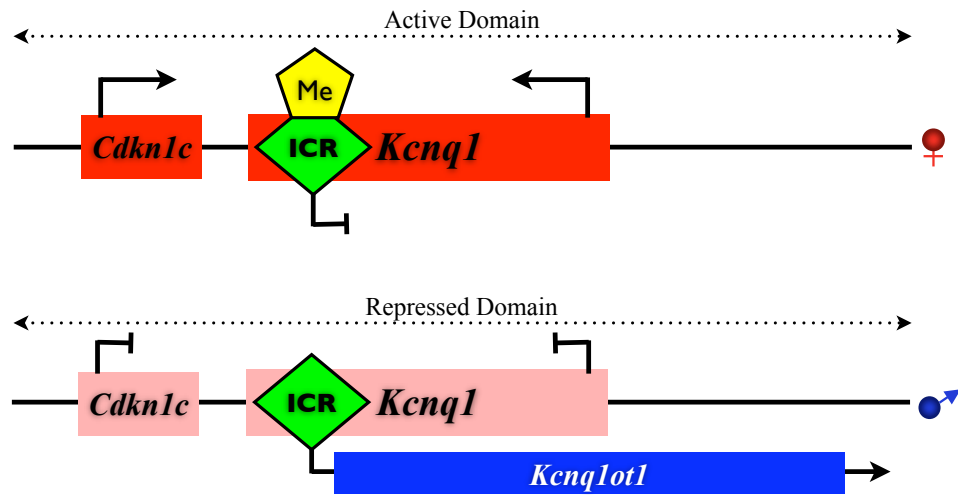
(A)

### Enhancer/Insulator Model



(B)

### Long Non-coding RNA-Mediated Silencing Model



**Table 1.1: Imprinted Genes, their Imprinted Domains and Associated Human Disorders**

<b>Gene</b>	<b>Expression</b>	<b>Regulatory Model</b>	<b>Imprinted Domain (Human)</b>	<b>Human Syndrome</b>
<i>H19</i>	Maternal	Insulator/ Enhancer	11p15.5	Beckwith- Wiedemann Syndrome, Silver-Russell Syndrome
<i>Peg1/Mest</i>	Paternal	Unknown	7q32	Silver-Russell Syndrome
<i>Snrpn</i>	Paternal	Long non- coding RNA- mediated silencing	15q11-13	Angelman Syndrome, Prader-Willi Syndrome
<i>Kcnq1ot1</i>	Paternal	Long non- coding RNA- mediated silencing	11p15.5	Beckwith- Wiedemann Syndrome
<i>Peg3</i>	Paternal	Unknown	19q13.4	None

## 1.2.3 Imprinted Domains of Interest, their Regulation and Associated Syndromes

### 1.2.3.1 *H19* Imprinted Domain 1.2.3.1.1 Structure and Regulation of the Domain

One of the first imprinting domains to be discovered, and one of the most well understood, is the *H19* imprinted domain, which is regulated through an enhancer/insulator model. This domain contains an imprinting control region (ICR), located 2 kb upstream of the *H19* transcription start site, and enhancer elements located downstream of the *H19* gene, all of which are necessary for genomic imprinting in this domain (Figure 1.6) (Srivastava et al., 2000). Differential methylation is observed at the *H19* ICR, as well as at the *Igf2* DMRs on the maternal and paternal alleles. However, only the *H19* ICR acquires gamete-derived DNA methylation. On the maternal allele, the ICR is unmethylated, allowing for binding of the insulator protein CTCF (Figure 1.6). CTCF binding forms a long-range intrachromosomal loop and recruits chromatin modifying complexes that result in repressive histone modifications at the *Igf2* promoter, suppressing gene expression (Li et al., 2008). Essentially, CTCF binding acts as an insulator, preventing the interaction between downstream enhancer elements and the upstream *Igf2* gene promoter, resulting in silencing of *Igf2*, and expression of *H19* on the maternal allele (Hark et al., 2000). On the paternal allele, DNA methylation of the upstream ICR prevents CTCF binding, allowing enhancer elements to interact with the *Igf2* gene promoter, resulting in expression of *Igf2* (Figure 1.6). Methylation at the ICR also directs methylation at the *H19* promoter, resulting in silencing of the *H19* gene (Srivastava et al., 2000; Kaffer et al., 2001).

In the mouse, four CTCF binding sites exist in the *H19* ICR. Mutation of one of these four sites results in biallelic expression of *Igf2* (Pant et al., 2004). Abolishing all four sites results in a dramatic shift in histone modifications (Han et al., 2008). On the maternal allele, there is loss of the activating modifications H3K9 acetylation and H3K4 methylation at the *H19* ICR and promoter, and loss of repressive H3K27 trimethylation at the *Igf2* promoter and DMRs. In addition, the maternal allele acquires a paternal histone configuration, with activating H3K9 acetylation and H3K4 methylation at the *Igf2* promoter and DMRs, and repressive H3K27 trimethylation at the *H19* promoter (Han et al., 2008).

Targeted deletion of the *H19* ICR results in activation of *H19* and reduced expression of *Igf2* when inherited paternally, while maternal deletion reduces *H19* expression and activates *Igf2* expression (Thorvaldsen et al., 1998). Deletion of the *H19* ICR and transcription unit of the *H19* gene (Leighton et al., 1995), or of the transcription unit alone (Ripoche et al., 1997) results in biallelic expression of *Igf2*. Phenotypic consequences of these dysregulations result in embryonic growth restriction, or an overgrowth phenotype.

#### **1.2.3.1.2 Beckwith-Wiedemann Syndrome and the *H19* Domain**

The similarity of the overgrowth phenotype noted above to the human overgrowth disorder Beckwith-Wiedemann Syndrome (BWS; OMIM #130650) led to the identification of a causative relationship between the *H19* domain and BWS. Clinically, BWS is an overgrowth disorder characterized by macroglossia, abdominal wall defects,

postnatal growth above the 90th percentile, neonatal hypoglycemia (Elliott et al., 1994) and an increased incidence of Wilm's tumour (DeBaun and Tucker, 1998; Rump et al., 2005), and is estimated to affect 1 in 13 700 children (Shuman et al., 1993). A number of studies have linked perturbations of the *H19* domain with clinical BWS in human patients (Gicquel et al., 2003; Arnaud and Feil, 2005; Chang et al., 2005; Doornbos et al., 2007). Hypermethylation of the maternal allele, microdeletions of the CTCF binding sites and resulting overexpression of *IGF2* has been shown in BWS patients, (Brown et al., 1996; Sparago et al., 2004; Prawitt et al., 2005; Cerrato et al., 2008; Riccio et al., 2009). Overall, 5% of BWS patients possess imprinting defects at the maternal *H19* imprinting center (Choufani et al., 2010).

The *H19* domain has also been implicated in the development of another imprinting disorder, Silver-Russell syndrome, discussed below (Chou et al., 2004; Kagami et al., 2007; Eggermann et al., 2010).

### **1.2.3.2 *Kcnq1ot1* Imprinted Domain**

#### **1.2.3.2.1 Structure and Regulation of the Domain**

The *Kcnq1ot1* imprinted domain is regulated by long non-coding RNA-mediated silencing, through the non-coding RNA *Kcnq1ot1*. The imprinting control region for this domain is located in intron 11 of the *Kcnq1* gene and is oriented in the antisense direction (Figure 1.6). The promoter region of *Kcnq1ot1* non-coding RNA is embedded in the ICR (Mancini-DiNardo et al., 2003; Pandey et al., 2004). The ICR is unmethylated on the



paternal allele, resulting in transcription of *Kcnq1ot1* through the imprinted domain. Recent studies from our lab have suggested that this transcript may extend up to 470 kb in length (unpublished data). It is currently unclear if the act of *Kcnq1ot1* RNA transcription through the domain results in recruitment of protein complexes that then silence the domain, or if the non-coding RNA itself plays a role in silencing of the domain, similar to the mechanism of X-inactivation through *Xist*. However, recent studies show that *Kcnq1ot1* helps to move the silenced allele into a nuclear compartment characterized by repressive histone marks (Pandey et al., 2008; Terranova et al., 2008).

Methylation at the *Kcnq1* ICR on the maternal allele results in repression of *Kcnq1ot1* transcription, allowing expression of *Kcnq1*, *Cdkn1c* and other maternally expressed genes. Further complexity exists at this domain as a number of genes display differential imprinted expression between embryonic and extraembryonic tissues (Lewis et al., 2004).

#### **1.2.3.2.2 Beckwith Wiedemann Syndrome and the *Kcnq1ot1* Domain**

Mutations of the *KCNQ1OT1* imprinted domain are thought to account for ~50% of molecular defects in patients with BWS (Weksberg et al., 2001; Cooper et al., 2005), most of which are epigenetic, and not genetic, in nature. In these cases, BWS results from loss of methylation at the *KCNQ1OT1* ICR on the maternal allele, causing biallelic expression of *KCNQ1OT1* and biallelic repression of *KCNQ1* and *CDKN1C* (Horike et al., 2000). *CDKN1C* is a cyclin-dependent kinase inhibitor, and is a negative regulator of the cell cycle (Matsuoka et al., 1996; Tsugu et al., 2000). Although the exact molecular

etiology of BWS has not yet been confirmed, *CDKN1C* is an attractive candidate gene, as ~10% of patients with BWS harbour mutations of this gene (Choufani et al., 2010).

### **1.2.3.3 *Peg1/Mest* Imprinted Domain**

#### **1.2.3.3.1 Structure and Regulation of the Domain**

The *Peg1/Mest* imprinted domain is located on mouse chromosome 6 and human chromosome 7. A CpG island spanning from the putative promoter region to exon 1 is methylated in a parent-of-origin specific manner: the maternal allele is methylated, while the paternal allele remained unmethylated (Riesewijk et al., 1997; Nishita et al., 1999). The *Peg1/Mest* imprinted domain contains three confirmed imprinted genes, two maternal (*Klf14* and *Copg2*) and one paternally expressed gene (*Peg1/Mest*).

Mechanisms regulating the *Peg1/Mest* imprinted domain remain largely unknown, however neither *YY1* nor *CTCF* are known to play a role. The only study to date investigating regulation specifically at this locus showed that *TIF1beta* and its interaction with the chromatin modifier *HPI* is essential for maintaining the repressed state of the silenced allele, characterized by DNA methylation, H4K20 trimethylation, and H3K9 trimethylation. Interestingly, this was only necessary at the repressed allele, and a loss of this interaction resulted in the silenced allele acquiring an active phenotype characterized by DNA hypomethylation, and loss of H3K9 trimethylation with gain of H3K27 trimethylation (Riclet et al., 2009).

#### **1.2.3.3.2 Silver-Russell Syndrome and the *Peg1/Mest* Domain**

Misregulation of the *PEG1/MEST* domain has been proposed as one of the causative agents of Silver-Russell Syndrome (SRS) (Hannula et al., 2001; Chou et al., 2004; Kagami et al., 2007). SRS is a growth retardation syndrome characterized by intrauterine and postnatal growth restriction, low birth weight, triangular shaped face, pointed chin and body asymmetry (Silver et al., 1953; Russell, 1954). Up to 44% of SRS cases are associated with hypomethylation of the 11p15 region (Eggermann et al., 2010), which harbours imprinted genes such as *H19* and *IGF2*, while maternal uniparental disomy of chromosome 7 is implicated in approximately 5% of cases of SRS (Kotzot et al., 1995; Eggermann et al., 2010), which harbours the *PEG1/MEST* gene. Paternal inheritance of a null *Peg1/Mest* allele results in severe IUGR in the offspring, while maternal inheritance of the null allele does not (Lefebvre et al., 1998). On the other hand, high levels of *Peg1/Mest* expression has been found in adipocytes from obese mice, and transgenic overexpression of *Peg1/Mest* results in enlargement of adipocytes (Takahashi et al., 2005). This suggests a key role for *Peg1/Mest* in regulating fetal growth.

#### **1.2.3.4 *Snrpn* Imprinted Domain**

##### **1.2.3.4.1 Structure and Regulation of the Domain**

The *Snrpn* imprinted domain contains both maternally and paternally expressed genes, and is regulated by a bipartite imprinting center located within the *Snrpn* gene. The primary imprinting center (IC) for this domain, the *Snrpn* ICR, consists of an ~35kb

region within the *Snrpn* promoter and exon 1. The *Snrpn* ICR is differentially methylated in oocytes and sperm, with maternal specific methylation maintained into adulthood (Shemer et al., 1997). Two distinct regions have been identified within this IC, PWS-IC and AS-IC, giving it a bipartite structure. Mutations in the AS-IC result in Angelman Syndrome (AS; OMIM #105830), while mutations in the PWS-IC result in Prader-Willi Syndrome (PWS; OMIM #176279). The PWS-IC is necessary for a paternal epigenetic pattern (El-Maarri et al., 2001), resulting in expression of *MKRN3*, *MAGEL2*, *NDN*, and *SNRPN*. A maternal epigenetic pattern with expression of *UBE3A* and *ATP10A* requires the AS-IC, however in the absence of both PWS- and AS-ICs a maternal epigenotype is observed (Horsthemke and Wagstaff, 2008), indicating that a maternal epigenetic pattern is the default state of this domain. The current model of regulation at the *Snrpn* imprinted domain indicates that in spermatocytes, the PWS-IC and AS-IC are unmethylated, while in oocytes, methylation at the PWS-IC is directed by protein complex (yet to be identified) binding at the AS-IC. Following fertilization, maternal methylation of the PWS-IC is maintained, while the paternal allele remains unmethylated. On the unmethylated paternal allele, *Snrpn* generates a long non-coding RNA (*Snrpn-long-transcript* [*Snrpnlt*] also known as *Ube3a-as*) that harbours a number of snoRNAs, and directs expression of the other paternally expressed genes (*Mkrn3*, *Magel2*, *Ndn*) through an unknown mechanism. Expression of the *Snrpnlt* transcript results in silencing of the *Ube3a* gene in the brain. Methylation at the PWS-IC on the maternal allele prevents activation of paternally expressed genes including the *Snrpnlt* transcript, allowing expression of *Ube3a* from the maternal allele (Horsthemke and Wagstaff, 2008).

#### 1.2.3.3.2 PWS, AS and the *Snrpn* Domain

The *SNRPN* imprinted domain was initially discovered from studies mapping the chromosomal regions implicated in Prader-Willi and Angelman Syndromes to the 15q11-13 region. It is estimated that approximately 70% of patients harbour a deletion in this region (Horsthemke, 1997). Maternally inherited deletions of the AS-IC result in the AS, and paternally inherited deletions of the PWS-IC result in PWS (Knoll et al., 1989). Maternal and paternal uniparental disomy (Nicholls et al., 1989; Mascari et al., 1992), or uniparental methylation patterns (Buiting et al., 1990; Buiting et al., 1994) have also been reported in patients that do not harbour deletions.

PWS is a neurological disorder characterized by hypotonia and failure to thrive in the neonatal period, hyperphagia in early childhood leading to obesity as well as hypogonadism, short stature, behavioural problems and varying levels of mental retardation (Goldstone, 2004). AS is a neurological disorder characterized by microcephaly, ataxia, severe mental retardation, absence of speech, sleep disorders, and seizure disorders (Williams et al., 2006). While no single gene has been found solely responsible for the development of PWS, biallelic repression of the *UBE3A* gene in the brain has been identified as the causative disruption in AS (Horsthemke and Wagstaff, 2008).

### 1.2.3.5 *Peg3* Imprinted Domain

The *Peg3* imprinted domain consists of a 500 kb region, and contains three maternally expressed (*Zim1*, *Zim2*, and *Zim3*) and 3 paternally expressed genes (*Peg3*, *Usp29*, and *Zfp264*). The transcriptional start sites of *Peg3* and *Usp29* lie very close to one another, with a bidirectional promoter in the intervening region, directing expression. A 3.8 kb region surrounding both transcriptional start sites contains a CpG island that is differentially methylated in sperm and oocytes, and is maintained into adulthood (Li et al., 2000; Huang and Kim, 2009). Methylation of the CpG island located within the *Peg3* promoter and exon 1 on the maternal allele results in repression of *Peg3* and the other paternally expressed genes, while the unmethylated paternal allele expresses these genes (Huang and Kim, 2009). Two conserved sequence elements have been identified within this 3.8 kb region and have been shown to act as binding sites for the chromatin modifier YY1 (Kim et al., 2007; Kim and Kim, 2008). Expression of YY1 is necessary for establishment of maternal methylation patterns and binding of YY1 to the maternal allele has been suggested to target the region for *de novo* methylation (Kim et al., 2009).

The *Peg3* gene is involved in modulating growth and behaviour. Loss of *Peg3* expression in mice results in growth retardation, an increase in total body fat, lower metabolic rate and lower core body temperature, and overall delayed development (Curley et al., 2005). In addition, an increase in apoptosis in the developing brain through p53-mediated pathways (Broad et al., 2009) and aberrant maternal behaviour (Champagne et al., 2009) is observed with loss of *Peg3* expression. No human imprinting disorders have been associated with aberrant imprinting of the *Peg3* locus to date.

## **1.2.4 Acquisition of Genomic Imprinting in Germ Cells**

Genomic imprints are established at different stages of development in male and female germ cells, and each imprinted domain acquires its mark at slightly different times (Figure 1.4). In primordial germ cells, a wave of DNA demethylation occurs, and imprinted methylation marks on the maternal and paternal alleles are erased (Hajkova et al., 2002; Lee et al., 2002; Yamazaki et al., 2003). Parent-of-origin specific methylation patterns are then re-established, leading to the presence of maternal-specific methylation patterns in oocytes, and paternal-specific methylation patterns in spermatocytes. Although the exact imprinting mark is unknown, thus far, DNA methylation is the most well examined, and the most likely candidate, and its pattern of acquisition in developing germ cell is well known for a number of imprinted loci (Lucifero et al., 2002).

### **1.2.4.1 Acquisition in Oocytes**

Parent-of-origin specific genomic imprints must be erased in the developing fetus in order to establish maternal genomic imprints in the developing oocyte. This erasure occurs between day 10.5 and day 11.5 in mouse primordial germ cells (Lee et al., 2002). Reestablishment of maternal DNA methylation occurs during the postnatal growth phase of oogenesis, and is complete by the MII stage (Lucifero et al., 2002). Maternally methylated ICRs acquire *de novo* methylation, while paternally methylated ICRs must be protected from methylation. In the former case, the *de novo* methyltransferase DNMT3A functions in conjunction with DNMT3L to methylate ICRs in the developing oocyte

(Hata et al., 2002; Lucifero et al., 2004). Acquisition of methylation occurs asynchronously for different imprinted loci (Lucifero et al., 2004), and this acquisition is correlated with increasing oocyte diameter (Hiura et al., 2006). The latter process is thought to occur by binding of transcription factors and other unknown proteins to the ICRs, blocking the action of the *de novo* methyltransferases at these ICRs, thereby protecting them from DNA methylation (Brandeis et al., 1994).

#### **1.2.4.2 Acquisition in Spermatocytes**

Acquisition of methylation imprints in the male germ line occurs during pre-natal development, between 15.5 and 18.5 days of gestation. Acquisition begins in prospermatogonia and is completed before the end of the pachytene phase of meiosis. (Kafri et al., 1992; Walsh et al., 1998; Davis et al., 1999; Davis et al., 2000; Ueda et al., 2000; Lees-Murdock et al., 2003). *De novo* methylation is mediated by DNMT3A and 3B, in conjunction with DNMT3L, similar to what is observed in oocytes (Kelly and Trasler, 2004). While some overlap in the function of DNMT3A and 3B has been suggested, both are required for proper imprint acquisition in the developing male germ cells (Okano et al., 1999).

#### **1.2.5 Maintenance of Genomic Imprinting**

Following fertilization, dramatic epigenetic remodeling occurs on both the maternal and paternal chromosomes, which is critical to the establishment of totipotency,



the ability of an individual embryonic cell to generate all cell types in an organism (Edwards and Beard, 1997) (Figure 1.4). Immediately after fertilization, remodeling of the sperm chromatin begins and consists of the replacement of protamines by acetylated histones, and active, genome-wide demethylation (Oswald et al., 2000). On the other hand, the maternally inherited genome is passively demethylated over the course of the next several rounds of cell division, which is thought to be due to a lack of maintenance methylation (Carlson et al., 1992). During this early stage of preimplantation development, methylation is lost from all areas of the genome except imprinted genes and retroviral sequences (Lucifero et al., 2004).

Maintenance of DNA methylation at imprinted loci relies on DNMT1, which recognizes and methylates hemi-methylated DNA (Fatemi et al., 2001). A number of isoforms of DNMT1 have been identified (Pradhan et al., 1997). The longer isoform, DNMT1s is most predominant in somatic cells (Hermann et al., 2004), while the shorter DNMT1o is present in growing oocytes and during preimplantation development (Howell et al., 2001). The majority of the time, DNMT1s is localized within the nucleus, associated with the DNA replication machinery at replication foci during S-phase (Szyf, 2001). During preimplantation development, DNMT1s is excluded from the nucleus, allowing for passive demethylation of the maternal genome (Carlson et al., 1992). The oocyte-specific isoform localizes to the nucleus at the 8-cell stage, and along with DNMT1s activity, is thought to be responsible for maintaining methylation at imprinted loci throughout preimplantation development (Ding and Chaillet, 2002). In addition, disruption of number of maternal-effect genes, that are transcribed and stored in the

developing oocyte and are required for preimplantation development, have been shown to result in loss of methylation at a number of imprinted loci including *Snrpn*, *Peg3*, *Peg1*/*Mest* and *H19* (Nakamura et al., 2007; .Li et al., 2008).

As preimplantation development proceeds, different cell lineages begin to emerge. As such, *de novo* methylation begins around the time of implantation to allow for differentiation of embryonic and extraembryonic lineages, and further differentiation into the numerous tissue types of the adult organism (Monk et al., 1987).

### **1.3 - Assisted Reproductive Technologies**

#### **1.3.1 Prevalence of ARTs and Their Sequelae**

Since the first reported birth through the use of assisted reproductive technologies (ART) in 1978, the use of these technologies has dramatically increased. It is estimated that 1-3% of total births in developed countries result from some form of ART (Klemetti et al., 2002; Wright et al., 2008). The field of assisted reproduction is broad and consists of a variety of techniques, from non-invasive procedures such as ovarian hyperstimulation, to highly invasive interventions such as intracytoplasmic sperm injection (ICSI) of retrieved oocytes. However, all involve the manipulation of human gametes and preimplantation embryos, and many involve embryo culture during preimplantation development. As described above, germ cell and preimplantation development are critical periods in the erasure and maintenance of proper imprinted methylation patterns (Santos and Dean, 2004). As such, the timing of ARTs during these

critical periods provides a mechanism for the disruption of imprinting establishment and maintenance through the environmental insult caused by the use of these procedures.

In addition to epigenetic consequences of ARTs, a number of other sequelae have been observed. Couples who undergo ART carry intrinsic subfertility, which itself is a risk factor for early pregnancy loss (Gray and Wu, 2000), and are on average 5 years older than those who conceive naturally (Katalinic et al., 2004). In addition, ART carries a higher risk of multiple births, which itself is associated with higher rates of prematurity, low birth weight, neonatal mortality, congenital malformations and disability (Koivisto et al., 1975; Fauser et al., 2005). However, all of the risk associated with ARTs cannot be attributed to intrinsic subfertility of the couples and risk of multiple births. Singleton pregnancies occurring through the use of ARTs have an increased risk of prematurity, low birth weight, neonatal mortality, and neonatal intensive care unit admission (Helmerhorst et al., 2004; Jackson et al., 2004; McDonald et al., 2005), as well as an increased risk of congenital malformations (Lancaster, 1985; Rimm et al., 2004; Bonduelle et al., 2005; Hansen et al., 2005; Klemetti et al., 2005; Olson et al., 2005), and cerebral palsy (Ericson et al., 2002; Lidegaard et al., 2005; Hvidtjorn et al., 2006) and epilepsy (Ericson et al., 2002; Sun et al., 2007). Most important for the studies contained in this thesis is the increase in the incidence of the human imprinting disorders Angelman Syndrome (AS) (Cox et al., 2002; Orstavik et al., 2003) and Beckwith-Wiedemann Syndrome (BWS) (DeBaun et al., 2003; Gicquel et al., 2003; Maher et al., 2003) with the use of ARTs.

The incidence of AS in the general population is approximately one case per 16,000 births, with only 5% of these cases related to imprinting abnormalities (Cox et al.,

2002; Williams, 2007). As the prevalence of AS is low, large-scale studies containing sufficient numbers of patients have been difficult to achieve. However, seven cases of AS following the use of ARTs have been reported to date, 5 of which displayed imprinting abnormalities (71%) (Cox et al., 2002; Orstavik et al., 2003; Ludwig et al., 2005; Sutcliffe et al., 2006). This is a significantly higher proportion than in the non-ART population.

Beckwith-Wiedemann Syndrome is a second imprinting disorder that is associated with ARTs and is estimated to affect 1 in 13 700 children (Shuman et al., 1993). As with AS, in a number of studies, parents of children with BWS were more likely to have undergone fertility treatments than the general population (Chang et al., 2005; Doornbos et al., 2007) and a higher incidence of BWS was seen in ART children than in the general population (Gicquel et al., 2003; Arnaud and Feil, 2005). The link between BWS and ARTs has been strongly established, and the relative risk of ART use is 4-9 times greater for BWS patients. Silver-Russell Syndrome has also been associated with the use of ARTs (Hitchins et al., 2001; Svensson et al., 2005; Bliet et al., 2006; Kagami et al., 2007; Galli-Tsinopoulou et al., 2008; Chopra et al., 2010). Taken all together, ARTs may impose inherent risk for normal development.

Attributing any of these risks to specific forms of ART has proven difficult, and as procedures vary from clinic to clinic, and protocols vary between patients, most studies simply group the observed effects under the umbrella of “ARTs”. The remainder of this work will focus specifically on the effects of superovulation and embryo culture on genomic imprinting.

### **1.3.2 Superovulation and Effects on Genomic Imprinting**

Superovulation, or ovarian stimulation, is the administration of exogenous hormones resulting in the concurrent maturation of a large number of ovarian follicles to produce an increased number of ovulated oocytes when compared to spontaneous ovulation (Hrometz and Gates, 2009). It is commonly used in both the treatment of human infertility (Jewelewicz, 1976; Lonergan, 2007), and in the production of livestock (Seidel, 1981) and laboratory animals (Ozgunen et al., 2001) to obtain large numbers of offspring. Ovarian stimulation regimens differ between clinics, and within clinics between patients, with varying doses and types of hormones (Reid et al., 1988; Edwards, 2007).

It has been speculated that ovarian stimulation may prevent atresia of sub-optimal follicles, leading to ovulation of low-quality oocytes (Van der Auwera and D'Hooghe, 2001), or may accelerate the growth rate of ovarian follicles (Baerwald et al., 2009). Global perturbations in DNA methylation have been observed following superovulation (Shi and Haaf, 2002). In the case of genomic imprinting, shortened oocyte maturation time may lead to improper or incomplete acquisition of imprinting marks on the maternal alleles. Loss of maternal methylation following superovulation has been observed in individual human oocytes (Sato et al., 2007; Khoueiry et al., 2008). In addition, it has been suggested that both maternal and paternal alleles may be affected by superovulation (Sato et al., 2007; Stouder et al., 2009), however, the frequency and severity of this disruption remains unknown. Regardless, for both human imprinting disorders BWS and AS, children have been identified where the only form of ARTs used in the treatment of

their parents' infertility was ovarian stimulation (Young et al., 1998; Chang et al., 2005; Ludwig et al., 2005).

### **1.3.3 Embryo Culture and Effects on Genomic Imprinting**

The suggestion that culture of the early embryo may lead to epigenetic perturbations, specifically with respect to genomic imprinting, was discovered in the mouse model. A subset of cultured embryos (analyzed in pools) displayed biallelic expression of *H19*, which was maintained in extraembryonic tissues post-implantation (Sasaki et al., 1995). Since then, it has been determined that preimplantation culture of mouse embryos results in biallelic expression of the *H19* gene and loss of imprinted methylation at the *H19*, *Snrpn*, and *Peg3* genes in blastocyst stage embryo (Doherty et al., 2000; Khosla et al., 2001; Fernandez-Gonzalez et al., 2004; Mann et al., 2004; Fauque et al., 2007). However, the extent of this effect, measured by the percent of embryos affected, varied with the type of culture medium used. This led to the hypothesis that embryo culture media vary in their ability to maintain the correct epigenetic landscape of the early embryo (Doherty et al., 2000). However, as with the previous study, the authors noted that not all embryos were affected by culture - some differences existed between embryos in their ability to compensate for the sub-optimal preimplantation environment to which they were subjected. Subsequent observations of post-implantation embryos indicated that epigenetic alterations induced by embryo culture persist. At day 9.5, following embryo culture and embryo transfer, loss of methylation and biallelic expression was observed for *H19*, *Snrpn*, *Peg3* and *Kcnq1ot1* in extraembryonic tissues,

indicating that imprinting perturbations are inherited through to midgestation, long after embryos have been removed from the culture medium (Mann et al., 2004). It is now well understood that embryo culture, the act of maintaining pre-implantation embryos outside the female reproductive tract, as well as the components of the embryo culture medium, affect genomic imprinting at multiple loci.

Significant advancements have been made in the culture of preimplantation embryos to date (Bolton et al., 1991; Fischer and Bavister, 1993; Li and Foote, 1993; Gardner, 1994; Bavister, 1995; Gardner and Lane, 1996; Bavister, 2004; Rinaudo and Schultz, 2004), and many different media are currently available. The majority of embryo culture media are based on physiological saline solutions (Quinn, 1998; Summers and Biggers, 2003). Early development of chemically-defined culture media was based on classic formulations for somatic cell culture. For example, Whitten's medium is a saline solution based on Krebs-Ringer's solution supplemented with a carbohydrate energy source. More recent formulations have adjusted concentrations of various components based either on optimized response by the embryo or to approximate values of known constituents present in the oviductal/uterine environment (Summers and Biggers, 2003). One example is KSOM (for K<sup>+</sup> modified, simplex optimized medium); identification of amino acids in oviducts led to supplementation of culture media with amino acids (AA). To date, various media types are used to culture preimplantation embryos, including in ART clinics (Gardner, 1994; Bavister, 1995; Summers and Biggers, 2003; Pool, 2004). What needs to be emphasized is that preimplantation embryos survive embryo culture by adapting to the environment (Summers and Biggers, 2003). The full consequences of

these adaptations are unknown. The fact remains that oviductal fluid is more complex and subsequently better than culture medium currently used for human and mouse embryos (Roberts, 2005). Further development of culture media was based on the idea that media components should be altered during culture to reflect the *in vivo* environment and led to the development of “sequential media systems”. Culture formulations mimic the changing environment as embryos transverse the oviduct to the uterus/uteri. Thus, a switch from high pyruvate, low glucose to high glucose, low pyruvate was implemented in these media systems to meet the temporal nutritional needs of the developing preimplantation embryo (Gardner and Lane, 1998; Cooke et al., 2002).

Many studies have attempted to show superiority of one media or another, with respect to various measures of developmental competence (Leese and Barton, 1984; Quinn et al., 1985; Ho et al., 1995; Gardner and Lane, 1998; Roberts, 2005; Lane and Gardner, 2007; Biggers and Summers, 2008). The effects of various culture media on genomic imprinting have been evaluated by many groups, however it is nearly impossible to compare between studies due to differences in other aspects of their embryo manipulation techniques. In the mouse model, M16 medium was shown to cause greater perturbation of *H19* imprinting than G1.2/G2.2 (Fauque et al., 2007). Human tubal fluid (HTF) caused loss of *H19* imprinting, including aberrant histone modifications with an increase in H3K4 dimethylation on the paternal allele and an increase in H3K9 trimethylation on the maternal allele (Li et al., 2005). KSOMaa was better able to maintain genomic imprinting than Whitten’s medium (Doherty et al., 2000; Mann et al., 2004) although culture in KSOMaa also resulted in disruptions of genomic imprinting



(Rivera et al., 2008). In the bovine, alterations in imprinting of *Snrpn* have been associated with the non-sequential SOF medium (Suzuki et al., 2005) as well as *Sgce* and *Ata3* in the sequential Vitro Cleave/Vitro Blast medium (Tveden-Nyborg et al., 2008). In humans, a recent study reported loss of methylation at the *H19* locus in ~19% of a cohort of human embryos cultured in Cleavage Medium (Chen et al., 2010), supporting the translation of aberrant imprinting noted in animal models as a caution to human embryo culture. However, all of the above studies employed ovarian stimulation to retrieve embryos prior to culture. As such, as noted above, it is not possible to tease out the effects of one type of ART from another based on the current literature. My thesis aims to provide the necessary experimental protocols and analyses to begin to elucidate the individual effects of different forms of ART.

## **1.5 - Rationale**

As described above, germ cell and preimplantation development are critical periods in the erasure, establishment and maintenance of proper imprinted methylation patterns (Santos and Dean, 2004). As such, the timing of ARTs during these critical periods provides a mechanism for the disruption of imprinting establishment and maintenance through the environmental insult caused by the use of these procedures. It is of critical importance to evaluate the effects of these techniques on genomic imprinting, and assess the safety and risks associated with each technique (Mann et al., 2004). In addition, due to the stochastic nature of environmental effects on genomic imprinting, analysis at the individual embryo levels is necessary to gain a clear understanding of the

prevalence and frequency of disruption. Multiple analyses in the same individual embryo conducted in these studies also allows for correlation of multiple characteristics with the environmental effects of genomic imprinting.

## **1.6 - Hypothesis**

I hypothesize that multiple imprinted loci are disrupted by superovulation alone or embryo culture alone, and that this disruption results from perturbations in the mechanisms regulating the acquisition and maintenance of genomic imprinting throughout preimplantation development. In addition, I hypothesize that rates of preimplantation development correlate with loss of genomic imprinting.

## **1.7 - Objectives**

This thesis addresses the following objectives:

- (1) To evaluate the effects of superovulation on genomic imprinting in the mouse embryo
- (2) To determine the differential effects of embryo culture media on genomic imprinting.
- (3) To determine the relationship between rates of preimplantation development and maintenance of genomic imprinting

All studies were performed using a technique developed during the course of my graduate work with which I was able to analyze multiple parameters in individual preimplantation embryos.

## 1.8 References

- Adenot, P. G., Mercier, Y., Renard, J. P. and Thompson, E. M. (1997) 'Differential H4 acetylation of paternal and maternal chromatin precedes DNA replication and differential transcriptional activity in pronuclei of 1-cell mouse embryos', *Development* 124(22): 4615-25.
- Anest, V., Hanson, J. L., Cogswell, P. C., Steinbrecher, K. A., Strahl, B. D. and Baldwin, A. S. (2003) 'A nucleosomal function for IkappaB kinase-alpha in NF-kappaB-dependent gene expression', *Nature* 423(6940): 659-63.
- Arnaud, P. and Feil, R. (2005) 'Epigenetic deregulation of genomic imprinting in human disorders and following assisted reproduction', *Birth Defects Res C Embryo Today* 75(2): 81-97.
- Baerwald, A. R., Walker, R. A. and Pierson, R. A. (2009) 'Growth rates of ovarian follicles during natural menstrual cycles, oral contraception cycles, and ovarian stimulation cycles', *Fertil Steril* 91(2): 440-9.
- Bavister, B. (2004) 'Oxygen concentration and preimplantation development', *Reprod Biomed Online* 9(5): 484-6.
- Bavister, B. D. (1995) 'Culture of preimplantation embryos: facts and artifacts', *Hum Reprod Update* 1(2): 91-148.
- Beaujean, N., Hartshorne, G., Cavilla, J., Taylor, J., Gardner, J., Wilmut, I., Meehan, R. and Young, L. (2004) 'Non-conservation of mammalian preimplantation methylation dynamics', *Curr Biol* 14(7): R266-7.
- Biggers, J. D. and Summers, M. C. (2008) 'Choosing a culture medium: making informed choices', *Fertil Steril* 90(3): 473-83.
- Blik, J., Terhal, P., van den Bogaard, M. J., Maas, S., Hamel, B., Salieb-Beugelaar, G., Simon, M., Letteboer, T., van der Smagt, J., Kroes, H. et al. (2006) 'Hypomethylation of the H19 gene causes not only Silver-Russell syndrome (SRS) but also isolated asymmetry or an SRS-like phenotype', *Am J Hum Genet* 78(4): 604-14.
- Bolton, V. N., Wren, M. E. and Parsons, J. H. (1991) 'Pregnancies after in vitro fertilization and transfer of human blastocysts', *Fertil Steril* 55(4): 830-2.
- Bonduelle, M., Wennerholm, U. B., Loft, A., Tarlatzis, B. C., Peters, C., Henriët, S., Mau, C., Victorin-Cederquist, A., Van Steirteghem, A., Balaska, A. et al. (2005) 'A multi-centre cohort study of the physical health of 5-year-old children conceived after intracytoplasmic sperm injection, in vitro fertilization and natural conception', *Hum Reprod* 20(2): 413-9.
- Bracken, A. P., Dietrich, N., Pasini, D., Hansen, K. H. and Helin, K. (2006) 'Genome-wide mapping of Polycomb target genes unravels their roles in cell fate transitions', *Genes Dev* 20(9): 1123-36.
- Brandeis, M., Frank, D., Keshet, I., Siegfried, Z., Mendelsohn, M., Nemes, A., Temper, V., Razin, A. and Cedar, H. (1994) 'Sp1 elements protect a CpG island from de novo methylation', *Nature* 371(6496): 435-8.

- Broad, K. D., Curley, J. P. and Keverne, E. B. (2009) 'Increased apoptosis during neonatal brain development underlies the adult behavioral deficits seen in mice lacking a functional paternally expressed gene 3 (Peg3)', *Dev Neurobiol* 69(5): 314-25.
- Brown, J. M., Leach, J., Reittie, J. E., Atzberger, A., Lee-Prudhoe, J., Wood, W. G., Higgs, D. R., Iborra, F. J. and Buckle, V. J. (2006) 'Coregulated human globin genes are frequently in spatial proximity when active', *J Cell Biol* 172(2): 177-87.
- Brown, K. W., Villar, A. J., Bickmore, W., Clayton-Smith, J., Catchpoole, D., Maher, E. R. and Reik, W. (1996) 'Imprinting mutation in the Beckwith-Wiedemann syndrome leads to biallelic IGF2 expression through an H19-independent pathway', *Hum Mol Genet* 5(12): 2027-32.
- Buiting, K., Dittrich, B., Robinson, W. P., Guitart, M., Abeliovich, D., Lerer, I. and Horsthemke, B. (1994) 'Detection of aberrant DNA methylation in unique Prader-Willi syndrome patients and its diagnostic implications', *Hum Mol Genet* 3(6): 893-5.
- Buiting, K., Neumann, M., Ludecke, H. J., Senger, G., Claussen, U., Antich, J., Passarge, E. and Horsthemke, B. (1990) 'Microdissection of the Prader-Willi syndrome chromosome region and identification of potential gene sequences', *Genomics* 6(3): 521-7.
- Carlson, L. L., Page, A. W. and Bestor, T. H. (1992) 'Properties and localization of DNA methyltransferase in preimplantation mouse embryos: implications for genomic imprinting', *Genes Dev* 6(12B): 2536-41.
- Carninci, P., Kasukawa, T., Katayama, S., Gough, J., Frith, M. C., Maeda, N., Oyama, R., Ravasi, T., Lenhard, B., Wells, C. et al. (2005) 'The transcriptional landscape of the mammalian genome', *Science* 309(5740): 1559-63.
- Cerrato, F., Sparago, A., Verde, G., De Crescenzo, A., Citro, V., Cubellis, M. V., Rinaldi, M. M., Boccuto, L., Neri, G., Magnani, C. et al. (2008) 'Different mechanisms cause imprinting defects at the IGF2/H19 locus in Beckwith-Wiedemann syndrome and Wilms' tumour', *Hum Mol Genet* 17(10): 1427-35.
- Chambeyron, S. and Bickmore, W. A. (2004) 'Chromatin decondensation and nuclear reorganization of the HoxB locus upon induction of transcription', *Genes Dev* 18(10): 1119-30.
- Champagne, F. A., Curley, J. P., Swaney, W. T., Hasen, N. S. and Keverne, E. B. (2009) 'Paternal influence on female behavior: the role of Peg3 in exploration, olfaction, and neuroendocrine regulation of maternal behavior of female mice', *Behav Neurosci* 123(3): 469-80.
- Chang, A. S., Moley, K. H., Wangler, M., Feinberg, A. P. and Debaun, M. R. (2005) 'Association between Beckwith-Wiedemann syndrome and assisted reproductive technology: a case series of 19 patients', *Fertil Steril* 83(2): 349-54.
- Chen, S. L., Shi, X. Y., Zheng, H. Y., Wu, F. R. and Luo, C. (2010) 'Aberrant DNA methylation of imprinted H19 gene in human preimplantation embryos', *Fertil Steril* 94(6): 2356-8, 2358 e1.

- Chopra, M., Amor, D. J., Sutton, L., Algar, E. and Mowat, D. (2010) 'Russell-Silver syndrome due to paternal H19/IGF2 hypomethylation in a patient conceived using intracytoplasmic sperm injection', *Reprod Biomed Online* 20(6): 843-7.
- Chou, Y. Y., Chen, C. C., Kuo, P. L., Tsai, W. H. and Lin, S. J. (2004) 'Russell-Silver syndrome: molecular diagnosis of maternal uniparental disomy of chromosome 7 using methylation-specific polymerase chain reaction assay and single nucleotide polymorphisms genotyping', *J Formos Med Assoc* 103(10): 797-802.
- Choufani, S., Shuman, C. and Weksberg, R. (2010) 'Beckwith-Wiedemann syndrome', *Am J Med Genet C Semin Med Genet* 154C(3): 343-54.
- Cooke, S., Quinn, P., Kime, L., Ayres, C., Tyler, J. P. and Driscoll, G. L. (2002) 'Improvement in early human embryo development using new formulation sequential stage-specific culture media', *Fertil Steril* 78(6): 1254-60.
- Cooper, W. N., Luharia, A., Evans, G. A., Raza, H., Haire, A. C., Grundy, R., Bowdin, S. C., Riccio, A., Sebastio, G., Bliok, J. et al. (2005) 'Molecular subtypes and phenotypic expression of Beckwith-Wiedemann syndrome', *Eur J Hum Genet* 13(9): 1025-32.
- Cowell, I. G., Aucott, R., Mahadevaiah, S. K., Burgoyne, P. S., Huskisson, N., Bongiorni, S., Prantera, G., Fanti, L., Pimpinelli, S., Wu, R. et al. (2002) 'Heterochromatin, HP1 and methylation at lysine 9 of histone H3 in animals', *Chromosoma* 111(1): 22-36.
- Cox, G. F., Burger, J., Lip, V., Mau, U. A., Sperling, K., Wu, B. L. and Horsthemke, B. (2002) 'Intracytoplasmic sperm injection may increase the risk of imprinting defects', *Am J Hum Genet* 71(1): 162-4.
- Crouse, H. V. (1960) 'The Controlling Element in Sex Chromosome Behavior in *Sciara*', *Genetics* 45(10): 1429-43.
- Curley, J. P., Pinnock, S. B., Dickson, S. L., Thresher, R., Miyoshi, N., Surani, M. A. and Keverne, E. B. (2005) 'Increased body fat in mice with a targeted mutation of the paternally expressed imprinted gene *Peg3*', *FASEB J* 19(10): 1302-4.
- Davis, T. L., Trasler, J. M., Moss, S. B., Yang, G. J. and Bartolomei, M. S. (1999) 'Acquisition of the H19 methylation imprint occurs differentially on the parental alleles during spermatogenesis', *Genomics* 58(1): 18-28.
- Davis, T. L., Yang, G. J., McCarrey, J. R. and Bartolomei, M. S. (2000) 'The H19 methylation imprint is erased and re-established differentially on the parental alleles during male germ cell development', *Hum Mol Genet* 9(19): 2885-94.
- Dean, W., Santos, F., Stojkovic, M., Zakhartchenko, V., Walter, J., Wolf, E. and Reik, W. (2001) 'Conservation of methylation reprogramming in mammalian development: aberrant reprogramming in cloned embryos', *Proc Natl Acad Sci U S A* 98(24): 13734-8.
- DeBaun, M. R., Niemitz, E. L. and Feinberg, A. P. (2003) 'Association of in vitro fertilization with Beckwith-Wiedemann syndrome and epigenetic alterations of *LIT1* and *H19*', *Am J Hum Genet* 72(1): 156-60.

- DeBaun, M. R. and Tucker, M. A. (1998) 'Risk of cancer during the first four years of life in children from The Beckwith-Wiedemann Syndrome Registry', *J Pediatr* 132(3 Pt 1): 398-400.
- Ding, F. and Chaillet, J. R. (2002) 'In vivo stabilization of the Dnmt1 (cytosine-5)-methyltransferase protein', *Proc Natl Acad Sci U S A* 99(23): 14861-6.
- Dinger, M. E., Amaral, P. P., Mercer, T. R., Pang, K. C., Bruce, S. J., Gardiner, B. B., Askarian-Amiri, M. E., Ru, K., Solda, G., Simons, C. et al. (2008) 'Long noncoding RNAs in mouse embryonic stem cell pluripotency and differentiation', *Genome Res* 18(9): 1433-45.
- Doherty, A. S., Mann, M. R., Tremblay, K. D., Bartolomei, M. S. and Schultz, R. M. (2000) 'Differential effects of culture on imprinted H19 expression in the preimplantation mouse embryo', *Biol Reprod* 62(6): 1526-35.
- Doornbos, M. E., Maas, S. M., McDonnell, J., Vermeiden, J. P. and Hennekam, R. C. (2007) 'Infertility, assisted reproduction technologies and imprinting disturbances: a Dutch study', *Hum Reprod* 22(9): 2476-80.
- Dykxhoorn, D. M., Novina, C. D. and Sharp, P. A. (2003) 'Killing the messenger: short RNAs that silence gene expression', *Nat Rev Mol Cell Biol* 4(6): 457-67.
- Edwards, R. G. (2007) 'IVF, IVM, natural cycle IVF, minimal stimulation IVF - time for a rethink', *Reprod Biomed Online* 15(1): 106-19.
- Edwards, R. G. and Beard, H. K. (1997) 'Oocyte polarity and cell determination in early mammalian embryos', *Mol Hum Reprod* 3(10): 863-905.
- Eggermann, T., Spengler, S., Bachmann, N., Baudis, M., Mau-Holzmann, U. A., Singer, S. and Rossier, E. (2010) 'Chromosome 11p15 duplication in Silver-Russell syndrome due to a maternally inherited translocation t(11;15)', *Am J Med Genet A* 152A(6): 1484-7.
- El-Maarri, O., Buiting, K., Peery, E. G., Kroisel, P. M., Balaban, B., Wagner, K., Urman, B., Heyd, J., Lich, C., Brannan, C. I. et al. (2001) 'Maternal methylation imprints on human chromosome 15 are established during or after fertilization', *Nat Genet* 27(3): 341-4.
- Elliott, M., Bayly, R., Cole, T., Temple, I. K. and Maher, E. R. (1994) 'Clinical features and natural history of Beckwith-Wiedemann syndrome: presentation of 74 new cases', *Clin Genet* 46(2): 168-74.
- Engelstadter, J. (2008) 'Constraints on the evolution of asexual reproduction', *Bioessays* 30(11-12): 1138-50.
- Ericson, A., Nygren, K. G., Olausson, P. O. and Kallen, B. (2002) 'Hospital care utilization of infants born after IVF', *Hum Reprod* 17(4): 929-32.
- Fatemi, M., Hermann, A., Pradhan, S. and Jeltsch, A. (2001) 'The activity of the murine DNA methyltransferase Dnmt1 is controlled by interaction of the catalytic domain with the N-terminal part of the enzyme leading to an allosteric activation of the enzyme after binding to methylated DNA', *J Mol Biol* 309(5): 1189-99.
- Fauque, P., Jouannet, P., Lesaffre, C., Ripoche, M. A., Dandolo, L., Vaiman, D. and Jammes, H. (2007) 'Assisted Reproductive Technology affects developmental

- kinetics, H19 Imprinting Control Region methylation and H19 gene expression in individual mouse embryos', *BMC Dev Biol* 7: 116.
- Fausser, B. C., Devroey, P. and Macklon, N. S. (2005) 'Multiple birth resulting from ovarian stimulation for subfertility treatment', *Lancet* 365(9473): 1807-16.
- Feng, J., Bi, C., Clark, B. S., Mady, R., Shah, P. and Kohtz, J. D. (2006) 'The Evf-2 noncoding RNA is transcribed from the Dlx-5/6 ultraconserved region and functions as a Dlx-2 transcriptional coactivator', *Genes Dev* 20(11): 1470-84.
- Fernandez-Gonzalez, R., Moreira, P., Bilbao, A., Jimenez, A., Perez-Crespo, M., Ramirez, M. A., Rodriguez De Fonseca, F., Pintado, B. and Gutierrez-Adan, A. (2004) 'Long-term effect of in vitro culture of mouse embryos with serum on mRNA expression of imprinting genes, development, and behavior', *Proc Natl Acad Sci U S A* 101(16): 5880-5.
- Fischer, B. and Bavister, B. D. (1993) 'Oxygen tension in the oviduct and uterus of rhesus monkeys, hamsters and rabbits', *J Reprod Fertil* 99(2): 673-9.
- Galli-Tsinopoulou, A., Emmanouilidou, E., Karagianni, P., Grigoriadou, M., Kirkos, J. and Varlamis, G. S. (2008) 'A female infant with Silver Russell Syndrome, mesocardia and enlargement of the clitoris', *Hormones (Athens)* 7(1): 77-81.
- Gardner, D. K. (1994) 'Mammalian embryo culture in the absence of serum or somatic cell support', *Cell Biol Int* 18(12): 1163-79.
- Gardner, D. K. and Lane, M. (1996) 'Alleviation of the '2-cell block' and development to the blastocyst of CF1 mouse embryos: role of amino acids, EDTA and physical parameters', *Hum Reprod* 11(12): 2703-12.
- Gardner, D. K. and Lane, M. (1998) 'Culture of viable human blastocysts in defined sequential serum-free media', *Hum Reprod* 13 Suppl 3: 148-59; discussion 160.
- Gicquel, C., Gaston, V., Mandelbaum, J., Siffroi, J. P., Flahault, A. and Le Bouc, Y. (2003) 'In vitro fertilization may increase the risk of Beckwith-Wiedemann syndrome related to the abnormal imprinting of the KCN1OT gene', *Am J Hum Genet* 72(5): 1338-41.
- Gilbert, D. M. (2002) 'Replication timing and transcriptional control: beyond cause and effect', *Curr Opin Cell Biol* 14(3): 377-83.
- Goldstone, A. P. (2004) 'Prader-Willi syndrome: advances in genetics, pathophysiology and treatment', *Trends Endocrinol Metab* 15(1): 12-20.
- Gray, R. H. and Wu, L. Y. (2000) 'Subfertility and risk of spontaneous abortion', *Am J Public Health* 90(9): 1452-4.
- Guttman, M., Amit, I., Garber, M., French, C., Lin, M. F., Feldser, D., Huarte, M., Zuk, O., Carey, B. W., Cassady, J. P. et al. (2009) 'Chromatin signature reveals over a thousand highly conserved large non-coding RNAs in mammals', *Nature* 458(7235): 223-7.
- Hajkova, P., Erhardt, S., Lane, N., Haaf, T., El-Maarri, O., Reik, W., Walter, J. and Surani, M. A. (2002) 'Epigenetic reprogramming in mouse primordial germ cells', *Mech Dev* 117(1-2): 15-23.

- Han, L., Lee, D. H. and Szabo, P. E. (2008) 'CTCF is the master organizer of domain-wide allele-specific chromatin at the H19/Igf2 imprinted region', *Mol Cell Biol* 28(3): 1124-35.
- Hannula, K., Lipsanen-Nyman, M., Kontiokari, T. and Kere, J. (2001) 'A narrow segment of maternal uniparental disomy of chromosome 7q31-qter in Silver-Russell syndrome delimits a candidate gene region', *Am J Hum Genet* 68(1): 247-53.
- Hansen, M., Bower, C., Milne, E., de Klerk, N. and Kurinczuk, J. J. (2005) 'Assisted reproductive technologies and the risk of birth defects--a systematic review', *Hum Reprod* 20(2): 328-38.
- Hark, A. T., Schoenherr, C. J., Katz, D. J., Ingram, R. S., Levorse, J. M. and Tilghman, S. M. (2000) 'CTCF mediates methylation-sensitive enhancer-blocking activity at the H19/Igf2 locus', *Nature* 405(6785): 486-9.
- Hata, K., Okano, M., Lei, H. and Li, E. (2002) 'Dnmt3L cooperates with the Dnmt3 family of de novo DNA methyltransferases to establish maternal imprints in mice', *Development* 129(8): 1983-93.
- Heard, E. and Bickmore, W. (2007) 'The ins and outs of gene regulation and chromosome territory organisation', *Curr Opin Cell Biol* 19(3): 311-6.
- Helmerhorst, F. M., Perquin, D. A., Donker, D. and Keirse, M. J. (2004) 'Perinatal outcome of singletons and twins after assisted conception: a systematic review of controlled studies', *BMJ* 328(7434): 261.
- Hermann, A., Gowher, H. and Jeltsch, A. (2004) 'Biochemistry and biology of mammalian DNA methyltransferases', *Cell Mol Life Sci* 61(19-20): 2571-87.
- Hitchins, M. P., Stanier, P., Preece, M. A. and Moore, G. E. (2001) 'Silver-Russell syndrome: a dissection of the genetic aetiology and candidate chromosomal regions', *J Med Genet* 38(12): 810-9.
- Hiura, H., Obata, Y., Komiyama, J., Shirai, M. and Kono, T. (2006) 'Oocyte growth-dependent progression of maternal imprinting in mice', *Genes Cells* 11(4): 353-61.
- Ho, Y., Wigglesworth, K., Eppig, J. J. and Schultz, R. M. (1995) 'Preimplantation development of mouse embryos in KSOM: augmentation by amino acids and analysis of gene expression', *Mol Reprod Dev* 41(2): 232-8.
- Horike, S., Mitsuya, K., Meguro, M., Kotobuki, N., Kashiwagi, A., Notsu, T., Schulz, T. C., Shirayoshi, Y. and Oshimura, M. (2000) 'Targeted disruption of the human LIT1 locus defines a putative imprinting control element playing an essential role in Beckwith-Wiedemann syndrome', *Hum Mol Genet* 9(14): 2075-83.
- Horsthemke, B. (1997) 'Structure and function of the human chromosome 15 imprinting center', *J Cell Physiol* 173(2): 237-41.
- Horsthemke, B. and Wagstaff, J. (2008) 'Mechanisms of imprinting of the Prader-Willi/Angelman region', *Am J Med Genet A* 146A(16): 2041-52.
- Howell, C. Y., Bestor, T. H., Ding, F., Latham, K. E., Mertineit, C., Trasler, J. M. and Chaillet, J. R. (2001) 'Genomic imprinting disrupted by a maternal effect mutation in the Dnmt1 gene', *Cell* 104(6): 829-38.
- Hrometz, S. L. and Gates, V. A. (2009) 'Review of available infertility treatments', *Drugs Today (Barc)* 45(4): 275-91.



- Huang, J. M. and Kim, J. (2009) 'DNA methylation analysis of the mammalian PEG3 imprinted domain', *Gene* 442(1-2): 18-25.
- Hvidtjorn, D., Grove, J., Schendel, D. E., Vaeth, M., Ernst, E., Nielsen, L. F. and Thorsen, P. (2006) 'Cerebral palsy among children born after in vitro fertilization: the role of preterm delivery--a population-based, cohort study', *Pediatrics* 118(2): 475-82.
- Jackson, R. A., Gibson, K. A., Wu, Y. W. and Croughan, M. S. (2004) 'Perinatal outcomes in singletons following in vitro fertilization: a meta-analysis', *Obstet Gynecol* 103(3): 551-63.
- Jewelewicz, R. (1976) 'Induction of ovulation: current practice and prospects', *Bull N Y Acad Med* 52(4): 466-81.
- Kaffer, C. R., Grinberg, A. and Pfeifer, K. (2001) 'Regulatory mechanisms at the mouse Igf2/H19 locus', *Mol Cell Biol* 21(23): 8189-96.
- Kafri, T., Ariel, M., Brandeis, M., Shemer, R., Urven, L., McCarrey, J., Cedar, H. and Razin, A. (1992) 'Developmental pattern of gene-specific DNA methylation in the mouse embryo and germ line', *Genes Dev* 6(5): 705-14.
- Kagami, M., Nagai, T., Fukami, M., Yamazawa, K. and Ogata, T. (2007) 'Silver-Russell syndrome in a girl born after in vitro fertilization: partial hypermethylation at the differentially methylated region of PEG1/MEST', *J Assist Reprod Genet* 24(4): 131-6.
- Kageyama, S., Liu, H., Kaneko, N., Ooga, M., Nagata, M. and Aoki, F. (2007) 'Alterations in epigenetic modifications during oocyte growth in mice', *Reproduction* 133(1): 85-94.
- Kapranov, P., Cheng, J., Dike, S., Nix, D. A., Dutttagupta, R., Willingham, A. T., Stadler, P. F., Hertel, J., Hackermuller, J., Hofacker, I. L. et al. (2007) 'RNA maps reveal new RNA classes and a possible function for pervasive transcription', *Science* 316(5830): 1484-8.
- Katalinic, A., Rosch, C. and Ludwig, M. (2004) 'Pregnancy course and outcome after intracytoplasmic sperm injection: a controlled, prospective cohort study', *Fertil Steril* 81(6): 1604-16.
- Kaufman, M. H., Barton, S. C. and Surani, M. A. (1977) 'Normal postimplantation development of mouse parthenogenetic embryos to the forelimb bud stage', *Nature* 265(5589): 53-5.
- Kelly, T. L. and Trasler, J. M. (2004) 'Reproductive epigenetics', *Clin Genet* 65(4): 247-60.
- Khalil, A. M., Guttman, M., Huarte, M., Garber, M., Raj, A., Rivea Morales, D., Thomas, K., Presser, A., Bernstein, B. E., van Oudenaarden, A. et al. (2009) 'Many human large intergenic noncoding RNAs associate with chromatin-modifying complexes and affect gene expression', *Proc Natl Acad Sci U S A* 106(28): 11667-72.
- Khosla, S., Dean, W., Brown, D., Reik, W. and Feil, R. (2001) 'Culture of preimplantation mouse embryos affects fetal development and the expression of imprinted genes', *Biol Reprod* 64(3): 918-26.

- Khoueiry, R., Ibala-Rhomdane, S., Mery, L., Blachere, T., Guerin, J. F., Lornage, J. and Lefevre, A. (2008) 'Dynamic CpG methylation of the KCNQ1OT1 gene during maturation of human oocytes', *J Med Genet* 45(9): 583-8.
- Kim, J. and Kim, J. D. (2008) 'In vivo YY1 knockdown effects on genomic imprinting', *Hum Mol Genet* 17(3): 391-401.
- Kim, J. D., Hinz, A. K., Choo, J. H., Stubbs, L. and Kim, J. (2007) 'YY1 as a controlling factor for the Peg3 and Gnas imprinted domains', *Genomics* 89(2): 262-9.
- Kim, J. D., Kang, K. and Kim, J. (2009) 'YY1's role in DNA methylation of Peg3 and Xist', *Nucleic Acids Res* 37(17): 5656-64.
- Klemetti, R., Gissler, M. and Hemminki, E. (2002) 'Comparison of perinatal health of children born from IVF in Finland in the early and late 1990s', *Hum Reprod* 17(8): 2192-8.
- Klemetti, R., Gissler, M., Sevon, T., Koivurova, S., Ritvanen, A. and Hemminki, E. (2005) 'Children born after assisted fertilization have an increased rate of major congenital anomalies', *Fertil Steril* 84(5): 1300-7.
- Knoll, J. H., Nicholls, R. D. and Lalande, M. (1989) 'On the parental origin of the deletion in Angelman syndrome', *Hum Genet* 83(2): 205-7.
- Koerner, M. V., Pauler, F. M., Huang, R. and Barlow, D. P. (2009) 'The function of non-coding RNAs in genomic imprinting', *Development* 136(11): 1771-83.
- Koivisto, M., Jouppila, P., Kauppila, A., Moilanen, I. and Ylikorkala, O. (1975) 'Twin pregnancy. Neonatal morbidity and mortality', *Acta Obstet Gynecol Scand Suppl* 44: 21-9.
- Kornberg, R. D. (1974) 'Chromatin structure: a repeating unit of histones and DNA', *Science* 184(139): 868-71.
- Kotzot, D., Schmitt, S., Bernasconi, F., Robinson, W. P., Lurie, I. W., Ilyina, H., Mehes, K., Hamel, B. C., Otten, B. J., Hergersberg, M. et al. (1995) 'Uniparental disomy 7 in Silver-Russell syndrome and primordial growth retardation', *Hum Mol Genet* 4(4): 583-7.
- Ku, M., Koche, R. P., Rheinbay, E., Mendenhall, E. M., Endoh, M., Mikkelsen, T. S., Presser, A., Nusbaum, C., Xie, X., Chi, A. S. et al. (2008) 'Genomewide analysis of PRC1 and PRC2 occupancy identifies two classes of bivalent domains', *PLoS Genet* 4(10): e1000242.
- Lancaster, P. A. (1985) 'Obstetric outcome', *Clin Obstet Gynaecol* 12(4): 847-64.
- Lane, M. and Gardner, D. K. (2007) 'Embryo culture medium: which is the best?', *Best Pract Res Clin Obstet Gynaecol* 21(1): 83-100.
- Lee, J., Inoue, K., Ono, R., Ogonuki, N., Kohda, T., Kaneko-Ishino, T., Ogura, A. and Ishino, F. (2002) 'Erasing genomic imprinting memory in mouse clone embryos produced from day 11.5 primordial germ cells', *Development* 129(8): 1807-17.
- Lee, J. T. (2010) 'The X as model for RNA's niche in epigenomic regulation', *Cold Spring Harb Perspect Biol* 2(9): a003749.
- Lees-Murdock, D. J., De Felici, M. and Walsh, C. P. (2003) 'Methylation dynamics of repetitive DNA elements in the mouse germ cell lineage', *Genomics* 82(2): 230-7.

- Leese, H. J. and Barton, A. M. (1984) 'Pyruvate and glucose uptake by mouse ova and preimplantation embryos', *J Reprod Fertil* 72(1): 9-13.
- Lefebvre, L., Viville, S., Barton, S. C., Ishino, F., Keverne, E. B. and Surani, M. A. (1998) 'Abnormal maternal behaviour and growth retardation associated with loss of the imprinted gene Mest', *Nat Genet* 20(2): 163-9.
- Lehninger, A. L., Nelson, D. L. and Cox, M. M. (2005) *Lehninger principles of biochemistry*, New York: W.H. Freeman.
- Leighton, P. A., Ingram, R. S., Eggenschwiler, J., Efstratiadis, A. and Tilghman, S. M. (1995) 'Disruption of imprinting caused by deletion of the H19 gene region in mice', *Nature* 375(6526): 34-9.
- Lepikhov, K. and Walter, J. (2004) 'Differential dynamics of histone H3 methylation at positions K4 and K9 in the mouse zygote', *BMC Dev Biol* 4: 12.
- Lewis, A., Mitsuya, K., Umlauf, D., Smith, P., Dean, W., Walter, J., Higgins, M., Feil, R. and Reik, W. (2004) 'Imprinting on distal chromosome 7 in the placenta involves repressive histone methylation independent of DNA methylation', *Nat Genet* 36(12): 1291-5.
- Li, J. and Foote, R. H. (1993) 'Culture of rabbit zygotes into blastocysts in protein-free medium with one to twenty per cent oxygen', *J Reprod Fertil* 98(1): 163-7.
- Li, L. L., Szeto, I. Y., Cattanaach, B. M., Ishino, F. and Surani, M. A. (2000) 'Organization and parent-of-origin-specific methylation of imprinted Peg3 gene on mouse proximal chromosome 7', *Genomics* 63(3): 333-40.
- Li, T., Hu, J. F., Qiu, X., Ling, J., Chen, H., Wang, S., Hou, A., Vu, T. H. and Hoffman, A. R. (2008) 'CTCF regulates allelic expression of Igf2 by orchestrating a promoter-polycomb repressive complex 2 intrachromosomal loop', *Mol Cell Biol* 28(20): 6473-82.
- Li, T., Vu, T. H., Ulaner, G. A., Littman, E., Ling, J. Q., Chen, H. L., Hu, J. F., Behr, B., Giudice, L. and Hoffman, A. R. (2005) 'IVF results in de novo DNA methylation and histone methylation at an Igf2-H19 imprinting epigenetic switch', *Mol Hum Reprod* 11(9): 631-40.
- Li X, Ito M, Zhou F, Youngson N, Zuo X, Leder P, Ferguson-Smith AC. (2008) 'A maternal-zygotic effect gene, Zfp57, maintains both maternal and paternal imprints.', *Dev Cell*. Oct;15(4):547-57.
- Lidegaard, O., Pinborg, A. and Andersen, A. N. (2005) 'Imprinting diseases and IVF: Danish National IVF cohort study', *Hum Reprod* 20(4): 950-4.
- Lonergan, P. (2007) 'State-of-the-art embryo technologies in cattle', *Soc Reprod Fertil Suppl* 64: 315-25.
- Lucifero, D., Mann, M. R., Bartolomei, M. S. and Trasler, J. M. (2004) 'Gene-specific timing and epigenetic memory in oocyte imprinting', *Hum Mol Genet* 13(8): 839-49.
- Lucifero, D., Mertineit, C., Clarke, H. J., Bestor, T. H. and Trasler, J. M. (2002) 'Methylation dynamics of imprinted genes in mouse germ cells', *Genomics* 79(4): 530-8.

- Ludwig, M., Katalinic, A., Gross, S., Sutcliffe, A., Varon, R. and Horsthemke, B. (2005) 'Increased prevalence of imprinting defects in patients with Angelman syndrome born to subfertile couples', *J Med Genet* 42(4): 289-91.
- Maher, E. R., Brueton, L. A., Bowdin, S. C., Luharia, A., Cooper, W., Cole, T. R., Macdonald, F., Sampson, J. R., Barratt, C. L., Reik, W. et al. (2003) 'Beckwith-Wiedemann syndrome and assisted reproduction technology (ART)', *J Med Genet* 40(1): 62-4.
- Mahy, N. L., Perry, P. E. and Bickmore, W. A. (2002) 'Gene density and transcription influence the localization of chromatin outside of chromosome territories detectable by FISH', *J Cell Biol* 159(5): 753-63.
- Mancini-DiNardo, D., Steele, S. J., Ingram, R. S. and Tilghman, S. M. (2003) 'A differentially methylated region within the gene *Kcnq1* functions as an imprinted promoter and silencer', *Hum Mol Genet* 12(3): 283-94.
- Mancini-Dinardo, D., Steele, S. J., Levorse, J. M., Ingram, R. S. and Tilghman, S. M. (2006) 'Elongation of the *Kcnq1ot1* transcript is required for genomic imprinting of neighboring genes', *Genes Dev* 20(10): 1268-82.
- Mann, M. R., Lee, S. S., Doherty, A. S., Verona, R. I., Nolen, L. D., Schultz, R. M. and Bartolomei, M. S. (2004) 'Selective loss of imprinting in the placenta following preimplantation development in culture', *Development* 131(15): 3727-35.
- Markert, C. L. (1982) 'Parthenogenesis, homozygosity, and cloning in mammals', *J Hered* 73(6): 390-7.
- Mascari, M. J., Gottlieb, W., Rogan, P. K., Butler, M. G., Waller, D. A., Armour, J. A., Jeffreys, A. J., Ladda, R. L. and Nicholls, R. D. (1992) 'The frequency of uniparental disomy in Prader-Willi syndrome. Implications for molecular diagnosis', *N Engl J Med* 326(24): 1599-607.
- Matsuoka, S., Thompson, J. S., Edwards, M. C., Bartletta, J. M., Grundy, P., Kalikin, L. M., Harper, J. W., Elledge, S. J. and Feinberg, A. P. (1996) 'Imprinting of the gene encoding a human cyclin-dependent kinase inhibitor, p57KIP2, on chromosome 11p15', *Proc Natl Acad Sci U S A* 93(7): 3026-30.
- Mayer, W., Niveleau, A., Walter, J., Fundele, R. and Haaf, T. (2000) 'Demethylation of the zygotic paternal genome', *Nature* 403(6769): 501-2.
- McDonald, S. D., Murphy, K., Beyene, J. and Ohlsson, A. (2005) 'Perinatal outcomes of singleton pregnancies achieved by in vitro fertilization: a systematic review and meta-analysis', *J Obstet Gynaecol Can* 27(5): 449-59.
- McGrath, J. and Solter, D. (1984) 'Completion of mouse embryogenesis requires both the maternal and paternal genomes', *Cell* 37(1): 179-83.
- Mohammad, F., Pandey, R. R., Nagano, T., Chakalova, L., Mondal, T., Fraser, P. and Kanduri, C. (2008) 'Kcnq1ot1/Lit1 noncoding RNA mediates transcriptional silencing by targeting to the perinucleolar region', *Mol Cell Biol* 28(11): 3713-28.
- Monk, M., Boubelik, M. and Lehnert, S. (1987) 'Temporal and regional changes in DNA methylation in the embryonic, extraembryonic and germ cell lineages during mouse embryo development', *Development* 99(3): 371-82.

- Morgan, H. D., Santos, F., Green, K., Dean, W. and Reik, W. (2005) 'Epigenetic reprogramming in mammals', *Hum Mol Genet* 14 Spec No 1: R47-58.
- Morison, I. M., Ramsay, J. P. and Spencer, H. G. (2005) 'A census of mammalian imprinting', *Trends Genet* 21(8): 457-65.
- Nagano, T., Mitchell, J. A., Sanz, L. A., Pauler, F. M., Ferguson-Smith, A. C., Feil, R. and Fraser, P. (2008) 'The Air noncoding RNA epigenetically silences transcription by targeting G9a to chromatin', *Science* 322(5908): 1717-20.
- Nicholls, R. D., Knoll, J. H., Butler, M. G., Karam, S. and Lalonde, M. (1989) 'Genetic imprinting suggested by maternal heterodisomy in nondeletion Prader-Willi syndrome', *Nature* 342(6247): 281-5.
- Nishita, Y., Sado, T., Yoshida, I. and Takagi, N. (1999) 'Effect of CpG methylation on expression of the mouse imprinted gene Mest', *Gene* 226(2): 199-209.
- Okano, M., Bell, D. W., Haber, D. A. and Li, E. (1999) 'DNA methyltransferases Dnmt3a and Dnmt3b are essential for de novo methylation and mammalian development', *Cell* 99(3): 247-57.
- Okano, M., Xie, S. and Li, E. (1998) 'Cloning and characterization of a family of novel mammalian DNA (cytosine-5) methyltransferases', *Nat Genet* 19(3): 219-20.
- Olson, C. K., Keppler-Noreuil, K. M., Romitti, P. A., Budelier, W. T., Ryan, G., Sparks, A. E. and Van Voorhis, B. J. (2005) 'In vitro fertilization is associated with an increase in major birth defects', *Fertil Steril* 84(5): 1308-15.
- Orstavik, K. H., Eiklid, K., van der Hagen, C. B., Spetalen, S., Kierulf, K., Skjeldal, O. and Buiting, K. (2003) 'Another case of imprinting defect in a girl with Angelman syndrome who was conceived by intracytoplasmic semen injection', *Am J Hum Genet* 72(1): 218-9.
- Oswald, J., Engemann, S., Lane, N., Mayer, W., Olek, A., Fundele, R., Dean, W., Reik, W. and Walter, J. (2000) 'Active demethylation of the paternal genome in the mouse zygote', *Curr Biol* 10(8): 475-8.
- Ozgunen, K. T., Erdogan, S., Mazmanoglu, N., Pamuk, I., Logoglu, G. and Ozgunen, T. (2001) 'Effect of gonadotrophin dose on oocyte retrieval in superovulated BALB/c mice', *Theriogenology* 56(3): 435-45.
- Pandey, R. R., Ceribelli, M., Singh, P. B., Ericsson, J., Mantovani, R. and Kanduri, C. (2004) 'NF-Y regulates the antisense promoter, bidirectional silencing, and differential epigenetic marks of the Kcnq1 imprinting control region', *J Biol Chem* 279(50): 52685-93.
- Pandey, R. R., Mondal, T., Mohammad, F., Enroth, S., Redrup, L., Komorowski, J., Nagano, T., Mancini-Dinardo, D. and Kanduri, C. (2008) 'Kcnq1ot1 antisense noncoding RNA mediates lineage-specific transcriptional silencing through chromatin-level regulation', *Mol Cell* 32(2): 232-46.
- Pant, V., Kurukuti, S., Pugacheva, E., Shamsuddin, S., Mariano, P., Renkawitz, R., Klenova, E., Lobanenkova, V. and Ohlsson, R. (2004) 'Mutation of a single CTCF target site within the H19 imprinting control region leads to loss of Igf2 imprinting and complex patterns of de novo methylation upon maternal inheritance', *Mol Cell Biol* 24(8): 3497-504.

- Pool, T. B. (2004) 'Development of culture media for human assisted reproductive technology', *Fertil Steril* 81(2): 287-9.
- Pradhan, S., Talbot, D., Sha, M., Benner, J., Hornstra, L., Li, E., Jaenisch, R. and Roberts, R. J. (1997) 'Baculovirus-mediated expression and characterization of the full-length murine DNA methyltransferase', *Nucleic Acids Res* 25(22): 4666-73.
- Prawitt, D., Enklaar, T., Gartner-Rupprecht, B., Spangenberg, C., Oswald, M., Lausch, E., Schmidtke, P., Reutzel, D., Fees, S., Lucito, R. et al. (2005) 'Microdeletion of target sites for insulator protein CTCF in a chromosome 11p15 imprinting center in Beckwith-Wiedemann syndrome and Wilms' tumor', *Proc Natl Acad Sci U S A* 102(11): 4085-90.
- Quinn, P. (1998) 'Glucose and phosphate--important or unimportant in culture media for embryos?', *Fertil Steril* 70(4): 782-3.
- Quinn, P., Kerin, J. F. and Warnes, G. M. (1985) 'Improved pregnancy rate in human in vitro fertilization with the use of a medium based on the composition of human tubal fluid', *Fertil Steril* 44(4): 493-8.
- Reid, R. L., Fretts, R. and Van Vugt, D. A. (1988) 'The theory and practice of ovulation induction with gonadotropin-releasing hormone', *Am J Obstet Gynecol* 158(1): 176-85.
- Reinhart, B. and Chaillet, J. R. (2005) 'Genomic imprinting: cis-acting sequences and regional control', *Int Rev Cytol* 243: 173-213.
- Riccio, A., Sparago, A., Verde, G., De Crescenzo, A., Citro, V., Cubellis, M. V., Ferrero, G. B., Silengo, M. C., Russo, S., Larizza, L. et al. (2009) 'Inherited and Sporadic Epimutations at the IGF2-H19 locus in Beckwith-Wiedemann syndrome and Wilms' tumor', *Endocr Dev* 14: 1-9.
- Riclet, R., Chendeb, M., Vonesch, J. L., Koczan, D., Thiesen, H. J., Losson, R. and Cammas, F. (2009) 'Disruption of the interaction between transcriptional intermediary factor 1 {beta} and heterochromatin protein 1 leads to a switch from DNA hyper- to hypomethylation and H3K9 to H3K27 trimethylation on the MEST promoter correlating with gene reactivation', *Mol Biol Cell* 20(1): 296-305.
- Riesewijk, A. M., Hu, L., Schulz, U., Tariverdian, G., Hoglund, P., Kere, J., Ropers, H. H. and Kalscheuer, V. M. (1997) 'Monoallelic expression of human PEG1/MEST is paralleled by parent-specific methylation in fetuses', *Genomics* 42(2): 236-44.
- Rimm, A. A., Katayama, A. C., Diaz, M. and Katayama, K. P. (2004) 'A meta-analysis of controlled studies comparing major malformation rates in IVF and ICSI infants with naturally conceived children', *J Assist Reprod Genet* 21(12): 437-43.
- Rinaudo, P. and Schultz, R. M. (2004) 'Effects of embryo culture on global pattern of gene expression in preimplantation mouse embryos', *Reproduction* 128(3): 301-11.
- Rinn, J. L., Kertesz, M., Wang, J. K., Squazzo, S. L., Xu, X., Bruggmann, S. A., Goodnough, L. H., Helms, J. A., Farnham, P. J., Segal, E. et al. (2007) 'Functional demarcation of active and silent chromatin domains in human HOX loci by noncoding RNAs', *Cell* 129(7): 1311-23.

- Ripoche, M. A., Kress, C., Poirier, F. and Dandolo, L. (1997) 'Deletion of the H19 transcription unit reveals the existence of a putative imprinting control element', *Genes Dev* 11(12): 1596-604.
- Rivera, R. M., Stein, P., Weaver, J. R., Mager, J., Schultz, R. M. and Bartolomei, M. S. (2008) 'Manipulations of mouse embryos prior to implantation result in aberrant expression of imprinted genes on day 9.5 of development', *Hum Mol Genet* 17(1): 1-14.
- Roberts, R. M. (2005) 'Embryo culture conditions: what embryos like best', *Endocrinology* 146(5): 2140-1.
- Rodenhiser, D. and Mann, M. (2006) 'Epigenetics and human disease: translating basic biology into clinical applications', *CMAJ* 174(3): 341-8.
- Rougier, N., Bourc'his, D., Gomes, D. M., Niveleau, A., Plachot, M., Paldi, A. and Viegas-Pequignot, E. (1998) 'Chromosome methylation patterns during mammalian preimplantation development', *Genes Dev* 12(14): 2108-13.
- Rump, P., Zeegers, M. P. and van Essen, A. J. (2005) 'Tumor risk in Beckwith-Wiedemann syndrome: A review and meta-analysis', *Am J Med Genet A* 136(1): 95-104.
- Russell, A. (1954) 'A syndrome of intra-uterine dwarfism recognizable at birth with cranio-facial dysostosis, disproportionately short arms, and other anomalies (5 examples)', *Proc R Soc Med* 47(12): 1040-4.
- Santos, F. and Dean, W. (2004) 'Epigenetic reprogramming during early development in mammals', *Reproduction* 127(6): 643-51.
- Santos, F., Hendrich, B., Reik, W. and Dean, W. (2002) 'Dynamic reprogramming of DNA methylation in the early mouse embryo', *Dev Biol* 241(1): 172-82.
- Sasaki, H., Ferguson-Smith, A. C., Shum, A. S., Barton, S. C. and Surani, M. A. (1995) 'Temporal and spatial regulation of H19 imprinting in normal and uniparental mouse embryos', *Development* 121(12): 4195-202.
- Sassone-Corsi, P., Mizzen, C. A., Cheung, P., Crosio, C., Monaco, L., Jacquot, S., Hanauer, A. and Allis, C. D. (1999) 'Requirement of Rsk-2 for epidermal growth factor-activated phosphorylation of histone H3', *Science* 285(5429): 886-91.
- Sato, A., Otsu, E., Negishi, H., Utsunomiya, T. and Arima, T. (2007) 'Aberrant DNA methylation of imprinted loci in superovulated oocytes', *Hum Reprod* 22(1): 26-35.
- Schar, P. and Fritsch, O. (2011) 'DNA repair and the control of DNA methylation', *Prog Drug Res* 67: 51-68.
- Schiltz, R. L., Mizzen, C. A., Vassilev, A., Cook, R. G., Allis, C. D. and Nakatani, Y. (1999) 'Overlapping but distinct patterns of histone acetylation by the human coactivators p300 and PCAF within nucleosomal substrates', *J Biol Chem* 274(3): 1189-92.
- Schultz, R. M. (2002) 'The molecular foundations of the maternal to zygotic transition in the preimplantation embryo', *Hum Reprod Update* 8(4): 323-31.
- Seidel, G. E., Jr. (1981) 'Superovulation and embryo transfer in cattle', *Science* 211(4480): 351-8.

- Shemer, R., Birger, Y., Riggs, A. D. and Razin, A. (1997) 'Structure of the imprinted mouse *Snrpn* gene and establishment of its parental-specific methylation pattern', *Proc Natl Acad Sci U S A* 94(19): 10267-72.
- Shopland, L. S., Lynch, C. R., Peterson, K. A., Thornton, K., Kepper, N., Hase, J., Stein, S., Vincent, S., Molloy, K. R., Kreth, G. et al. (2006) 'Folding and organization of a contiguous chromosome region according to the gene distribution pattern in primary genomic sequence', *J Cell Biol* 174(1): 27-38.
- Shuman, C., Beckwith, J. B., Smith, A. C. and Weksberg, R. (1993) 'Beckwith-Wiedemann Syndrome'.
- Silver, H. K., Kiyasu, W., George, J. and Deamer, W. C. (1953) 'Syndrome of congenital hemihypertrophy, shortness of stature, and elevated urinary gonadotropins', *Pediatrics* 12(4): 368-76.
- Sparago, A., Cerrato, F., Vernucci, M., Ferrero, G. B., Silengo, M. C. and Riccio, A. (2004) 'Microdeletions in the human H19 DMR result in loss of IGF2 imprinting and Beckwith-Wiedemann syndrome', *Nat Genet* 36(9): 958-60.
- Srivastava, M., Hsieh, S., Grinberg, A., Williams-Simons, L., Huang, S. P. and Pfeifer, K. (2000) 'H19 and *Igf2* monoallelic expression is regulated in two distinct ways by a shared cis acting regulatory region upstream of H19', *Genes Dev* 14(10): 1186-95.
- Stouder, C., Deutsch, S. and Paoloni-Giacobino, A. (2009) 'Superovulation in mice alters the methylation pattern of imprinted genes in the sperm of the offspring', *Reprod Toxicol* 28(4): 536-41.
- Summers, M. C. and Biggers, J. D. (2003) 'Chemically defined media and the culture of mammalian preimplantation embryos: historical perspective and current issues', *Hum Reprod Update* 9(6): 557-82.
- Sun, Y., Vestergaard, M., Christensen, J., Zhu, J. L., Bech, B. H. and Olsen, J. (2007) 'Epilepsy and febrile seizures in children of treated and untreated subfertile couples', *Hum Reprod* 22(1): 215-20.
- Surani, M. A., Barton, S. C. and Norris, M. L. (1984) 'Development of reconstituted mouse eggs suggests imprinting of the genome during gametogenesis', *Nature* 308(5959): 548-50.
- Sutcliffe, A. G., Peters, C. J., Bowdin, S., Temple, K., Reardon, W., Wilson, L., Clayton-Smith, J., Brueton, L. A., Bannister, W. and Maher, E. R. (2006) 'Assisted reproductive therapies and imprinting disorders--a preliminary British survey', *Hum Reprod* 21(4): 1009-11.
- Suzuki, S., Renfree, M. B., Pask, A. J., Shaw, G., Kobayashi, S., Kohda, T., Kaneko-Ishino, T. and Ishino, F. (2005) 'Genomic imprinting of IGF2, p57(KIP2) and PEG1/MEST in a marsupial, the tammar wallaby', *Mech Dev* 122(2): 213-22.
- Svensson, J., Bjornstahl, A. and Ivarsson, S. A. (2005) 'Increased risk of Silver-Russell syndrome after in vitro fertilization?', *Acta Paediatr* 94(8): 1163-5.
- Szyf, M. (2001) 'The role of DNA methyltransferase 1 in growth control', *Front Biosci* 6: D599-609.



- Takahashi, M., Kamei, Y. and Ezaki, O. (2005) 'Mest/Peg1 imprinted gene enlarges adipocytes and is a marker of adipocyte size', *Am J Physiol Endocrinol Metab* 288(1): E117-24.
- Terranova, R., Yokobayashi, S., Stadler, M. B., Otte, A. P., van Lohuizen, M., Orkin, S. H. and Peters, A. H. (2008) 'Polycomb group proteins Ezh2 and Rnf2 direct genomic contraction and imprinted repression in early mouse embryos', *Dev Cell* 15(5): 668-79.
- Thorvaldsen, J. L., Duran, K. L. and Bartolomei, M. S. (1998) 'Deletion of the H19 differentially methylated domain results in loss of imprinted expression of H19 and Igf2', *Genes Dev* 12(23): 3693-702.
- Tsugu, A., Sakai, K., Dirks, P. B., Jung, S., Weksberg, R., Fei, Y. L., Mondal, S., Ivanchuk, S., Ackerley, C., Hamel, P. A. et al. (2000) 'Expression of p57(KIP2) potently blocks the growth of human astrocytomas and induces cell senescence', *Am J Pathol* 157(3): 919-32.
- Turner, B. M. and Fellows, G. (1989) 'Specific antibodies reveal ordered and cell-cycle-related use of histone-H4 acetylation sites in mammalian cells', *Eur J Biochem* 179(1): 131-9.
- Tveden-Nyborg, P. Y., Alexopoulos, N. I., Cooney, M. A., French, A. J., Tecirlioglu, R. T., Holland, M. K., Thomsen, P. D. and D'Cruz, N. T. (2008) 'Analysis of the expression of putatively imprinted genes in bovine peri-implantation embryos', *Theriogenology* 70(7): 1119-28.
- Ueda, T., Abe, K., Miura, A., Yuzuriha, M., Zubair, M., Noguchi, M., Niwa, K., Kawase, Y., Kono, T., Matsuda, Y. et al. (2000) 'The paternal methylation imprint of the mouse H19 locus is acquired in the gonocyte stage during foetal testis development', *Genes Cells* 5(8): 649-59.
- Van der Auwera, I. and D'Hooghe, T. (2001) 'Superovulation of female mice delays embryonic and fetal development', *Hum Reprod* 16(6): 1237-43.
- Van Speybroeck, L. (2002) 'From epigenesis to epigenetics: the case of C. H. Waddington', *Ann N Y Acad Sci* 981: 61-81.
- Vaquero, A., Scher, M., Lee, D., Erdjument-Bromage, H., Tempst, P. and Reinberg, D. (2004) 'Human SirT1 interacts with histone H1 and promotes formation of facultative heterochromatin', *Mol Cell* 16(1): 93-105.
- Varrault, A., Gueydan, C., Delalbre, A., Bellmann, A., Houssami, S., Aknin, C., Severac, D., Chotard, L., Kahli, M., Le Digarcher, A. et al. (2006) 'Zac1 regulates an imprinted gene network critically involved in the control of embryonic growth', *Dev Cell* 11(5): 711-22.
- Waddington, C. H. (1939) *An introduction to modern genetics*, New York,: The Macmillan company.
- Walsh, C. P., Chaillet, J. R. and Bestor, T. H. (1998) 'Transcription of IAP endogenous retroviruses is constrained by cytosine methylation', *Nat Genet* 20(2): 116-7.
- Wan, L. B. and Bartolomei, M. S. (2008) 'Regulation of imprinting in clusters: noncoding RNAs versus insulators', *Adv Genet* 61: 207-23.

- Wang, X., Arai, S., Song, X., Reichart, D., Du, K., Pascual, G., Tempst, P., Rosenfeld, M. G., Glass, C. K. and Kurokawa, R. (2008) 'Induced ncRNAs allosterically modify RNA-binding proteins in cis to inhibit transcription', *Nature* 454(7200): 126-30.
- Weksberg, R., Nishikawa, J., Caluseriu, O., Fei, Y. L., Shuman, C., Wei, C., Steele, L., Cameron, J., Smith, A., Ambus, I. et al. (2001) 'Tumor development in the Beckwith-Wiedemann syndrome is associated with a variety of constitutional molecular 11p15 alterations including imprinting defects of KCNQ1OT1', *Hum Mol Genet* 10(26): 2989-3000.
- Wilkinson, L. S., Davies, W. and Isles, A. R. (2007) 'Genomic imprinting effects on brain development and function', *Nat Rev Neurosci* 8(11): 832-43.
- Williams, C. A., Beaudet, A. L., Clayton-Smith, J., Knoll, J. H., Kyllerman, M., Laan, L. A., Magenis, R. E., Moncla, A., Schinzel, A. A., Summers, J. A. et al. (2006) 'Angelman syndrome 2005: updated consensus for diagnostic criteria', *Am J Med Genet A* 140(5): 413-8.
- Williams, M. S. (2007) 'Adult dysmorphism: perspectives on approach to diagnosis and care', *Am J Med Genet C Semin Med Genet* 145C(3): 227-9.
- Wright, V. C., Chang, J., Jeng, G. and Macaluso, M. (2008) 'Assisted reproductive technology surveillance--United States, 2005', *MMWR Surveill Summ* 57(5): 1-23.
- Wurtele, H. and Chartrand, P. (2006) 'Genome-wide scanning of HoxB1-associated loci in mouse ES cells using an open-ended Chromosome Conformation Capture methodology', *Chromosome Res* 14(5): 477-95.
- Yamazaki, Y., Mann, M. R., Lee, S. S., Marh, J., McCarrey, J. R., Yanagimachi, R. and Bartolomei, M. S. (2003) 'Reprogramming of primordial germ cells begins before migration into the genital ridge, making these cells inadequate donors for reproductive cloning', *Proc Natl Acad Sci U S A* 100(21): 12207-12.
- Young, E., Kenny, A., Puigdomenech, E., Van Thillo, G., Tiveron, M. and Piazza, A. (1998) 'Triplet pregnancy after intracytoplasmic sperm injection of cryopreserved oocytes: case report', *Fertil Steril* 70(2): 360-1.
- Zhao, J., Sun, B. K., Erwin, J. A., Song, J. J. and Lee, J. T. (2008) 'Polycomb proteins targeted by a short repeat RNA to the mouse X chromosome', *Science* 322(5902): 750-6.
- Zirbel, R. M., Mathieu, U. R., Kurz, A., Cremer, T. and Lichter, P. (1993) 'Evidence for a nuclear compartment of transcription and splicing located at chromosome domain boundaries', *Chromosome Res* 1(2): 93-106.

## **Chapter 2: The Effects of Superovulation on Genomic Imprinting**

The work in this chapter originates from the following peer-reviewed article:

Market-Velker, B.A., Zhang, L., Magri, L.S., Bonvissuto, A.C. & Mann, M.R. Dual effects of superovulation: loss of maternal and paternal imprinted methylation in a dose-dependent manner. *Hum Mol Genet* 19, 36-51 (2010).

### **2.1 Introduction**

The use of assisted reproductive technologies (ARTs) for the treatment of human subfertility / infertility contributes 1-2% of all children born in developed countries (Gosden et al., 2003; Roberts, 2005). However, the safety of these technologies has yet to be fully evaluated. Children conceived through various forms of ART are at an increased risk of low birth weight, intrauterine growth restriction, premature birth, and have a higher incidence of genetic and epigenetic disorders, including genomic imprinting disorders such as Beckwith-Wiedemann Syndrome and Angelman Syndrome (Cox et al., 2002; DeBaun et al., 2003; Gicquel et al., 2003; Maher et al., 2003; Orstavik et al., 2003; Sunderam et al., 2009). While the absolute risk of developing a genomic imprinting disorder in children born through ART as a result of an epigenetic defect is low, the relative risk when compared to non-ART children is significantly higher (Maher, 2005; Bowdin et al., 2007).

Genomic imprinting is a mechanism of transcriptional regulation that restricts expression to either the maternally- or paternally-inherited copy of the gene; the opposite

parental copy is silent (Verona et al., 2003). Imprinting may be envisaged as a multi-generational process that begins in parental gametes, where previous DNA modifications are erased, and sex-specific modifications that differentially mark the parental alleles are acquired (Szabo and Mann, 1995; Kato et al., 1999; Lee et al., 2002). Maternal imprints are established in the oocyte, during maturation from primordial to antral follicles. Imprinting marks are then stably inherited and maintained in the developing embryo, amidst genome-wide changes in DNA methylation, where they are translated into parental-specific monoallelic expression (Pfeifer, 2000). Disruptions in any of these steps may lead to loss of parental-specific expression and the development of imprinting disorders.

DNA methylation of CpG dinucleotides is the most widely investigated epigenetic "mark" associated with genomic imprinting. It has generally been linked to transcriptional repression, is both heritable and reversible, and has been shown to interact with, and recruit, chromatin-modifying complexes to silence or activate specific genes (Razin and Riggs, 1980; Berger, 2007; Cedar and Bergman, 2009). DNA methylation occurs at regions called differentially methylated regions (DMRs) that display differential methylation of maternal and paternal alleles, or imprinting control regions (ICRs), if it has been ascertained that differential methylation is acquired during gametogenesis and maintained during preimplantation development. Although the exact mechanisms of imprinted gene regulation have yet to be elucidated, DNA methylation at DMR/ICRs has been correlated with allelic expression of many imprinted genes (Verona et al., 2003).

Superovulation, or ovarian stimulation, is an assisted reproductive technology commonly used to treat subfertility in women, for basic research in animal models, and in the production of livestock to obtain large numbers of offspring. Increased frequencies of imprinting disorders have been correlated with ARTs, and loss of imprinting is more often the cause of imprinting disorders in affected ART populations than in non-ART children. Significantly, for both Angelman and Beckwith-Wiedemann Syndromes, patients have been identified where the only ART procedure used was ovarian stimulation (Young et al., 1998; Chang et al., 2005; Ludwig et al., 2005).

To distinguish between the effects of superovulation and other contributing factors on genomic imprinting, carefully controlled experiments are required on spontaneously-ovulated, *in vivo*-fertilized oocytes, and their induced-ovulated counterparts, thereby minimizing effects of *in vitro* manipulations. Additionally, effects of superovulation on genomic imprinting need to be evaluated in an animal model system, where subfertility is not a confounding issue.

We propose that superovulation alone increases the risk of developing imprinting disorders. To address this, we evaluated imprinted methylation of multiple genes from individual mouse preimplantation embryos. This work represents the first comprehensive examination of the overall effect of ovarian stimulation on genomic DNA methylation imprints at four imprinted loci, *Snrpn*, *Peg3*, *Kcnq1ot1* and *H19*, in individual blastocyst stage embryos, and is the first to utilize low and high doses of hormones to assess their effects on genomic imprinting. We report that superovulation resulted in a loss of *Snrpn*, *Peg3* and *Kcnq1ot1* imprinted methylation, and a gain of imprinted *H19* methylation in

preimplantation embryos, and that this perturbation was dose-dependent; dysregulation of imprinted methylation was more frequent at the high hormone dosage. Additionally, we show that maternal- as well as paternal-specific *H19* methylation imprints were perturbed by superovulation, suggesting that superovulation disrupts acquisition of imprints in growing oocytes, as well as maternal-effect gene products subsequently required for imprint maintenance during preimplantation development.

## **2.2 Methods**

### **2.2.1 Ovarian Stimulation and Embryo Collection**

Embryos were obtained from crosses of C57BL/6 (CAST7) females and C57BL/6 (B6) males (Jackson Laboratory or Charles River). B6(CAST7) mice contain *Mus musculus castaneus* chromosome 7 on a B6 background (Mann et al., 2003). Two hormone regimens were used for ovarian stimulation, 6.25 IU (low dose) and 10 IU (high dose). Low or high doses of PMSG (Pregnant Mare's Serum Gonadotropin, Intervet Canada) were administered to female B6(CAST7) mice, followed by the same dose of hCG (Human Serum Chorionic Gonadotropin, Intervet Canada) 40-44 hours later. Females were mated with B6 males, and pregnancy was determined by the presence of a vaginal plug the following morning (day 0.5). F<sub>1</sub> hybrid embryos were flushed from the genital tract of females ~96 hours post-hCG to recover blastocyst stage embryos. Additionally, females were set up in timed-matings that allow for spontaneous ovulation cycles (untreated controls). B6(CAST7) females were crossed with B6 stud males. As

well, B6 females were mated with *Mus musculus castaneus* (CAST) males (spontaneous ovulation). Embryos were recovered at day 3.5 *postcoitum*; all analyzed embryos were blastocysts, except for B6(CAST7) X B6 E6 (spontaneous ovulation group), E29 (6.25 IU group) and E23 (10 IU group) which were late stage morulae. Embryos were flushed in pre-warmed M2 media (Sigma), washed 3x in 30  $\mu$ L, and individually snap frozen in 1-5  $\mu$ L of M2. Individual embryos were stored at -80°C. For each control and experimental group, embryo collections were performed multiple times, and embryos analyzed were recovered from multiple litters. Experiments were performed in compliance with the guidelines set by the Canadian Council for Animal Care, and the policies and procedures approved by the University of Western Ontario Council on Animal Care.

### **2.2.2 DNA Isolation and Bisulfite Mutagenesis for Individual Embryos**

Bisulfite Mutagenesis with agarose embedding was conducted on single embryos as described (58,59), with modification. Individual embryos were lysed with 0.1% IGEPAL (Biochemika), and 2 mg/mL Proteinase K (Sigma) in 10  $\mu$ L of lysis buffer [100 mM Tris-HCl pH 7.5 (Bioshop), 500 mM LiCl (Sigma), 10 mM EDTA pH 8.0 (Sigma), 1% LiDS (Bioshop), 5 mM DTT (Sigma)] for 1 hour at 50°C. Lysed embryos were embedded in 2% low melting point agarose (Sigma) under mineral oil at 95°C. DNA/agarose beads were allowed to solidify for 10 minutes on ice. Oil was removed and denaturation of DNA was performed in 0.1 M NaOH (Sigma) at 37°C for 15 minutes with shaking. Agarose beads were placed in 2.5 M bisulfite solution [0.125 M hydroquinone (Sigma), 3.8 g sodium hydrogensulfite (Sigma), 5.5 mL water, 1 mL 3 M NaOH] at 50°C

for 3.5 hours to allow bisulfite mutagenesis to occur. Following incubation, agarose beads were washed once in TE pH 7.5, and desulphonated with 0.3 M NaOH at 37°C for 15 minutes with shaking. Agarose beads were washed twice with TE pH 7.5, and twice with water. Beads were incubated under oil at 65°C and ~60 µL of pre-warmed water was added. Agarose beads were mixed by pipetting and 20 µL of diluted agarose was added to one Ready-to-go PCR Bead (GE) containing gene-specific primers and 1 µL of 240 ng/mL tRNA as a carrier. PCRs were split in half allowing two independent PCR reactions to be completed for each gene analyzed. Nested primer sequences and associated information for each gene can be found in Table 2.1. Negative controls (no embryo) were processed alongside each bisulfite reaction.

### **2.2.3 Allele-Specific DNA Methylation Analysis of Individual Embryos for *Snrpn*, *Peg3*, *Kcnq1ot1*, and *H19***

Gene-specific primers used for nested PCR amplification of *Snrpn*, *Peg3*, *Kcnq1ot1* and *H19* as well as melting temperatures for each primer set can be found in Table 2.1. Five µL of first round product was seeded into each second round PCR reaction. Second round products were digested with restriction enzymes that cleave methylated bisulfite converted DNA to ensure no bias in the amplification of methylated/unmethylated products, or with restriction enzymes that cleave species-specific SNPs to ensure no allelic bias was introduced during PCR amplification. PCR amplified products were directly cloned without intervening gel extraction steps, as we observed that column purification drastically decreases the variability of DNA strands recovered (data not



**Table 2.1. Regions and Conditions for PCR Analysis Following Bisulfite Mutagenesis.**

Gene	Accession	Position	Primer Type	Primer Sequence (5'-3')	Annealing Temp	Reference
<i>Snrpn</i>	AF081460	2151	OF	TAT GTA ATA TGA TAT AGT TTA GAA ATT AG	52	24; 25
			OR	AAT AAA CCC AAA TCT AAA ATA TTT TAA TC		
		-2570	IF	AAT TTG TGT GAT GTT TGT AAT TAT TTG G	54	
			IR	ATA AAA TAC ACT TTC ACT ACT AAA ATC C		
<i>Peg3</i>	NT_039413.7	3683033	OF	TTT TGA TAA GGA GGT GTT T	50	This study; 15
			OR	ACT CTA ATA TCC ACT ATA ATA A		
		-3682588	IF	AGT GTG GGT GTA TTA GAT T	53	
			IR	TAA CAA AAC TTC TAC ATC ATC		
<i>Kcnqlot1</i>	AJ271885	141392	OF	GTG TGA TTT TAT TTG GAG AG	52	This study; 26
			OR	CCA CTC ACT ACC TTA ATA CTA ACC AC		
		-141598	IF	GGT TAG AAG TAG AGG TGA TT	52	
			IR	CAA AAC CAC CCC TAC TTC TAT		
<i>H19</i>	U19619	1304	OF	GAG TAT TTA GGA GGT ATA AGA ATT	55	25; 27
			OR	ATC AAA AAC TAA CAT AAA CCT CT		
		-1726	IF	GTA AGG AGA TTA TGT TTA TTT TTG G	50	
			IR	CCT CAT TAA TCC CAT AAC TAT		

OF Outer Forward, OR Outer Reverse, IF Inner Forward, IR Inner Reverse.

shown). One  $\mu\text{L}$  of second round PCR product was used for ligation with the pGEMT-EASY DNA ligation kit (Promega). Ligation was performed overnight at  $4^\circ\text{C}$  and transformed into competent *E. coli* cells (Invitrogen or Zymo Research). Blue/white selection (100 mg/mL IPTG, 50 mg/mL X-gal) was used to select bacterial colonies with ligated products. Individual sequences were obtained by colony PCR of individual bacterial colonies. The pGEMT-EASY vector contains M13 primer sites flanking the multiple cloning site, which were used for amplification of inserted DNA fragments. Approximately 2  $\mu\text{L}$  of PCR product was used for agarose gel electrophoresis to verify amplicon size, and the remainder of the PCR reaction was sent to the Nanuq Sequencing Facility located at McGill University (Montreal, QC) or BioBasic Inc (Markham, ON) for sequencing. As *Kcnq1ot1* was the last gene in each set to be analyzed, a proportion of embryos did not produce a sufficient number of DNA strands to be included in the analysis.

#### **2.2.4 Sequence Analysis**

For each sample and gene analyzed, 40-50 clones were sequenced to obtain a representative number of DNA strands. Chromatograms from each sequence were visualized using FinchTV. Ambiguous base pairs were manually reviewed and assigned a designation (where possible). Each sequence was analyzed for total number and location of CpG associated cytosines, as well as location and number of converted and unconverted non-CpG associated cytosines to obtain conversion rates (number of converted non-CpG cytosines/total number of non-CpG cytosines). Sequences with less

than 85% conversion rates were not included. Identical clones (identical location and number of unconverted CpG associated cytosines, and identical location and number of unconverted non-CpG associated cytosines) were not included. Multiple polymorphisms are present between B6 and CAST sequences at each gene analyzed, allowing parental alleles to be discriminated. Clones possessing both B6 and CAST polymorphisms were determined to be due to crossover during PCR amplification, and were not included. Methylation levels across the region of analysis were determined by calculating the number of methylated CpG / total number of CpG for each individual CpG site as a percentage. Total DNA methylation for each gene was calculated as a percentage of the total number of methylated CpG / the total number of CpG dinucleotides.

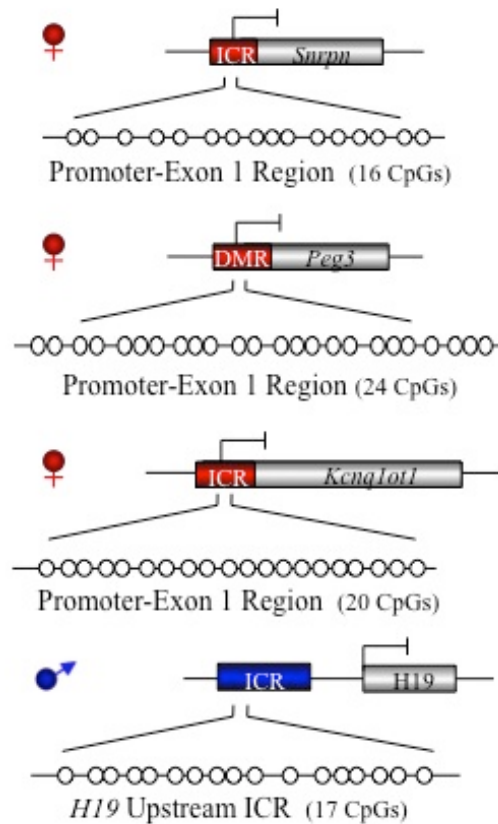
### **2.2.5 Statistical Analysis**

To compute the significance of nonrandom association between groups of embryos, we used the Fisher's exact test. As changes in methylation status were anticipated to be in only one direction (increase or decrease), a one-sided test was utilized. P-values were calculated using software provided online (<http://www.langsrud.com/fisher.htm>), and were considered to be significant at  $p < 0.05$ .

## 2.3 Results

### 2.3.1 Methylation levels of *Snrpn*, *Peg3*, *Kcnq1ot1*, and *H19* in spontaneously ovulated embryos

Prior to examining the effects of superovulation on genomic imprinting, the methylation status of the *Snrpn*, *Kcnq1ot1*, and *H19* ICRs, and the *Peg3* DMR was first determined in individual blastocysts derived from spontaneously ovulating females. The regions analyzed included 16 CpGs located in the *Snrpn* ICR (Lucifero et al., 2004; Mann et al., 2004), 24 CpGs located in the *Peg3* DMR (Lucifero et al., 2004), 20 CpGs located in the *Kcnq1ot1* ICR (26), and 17 CpGs located in the *H19* ICR (25,27) (Figure 2.1). Methylation analyses using bisulfite mutagenesis and sequencing were performed on B6(CAST7) X B6 F<sub>1</sub> individual blastocysts. Ten individual embryos were analyzed at the four loci. The *Kcnq1ot1* and *Snrpn* ICRs, and the *Peg3* DMR acquire maternal-specific methylation during oogenesis, while the *H19* ICR acquires paternal-specific methylation during spermatogenesis; oocytes are unmethylated at the *H19* ICR in mice (Davis et al., 2000; Lucifero et al., 2004). Similar DNA methylation patterns are observed for the human *SNRPN* and *H19* genes (Geuns et al., 2003; Borghol et al., 2006). Therefore, in B6(CAST7) X B6 blastocyst stage embryos, the maternal (CAST) alleles of *Kcnq1ot1*, *Snrpn*, and *Peg3* should be methylated, while the paternal (B6) allele of *H19* should be methylated. As anticipated from previous reports of pools of blastocysts (Tremblay et al., 1995; Tremblay et al., 1997; Mann et al., 2003; Mann et al., 2004; Reese et al., 2007), the maternal DNA strands of *Snrpn*, *Peg3*, and *Kcnq1ot1* were hypermethylated (Supplementary Figure 2.1-2.3), while the maternal *H19* DNA strands were



**Figure 2.1. Schematic Diagram of Regions Analyzed by Bisulfite Mutagenesis and Sequencing Assay.**

Maternal methylated *Snrpn*, *Peg3*, and *Kcnq1ot1* alleles, and the paternal methylated *H19* allele are indicated. ICR, Imprinted Control Region. DMR, Differentially Methylated Region. Open circles, CpGs. Blunt arrow designates transcription start site of non-transcribed allele. Regions analyzed are as follows: *Snrpn* ICR, 16 CpGs (15 CpGs in CAST) located in the promoter and first exon of the *Snrpn* gene; *Peg3* DMR, 24 CpGs (23 CpGs in B6) located in the promoter and first exon of the *Peg3* gene; *Kcnq1ot1* ICR, 20 CpGs located in the *Kcnq1ot1* ICR; and *H19* ICR, 17 CpGs (16 CpGs in B6) in the ICR located 2-4 kb upstream of the transcriptional start site of *H19*.

hypomethylated (Supplementary Figure 2.4). Only maternal strands are shown as superovulation is thought to affect genomic imprinting during oocyte development, hence only affecting the maternal allele (Supplementary Figures 2.1-2.4). From the analysis of embryos derived from spontaneously ovulated females, baseline total CpG methylation levels were determined to be greater than 65%, 70% and 85% for *Snrpn*, *Peg3* and *Kcnq1ot1*, respectively, and less than 25% for *H19*.

The reciprocal B6 X CAST cross was also performed to ensure that B6(CAST7) X B6 F<sub>1</sub> embryos from spontaneously ovulated females were representative of normal imprinted methylation. Maternal *Snrpn* strands displayed baseline total CpG methylation levels of 65% (Supplementary Figure 2.5). Levels of baseline total CpG methylation on maternal *Peg3* and *Kcnq1ot1* DNA strands in B6 X CAST F<sub>1</sub> embryos were 75% and 75%, respectively (Supplementary Figures 2.6, 2.7). The maternal *H19* DNA strands were hypomethylated (Supplementary Figure 2.8), with less than 15% total CpG methylation. As no statistical difference was observed between embryos displaying aberrant methylation from the two crosses as determined by the Fisher's Exact test, these two spontaneously ovulating groups were combined for statistical calculations. We conservatively set the baseline total CpG methylation level to greater than 65%, 70%, and 75% for *Snrpn*, *Peg3*, and *Kcnq1ot1*, respectively, and less than 25% for *H19*. These values were used to determine loss or gain of methylation in embryos from superovulated females.

Interestingly, for all imprinted genes investigated, at least one embryo displayed a drastic loss of methylation at the normally methylated maternal allele. For the

B6(CAST7) X B6 F<sub>1</sub> embryos, one embryo displayed loss of methylation at the normally methylated maternal allele for *Snrpn* (E5, 60% methylation), *Peg3* (E114, 55%), and *Kcnq1ot1* (E112, 23%) (Supplementary Figures 2.1-2.3). For B6 X CAST F<sub>1</sub> embryos, spontaneous loss of methylation was observed at one embryo at the *Snrpn* ICR (E80, 50% methylation), the *Peg3* DMR (E79, 34%), and at the *Kcnq1ot1* ICR (E74, 58%) (Supplementary Figure 2.5-2.7). None of the F<sub>1</sub> embryos displayed spontaneous gain of methylation at the *H19* ICR. One embryo (E83) was observed to have reversed *Kcnq1ot1* methylation; the maternal B6 strand had acquired a paternal imprinted methylation pattern, while the paternal CAST strand had acquired a maternal imprinted pattern (Supplementary Figure 2.7). This is a rare event that has been observed previously for *H19* imprinted expression (Mann et al., 2004).

### **2.3.2 Superovulation results in loss of maternal *Snrpn*, *Peg3*, and *Kcnq1ot1* methylation in a dose-dependent manner**

To determine the effects of superovulation on imprinted methylation, we examined embryos derived following both low and high dosages of hormonal stimulation. Hormone dosages typically employed for superovulation in the mouse range from 2.5 to 10 IU, with 5 IU being the recommended dose for most mouse strains (Nagy et al, 2003). We chose 6.25 IU to represent to the low hormone dose, as lower concentrations were not as ineffective at inducing superovulation in the B6(CAST7) mice, and 10 IU for the high hormone dose (Nagy et al, 2003). *Snrpn*, *Peg3* and *Kcnq1ot1* are normally paternally expressed and maternally methylated. Data were obtained from 10 embryos each in the

6.25 and 10 IU hormone treatment groups for *Snrpn*, and from 9 embryos in each hormone treatment group for *Peg3*, while 5 embryos from the 6.25 IU group, and 9 embryos from the 10 IU group were analyzed for *Kcnqlot1* imprinted methylation. Forty-50 clones were sequenced and analyzed for each gene. Methylation levels were analyzed at individual CpG dinucleotide across each ICR/DMR, as well as for the total number of methylated CpGs for each gene per embryo.

*Snrpn* displayed a loss of maternal methylation at both hormone dosages (Supplementary Figure 2.9), with the loss more frequent at the high hormone dosage (Figure 2.2 and 2.3). Analysis of total CpG methylation revealed that *Snrpn* exhibited a loss of methylation at the low hormone dosage on the maternal allele for four embryos (E29 31%, E13 63%, E13 45%, and E33 54% total CpG methylation of DNA strands) (Figure 2.2), and a loss of methylation at the high hormone dosage on the maternal allele for nine embryos (E10 57%, E8 55%, E1 42%, E4 63%, E23 53%, E5 59%, E6 49%, E13 63%, and E11 61% total CpG methylation) (Figure 2.3), when compared to embryos from spontaneously ovulated females (baseline of 65% methylation). This loss of methylation at the high dosage was significantly different from control embryos ( $p = 0.001$ ) as calculated by the Fisher's exact test.

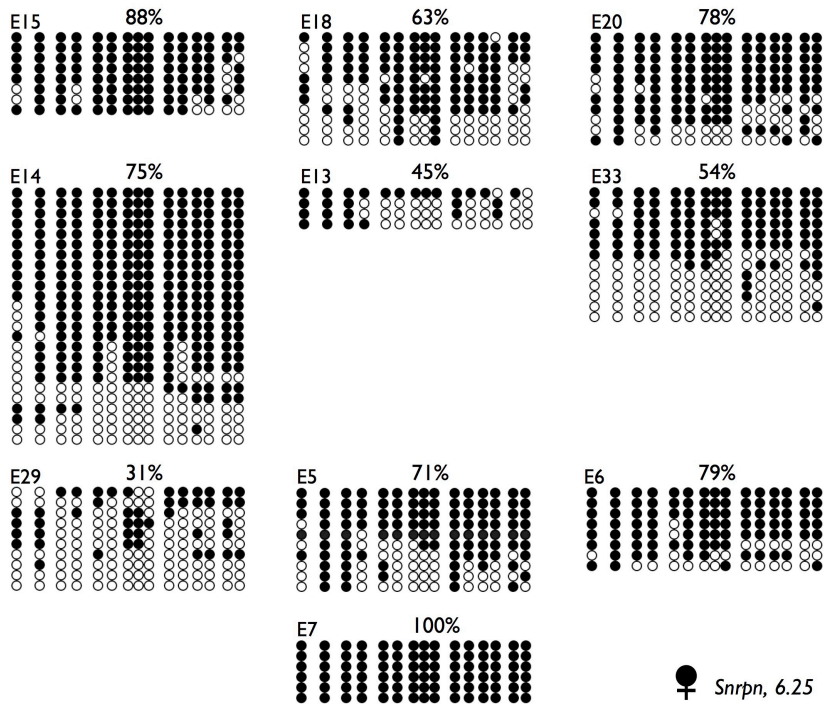
A similar pattern of loss of methylation was observed for *Peg3* when compared to *Snrpn*; both hormone dosages displayed a loss of methylation on maternal DNA strands (Supplementary Figure 2.10), with a greater frequency of loss in the high hormone dosage group (Figure 2.4 and 2.5). *Peg3* displayed a loss of maternal methylation for four embryos (E14 67%, E29 49%, E18 67%, and E33 66% total CpG methylation) at the low

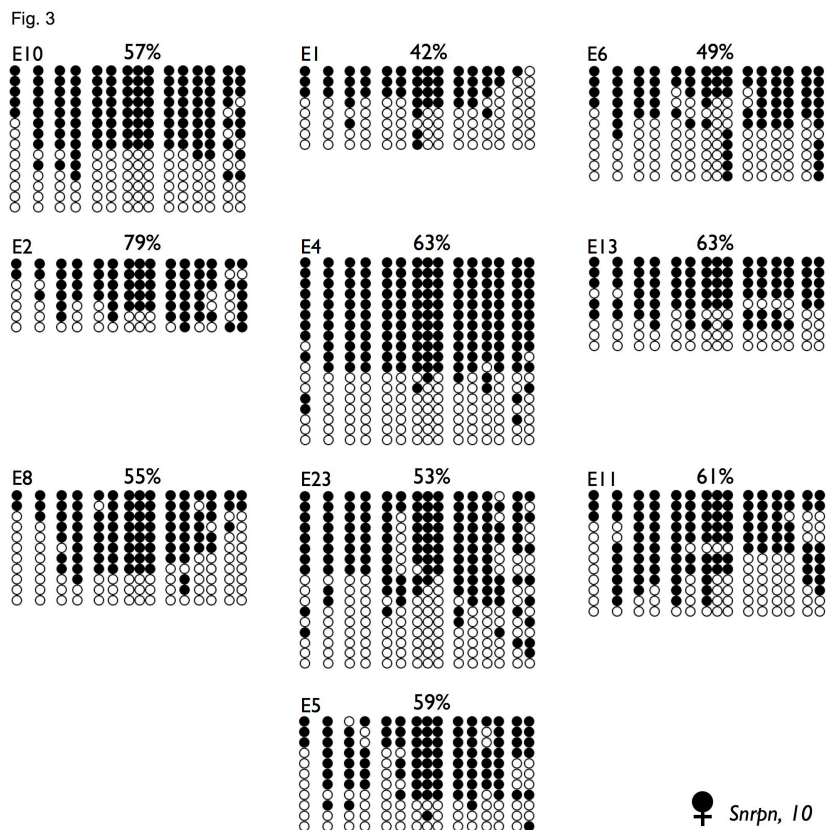


**Figure 2.2. Methylation of the Maternal *Snrpn* ICR in B6(CAST7) X B6 F<sub>1</sub> Embryos Derived from Low Dosage Superovulated Females.**

Methylation status of individual DNA strands in the *Snrpn* ICR (maternal, CAST strands shown) in blastocysts derived from females superovulated with a 6.25 IU hormone dosage. Unmethylated CpGs are represented as empty circles while methylated CpGs are depicted as filled circles. Each line denotes an individual strand of DNA. Clones with identical methylation patterns and non-CpG conversion rates representing the same DNA strand were included once. Each group of DNA strands represents data from a single embryo, with the embryo designation indicated at the top left. Percent methylation is indicated above each set of DNA strands, and was calculated as the number of methylated CpGs / total number of CpG dinucleotides. The region analyzed contains 15 CpGs; a base pair change in the maternal CAST allele eliminates CpG dinucleotide 1.

Fig. 2

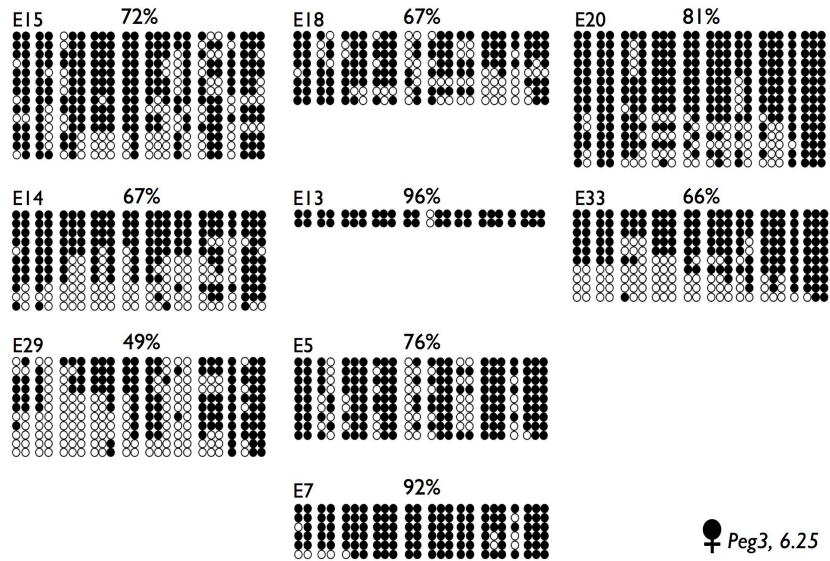




**Figure 2.3: Methylation of the Maternal *Snrpn* ICR in B6(CAST7) X B6 F<sub>1</sub> Embryos Derived from High Dosage Superovulated Females.**

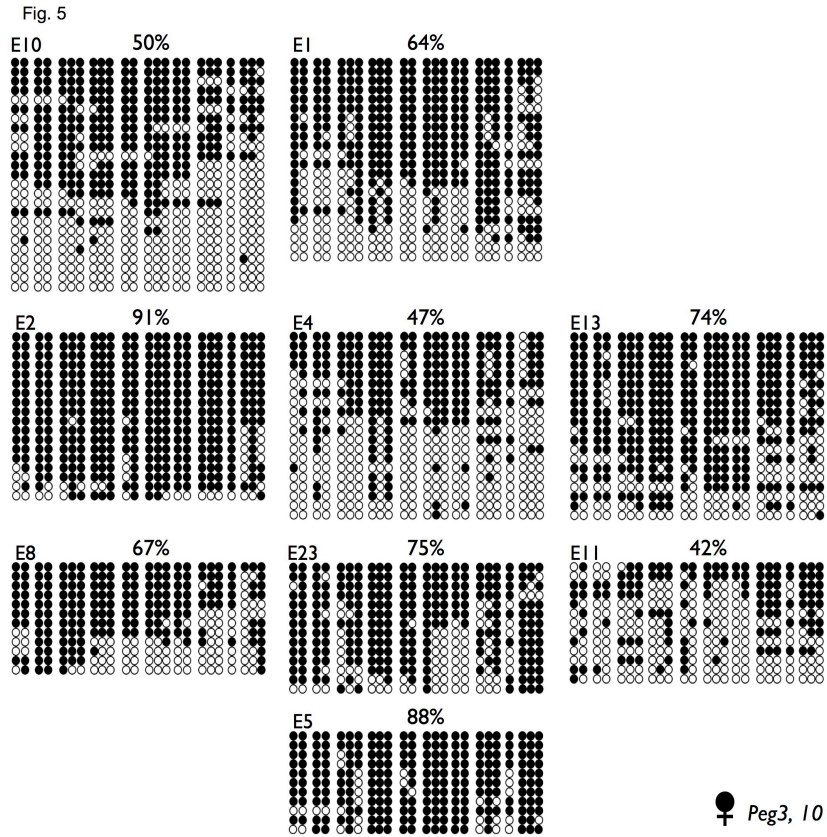
Methylation status of individual DNA strands in the *Snrpn* ICR (maternal, CAST strands shown) in blastocysts derived from females superovulated with a 10 IU hormone dosage. The region analyzed contains 15 CpGs; a base pair change in the maternal CAST allele eliminates CpG dinucleotide 1. Details are as described in Figure 2.2.

Fig. 4



**Figure 2.4. Methylation of the Maternal *Peg3* DMR in B6(CAST7) X B6 F<sub>1</sub> Embryos Derived from Low Dosage Superovulated Females.**

Methylation status of individual DNA strands in the *Peg3* DMR (maternal, CAST strands shown) in blastocysts derived from females superovulated with a 6.25 IU hormone dosage. The region analyzed contains 24 CpGs. Details are as described in Figure 2.2.



**Figure 2.5. Methylation of the Maternal *Peg3* DMR in B6(CAST7) X B6 F<sub>1</sub> Embryos Derived from High Dosage Superovulated Females.**

Methylation status of individual DNA strands in the *Peg3* DMR (maternal, CAST strands shown) in blastocysts derived from females superovulated with a 10 IU hormone dosage.

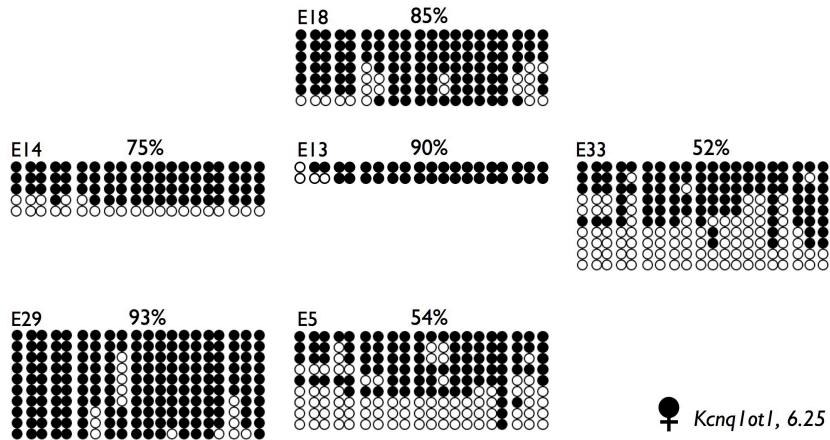
The region analyzed contains 24 CpGs. Details are as described in Figure 2.2.

hormone dosage (Figure 2.4), and a loss of methylation for five embryos (E10 50%, E8 67%, E1 64%, E4 47%, and E11 42% CpG methylation) at the high hormone dosage (Figure 2.5), when compared to embryos from spontaneously ovulated females (baseline of 70% total CpG methylation). This loss of imprinted methylation was statistically significant in the higher hormone treatment group when compared to the spontaneous ovulation group ( $p = 0.03$ ).

*Kcnq1ot1*, a third paternally expressed gene, also exhibited a similar loss of methylation on maternal DNA strands at both hormone dosages (Supplementary Figure 2.11), with a greater frequency of loss in the high hormone dosage group (Figure 2.6 and 2.7). *Kcnq1ot1* exhibited a loss of maternal methylation for two embryos (E5 54%, and E33 52% CpG methylation) at the low hormone dosage (Figure 2.6), and five embryos (E2 64%, E8 56%, E4 43%, E5 62%, and E13 53% total CpG methylation) at the high hormone dosage (Figure 2.7), when compared to embryos from spontaneously ovulated females (baseline of 75% CpG methylation). Loss of *Kcnq1ot1* imprinted methylation was not statistically significant for either hormone treatment group when compared to controls ( $p = 0.4$  for the 6.25 IU treatment group and  $p = 0.08$  for the high hormone dosage), although the high hormone dosage group approached statistical significance. Analysis of additional embryos may be required to achieve significance.

### **2.3.3 Superovulation results in gain of maternal *H19* methylation in a dose-dependent manner**

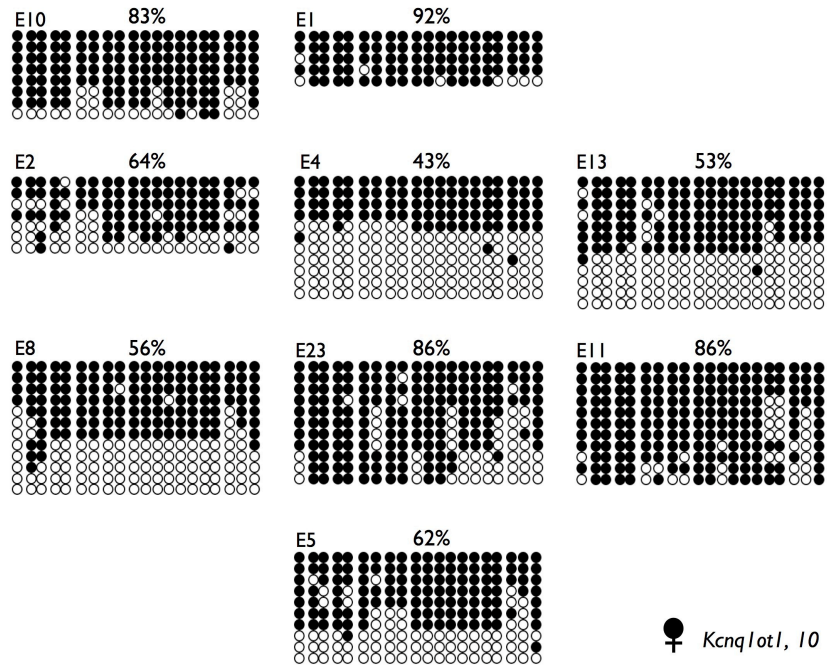
Fig. 6



**Figure 2.6. Methylation of the Maternal *Kcnq1ot1* ICR in B6(CAST7) X B6 F<sub>1</sub> Embryos Derived from Low Dosage Superovulated Females.**

Methylation status of individual DNA strands in the *Kcnq1ot1* ICR (maternal, CAST strands shown) in blastocysts derived from females superovulated with a 6.25 IU hormone dosage. Details are as described in Figure 2.2.

Fig. 7



**Figure 2.7. Methylation of the Maternal *Kcnqlot1* ICR in B6(CAST7) X B6 F<sub>1</sub>**

**Embryos Derived from High Dosage Superovulated Females.**

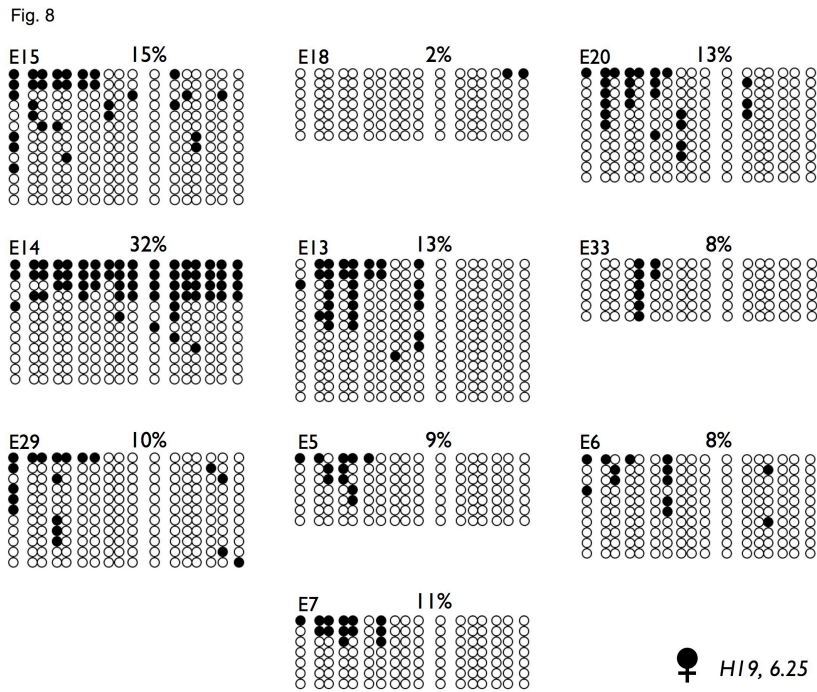
Methylation status of individual DNA strands in the *Kcnqlot1* ICR (maternal, CAST strands shown) in blastocysts derived from females superovulated with a 10 IU hormone dosage. Details are as described in Figure 2.2.



The same ten embryos analyzed for imprinted methylation of the *Snrpn*, *Peg3* and *Kcnq1ot1* ICR/DMRs were also used for analysis of the *H19* ICR. *H19* displayed a gain of maternal methylation at both hormone dosages, particularly for CpG dinucleotides 8-17 (Supplementary Figure 2.12), with the loss more frequent at the high hormone dosage (Figure 2.8 and 2.9). At the low hormone dose, one of ten embryos displayed a gain of maternal methylation, as seen by the presence of greater than 25% baseline CpG methylation of DNA strands (E14 32% methylation) (Figure 2.8). At the higher hormone dosage (10 IU), 4 of 10 embryos displayed a gain of maternal methylation (E8 66%, E4 43%, E13 67%, and E11 53% CpG methylation) (Figure 2.9). This gain of methylation at the higher dosage was significantly different from control embryos ( $p = 0.003$ ). These embryos acquired a more paternal-like pattern of methylation at the *H19* ICR.

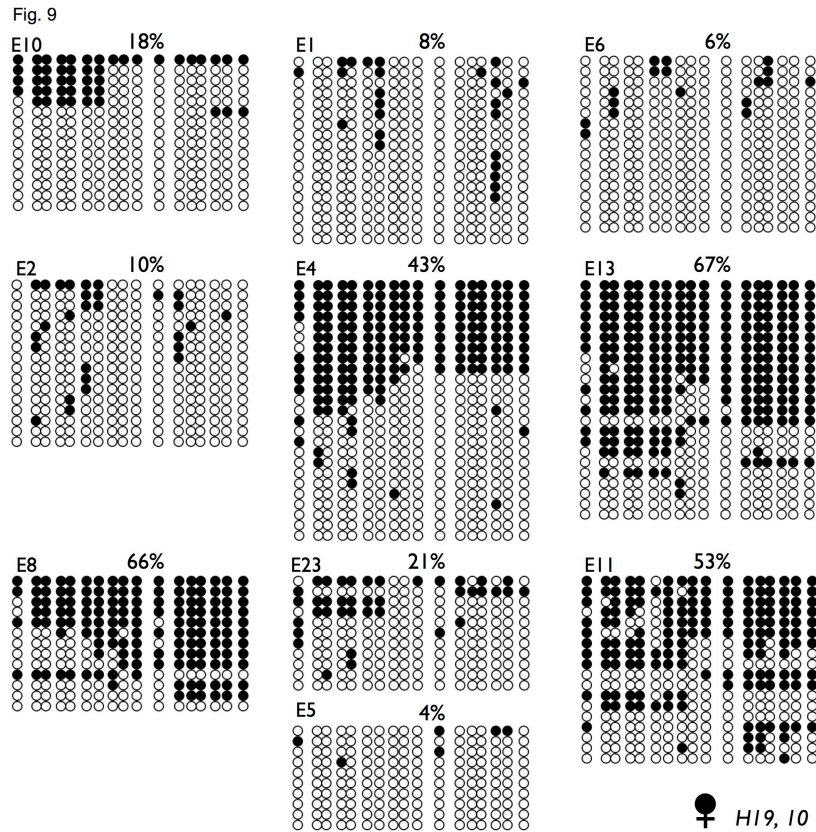
#### **2.3.4 Superovulation results in loss of paternal *H19* methylation in a dose-dependent manner**

Studies of the effects of superovulation on genomic imprinting focused on the maternal allele, as superovulation is thought to affect genomic imprinting during oocyte development. Using our protocol, methylation data was obtained for both maternal and paternal of the four imprinted genes from individual preimplantation embryos. Surprisingly, not only did we observe significant effects of superovulation on imprinted methylation of maternal alleles as described above, we also observed a loss of methylation on the normally methylated paternal *H19* allele at both hormone dosages, especially for CpG dinucleotides 1-7 (Supplementary Figure 2.13), with more frequent



**Figure 2.8. Methylation of the Maternal *H19* ICR in B6(CAST7) X B6 F<sub>1</sub> Embryos Derived from Low Dosage Superovulated Females.**

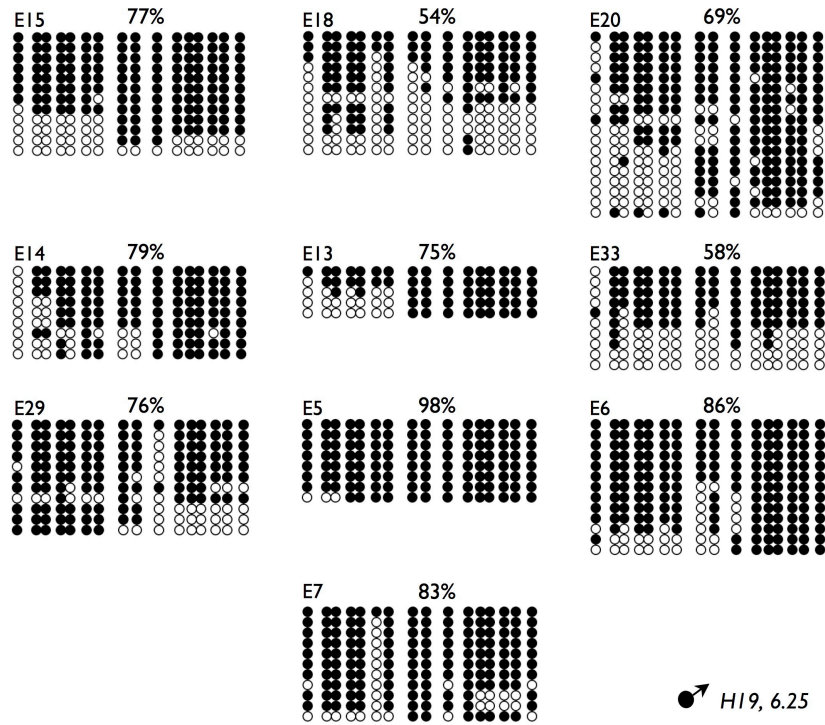
Methylation status of individual DNA strands in the *H19* upstream ICR (maternal, CAST strands shown) in blastocysts derived from females superovulated with a 6.25 IU hormone dosage. The region of the maternal CAST *H19* allele analyzed contains 17 CpGs. Details are as described in Figure 2.2.



**Figure 2.9. Methylation of the Maternal *H19* ICR in B6(CAST7) X B6 F<sub>1</sub> Embryos Derived from High Dosage Superovulated Females.**

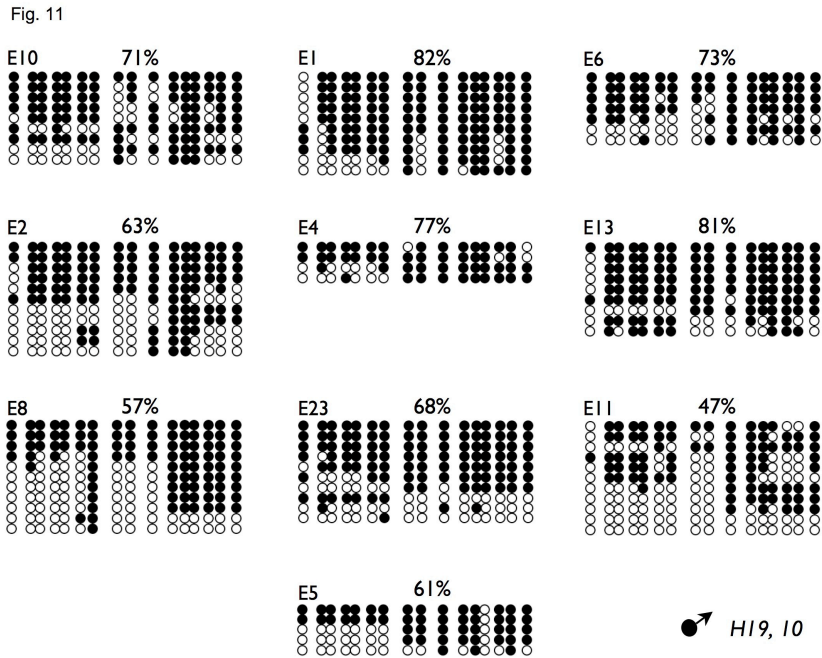
Methylation status of individual DNA strands in the *H19* upstream ICR (maternal, CAST strands shown) in blastocysts derived from females superovulated with a 10 IU hormone dosage. The region of the maternal CAST *H19* allele analyzed contains 17 CpGs. Details are as described in Figure 2.2.

Fig. 10



**Figure 2.10. Methylation of the Paternal *H19* ICR in B6(CAST7) X B6 F<sub>1</sub> Embryos Derived from Low Dosage Superovulated Females.**

Methylation status of individual DNA strands in the *H19* upstream ICR (paternal, B6 strands shown) in blastocysts derived from females superovulated with a 6.25 IU hormone dosage. The region of the paternal B6 *H19* allele analyzed contains 16 CpGs due to a polymorphism that eliminates CpG8. Details are as described in Figure 2.2.



**Figure 2.11. Methylation of the Paternal *H19* ICR in B6(CAST7) X B6 F<sub>1</sub> Embryos Derived from High Dosage Superovulated Females.**

Methylation status of individual DNA strands in the *H19* upstream ICR (paternal, B6 strands shown) in blastocysts derived from females superovulated with a 10 IU hormone dosage. The region of the paternal B6 *H19* allele analyzed contains 16 CpGs due to a polymorphism that eliminates CpG8. Details are as described in Figure 2.2.

loss of methylation at the high hormone dosage (Figure 2.10 and 2.11). For both B6(CAST7) X B6 (Supplementary Figure 2.14), and B6 X CAST F<sub>1</sub> embryos (Supplementary Figure 2.15) from spontaneously ovulated females, *H19* displayed 79% and 77% total CpG methylation on paternal DNA strands. Thus, the baseline level of total CpG methylation on the paternal *H19* allele was set at 75%. Of the above embryos derived from spontaneously ovulating females, two B6(CAST7) X B6 F<sub>1</sub> embryo and two B6 X CAST F<sub>1</sub> embryo displayed loss of CpG methylation on paternal DNA strands (E10 71%, E113 50%, and E73 61%, E74 56% methylation). By comparison, embryos from induced ovulations exhibited a loss of paternal *H19* methylation. At the low hormone dosage, three embryos (E18 54%, E20 69%, and E33 58% methylation) displayed a loss of methylation on paternal DNA strands (Figure 2.10), while at the high hormone dosage, seven embryos (E10 71%, E2 63%, E8 57%, E23 68%, E5 61%, E6 73%, and E11 47% CpG methylation) showed a loss of paternal methylation (Figure 2.11). This loss of imprinted methylation on the paternal *H19* strand was statistically significant in the high hormone treatment group ( $p = 0.02$ ).

For the other imprinted genes analyzed, low levels of total CpG methylation were present on the paternal alleles *Snrpn*, *Peg3* and *Kcnqlot1* following spontaneous and induced ovulation (Supplementary Figures 2.16-2.27). After taking baseline levels of total CpG methylation, one embryo from each dosage group showed a gain of paternal-specific *Snrpn* methylation (6.25 IU treatment E14 35%; and 10 IU treatment group E8 36%), one embryo from each hormone treatment group displayed a gain of paternal-specific *Peg3* methylation (6.25 IU treatment E31 51%; and 10 IU treatment groups E11

36%), and one embryo had a gain in paternal-specific *Kcnq1ot1* methylation in the 6.25 IU treatment (E33 23%). In contrast to paternal *H19* methylation, these results were not statistically significant, and no effect of dosage was observed.

### **2.3.5 Perturbation of Imprinted Methylation for Multiple Genes**

To determine the incidence of aberrant methylation (gain or loss) in the various treatment groups, the number of embryos with perturbation in methylation of the maternal *Snrpn*, *Peg3*, *Kcnq1ot1* and *H19* ICR/DMRs, and the paternal *H19* ICR were assessed by the Fisher's exact test (Table 2.2). At the low hormone dosage, 4 of 10 embryos (E14, E29, F18, and E33) showed aberrant methylation of 2 or more genes, which was significantly different than embryos derived from spontaneously ovulated females where only a single embryo (E74) displayed aberrant methylation of more than one gene ( $p = 0.05$ ). At the high dose, 10 of 10 embryos displayed aberrant methylation for 2 or more genes. When compared to control embryos, this difference was highly significant ( $p = 0.00002$ ). When all four genes were examined, no embryos exhibited aberrant methylation patterns at all loci at the low hormone concentration. However at the high hormone dosage, one embryo (E8) displayed perturbed methylation at the maternal allele of all four genes, as well as at the paternal *H19* allele. These data clearly demonstrate the dose-dependent effect of superovulation on perturbation of imprinted methylation.

**Table 2.2. Comparison of Hormone Dosage and Aberrant Imprinted Methylation**

Dosage Genotype	Embryo	<i>Snrpn</i> Mat Loss (>65%)	<i>Peg3</i> Mat Loss (>70%)	<i>Kcnq1ot1</i> Mat Loss (>75%)	<i>H19</i> Mat Gain (<25%)	<i>H19</i> Pat Loss (>75%)
<b>0 IU CAST7XB6</b>	E2			ND		
	E5	60		ND		
	E10					71
	E112			23		
	E114		55			
	E113				ND	63
	E115					
	E400				ND	
	E414				ND	
	E6					
<b>0 IU B6XCAST</b>	E73					61
	E74			58		56
	E79		34			
	E80	60				
	E83			R		
	E84					
	E85					
<b>6.25 IU CAST7XB6</b>	E15			ND		
	E14		67		32	
	E29	31	49			
	E18	63	67			54
	E13	45				
	E5			54		
	E7				ND	
	E20				ND	69
	E33	54	66	52		58
E6			ND	ND		
<b>10 IU CAST7XB6</b>	E10	57	50			71
	E2			64		63
	E8	55	67	56	66	57
	E1	42	64			
	E4	63	47	43	43	
	E23	53				68
	E5	59		62		61
	E6	49	ND	ND		73
	E13	63		53	67	
	E11	61	42		53	47

ND Not determined; R reversal of imprinted DNA methylation.



## **2.4 Discussion**

In this study, we utilized a mouse model system to investigate the effects of superovulation on genomic imprinting in blastocyst stage embryos. Blastocysts were examined for parental-specific methylation changes to circumvent the chance of cumulus cell contamination that otherwise could be an issue when analyzing oocytes and early cleavage stage embryos. Furthermore, by studying embryos instead of oocytes, we minimized the effects of *in vitro* manipulations, as well as limited our analysis to those oocytes that were capable of being fertilized and producing embryos. We have demonstrated that superovulation perturbed genomic imprinting of both maternally and paternally expressed genes, and that this perturbation was dose-dependent. Previously, superovulation had been postulated to function by affecting oocyte development, and therefore effects were expected to be restricted to the maternal allele. In our study, we have demonstrated that maternal-specific methylation imprints as well as paternal-specific methylation imprints were disrupted by superovulation. Furthermore, we observed that superovulation results in perturbation of genomic imprinting for multiple genes within the same embryo.

### **2.4.1 Superovulation Perturbs Genomic Imprinting**

Assisted reproduction has been linked to the generation of epigenetic errors that result in the development of the human imprinting disorders Angelman Syndrome and Beckwith-Wiedemann Syndrome (Cox et al., 2002; DeBaun et al., 2003; Gicquel et al.,

2003; Maher et al., 2003; Orstavik et al., 2003; Halliday et al., 2004). Commonality between ART-associated BWS and AS is loss of maternal-specific methylation at the imprinting control regions at 11p15 and 15q11-13, respectively (Cox et al., 2002; DeBaun et al., 2003; Gicquel et al., 2003; Maher et al., 2003; Orstavik et al., 2003).

Multiple studies have examined the association of ARTs and imprinting, and in all cases examined some type of ovarian stimulation regime was consistently employed to facilitate conception (Young et al., 1998; Van der Auwera and D'Hooghe, 2001; Gicquel et al., 2003; Chang et al., 2005; Ludwig et al., 2005). Significantly, in both Angelman and Beckwith-Wiedemann Syndrome studies, patients were identified where the only ART procedure used was ovarian stimulation.

In the current study, we assessed the effects of superovulation on the ICRs of *Snrpn*, *Kcnq1ot1* and *H19* genes that have a causal role in the etiology of BWS and AS. Following superovulation, we observed a loss of maternal methylation in blastocyst stage embryos at the ICRs of the paternally expressed *Snrpn* and *Kcnq1ot1* genes in individual mouse preimplantation embryos. While the effects of superovulation have not previously been examined at the blastocyst stage for *Snrpn*, no effect on *Snrpn* imprinted methylation was observed following superovulation in midgestation mouse embryo and placentas (Fortier et al., 2008). The effects of superovulation on *Kcnq1ot1* have not been previously examined at the blastocyst stage, however a decrease in hypermethylated *Kcnq1ot1* alleles from stimulated human oocytes compared to unstimulated controls has been observed (Khoueiry et al., 2008). Together these observations show that superovulation is associated with loss of DNA methylation at imprinted loci known to be

linked to the development of AS and BWS. This study further provides a mechanistic link between ARTs and imprinting disorders.

The effect of superovulation on maternal methylation of the *Peg3* DMR has not been previously evaluated at any stage of development. Similar to the other paternally expressed genes examined, we observed a loss of maternal *Peg3* methylation following superovulation. Our results constitute a novel finding, and suggest that the effects of ARTs may not be limited to a subset of imprinted genes but may affect multiple imprinted loci. *Peg3* is a zinc finger protein thought to interact with *p53* and *Bax* to regulate neuronal apoptosis in response to hypoxia or DNA damage (Deng and Wu, 2000; Relaix et al., 2000; Johnson et al., 2002). Loss of *Peg3* expression is associated with aberrant maternal nurturing behaviour and an offspring's ability to thrive (Li et al., 1999; Murphy et al., 2001; Curley et al., 2004), phenotypes that have been linked to increased neuronal apoptosis during neonatal brain development (Broad et al., 2009). Furthermore, loss of methylation at the *Peg3* DMR has been linked to spontaneous abortion (Liu et al., 2008). Our data is of interest, in light of the fact that children born through ART are at an increased risk of neonatal mortality and intensive care unit admission (Basatemur and Sutcliffe, 2008) and increased risk of low birth weight and premature delivery (Sunderam et al., 2009). Our observation that superovulation results in a loss of imprinted methylation at the *Peg3* DMR may suggest an additional mechanism contributing to the risks of ART.

In addition to loss of maternal methylation, we observed a gain of maternal methylation for the normally unmethylated maternally *H19* allele in blastocyst stage

embryos. This is consistent with the report by Sato et al. (Sato et al., 2007), who observed a gain of maternal *H19* methylation following superovulation in mouse and human oocytes, and by Borghol et al. (Borghol et al., 2006) who observed methylated *H19* alleles in oocytes obtained from women undergoing ovarian stimulation followed by *in vitro* maturation. In contrast, our data differ from those reported by Fortier et al. (Fortier et al., 2008), who observed that *H19* methylation in midgestation mouse embryos and placentas derived from superovulated mothers did not reveal a gain of maternal *H19* methylation. This discrepancy may be explained by smaller sample size, single low hormone dosage, or technical difficulties with the bisulfite protocol discussed by the authors (Fortier et al., 2008). Another report cited no difference in *H19* methylation following superovulation in individual blastocysts, however, methylation analyses were not done allelically; therefore, methylated maternal alleles would not have been discriminated from appropriately methylated paternal alleles (Fauque et al., 2007).

#### **2.4.2 Superovulation Perturbs Genomic Imprinting for Multiple Genes in the Same Embryo**

Analysis of the incidence of imprinted methylation defects following superovulation revealed that many embryos harboured aberrant methylation for 2 or more genes, which was significantly different from embryos from spontaneously ovulated females where only a single embryo displayed aberrant methylation for more than one gene. Similar observations were recently reported in ART-conceived children with BWS (Lim et al., 2009); imprinting defects at multiple imprinted loci other than the *Kcnq1ot1* ICR were

more frequently observed in BWS patients whose parents had undergone some form of ART than in non-ART BWS patients. These data suggest that developmental defects or abnormal growth in ART children might be caused by variable combinations of epigenetic perturbations at imprinted genes, perhaps offering an explanation for a postulated new syndrome characterized by overgrowth and severe developmental delay (Shah et al., 2006). Developmental and growth abnormalities could also plausibly result from combinations of ART-induced epigenetic perturbations at imprinted and non-imprinted genes, indicative of broad effects of ART on DNA methylation (Katari et al., 2009).

#### **2.4.3 Superovulation may lead to perturbation in imprint acquisition as well as imprint maintenance**

Loss of imprinted methylation in embryos derived from superovulated mothers, but not in control females, indicates that superovulation disrupts mechanisms that establish imprinting during oogenesis. There are a number of possible explanations for the loss of imprinting following superovulation. Hormonal stimulation may result in the “rescue” of subordinate follicles which may have entered the follicular atresia pathway and that otherwise would not have been ovulated resulting in ovulation of lower quality oocytes (Van der Auwera and D'Hooghe, 2001), it may lead to rapid oocyte maturation that perturbs genomic imprints, or it may induce ovulation of immature oocytes that have not completely acquired their imprints (Paoloni-Giacobino and Chaillet, 2004; Ludwig et al., 2005). In humans, ovarian stimulation has been shown to accelerate the growth rate of ovarian follicles when compared to non-stimulated controls (Baerwald et al., 2009). In

the case of genomic imprinting, this shortened maturation time may lead to improper or incomplete acquisition of imprinting marks on the maternal alleles. However, no change in the activity or localization of DNMT1 has been noted in embryos following superovulation (Doherty et al., 2000). Further investigations are required to distinguish between these possibilities.

As the use of exogenous hormones occurs during oogenesis, effects of superovulation were expected to be restricted to the maternal allele. Surprisingly, we report that *H19* displayed a loss of methylation on the paternal, sperm-contributed allele, indicating that events that occur during oocyte maturation regulate imprinting on both the maternal and paternal alleles. At this point, it is not known whether this effect extends to other ICR that are unmethylated on the maternal allele, or if it is limited to the *H19* ICR. However, our data support a recent study that observed activated expression of the normally silent, paternal *H19* allele following superovulation (Fortier et al., 2008), as well as, a second study that showed aberrant *H19* imprinted methylation in F<sub>1</sub> and F<sub>2</sub> male offspring of superovulated female mice (Stouder et al., 2009). Thus, we postulate that superovulation has dual effects during oogenesis, acting to disrupt the acquisition of imprints in the growing oocyte, as well as causing molecular changes that disrupt maternal-effect gene products subsequently required for genomic imprint maintenance during preimplantation development.

#### **2.4.4 Dose-Dependent Effects of Superovulation**

Dose-dependent effects of ovarian stimulation on genomic imprinting have not been previously reported. To evaluate this, we performed experiments using two different dosages of hormones, 6.25 IU (low) and 10 IU (high). All four imprinted genes investigated displayed a dose-dependent response to superovulation. A greater number of embryos displayed perturbed imprinted methylation on the maternal alleles of *Snrpn*, *Peg3*, and *Kcnq1ot1*, and on both the maternal and paternal allele of *H19*, at the high hormone dosage compared to the low hormone dosage. Various hormone types and regimens are currently used for the treatment of subfertility. A mild stimulation regimen was shown to decrease the incidence of aneuploidy in resulting embryos when compared to the standard higher dose regimen (Baart et al., 2007), and high dosages of exogenous gonadotropins are associated with lower pregnancy rates (Stadtmauer et al., 1994). Our study suggests that increasing hormone dosages in an effort to increase the number of oocytes recovered may have detrimental effects on embryo development. These observations are particularly important in light of the movement in the field towards single embryo transfers, where a natural cycling regime would not be detrimental to pregnancy outcome.

A significant finding from these studies is that superovulation results in dysregulation of genomic imprinting in the absence of other confounding factors. This is relevant at the clinical and community-wide level, as ovarian stimulation is currently an indispensable component of the ART protocol to treat human subfertility / infertility. As the genes investigated in this study play an important role in early development, and genetic and epigenetic perturbations lead to imprinting disorders, we propose that

superovulation may increase the risk of developing these disorders in the ART population. Our studies and others like it argue for a more conservative use of assisted reproductive technologies, as well as more in-depth investigations of the effects of these technologies on human populations.



## 2.5 References

- Baart, E. B., Martini, E., Eijkemans, M. J., Van Opstal, D., Beckers, N. G., Verhoeff, A., Macklon, N. S. and Fauser, B. C. (2007) 'Milder ovarian stimulation for in-vitro fertilization reduces aneuploidy in the human preimplantation embryo: a randomized controlled trial', *Hum Reprod* 22(4): 980-8.
- Baerwald, A. R., Walker, R. A. and Pierson, R. A. (2009) 'Growth rates of ovarian follicles during natural menstrual cycles, oral contraception cycles, and ovarian stimulation cycles', *Fertil Steril* 91(2): 440-9.
- Basatemur, E. and Sutcliffe, A. (2008) 'Follow-up of children born after ART', *Placenta* 29 Suppl B: 135-40.
- Berger, S. L. (2007) 'The complex language of chromatin regulation during transcription', *Nature* 447(7143): 407-12.
- Borghol, N., Lornage, J., Blachere, T., Sophie Garret, A. and Lefevre, A. (2006) 'Epigenetic status of the H19 locus in human oocytes following in vitro maturation', *Genomics* 87(3): 417-26.
- Bowdin, S., Allen, C., Kirby, G., Brueton, L., Afnan, M., Barratt, C., Kirkman-Brown, J., Harrison, R., Maher, E. R. and Reardon, W. (2007) 'A survey of assisted reproductive technology births and imprinting disorders', *Hum Reprod* 22(12): 3237-40.
- Broad, K. D., Curley, J. P. and Keverne, E. B. (2009) 'Increased apoptosis during neonatal brain development underlies the adult behavioral deficits seen in mice lacking a functional paternally expressed gene 3 (Peg3)', *Dev Neurobiol* 69(5): 314-25.
- Cedar, H. and Bergman, Y. (2009) 'Linking DNA methylation and histone modification: patterns and paradigms', *Nat Rev Genet* 10(5): 295-304.
- Chang, A. S., Moley, K. H., Wangler, M., Feinberg, A. P. and Debaun, M. R. (2005) 'Association between Beckwith-Wiedemann syndrome and assisted reproductive technology: a case series of 19 patients', *Fertil Steril* 83(2): 349-54.
- Cox, G. F., Burger, J., Lip, V., Mau, U. A., Sperling, K., Wu, B. L. and Horsthemke, B. (2002) 'Intracytoplasmic sperm injection may increase the risk of imprinting defects', *Am J Hum Genet* 71(1): 162-4.
- Curley, J. P., Barton, S., Surani, A. and Keverne, E. B. (2004) 'Coadaptation in mother and infant regulated by a paternally expressed imprinted gene', *Proc Biol Sci* 271(1545): 1303-9.
- Davis, T. L., Yang, G. J., McCarrey, J. R. and Bartolomei, M. S. (2000) 'The H19 methylation imprint is erased and re-established differentially on the parental alleles during male germ cell development', *Hum Mol Genet* 9(19): 2885-94.
- DeBaun, M. R., Niemitz, E. L. and Feinberg, A. P. (2003) 'Association of in vitro fertilization with Beckwith-Wiedemann syndrome and epigenetic alterations of LIT1 and H19', *Am J Hum Genet* 72(1): 156-60.
- Deng, Y. and Wu, X. (2000) 'Peg3/Pw1 promotes p53-mediated apoptosis by inducing Bax translocation from cytosol to mitochondria', *Proc Natl Acad Sci U S A* 97(22): 12050-5.

- Fauque, P., Jouannet, P., Lesaffre, C., Ripoche, M. A., Dandolo, L., Vaiman, D. and Jammes, H. (2007) 'Assisted Reproductive Technology affects developmental kinetics, H19 Imprinting Control Region methylation and H19 gene expression in individual mouse embryos', *BMC Dev Biol* 7: 116.
- Fortier, A. L., Lopes, F. L., Darricarrere, N., Martel, J. and Trasler, J. M. (2008) 'Superovulation alters the expression of imprinted genes in the midgestation mouse placenta', *Hum Mol Genet* 17(11): 1653-65.
- Geuns, E., De Rycke, M., Van Steirteghem, A. and Liebaers, I. (2003) 'Methylation imprints of the imprint control region of the SNRPN-gene in human gametes and preimplantation embryos', *Hum Mol Genet* 12(22): 2873-9.
- Gicquel, C., Gaston, V., Mandelbaum, J., Siffroi, J. P., Flahault, A. and Le Bouc, Y. (2003) 'In vitro fertilization may increase the risk of Beckwith-Wiedemann syndrome related to the abnormal imprinting of the KCN1OT gene', *Am J Hum Genet* 72(5): 1338-41.
- Gosden, R., Trasler, J., Lucifero, D. and Faddy, M. (2003) 'Rare congenital disorders, imprinted genes, and assisted reproductive technology', *Lancet* 361(9373): 1975-7.
- Halliday, J., Oke, K., Breheny, S., Algar, E. and D, J. A. (2004) 'Beckwith-Wiedemann syndrome and IVF: a case-control study', *Am J Hum Genet* 75(3): 526-8.
- Johnson, M. D., Wu, X., Aithmitti, N. and Morrison, R. S. (2002) 'Peg3/Pw1 is a mediator between p53 and Bax in DNA damage-induced neuronal death', *J Biol Chem* 277(25): 23000-7.
- Katari, S., Turan, N., Bibikova, M., Erinle, O., Chalian, R., Foster, M., Gaughan, J. P., Coutifaris, C. and Sapienza, C. (2009) 'DNA methylation and gene expression differences in children conceived in vitro or in vivo', *Hum Mol Genet* 18(20): 3769-78.
- Kato, Y., Rideout, W. M., 3rd, Hilton, K., Barton, S. C., Tsunoda, Y. and Surani, M. A. (1999) 'Developmental potential of mouse primordial germ cells', *Development* 126(9): 1823-32.
- Khoueir, R., Ibala-Rhomdane, S., Mery, L., Blachere, T., Guerin, J. F., Lornage, J. and Lefevre, A. (2008) 'Dynamic CpG methylation of the KCNQ1OT1 gene during maturation of human oocytes', *J Med Genet* 45(9): 583-8.
- Lee, J., Inoue, K., Ono, R., Ogonuki, N., Kohda, T., Kaneko-Ishino, T., Ogura, A. and Ishino, F. (2002) 'Erasing genomic imprinting memory in mouse clone embryos produced from day 11.5 primordial germ cells', *Development* 129(8): 1807-17.
- Li, L., Keverne, E. B., Aparicio, S. A., Ishino, F., Barton, S. C. and Surani, M. A. (1999) 'Regulation of maternal behavior and offspring growth by paternally expressed Peg3', *Science* 284(5412): 330-3.
- Lim, D., Bowdin, S. C., Tee, L., Kirby, G. A., Blair, E., Fryer, A., Lam, W., Oley, C., Cole, T., Brueton, L. A. et al. (2009) 'Clinical and molecular genetic features of Beckwith-Wiedemann syndrome associated with assisted reproductive technologies', *Hum Reprod* 24(3): 741-7.

- Liu, J. H., Yin, S., Xiong, B., Hou, Y., Chen, D. Y. and Sun, Q. Y. (2008) 'Aberrant DNA methylation imprints in aborted bovine clones', *Mol Reprod Dev* 75(4): 598-607.
- Lucifero, D., Mann, M. R., Bartolomei, M. S. and Trasler, J. M. (2004) 'Gene-specific timing and epigenetic memory in oocyte imprinting', *Hum Mol Genet* 13(8): 839-49.
- Ludwig, M., Katalinic, A., Gross, S., Sutcliffe, A., Varon, R. and Horsthemke, B. (2005) 'Increased prevalence of imprinting defects in patients with Angelman syndrome born to subfertile couples', *J Med Genet* 42(4): 289-91.
- Maher, E. R. (2005) 'Imprinting and assisted reproductive technology', *Hum Mol Genet* 14 Spec No 1: R133-8.
- Maher, E. R., Brueton, L. A., Bowdin, S. C., Luharia, A., Cooper, W., Cole, T. R., Macdonald, F., Sampson, J. R., Barratt, C. L., Reik, W. et al. (2003) 'Beckwith-Wiedemann syndrome and assisted reproduction technology (ART)', *J Med Genet* 40(1): 62-4.
- Mann, M. R., Chung, Y. G., Nolen, L. D., Verona, R. I., Latham, K. E. and Bartolomei, M. S. (2003) 'Disruption of imprinted gene methylation and expression in cloned preimplantation stage mouse embryos', *Biol Reprod* 69(3): 902-14.
- Mann, M. R., Lee, S. S., Doherty, A. S., Verona, R. I., Nolen, L. D., Schultz, R. M. and Bartolomei, M. S. (2004) 'Selective loss of imprinting in the placenta following preimplantation development in culture', *Development* 131(15): 3727-35.
- Murphy, S. K., Wylie, A. A. and Jirtle, R. L. (2001) 'Imprinting of PEG3, the human homologue of a mouse gene involved in nurturing behavior', *Genomics* 71(1): 110-7.
- Orstavik, K. H., Eiklid, K., van der Hagen, C. B., Spetalen, S., Kierulf, K., Skjeldal, O. and Buiting, K. (2003) 'Another case of imprinting defect in a girl with Angelman syndrome who was conceived by intracytoplasmic semen injection', *Am J Hum Genet* 72(1): 218-9.
- Paoloni-Giacobino, A. and Chaillet, J. R. (2004) 'Genomic imprinting and assisted reproduction', *Reprod Health* 1(1): 6.
- Pfeifer, K. (2000) 'Mechanisms of genomic imprinting', *Am J Hum Genet* 67(4): 777-87.
- Razin, A. and Riggs, A. D. (1980) 'DNA methylation and gene function', *Science* 210(4470): 604-10.
- Reese, K. J., Lin, S., Verona, R. I., Schultz, R. M. and Bartolomei, M. S. (2007) 'Maintenance of paternal methylation and repression of the imprinted H19 gene requires MBD3', *PLoS Genet* 3(8): e137.
- Relaix, F., Wei, X., Li, W., Pan, J., Lin, Y., Bowtell, D. D., Sassoon, D. A. and Wu, X. (2000) 'Pw1/Peg3 is a potential cell death mediator and cooperates with Siah1a in p53-mediated apoptosis', *Proc Natl Acad Sci U S A* 97(5): 2105-10.
- Roberts, R. M. (2005) 'Embryo culture conditions: what embryos like best', *Endocrinology* 146(5): 2140-1.
- Sato, A., Otsu, E., Negishi, H., Utsunomiya, T. and Arima, T. (2007) 'Aberrant DNA methylation of imprinted loci in superovulated oocytes', *Hum Reprod* 22(1): 26-35.

- Shah, P. S., Weksberg, R. and Chitayat, D. (2006) 'Overgrowth with severe developmental delay following IVF/ICSI: A newly recognized syndrome?', *Am J Med Genet A* 140(12): 1312-5.
- Stadtmauer, L., Ditkoff, E. C., Session, D. and Kelly, A. (1994) 'High dosages of gonadotropins are associated with poor pregnancy outcomes after in vitro fertilization-embryo transfer', *Fertil Steril* 61(6): 1058-64.
- Stouder, C., Deutsch, S. and Paoloni-Giacobino, A. (2009) 'Superovulation in mice alters the methylation pattern of imprinted genes in the sperm of the offspring', *Reprod Toxicol* 28(4): 536-41.
- Sunderam, S., Chang, J., Flowers, L., Kulkarni, A., Sentelle, G., Jeng, G. and Macaluso, M. (2009) 'Assisted reproductive technology surveillance--United States, 2006', *MMWR Surveill Summ* 58(5): 1-25.
- Szabo, P. E. and Mann, J. R. (1995) 'Allele-specific expression and total expression levels of imprinted genes during early mouse development: implications for imprinting mechanisms', *Genes Dev* 9(24): 3097-108.
- Tremblay, K. D., Duran, K. L. and Bartolomei, M. S. (1997) 'A 5' 2-kilobase-pair region of the imprinted mouse H19 gene exhibits exclusive paternal methylation throughout development', *Mol Cell Biol* 17(8): 4322-9.
- Tremblay, K. D., Saam, J. R., Ingram, R. S., Tilghman, S. M. and Bartolomei, M. S. (1995) 'A paternal-specific methylation imprint marks the alleles of the mouse H19 gene', *Nat Genet* 9(4): 407-13.
- Van der Auwera, I. and D'Hooghe, T. (2001) 'Superovulation of female mice delays embryonic and fetal development', *Hum Reprod* 16(6): 1237-43.
- Verona, R. I., Mann, M. R. and Bartolomei, M. S. (2003) 'Genomic imprinting: intricacies of epigenetic regulation in clusters', *Annu Rev Cell Dev Biol* 19: 237-59.
- Young, E., Kenny, A., Puigdomenech, E., Van Thillo, G., Tiveron, M. and Piazza, A. (1998) 'Triplet pregnancy after intracytoplasmic sperm injection of cryopreserved oocytes: case report', *Fertil Steril* 70(2): 360-1.

## **Chapter 3: The Effects of Embryo Culture on Genomic Imprinting: Comparing 5 Commercially Available Media**

The work in this chapter originates from the following peer-reviewed article:

Market-Velker, B. A., Fernandes, A. D. and Mann, M. R. Side-by-side comparison of five commercial media systems in a mouse model: sub-optimal *in vitro* culture interferes with imprint maintenance. *Biol Reprod* 83(6): 938-50 (2010)

### **3.1 Introduction**

Generally, assisted reproductive technologies (ARTs) are considered safe medical treatments. There has been little concern that children conceived by ARTs are less healthy than naturally-conceived children. However, while absolute risks remain low, evidence indicates that children conceived by ARTs are at an increased risk of intrauterine growth restriction, premature birth, low birth weight (Schieve et al., 2002; Sunderam et al., 2009), as well as genomic imprinting disorders (Cox et al., 2002; DeBaun et al., 2003; Gicquel et al., 2003; Orstavik et al., 2003; Halliday et al., 2004; Chang et al., 2005; Ludwig et al., 2005). Thus, it is important to monitor the consequences of manipulating embryos especially with the rapid evolution and increased use of ARTs.

An important protocol employed in assisted reproduction is *in vitro* culture. While steady progress in developing improved culture conditions for mammalian embryos has occurred over the past 50 years (Gardner, 1994; Edwards et al., 1997; Kaffer et al., 2001), current culture media remain suboptimal. Cultured embryos from all species

have reduced pregnancy rates, reduced viability and growth, increased developmental abnormalities, behavioural deviations, are prone to metabolic and growth disorders, and display aberrant expression patterns when compared to *in vivo* counterparts (Bowman and McLaren, 1970; Ho et al., 1995; Sasaki et al., 1995; Walker et al., 1996; Young et al., 1998; Sinclair et al., 1999; Barker, 2000; Doherty et al., 2000; Khosla et al., 2001; Bertolini et al., 2002; Ecker et al., 2004; Fernandez-Gonzalez et al., 2004; Rinaudo and Schultz, 2004). Simply stated, oviductal fluid is more complex than any culture medium currently used, containing key metabolites and/or growth factors that are either lacking or are present at different concentrations in commercial media systems. In addition, oviductal fluid is dynamic, changing along the length of the female reproductive tract to reflect altered metabolic preferences in the embryo (Roberts, 2005).

One of the leading explanations for these culture-induced abnormalities is epigenetic alterations in gene expression that originate from embryo manipulation. As preimplantation development is a critical period of developmental programming (Santos and Dean, 2004), the ability to maintain imprinting during *in vitro* development has been questioned. Results demonstrate that imprinting can be disrupted during mouse preimplantation development, pinpointing a critical period of susceptibility to environmental conditions (Sasaki et al., 1995; Doherty et al., 2000; Mann et al., 2004). In humans, assisted reproduction has been linked to epigenetic errors that produce the human imprinting disorders Angelman and Beckwith-Wiedemann Syndromes (AS and BWS), with loss of imprinting more often the cause of imprinting disorders in ART- compared to non-ART children (Cox et al., 2002; DeBaun et al., 2003; Gicquel et al.,

2003; Orstavik et al., 2003; Halliday et al., 2004; Chang et al., 2005; Ludwig et al., 2005).

Thus, the adverse influence of assisted reproductive technologies has significant clinical ramifications.

Multiple media formulations are used for culture in animal research models as well as human clinics (Gardner, 1994; Bavister, 1995; Gardner and Lane, 1998; Biggers and Summers, 2008). Early development of chemically-defined culture media was based on classic formulations for somatic cells. For example, Whitten's medium is a physiological saline based on Krebs-Ringer's solution supplemented with a carbohydrate energy source (Whitten et al., 1971). Here, we consider Whitten's media as a "worst case scenario" as it produces more aberrant non-imprinted gene expression, imprinted gene expression, and imprinted DNA methylation at the blastocyst stage (Doherty et al., 2000; Weksberg et al., 2001; Mann et al., 2004; Rinaudo and Schultz, 2004). More recent formulations have adjusted concentrations of various components based on optimized-response by embryos or approximate values of known constituents in the oviductal/uterine environment (Leese and Barton, 1984). Examples are potassium modified, simplex optimized medium (KSOM) (Lawitts and Biggers, 1993) and Human Tubal Fluid (Quinn et al., 1985). Identification of amino acids in oviducts led to supplementation of culture media with amino acids (Ho et al., 1995; Roberts, 2005). Further development was based on the premise that media should be altered during culture to better represent the changing *in vivo* environment. This resulted in development and implementation of "sequential media systems" (Gardner and Lane, 1998), where high pyruvate, low glucose medium is switched to high glucose, low pyruvate medium to reflect the embryo's

changing carbohydrate preference during preimplantation development (Leese and Barton, 1984). Many sequential media systems have been developed, including growth media, G1 and G2, and Preimplantation 1 and Multiblast media. While two-step culture systems now predominate in human ART, it is unclear whether they are “superior” or necessary (Leese and Barton, 1984; Quinn et al., 1985; Lawitts and Biggers, 2003; Biggers and Summers, 2008).

We hypothesize that imprinting maintenance mechanisms are disrupted by *in vitro* culture during mouse and human ARTs and that media systems better able to maintain genomic imprinting will produce embryos that exhibit imprinting patterns more similar to *in vivo*-derived than Whitten’s cultured embryos. In this study, we used a mouse model system because few studies are performed on human preimplantation embryos due to ethical restrictions; the effects of embryo culture need to be evaluated in a system where subfertility is not a confounding issue; and because the mouse embryo has been and is currently used to optimize culture conditions for human preimplantation embryos (Quinn and Horstman, 1998; Summers and Biggers, 2003). We compared five commercial culture systems against a classic medium formulation, Whitten’s (“worst case scenario”), as well as *in vivo*-derived embryos (“best case scenario”), to determine their effects on genomic imprinting. Imprinted methylation and expression were examined at *H19*, small nuclear ribonucleoprotein N (*Snrpn*) and paternally-expressed gene 3 (*Peg3*).

### **3.2 Materials and Methods**



### **3.2.1 Embryo Collection**

Embryos were obtained from naturally-mated C57BL6(CAST7) [B6(CAST7)] females crossed with C57BL6 (B6) males (Charles River, St Constant, Canada) as described (Mann et al., 2004; Market-Velker et al., 2010a). Briefly, B6(CAST7) females were checked for estrus and mated with B6 males. Pregnancy was determined (vaginal plug) the morning following mating (0.5 days postcoitum; dpc). Embryos were flushed from isolated oviducts at 1.5 dpc to recover 2-cell stage embryos. For hormone treatment groups, 6.25 IU PMSG (Pregnant Mare's Serum Gonadotropin, Intervet Canada, Whitby, Canada) was administered to female B6(CAST7) mice, followed by 6.25 IU hCG (Human Serum Chorionic Gonadotropin, Intervet Canada, Whitby, Canada) 40-44 hours later (Table 3.1). Hormone treatment was conducted using 6.25 IU dosage, as lower concentrations were not as effective at inducing superovulation in the B6(CAST7) mice. Experiments were performed in compliance with guidelines set by the Canadian Council for Animal Care, and the policies and procedures approved by the University of Western Ontario Council on Animal Care.

### **3.2.2 Embryo Culture**

Embryos were cultured in six different media systems, two used for mouse embryo culture [Whitten's (produced in-house) (Whitten, 1971), and KSOM with amino acids (KSOMaa; Millipore, Terneacula, USA)], and four currently used in human clinics; two non-sequential [Human Tubal Fluid (HTF; LifeGlobal, Guelph, Canada), and Global

**Table 3.1: Timeline for Spontaneous / Induced Ovulation and Culture**

Culture system	Day -3 1600 h <sup>a</sup>	Day -1 1400-1500 h <sup>a</sup>	Day -1 >1500 h <sup>b</sup>	Day 0 900 h	Day 0 >1600 h <sup>c</sup>	Day 1 900 h <sup>c</sup>
Whittens	Spont ovul	Spont ovul	Equilibrate mineral oil	Matings	Plugs	Equilibrate culture drop
Whittens	6.25 IU eCG	6.25 IU hCG	Equilibrate mineral oil	Matings	Plugs	Equilibrate culture drop
KSOMaa/Global/HTF	Spont ovul	Spont ovul	Equilibrate mineral oil	Matings	Plugs	Equilibrate culture drop
KSOMaa/Global/HTF	6.25 IU eCG	6.25 IU hCG	Equilibrate mineral oil	Matings	Plugs	Equilibrate culture drop
P1/MB	Spont ovul	Spont ovul	Equilibrate mineral oil	Matings	Plugs	Equilibrate culture drop
P1/MB	6.25 IU eCG	6.25 IU hCG	Equilibrate mineral oil	Matings	Plugs	Equilibrate culture drop
G1.5/G2.5	Spont ovul	Spont ovul	Equilibrate mineral oil	Matings	Plugs	Equilibrate culture drop
G1.5/G2.5	6.25 IU eCG	6.25 IU hCG	Equilibrate mineral oil	Matings	Plugs	Equilibrate culture drop

Culture system	Day 1 1200 h <sup>d</sup>	Day 1 > 1600 h <sup>c</sup>	Day 2 900 h <sup>d</sup>	Day 4 1200 h
Whittens	Flush 2-cell Culture embryos			Collect blastocysts Freeze
Whittens	Flush 2-cell Culture embryos			Collect blastocysts Freeze
KSOMaa/Global/HTF	Flush 2-cell Culture embryos			Collect blastocysts Freeze
KSOMaa/Global/HTF	Flush 2-cell Culture embryos			Collect blastocysts Freeze
P1/MB	Flush 2-cell Culture embryos	Equilibrate 2nd culture drop	Culture embryos	Collect blastocysts Freeze
P1/MB	Flush 2-cell Culture embryos	Equilibrate 2nd culture drop	Culture embryos	Collect blastocysts Freeze
G1.5/G2.5	Flush 2-cell Culture embryos	Equilibrate 2nd culture drop	Wash in G-MOPS+ Culture embryos	Collect blastocysts Freeze
G1.5/G2.5	Flush 2-cell Culture embryos	Equilibrate 2nd culture drop	Wash in G-MOPS+ Culture embryos	Collect blastocysts Freeze

<sup>a</sup> Spont ovul, spontaneous ovulated; 6.25 IU, induced ovulated.

<sup>b</sup> Equilibrate mineral oil; filter-sterilized mineral oil in incubator for equilibration (lid loosened).

<sup>c</sup> Equilibrate culture drop; culture drops prepared, under oil, in incubator for equilibration.

<sup>d</sup> Culture embryos, culture ~one 2-cell embryo per microliter medium.

Medium (LifeGlobal)], and two sequential systems [Preimplantation 1/Multiblast (P1/MB; Somagen Diagnostics Inc, Edmonton, Canada), and G1v5PLUS/G2v5PLUS (G1.5/G2.5; Vitrolife, Goteborg, Sweden )] (Table 3.1). The commercial media systems were used according to the manufacturer's instructions for the Mouse Embryo Assay. Where indicated by the manufacturer (Global 4 mg/mL; HTF 4 mg/mL; P1/MB 0.5%), media were supplemented with BSA (Cat# A3311, Sigma, Oakville, Canada). Mineral oil (Sigma, Oakville, Canada) was filter sterilized and equilibrated at least 48 hours prior to culture. Culture drops were prepared prior to 9 AM on the morning of collection for Whitten's and KSOMaa, or after 4 PM the day prior to collection for the remaining media to allow for equilibration. Embryos were cultured in drops of 20  $\mu$ l containing ~20 embryos. Culture conditions for Whitten's medium were 37°C, 5% CO<sub>2</sub> in air, and 37°C, 5 %O<sub>2</sub>, 5% CO<sub>2</sub>, 90% N<sub>2</sub> for the others. For sequential culture systems, the second medium drops (MB or G2.5) were prepared the day prior to transfer (after 4 PM), and equilibrated overnight. Prior to culture in G2.5, embryos were washed 2X in pre-equilibrated GMOPS+ (Vitrolife). All embryos were scored for blastocyst development (defined by the presence of a blastocoel cavity) at noon on day 4 of culture, frozen individually or in pools of 5, and stored at -80°C (Table 3.1). For each media system, embryos were recovered from multiple litters, and embryo culture was performed at least four times.

### **3.2.3 Imprinted Methylation Analysis**

Bisulfite mutagenesis and sequencing analysis was performed as described (Market-

Velker et al., 2010a), with modifications for pools of 5 blastocysts. Briefly, embryo pools were lysed in 25  $\mu$ L lysis buffer for 1 hour at 50°C, embedded in 2% low melting point agarose (Sigma, Oakville, Canada) and split into three 30  $\mu$ L beads. For each PCR reaction, 20  $\mu$ L agarose/DNA was added to one Ready-To-Go PCR Bead (RTG; GE, Baie-d'Urfe, Canada) containing gene specific primers (Supplementary Table 3.1) (Sigma, Oakville, Canada) (Market-Velker et al., 2010a) and 1  $\mu$ L 240 ng/mL tRNA (Sigma, Oakville, Canada). PCR reactions were split in half allowing for two independent PCR reactions. Negative controls (no embryo) were processed alongside each bisulfite reaction. For each sample and gene analyzed, 40-50 clones were sequenced. Chromatograms from each sequence were visualized using FinchTV (Version 1.4.0, Geospiza, Seattle, USA). Ambiguous base pairs were manually reviewed and assigned a designation (where possible). Each sequence was analyzed for total number and location of CpG associated cytosines, as well as location and number of converted and unconverted non-CpG associated cytosines to obtain conversion rates (number of converted non-CpG cytosines / total number of non-CpG cytosines). Sequences with less than 85% conversion rates were not included. Identical clones (identical location and number of unconverted CpG associated cytosines, and identical location and number of unconverted non-CpG associated cytosines) were not included. Multiple polymorphisms are present between B6 and CAST sequences at each gene analyzed, allowing parental alleles to be discriminated. Clones possessing both B6 and CAST polymorphisms were likely due to crossover during PCR amplification, and were not included. Hypermethylation of a DNA strand was defined at  $\geq$ 50% methylated CpGs on a given

strand.

### 3.2.4 Imprinted Expression Analysis

RNA isolation, synthesis of a reusable cDNA library using individual embryos, and *H19* and *Snrpn* expression analysis using the LightCycler Real Time PCR System (Roche Molecular Biochemicals, Mississauga, Canada) was performed as described (Mann et al., 2004), except HotStart RTG Beads (GE, Baie-d'Urfe, Canada) and TIB MolBiol hybridization probes (Adelphia, USA) were used (Supplementary Table 3.1). For the *Peg3* expression analysis, *Peg3* primers were used to amplify a 317-bp region (AF038939). Fluorescence resonance energy transfer hybridization probes were designed to the CAST amplicon (Supplementary Table 3.1). The *Peg3* sensor probe spans a single nucleotide polymorphism at nucleotide 3433 between B6 (T) and CAST (C) on the antisense strand. Following denaturation at 95°C for 2 minutes, PCR reactions were as follows: *H19* 95°C 1 second, 55°C 15 seconds, 72°C 25 seconds for 45 cycles, with melting curve analysis of 95°C 30 seconds, 50°C 2 minutes, with 0.2°C increments thereafter; *Snrpn* 95°C 1 second, 52°C 15 seconds, 72°C 6 seconds for 45 cycles, with melting curve analysis of 95°C 2 minutes, 45°C 2 minutes, with 0.2°C increments thereafter; *Peg3* 95°C 1 second, 53°C 15 seconds, 72°C 8 seconds for 45 cycles, with melting curve analysis of 95°C 15 seconds, 45°C 30 seconds, with 0.2°C increments thereafter. Parental allele-specific expression patterns were calculated as percent expression of the B6 or CAST allele relative to total expression of both alleles.

Monoallelic expression was defined as <10% expression from the normally silent allele (Mann et al., 2004).

### 3.2.5 Statistical Methods

In this analysis, we tested how readily methylation patterns associated with each media could be distinguished from one another through the following statistical model. Given a gene with  $n$  possible methylation sites, the frequency of observing, for a given DNA strand,  $i$  methylated sites was estimated as  $p_i$ . Specifically,  $p_0$  denotes the probability of observing no sites methylated,  $p_1$  denotes the probability of observing one methylated site, and so on for  $i = 0, 1, \dots, n$ . Plots of  $p_i$  versus media show in Figure 8a, for example, three DNA strands from the in vivo pool had  $p_i \approx 15/16$  sites methylated. Methylation-level frequencies  $p_i$  are most easily estimated from counts  $n_i$  by setting  $p_i \approx n_i/n$ , where  $n_i$  is the number of strands having  $i$  sites methylated and  $n$  is the total number of sites. However, such simplistic point-estimates are well known to exhibit considerable systematic error when  $n_i < 3$  for any  $i$  (Sokal and Rohlf, 1994). Therefore to account for both this error and the effect of finite sample sizes, a distribution for the set of frequencies  $p_i$  was estimated using standard Bayesian methods [42,43] such that  $p_0, p_1, \dots, p_n | n_0, n_1, \dots, n_n \sim \text{Dirichlet}([n_0, n_1, \dots, n_n] + 1/2)$ . Therefore, if  $m$  embryos are sampled in the future from the same media, these embryos are expected to display methylation counts  $[m_0, m_1, \dots, m_n]$  distributed according to a standard multinomial distribution with frequencies  $[p_0, p_1, \dots, p_n]$ , where  $\sum_i m_i = m$ . The combination of

Dirichlet posterior and multinomial likelihood is called the Multivariate Pólya distribution for the likelihood  $\Pr(m_0, m_1, \dots, m_n | n_0, n_1, \dots, n_n)$ , and it is the natural generalization of the bivariate Beta-binomial model [44]. Although Fisher-type p-values are often used to test if two observed data sets are "significantly" different, it is possible to instead estimate the magnitude of difference between each data set. Such estimates, when available, are often more informative than simple p-values alone (Goodman, 1999; Hubbard and Bayarri, 2003). Using the expected probabilities of observing counts  $[m_0, m_1, \dots, m_n]$ , we can ask how distinguishable the different media are among themselves and the *in vivo* sample via

$$\text{log-likelihood ratio } \log \left[ \frac{\Pr(m_0, m_1, \dots, m_n | n_0, n_1, \dots, n_n)}{\Pr(m_0, m_1, \dots, m_n | n'_0, n'_1, \dots, n'_n)} \right] \quad \text{for two media, each with}$$

methylation-level counts  $[n_0, n_1, \dots, n_n]$  and  $[n'_0, n'_1, \dots, n'_n]$ , respectively. Since *any*

combination of counts  $m_0, m_1, \dots, m_n$  are possible as long as they add to  $m$ , this log-

likelihood must be summed over every possible combination of  $m_i$  counts, conditioned on

one of either media being the *actual* source of the new samples. Formally, such a

construction is known as the Kullback-Leibler Divergence (KLD) between two

alternative hypotheses (Kullback and Leibler, 1951; Kullback, 1978). The KLD is

particularly attractive for distinguishing among alternative treatments because it is

directly interpretable as an expected (log) true-positive versus false-negative odds-ratio

for correctly classifying or distinguishing a future sample of  $m$  embryos from two

alternatives, given that one of the alternatives is correct (Neyman and Pearson, 1933;

Fawcett, 2006). The larger the KLD between different treatments, the larger the posterior odds-ratio that the future  $m$  embryos can be correctly classified, and hence the more distinguishable the two treatments are. These between-treatment comparisons appear on the off-diagonal of Figure 8. Thus the KLD can be *directly* interpreted as the magnitude of treatment-effect between different treatments. Furthermore, by using the Multivariate Pólya likelihood, sample-size variance is automatically taken into account, and these magnitudes are resistant to artificial inflation due to sampling variance (Kass and Raftery, 1995). Lastly, using the given KLD framework at no point is the assumption of normality required or used. The KLD is also useful for estimating statistical power by comparing two samples from the same treatment group by estimating the ability to recognize methylation patterns for a given treatment as having come from that treatment. These values appear on the diagonal of Figure 8. Smaller diagonal values are indicative of higher statistical power. If different sets of frequencies  $[n_0, n_1, \dots, n_n]$  and  $[n'_0, n'_1, \dots, n'_n]$  are drawn media-specific counts  $[n_0, n_1, \dots, n_n]$  and  $[n'_0, n'_1, \dots, n'_n]$ , respectively, the KLD is then interpreted as an expected (log) true-negative versus false-positive odds-ratio for being able to recognize methylation patterns for a given treatment as having come from that treatment. Therefore, larger diagonal values indicate larger posterior odds ratio that  $m$  future samples from the same population will be erroneously distinguishable and are an indication of lower than desired statistical power. Thus, for this analysis, using the diagonal as a guide, odds ratios below 20:1 were considered substantially indistinguishable, between 20:1 and 30:1 to be highly distinguishable, between 30:1 and



100:1 to be very highly distinguishable, and over 100:1 to be decisively distinguishable in approximate accordance with standard convention (Jeffreys, 1961).

With respect to the imprinted expression analysis, to compute the significance of non-random association between embryos cultured in different media types, we used the Fisher's exact test. As changes in expression were anticipated to be in only one direction (monoallelic or biallelic), a one-sided test was utilized. P-values were calculated using software provided online (<http://faculty.vassar.edu/lowry/fisher.html>) and were considered to be significant at  $p < 0.05$ .

### **3.3 Results**

In this study, we performed a side-by-side comparison of five commercial culture systems to determine the susceptibility of mouse preimplantation embryos to culture-induced epigenetic errors at three imprinted loci. The commercial media systems that were investigated were three nonrenewable, non-sequential media, KSOMaa, Global, and HTF, and two sequential systems, P1/MB and G1.5/G2.5. Commercial formulations were used to evaluate media currently used in human ART. For comparison, Whitten's medium was used as the worst-case scenario, and *in vivo*-derived embryos as the best-case scenario.

#### **3.3.1 Effects of Embryo Culture on Imprinted Methylation**

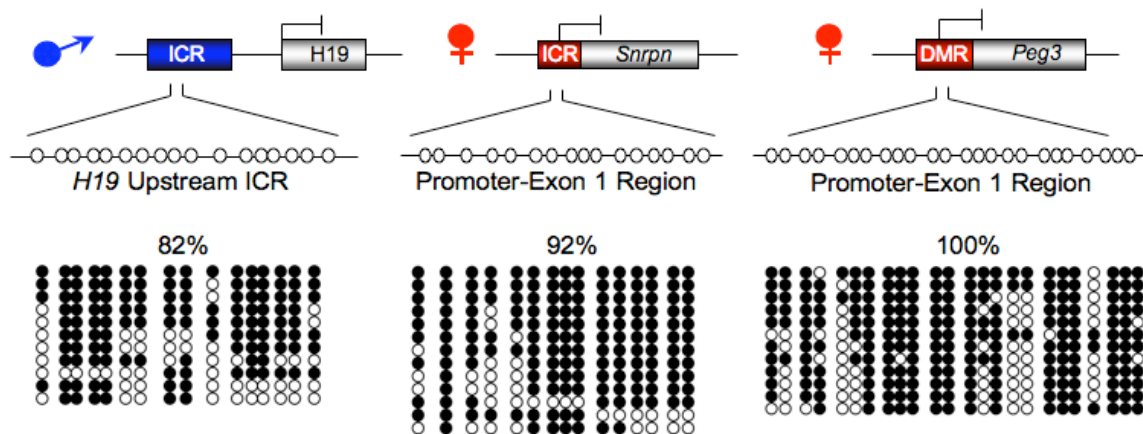
For each media system, B6(CAST7) X B6 F<sub>1</sub> embryos were cultured from the 2-cell stage to the blastocyst stage (72 ±1 hours after onset of culture) according to the manufacturer's instructions for the Mouse Embryo Assay (Table 3.1). For each media, blastocyst development was supported at a rate >90% (Whitten's 96%; KSOMaa 98%; Global 91%; HTF 97%; P1/MB 92%; G1.5/G2.5 100%) (Supplementary Table 2).

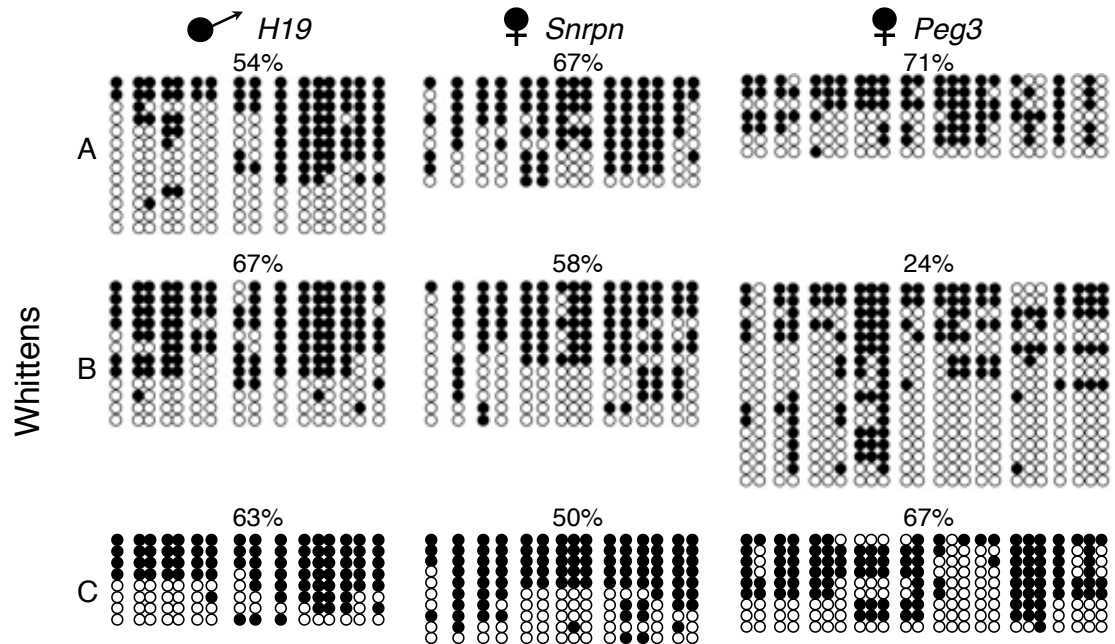
To determine whether differences existed in the ability of various culture systems to maintain genomic imprinting, DNA methylation of the *H19* and *Snrpn* imprinting control regions (ICRs), and the *Peg3* differentially methylated region (DMR) were analyzed (Figure 3.1). Methylation analyses using bisulfite mutagenesis and sequencing were performed on three pools of 5 cultured embryos per media system, and on one pool of 5 *in vivo*-derived blastocysts. The *Snrpn* ICR and the *Peg3* DMR harbour maternal-specific methylation, while the *H19* ICR possesses paternal-specific methylation (Verona et al., 2003). Therefore, in B6(CAST7) X B6 embryos, the paternal B6 *H19* allele and the maternal CAST7 *Snrpn* and *Peg3* alleles should be methylated. As anticipated from previous reports of pools of blastocysts (Tremblay et al., 1997; Thorvaldsen et al., 1998; Mann et al., 2004; Reese et al., 2007), paternal *H19* DNA strands, and maternal *Snrpn* and *Peg3* DNA strands were hypermethylated (82%, 92%, and 100%, respectively) in the *in vivo*-derived embryo pool (Figure 3.1).

Analysis of the *H19* ICR in cultured embryos (Figure 3.2-3.7) showed that Whitten's cultured embryos displayed a loss of methylation, with 54%, 67% and 63% (mean 61%) paternal DNA strands hypermethylated (Figure 3.2). Embryos cultured in all media revealed a loss of paternal-specific methylation, KSOMaa (55%, 94% and 75%;

### **Figure 3.1. Schematic Diagram of Regions Analyzed for Imprinted Methylation.**

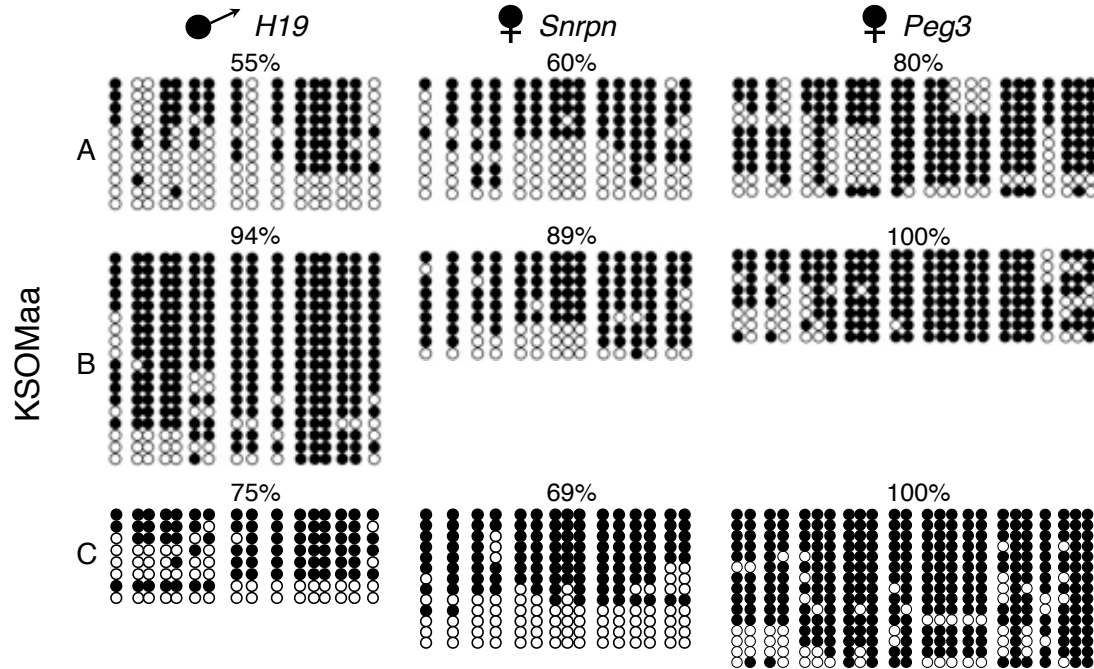
Top: The paternal methylated *H19* allele and the maternal methylated *Snrpn* and *Peg3* alleles are indicated. ICR, Imprinted Control Region. DMR, Differentially Methylated Region. Open circles, CpGs. Blunt arrow designates transcription start site of non-transcribed allele. Regions analyzed are as follows: *H19* ICR, 17 CpGs (16 CpGs in paternal B6 allele) in the ICR located 2-4 kb upstream of the transcriptional start site of *H19*; *Snrpn* ICR, 16 CpGs (15 CpGs in maternal CAST alleles) located in the promoter and first exon of the *Snrpn* gene; and *Peg3* DMR, 24 CpGs located in the promoter and first exon of the *Peg3* gene. Bottom. Methylation of the paternal *H19* ICR, and the maternal *Snrpn* ICR and *Peg3* DMR in B6(CAST7) X B6 F<sub>1</sub> *in vivo*-derived embryos (pool of 5 blastocysts). Methylation status of individual DNA strands in blastocysts derived from spontaneously ovulated females was determined by bisulfite mutagenesis and sequencing analysis. Unmethylated CpGs are represented as empty circles while methylated CpGs are depicted as filled circles. Each line denotes an individual strand of DNA. The identity of clones with identical methylation patterns and non-CpG conversion rates representing the same DNA strand were included once. Each group of DNA strands represents data from one pool of 5 embryos. Percent methylation is indicated above each set of DNA strands, and was calculated as the number of hypermethylated DNA strands / total number of DNA strands. Hypermethylated DNA strands were those displaying >50% methylated CpGs.





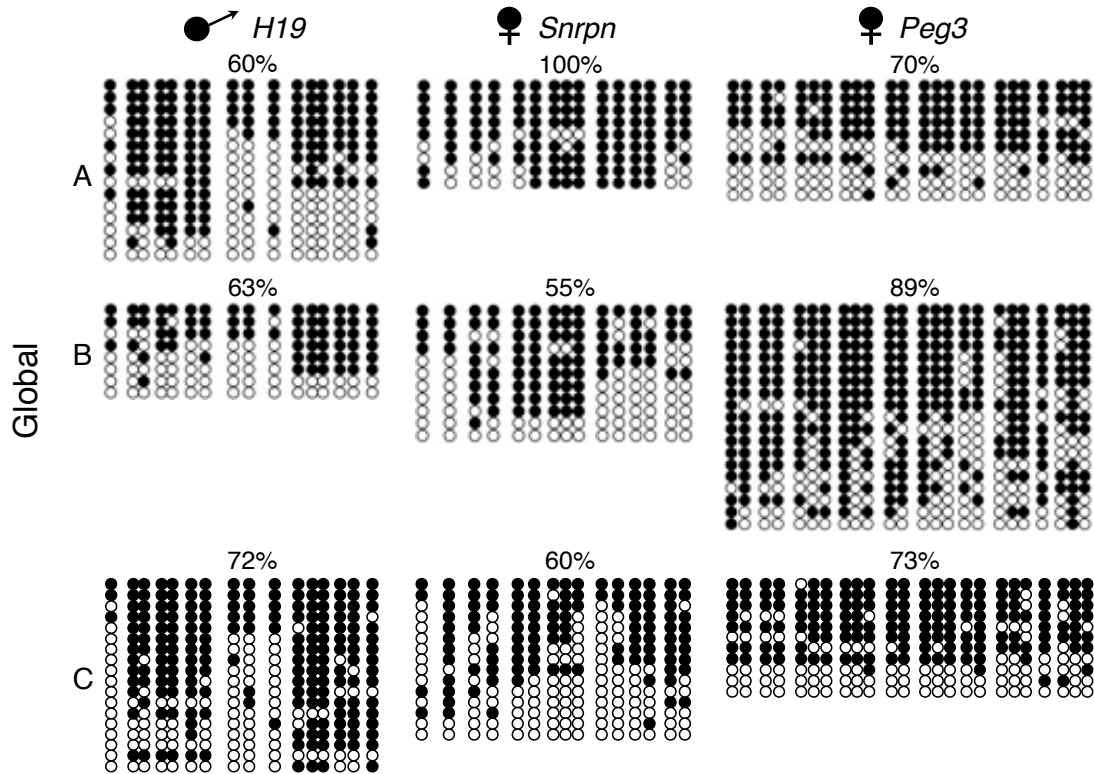
**Figure 3.2. Methylation in Whitten's Medium.**

Methylation of the paternal *H19* ICR, the maternal *Snrpn* ICR and the maternal *Peg3* DMR in B6(CAST7) X B6 F<sub>1</sub> embryos derived from spontaneously ovulated females and cultured in non-sequential Whitten's medium. Each group of DNA strands represents data from three pools of 5 embryos (A, B and C). See Figure 3.1 for additional details.



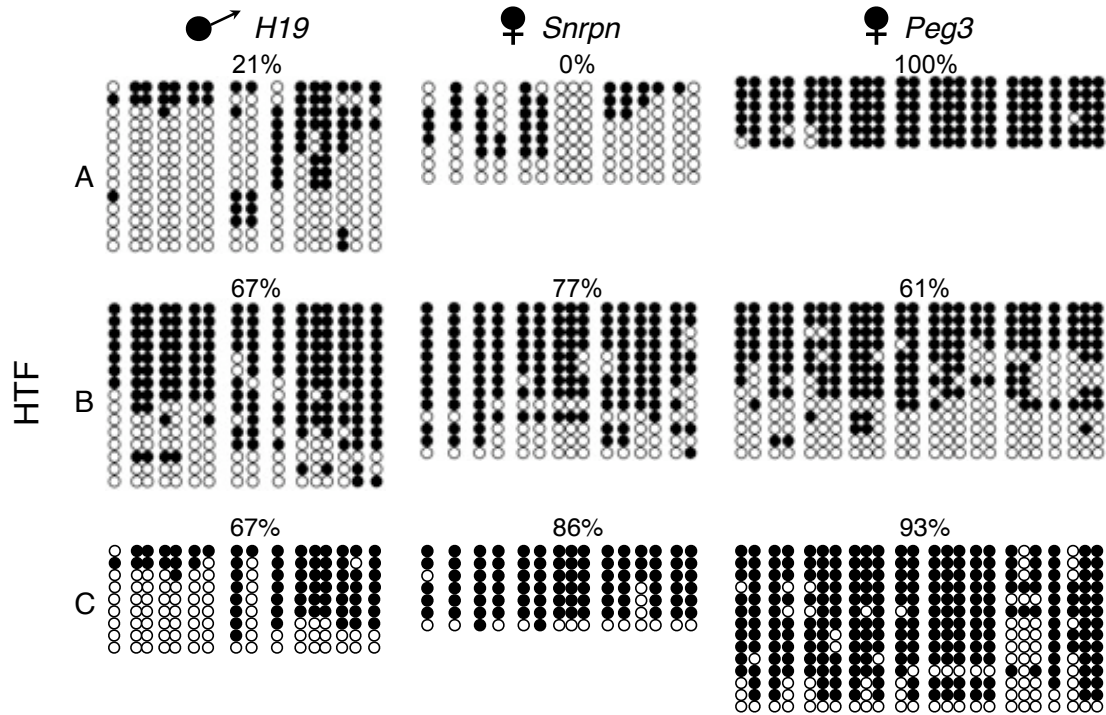
**Figure 3.3. Methylation in KSOMaa.**

Methylation of the paternal *H19* ICR, the maternal *Snrpn* ICR and the maternal *Peg3* DMR in B6(CAST7) X B6 F<sub>1</sub> embryos derived from spontaneously ovulated females and cultured in non-sequential KSOMaa. Each group of DNA strands represents data from three pools of 5 embryos (A, B and C). See Figure 3.1 for additional details.



**Figure 3.4. Methylation in Global Medium.**

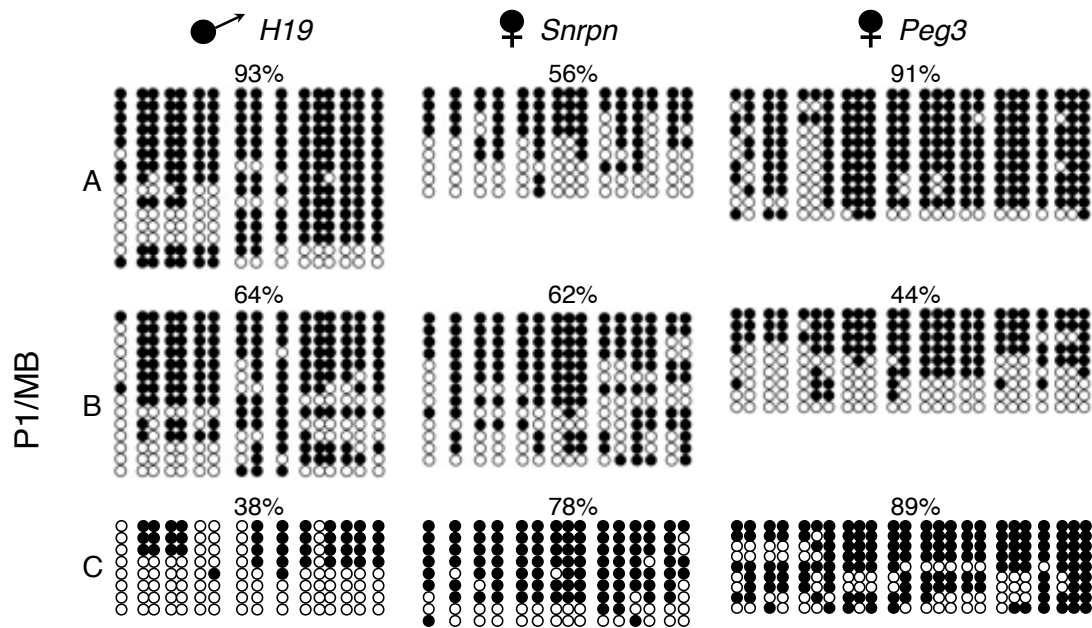
Methylation of the paternal *H19* ICR, the maternal *Snrpn* ICR and the maternal *Peg3* DMR in B6(CAST7) X B6 F<sub>1</sub> embryos derived from spontaneously ovulated females and cultured in non-sequential Global media. Each group of DNA strands represents data from three pools of 5 embryos (A, B and C). See Figure 3.1 for additional details.



**Figure 3.5. Methylation in HTF Medium.**

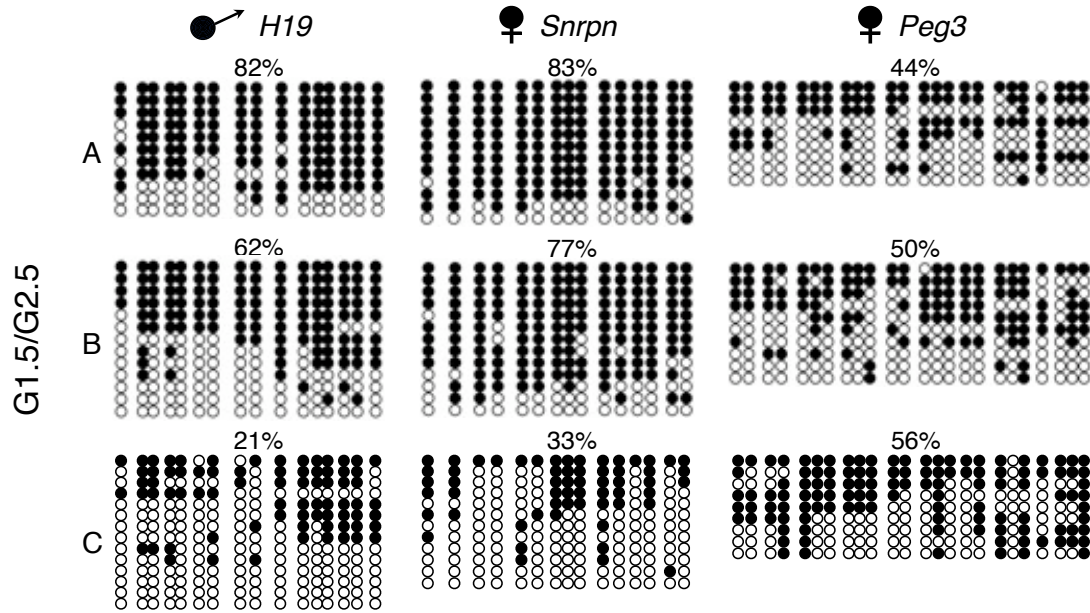
Methylation of the paternal *H19* ICR, the maternal *Snrpn* ICR and the maternal *Peg3* DMR in B6(CAST7) X B6 F<sub>1</sub> embryos derived from spontaneously ovulated females and cultured in non-sequential HTF media. Each group of DNA strands represents data from three pools of 5 embryos (A, B and C). See Figure 3.1 for additional details.





**Figure 3.6. Methylation in P1/MB Medium.**

Methylation of the paternal *H19* ICR, the maternal *Snrpn* ICR and the maternal *Peg3* DMR in B6(CAST7) X B6 F<sub>1</sub> embryos derived from spontaneously ovulated females and cultured in sequential media P1/MB. Each group of DNA strands represents data from three pools of 5 embryos (A, B and C). See Figure 3.1 for additional details.



**Figure 3.7. Methylation in G1.5/G2.5 Medium.**

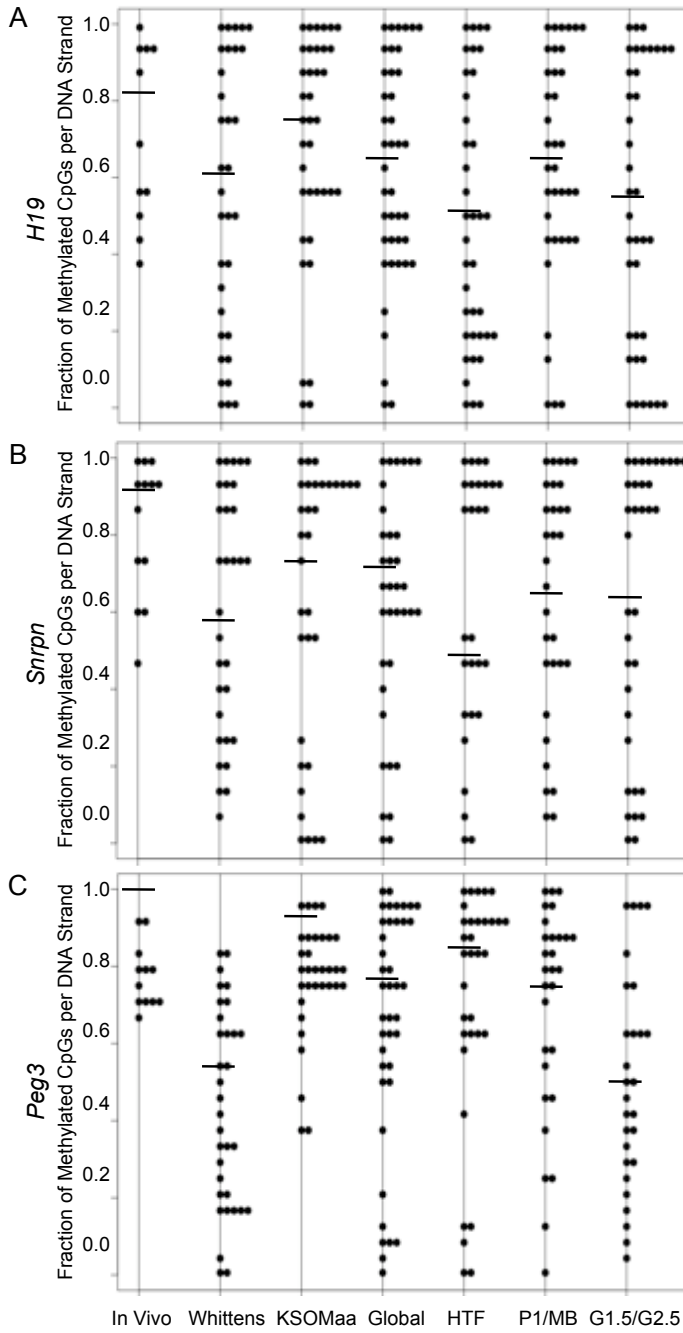
Methylation of the paternal *H19* ICR, the maternal *Snrpn* ICR and the maternal *Peg3* DMR in B6(CAST7) X B6 F<sub>1</sub> embryos derived from spontaneously ovulated females and cultured in sequential media G1.5/G2.5. Each group of DNA strands represents data from three pools of 5 embryos (A, B and C). See Figure 3.1 for additional details.

mean 75% hypermethylation), Global (60%, 63% and 72%; mean 65%), HTF (21%, 67% and 67%; mean 52%), P1/MB (93%, 64% and 38%; mean 65%), and G1.5/G2.5 (82%, 62% and 21%; mean 55%) (Figure 3.3-3.7). In these analyses, we attribute inter embryo pool variation to composition of blastocysts within the pool; variable number of blastocysts that maintained and lost imprinted methylation. This is support by our recent report on the effects of superovulation on genomic imprinting where we observed a stochastic response by individual embryos to superovulation (Market-Velker et al., 2010a).

To quantify these differences in *H19* imprinted methylation, the ability to distinguish DNA strands from embryos derived *in vivo* from those cultured in each media system were calculated as posterior odds ratios (Figure 3.8). Higher posterior odd ratios indicate a greater ability to distinguish between DNA strands obtained from embryo culture in one media compared to another (or to *in vivo*), while lower posterior odds ratios indicate an inability to distinguish between culture conditions. Using the table representing three samples (i.e. three groups of 5 embryos), this analysis demonstrated that the *in vivo*-derived embryo pool was highly distinguishable from Whitten's cultured embryos (Figure 3.8A). In addition, embryos cultured in KSOMaa, Global and P1/MB were least distinguishable from *in vivo*-derived embryos, but highly distinguishable from embryos cultured in Whitten's. Embryos cultured in HTF and G1.5/G2.5 displayed methylation levels least distinguishable from Whitten's, but were highly distinguishable from *in vivo*-derived embryos. Therefore, for *H19*, KSOMaa, Global and P1/MB appeared best able to maintain imprinted methylation. These results for embryos cultured

### Figure 3.8. Methylation Analysis

Methylation analysis of the paternal *HI9* ICR, the maternal *Snrpn* ICR and the maternal *Peg3* DMR for *in vivo*-derived and cultured embryos. Left, plots of the fraction of CpG methylation per DNA strand (black oval). Vertical bars are mean hypermethylation of embryo pools. Right, posterior odd ratios tables as calculated independently for each gene. Higher posterior odd ratios (dark grey-black) indicate a greater ability to distinguish between DNA strands obtained from embryo culture in one media compared to another (or to *in vivo*), while lower posterior odds ratios (white to light grey) indicate an inability to distinguish between culture conditions. Using the diagonal as a guide, odds ratios below 20:1 were considered substantially indistinguishable, between 20:1 and 30:1 to be highly distinguishable, between 30:1 and 100:1 to be very highly distinguishable, and over 100:1 to be decisively distinguishable.



*H19*  
3 Samples

	In vivo	Whittens	KSOMaa	Global	HTF	P1/MB	G1.5/G2.5
In vivo	11	26	14	8	12	10	13
Whittens	49	3	22	9	5	14	10
KSOMaa	16	13	3	5	12	5	9
Global	14	14	9	3	6	6	8
HTF	42	6	58	9	3	15	10
P1/MB	16	22	6	5	9	3	5
G1.5/G2.5	31	10	14	9	6	5	3

*Snrpn*  
3 Samples

	In vivo	Whittens	KSOMaa	Global	HTF	P1/MB	G1.5/G2.5
In vivo	9	10	15	17	40	12	18
Whittens	24	3	21	24	33	9	21
KSOMaa	32	22	3	33	16	13	11
Global	38	31	31	3	191	14	35
HTF	33	12	21	48	3	7	6
P1/MB	33	10	18	17	13	3	8
G1.5/G2.5	24	9	12	18	8	5	3

*Peg3*  
3 Samples

	In vivo	Whittens	KSOMaa	Global	HTF	P1/MB	G1.5/G2.5
In vivo	19	70	96	99	341	59	700
Whittens	202	5	282	106	272	193	23
KSOMaa	96	159	5	24	198	13	178
Global	109	127	79	4	26	47	43
HTF	152	263	392	13	5	48	246
P1/MB	162	162	35	34	63	6	176
G1.5/G2.5	497	28	155	36	143	152	6

in Whitten's medium and KSOMaa are consistent with our previous analysis, which showed better maintenance of *H19* imprinted methylation in KSOMaa (Mann et al., 2004).

The same embryo pools from the *H19* analysis were examined for changes in imprinted methylation at *Snrpn* and *Peg3*. For *Snrpn*, Whitten's cultured embryos displayed a loss of methylation with 67%, 58% and 50% of maternal DNA strands hypermethylated (mean 58%) (Figure 3.2). Similar to *H19*, methylation loss was observed in embryos cultured in all media, KSOMaa (60%, 89% and 69%; mean 73%), Global (100%, 55% and 60%; mean 72%), HTF (0%, 77% and 86%; mean 54% hypermethylation), P1/MB (56%, 62% and 78%; mean 65%) and G1.5/G2.5 (83%, 77% and 33%; mean 64%) (Figure 3.3-3.7).

Quantification of posterior odds ratios for *Snrpn* revealed that the *in vivo*-derived embryos were highly distinguishable from Whitten's cultured embryos. Furthermore, embryos cultured in KSOMaa, Global, HTF, P1/MB, and G1.5/G2.5 were highly distinguishable from *in vivo*-derived embryos. However, embryos cultured in HTF, P1/MB, and G1.5/G2.5 were least distinguishable from those cultured in Whitten's medium, while KSOMaa and Global cultured embryos were highly distinguishable from Whitten's cultured embryos (Figure 3.8B). Therefore, for *Snrpn*, KSOMaa and Global appeared better able to maintain imprinted methylation when compared to Whitten's, HTF, P1/MB, and G1.5/G2. Consistent with our previous study (Mann et al., 2004), we observed that embryos cultured in KSOMaa harbored greater *Snrpn* methylation than those cultured in Whitten's medium.

For the *Peg3* DMR methylation analysis, Whitten's cultured embryos displayed a loss of methylation with 71%, 24% and 67% maternal DNA strands hypermethylated (mean 54%) (Figure 3.2). Embryos cultured in G1.5/G2.5 (44%, 50% and 56%; mean 50% hypermethylation) (Figure 3.7) also produced a severe loss of *Peg3* methylation, while embryos cultured in KSOMaa (80%, 100% and 100%; mean 93% hypermethylation), Global (70%, 89% and 73%; mean 77%), HTF (100%, 61% and 93%; mean 85%) and P1/MB (91%, 44% and 89%; mean 75%) harbored higher maternal *Peg3* hypermethylation levels (Figure 3.3-3.6).

Quantification of posterior odds ratios for *Peg3* revealed that the *in vivo*-derived embryo pool was highly distinguishable from Whitten's cultured embryos (Figure 3.8C). Embryos cultured in KSOMaa were least distinguishable from *in vivo*-derived embryos and highly distinguishable from Whitten's medium. Embryos cultured in G1.5/G2.5 were highly distinguishable from *in vivo*-derived embryos and least distinguishable from Whitten's medium. Global, HTF and P1/MB cultured embryos displayed levels distinguishable from both *in vivo*-derived and Whitten's cultured embryos. Thus, for *Peg3*, KSOMaa culture appeared best able to maintain imprinted methylation,

From the imprinted methylation analysis, we conclude that all commercial media systems are suboptimal in their ability to maintain genomic imprinting as none displayed methylation levels comparable to *in vivo*-derived embryos for all three genes (Figure 3.8). Having said this, some media systems were better able to maintain imprinted methylation; KSOMaa, Global and P1/MB for *H19*, KSOMaa and Global for *Snrpn*; and KSOMaa followed by Global, HTF and P1/MB for *Peg3*. As well, there was a differential response

of imprinted genes to various culture systems as evidenced by the response of the three loci to HTF medium where the most severe loss of *H19* and *Snrpn* methylation was observed compared to other media systems, while higher methylation levels were seen for *Peg3*.

### 3.3.2 Effects of Embryo Culture on Imprinted Gene Expression

To investigate the effects of the commercial media systems on imprinted gene expression, individual embryos were analyzed for *H19*, *Snrpn* and *Peg3* imprinted expression. Approximately 20-30 individual embryos were analyzed from each media system as well as for *in vivo*-derived control embryos. For *Snrpn*, *in vivo*-derived control embryos displayed paternal-specific *Snrpn* expression (100% *Snrpn* expression, 100% monoallelic expression) (Supplementary Table 3.3). For *Peg3*, 23 of 24 control embryos (96%) expressed *Peg3* with all but one embryo exhibiting paternal-specific expression (96% monoallelic) (Supplementary Table 3.3). Analysis of cultured embryos demonstrated that *Snrpn* and *Peg3* also maintained monoallelic expression following embryo culture in all media systems, similar to *in vivo*-derived embryos, although a small percentage of embryos exhibited biallelic *Peg3* expression (4-11%), however this difference was not statistically significant (Table 3.2). These results are similar to our previous study where monoallelic *Snrpn* and *Peg3* expression were maintained in Whitten's and KSOMaa cultured embryos at the blastocyst stage (Mann et al., 2004).

Maintenance of *Snrpn* and *Peg3* imprinted expression following culture contrasted sharply with that of *H19*. Analysis of *H19* imprinted expression showed that 100% of *in*



**Table 3.2: Expression Analysis of Cultured and Superovulation and Cultured Embryos**

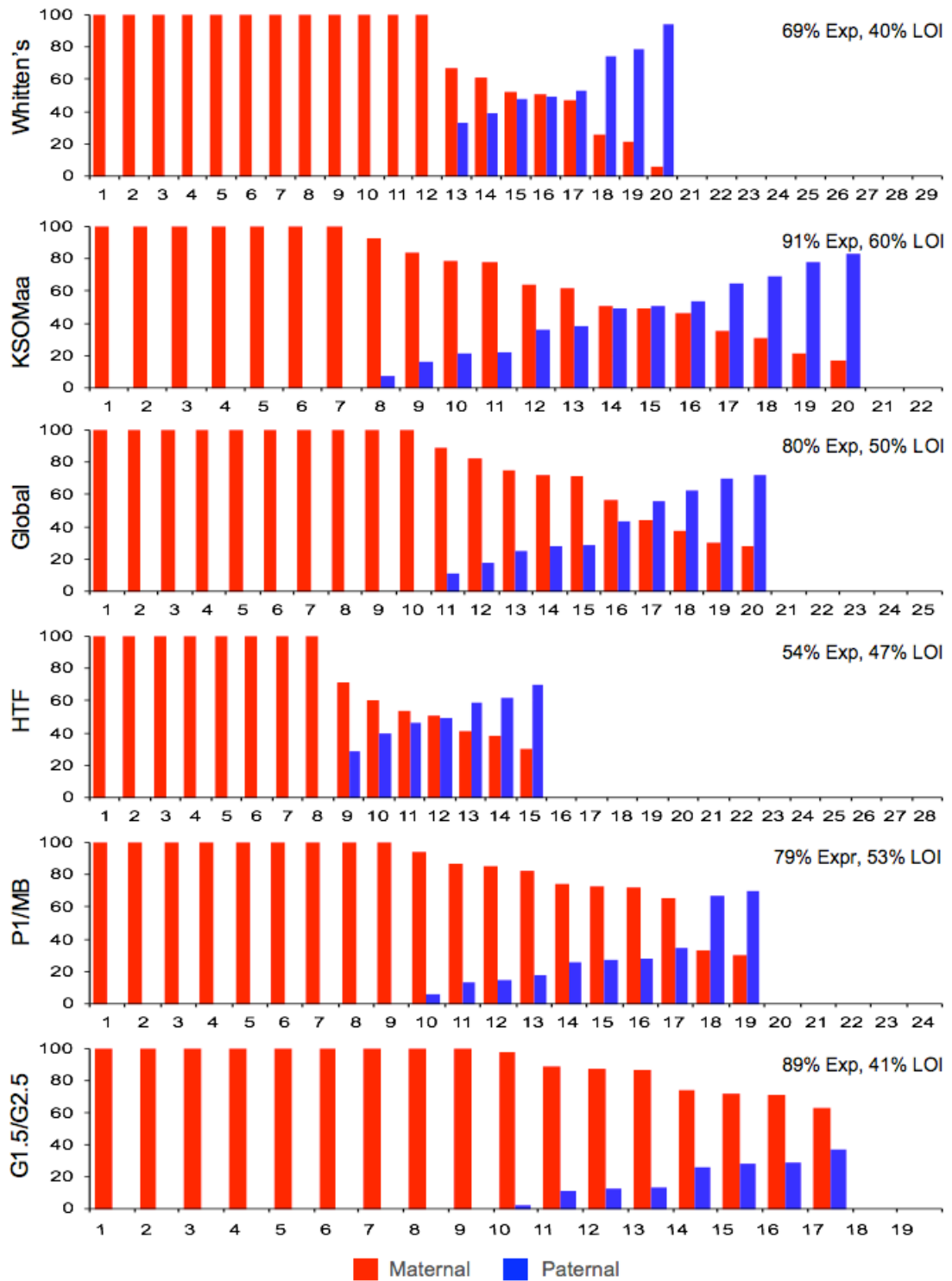
Culture media	<i>Snrpn</i>			<i>Peg3</i>		
	Analyzed	Expressed	Biallelic	Analyzed	Expressed	Biallelic
Whittens	29	29 (100%)	0	23	22 (96%)	2 (9%)
KSOMaa	22	22 (100%)	0	22	18 (82%)	0
HTF	22	22 (100%)	0	28	26 (93%)	1 (4%)
Global	25	25 (100%)	0	25	24 (96%)	1 (4%)
P1/MB	24	24 (100%)	0	24	22 (92%)	0
G1.5/G2.5	19	19 (100%)	0	19	18 (95%)	0
6.25 IU/Whittens	23	23 (100%)	0	23	23 (100%)	0
6.25 IU/KSOMaa	21	21 (100%)	0	22	21 (95%)	0
6.25 IU/Global	21	21 (100%)	0	21	21 (100%)	0
6.25 IU/HTF	22	22 (100%)	0	22	21 (95%)	1 (5%)
6.25 IU/P1/MB	19	19 (100%)	1 (5%)	19	19 (100%)	2 (11%)
6.25 IU/G1.5/G2.5	13	13 (100%)	0	13	13 (100%)	0

*in vivo*-derived controls displayed maternal-specific expression (Supplementary Table 3.3), while 40% of Whitten's cultured embryos displayed loss of imprinting (LOI, defined as biallelic / abnormal paternal *H19* expression) (Figure 3.9). Similar to Whitten's, all five commercial culture systems had increased numbers of embryos with loss of imprinted *H19* expression; KSOMaa 60%, Global 50%, HTF 47%, P1/MB 53%, and G1/G2 41% (Figure 3.9). No statistically significant difference in LOI was observed between all media analyzed, however there was a significant difference between all media and *in vivo*-derived embryos with respect to biallelic expression using Fisher's exact test ( $p < 0.05$ , Supplementary Table 3.4). These results are discordant from our previous study where better maintenance of *H19* imprinted expression was observed in KSOMaa compared to Whitten's culture (Mann et al., 2004). While the reason for this discordance is not clear, we do note that our current cultured embryos possess fewer cell numbers compared to those in our previous analysis. We are currently investigating the relationship between cell number and loss of imprinting.

A change in frequency of embryos expressing *H19* was also observed between experimental and control groups. Thirteen percent of *in vivo*-derived embryos expressed *H19* (9/68 embryos) (Supplementary Table 3.3), while 69% of Whitten's cultured embryos expressed *H19* (Figure 3.9). *Snrpn* was expressed in all these embryos, acting as a control for RNA isolation and cDNA synthesis. Similar to Whitten's, *H19* expression was more frequent in embryos cultured in all commercial media systems compared to *in vivo*-derived embryos; KSOMaa 91%, Global 80%, HTF 54%, P1/MB 79%, and G1/G2 89% ( $p < 0.05$ , Supplementary Table 3.5) (Figure 3.9).

### **Figure 3.9. Imprinted Expression of *H19* - Spontaneous Ovulation and Culture**

Imprinted expression of *H19* in B6(CAST7)xB6 embryos derived from spontaneously ovulated females and cultured in six different media systems. Embryo designations are indicated on the X-axis; percent allelic expression from each allele is indicated on the Y-axis. Grey bar height indicates percent of maternal expression while black bar height represents the percent of paternal-specific expression. Percent expressed (% Exp) was calculated as number of embryos displaying *H19* expression / total number of embryos analyzed, and percent loss of imprinted expression (% LOI) was calculated as number of embryos displaying >10% expression from the normally silenced allele / total number of embryos expressing *H19*.

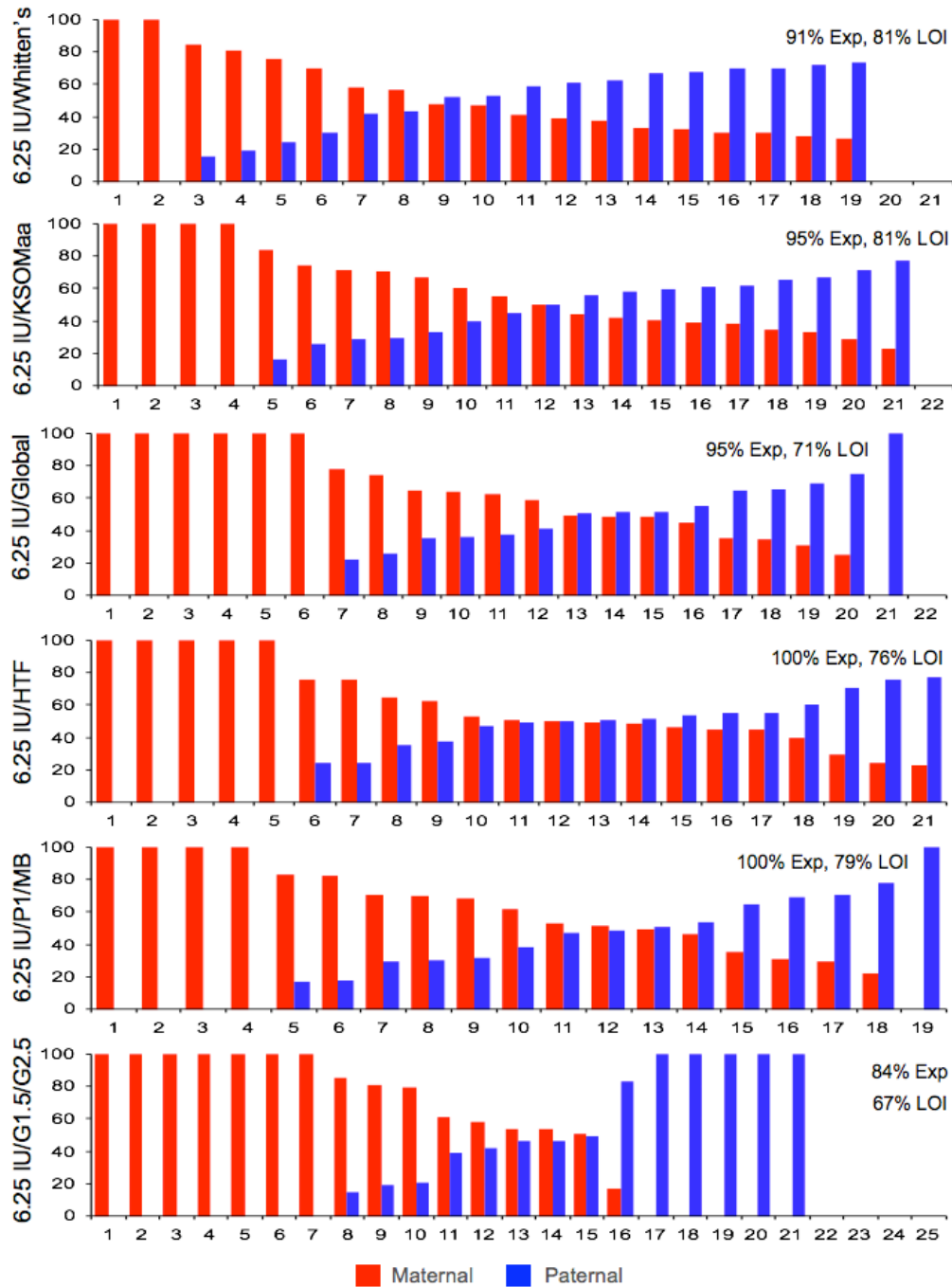


### 3.3.3 Effects of Superovulation and Embryo Culture on Imprinted Expression

In a recent study, we demonstrated that superovulation (without culture) perturbed *H19*, *Snrpn*, and *Peg3* imprinted methylation (Market-Velker et al., 2010a). To examine the effect of superovulation in combination with embryo culture, we examined *H19*, *Snrpn* and *Peg3* imprinted expression in individual embryos derived from superovulated females and cultured in each of the five commercial media systems. Since our primary goal was to determine the synergistic effects of superovulation and embryo culture, we used low hormone dosages; this treatment had less effect on imprinted methylation patterns compared to high hormone dosage (Market-Velker et al., 2010a). Blastocyst development was supported at a rate >85% in the various culture systems in combination with superovulation (6.25 IU/Whitten's 92%; 6.25 IU/KSOMaa 96%; 6.25 IU/Global 97%; 6.25 IU/HTF 89%; 6.25 IU/P1/MB 86%; 6.25 IU/G1.5/G2.5 96%) (Supplementary Table 3.2).

Similar to non-hormone treated groups, *Snrpn* and *Peg3* imprinted expression was maintained in superovulated-cultured groups (Table 3.2). For *H19*, hormone treatment in conjunction with Whitten's culture resulted in a dramatic increase in the number of embryos with loss of imprinted *H19* expression from 40% to 81% (Figure 3.9-3.10). A similar increase was observed in all five culture systems; KSOMaa 60% vs 81%; Global 50% vs 71%; HTF 47% vs 76%; P1/MB 53% vs 79%; and G1.5/G2.5 41% vs 67% for culture alone compared to combined treatment, respectively.

An overall comparison of the three paradigms, *in vivo*-derived (68 embryos), spontaneously ovulated-cultured (147 embryos) and superovulated-cultured (120



**Figure 3.10. Imprinted Expression of *H19* - Superovulation and Cultured Embryos**

Imprinted expression of *H19* in B6(CAST7)xB6 embryos derived from superovulated females and cultured in six different media systems. Details are as described in Figure 3.9.

embryos) groups, revealed that loss of imprinted expression occurred more frequently in the superovulated-cultured treatment group (73%) compared to the spontaneously ovulated-cultured treatment group (47%) and to controls (0%) ( $p < 0.01$ ) (Supplementary Table 3.6). Furthermore, *H19* was expressed in a greater percentage of embryos in the superovulated-culture group (94%) than in the spontaneously ovulated-cultured group (75%) and in *in vivo*-derived embryos (13% expression) (Supplementary Table 3.6) ( $p < 0.05$ ). These results indicated that superovulation together with embryo culture results in greater *H19* expression perturbations.

### **3.4 Discussion**

In this study, we performed a side-by-side comparison of five commercial culture systems to determine their effects on genomic imprinting. All five culture systems had compromised ability to maintain genomic imprinting compared to *in vivo*-derived embryos, although in comparison to Whitten's culture, some media systems were better able to maintain imprinted methylation. We also observed that combined treatment of superovulation and embryo culture resulted in increased disruption of genomic imprinting, as evidenced by increased loss of imprinted *H19* expression. Thus, we conclude that minimizing times in culture and number of ART procedures is important to ensure the fidelity of imprinted gene expression during preimplantation development.

#### **3.4.1 Comparison of Media Systems**

Many studies have been performed to evaluate culture systems with respect to developmental competence, epigenetic status, embryo grade (quality), development rate, implantation rate, and pregnancy rate in humans (Staessen et al., 1998; Mauri et al., 2001; Artini et al., 2004; Ben-Yosef et al., 2004; Zollner et al., 2004; Sepulveda et al., 2009; Xella et al., 2010) and mouse (Sasaki et al., 1995; Doherty et al., 2000; Ecker et al., 2004; Fernandez-Gonzalez et al., 2004; Mann et al., 2004; Li et al., 2005; Fauque et al., 2007; Rivera et al., 2008). However, comparisons between studies, even those evaluating the same culture system, remain problematic due to variations in culture parameters including type of overlay, oxygen tension, culture drop volume, serum supplement, combined procedures such as IVF/ICSI, and many more. This study is the first to provide a comparative analysis of five different, commercially available culture systems. To allow reliable comparison between media systems, all embryos were cultured with the same oil overlay and drop volume, and in the same incubator, under the same oxygen conditions (except Whitten's medium, which requires different oxygen tension than the other media formulations). Embryos were flushed from oviducts in their respective culture media, supplemented with the same lot of serum substitute (according to manufacturer's instructions for mouse embryo assay), and were handled by the same individual. Our strategy was to introduce as little variation between culture conditions as possible to allow true comparisons between systems.

Furthermore, confusion has arisen, as controversy exists in the literature regarding the best embryo culture system (Summers and Biggers, 2003; Lane and Gardner, 2007; Biggers and Summers, 2008). However, no significant advantage has been shown for one



system over another with respect to blastocyst development, implantation rates or pregnancy rates (Staessen et al., 1998; Mauri et al., 2001; Fauque et al., 2007). While blastocyst formation and embryo morphology are currently the best predictors available for assessing embryo quality, they may not necessarily be predictive of epigenetic health. Thus, understanding effects of embryo culture at the molecular level is essential. As such, we set out to determine whether one culture media system was more favourable for imprint maintenance during preimplantation development.

An important finding from these experiments is that culture media actively used for both mice and humans generated a loss of imprinting following in vitro culture of mouse embryos. Previous studies have shown aberrant imprinted methylation following mouse embryo culture using KSOMaa and Whitten's media systems, with KSOMaa being named the better media system (Doherty et al., 2000; Mann et al., 2004). These data support our results, as we demonstrate greater *H19*, *Snrpn* and *Peg3* imprinted methylation levels in embryos cultured in KSOMaa compared to the other media system for which lower methylation levels were observed for at least one imprinted gene. However, these differences in methylation did not translate into differences in the ability to maintain *H19*, *Snrpn* or *Peg3* imprinted expression at the blastocyst stage. Imprinted expression was maintained for *Snrpn* and *Peg3* in all media systems while *H19* displayed similar levels of biallelic expression in all media systems when compared to control embryos.

There are number of explanations for this discordance. Firstly, *H19* imprinted expression is restricted to the trophectoderm in blastocyst stage embryos (Poirier et al.,

1991). As we observed greater imprinting perturbations in the placenta compared to the embryo proper in midgestation embryos, it may indicate that greater methylation loss occurs in trophoctoderm cells than in inner mass cells. Alternatively, differences in the ability to maintain imprinted expression in culture may relate to *Snrpn* and *Peg3* being protein-coding genes, while *H19* is a noncoding RNA. Finally, DNA methylation is but one indicator of chromatin status. As a combination of DNA methylation and histone modifications likely direct parental-specific expression, adverse effects of *in vitro* culture on histone modifications may also lead to greater misregulation of imprinted gene expression. Combined expression and methylation analyses in single blastocyst stage embryos will allow direct comparison of imprinted DNA methylation loss and loss of imprinted expression. Analysis of histone modification in blastocyst stage embryos will also provide greater insight into the effects of embryo culture on imprinted gene regulation.

A second finding from this study is that results from one gene cannot be generalized to all imprinted genes. For *H19*, embryos cultured in KSOMaa, Global and P1/MB displayed levels of *H19* imprinted methylation more similar to *in vivo*-derived embryos than other media systems. Embryos cultured in HTF and G1.5/G2.5 displayed *H19* methylation levels least distinguishable from Whitten's, but were highly distinguishable from *in vivo*-derived embryos. For *Snrpn*, while distinguishable from *in vivo*-derived embryos, KSOMaa and Global better maintained imprinted methylation than the other media systems. For *Peg3*, levels of imprinted methylation for KSOMaa cultured embryos were least distinguishable from *in vivo*, while methylation levels for

G1.5/G2.5 cultured embryos were most distinguishable from *in vivo* and least distinguishable from Whitten's. These findings illustrate the point that certain media appear to support levels of imprinted methylation similar to *in vivo*-derived embryos at some but not at all loci.

The five commercial media systems used in this study post the compounds present in the medium. However, specific concentrations are proprietary, preventing an in-depth comparison of the media systems. Based on components, KSOMaa and Global are likely the most similar media. Thus, it is not surprising that they performed similarly. HTF is likely more similar to Whitten's in that it lacks amino acids, possibly accounting for the more severe loss of methylation produced by these media. The rest of the media systems contain amino acids with the caveat that of the two-step systems, P1 contains no amino acids and G1.5 has nonessential amino acids plus methionine while both MB and G2.5 harbor essential and nonessential amino acids. For these two sequential systems, it is not readily apparent why they did not generate more similar effects on imprinted methylation loss, although it may lie in their differences. P1/MB contains the antioxidant sodium citrate while G1.5/G2.5 contains vitamins. What can be concluded is that sequential media systems did not seem to confer an advantage with respect to maintenance of genomic imprinting compared to their single step counterparts, nor did medium renewal.

### **3.4.2 Combined effects of ART treatments**

Experiments presented in Chapter 2 showed that superovulation alone can perturb imprint acquisition at multiple imprinted loci, in a dose-dependent manner. Thus, we set

out to determine whether a combination of ART treatments would lead to greater perturbation of imprinting. We observed that increased loss of *H19* imprinted expression as a result of embryo culture was exacerbated by the use of superovulation. A study by Rivera et al. also demonstrated an increase in biallelic expression of many imprinted genes following superovulation with embryo transfer compared to controls, with a further increase in biallelic expression following embryo culture combined with superovulation and embryo transfer (Rivera et al., 2008). Together, these studies demonstrate that combined ART procedures result in greater perturbation of genomic imprinting compared to single interventions.

One critical question that must be answered is how transferable these results and those of other studies are to human embryo culture. The main aim of this study was to employ commercial formulations of various culture systems to allow for evaluation of media currently used in human ART. However, the possibility remains that human embryos may not be as susceptible to culture-induced errors, or may display different sensitivities to these culture systems than the mouse. To address the question of proclivity of ART procedures to induced epigenetic errors, retrospective studies were performed on BWS children born after ARTs (DeBaun et al., 2003; Chang et al., 2005). Variable ART procedures were reported in ART-associated BWS children with no common factor emerging. Differences were observed in cause of infertility, embryo culture media (varied in glucose, amino acid and human serum albumin content), day of transfer, and ART method (IVF, ICSI, ovarian stimulation regime) employed (DeBaun et al., 2003; Chang et al., 2005). These data suggest that human embryos are susceptible to

ART-induced errors but that it is not a specific system that generates epigenetic errors. Instead, it is multiple ART procedures, such as ovarian stimulation combined with embryo culture, that pose greater risks for developing imprinting disorders. As the genes investigated in this study play an important role in early development, and genetic and epigenetic perturbations lead to imprinting disorders, we propose that culture time and number of ART procedures should be minimized to ensure fidelity of genomic imprint maintenance during development.

### 3.5 References

- Artini, P. G., Valentino, V., Cela, V., Cristello, F., Vite, A. and Genazzani, A. R. (2004) 'A randomized control comparison study of culture media (HTF versus P1) for human in vitro fertilization', *Eur J Obstet Gynecol Reprod Biol* 116(2): 196-200.
- Barker, D. J. (2000) 'In utero programming of cardiovascular disease', *Theriogenology* 53(2): 555-74.
- Bavister, B. D. (1995) 'Culture of preimplantation embryos: facts and artifacts', *Hum Reprod Update* 1(2): 91-148.
- Ben-Yosef, D., Amit, A., Azem, F., Schwartz, T., Cohen, T., Mei-Raz, N., Carmon, A., Lessing, J. B. and Yaron, Y. (2004) 'Prospective randomized comparison of two embryo culture systems: P1 medium by Irvine Scientific and the Cook IVF Medium', *J Assist Reprod Genet* 21(8): 291-5.
- Bertolini, M., Beam, S. W., Shim, H., Bertolini, L. R., Moyer, A. L., Famula, T. R. and Anderson, G. B. (2002) 'Growth, development, and gene expression by in vivo- and in vitro-produced day 7 and 16 bovine embryos', *Mol Reprod Dev* 63(3): 318-28.
- Biggers, J. D. and Summers, M. C. (2008) 'Choosing a culture medium: making informed choices', *Fertil Steril* 90(3): 473-83.
- Bowman, P. and McLaren, A. (1970) 'Viability and growth of mouse embryos after in vitro culture and fusion', *J Embryol Exp Morphol* 23(3): 693-704.
- Chang, A. S., Moley, K. H., Wangler, M., Feinberg, A. P. and Debaun, M. R. (2005) 'Association between Beckwith-Wiedemann syndrome and assisted reproductive technology: a case series of 19 patients', *Fertil Steril* 83(2): 349-54.
- Cox, G. F., Burger, J., Lip, V., Mau, U. A., Sperling, K., Wu, B. L. and Horsthemke, B. (2002) 'Intracytoplasmic sperm injection may increase the risk of imprinting defects', *Am J Hum Genet* 71(1): 162-4.
- DeBaun, M. R., Niemitz, E. L. and Feinberg, A. P. (2003) 'Association of in vitro fertilization with Beckwith-Wiedemann syndrome and epigenetic alterations of LIT1 and H19', *Am J Hum Genet* 72(1): 156-60.
- Doherty, A. S., Mann, M. R., Tremblay, K. D., Bartolomei, M. S. and Schultz, R. M. (2000) 'Differential effects of culture on imprinted H19 expression in the preimplantation mouse embryo', *Biol Reprod* 62(6): 1526-35.
- Ecker, D. J., Stein, P., Xu, Z., Williams, C. J., Kopf, G. S., Bilker, W. B., Abel, T. and Schultz, R. M. (2004) 'Long-term effects of culture of preimplantation mouse embryos on behavior', *Proc Natl Acad Sci U S A* 101(6): 1595-600.
- Edwards, L. J., Batt, P. A., Gandolfi, F. and Gardner, D. K. (1997) 'Modifications made to culture medium by bovine oviduct epithelial cells: changes to carbohydrates stimulate bovine embryo development', *Mol Reprod Dev* 46(2): 146-54.
- Fauque, P., Jouannet, P., Lesaffre, C., Ripoche, M. A., Dandolo, L., Vaiman, D. and Jammes, H. (2007) 'Assisted Reproductive Technology affects developmental kinetics, H19 Imprinting Control Region methylation and H19 gene expression in individual mouse embryos', *BMC Dev Biol* 7: 116.

- Fawcett, T. (2006) 'An introduction to ROC analysis. ', *Pattern Recognit Lett*(27): 861-874.
- Fernandez-Gonzalez, R., Moreira, P., Bilbao, A., Jimenez, A., Perez-Crespo, M., Ramirez, M. A., Rodriguez De Fonseca, F., Pintado, B. and Gutierrez-Adan, A. (2004) 'Long-term effect of in vitro culture of mouse embryos with serum on mRNA expression of imprinting genes, development, and behavior', *Proc Natl Acad Sci U S A* 101(16): 5880-5.
- Gardner, D. K. (1994) 'Mammalian embryo culture in the absence of serum or somatic cell support', *Cell Biol Int* 18(12): 1163-79.
- Gardner, D. K. and Lane, M. (1998) 'Culture of viable human blastocysts in defined sequential serum-free media', *Hum Reprod* 13 Suppl 3: 148-59; discussion 160.
- Gicquel, C., Gaston, V., Mandelbaum, J., Siffroi, J. P., Flahault, A. and Le Bouc, Y. (2003) 'In vitro fertilization may increase the risk of Beckwith-Wiedemann syndrome related to the abnormal imprinting of the KCN1OT gene', *Am J Hum Genet* 72(5): 1338-41.
- Goodman, S. (1999) 'Toward evidence-based medical statistics. 1. The p-value fallacy.', *Ann Intern Med*(130): 995-1004.
- Halliday, J., Oke, K., Breheny, S., Algar, E. and D, J. A. (2004) 'Beckwith-Wiedemann syndrome and IVF: a case-control study', *Am J Hum Genet* 75(3): 526-8.
- Ho, Y., Wigglesworth, K., Eppig, J. J. and Schultz, R. M. (1995) 'Preimplantation development of mouse embryos in KSOM: augmentation by amino acids and analysis of gene expression', *Mol Reprod Dev* 41(2): 232-8.
- Hubbard, R. and Bayarri, M. (2003) 'Confusion over measures of evidence (p's) versus errors (\_'s) in classical statistical testing.', *Am Stat*(57): 171-178.
- Jeffreys, H. (1961) *The theory of probability*, Oxford: Oxford University Press.
- Kaffer, C. R., Grinberg, A. and Pfeifer, K. (2001) 'Regulatory mechanisms at the mouse Igf2/H19 locus', *Mol Cell Biol* 21(23): 8189-96.
- Kass, R. and Raftery, A. (1995) 'Bayes Factors', *J Am Stat Asso*(90): 773-795.
- Khosla, S., Dean, W., Brown, D., Reik, W. and Feil, R. (2001) 'Culture of preimplantation mouse embryos affects fetal development and the expression of imprinted genes', *Biol Reprod* 64(3): 918-26.
- Kullback, S. (1978) *Information theory and statistics.*, New York: Dover.
- Kullback, S. and Leibler, R. (1951) 'On information and sufficiency.', *Ann Math Stat*(22): 79-86.
- Lane, M. and Gardner, D. K. (2007) 'Embryo culture medium: which is the best?', *Best Pract Res Clin Obstet Gynaecol* 21(1): 83-100.
- Lawitts and Biggers, J. D. (2003) *Culture of preimplantation embryos*, San Diego: Academic Press.
- Leese, H. J. and Barton, A. M. (1984) 'Pyruvate and glucose uptake by mouse ova and preimplantation embryos', *J Reprod Fertil* 72(1): 9-13.
- Li, T., Vu, T. H., Ulaner, G. A., Littman, E., Ling, J. Q., Chen, H. L., Hu, J. F., Behr, B., Giudice, L. and Hoffman, A. R. (2005) 'IVF results in de novo DNA methylation

- and histone methylation at an Igf2-H19 imprinting epigenetic switch', *Mol Hum Reprod* 11(9): 631-40.
- Ludwig, M., Katalinic, A., Gross, S., Sutcliffe, A., Varon, R. and Horsthemke, B. (2005) 'Increased prevalence of imprinting defects in patients with Angelman syndrome born to subfertile couples', *J Med Genet* 42(4): 289-91.
- Mann, M. R., Lee, S. S., Doherty, A. S., Verona, R. I., Nolen, L. D., Schultz, R. M. and Bartolomei, M. S. (2004) 'Selective loss of imprinting in the placenta following preimplantation development in culture', *Development* 131(15): 3727-35.
- Market-Velker, B. A., Zhang, L., Magri, L. S., Bonvissuto, A. C. and Mann, M. R. (2010a) 'Dual effects of superovulation: loss of maternal and paternal imprinted methylation in a dose-dependent manner', *Hum Mol Genet* 19(1): 36-51.
- Mauri, A. L., Petersen, C. G., Baruffi, R. L. and Franco, J. G., Jr. (2001) 'A prospective, randomized comparison of two commercial media for ICSI and embryo culture', *J Assist Reprod Genet* 18(7): 378-81.
- Neyman, J. and Pearson, E. (1933) 'On the problem of the most efficient tests of statistical hypotheses', *Philos Trans R Soc Lond A*(231): 289-337.
- Orstavik, K. H., Eiklid, K., van der Hagen, C. B., Spetalen, S., Kierulf, K., Skjeldal, O. and Buiting, K. (2003) 'Another case of imprinting defect in a girl with Angelman syndrome who was conceived by intracytoplasmic semen injection', *Am J Hum Genet* 72(1): 218-9.
- Poirier, F., Chan, C. T., Timmons, P. M., Robertson, E. J., Evans, M. J. and Rigby, P. W. (1991) 'The murine H19 gene is activated during embryonic stem cell differentiation in vitro and at the time of implantation in the developing embryo', *Development* 113(4): 1105-14.
- Quinn, P. and Horstman, F. C. (1998) 'Is the mouse a good model for the human with respect to the development of the preimplantation embryo in vitro?', *Hum Reprod* 13 Suppl 4: 173-83.
- Quinn, P., Kerin, J. F. and Warnes, G. M. (1985) 'Improved pregnancy rate in human in vitro fertilization with the use of a medium based on the composition of human tubal fluid', *Fertil Steril* 44(4): 493-8.
- Reese, K. J., Lin, S., Verona, R. I., Schultz, R. M. and Bartolomei, M. S. (2007) 'Maintenance of paternal methylation and repression of the imprinted H19 gene requires MBD3', *PLoS Genet* 3(8): e137.
- Rinaudo, P. and Schultz, R. M. (2004) 'Effects of embryo culture on global pattern of gene expression in preimplantation mouse embryos', *Reproduction* 128(3): 301-11.
- Rivera, R. M., Stein, P., Weaver, J. R., Mager, J., Schultz, R. M. and Bartolomei, M. S. (2008) 'Manipulations of mouse embryos prior to implantation result in aberrant expression of imprinted genes on day 9.5 of development', *Hum Mol Genet* 17(1): 1-14.
- Roberts, R. M. (2005) 'Embryo culture conditions: what embryos like best', *Endocrinology* 146(5): 2140-1.



- Santos, F. and Dean, W. (2004) 'Epigenetic reprogramming during early development in mammals', *Reproduction* 127(6): 643-51.
- Sasaki, H., Ferguson-Smith, A. C., Shum, A. S., Barton, S. C. and Surani, M. A. (1995) 'Temporal and spatial regulation of H19 imprinting in normal and uniparental mouse embryos', *Development* 121(12): 4195-202.
- Schieve, L. A., Meikle, S. F., Ferre, C., Peterson, H. B., Jeng, G. and Wilcox, L. S. (2002) 'Low and very low birth weight in infants conceived with use of assisted reproductive technology', *N Engl J Med* 346(10): 731-7.
- Sepulveda, S., Garcia, J., Arriaga, E., Diaz, J., Noriega-Portella, L. and Noriega-Hoces, L. (2009) 'In vitro development and pregnancy outcomes for human embryos cultured in either a single medium or in a sequential media system', *Fertil Steril* 91(5): 1765-70.
- Sinclair, K. D., McEvoy, T. G., Maxfield, E. K., Maltin, C. A., Young, L. E., Wilmut, I., Broadbent, P. J. and Robinson, J. J. (1999) 'Aberrant fetal growth and development after in vitro culture of sheep zygotes', *J Reprod Fertil* 116(1): 177-86.
- Sokal, R. and Rohlf, F. (1994) *Biometry: the principles and practice of statistics in biological research.*, New York: WH Freeman and Co.
- Staessen, C., Janssenswillen, C., De Clerck, E. and Van Steirteghem, A. (1998) 'Controlled comparison of commercial media for human in-vitro fertilization: Menezo B2 medium versus Medi-Cult universal and BM1 medium', *Hum Reprod* 13(9): 2548-54.
- Summers, M. C. and Biggers, J. D. (2003) 'Chemically defined media and the culture of mammalian preimplantation embryos: historical perspective and current issues', *Hum Reprod Update* 9(6): 557-82.
- Sunderam, S., Chang, J., Flowers, L., Kulkarni, A., Sentelle, G., Jeng, G. and Macaluso, M. (2009) 'Assisted reproductive technology surveillance--United States, 2006', *MMWR Surveill Summ* 58(5): 1-25.
- Thorvaldsen, J. L., Duran, K. L. and Bartolomei, M. S. (1998) 'Deletion of the H19 differentially methylated domain results in loss of imprinted expression of H19 and Igf2', *Genes Dev* 12(23): 3693-702.
- Tremblay, K. D., Duran, K. L. and Bartolomei, M. S. (1997) 'A 5' 2-kilobase-pair region of the imprinted mouse H19 gene exhibits exclusive paternal methylation throughout development', *Mol Cell Biol* 17(8): 4322-9.
- Verona, R. I., Mann, M. R. and Bartolomei, M. S. (2003) 'Genomic imprinting: intricacies of epigenetic regulation in clusters', *Annu Rev Cell Dev Biol* 19: 237-59.
- Walker, S. K., Hill, J. L., Kleemann, D. O. and Nancarrow, C. D. (1996) 'Development of ovine embryos in synthetic oviductal fluid containing amino acids at oviductal fluid concentrations', *Biol Reprod* 55(3): 703-8.
- Weksberg, R., Nishikawa, J., Caluseriu, O., Fei, Y. L., Shuman, C., Wei, C., Steele, L., Cameron, J., Smith, A., Ambus, I. et al. (2001) 'Tumor development in the Beckwith-Wiedemann syndrome is associated with a variety of constitutional

molecular 11p15 alterations including imprinting defects of KCNQ1OT1', *Hum Mol Genet* 10(26): 2989-3000.

Xella, S., Marsella, T., Tagliasacchi, D., Giulini, S., La Marca, A., Tirelli, A. and Volpe, A. (2010) 'Embryo quality and implantation rate in two different culture media: ISM1 versus Universal IVF Medium', *Fertil Steril* 93(6): 1859-63.

Young, E., Kenny, A., Puigdomenech, E., Van Thillo, G., Tiveron, M. and Piazza, A. (1998) 'Triplet pregnancy after intracytoplasmic sperm injection of cryopreserved oocytes: case report', *Fertil Steril* 70(2): 360-1.

Zollner, K. P., Zollner, U., Schneider, M., Dietl, J. and Steck, T. (2004) 'Comparison of two media for sequential culture after IVF and ICSI shows no differences in pregnancy rates: a randomized trial', *Med Sci Monit* 10(1): CR1-7.

## **Chapter 4: Rates of Embryo Development Correlate with Loss of Genomic**

### **Imprinting**

The work in this chapter originates from the manuscript:

Market Velker, B. A., Denomme, M. M., and Mann, M. R. Loss of Genomic Imprinting in Embryos with Rapid Rates of Preimplantation Development, submitted for publication in the journal Human Reproduction in June 2011.

#### **4.1 Introduction**

One of the first observations of deleterious effects of embryo culture is that development of mouse embryos *in vitro* results in an 18 to 24 hour lag in reaching the blastocyst stage (Bowman and McLaren, 1970; Harlow and Quinn, 1982). Since then, while culture conditions for preimplantation embryos have steadily improved (Biggers and Summers, 2008; Gardner, 2008), even the best media currently available are suboptimal for embryo development. Cultured embryos from all mammalian species have reduced viability and reduced pregnancy rates following embryo transfer, display aberrant patterns and levels of gene expression, developmental abnormalities and deviations in behaviour, and are prone to metabolic and growth disorders (Sasaki et al., 1995; Sinclair et al., 1999; Barker, 2000; Boerjan et al., 2000; Doherty et al., 2000; Khosla et al., 2001; Summers and Biggers, 2003; Ecker et al., 2004; Fernandez-Gonzalez et al., 2004; Rinaudo and Schultz, 2004; Morgan et al., 2005). Preimplantation embryos

survive *in vitro* culture by adapting to the culture environment and stresses it imposes (Niemann and Wrenzycki, 2000).

We and others have also demonstrated that preimplantation embryo culture disrupts genomic imprinting in mice (Sasaki et al., 1995; Doherty et al., 2000; Mann et al., 2004; Market-Velker et al., 2010b). *In vitro* culture of mouse preimplantation embryos results in loss of imprinted gene regulation with biallelic expression of the *H19* gene and loss of *H19*, *Snrpn* and *Peg3* imprinted methylation (Sasaki et al., 1995; Doherty et al., 2000; Mann et al., 2004; Market-Velker et al., 2010b). In Chapter 3, the comparison of six embryo culture media showed that while all were suboptimal in their ability to maintain imprinting, some media systems performed better and others were decidedly worse, such as Whitten's medium, HTF Medium and G1/G2 (Market-Velker et al., 2010b).

In humans, while the absolute risks remain low, assisted reproductive technologies have been linked to imprinting perturbations that lead to the development of Angelman Syndrome (AS) and Beckwith-Wiedemann Syndrome (BWS) (Cox et al., 2002; DeBaun et al., 2003; Maher et al., 2003; Orstavik et al., 2003; Halliday et al., 2004; Chang et al., 2005; Ludwig et al., 2005; Sutcliffe et al., 2006). In AS patients conceived by assisted reproduction, imprinting defects at the maternal *SNRPN* ICR result in loss of maternal-specific *SNRPN* methylation and the entire maternal imprinted domain acquires a paternal epigenetic identity (Cox et al., 2002; Orstavik et al., 2003; Ludwig et al., 2005; Sutcliffe et al., 2006). For BWS patients conceived by assisted reproduction, imprinting defects at the maternal *H19* ICR (2-7% patients) result in a gain of maternal-specific *H19*

methylation and overexpression of the paternally-transcribed *IGF2* gene, while imprinting defects at the *KCNQ1OT1* ICR (50% patients) result in loss of maternal-specific methylation at the *KCNQ1OT1* ICR and biallelic repression of maternally expressed genes across the imprinting domain, including *CDKN1C* (DeBaun et al., 2003; Maher et al., 2003; Halliday et al., 2004; Chang et al., 2005). The maternally-transcribed *CDKN1C/Cdkn1c* gene is an important inhibitor of the cell cycle through its interaction with cyclin-CDK complexes (Lee et al., 1995; Matsuoka et al., 1996), and its aberrant expression generates major pathologies present in BWS (Hatada and Mukai, 1995; Hatada et al., 1996; Zhang et al., 1997; Yan et al., 1997). Thus, this imprinted cell cycle regulator provides an important link between embryo development and epigenetic perturbations in the early embryo.

Imprinting marks acquired during gametogenesis must be maintained during the preimplantation epigenetic reprogramming period. However, very little is known about the mechanisms that maintain genomic imprinting in the preimplantation embryo, and how dysregulation of genomic imprinting during this time period may lead to aberrant embryonic growth and development. In mouse, cell divisions from the 2-cell to blastocyst stage occur approximately every 10-18 hours *in vivo*, with development from fertilization to blastocyst stage taking about 3.5 days (Bowman and McLaren, 1970). In contrast, embryos cultured *in vitro* to the blastocyst stage generally require an extra day of development in culture. This has led us to hypothesize that loss of imprinting during early mouse development will correlate with slower rates of embryonic development. To test our hypothesis, we separated embryos based on rates of development and examined

cell number, embryo volume, and embryo sex, together with imprinted methylation and expression at two key loci, *H19* and *Snrpn*, that are involved in the development of imprinting disorders observed in the ART population. Given the variable response of individual embryos to suboptimal culture, these analyses were performed in the same individual embryo. To explore the connection between rates of development and genomic imprinting, we also examined expression of the cell cycle inhibitor, *Cdkn1c*, on the premise that biallelic *Cdkn1c* expression will lead to slower rates of embryo development. In addition, as slower rates of development may be linked with metabolic changes, we evaluated the expression of three markers of embryonic metabolism, sodium/potassium transporting ATPase 1a1 (*Atp1a1*) which is critical for blastocoel formation (Kidder and Watson, 2005), solute carrier 2a1 (*Slc2a1/Glut1*), a glucose transporter expressed throughout preimplantation development (Pantaleon and Kaye, 1998; Augustin et al., 2001), and mitogen-activated protein kinase 14 (*Mapk14/p38* alpha) which is a signaling molecule involved in embryo response to suboptimal environments (Natale et al., 2004; Paliga et al., 2005; Fong et al., 2007) and in trophoblast differentiation (Johnstone et al., 2005; Winger et al., 2007).

This study demonstrates significant differences in cell number, embryo volume, imprinted methylation of *H19* and *Snrpn*, imprinted expression of *H19* and *Cdkn1c*, and expression of genes related to embryo metabolism between the four groups of embryos separated by rates of development in culture, and when compared to *in vivo*-derived embryos. Overall, embryos that developed the fastest contained more cells and had the largest embryo volume. However, they also had increased loss of methylation at both the

*H19* and *Snrpn* ICRs, and aberrant *H19* imprinted expression. Embryos in the slowest group that developed to the blastocyst stage demonstrated more normal levels of imprinted methylation at the *H19* and *Snrpn* ICRs, and imprinted expression of *H19*. However, nearly 40% embryos in this group arrested prior to the blastocyst stage (data not shown). Embryos with slow to moderate rates of development were most similar to *in vivo*-derived embryos, displaying cell numbers, embryo volume, *H19* and *Snrpn* methylation, *H19* imprinted expression, and *Atp1a1* and *Slc2a1* expression most similar to *in vivo*-derived embryos. We conclude that rates of preimplantation development *in vitro* are correlated with genomic imprinting and embryo metabolism, and that embryos displaying slower rates of development are likely most suitable for embryo transfer.

## **4.2 Materials and Methods**

### **4.2.1 Embryo Collection**

Embryos were obtained from naturally-mated C57BL6(CAST7partial6) [B6(CAST7p6)] females crossed with C57BL6 (B6) males (Charles River, St Constant, Canada) as described (Market-Velker et al., 2010a; Market-Velker et al., 2010b). Briefly, B6(CAST7p6) females were checked for estrus and mated with B6 males. Pregnancy was determined (vaginal plug) the morning following mating (0.5 days postcoitum; dpc). Embryos were flushed from isolated oviducts at 1.5 dpc to recover 2-cell stage embryos. *In vivo* control blastocysts were recovered from uteri on day 3.5 following natural matings. Experiments were performed in compliance with guidelines set by the Canadian

Council for Animal Care, and the policies and procedures approved by the University of Western Ontario Council on Animal Care.

#### **4.2.2 Embryo Culture**

Embryos were flushed at the 2-cell stage, washed twice and cultured in Whitten's medium (made in-house) at a concentration 1 embryo per  $\mu\text{L}$  of medium in either 10, 15 or 20  $\mu\text{L}$  drops with filter-sterilized mineral oil overlay (Sigma). Embryos in the "Fast" group were those containing 8 or more cells and were transferred to new culture drops, while embryos in the "Slow" group contained less than 8 cells and were transferred to separate culture drops. On day 2 of culture, embryos were again separated at 3 PM +/- 1 hr. Embryos in the "Fast/Fast" (FF) group had begun cavitation, while those in the "Fast/Slow" (FS) group had not. Embryos in the "Slow/Fast" (SF) group had reached the compacted morula stage, while those in the "Slow/Slow" (SS) group had not yet compacted. All embryo groups were again transferred to new pre-equilibrated culture drops. Embryos were subjected to image analysis (below) then placed in individual tubes in approximately 1  $\mu\text{L}$  culture medium at noon on day 3 (107 hours after mid-point of light:dark cycle), snap frozen on dry ice and stored at  $-80^{\circ}\text{C}$ . Culture was performed at least 10 times, and embryos were analyzed from multiples litters.

#### **4.2.3 Imaging and Cell Counting**



On day 3 of embryo culture prior to freezing, embryos were transferred to culture drops containing Hoechst 33342. This dye was chosen as it binds in the minor groove of DNA and does not intercalate between the base pairs. Prior to experimental analysis, we determined that Hoechst 33342 staining had no effect on downstream methylation analyses of embryonic DNA (data not shown). Embryos were incubated in Hoechst 33342 for 7-10 minutes, and transferred to fresh drops of Whitten's medium for imaging. Images were obtained using Fluoview 1000 laser scanning confocal microscope (Olympus Corp), using the 20x objective (Olympus superapochromat 0.75), with a band pass of 425-475 nm for Hoescht. Z-stacks were taken for each embryo with a distance of 4  $\mu\text{m}$  between each slice. Bright field images were also taken of each embryo to facilitate downstream cell counting.

Cell counting was performed in duplicate from the top and from the bottom of each Z-stack using the Fluoview V10-ASW 2.1 Software. Embryo volume was calculated using 2 measurements of embryo length ( $\mu\text{m}$ ) taken in perpendicular planes using the Image Pro Analyzer 6.2. Software. These lengths were averaged and then divided by 2 to generate an average radius for each embryo. Volume of a sphere ( $V=4/3\pi r^3$ ) was used to calculate embryo volumes.

#### **4.2.4 Analysis of Imprinted Methylation and Expression**

Bisulfite mutagenesis and imprinted expression analysis was performed as described previously (Market-Velker et al., 2010a; Market-Velker et al., 2010b), with

modifications to allow the concurrent analysis of imprinted methylation and expression. Briefly, stored embryos were quickly thawed on ice, and 10  $\mu$ L of Dynabead Lysis Buffer was added to each tube. This solution was transferred to pre-equilibrated oligo-dT Dynabeads (Invitrogen) and incubated for 5 minutes at room temperature with shaking. Supernatant was transferred back to the original embryo tubes for bisulfite mutagenesis as previously described (Market-Velker et al., 2010a). mRNA-Dynabead complexes were processed and a cDNA library was generated as previously described (Market-Velker et al., 2010b). Analysis of imprinted expression of *H19* and *Snrpn* was performed using the LightCycler Real Time PCR System (Roche Molecular Biochemicals) as previously described (Market-Velker et al., 2010b).

Following bisulfite mutagenesis, nested PCR, cloning and sequencing was performed for *H19* and *Snrpn* ICR as previously described (Market-Velker et al., 2010b). Forty-50 clones per embryo were sequenced. Each sequence was analyzed for location and number of converted and unconverted non-CpG associated cytosines to obtain conversion rates (number of converted non-CpG cytosines/total number of non-CpG cytosines) as well as total number and location of CpG associated cytosines. Sequences with less than 85% conversion rates were not included. Identical clones (identical location and number of unconverted CpG associated cytosines, and identical location and number of unconverted non-CpG associated cytosines) were included only once. Polymorphisms present between B6 and CAST sequences at each gene analyzed allowed discrimination between parental alleles. Hypermethylation of a DNA strand was defined at >50% methylated CpGs on a given strand.

#### **4.2.5 Sex Determination in Individual Embryos**

The cDNA library generated for each embryo was used for the analysis of embryo sex. Two PCR reactions were performed for each embryo. The first, a nested PCR for the *Sry* gene, located on the Y chromosome, and second, amplification of *Xist*, a gene located on the X chromosome (Table 4.1). Samples were visualized with gel electrophoresis on a 12% acrylamide gel. The presence of an *Sry* and *Xist* amplicon indicated a male embryo, while amplification of *Xist* alone indicated a female embryo. Nested PCR for *Sry* was performed in duplicate.

#### **4.2.6 *Cdkn1c* Imprinted Expression Analysis**

The analysis of imprinted *Cdkn1c* expression was performed using the cDNA library generated for each embryo. PCR primers and parameters can be found in Table 4.1. Amplification was tested using SYBR green to allow determination of the range of cycles located in log-phase amplification. PCR on subsequent embryos was performed to ensure that amplification was log-phase upon completion of the PCR program. Following amplification embryos were digested with the TaqI restriction enzyme to determine

**Table 4.1: Primers and PCR Protocols**

<i>Gene</i>	<i>Primers</i>	<i>PCR Program</i>
<i>Xist</i>	Forward: 5' - TTG CGG GAT TCG CCT TGAT T - 3' Reverse: 5' - TGA GCA GCC CTT AAA GCC AC - 3'	95°C 2 min 95°C 15 sec 60°C 10 sec 72°C 20 sec 45 cycles 72°C 5 min
<i>Sry</i>	First round: Forward: 5' - GTG TGG TCC CGT GGT GAG AG - 3' Reverse: 5' - TCC AGT CTT GCC TGT ATG TGA TG - 3' Second Round: Forward: 5' - CCC AGC AGA ATC CCA GCA T - 3' Reverse: 5' - CTG TGA CAC TTT AGC CCT CCG - 3'	First round: 94°C 2 min 94°C 30 sec 60°C 30 sec 72°C 40 sec 45 cycles 72°C 5 min Second round: 95°C 2 min 94°C 20 sec 62°C 20 sec 72°C 30 sec 40 cycles 72°C 5 min
<i>Cdkn1c</i>	Forward: 5' - GCC AAT GCG AAC GAC TTC - 3' Reverse: 5' - TAC ACC TTG GGA CCA GCG TAC TCC - 3'	94°C 2 min 94°C 30 sec 58°C 30 sec 72°C 45 sec 40 cycles 72°C 5 min
<i>Atp1a1</i>	Forward: 5' - TTC AGC CCA GAA GGA CGA CAT G - 3' Reverse: 5' - AGG GAA GCC GTA GTA TCC GCC CA - 3'	2 <sup>nd</sup> Strand Synthesis: 94°C 2 min 94 °C 30 sec 56 °C/57 °C ( <i>Slc2a1</i> ) 30 sec 72 °C 30 sec 94°C 10 min
<i>Slc2a1</i>	Forward: 5' - CCC AGA AGG TTA TTG AGG AGT T - 3' Reverse: 5' - ACG CTT TGG TCT CTC TCC G - 3'	qRT-PCR: 95°C 4 min 94°C 30 sec 56°C / 57°C ( <i>Slc2a1</i> ) 30 sec
<i>Mapk14</i>	Forward: 5' - AGG CCA TGG TGC ATG TGT GT - 3' Reverse: 5' - AGT AGC TGG AGG AGG AGG AG - 3'	72°C 30 sec 45 cycles 94°C 2 min 30°C 2 min Melting curve from 55 - 95 °C, read every 1°C.
<i>Mrpl1</i>	Forward: 5' - TTG GAT ATG CCA AGT GAC CA - 3' Reverse: 5' - GCT TCT GCC GTT TGA GTT TC - 3'	

allelic identity; only the B6 allele is cleaved. Densitometry was performed using the Opticon Monitor Software (Biorad).

#### **4.2.7 Expression Analysis of *Atp1a1*, *Slc2a1* and *Mapk14***

The evaluation of *Atp1a1*, *Slc2a1* and *Mapk14* expression was performed using the cDNA library generated for each embryo, with mitochondrial ribosomal protein L1 (*Mrpl1*) as the internal control. Primers and PCR parameters can be found in Table 4.1. Second strand synthesis was performed using the forward primers of both *Mrpl1* and the gene of interest, and amplification products were then split into separate reactions for RT-PCR for *Mrpl1* and the gene of interest. Amplification was performed on biological replicates with SYBR green using the BioRad Opticon Monitor Real Time PCR Machine and Software. Analysis of RT-PCR was performed using the  $\Delta\Delta C_t$  method, with the GeneEx (BioRad) software.

#### **4.2.8 Statistical Analysis**

To compare between the four culture groups, and between cultured and *in vivo*-derived embryos, a nested two-factor ANOVA was performed using R (The R Foundation for Statistical Computing (Team, 2011)). The five groups of embryos were compared with respect to embryo volume; cell number; embryo sex; *H19* and *Snrpn* methylation levels; *H19*, *Snrpn* and *Cdkn1c* imprinted expression; and *Atp1a1*, *Slc2a1* and *Mapk14* expression using the “aov” (analysis of variance) command. Expression of the three

metabolic marker genes was normalized for *Mrp11* expression, and analyzed both before and after normalization for cell numbers. This was done to obtain additional information about whether the change in expression was attributed to an overall change in expression, or a change in levels of expression per cell, respectively. The effect size of each comparison that generated a significant p-value was estimated using the “lm” (linear model) function, setting the intercept of the model at zero. This was used to determine which groups were most similar to *in vivo*-derived embryos. A p-value less than 0.05 was taken to be statistically significant.

## **4.3 Results**

### **4.3.1 Effects of Embryo Culture on Blastocyst Cell Number and Volume**

The aim of our study was to determine whether any correlation existed between rates of preimplantation embryo development and loss of genomic imprinting. To best evaluate these effects, experiments were done at the individual embryo level, as we previously reported significant inter-embryo variability in response to ARTs (Market-Velker et al., 2010a; Market-Velker et al., 2010b) and because this is the level of importance in the human ART clinic. As such, we have developed a novel method to evaluate both imprinted methylation and expression of multiple loci in the same individual blastocyst, as well as obtain data about cell numbers, embryo volume, and embryo sex. This is the first study of its kind to evaluate multiple parameters to correlate morphological changes with epigenetic changes at the individual embryo level.

On the premise that individual embryos develop at different rates in culture, embryos were separated into four groups based on their stage of development at two pre-determined time points during the culture time course (Figure 4.1A). These time points were chosen based on the ability to reproducibly distinguish between “Fast” and “Slow” at each separation. Whitten’s culture medium was used as we determined from previous studies that culture in Whitten’s medium produced the most significant perturbations of genomic imprinting (Market-Velker et al., 2010b), and it allowed us to obtain sufficient embryo numbers in each group for analysis. Multiple culture time courses were completed and a total of 68 embryos were collected for analysis, 24 FF, 10 FS, 19 SF, and 15 SS. Of these embryos, 47 (16 FF, 9 FS, 10 SF and 12 SS) were analyzed for each of the following parameters: cell counts, embryo volume, embryo sex, imprinted methylation and expression of *H19* and *Snrpn*, and imprinted expression of *Cdkn1c* (Figure 4.1B). For the SS group nearly 40% of embryos arrested and did not reach the blastocyst stage (unpublished data). For all groups only embryos that developed to the blastocyst stage were analyzed.

To determine whether differences existed in the total cell numbers present in each of the four culture groups, embryos were stained with Hoechst 33342, Z-stacks were taken using confocal microscopy, and cells were counted (Figure 4.1B, 4.2A). We observed that on average the FF group contained 74.3 cells, the FS group 46.8 cells, the SF group 33.9 cells, the SS group 25.0, and the *in vivo*-derived group 28.3 cells, which was similar to previous studies (Bowman and McLaren, 1970; Smith and McLaren, 1977). To evaluate whether differences in cell number were statistically different between

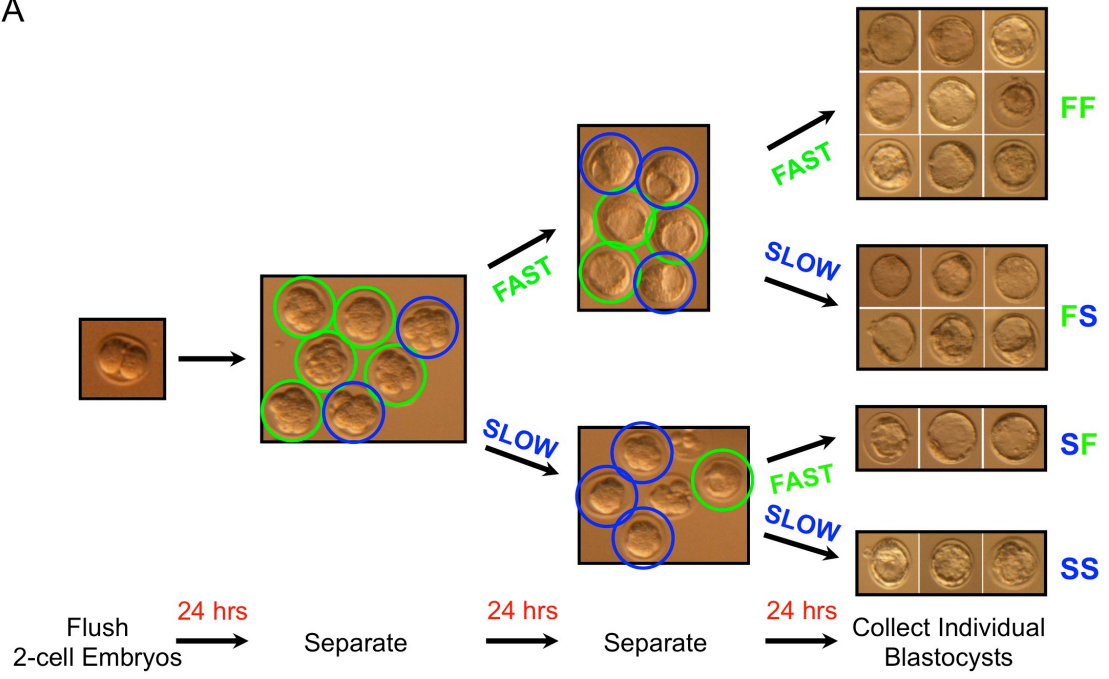
### Figure 4.1: Embryo Separation and Analysis

(A) Graphical representation of the embryo separation scheme. Two-cell embryos were collected, cultured for 24 hours, at which time the first separation took place. “Fast” embryos were those that displayed 8 or more cells, while “Slow” embryos were those containing less than 8 cells. After an additional 24 hours, the second separation was performed. From the original “Fast” group, those that showed a blastocyst cavity were classified as “Fast” in the second separation, while those with no evidence of a blastocyst cavity were classified as “Slow”. From the original “Slow” group, compacted morulae were classified as “Fast”, and those that were not compacted were classified as “Slow”. After an additional 24 hours, embryos were individually frozen at  $-80^{\circ}\text{C}$ .

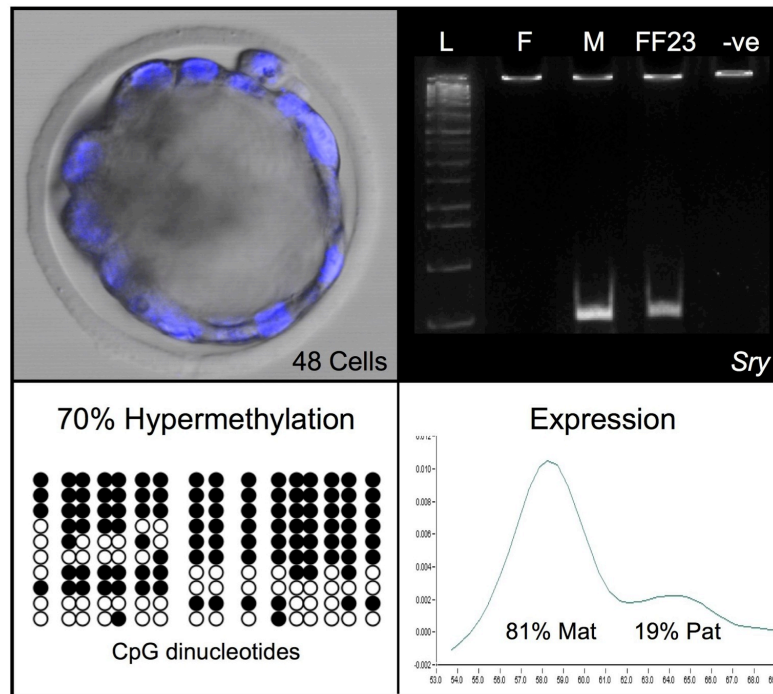
(B) Individual blastocyst assay for multiple data sets. Top left: Merge of bright field and Hoechst 33342 staining used to count cell numbers. Blastocyst FF23 contained 48 cells. Top right: *Sry* expression analysis used for embryo sex determination. L, ladder; F, Female control; M, Male control; FF23, blastocyst FF23; -ve, negative control. Blastocyst FF23 was a male embryo. Bottom left: Paternal *H19* methylation analysis. Filled circles represent methylated CpGs dinucleotides while unfilled circles represent unmethylated CpGs. Each row represents one DNA strand. Blastocyst FF23 displayed 70% hypermethylation at the *H19* paternal allele. Bottom right: LightCycler *H19* imprinted expression analysis. Blastocyst FF23 displayed biallelic expression of *H19*, with 81% and 19% expression from the maternal and paternal alleles, respectively.



A

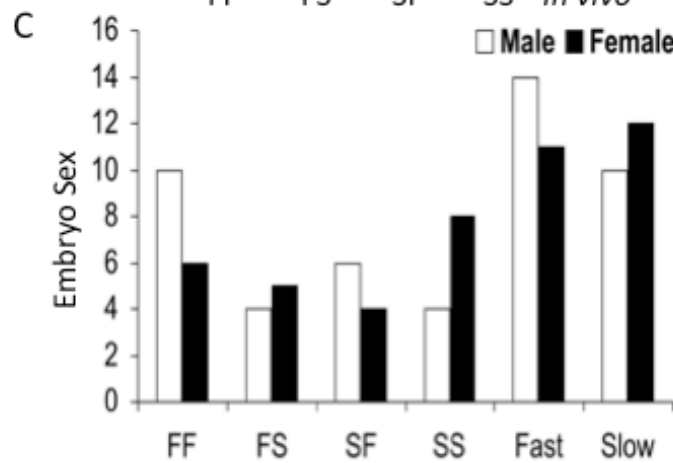
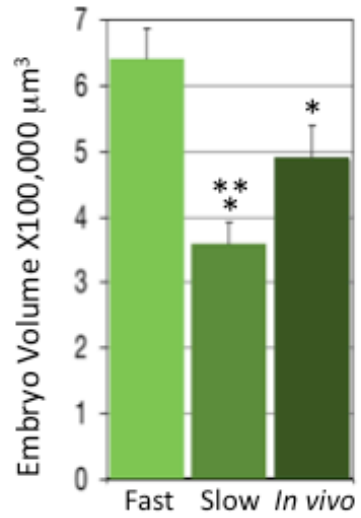
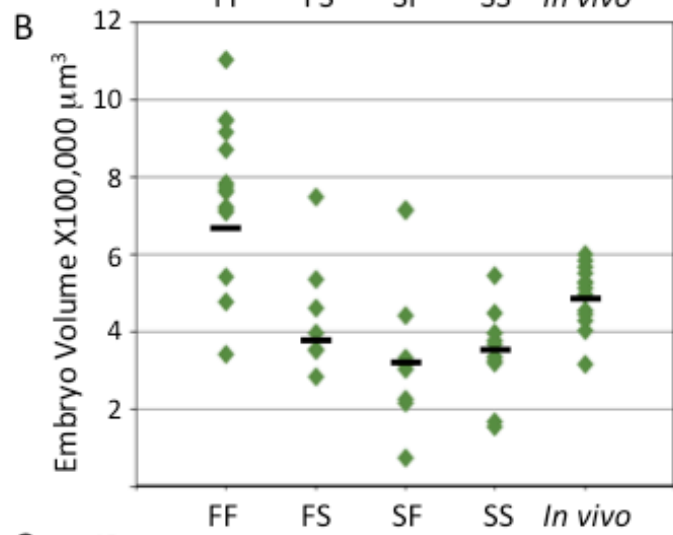
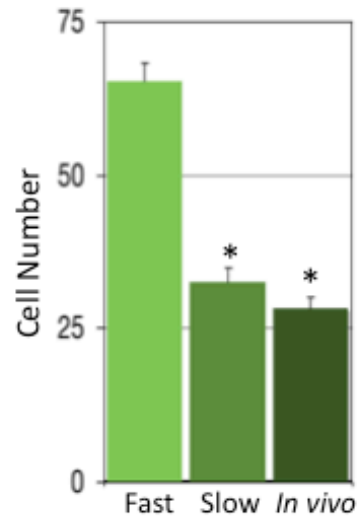
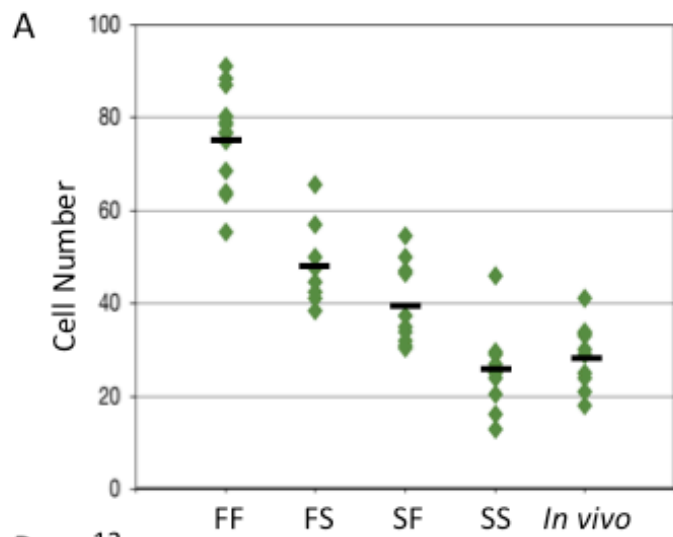


B



**Figure 4.2: Cell Numbers, Embryo Volume and Embryo Sex**

Graphical representation of cell numbers and embryo volumes of the four groups of cultured embryos and *in vivo*-derived embryos. (A) Left: Cell numbers separated by embryo group. Each diamond represents one embryo, and black bars indicate mean cell number of each group. Right: Mean cell numbers in “Fast” and “Slow” groups based on the first separation. \* the “Fast” group had significantly more cells than “Slow” group and the *in vivo*-derived group. (B) Left: Embryo volumes separated by embryo group. Black bars indicate mean embryo volume of each group. Right: Mean embryo volume in “Fast” and “Slow” groups based on the first separation. \* “Fast” embryos had significantly larger volumes than the “Slow” embryos and *in vivo*-derived embryos. \*\* “Slow” embryos displayed significantly fewer cells than *in vivo*-derived embryos. (C) Embryos separated by sex. White bars, male embryos; black bars, female embryos. Error bars represent standard errors of the mean.



the “Fast” (FF and FS) and “Slow” (SF and SS) groups at the first separation, and between groups (FF versus FS, and SF versus SS) in the second separation, we used a nested two-factor ANOVA. With respect to the first separation, the number of cells present in the “Fast” group was significantly greater than those in the “Slow” group. In addition, a statistically significant difference was observed at the second separation (Figure 4.2A). Therefore, not only were the “Fast” groups morphologically more advanced than the “Slow” groups as determined by embryo stage at the time of separation, but the cell cycle progressed more quickly in embryos in the “Fast” group compared to those in the “Slow” group as determined by cell numbers. *In vivo*-derived embryos contained significantly fewer cells than the “Fast” group, but failed to show a difference when compared to the “Slow” group. Therefore, from both statistical analysis and graphical representation (Figure 4.2A), we observed that the embryos clustered into three distinct groups. The FF group contained the most cells. The FS group contained fewer than the FF group. The SF, SS and *in vivo*-derived groups contained fewer cells than the FS group, but were indistinguishable from one another. Thus, the SF and SS groups most closely resembled the *in vivo*-derived group.

The total volume of each embryo was also calculated using measurements of length in two dimensions, determining the average of these lengths and using the formula for the volume of a sphere for calculations. Average volumes for the FF group was  $6.7 \times 10^5 \mu\text{m}^3$ , the FS group  $3.8 \times 10^5 \mu\text{m}^3$ , the SF group  $3.3 \times 10^5 \mu\text{m}^3$ , the SS group  $3.5 \times 10^5 \mu\text{m}^3$ , and *in vivo*-derived group  $4.9 \times 10^5 \mu\text{m}^3$  (Figure 4.2B). As before, a nested two-factor ANOVA was performed to test for differences between embryos in the first and

second separations. As with cell numbers, both groups at the first (FF and FS versus SF and SS) and second (FF versus FS, SF versus SS) separations displayed a significant difference in cell volume. *In vivo*-derived embryos displayed significantly smaller total embryo volume than the FF group, but a significantly larger embryo volume than the other three groups (Figure 4.2B). From the statistical analysis, the embryo volumes clustered into three separate groups. The FF embryos displayed the largest embryo volume, followed by *in vivo*-derived embryos, with the three remaining groups displaying smaller embryo volumes (FS, SF, SS were not significantly different from one another).

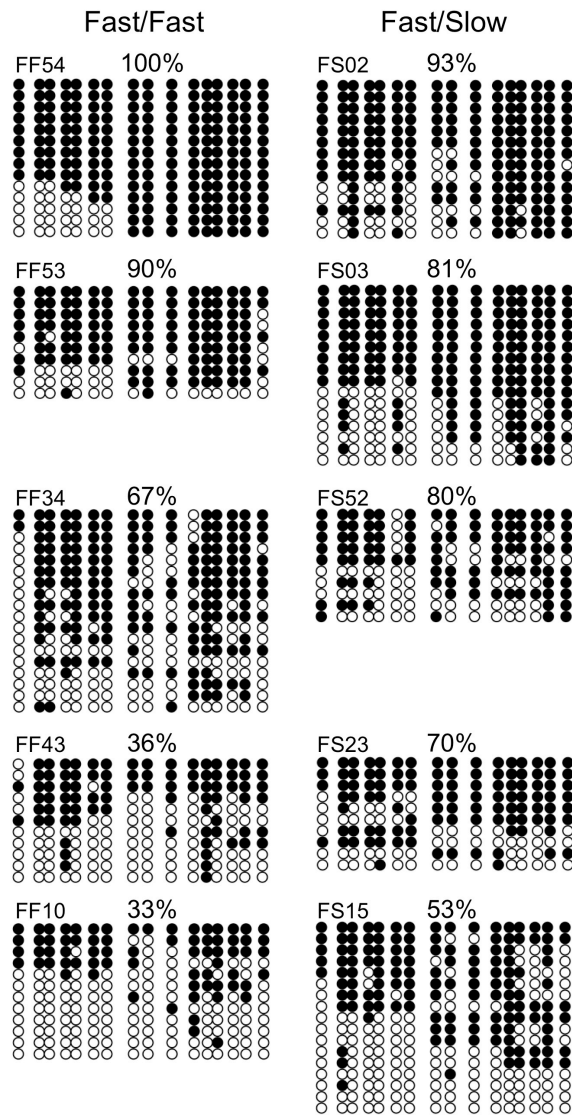
#### **4.3.2 Effects of Embryo Culture on Embryo Sex Ratios**

It has been suggested that male embryos develop faster than their female counterparts. Bovine (Avery et al., 1992) and ovine (Bernardi and Delouis, 1996) male embryos reach the blastocyst stage earlier than their female counterparts, with variations in the embryo culture type, and protocol affecting sex ratios (Pegoraro et al., 1998; Gutierrez-Adan et al., 2001; Iwata et al., 2008). In the mouse, the data are more contradictory. While some studies reported male to female sex ratio differences (Valdivia et al., 1993; Peippo and Bredbacka, 1995), another study reported no difference in embryo sex ratios (Byrne et al., 2006). For human embryos, some studies suggested that male embryos contain a greater number of cells than their female counterparts after IVF (Ray et al., 1995) while others report that this increase in cell number occurs with ICSI and not with IVF alone (Dumoulin et al., 2005), or vice versa (Dean et al., 2010). Moreover, an increase in the number of male offspring was noted following blastocyst

stage transfer, (Milki et al., 2003; Luna et al., 2007; Chang et al., 2009), while other groups have shown no sex differences in rates of development (Kausche et al., 2001; Richter et al., 2006; Csokmay et al., 2009; Weston et al., 2009). In light of the above studies, the possibility existed that rates of development were unrelated to adverse effects of culture but instead were the result of embryo sex. To address this potential bias, a nested PCR was performed for *Sry*, which is only present in male embryos, while *Xist*, located on the X chromosome, was used as a PCR control and was detected in both male and female embryos (Figure 4.1B). While we did observe more male embryos in the overall FF group (10 male, 6 female), and more female embryos in the SS group (6 males, 8 females), this result was not statistically significant (Figure 4.2C). Thus, different developmental rates were unrelated to embryo sex in our study. Furthermore, no correlation was found between embryo sex and the other parameters examined in this study.

#### **4.3.3 Effects of Embryo Culture on *H19* and *Snrpn* Imprinting**

To test our hypothesis that slower developing embryos will possess greater imprinting defects, we evaluated the ability of embryos to maintain genomic imprinting by examining two key loci, *H19* and *Snrpn*, in the four groups of cultured embryos. From our previous study (Market-Velker et al., 2010a), we showed that imprinted hypermethylation on the *H19* paternal ICR in *in vivo*-derived embryos was around 80%. Embryos with hypermethylation levels below 80% were therefore considered to exhibit “loss of methylation”. At least five embryos from each group were analyzed. The FF



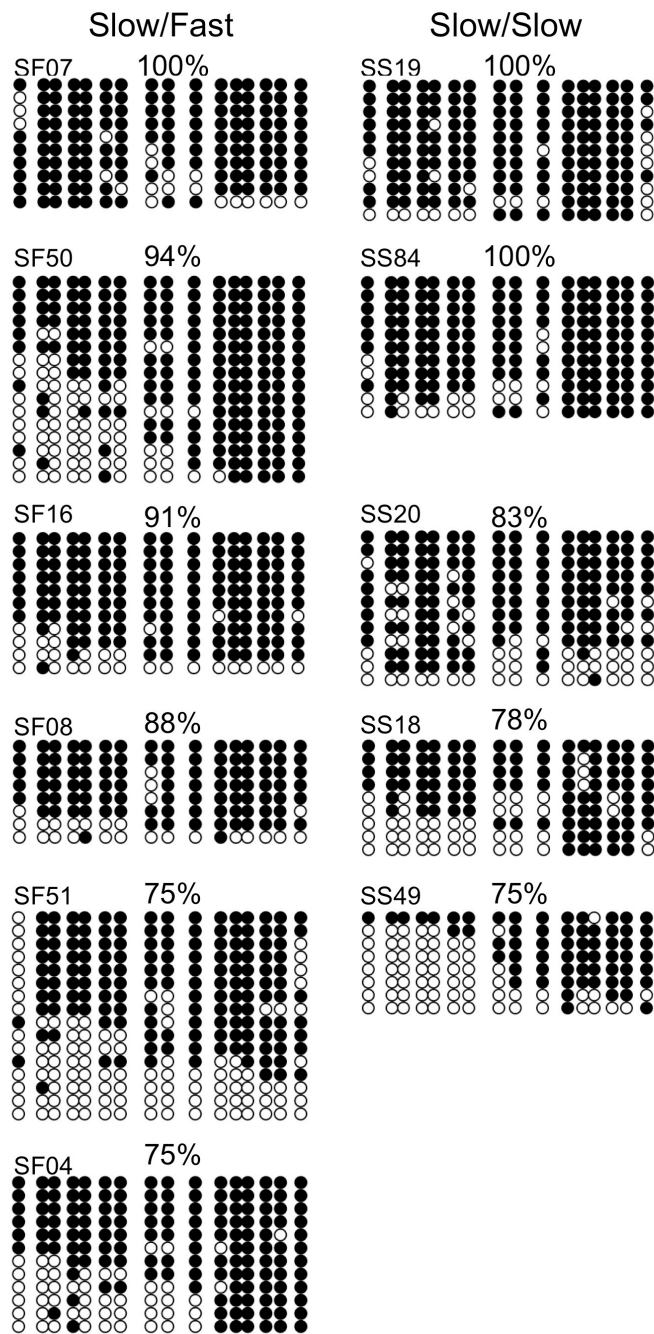
**Figure 4.3: Imprinted Methylation of *H19* in FF and FS Groups**

Imprinted methylation analysis of the paternal *H19* allele in “Fast/Fast” and “Fast/Slow” groups. Each group of circles represents one embryo, with the embryo name indicated in the top left. Percent hypermethylation indicated in the top middle. Each row represents one DNA strand. Filled circles represent methylated CpGs dinucleotides while unfilled circles represent unmethylated CpGs.

group displayed a loss of methylation in 3 of 5 embryos (hypermethylation levels 100%, 90%, 67%, 36% and 33%), with an average methylation of 65%, while the FS group displayed loss of methylation at only 2 of 5 embryos (hypermethylation levels 93%, 81%, 80%, 70% and 53%) with an average methylation of 75% (Figure 4.3). Two of six embryos in the SF group displayed loss of methylation (100%, 94%, 91%, 88%, 75%, and 75%), and 2 of 5 embryos in the SS group displayed loss of methylation (100%, 100%, 83%, 78%, and 75%) with an average methylation for both the SF and SS group of 87% (Figure 4.4). Therefore, the overall “Fast” groups displayed an average methylation of 71%, while the average of the “Slow” groups was much higher at 87%, a statistically significant difference ( $p < 0.05$ ) (Figure 4.5). In addition, while the “Fast” embryos displayed lower levels of methylation than *in vivo*-derived controls, no difference was observed between the “Slow” group and *in vivo*-derived embryos. This indicates that the slower developing embryos were better able to maintain *H19* imprinted methylation than their fast developing counterparts.

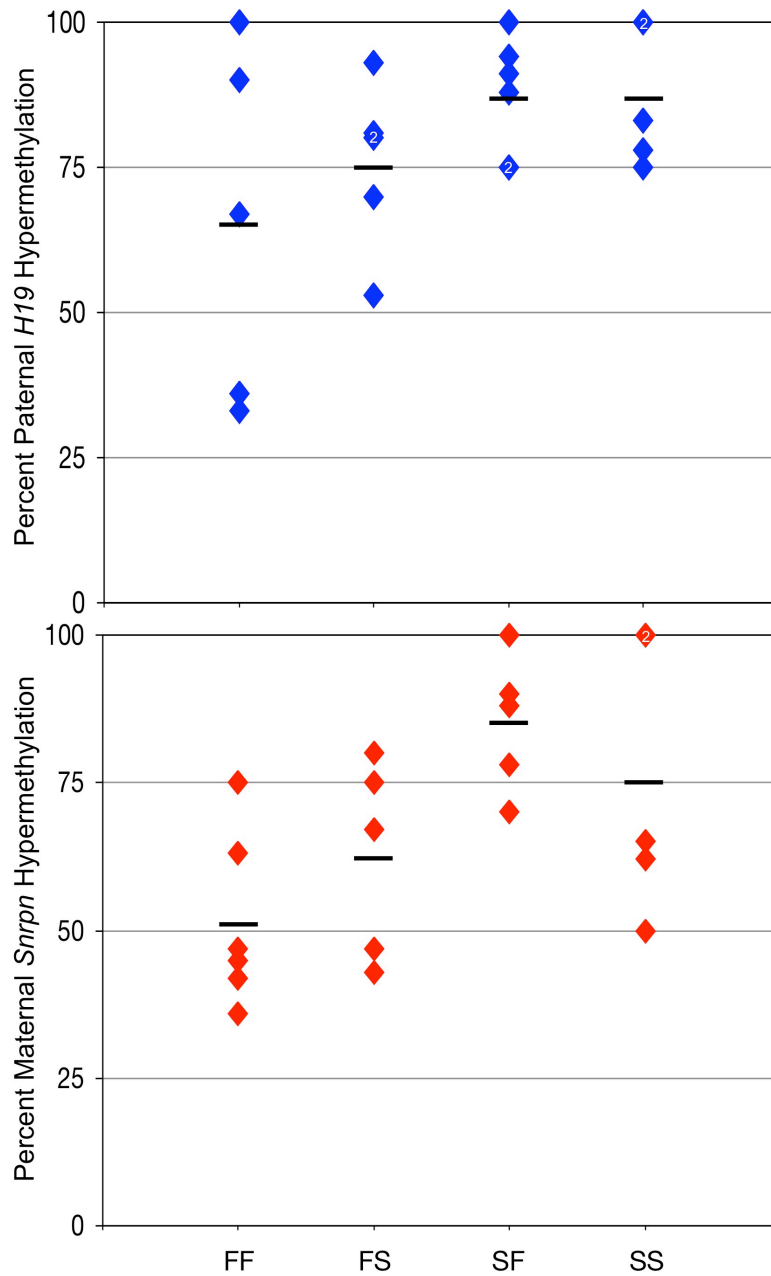
A similar result was also observed at the *Snrpn* ICR. From our previous study (Market-Velker et al., 2010a), we determined the threshold of methylation on the *Snrpn* maternal ICR to be 70% hypermethylation. The FF group displayed loss of methylation in 5 of 6 embryos (75%, 63%, 47%, 45%, 42%, and 36%) with an average methylation of 51%, and the FS group displayed a loss of methylation in 3 of 5 embryos (80%, 75%, 67%, 47%, and 43%) with an average methylation of 62% (Figure 4.6). The SF group displayed loss of methylation in 0 of the 5 embryos tested (100%, 90%, 88%, 78%, and 70%) with an average methylation of 85%, while the SS group displayed a loss of





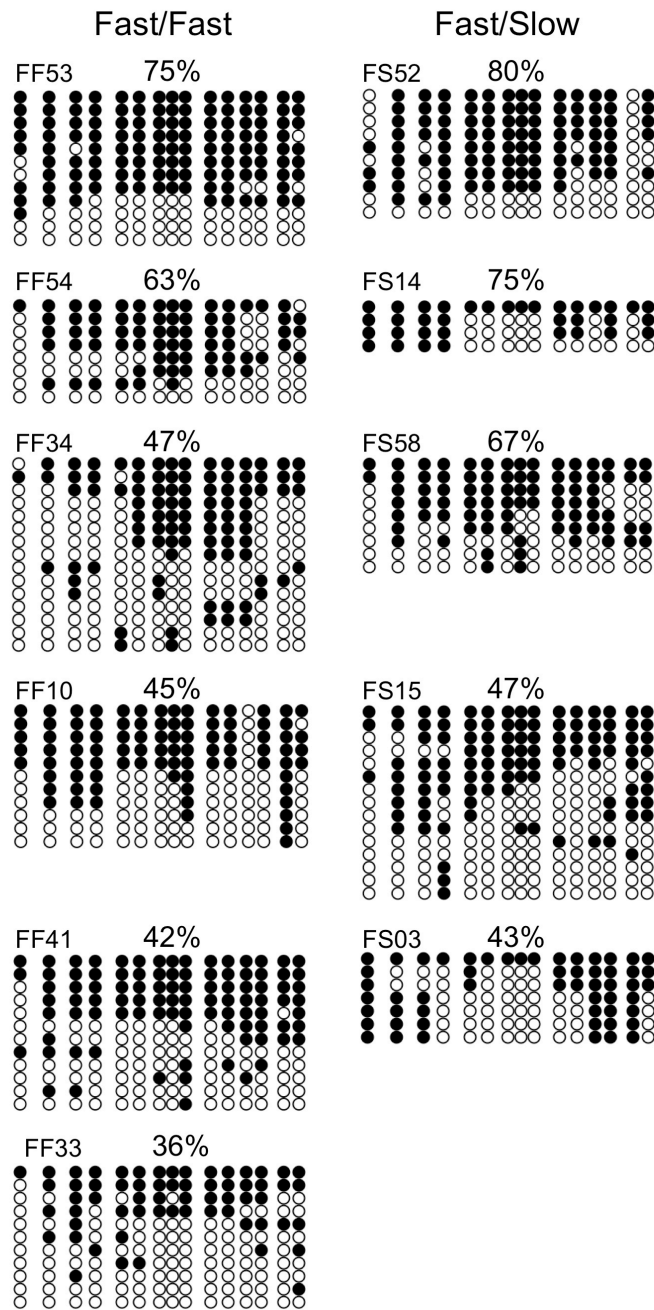
**Figure 4.4: Imprinted Methylation of *H19* in SF and SS Groups**

Imprinted methylation analysis of the paternal *H19* allele in "Slow/Fast" and "Slow/Slow" groups. See Figure 4.3 for details.



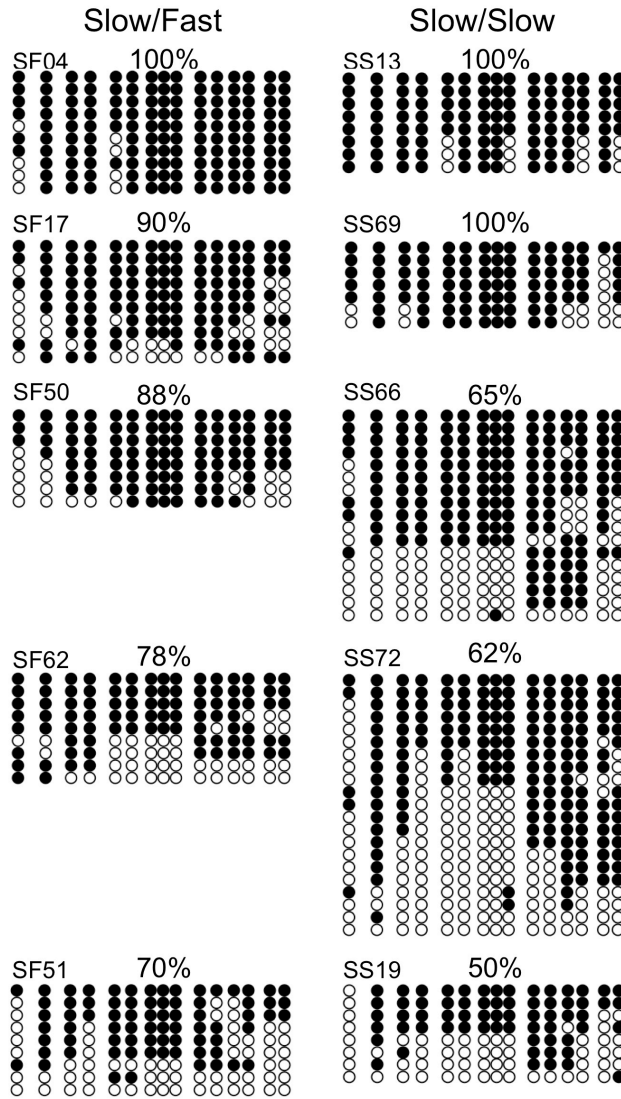
**Figure 4.5: Graphical Representation of Levels of *H19* and *Snrpn* Hypermethylation**

Top: Paternal *H19* hypermethylation levels. Bottom: Maternal *Snrpn* hypermethylation levels. Each diamond represents one embryo, and black bars represent mean hypermethylation levels in each group.



**Figure 4.6: Imprinted Methylation of *Snrpn* in FF and FS Groups**

Imprinted methylation of the maternal *Snrpn* allele in “Fast/Fast” and “Fast/Slow” groups. See Figure 4.3 for details.

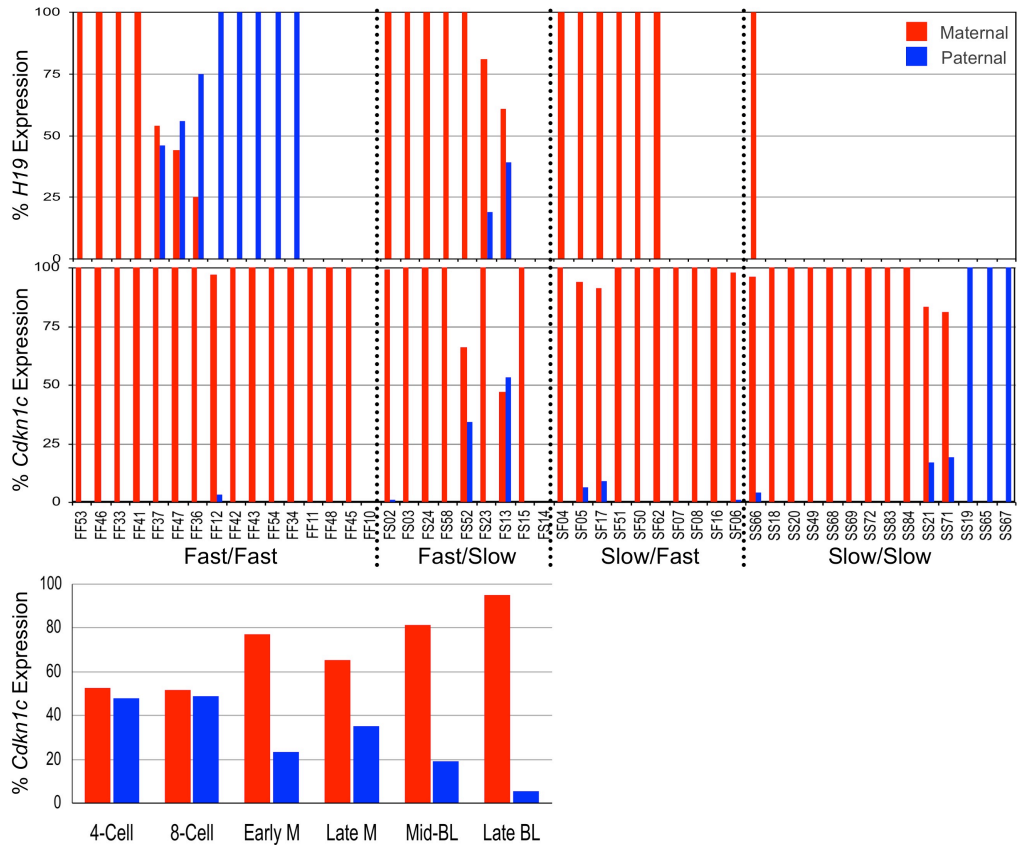


**Figure 4.7: Imprinted Methylation of *Snrpn* in SF and SS Groups**

Imprinted methylation of the maternal *Snrpn* allele in “Slow/Fast” and “Slow/Slow” groups. See Figure 4.3 for details.

methylation at 3 of the 5 embryos (100%, 100%, 65%, 62%, and 50%) with an average methylation of 75% (Figure 4.7). Overall, “Slow” embryos (SF and SS) displayed higher levels of methylation than the “Fast” group (FF and FS) ( $p < 0.05$ ). No difference was observed at the second separation. Thus, the “Slow” group was best able to maintain imprinted methylation.

Next, we analyzed *H19* and *Snrpn* imprinted expression in the *in vitro* cultured and *in vivo*-derived embryos. From our previous study, we have shown that in our mouse model *H19* is expressed from only a small number of *in vivo*-derived blastocysts (approximately 1 in 9) (Market-Velker et al, 2010b). For embryos displaying *H19* expression, this expression was solely from the maternal allele. Analysis of imprinted *H19* expression revealed that 12 out of 16 embryos exhibited *H19* expression in the FF group with only 4 of these embryos maintaining monoallelic *H19* expression from the maternal CAST allele (Figure 4.8). In addition, a significant number of embryos in the FF group displayed a “switched” expression pattern, where monoallelic expression occurred erroneously from the paternal allele. This was improved in the FS group, where 7 of 9 embryos exhibited *H19* expression with 5 maintaining imprinted expression, and further improved in the SF group, where all embryos displaying *H19* expression (6 of 10) did so exclusively from the maternal allele. *H19* expression in the SS group was most similar to *in vivo*-derived controls, with 1 of 12 embryos displaying *H19* expression, with the sole embryo expressing *H19* exclusively from the maternal CAST allele. Overall, “Fast” embryos from the first separation expressed *H19* in significantly more embryos than the “Slow” group. No difference was observed at the second separation for FF



**Figure 4.8: *H19*, *Snrpn* and *Cdkn1c* Imprinted Expression**

Imprinted Expression in the four groups of cultured embryos. Red bars indicate percent expression from the maternal allele, and blue bars indicate percent expression from the paternal allele. Top: *H19* imprinted expression analysis. Middle: *Cdkn1c* imprinted expression analysis. Embryo names are indicated on the X-axis.

Bottom: Developmental *Cdkn1c* imprinted expression in *in vivo*-derived embryos.

Embryo stage indicated on the X-axis. 4-cell, n=2, 12 pooled embryos each; 8-cell, n=2, 6 pooled embryos each; Early M, early morula, n=2, 3 pooled embryos each; Late M, late morula, n=2, 1 embryo each; Mid-BL, mid blastocyst; n=7, 1 embryo each; Late BL, late blastocyst; n=3, 1 embryo each.

versus FS groups. However, within the slow group, more embryos in the SF group expressed *H19* than the SS group. Furthermore, as with imprinted *H19* methylation, the overall “Fast” embryos showed a significantly greater loss of imprinted *H19* expression than “Slow” and *in vivo*-derived embryos. By comparison, “Slow” embryos were more similar to *in vivo*-derived controls at maintaining imprinted *H19* expression. FF embryos showed significantly greater loss of imprinted *H19* expression compared with the other groups. Similar to previous experiments (Mann et al., 2004; Market-Velker et al., 2010b), no effect on *Snrpn* imprinted expression was observed; all embryos displayed paternal-specific *Snrpn* expression (data not shown).

#### **4.3.4 Effects of Embryo Culture on *Cdkn1c* Imprinted Expression**

We predicted that embryos with biallelic *Cdkn1c* expression would exhibit slower rates of preimplantation development. To assess this, imprinted *Cdkn1c* expression was evaluated in the four groups of cultured embryos (Figure 4.8), as well as in *in vivo*-derived controls. All embryos in the FF group showed monoallelic expression, except one embryo, which lacked *Cdkn1c* expression. Two embryos in the FS group expressed *Cdkn1c* from both the parental alleles, while no embryos exhibited biallelic expression in the SF group. Two embryos in the SS group displayed biallelic expression, and three embryos showed *Cdkn1c* expression exclusively from the normally-silent paternal allele. Overall, no significant difference in imprinted expression was observed at the first separation between “Fast” and “Slow” groups. However, a significantly greater number of “Slow” embryos from the second separation, FS and SS, displayed biallelic *Cdkn1c*

expression compared with the “Fast” FF and SF groups, which were not statistically different from *in vivo*-derived controls. This result appeared contradictory to the *H19* imprinted expression pattern, leading us to question whether the observed data were related to developmental regulation of imprinted *Cdkn1c* expression rather than misregulation of *Cdkn1c* imprinting. As the time course of *Cdkn1c* imprinted expression had not been fully elucidated in preimplantation embryo stages, we evaluated imprinted *Cdkn1c* expression in pools of 4-cell, 8-cell and early morula, as well as individual late morula, and blastocyst stage embryos. Over this developmental time course, we observed an overall decrease in B6 expression, with 4- and 8-cell embryos displaying nearly equal levels of maternal and paternal expression, and late blastocysts displaying expression exclusively from the maternal allele. This data indicate that cultured embryos in the FS and SS groups displaying biallelic *Cdkn1c* expression were developmentally delayed compared with embryos in the FF and SF groups.

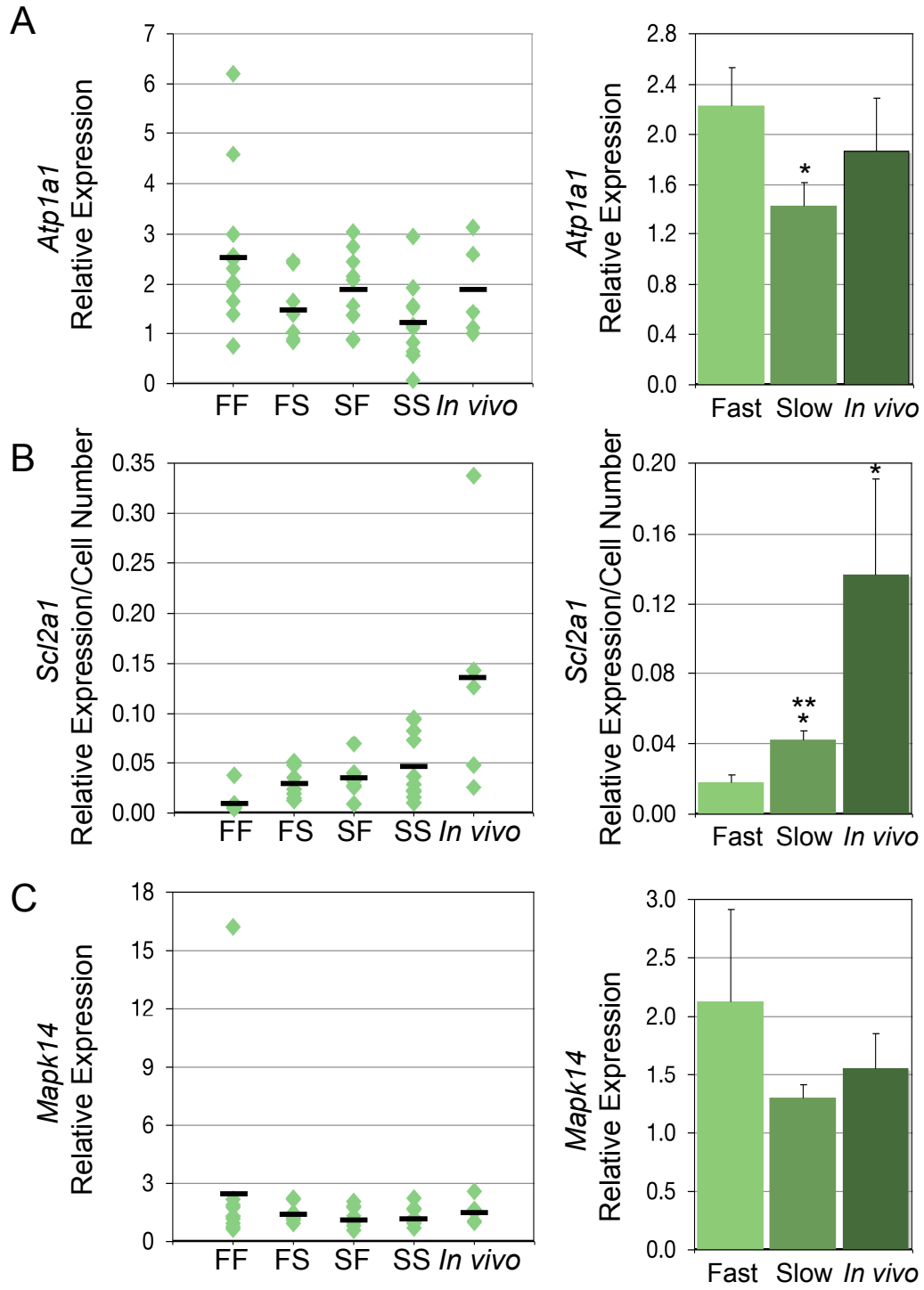
#### **4.3.5 Effects of Embryo Culture on Metabolic Marker Expression**

According to Leese’s “quiet embryo” theory, embryos more affected by suboptimal environment will compensate by increasing their metabolic activity (Leese, 2002). We hypothesized that embryos that develop faster and display a more frequent loss of imprinting will also show an increase in metabolic activity. To evaluate this hypothesis, we examined expression of three genes involved in early embryo metabolism: *Atp1a1* encoding the alpha subunit of the Na<sup>+</sup>/K<sup>+</sup> ATPase, *Slc2a1* encoding the solute carrier family 2, and *Mapk14* encoding *p38* alpha in 11 FF, 9 FS, 10 SF and 11 SS



#### Figure 4.9: Expression of Genes Involved in Embryo Metabolism

Relative expression of genes involved in embryo metabolism in cultured and *in vivo*-derived embryos. (A): Left panel: Relative *Atp1a1* expression in the four groups of cultured embryos and *in vivo*-derived embryos. Embryo group is indicated on the X-axis, each diamond represents one embryo, and black bars represent the mean relative expression in each group. Right panel: Mean relative *Atp1a1* expression in “Fast” and “Slow” groups based on the first separation. \* “Fast” embryos displayed significantly higher *Atp1a1* expression levels than “Slow” embryos. (B): Left panel: Relative *Slc2a1* expression corrected for cell numbers in the four groups of cultured embryos and *in vivo*-derived embryos. Black bars represent the mean relative expression corrected for cell numbers in each group. Right panel: Mean relative *Slc2a1* expression, corrected for cell numbers, in “Fast” and “Slow” groups based on the first separation. \* “Fast” embryos displayed significantly lower *Slc2a1* expression levels than *in vivo*-derived and “Slow” embryos, and \*\* “Slow” embryos displayed significantly lower *Slc2a1* expression levels than *in vivo*-derived embryos. (C) Left panel: Relative *Mapk14* expression in the four groups of cultured embryos and *in vivo*-derived embryos. Black bars represent the mean relative *Mapk14* expression in each group. Right panel: Mean relative *Mapk14* expression in “Fast” and “Slow” groups based on the first separation. No difference in mean relative *Mapk14* expression was observed between *in vivo*-derived, “Fast” and “Slow” embryos. Error bars represent standard errors of the mean.



blastocysts, as well as 5 *in vivo*-derived controls. *Atp1a1* expression was significantly higher in the “Fast” group than the “Slow” group at the first separation (Figure 4.9), while no significant difference was observed in mean levels of expression at the second separation, between either the FF and FS, or SF and SS groups. Moreover, a number of embryos within the FF group displayed very high expression, while a number of embryos within the SS group exhibited very low expression. Differences of large magnitudes in the response of individual embryos to the culture environment, in addition to an overall shift in the mean population response supports the idea that each embryo responds differently to environmental insult, and that “Fast” embryos are more likely to show abnormally high levels of expression than their “Slow” or *in vivo* counterparts.

Comparing *in vivo*-derived embryos to cultured embryos revealed three distinct groups. The FF group displayed significantly higher *Atp1a1* expression and the SS group significantly lower expression than the FS, SF and *in vivo*-derived embryos which displayed expression levels between the FF and SS groups. The FS, SF and *in vivo*-derived embryos were indistinguishable from one another. Normalization to cell numbers did not reveal any significant differences in expression between groups.

*Atp1a1* expression was also correlated with *H19* imprinted expression. As stated above, *in vivo*-derived embryos display one of two *H19* expression patterns, maternal or no expression. We compared *Atp1a1* expression levels between embryos displaying an *in vivo* pattern of *H19* expression (maternal CAST or no expression; 32 embryos) to those displaying an abnormal pattern (biallelic or abnormal B6 paternal expression; 7 embryos). Significantly, embryos with abnormal *H19* imprinted expression possessed higher *Atp1a1*

expression levels (2.7 +/-0.4) than those displaying an *in vivo* pattern of *H19* expression (1.6 +/-0.2). Thus, we observed a relationship between *Atp1a1* expression levels and maintenance of *H19* imprinted expression.

*Slc2a1* and *Mapk14* expression were also evaluated in these same embryos. The “Slow” group displayed significantly higher levels of *Slc2a1* expression than the “Fast” group at the first separation (Figure 4.9), following normalization for cell numbers. No difference was observed at the second separation. *In vivo*-derived embryos displayed significantly higher expression levels than all four cultured groups, both before and after correction for cell number. Overall, the *Slc2a1* expression analysis revealed three distinct groups, the FF group with the lowest expression, the FS, SF and SS groups with mid-level expression that was indistinguishable from one another, and *in vivo*-derived embryos with the highest *Slc2a1* expression. Strikingly, a difference in the dispersion of the samples in the five groups is noted, with a decrease in sample variability from *in vivo* to SS group, and further on to FF group, suggestive of a “dose” response. No relationship was observed between *Slc2a1* expression and *H19* imprinted expression. For *Mapk14*, while expression levels were higher in the FF compared with in the other culture groups and *in vivo* controls, this difference was not statistically significant. As well, no difference between groups after cell number correction, and no relationship to *H19* imprinted expression was observed.

#### **4.4 Discussion**

In this study, we set out to determine whether embryos with different developmental rates differed in their ability to maintain genomic imprinting, with slower rates of embryonic development correlating with loss of imprinting. Notably, we identified a subset of *in vitro* cultured embryos that, according to all parameters evaluated in this study, are very similar to *in vivo*-derived embryos (Figure 4.10). However, contrary to our expectation, we observed that embryos with faster developmental rates possessed greater cell numbers and embryo volume, as well as greater perturbations in genomic imprinting and metabolic marker expression. While the slowest developing embryos displayed lower cell numbers, smaller embryo volumes, and were better able to maintain genomic imprinting, a proportion of these embryos were developmentally delayed as determined by *Cdkn1c* imprinted expression and the presence of more arrested embryos prior to the blastocyst stage in this group. Instead, embryos with slow to moderate development rates (SF embryo group) were most similar to *in vivo*-derived embryos, displaying similar cell numbers, embryo volume, *H19* and *Snrpn* methylation, *H19* imprinted expression, and *Atp1a1* and *Slc2a1* expression.

#### **4.4.1 Relationship between Development Rates and Genomic Imprinting**

In this study, we evaluated the differences in the maintenance of genomic imprinting at two imprinted loci, *H19* and *Snrpn*, which are involved in the development of the imprinting disorders AS and BWS, and correlated this loss of imprinting with rates of preimplantation embryo development. Our data suggests that embryos that develop faster do so at the expense of maintaining epigenetic regulation. It is currently unclear

how embryo culture can lead to alterations in imprinting. One possibility is that culture conditions interfere with epigenetic maintenance mechanisms and this in turn deregulates the embryo's growth kinetics. Interestingly, embryos with only maternal genomes (parthenotes) or with only paternal genomes (androgenotes) display developmental defects that have been attributed to alterations in cell proliferation and differentiation rates (reviewed in Mann, 2005). We observed that faster developing embryos were more advanced morphologically, but had a shorter cell division cycle given the greater number of cells. On the other hand, slow embryos maintained rates of cell division similar to *in vivo*-derived embryos, given similar cell numbers. Given a possible relationship between genomic imprinting, developmental rates and cell cycle progression, we investigated the imprinted expression of *Cdkn1c*, a cell-cycle regulator that acts to inhibit cell cycle progression through its interaction with cyclin-CDK complexes (Lee et al., 1995). We demonstrated that *Cdkn1c* expression is biallelic in early cleavage stages, and becomes maternal-specific as preimplantation development progresses. Interestingly, we observed more embryos with biallelic expression in the "Slow" groups (FS and SS) at the second separation than those in the "Fast" groups (FF and SF), suggesting that *Cdkn1c* may play a role in regulating progression through the latter phase of preimplantation development. Lower levels of expression, in the form of monoallelic expression, may result in less cell cycle inhibition and in turn, increase the rate of cell division. Alternatively, biallelic expression may result in an increase in cell cycle inhibition, resulting in increased time required to progress through the cell cycle.

#### 4.4.2 Relationship Between Development Rates and Embryo Volume

During preimplantation development, the total volume of the embryo remains relatively constant, while the number of cells increase as development proceeds (Aiken et al., 2004). With respect to embryo volume, the effect size of the difference between FF and *in vivo*-derived embryos was larger than that between *in vivo* controls and the other three groups, again indicating that slower embryos were more similar to *in vivo*-derived controls. This raises the question as to what mechanisms could lead to a difference in embryo volume for the FF group. Two possible explanations for the differences observed in embryo volume between cultured and *in vivo*-derived controls are an increase in overall cell volume, or an increase in volume of the blastocoel cavity. An increase in cell volume may be due to increased transcription, translation and protein processing necessary to support higher metabolism in response to cell stress as well as changes in the cell's ability to regulate intracellular osmotic pressure (Baltz and Tartia, 2010). One mediator of environmental stress is MAPK14, which regulates embryonic adaptations to culture such as variations in culture medium osmolarity (Bradham and McClay, 2006; Fong et al., 2007; Bell et al., 2009). Treatment with MAPK14 inhibitors has demonstrated a requirement for MAPK14 in early cleavage division embryos (Natale et al., 2004). As larger FF embryos may respond to environmental stress via MAPK14 with the end result of producing larger cells, we investigated *Mapk14* expression in the five embryo groups. Our analysis showed no difference in *Mapk14* expression between the four culture groups and *in vivo* controls, indicating that variations in cell volume do not likely account for overall variations in blastocyst volume that we observed. MAPK14

levels and its posttranslationally-modified forms need to be investigated to confirm this observation.

Alternatively, larger FF embryo volumes may be a result of larger cavity volumes. Trophectoderm (TE) cells produce a blastocoel cavity through the use of the  $\text{Na}^+/\text{K}^+$  ATPase, which generates an ionic gradient across the trophectoderm, facilitating movement of water from the outside environment to the inside of the embryo (Watson and Barcroft, 2001; Barcroft et al., 2003). Embryos that contain more TE cells will have greater levels of the  $\text{Na}^+/\text{K}^+$  ATPase, resulting in a greater influx of water into the blastocoel cavity. This would result in faster production of a larger cavity and therefore a more morphologically advanced embryo. Our results favour the latter hypothesis, where an increase in TE cells generates a larger blastocoel cavity via increased  $\text{Na}^+/\text{K}^+$  ATPase. Examination of *Atp1a1* expression, the alpha subunit of the  $\text{Na}^+/\text{K}^+$  ATPase, revealed higher levels of expression in the “Fast” group when compared to the “Slow” group. In addition, as predicted by the above model, this increase in *Atp1a1* expression was a function of cell number, as no difference in expression was observed when corrected for cell number. Interestingly, we also observed that increased *Atp1a1* expression levels correlated with loss of *H19* imprinted expression. Thus, this provides a link between genomic imprinting and developmental rates.

#### **4.4.3 Relationship between Development Rates and Embryo Metabolism**

Changes in *Atp1a1* expression in the faster developing embryos suggest that the metabolism of these embryos is altered compared to *in vivo*-derived controls. To further



investigate this, we examined *Slc2a1* expression. SLC2A1 is one of the primary glucose transporters in the preimplantation embryo. In early cleavage division embryos, SLC2A1 is primarily localized to the nucleoli and nuclear membranes. Post-compaction, *Slc2a1* expression increases dramatically (Morita et al., 1994; Uechi et al., 1997) and SLC2A1 translocates to the basolateral membrane of TE cells and the plasma membrane of ICM cells (Pantaleon et al., 2001), permitting shuttling of glucose from the blastocoel cavity to ICM cells. This differential localization of SLC2A1 coincides with the switch of energy preferences in the developing embryo, from pre-compaction utilization of pyruvate to post-compaction utilization of glucose. Before the switch, a transient pulse of glucose is required. A complete absence of glucose during the early stages of preimplantation development results in delay or impaired development to the blastocyst stage (Martin and Leese, 1995; Pantaleon et al., 2008). Importantly, multiple groups have shown that *Slc2a1* mRNA expression and protein levels are significantly higher in *in vivo*-derived compared to *in vitro* cultured embryos (Morita et al., 1994; Uechi et al., 1997; Leppens-Luisier et al., 2001; Balasubramanian et al., 2007). In our study, we also found much higher levels of *Slc2a1* expression in *in vivo*-derived compared to cultured embryos. Interestingly, “Slow” embryos expressed *Slc2a1* at significantly higher levels than their “Fast” counterparts when corrected for cell number, again demonstrating that the “Slow” group is more similar to controls. No significant difference was observed at the second separation.

As both *Slc2a1* mRNA and protein levels increase at compaction in response to the increased need for glucose utilization, we hypothesize that the “Fast” embryos are

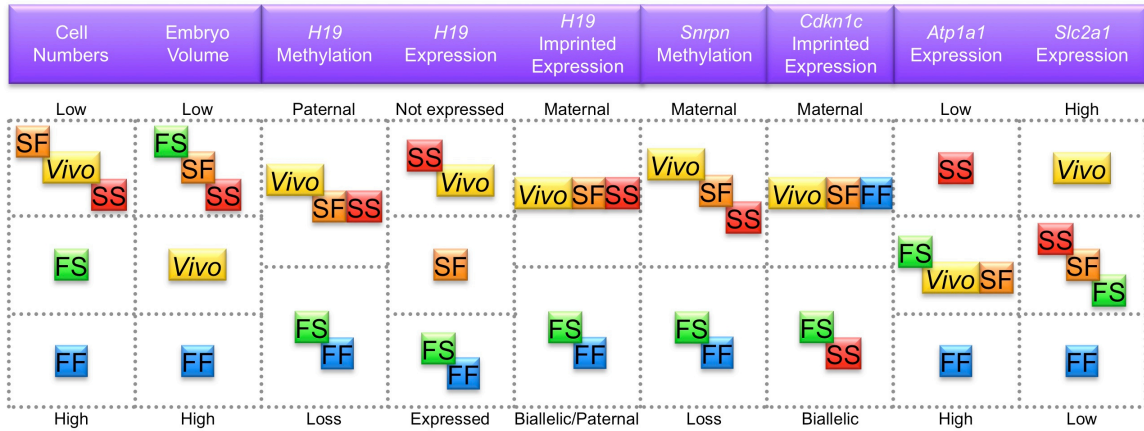
unable to adequately upregulate *Slc2a1*, while the “Slow” embryos respond appropriately and have levels of *Slc2a1* more similar to *in vivo*-derived embryos. In the “Fast” embryos, a lack of appropriate increase in *Slc2a1* expression would result in decreased availability of glucose. To maintain their intrinsic rates of development, and support blastocyst formation as well as all other cellular activities, these embryos would be required to switch their metabolism to utilize alternate means of ATP generation such as amino acid catabolism (for gluconeogenesis) and beta oxidation of fatty acids (Sturmeijer et al., 2009b). Interestingly, differential uptake of glucogenic and non-glucogenic amino acids has been noted between developmentally competent and incompetent embryos cultured *in vitro* (Houghton et al., 2002; Stokes et al., 2007; Lehninger et al., 2005). In addition, a large proportion of the ATP generated in the developing blastocyst is utilized by the Na<sup>+</sup>/K<sup>+</sup> ATPase, for which we demonstrated higher *Atp1a1* expression levels in “Fast” developing embryos (Leese et al., 2007), thereby further reducing the pool of ATP available for other cellular activities in these embryos. Persistent inadequate ATP generation, would lead to compromised cellular functions including epigenetic regulation of genomic imprinting (Hargreaves and Crabtree, 2011). Perhaps this is not surprising as all known chromatin-remodeling complexes are powered by an ATPase subunit (Hargreaves and Crabtree, 2011). Interestingly, we observed that increased *Atp1a1* expression levels correlated with loss of *H19* imprinted expression, lending support to the attractive idea that culture-induced epigenetic effects may act at the interface of a Na<sup>+</sup>/K<sup>+</sup> ATPase. This study provides a link between genomic imprinting, developmental rates and metabolism, with increased metabolism of alternate energy sources representing a

compensation for the maladaptation of the embryo to the suboptimal culture environment. Thus, future studies should be directed towards the analysis of ATP-driven metabolic factors and epigenetic regulators in “Fast” and “Slow” developing embryos over their period of development in culture.

Taken all together, our data indicate that “Slow” embryos maintain a baseline level of metabolic activity similar to *in vivo*-derived embryos, while “Fast” embryos adapt and compensate by increasing the activity of other metabolic pathways, compromising cellular processes to maintain continued embryo growth and survival. Moreover, imprinting defects in “Fast” embryos indicate altered epigenetic reprogramming in response to suboptimal embryo culture, while “Slow” developing embryos exhibit more *in vivo*-like reprogramming. Thus, our data lend support to the quiet embryo hypothesis espoused by Leese and colleagues. This hypothesis suggests that the most viable embryos are “quiet”, exhibiting lower levels of metabolic activity, expending less energy repairing damage caused by the suboptimal culture environment, and possessing slower cell division cycles (Leese, 2002; Baumann et al., 2007; Leese et al., 2007; Sturmey et al., 2009a). In contrast, embryos that actively adapt to culture will possess higher metabolic levels and faster cell cycle divisions. Our study is the first to demonstrate a link between embryo culture, development rates, imprint maintenance and metabolism.

#### **4.4.4 The Best Embryos for Transfer**

The term assisted reproductive technologies encompasses many techniques used to treat human infertility. However, all involve the manipulation of human gametes and preimplantation embryos, and many involve embryo culture during preimplantation development. While the optimal time and number of embryos to transfer after fertilization and culture has been a source of debate, all are in agreement that only the “best” or “healthiest” embryos should be transferred (Kallen et al., 2010; Min et al., 2010; Porat et al., 2010; Sills and Palermo, 2010; Wang et al., 2010). Many algorithms have attempted to determine the parameters that most accurately predict successful embryo transfer resulting in implantation and pregnancy (Elizur et al., 2005; Lesourd et al., 2006). Currently, morphological characteristics and stage of embryo development at a given time point are the most commonly used criteria for identifying “healthy” embryos that should be transferred to patients in IVF clinics (Shoukir et al., 1997; Van Montfoort et al., 2004). Multiple studies have suggested that those embryos attaining the 4-cell stage (cleavage-stage transfer) or the blastocyst stage (blastocyst transfer) the fastest are most suitable for embryo transfer (Claman et al., 1987; Windt et al., 2004; Biezinova et al., 2006; Wang et al., 2010). However, other studies have suggested that embryos progressing at a moderate pace are those that should be used, and have cautioned against the use of embryos with very fast or very slow development (Cummins et al., 1986; Alikani et al., 2000; Weitzman et al., 2010). It is important to know whether slower developing embryos are indeed suitable for transfer to patients, especially in situations where a choice between which embryo(s)



**Figure 4.10: Summary of Multiple Parameter Analysis at the Individual Embryo Level**

Dotted lines indicate significance. The FF group was most different from *in vivo* controls in all assays. Embryos in the “Slow” group (specifically SF) were more similar to *in vivo*-derived embryos.

to transfer can be made. Previously, the relevance of these criteria to the maintenance of genomic imprinting was unknown.

Results from this study support the transfer of embryos displaying slow to moderate rates of development. We argue that embryos in the SF group are most suitable for embryo transfer. These embryos displayed imprinted methylation and expression, cell numbers, embryo volume, and metabolic marker expression most similar and in some cases indistinguishable from *in vivo*-derived embryos (Figure 4.10). Our data also argue against transfer of the fastest developing embryos. The FF group was most different from *in vivo* controls in all assays, and most importantly, showed the highest number of embryos with loss of imprinted *H19* and *Snrpn* ICR methylation. While the FS group was more similar to controls than the FF group with respect to embryo volume and *H19* imprinted expression, this group still displayed lower levels of *H19* and *Snrpn* imprinted methylation, greater perturbations of *Cdkn1c* imprinted expression, greater expression of *Atp1a1* and lower expression of *Slc2a1* than controls. By comparison, the slowest (SS) group displayed levels indistinguishable from controls with respect to cell number, embryo volume, and *H19* imprinted expression. However, the SS group showed levels of *Cdkn1c* imprinted expression indicative of delayed development, and lower levels of *H19* and *Snrpn* imprinted methylation than *in vivo*-derived control embryos. In addition, 40% of embryos in the slowest (SS) group failed to develop to the blastocyst stage after 3 days of culture. As such, the SF group is likely the most suitable for embryo transfer in the human clinic.

Our group and others have previously reported that the response of preimplantation embryos to *in vitro* culture with respect to genomic imprinting is stochastic (Doherty et al., 2000; Mann et al., 2004; Market-Velker et al., 2010b; Lim et al., 2009; Rossignol et al., 2006). Here, we show that this can partly be attributed to a differential response of embryos to culture, with the fastest developing embryos acquiring the greatest perturbations in imprinted gene regulation and metabolic gene expression. We propose that embryos that undergo reprogramming to counter the stresses of suboptimal culture are the least healthy for embryo transfer. Therefore, selecting embryos with slow rates of development is one step towards choosing a more “healthy” embryo. Determining the differences between slowest, slow to moderate and fast developing embryos, and developing non-invasive methods to more easily identify them in the human clinic will be critical to choosing the “best” or “healthiest” embryos for transfer, thereby maximizing pregnancy rates.

## 4.5 References

- Aiken, C. E., Swoboda, P. P., Skepper, J. N. and Johnson, M. H. (2004) 'The direct measurement of embryonic volume and nucleo-cytoplasmic ratio during mouse pre-implantation development' *Reproduction* 128(5): 527-535.
- Alikani, M., Calderon, G., Tomkin, G., Garrisi, J., Kokot, M. and Cohen, J. (2000) 'Cleavage anomalies in early human embryos and survival after prolonged culture in-vitro', *Hum Reprod* 15(12): 2634-43.
- Augustin, R., Pocar, P., Navarrete-Santos, A., Wrenzycki, C., Gandolfi, F., Niemann, H. and Fischer, B. (2001) 'Glucose transporter expression is developmentally regulated in in vitro derived bovine preimplantation embryos', *Mol Reprod Dev* 60(3): 370-6.
- Avery, B., Jorgensen, C. B., Madison, V. and Greve, T. (1992) 'Morphological development and sex of bovine in vitro-fertilized embryos', *Mol Reprod Dev* 32(3): 265-70.
- Balasubramanian, S., Son, W. J., Kumar, B. M., Ock, S. A., Yoo, J. G., Im, G. S., Choe, S. Y. and Rho, G. J. (2007) 'Expression pattern of oxygen and stress-responsive gene transcripts at various developmental stages of in vitro and in vivo preimplantation bovine embryos', *Theriogenology* 68(2): 265-75.
- Barcroft, L. C., Offenberg, H., Thomsen, P. and Watson, A. J. (2003) 'Aquaporin proteins in murine trophectoderm mediate transepithelial water movements during cavitation', *Dev Biol* 256(2): 342-54.
- Barker, D. J. (2000) 'In utero programming of cardiovascular disease', *Theriogenology* 53(2): 555-74.
- Baumann, C. G., Morris, D. G., Sreenan, J. M. and Leese, H. J. (2007) 'The quiet embryo hypothesis: molecular characteristics favoring viability', *Mol Reprod Dev* 74(10): 1345-53.
- Bell, C. E., Lariviere, N. M., Watson, P. H. and Watson, A. J. (2009) 'Mitogen-activated protein kinase (MAPK) pathways mediate embryonic responses to culture medium osmolarity by regulating Aquaporin 3 and 9 expression and localization, as well as embryonic apoptosis', *Hum Reprod* 24(6): 1373-86.
- Bernardi, M. L. and Delouis, C. (1996) 'Sex-related differences in the developmental rate of in-vitro matured/in-vitro fertilized ovine embryos', *Hum Reprod* 11(3): 621-6.
- Biezinova, J., Svobodova, M., Oborna, I., Fingerova, H., Dosta, J. and Krskova, M. (2006) '[Embryo quality evaluation according to the speed of the first cleavage after conventional IVF]', *Ceska Gynekol* 71(2): 105-10.
- Biggers JD, and Summers MC. (2008) 'Choosing a culture medium: making informed choices', *Fertil Steril* 90(3):473-483.
- Boerjan, M. L., den Daas, J. H. and Dieleman, S. J. (2000) 'Embryonic origins of health: long-term effects of IVF in human and livestock', *Theriogenology* 53(2): 537-47.
- Bowman, P. and McLaren, A. (1970) 'Viability and growth of mouse embryos after in vitro culture and fusion', *J Embryol Exp Morphol* 23(3): 693-704.



- Bradham C. and McClay D. R. (2006), 'p38 MAPK in development and cancer', *Cell Cycle* 5(8): 824-828.
- Byrne, M. J., Newmark, J. A. and Warner, C. M. (2006) 'Analysis of the sex ratio in preimplantation embryos from B6.K1 and B6.K2 Ped gene congenic mice', *J Assist Reprod Genet* 23(7-8): 321-8.
- Chang, A. S., Moley, K. H., Wangler, M., Feinberg, A. P. and Debaun, M. R. (2005) 'Association between Beckwith-Wiedemann syndrome and assisted reproductive technology: a case series of 19 patients', *Fertil Steril* 83(2): 349-54.
- Chang, H. J., Lee, J. R., Jee, B. C., Suh, C. S. and Kim, S. H. (2009) 'Impact of blastocyst transfer on offspring sex ratio and the monozygotic twinning rate: a systematic review and meta-analysis', *Fertil Steril* 91(6): 2381-90.
- Claman, P., Armant, D. R., Seibel, M. M., Wang, T. A., Oskowitz, S. P. and Taymor, M. L. (1987) 'The impact of embryo quality and quantity on implantation and the establishment of viable pregnancies', *J In Vitro Fert Embryo Transf* 4(4): 218-22.
- Cox, G. F., Burger, J., Lip, V., Mau, U. A., Sperling, K., Wu, B. L. and Horsthemke, B. (2002) 'Intracytoplasmic sperm injection may increase the risk of imprinting defects', *Am J Hum Genet* 71(1): 162-4.
- Csokmay, J. M., Hill, M. J., Cioppettini, F. V., Miller, K. A., Scott, R. T., Jr. and Frattarelli, J. L. (2009) 'Live birth sex ratios are not influenced by blastocyst-stage embryo transfer', *Fertil Steril* 92(3): 913-7.
- Cummins, J. M., Breen, T. M., Harrison, K. L., Shaw, J. M., Wilson, L. M. and Hennessey, J. F. (1986) 'A formula for scoring human embryo growth rates in in vitro fertilization: its value in predicting pregnancy and in comparison with visual estimates of embryo quality', *J In Vitro Fert Embryo Transf* 3(5): 284-95.
- Dean, J. H., Chapman, M. G. and Sullivan, E. A. (2010) 'The effect on human sex ratio at birth by assisted reproductive technology (ART) procedures--an assessment of babies born following single embryo transfers, Australia and New Zealand, 2002-2006', *BJOG* 117(13): 1628-34.
- DeBaun, M. R., Niemitz, E. L. and Feinberg, A. P. (2003) 'Association of in vitro fertilization with Beckwith-Wiedemann syndrome and epigenetic alterations of LIT1 and H19', *Am J Hum Genet* 72(1): 156-60.
- Doherty, A. S., Mann, M. R., Tremblay, K. D., Bartolomei, M. S. and Schultz, R. M. (2000) 'Differential effects of culture on imprinted H19 expression in the preimplantation mouse embryo', *Biol Reprod* 62(6): 1526-35.
- Dumoulin, J. C., Derhaag, J. G., Bras, M., Van Montfoort, A. P., Kester, A. D., Evers, J. L., Geraedts, J. P. and Coonen, E. (2005) 'Growth rate of human preimplantation embryos is sex dependent after ICSI but not after IVF', *Hum Reprod* 20(2): 484-91.
- Ecker, D. J., Stein, P., Xu, Z., Williams, C. J., Kopf, G. S., Bilker, W. B., Abel, T. and Schultz, R. M. (2004) 'Long-term effects of culture of preimplantation mouse embryos on behavior', *Proc Natl Acad Sci U S A* 101(6): 1595-600.

- Elizur, S. E., Lerner-Geva, L., Levron, J., Shulman, A., Bider, D. and Dor, J. (2005) 'Factors predicting IVF treatment outcome: a multivariate analysis of 5310 cycles', *Reprod Biomed Online* 10(5): 645-9.
- Fernandez-Gonzalez, R., Moreira, P., Bilbao, A., Jimenez, A., Perez-Crespo, M., Ramirez, M. A., Rodriguez De Fonseca, F., Pintado, B. and Gutierrez-Adan, A. (2004) 'Long-term effect of in vitro culture of mouse embryos with serum on mRNA expression of imprinting genes, development, and behavior', *Proc Natl Acad Sci U S A* 101(16): 5880-5.
- Fong, B., Watson, P. H. and Watson, A. J. (2007) 'Mouse preimplantation embryo responses to culture medium osmolarity include increased expression of CCM2 and p38 MAPK activation', *BMC Dev Biol* 7: 2.
- Gardner DK. (2008) 'Dissection of culture media for embryos: the most important and less important components and characteristics', *Reprod Fertil Dev* 20(1): 9-18.
- Gutierrez-Adan, A., Lonergan, P., Rizos, D., Ward, F. A., Boland, M. P., Pintado, B. and de la Fuente, J. (2001) 'Effect of the in vitro culture system on the kinetics of blastocyst development and sex ratio of bovine embryos', *Theriogenology* 55(5): 1117-26.
- Halliday, J., Oke, K., Breheny, S., Algar, E. & D, J.A. Beckwith-Wiedemann syndrome and IVF: a case-control study', *Am J Hum Genet* 75, 526-528 (2004).
- Hargreaves, D. C. and Crabtree, G. R. (2011) 'ATP-dependent chromatin remodeling: genetics, genomics and mechanisms', *Cell Res* 21: 396-420; doi:10.1038/cr.2011.32
- Harlow, G. M. and Quinn, P. (1982) 'Development of preimplantation mouse embryos in vivo and in vitro', *Aust J Biol Sci* 35(2): 187-93.
- Hatada, I. and Mukai, T. (1995) 'Genomic imprinting of p57KIP2, a cyclin-dependent kinase inhibitor, in mouse', *Nat Genet* 11(2): 204-6.
- Hatada, I., Ohashi, H., Fukushima, Y., Kaneko, Y., Inoue, M., Komoto, Y., Okada, A., Ohishi, S., Nabetani, A., Morisaki, H. et al. (1996) 'An imprinted gene p57KIP2 is mutated in Beckwith-Wiedemann syndrome', *Nat Genet* 14(2): 171-3.
- Houghton, F. D., Hawkhead, J. A., Humpherson, P. G., Hogg, J. E., Balen, A. H., Rutherford, A. J. and Leese, H. J. (2002) 'Non-invasive amino acid turnover predicts human embryo developmental capacity', *Hum Reprod* 17(4): 999-1005.
- Iwata, H., Shiono, H., Kon, Y., Matsubara, K., Kimura, K., Kuwayama, T. and Monji, Y. (2008) 'Effects of modification of in vitro fertilization techniques on the sex ratio of the resultant bovine embryos', *Anim Reprod Sci* 105(3-4): 234-44.
- Johnstone, E. D., Sibley, C. P., Lowen, B. and Guilbert, L. J. (2005) 'Epidermal growth factor stimulation of trophoblast differentiation requires MAPK11/14 (p38 MAP kinase) activation', *Biol Reprod* 73(6): 1282-8.
- Kallen, B., Finnstrom, O., Lindam, A., Nilsson, E., Nygren, K. G. and Olausson, P. O. (2010) 'Blastocyst versus cleavage stage transfer in in vitro fertilization: differences in neonatal outcome?', *Fertil Steril* 94(5): 1680-3.
- Kausche, A., Jones, G. M., Trounson, A. O., Figueiredo, F., MacLachlan, V. and Lolatgis, N. (2001) 'Sex ratio and birth weights of infants born as a result of blastocyst

- transfers compared with early cleavage stage embryo transfers', *Fertil Steril* 76(4): 688-93.
- Khosla, S., Dean, W., Brown, D., Reik, W. and Feil, R. (2001) 'Culture of preimplantation mouse embryos affects fetal development and the expression of imprinted genes', *Biol Reprod* 64(3): 918-26.
- Kidder, G. M. and Watson, A. J. (2005) 'Roles of Na,K-ATPase in early development and trophectoderm differentiation', *Semin Nephrol* 25(5): 352-5.
- Lee, M. H., Reynisdottir, I. and Massague, J. (1995) 'Cloning of p57KIP2, a cyclin-dependent kinase inhibitor with unique domain structure and tissue distribution', *Genes Dev* 9(6): 639-49.
- Leese, H. J. (1991) 'Metabolism of the preimplantation mammalian embryo', *Oxf Rev Reprod Biol* 13: 35-72.
- Leese, H. J. (2002) 'Quiet please, do not disturb: a hypothesis of embryo metabolism and viability', *Bioessays* 24(9): 845-9.
- Leese, H. J., Sturmey, R. G., Baumann, C. G. and McEvoy, T. G. (2007) 'Embryo viability and metabolism: obeying the quiet rules', *Hum Reprod* 22(12): 3047-50.
- Lehninger, A. L., Nelson, D. L. and Cox, M. M. (2005) *Lehninger principles of biochemistry*, New York: W.H. Freeman.
- Leppens-Luisier, G., Urner, F. and Sakkas, D. (2001) 'Facilitated glucose transporters play a crucial role throughout mouse preimplantation embryo development', *Hum Reprod* 16(6): 1229-36.
- Lesourd, F., Parant, O., Clouet-Delannoy, M. and Parinaud, J. (2006) 'Clinical and biological parameters influencing implantation: score to determine number of embryos to transfer', *Reprod Biomed Online* 12(4): 453-9.
- Lim, D., Bowdin, S. C., Tee, L., Kirby, G. A., Blair, E., Fryer, A., Lam, W., Oley, C., Cole, T., Brueton, L. A., Reik, W., Macdonald, F., and Maher, E. R. (2009) "Clinical and molecular genetic features of Beckwith-Weidemann syndrome associated with assisted reproductive technologies', *Hum Reprod* 24(3): 741-747.
- Ludwig, M., Katalinic, A., Gross, S., Sutcliffe, A., Varon, R. and Horsthemke, B. (2005) 'Increased prevalence of imprinting defects in patients with Angelman syndrome born to subfertile couples', *J Med Genet* 42(4): 289-91.
- Luna, M., Duke, M., Copperman, A., Grunfeld, L., Sandler, B. and Barritt, J. (2007) 'Blastocyst embryo transfer is associated with a sex-ratio imbalance in favor of male offspring', *Fertil Steril* 87(3): 519-23.
- Maher, E. R., Afnan, M. and Barratt, C. L. (2003) 'Epigenetic risks related to assisted reproductive technologies: epigenetics, imprinting, ART and icebergs?', *Hum Reprod* 18(12): 2508-11.
- Mann, M.R.W. (2005) 'Imprinting and epigenetics in mouse models and embryogenesis: understanding the requirement for both parental genomes' Encyclopedia of Genetics, Genomics, Proteomics and Bioinformatics. Eds Jorde, LB, Little, PFR, Dunn MJ, and Subramaniam, S, John Wiley & Sons, United Kingdom, p1-11.

- Mann, M. R., Lee, S. S., Doherty, A. S., Verona, R. I., Nolen, L. D., Schultz, R. M. and Bartolomei, M. S. (2004) 'Selective loss of imprinting in the placenta following preimplantation development in culture', *Development* 131(15): 3727-35.
- Market-Velker, B. A., Fernandes, A. D. and Mann, M. R. (2010b) 'Side-by-side comparison of five commercial media systems in a mouse model: suboptimal in vitro culture interferes with imprint maintenance', *Biol Reprod* 83(6): 938-50.
- Market-Velker, B. A., Zhang, L., Magri, L. S., Bonvissuto, A. C. and Mann, M. R. (2010a) 'Dual effects of superovulation: loss of maternal and paternal imprinted methylation in a dose-dependent manner', *Hum Mol Genet* 19(1): 36-51.
- Matsuoka, S., Thompson, J. S., Edwards, M. C., Bartletta, J. M., Grundy, P., Kalikin, L. M., Harper, J. W., Elledge, S. J. and Feinberg, A. P. (1996) 'Imprinting of the gene encoding a human cyclin-dependent kinase inhibitor, p57KIP2, on chromosome 11p15', *Proc Natl Acad Sci U S A* 93(7): 3026-30.
- Milki, A. A., Jun, S. H., Hinckley, M. D., Westphal, L. W., Giudice, L. C. and Behr, B. (2003) 'Comparison of the sex ratio with blastocyst transfer and cleavage stage transfer', *J Assist Reprod Genet* 20(8): 323-6.
- Min, J. K., Hughes, E., Young, D., Gysler, M., Hemmings, R., Cheung, A. P., Goodrow, G. J., Senikas, V., Wong, B. C., Sierra, S. et al. (2010) 'Elective single embryo transfer following in vitro fertilization', *J Obstet Gynaecol Can* 32(4): 363-77.
- Morgan, H. D., Santos, F., Green, K., Dean, W. and Reik, W. (2005) 'Epigenetic reprogramming in mammals', *Hum Mol Genet* 14 Spec No 1: R47-58.
- Morita, Y., Tsutsumi, O., Oka, Y. and Taketani, Y. (1994) 'Glucose transporter GLUT1 mRNA expression in the ontogeny of glucose incorporation in mouse preimplantation embryos', *Biochem Biophys Res Commun* 199(3): 1525-31.
- Natale, D. R., Paliga, A. J., Beier, F., D'Souza, S. J. and Watson, A. J. (2004) 'p38 MAPK signaling during murine preimplantation development', *Dev Biol* 268(1): 76-88.
- Niemann, H. and Wrenzycki, C. (2000) 'Alterations of expression of developmentally important genes in preimplantation bovine embryos by in vitro culture conditions: implications for subsequent development', *Theriogenology* 53(1): 21-34.
- Orstavik, K. H., Eiklid, K., van der Hagen, C. B., Spetalen, S., Kierulf, K., Skjeldal, O. and Buiting, K. (2003) 'Another case of imprinting defect in a girl with Angelman syndrome who was conceived by intracytoplasmic semen injection', *Am J Hum Genet* 72(1): 218-9.
- Paliga, A. J., Natale, D. R. and Watson, A. J. (2005) 'p38 mitogen-activated protein kinase (MAPK) first regulates filamentous actin at the 8-16-cell stage during preimplantation development', *Biol Cell* 97(8): 629-40.
- Pantaleon, M. and Kaye, P. L. (1998) 'Glucose transporters in preimplantation development', *Rev Reprod* 3(2): 77-81.
- Pantaleon, M., Ryan, J. P., Gil, M. and Kaye, P. L. (2001) 'An unusual subcellular localization of GLUT1 and link with metabolism in oocytes and preimplantation mouse embryos', *Biol Reprod* 64(4): 1247-54.
- Pegoraro, L. M., Thuard, J. M., Delalleau, N., Guerin, B., Deschamps, J. C., Marquant Le Guenne, B. and Humblot, P. (1998) 'Comparison of sex ratio and cell number of

- IVM-IVF bovine blastocysts co-cultured with bovine oviduct epithelial cells or with Vero cells', *Theriogenology* 49(8): 1579-90.
- Peippo, J. and Bredbacka, P. (1995) 'Sex-related growth rate differences in mouse preimplantation embryos in vivo and in vitro', *Mol Reprod Dev* 40(1): 56-61.
- Porat, N., Boehnlein, L. M., Barker, M. A., Kovacs, P. and Lindheim, S. R. (2010) 'Blastocyst embryo transfer is the primary determinant for improved outcomes in oocyte donation cycles', *J Obstet Gynaecol Res* 36(2): 357-63.
- Ray, J., Raymon, H. K. and Gage, F. H. (1995) 'Generation and culturing of precursor cells and neuroblasts from embryonic and adult central nervous system', *Methods Enzymol* 254: 20-37.
- Richter, K. S., Anderson, M. and Osborn, B. H. (2006) 'Selection for faster development does not bias sex ratios resulting from blastocyst embryo transfer', *Reprod Biomed Online* 12(4): 460-5.
- Rinaudo, P. and Schultz, R. M. (2004) 'Effects of embryo culture on global pattern of gene expression in preimplantation mouse embryos', *Reproduction* 128(3): 301-11.
- Rodenhiser, D. and Mann, M. (2006) 'Epigenetics and human disease: translating basic biology into clinical applications', *CMAJ* 174(3): 341-8.
- Rossignol, S., Steunou, V., Chalas, C., Kerjean, A., Rigolet, M., Viegas-Pequignot, E., Jouannet, P., Le Bouc, Y. and Gicquel C. (2006) 'The epigenetic imprinting defect of patients with Beckwith-Weidemann syndrome born after assisted reproductive technology is not restricted to the 11p15 region', *J Med Genet* 43(12): 902-907.
- Sasaki, H., Ferguson-Smith, A. C., Shum, A. S., Barton, S. C. and Surani, M. A. (1995) 'Temporal and spatial regulation of H19 imprinting in normal and uniparental mouse embryos', *Development* 121(12): 4195-202.
- Shen, X. H., Han, Y. J., Yang, B. C., Cui, X. S. and Kim, N. H. (2009) 'Hyperglycemia reduces mitochondrial content and glucose transporter expression in mouse embryos developing in vitro', *J Reprod Dev* 55(5): 534-41.
- Shoukir, Y., Campana, A., Farley, T. and Sakkas, D. (1997) 'Early cleavage of in-vitro fertilized human embryos to the 2-cell stage: a novel indicator of embryo quality and viability', *Hum Reprod* 12(7): 1531-6.
- Sills, E. S. and Palermo, G. D. (2010) 'Human blastocyst culture in IVF: current laboratory applications in reproductive medicine practice', *Rom J Morphol Embryol* 51(3): 441-5.
- Sinclair, K. D., McEvoy, T. G., Maxfield, E. K., Maltin, C. A., Young, L. E., Wilmut, I., Broadbent, P. J. and Robinson, J. J. (1999) 'Aberrant fetal growth and development after in vitro culture of sheep zygotes', *J Reprod Fertil* 116(1): 177-86.
- Stokes, P. J., Hawkhead, J. A., Fawthrop, R. K., Picton, H. M., Sharma, V., Leese, H. J. and Houghton, F. D. (2007) 'Metabolism of human embryos following cryopreservation: implications for the safety and selection of embryos for transfer in clinical IVF', *Hum Reprod* 22(3): 829-35.

- Sturmey, R. G., Hawkhead, J. A., Barker, E. A. and Leese, H. J. (2009a) 'DNA damage and metabolic activity in the preimplantation embryo', *Hum Reprod* 24(1): 81-91.
- Sturmey, R. G., Reis, A., Leese, H. J. and McEvoy, T. G. (2009b) 'Role of fatty acids in energy provision during oocyte maturation and early embryo development', *Reprod Domest Anim* 44 Suppl 3: 50-8.
- Summers, M. C. and Biggers, J. D. (2003) 'Chemically defined media and the culture of mammalian preimplantation embryos: historical perspective and current issues', *Hum Reprod Update* 9(6): 557-82.
- Sutcliffe, A. G., Peters, C. J., Bowdin, S., Temple, K., Reardon, W., Wilson, L., Clayton-Smith, J., Brueton, L. A., Bannister, W. and Maher, E. R. (2006) 'Assisted reproductive therapies and imprinting disorders--a preliminary British survey', *Hum Reprod* 21(4): 1009-11.
- Team, R. D. C. (2011) *A Language and Environment for Statistical Computing*. Vienna, Austria: R Foundation for Statistical Computing.
- Uechi, H., Tsutsumi, O., Morita, Y. and Taketani, Y. (1997) 'Cryopreservation of mouse embryos affects later embryonic development possibly through reduced expression of the glucose transporter GLUT1', *Mol Reprod Dev* 48(4): 496-500.
- Valdivia, R. P., Kunieda, T., Azuma, S. and Toyoda, Y. (1993) 'PCR sexing and developmental rate differences in preimplantation mouse embryos fertilized and cultured in vitro', *Mol Reprod Dev* 35(2): 121-6.
- Van Montfoort, A. P., Dumoulin, J. C., Kester, A. D. and Evers, J. L. (2004) 'Early cleavage is a valuable addition to existing embryo selection parameters: a study using single embryo transfers', *Hum Reprod* 19(9): 2103-8.
- Verona, R. I., Mann, M. R. W. and Bartolomei, M. S. (2003) 'Genomic Imprinting: Intricacies of epigenetic regulation in clusters'. *Annual Review of Cell and Developmental Biology* 19:237-259.
- Wang, Y. A., Kovacs, G. and Sullivan, E. A. (2010) 'Transfer of a selected single blastocyst optimizes the chance of a healthy term baby: a retrospective population based study in Australia 2004-2007', *Hum Reprod* 25(8): 1996-2005.
- Watson, A. J. and Barcroft, L. C. (2001) 'Regulation of blastocyst formation', *Front Biosci* 6: D708-30.
- Watson, A. J., Damsky, C. H. and Kidder, G. M. (1990) 'Differentiation of an epithelium: factors affecting the polarized distribution of Na<sup>+</sup>,K<sup>(+)</sup>-ATPase in mouse trophectoderm', *Dev Biol* 141(1): 104-14.
- Weitzman, V. N., Schnee-Riesz, J., Benadiva, C., Nulsen, J., Siano, L. and Maier, D. (2010) 'Predictive value of embryo grading for embryos with known outcomes', *Fertil Steril* 93(2): 658-62.
- Weston, G., Osianlis, T., Catt, J. and Vollenhoven, B. (2009) 'Blastocyst transfer does not cause a sex-ratio imbalance', *Fertil Steril* 92(4): 1302-5.
- Windt, M. L., Kruger, T. F., Coetzee, K. and Lombard, C. J. (2004) 'Comparative analysis of pregnancy rates after the transfer of early dividing embryos versus slower dividing embryos', *Hum Reprod* 19(5): 1155-62.

- Winger, Q. A., Guttormsen, J., Gavin, H. and Bhushan, F. (2007) 'Heat shock protein 1 and the mitogen-activated protein kinase 14 pathway are important for mouse trophoblast stem cell differentiation', *Biol Reprod* 76(5): 884-91.
- Yan, Y., Frisen, J., Lee, M.H., Massague, J. and Barbacid, M. (1997) 'Ablation of the CDK inhibitor p57<sup>Kip2</sup> results in increased apoptosis and delayed differentiation during mouse development', *Genes Dev* 11(8): 973–983.
- Zhang, P., Liegeois, N.J., Wong, C., Finegold, M., Hou, H., Thompson, J.C., Silverman, A., Harper, J.W., DePinho, R.A. and Elledge, S.J. (1997) Altered cell differentiation and proliferation in mice lacking p57<sup>KIP2</sup> indicates a role in Beckwith–Wiedemann syndrome', *Nature* 387(6629): 151–158.

## **Chapter 5 - The Effects of Superovulation and Embryo Culture at the *Peg1/Mest***

### **Locus**

The work in this chapter originates from the following manuscript:

Market Velker, B. A., Denomme, M. M., Mann, M. R. 'A comprehensive evaluation of the effects of superovulation and embryo culture on the acquisition and maintenance of genomic imprinting of *Peg1/Mest*' submitted for publication in the journal *Biology of Reproduction*, in June 2011.

### **5.1 Introduction**

Genomic imprinting is an epigenetic phenomenon where gene expression is regulated according to parent-of-origin; one parental allele is expressed while the other is repressed (Reik and Walter, 2001; Rodenhiser and Mann, 2006). To date, approximately 150 genes have been identified whose expression is regulated in such a manner ([http://www.har.mrc.ac.uk/research/genomic\\_imprinting/maps.html](http://www.har.mrc.ac.uk/research/genomic_imprinting/maps.html)) (Morison et al., 2005). Many of these imprinted genes play critical roles in the development of the embryo and placenta, or influence behaviour after birth (Ono et al., 2006; Varrault et al., 2006; Wilkinson et al., 2007; Bressan et al., 2009; Broad et al., 2009), and their dysregulation has been linked to a group of human diseases called imprinting disorders. Two important time periods have been identified with respect to genomic imprinting: acquisition (during gametogenesis) and maintenance (during preimplantation development). Numerous



assisted reproductive technologies take place during these two critical periods, and as such have the potential to disrupt acquisition and/or maintenance of genomic imprinting.

The development and increased use of assisted reproductive technologies (ARTs) for the treatment of infertility/subfertility, led to the observation that genomic imprinting may be affected by *ex vivo* manipulation of the early embryo. In addition to BWS and AS, studies have suggested a relationship between Silver-Russell Syndrome (SRS), and dysregulation of imprinted genes by ARTs. SRS is an imprinting disorder characterized by intrauterine and post-natal growth retardation (Wollmann et al., 1995). Up to 44% of SRS cases are associated with hypomethylation of the *H19* ICR within the 11p15 region (Eggermann et al., 2010), which harbours the imprinted genes *H19* and *Igf2*, while maternal uniparental disomy of chromosome 7 has been implicated in approximately 5% of cases of SRS (Kotzot et al., 1995; Eggermann et al., 2010), a region that contains the *Peg1/Mest* gene.

*Peg1/Mest* has been proposed as one of the causative agents of SRS (Hannula et al., 2001; Chou et al., 2004; Kagami et al., 2007). Paternal inheritance of a targeted *Peg1/Mest* allele results in severe IUGR in the offspring, while maternal inheritance of the deleted allele does not (Lefebvre et al., 1998). On the other hand, high levels of *Peg1/Mest* expression has been found in adipocytes from obese mice, and transgenic overexpression of *Peg1/Mest* results in enlargement of adipocytes (Takahashi et al., 2005). This suggests a key role for *Peg1/Mest* in regulating fetal growth.

Genomic imprinting of *Peg1/Mest*, which is located on mouse chromosome 6 and human chromosome 7, was identified through subtractive hybridization comparing

normal and parthenogenetic mouse embryos (Kaneko-Ishino et al., 1995). Paternal monoallelic expression of *Peg1/Mest* has been confirmed in adult tissues (Reule et al., 1998), and in a number of other species including humans (Kobayashi et al., 1997; Riesewijk et al., 1997), tammar wallaby (Suzuki et al., 2005), and sheep (Feil et al., 1998). A CpG island spanning the putative promoter region and exon 1 is methylated in a parent-of-origin specific manner: the maternal allele is methylated while the paternal allele is unmethylated (Riesewijk et al., 1997; Nishita et al., 1999). Acquisition of imprinted DNA methylation at the maternal differentially methylated region (DMR) occurs at the tertiary/early antral follicle stage, after the majority of other imprinted genes have already acquired their methylation (Obata and Kono, 2002; Hiura et al., 2006), and continues after ovulation (Imamura et al., 2005). This has led to suggestions that the *Peg1/Mest* imprint may be more vulnerable to perturbation by environmental insult (Anckaert et al., 2010). A number of studies have demonstrated differences in the response of *Peg1/Mest* to various environmental insults during oocyte development, including superovulation and *in vitro* maturation when compared to other imprinted genes, such as *H19* and *Snrpn* (Khosla et al., 2001; Liang et al., 2008; Tveden-Nyborg et al., 2008; Anckaert et al., 2010).

In this study, we characterize the effects of two commonly used procedures in ART, superovulation and embryo culture, on the acquisition and maintenance of genomic imprinting at the *Peg1/Mest* locus. Superovulation, also known as ovarian hyperstimulation, is used to recover large numbers of mature oocytes, while embryo culture facilitates the development of embryos through preimplantation stages. To

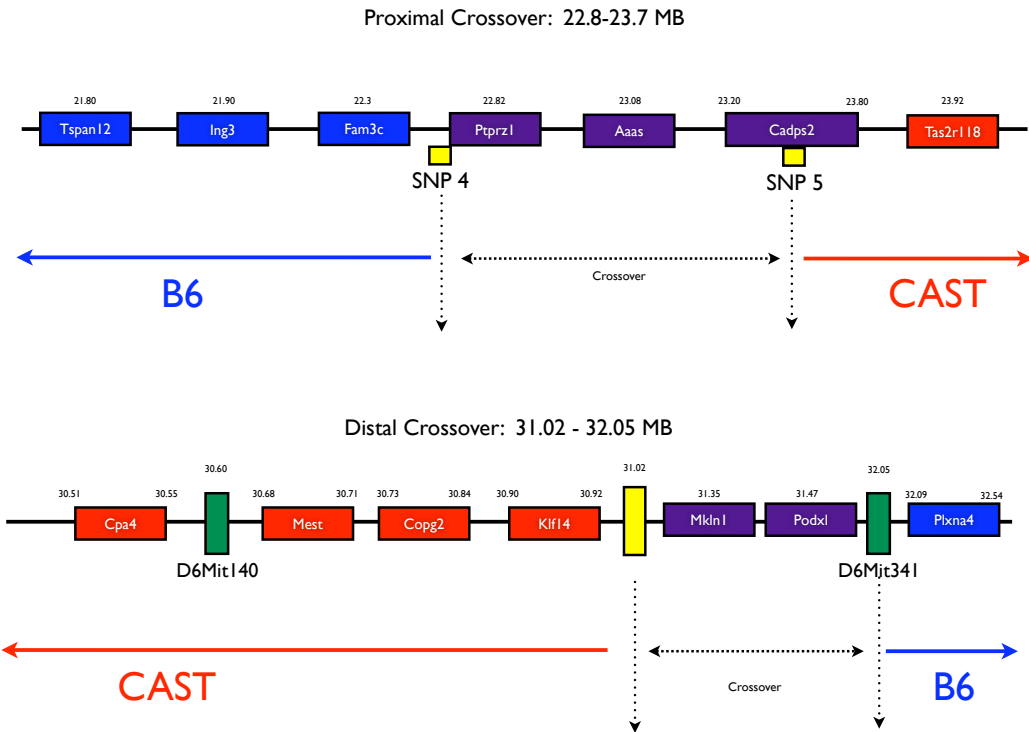
provide a comprehensive allelic analysis of the response of the *Peg1/Mest* locus to these procedures, and to avoid confounding factors that have prevented detailed analysis in other studies such as intrinsic patient subfertility, and the use of pooled oocytes/embryos, our analysis was performed using a mouse model on individual oocytes and blastocyst stage embryos. We demonstrate that DNA methylation at the maternal *Peg1/Mest* DMR is maintained in ovulated metaphase II (MII) oocytes following low or high dose superovulation, indicating that acquisition of *Peg1/Mest* imprinted methylation in the developing oocyte is not affected by hormonal stimulation. However, a significant loss of maternal methylation at the *Peg1/Mest* DMR was observed at the blastocyst stage following superovulation or embryo culture, indicating that maintenance of genomic imprinting was disrupted by these interventions, although no correlation to rates of preimplantation development was observed.

## **5.2 Methods**

### **5.2.1 B6(CAST7p6) Mouse Model**

Previous studies from our lab utilized a mouse model ideally suited for imprinting analyses, C57BL/6(CAST7) (B6(CAST7)) that contain two *Mus musculus castaneus* chromosome 7s on a B6 background. Polymorphisms between B6(CAST7) and C57BL/6 (B6) mice allow for subsequent identification of maternal and paternal alleles. Investigation of *Peg1/Mest* was not possible using this model, as *Peg1/Mest* is located on chromosome 6 in the mouse. To identify C57BL6(CAST7partial6) [B6(CAST7p6)]

mice, we screened our original B6(CAST7) colony by microsatellite marker mapping and found a subset of mice that harboured the same partial region of *M.m. castaneus* chromosome 6. Using microsatellite markers, D6Mit140 and D6Mit34, as well as allelic PCR-restriction digest of published polymorphisms, crossover events were mapped to 22.8-23.7 and 31.02-32.05 MB, a 9.25 MB region that contained the entire *Peg1/Mest* imprinted domain (Figure 5.1). The proximal crossover was mapped to between SNP#4 (rs3090864) and SNP #5 (rs3088527). The PCR primers for SNP#4 were F: 5'-GTGCCAGATTGTCTTCCC-3', and R: 5'-ACCCTCAGGACAGTTCG-3', and for SNP#5 were F: 5'-ATGCCTCATTGGAGTCTG-3', and R: 5'-AGCATCCTCTGGGAGTGTA-3'. For SNP#4, a polymorphic A/G restriction site between B6 (A) and CAST (G) distinguished the parental alleles, as the CAST (G) allele is cleaved by the HpyCH4III restriction enzyme (B6: 181 and 12 bp, CAST: 101, 80 and 12 bp). For SNP#5, a polymorphic A/C restriction site between B6 (C) and CAST (A) distinguished parental alleles, with the CAST allele cleaved by the restriction enzyme CviKI-1 (B6: 74, 54, and 38 bp, CAST: 112 and 54 bp). The distal crossover was mapped to a region between the MapPairs D6Mit341 and D6Mit140. To determine if the *Peg1/Mest* imprinted domain was within the CAST region, another polymorphism, SNP#10 (rs6183467), outside the domain was investigated using the following primers F: 5'-CAGGATGGGTCTGGAGTGA-3' and R: 5'-CTTAGTAGCAACTGGGTGGTG-3'. A polymorphic T/G restriction site between B6 (T) and CAST (G) was observed, and restriction digest with the enzyme HincII resulted in cleavage of the CAST allele. All polymorphisms were confirmed by sequencing of the PCR products. SNP#4 was used for



**Figure 5.1: Crossover Sites in the B6(CAST7p6) Mouse Model**

Graphical representation of chromosome 6 in our B6(CAST7p6) mouse model. Genes in red are located within the known *M. m. castaneus* region, genes in blue are located within the known B6 region, and genes in purple fall within the crossover region. Green boxes represent MapPairs that were used to genotype the mice. Yellow boxes represent sites of single nucleotide polymorphisms (SNPs) that were used as restriction sites to determine genotypes. The *Peg1/Mest* imprinted domain was found to reside within the *M. m. castaneus* region.

the allelic PCR-restriction digestion genotyping assay to identify B6(CAST7p6) mice. B6(CAST7p6) intercrosses were used to generate a B6(CAST7p6) mouse colony. This B6(CAST7p6) mouse model was used for all subsequent experiments.

### **5.2.2 Oocyte and Embryo Collection and Culture**

Ovulated oocytes were collected from B6(CAST7p6)xB6 F<sub>1</sub> females following superovulation, or spontaneous ovulation for controls. F<sub>1</sub> females have one CAST chromosome 7 and a partial CAST chromosome 6 on a B6 background inherited from the mother, and a B6 chromosome set inherited from the father, allowing for identification of grandparental inheritance at the *Peg1/Mest* locus within the oocyte following meiosis.

Superovulated females were injected with either 6.25 IU or 10 IU Pregnant Mare's Serum Gonadotropin (PMSG, Intervet Canada) followed 40-44 hours later by the same dose of human Chorionic Gonadotropin (hCG, Intervet Canada). Oocyte-cumulus cell complexes were flushed from the oviducts at approximately 12 PM the following day (22 hours post-hCG) into M2 media (Sigma). MII stage oocytes were dissociated from surrounding cumulus cells using 0.3 mg/ml Hyaluronidase (Sigma) and were washed three times in 30 µl of M2 media. Diameter and volume measurements were recorded for each individual oocyte using the Olympus IX81 microscope. Oocytes were treated with Acidic Tyrode's solution (Sigma) at room temperature for removal of the zona pellucida, washed twice more in M2 media, and individually placed on a glass slide in minimal media. Oocytes were gently mixed with a small amount of 2:1 agarose:lysis solution [20 µl 3% low melting point agarose (Sigma)], 8 µl Dynabead lysis buffer (see below), 1 µl 2

mg/ml proteinase K (Sigma), 1  $\mu$ l 10% IPEGAL (Sigma) at 70°C, embedded in 10  $\mu$ l of this solution and placed in an eppendorf tube containing 300  $\mu$ l of mineral oil. Following a 10 minute incubation on ice to allow the agarose bead to harden, mineral oil was removed and 500  $\mu$ l of Dynabead lysis buffer was added [100 mM Tris-HCl pH 7.5 (Bioshop), 500 mM LiCl (Sigma), 10 mM EDTA pH 8.0 (Sigma), 1% LiDS (Bioshop), 5 mM DTT (Sigma)]. Individual samples were incubated overnight in a 50°C waterbath.

The following morning (~20 hours later), Dynabead lysis buffer was removed and 300  $\mu$ l mineral oil was again added to the bead. Samples were incubated at 90°C for 2.5 minutes (Proteinase K inactivation), and were then placed on ice for 10 minutes. Bisulfite mutagenesis was performed as described (Market-Velker et al., 2010a) with the following exception: each oocyte sample was directly added as a solid agarose bead to a ready-to-go PCR bead (GE) containing *Peg1/Mest* specific primers and 1  $\mu$ l of 240 ng/ml tRNA in a 15  $\mu$ l solution, with 25  $\mu$ l mineral oil overlay. Negative controls (agarose bead without oocyte) were processed alongside each sample. The first round nested PCR was performed with an annealing temperature of 50°C. For the second round, 5  $\mu$ l of first round product was added to a second 25  $\mu$ l ready-to-go PCR bead, with *Peg1/Mest* specific primers but without tRNA, with 25  $\mu$ l mineral oil overlay. The second round nested PCR was performed using an annealing temperature of 54°C.

Embryos were obtained from B6(CAST7p6) females crossed with B6 males (Charles River, St Constant, Canada). For *in vivo*-derived embryos, female B6(CAST7p6) mice were checked for estrus, and mated with B6 males. For the superovulated group, females were injected with either 6.25 or 10 IU of PMSG, followed

by the same dose of hCG, 40-44 hours later. Females were mated with B6 males the same day as hCG injection. In both groups, pregnancy was determined by the presence of a vaginal plug at 0.5 days postcoitum (dpc). F<sub>1</sub> hybrid 2-cell embryos were flushed from the oviducts of B6(CAST7p6) females at 1.5 dpc, washed twice and cultured in Whitten's medium (made in-house) (Whitten, 1971). Embryo culture drops were prepared prior to 9 AM the morning of embryo collection or embryo separation, and allowed to equilibrate. Embryos were cultured in either 10, 15 or 20 µL drops, with filter-sterilized mineral oil overlay (Sigma), at a concentration of 1 embryo per microliter. Embryos were separated into four groups based on rates of development over the course of the 3 day culture period as described in Chapter 4.

Control blastocyst stage embryos were flushed from uteri of B6(CAST7p6) females in M2 Medium (Sigma) at 3.5 dpc (~96 hours post-hCG). Cultured embryos and embryos collected at the blastocyst stage were frozen in individual tubes, snap frozen on dry ice and stored at -80°C.

### **5.2.3 Analysis of *Peg1/Mest* Imprinted Methylation and Expression**

The combined analysis of imprinted methylation and expression in individual blastocysts was performed as previously described using the cDNA library generated for each embryo (Market-Velker et al., 2010b). The following primers were used for the analysis of imprinted expression of *Peg1/Mest* (NM\_008590; 1380-1920): Forward 5'-CACATTGGTGAACAACTACAGG-3'(1PG2), Reverse 5'-AGAGTGCTGGGAACTGAACC-3'(1PG5). Amplification of a 541 bp fragment



containing an allelic polymorphism between B6 (C) and CAST (A) (position 1679, NM\_008590) was tested using SYBR green to allow determination of the range of cycles located in log-phase amplification. PCR on subsequent embryos was performed to ensure that amplification was log-phase upon completion of the PCR program. Following amplification using ready-to-go PCR Beads, embryos were digested with the BsiHKA1 restriction enzyme to determine allelic identity; the B6 allele is cleaved into 270 and 271 bp fragments, while the CAST allele is uncut. Densitometry was performed using the Opticon Monitor Software.

For imprinted methylation, bisulfite mutagenesis, nested PCR, cloning and sequencing was performed as described previously (Chapter 3) (Market-Velker et al., 2010b). Analysis of 15 CpGs in the *Peg1/Mest* DMR (AF017994; 1309-1651) was performed using the following primers: outer primers; Peg1B 5'-TTTTAGATTTTGAGGGTTTTAGGTTG-3', and Peg1E 5'-TCATTAAAACACAAACCTCCTTAC-3', 50°C annealing temperature; inner primers; Peg1C 5'-GGTGTTGGTATTTTTAGTGTTAGTTG-3', and Peg1D 5'-AATCCCTTAAAATCATCTTTCACAC-3', 57.5°C annealing temperature. Primers were designed within the region described by Anckaert et al (Anckaert et al., 2010). At least 40 clones per embryo were sequenced, and each sequence was analyzed as described previously (Chapter 3) (Market-Velker et al., 2010b). Hypermethylation of a DNA strand was defined as > 50% methylated CpGs on a given strand.

For each oocyte, 5 clones were sequenced. Since individual oocytes are expected to have a single strand of DNA amplified, any samples having more than one methylation

pattern were excluded from analysis, due to implied cumulus cell contamination. Sequences with conversion rates < 85% were not included.

#### **5.2.4 Statistical Analysis**

Statistical analysis was performed comparing loss of methylation between *in vivo*-derived embryos, superovulated embryos (6.25 IU and 10 IU) and *in vitro* cultured embryos. The Fisher's exact test was used to compute the significance of non-random association between these groups of embryos. A one-sided test was utilized as methylation changes were anticipated to be only in one direction. P-values less than 0.05 were considered to be significant, and were calculated using the following online software: <http://faculty.vassar.edu/lowry/fisher.html>

### **5.3 Results**

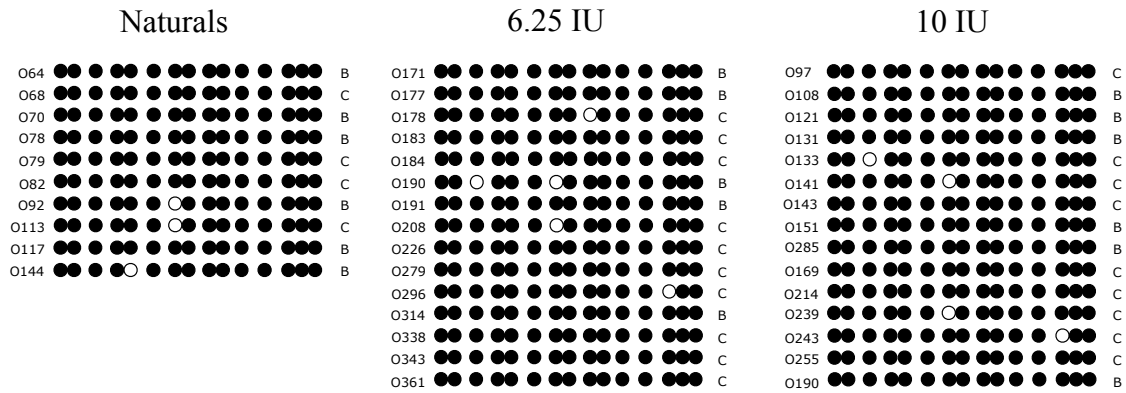
#### **5.3.1 Effects of Superovulation on *Peg1/Mest* Imprinted Methylation in Oocytes**

In this study, we set out to determine the effects of superovulation on *Peg1/Mest* imprinted methylation in ovulated oocytes. Furthermore, we wanted to determine whether the original maternal and paternal *Peg1/Mest* alleles displayed differential sensitivity to hormone treatment. During oogenesis, imprinted methylation acquisition may occur differentially between the parental alleles as evidence indicates that methylation of the *Snrpn* grand-maternal allele is established prior to that on the

grandpaternal allele (Lucifero et al., 2004). By using B6(CAST7p6) F<sub>1</sub> females, we can distinguish between the *Peg1/Mest* grandmaternal (CAST7p6) and grandpaternal (B6) alleles within individual oocytes.

To assess effects of superovulation on imprinted methylation, our recently developed single cell bisulfite mutagenesis assay was used to determine the methylation status of 15 CpGs located in the *Peg1/Mest* DMR. Amplification was successful in 36% of individual oocytes (10/28) from spontaneously ovulating B6(CAST7p6) females, all of which displayed 100% hypermethylation (Figure 5.2).

To investigate the effects of superovulation on the acquisition of genomic imprints at the *Peg1/Mest* DMR, we analyzed oocytes from B6(CAST7p6)XB6 females superovulated with either 6.25 IU or 10 IU hormone treatment. Following bisulfite mutagenesis amplification was successful for 38% of 6.25 IU individual oocytes (17/45) and 40% of 10 IU individual oocytes (20/50). Following exclusion of samples with cumulus cell contamination (1/16 6.25 IU, 5/20 10 IU oocytes), all individual oocytes from hormone-treated females showed 100% *Peg1/Mest* DMR hypermethylation (Figure 5.2). Thus, we conclude that superovulation does not alter acquisition of genomic imprinting at the *Peg1/Mest* DMR, even at higher hormone treatment levels. In addition, as both grandmaternal (CAST7p6) and grandpaternal (B6) alleles displayed similar hypermethylation patterns, our results do not demonstrate differential allelic susceptibility of maternal imprint acquisition to perturbations by superovulation, at this point of analysis. Analysis of oocyte diameter and volume revealed no difference between oocytes derived from spontaneously and superovulated females (data not shown).

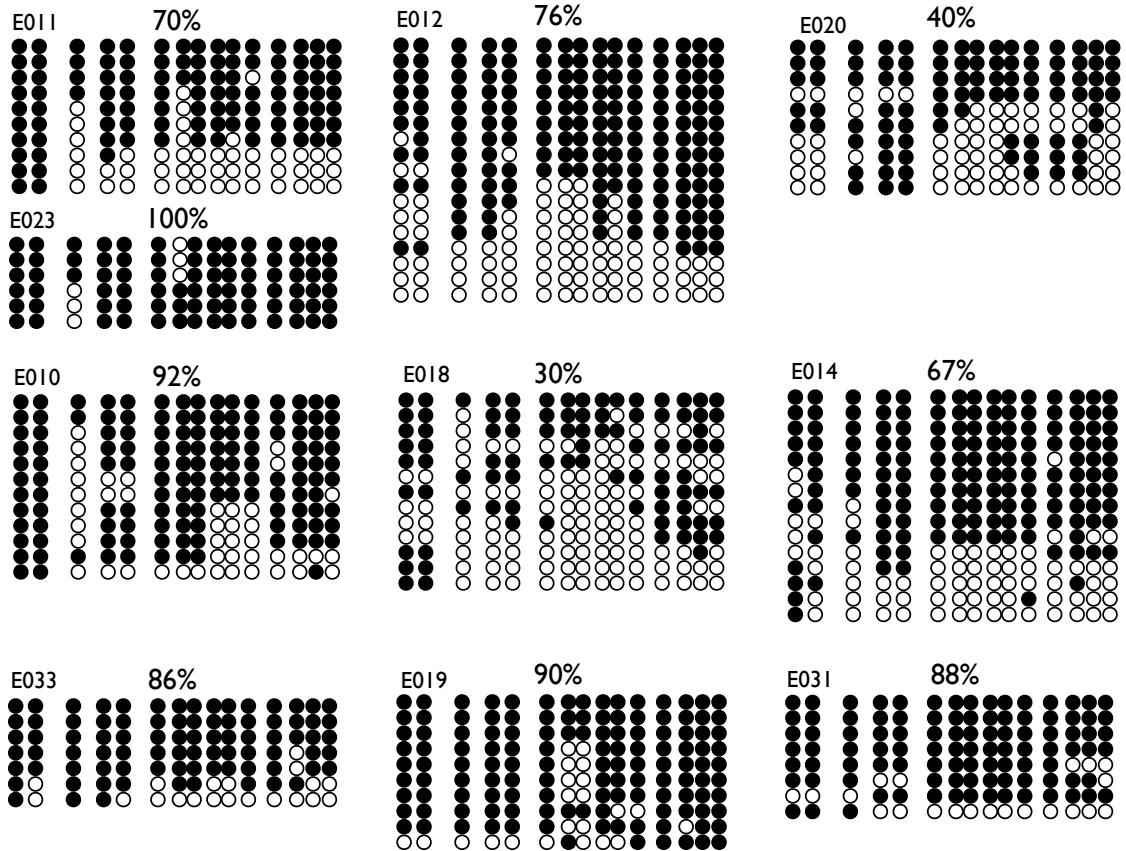


**Figure 5.2. Methylation of *Peg1/Mest* in Oocytes**

Methylation of the *Peg1/Mest* DMR in individual oocytes derived from spontaneously ovulated and superovulated B6(CAST7p6)xB6 F<sub>1</sub> females (6.25 and 10 IU). Unmethylated CpGs are represented as empty circles while methylated CpGs are depicted as filled circles. Each line denotes an individual strand of DNA from a single oocyte. Oocyte designations are indicated on the left of each DNA strand, allele is indicated on the right of each strand (B-B6, C-CAST). All oocytes displayed 100% hypermethylation. Hypermethylated DNA strands were those displaying >50% methylated CpGs.

### 5.3.2 *In Vivo* Patterns of Imprinted Methylation at the *Peg1/Mest* DMR in Blastocysts

Methylation patterns of *in vivo*-derived embryos have not been described at the *Peg1/Mest* DMR in blastocyst stage embryos. As such, prior to our investigation of superovulated or cultured embryos, we set out to determine the imprinted *Peg1/Mest* DNA methylation pattern in *in vivo*-derived blastocyst stage embryos in our mouse model. Using a modified bisulfite mutagenesis protocol to obtain information for individual blastocysts (Chapter 4), we determined the *Peg1/Mest* imprinted methylation patterns for 10 *in vivo*-derived B6(CAST7p6)xB6 embryos. We observed that 7 of the 10 embryos displayed high hypermethylation levels at the maternal *Peg1/Mest* DMR (E011 70%; E023 100%; E010 92%; E033 86%; E076%; E090%; E031 80%) while the remaining three embryos displayed lower levels of hypermethylation (E018 30%; E020 40%; E014 67%) (Figure 5.3). Using data from these embryos, we set our threshold for loss of methylation at 70% (74% average hypermethylation of the maternal allele), similar to *Snrpn* (Chapter 2; Market-Velker et al., 2010a). In our previous analysis of *H19*, *Kcnq1ot1* and *Peg3* methylation (Chapter 2; Market-Velker et al., 2010a), we observed that 10-20% of *in vivo*-derived blastocysts exhibited a loss of imprinted methylation (as evidenced by levels of methylation below our set thresholds). Notably for *Peg1/Mest*, three embryos show this pattern of hypermethylation. As *Peg1/Mest* has been reported to acquire methylation later in oocyte development, perhaps its methylation is more labile.



**Figure 5.3: Methylation of the *Peg1/Mest* DMR in Embryos derived from Spontaneously Ovulating Females.**

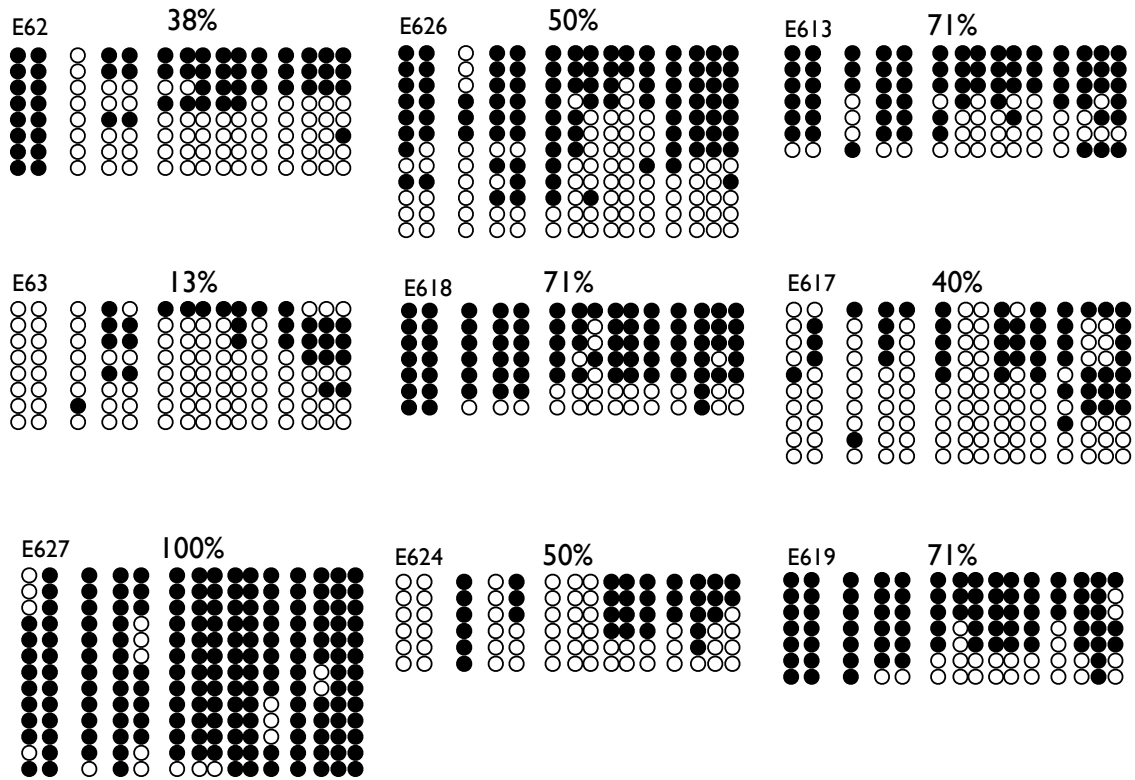
Methylation of the paternal *Peg1/Mest* DMR in B6(CAST7p6)xB6 F<sub>1</sub> embryos derived from spontaneously ovulated females. Each group of DNA strands represents one blastocyst. Unmethylated CpGs are represented as empty circles while methylated CpGs are depicted as filled circles. Each line denotes an individual strand of DNA, and each group of strands denotes an individual blastocyst. Blastocyst designations are indicated at the top left of each group, and % hypermethylation is indicated at the top center of each group. Percentages were calculated as the number of hypermethylated DNA strands/total number of DNA strands. Hypermethylated DNA strands were those displaying >50% methylated CpGs.

### **5.3.3 Effects of Superovulation on Imprinted Methylation at the *Peg1/Mest* DMR in Blastocysts**

To determine the effects of superovulation on *Peg1/Mest* imprinted methylation in embryos, we investigated methylation at the *Peg1/Mest* DMR in blastocysts from superovulated females treated with either 6.25 IU (low dose) or 10 IU (high dose). In the low dose hormone group, using 70% hypermethylation as our threshold, 5/9 embryos displayed loss of methylation (E62 38%; E63 13%; E617 40%; E626 50%; E624 50%), with a mean maternal hypermethylation level 56% (Figure 5.4). At the high hormone dosage, loss of methylation was observed in 9/11 embryos (E102 33%; E1018 0%, E1031 63%; E1034 58%; E101 67%; E1033 70%; E1032 20%; E105 63%; E104 13%), with a mean maternal hypermethylation level of 51% (Figure 5.5). Overall, an increase in the number of embryos displaying loss of methylation was observed in the low hormone treatment group compared to *in vivo*-derived controls, with a further increase observed in the high hormone treatment group, which was statistically significant ( $p = 0.02$ ). This is consistent with the behaviour of other imprinted loci in response to superovulation (Chapter 2; Market-Velker et al., 2010a).

### **5.3.4 Effects of Embryo Culture on Imprinted Methylation at the *Peg1/Mest* DMR in Blastocysts**

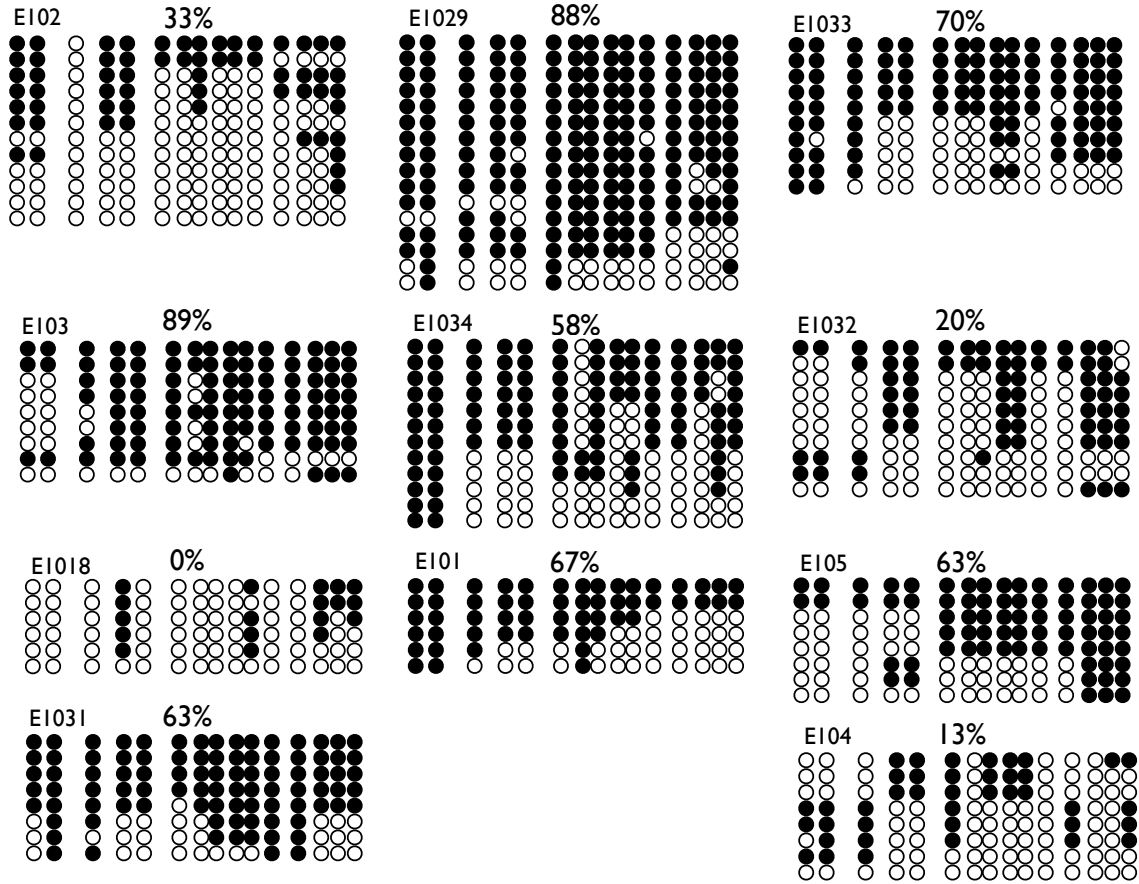
Embryo culture is another technique commonly used in the treatment of infertility. To evaluate the effects of embryo culture on imprinted methylation at the *Peg1/Mest*



**Figure 5.4: Methylation of the *Peg1/Mest* DMR in Embryos derived from Superovulated (6.25 IU) Females**

Methylation of the paternal *Peg1/Mest* DMR in B6(CAST7p6)xB6 F<sub>1</sub> embryos derived from superovulated (6.25 IU) females. See Figure 5.3 for additional information.





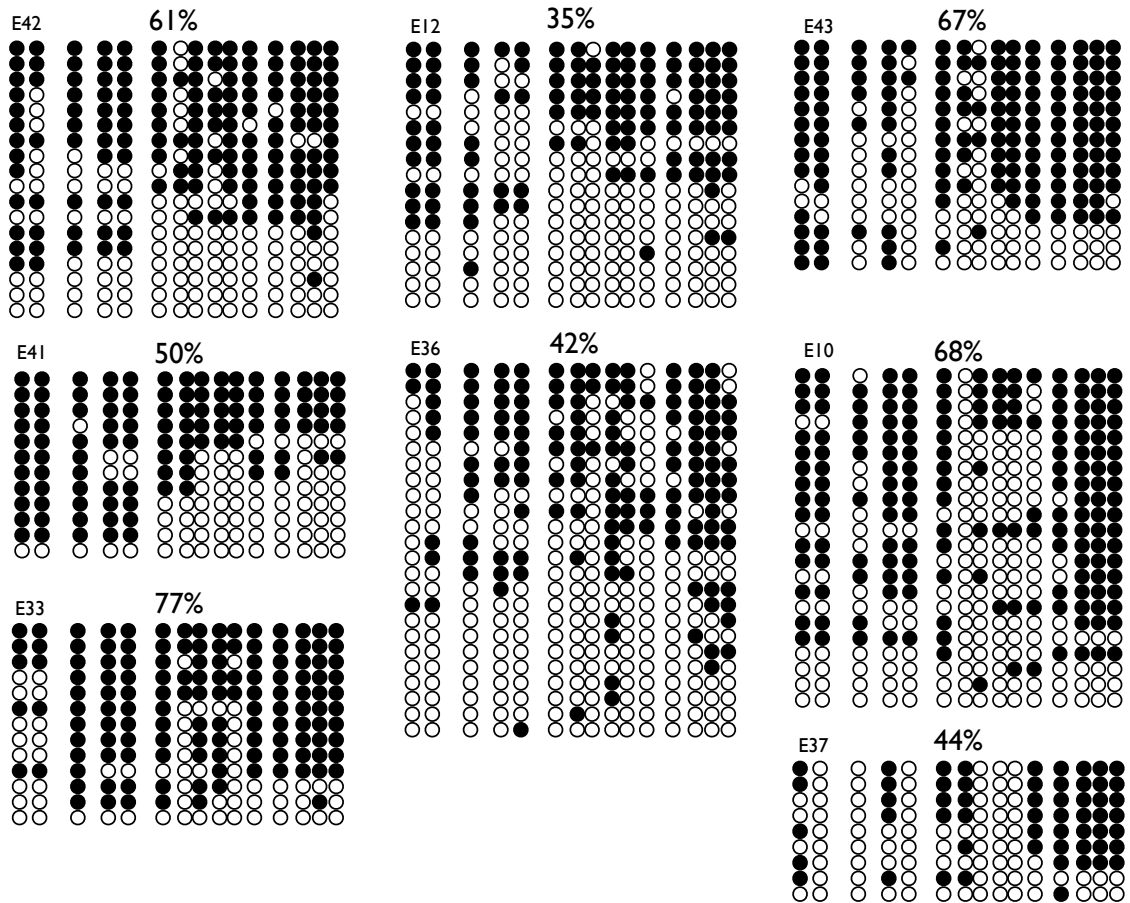
**Figure 5.5: Methylation of the *Peg1/Mest* DMR in Embryos derived from Superovulated (10 IU) Females**

Methylation of the paternal *Peg1/Mest* DMR in B6(CAST7p6)xB6 F<sub>1</sub> embryos derived from superovulated (10 IU) females. See Figure 5.3 for additional information.

DMR, we analyzed 23 individual embryos cultured from the 2-cell to the blastocyst stage in Whitten's medium (Figures 5.6-5.9). Embryos were separated based on rate of preimplantation development, as described in Chapter 4. In the FF group 7/8 embryos displayed loss of imprinting methylation (68%, 67%, 61%, 50%, 44%, 42%, 35%), 3/5 in the FS group (70%, 56%, 38%), 5/6 in the SF group (64%, 57%, 50%, 50%, 33%) and 3/5 in the SS group (56%, 50%, 43%). The average hypermethylation in each group were as follows: 56% FF, 63% FS, 55% SF, and 61% SS. Overall, the "Fast" group displayed loss of methylation in 10/13 embryos, corresponding to an average hypermethylation of 58%, and the "Slow" group displayed a loss of methylation in 8/11 embryos, also corresponding to an average hypermethylation of 58%. Unlike our previous study showing more severe loss of methylation in "Fast" developing embryos than the "Slow" group at the *H19* and *Snrpn* ICRs, no statistical difference was observed between the embryo culture groups at the *Peg1/Mest* DMR. In addition, no difference was observed when comparing embryos at the second separation (FF and SF vs FS and SS). Overall, significantly more cultured embryos (18/24) displayed levels of imprinted methylation below the 70% threshold ( $p = 0.02$ ), compared to the *in vivo* group (3/10).

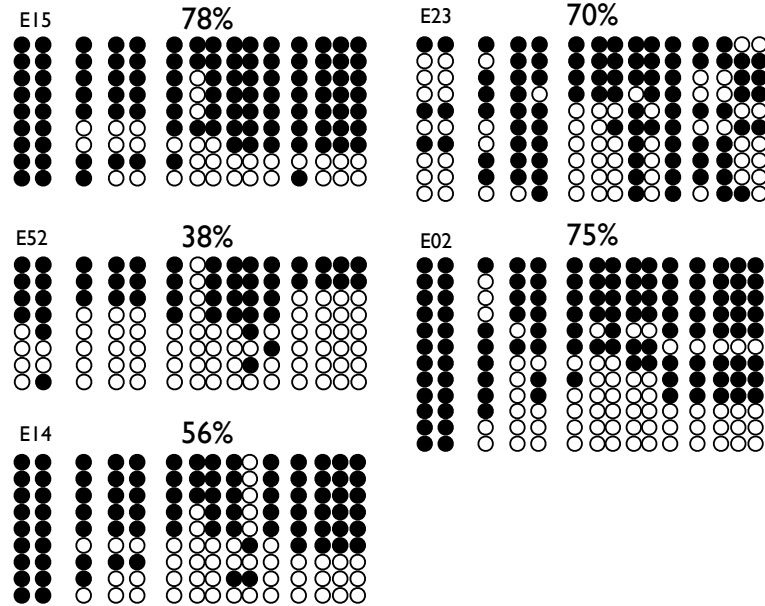
### **5.3.5 Effects of Superovulation and Embryo Culture on *Peg1/Mest* Imprinted Expression**

We also analyzed imprinted expression of *Peg1/Mest* in the same *in vivo*-derived embryos used for methylation analysis, using our technique for combined imprinted methylation and expression analysis in individual embryos (Market-Velker et al., 2010b).



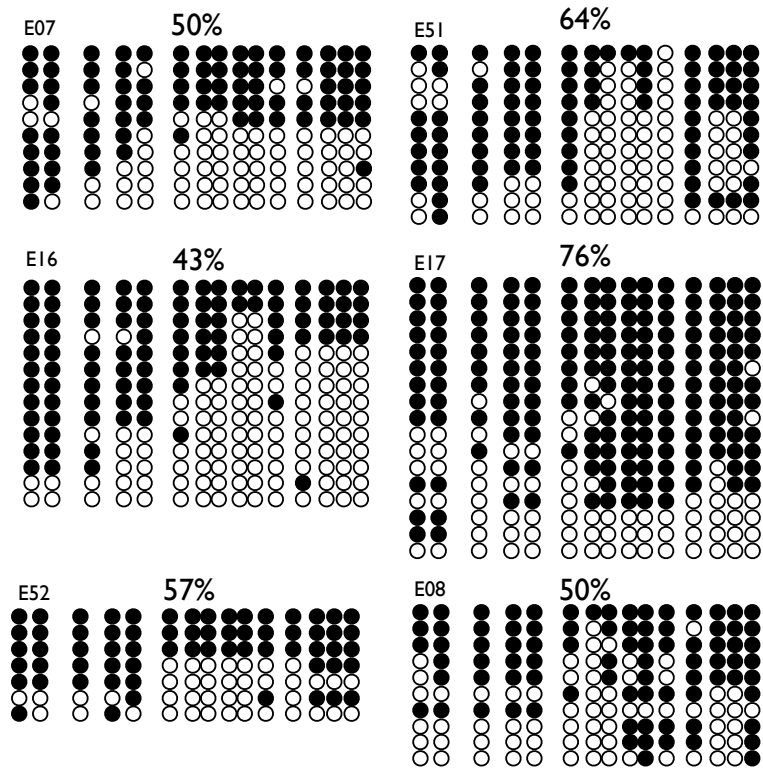
**Figure 5.6: Methylation of the *Peg1/Mest* DMR in Blastocysts From the FF Group**

Methylation of the paternal *Peg1/Mest* DMR in B6(CAST7p6)xB6 F<sub>1</sub> embryos from the Fast/Fast group, cultured in Whitten's medium. See Figure 5.3 for additional information. Imprinted expression in each embryo is indicated in orange next to each group.



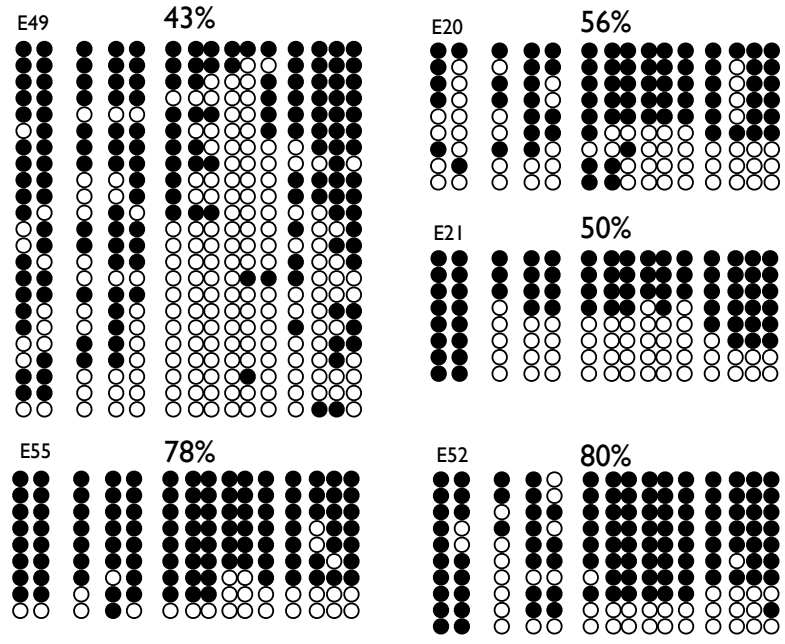
**Figure 5.7: Methylation of the *Peg1/Mest* DMR in Blastocysts From the FS Group**

Methylation of the paternal *Peg1/Mest* DMR in B6(CAST7p6)xB6 F<sub>1</sub> embryos from the Fast/Slow group, cultured in Whitten's medium. See Figure 5.3 and 5.6 for additional information.



**Figure 5.8: Methylation of the *Peg1/Mest* DMR in Blastocysts From the SF Group**

Methylation of the paternal *Peg1/Mest* DMR in B6(CAST7p6)XB6 F<sub>1</sub> embryos from the Slow/Fast group, cultured in Whitten's medium. See Figure 5.3 and 5.6 for additional information.



**Figure 5.9: Methylation of the *Peg1/Mest* DMR in Blastocysts From the SS Group**

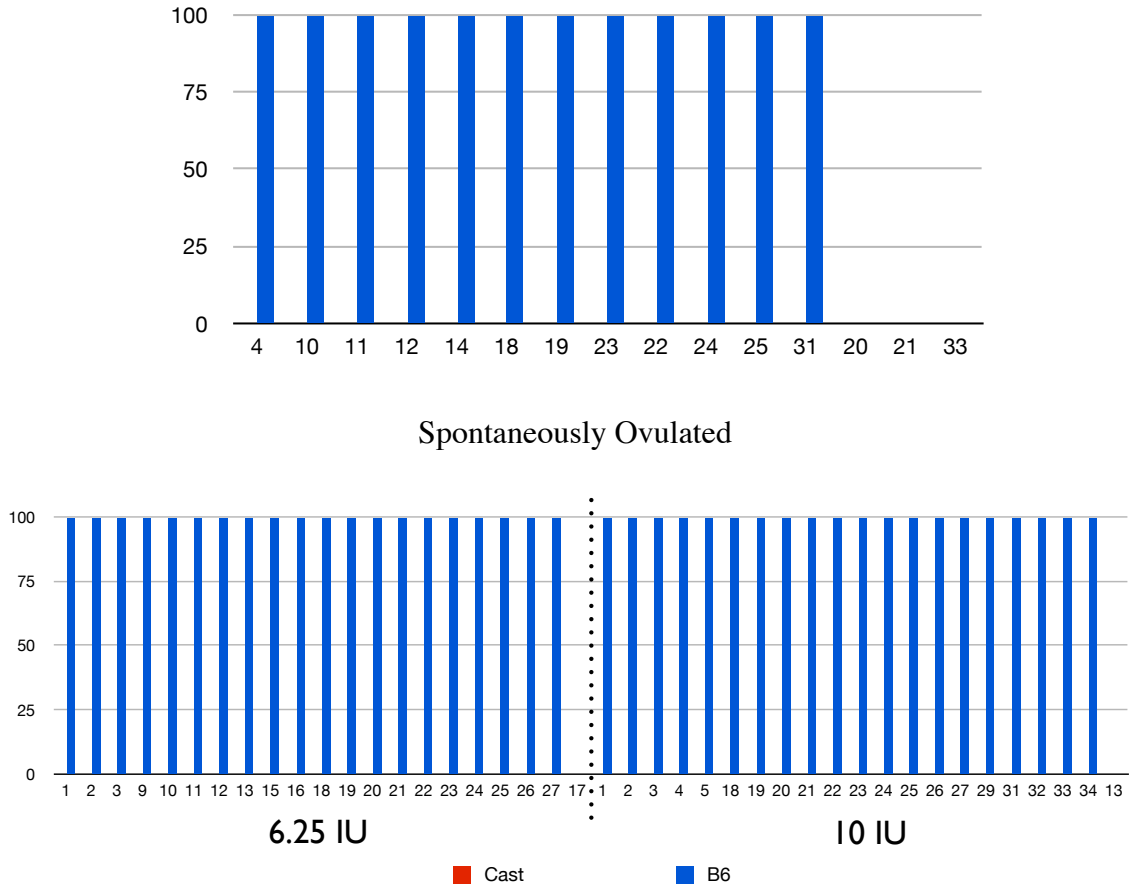
Methylation of the paternal *Peg1/Mest* DMR in B6(CAST7p6) X B6 F<sub>1</sub> embryos from the Slow/Slow group, cultured in Whitten's medium. See Figure 5.3 and 5.6 for additional information.

*Peg1/Mest* was expressed in 12 of 15 (80%) of *in vivo*-derived embryos, all of which displayed monoallelic expression from the paternal B6 allele (Figure 5.10). Similar to *in vivo*-derived embryos, both the 6.25 IU and 10 IU groups displayed paternal monoallelic expression, with 20/21 embryos (95%) showing expression from each of the two groups (Figure 5.10).

Imprinted expression of *Peg1/Mest* was evaluated in 14 FF, 8 FS, 9 SF and 8 SS embryos. All embryos displayed paternal monoallelic expression with the exception of the FF group; three embryos lacked any detectable *Peg1/Mest* expression (Figure 5.11). Expression of *Snrpn* was also analyzed in all samples as a control for generation of the cDNA library, and was monoallelically expressed in all samples. Thus, similar to previous experiments with *Snrpn* and *Peg3* (Mann et al., 2004; Market-Velker et al., 2010b), no effect was observed on imprinted expression, even through alteration in imprinted methylation were present in these same embryos.

## **5.4 Discussion**

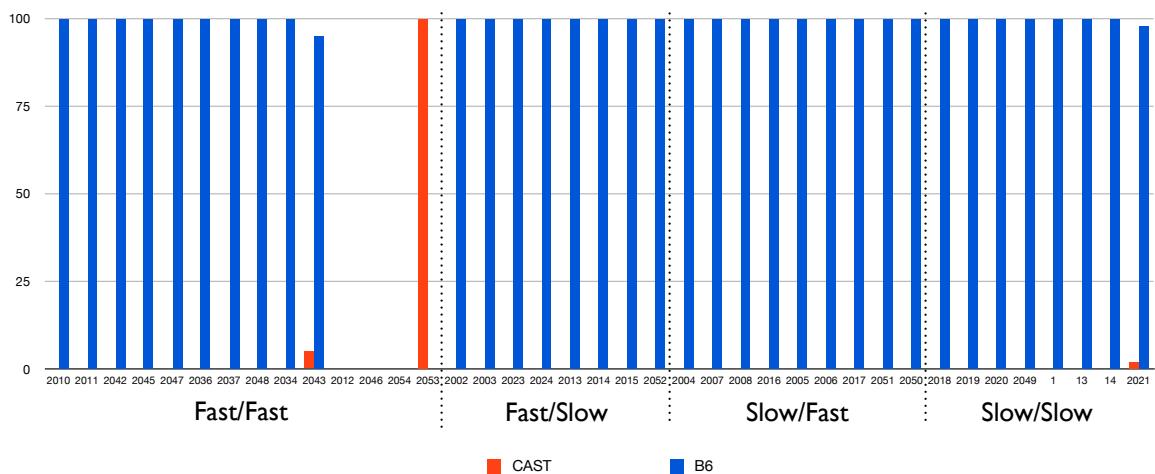
In this study, we present a comprehensive evaluation of the effects of superovulation and *in vitro* culture on genomic imprinting at *Peg1/Mest*. Superovulation resulted in disruption of imprinted methylation at the blastocyst stage, in a dose-dependent manner, similar to other loci previously examined (Chapter 2; Market-Velker et al., 2010a). Our analysis of individual oocytes provides evidence that this disruption was not due to a failure of imprint acquisition during oogenesis, as superovulated oocytes displayed methylation patterns identical to their *in vivo*-derived counterparts. With



**Figure 5.10: Imprinted Expression of *Peg1/Mest* in Spontaneous and Superovulated Blastocysts**

Imprinted expression of *Peg1/Mest* in blastocysts derived from spontaneously ovulated and superovulated females. Green represents the paternal B6 allele, and blue represents the maternal CAST allele. Biallelic expression was classified as > 10% expression from the maternal allele. Embryo designations and groups are indicated on the bottom.





**Figure 5.11: Imprinted Expression of *Peg1/Mest* in Cultured Embryos**

Imprinted expression of *Peg1/Mest* in blastocysts cultured in Whitten’s medium. Green represents the paternal B6 allele, and blue represents the maternal CAST allele. Biallelic expression was classified as  $> 10\%$  expression from the maternal allele. Embryo designations and groups are indicated at the bottom.

respect to embryo culture, no difference was observed in *Peg1/Mest* imprinted methylation between “Fast” and “Slow” embryos, while a significant loss of methylation was observed when compared to *in vivo*-derived controls. This suggests that mechanisms regulating maintenance of genomic imprinting during the early preimplantation stages at the *Peg1/Mest* DMR were not affected by rates of embryo development.

#### **5.4.1 Maintenance, Not Acquisition, is Affected by Superovulation**

We have previously shown that, at the blastocyst stage, superovulation results in loss of imprinted methylation on the repressed maternal allele of *Snrpn*, *Peg3*, and *Kcnq1ot1*, and a gain of methylation on the active maternal *H19* allele. Loss of methylation on the paternal *H19* allele was also observed, which first led us to speculate that superovulation may disrupt maintenance of genomic imprinting, rather than, or in addition to, acquisition. Here, we show that acquisition of genomic imprinting at the *Peg1/Mest* locus was not affected by superovulation, consistent with another study demonstrating normal imprinted methylation at the *Peg1/Mest* DMR in the oocyte following superovulation (Sato et al., 2007). Furthermore, greater loss of methylation in the high hormone group compared to the low dosage group indicates a dose-dependent effect.

In a previous study, imprinted methylation at the *Peg1/Mest* DMR was investigated in fully grown GV oocytes, freshly ovulated MII oocytes, and MII oocytes cultured for either 8 or 24 hours (22 and 42 hours after hCG, respectively), all derived

from superovulated females. *Peg1/Mest* methylation acquisition was completed in MII oocytes following culture for 8 hrs (22 hours post-hCG), but not in earlier stages of oocyte maturation, indicating that acquisition of methylation at this locus continued after ovulation. Our oocytes were collected at approximately 22 hours post-hCG, and fully hypermethylated alleles were observed in both spontaneously and induced ovulated oocytes.

Two theories concerning the effects of superovulation on acquisition of genomic imprints have been put forth. First, hormonal stimulation may lead to rapid oocyte maturation, or it may induce ovulation of immature oocytes that have not completely acquired their imprints (Paoloni-Giacobino and Chaillet, 2004; Ludwig et al., 2005). As we observed no change in oocyte diameter or volume, nor a delay in imprint acquisition, our data indicate that immature oocytes were not recovered in this analysis. Secondly, ovarian stimulation may accelerate oocyte maturation (Baerwald et al., 2009), resulting in an inability of the oocyte to synthesize and store high enough amounts of these maternal factors. In this case, imprint acquisition would proceed normally but imprint maintenance would be compromised during preimplantation development. Our results support the latter hypothesis.

Studies of human oocytes have suggested that acquisition of imprinted methylation is affected by superovulation, however in all of these studies, intrinsic subfertility is a confounding factor. Loss of methylation at the *Peg1/Mest* locus was observed in oocytes collected from infertile women undergoing hormonal stimulation, however mouse oocytes from the same study in which intrinsic subfertility is not a

confounding factor showed no loss of methylation (Sato et al., 2007). Subfertility in male patients has also been associated with alteration at the *Peg1/Mest* locus. The *Peg1/Mest* DMR is unmethylated from fetal spermatogonia to mature spermatozoa (Kerjean et al., 2000). Hypermethylation of this region has been associated with idiopathic male infertility as well as infertility due to low sperm counts (Poplinski et al., 2010). Therefore, although mechanisms in the sperm and in the oocyte vary, alterations of acquisition of genomic imprinting observed in human studies at the *Peg1/Mest* locus may be a result of intrinsic subfertility of the patient, and not only a result of hormonal stimulation.

#### **5.4.2 *In Vitro* Culture, but not Rates of Early Development Affect Methylation of *Peg1/Mest***

Embryo culture has been shown to cause perturbation of imprinted methylation and expression of a number of imprinted genes (Doherty et al., 2000; Mann et al., 2004; Rivera et al., 2008; Market-Velker et al., 2010b). Consistent with data from the previous chapters, here we report loss of imprinted methylation at the *Peg1/Mest* DMR following *in vitro* culture to the blastocyst stage in Whitten's medium. This is in contrast to two other studies which show no loss of methylation at the 2-cell or blastocyst stage following *in vitro* culture in M16 medium (Imamura et al., 2005), or M16 medium supplemented with serum (Khosla et al., 2001). However neither of these were performed allelically, or on individual embryos.

Moreover, we separated *in vitro* cultured embryos into groups based on their rates of preimplantation development, as previously described in Chapter 4. Contrary to our previous observations, where loss of methylation was more severe in the “Fast” group at the *H19* and *Snrpn* ICRs, loss of methylation at the *Peg1/Mest* DMR was not different between “Fast” and “Slow” embryos. Therefore, unlike *Snrpn* and *H19*, methylation at the *Peg1/Mest* DMR does not correlate with rates of early cleavage.

This difference could be due to a number of factors. First, the regions of *H19* and *Snrpn* analyzed in our previous study were known imprinting control regions (ICRs), while the region of *Peg1/Mest* analyzed in this study consisted of 15 CpGs within the known DMR. Until this DMR is investigated for its ability to regulate domain imprinting, it is not certain whether this region represents the *Peg1/Mest* ICR. Once identified, analysis of the *Peg1/Mest* ICR may show a similar association with rates of embryo development as do *Snrpn* and *H19*.

Alternatively, many other groups have described a differential response of *Peg1/Mest* to environmental insult when compared to other imprinted loci (Khosla et al., 2001; Liang et al., 2008; Tveden-Nyborg et al., 2008; Anckaert et al., 2010), suggesting that slightly different mechanisms regulate genomic imprinting at this locus. Different mechanisms operating at these imprinted loci during early cleavage stages would explain the altered susceptibility of *Peg1/Mest* to the differences between “Fast” and “Slow” embryos at early stages of preimplantation development.

Furthermore, the *Peg1/Mest* locus was not protected from the detrimental effects of long term *in vitro* culture. We observed a significant increase in the number of cultured

embryos displaying loss of imprinted methylation when compared to *in vivo*-derived controls. Due to the late acquisition of methylation in the oocyte, slow rates of development may not confer the same advantage to oocytes' ability to maintain levels of methylation at the *Peg1/Mest* locus early in preimplantation development, as it had for *H19* and *Snrpn*. Thus, a persistent suboptimal culture environment, together with later acquisition of *Peg1/Mest* methylation, would result in de-regulation of factors necessary throughout subsequent cell cycles for maintenance of genomic imprinting.

#### **5.4.4 Imprinted Expression of *Peg1/Mest* is Unaffected by Superovulation, and Embryo Culture**

In addition to imprinted methylation, we examined *Peg1/Mest* imprinted expression in blastocysts derived from superovulated females, as well as those subjected to *in vitro* culture. Neither procedure affected imprinted expression of *Peg1/Mest*. Previous studies have shown disrupted imprinted expression of *H19* following embryo manipulation (Doherty et al., 2000; Mann et al., 2004; Market-Velker et al., 2010b), however, no change in imprinted expression was observed for *Snrpn*, and *Peg3* under the same conditions at the blastocyst stage (Doherty et al., 2000; Market-Velker et al., 2010b). Having said this, analysis of imprinted expression at post-implantation stages of these same genes revealed biallelic expression, especially in extraembryonic tissues (Mann et al., 2004; Rivera et al., 2008). Thus, we predict that *Peg1/Mest* will behave in a similar manner with disruption of imprint methylation maintenance during

preimplantation development resulting in dysregulation of imprinted expression in post-implantation tissues.

To date, many groups have attempted to characterize the changes in expression (Wang et al., 2005; Zheng et al., 2005; Hamatani et al., 2006; Zheng et al., 2007; Giritharan et al., 2010), and in localization of chromatin modifiers (Doherty et al., 2000; Ooga et al., 2008; Kim and Ogura, 2009) throughout normal preimplantation development, and in response to different ARTs. These studies, and others specifically targeting known regulators of epigenetic phenomena will be invaluable in pinpointing the specific factors involved in global maintenance of genomic imprinting during preimplantation development. Our data suggest that investigation of epigenetic factors that are produced as maternal effect products may hold the most promise for identifying those factors involved in imprinted maintenance during preimplantation development.

## 5.5 References

- Anckaert, E., Romero, S., Adriaenssens, T. and Smitz, J. (2010) 'Effects of low methyl donor levels in culture medium during mouse follicle culture on oocyte imprinting establishment', *Biol Reprod* 83(3): 377-86.
- Bressan, F. F., De Bem, T. H., Perecin, F., Lopes, F. L., Ambrosio, C. E., Meirelles, F. V. and Miglino, M. A. (2009) 'Unearthing the roles of imprinted genes in the placenta', *Placenta* 30(10): 823-34.
- Broad, K. D., Curley, J. P. and Keverne, E. B. (2009) 'Increased apoptosis during neonatal brain development underlies the adult behavioral deficits seen in mice lacking a functional paternally expressed gene 3 (Peg3)', *Dev Neurobiol* 69(5): 314-25.
- Chou, Y. Y., Chen, C. C., Kuo, P. L., Tsai, W. H. and Lin, S. J. (2004) 'Russell-Silver syndrome: molecular diagnosis of maternal uniparental disomy of chromosome 7 using methylation-specific polymerase chain reaction assay and single nucleotide polymorphisms genotyping', *J Formos Med Assoc* 103(10): 797-802.
- Doherty, A. S., Mann, M. R., Tremblay, K. D., Bartolomei, M. S. and Schultz, R. M. (2000) 'Differential effects of culture on imprinted H19 expression in the preimplantation mouse embryo', *Biol Reprod* 62(6): 1526-35.
- Eggermann, T., Spengler, S., Bachmann, N., Baudis, M., Mau-Holzmann, U. A., Singer, S. and Rossier, E. (2010) 'Chromosome 11p15 duplication in Silver-Russell syndrome due to a maternally inherited translocation t(11;15)', *Am J Med Genet A* 152A(6): 1484-7.
- Feil, R., Khosla, S., Cappai, P. and Loi, P. (1998) 'Genomic imprinting in ruminants: allele-specific gene expression in parthenogenetic sheep', *Mamm Genome* 9(10): 831-4.
- Giritharan, G., Li, M. W., De Sebastiano, F., Esteban, F. J., Horcajadas, J. A., Lloyd, K. C., Donjacour, A., Maltepe, E. and Rinaudo, P. F. (2010) 'Effect of ICSI on gene expression and development of mouse preimplantation embryos', *Hum Reprod* 25(12): 3012-24.
- Hamatani, T., Ko, M., Yamada, M., Kuji, N., Mizusawa, Y., Shoji, M., Hada, T., Asada, H., Maruyama, T. and Yoshimura, Y. (2006) 'Global gene expression profiling of preimplantation embryos', *Hum Cell* 19(3): 98-117.
- Hannula, K., Lipsanen-Nyman, M., Kontiokari, T. and Kere, J. (2001) 'A narrow segment of maternal uniparental disomy of chromosome 7q31-qter in Silver-Russell syndrome delimits a candidate gene region', *Am J Hum Genet* 68(1): 247-53.
- Hiura, H., Obata, Y., Komiyama, J., Shirai, M. and Kono, T. (2006) 'Oocyte growth-dependent progression of maternal imprinting in mice', *Genes Cells* 11(4): 353-61.
- Imamura, T., Kerjean, A., Heams, T., Kupiec, J. J., Thenevin, C. and Paldi, A. (2005) 'Dynamic CpG and non-CpG methylation of the Peg1/Mest gene in the mouse oocyte and preimplantation embryo', *J Biol Chem* 280(20): 20171-5.
- Kagami, M., Nagai, T., Fukami, M., Yamazawa, K. and Ogata, T. (2007) 'Silver-Russell syndrome in a girl born after in vitro fertilization: partial hypermethylation at the



- differentially methylated region of PEG1/MEST', *J Assist Reprod Genet* 24(4): 131-6.
- Kaneko-Ishino, T., Kuroiwa, Y., Miyoshi, N., Kohda, T., Suzuki, R., Yokoyama, M., Viville, S., Barton, S. C., Ishino, F. and Surani, M. A. (1995) 'Peg1/Mest imprinted gene on chromosome 6 identified by cDNA subtraction hybridization', *Nat Genet* 11(1): 52-9.
- Kerjean, A., Dupont, J. M., Vasseur, C., Le Tessier, D., Cuisset, L., Paldi, A., Jouannet, P. and Jeanpierre, M. (2000) 'Establishment of the paternal methylation imprint of the human H19 and MEST/PEG1 genes during spermatogenesis', *Hum Mol Genet* 9(14): 2183-7.
- Khosla, S., Dean, W., Brown, D., Reik, W. and Feil, R. (2001) 'Culture of preimplantation mouse embryos affects fetal development and the expression of imprinted genes', *Biol Reprod* 64(3): 918-26.
- Kim, J. M. and Ogura, A. (2009) 'Changes in allele-specific association of histone modifications at the imprinting control regions during mouse preimplantation development', *Genesis* 47(9): 611-6.
- Kobayashi, S., Kohda, T., Miyoshi, N., Kuroiwa, Y., Aisaka, K., Tsutsumi, O., Kaneko-Ishino, T. and Ishino, F. (1997) 'Human PEG1/MEST, an imprinted gene on chromosome 7', *Hum Mol Genet* 6(5): 781-6.
- Kotzot, D., Schmitt, S., Bernasconi, F., Robinson, W. P., Lurie, I. W., Ilyina, H., Mehes, K., Hamel, B. C., Otten, B. J., Hergersberg, M. et al. (1995) 'Uniparental disomy 7 in Silver-Russell syndrome and primordial growth retardation', *Hum Mol Genet* 4(4): 583-7.
- Lefebvre, L., Viville, S., Barton, S. C., Ishino, F., Keverne, E. B. and Surani, M. A. (1998) 'Abnormal maternal behaviour and growth retardation associated with loss of the imprinted gene Mest', *Nat Genet* 20(2): 163-9.
- Liang, X. W., Zhu, J. Q., Miao, Y. L., Liu, J. H., Wei, L., Lu, S. S., Hou, Y., Schatten, H., Lu, K. H. and Sun, Q. Y. (2008) 'Loss of methylation imprint of Snrpn in postovulatory aging mouse oocyte', *Biochem Biophys Res Commun* 371(1): 16-21.
- Mann, M. R., Lee, S. S., Doherty, A. S., Verona, R. I., Nolen, L. D., Schultz, R. M. and Bartolomei, M. S. (2004) 'Selective loss of imprinting in the placenta following preimplantation development in culture', *Development* 131(15): 3727-35.
- Market-Velker, B. A., Fernandes, A. D. and Mann, M. R. (2010b) 'Side-by-side comparison of five commercial media systems in a mouse model: suboptimal in vitro culture interferes with imprint maintenance', *Biol Reprod* 83(6): 938-50.
- Market-Velker, B. A., Zhang, L., Magri, L. S., Bonvissuto, A. C. and Mann, M. R. (2010a) 'Dual effects of superovulation: loss of maternal and paternal imprinted methylation in a dose-dependent manner', *Hum Mol Genet* 19(1): 36-51.
- Morison, I. M., Ramsay, J. P. and Spencer, H. G. (2005) 'A census of mammalian imprinting', *Trends Genet* 21(8): 457-65.
- Nishita, Y., Sado, T., Yoshida, I. and Takagi, N. (1999) 'Effect of CpG methylation on expression of the mouse imprinted gene Mest', *Gene* 226(2): 199-209.

- Obata, Y. and Kono, T. (2002) 'Maternal primary imprinting is established at a specific time for each gene throughout oocyte growth', *J Biol Chem* 277(7): 5285-9.
- Ono, R., Nakamura, K., Inoue, K., Naruse, M., Usami, T., Wakisaka-Saito, N., Hino, T., Suzuki-Migishima, R., Ogonuki, N., Miki, H. et al. (2006) 'Deletion of Peg10, an imprinted gene acquired from a retrotransposon, causes early embryonic lethality', *Nat Genet* 38(1): 101-6.
- Ooga, M., Inoue, A., Kageyama, S., Akiyama, T., Nagata, M. and Aoki, F. (2008) 'Changes in H3K79 methylation during preimplantation development in mice', *Biol Reprod* 78(3): 413-24.
- Poplinski, A., Tuttelmann, F., Kanber, D., Horsthemke, B. and Gromoll, J. (2010) 'Idiopathic male infertility is strongly associated with aberrant methylation of MEST and IGF2/H19 ICR1', *Int J Androl* 33(4): 642-9.
- Reik, W. and Walter, J. (2001) 'Genomic imprinting: parental influence on the genome', *Nat Rev Genet* 2(1): 21-32.
- Reule, M., Krause, R., Hemberger, M. and Fundele, R. (1998) 'Analysis of Peg1/Mest imprinting in the mouse', *Dev Genes Evol* 208(3): 161-3.
- Riesewijk, A. M., Hu, L., Schulz, U., Tariverdian, G., Hoglund, P., Kere, J., Ropers, H. H. and Kalscheuer, V. M. (1997) 'Monoallelic expression of human PEG1/MEST is paralleled by parent-specific methylation in fetuses', *Genomics* 42(2): 236-44.
- Rivera, R. M., Stein, P., Weaver, J. R., Mager, J., Schultz, R. M. and Bartolomei, M. S. (2008) 'Manipulations of mouse embryos prior to implantation result in aberrant expression of imprinted genes on day 9.5 of development', *Hum Mol Genet* 17(1): 1-14.
- Rodenhiser, D. and Mann, M. (2006) 'Epigenetics and human disease: translating basic biology into clinical applications', *CMAJ* 174(3): 341-8.
- Sato, A., Otsu, E., Negishi, H., Utsunomiya, T. and Arima, T. (2007) 'Aberrant DNA methylation of imprinted loci in superovulated oocytes', *Hum Reprod* 22(1): 26-35.
- Suzuki, S., Renfree, M. B., Pask, A. J., Shaw, G., Kobayashi, S., Kohda, T., Kaneko-Ishino, T. and Ishino, F. (2005) 'Genomic imprinting of IGF2, p57(KIP2) and PEG1/MEST in a marsupial, the tammar wallaby', *Mech Dev* 122(2): 213-22.
- Takahashi, M., Kamei, Y. and Ezaki, O. (2005) 'Mest/Peg1 imprinted gene enlarges adipocytes and is a marker of adipocyte size', *Am J Physiol Endocrinol Metab* 288(1): E117-24.
- Tveden-Nyborg, P. Y., Alexopoulos, N. I., Cooney, M. A., French, A. J., Tecirlioglu, R. T., Holland, M. K., Thomsen, P. D. and D'Cruz, N. T. (2008) 'Analysis of the expression of putatively imprinted genes in bovine peri-implantation embryos', *Theriogenology* 70(7): 1119-28.
- Varrault, A., Gueydan, C., Delalbre, A., Bellmann, A., Houssami, S., Akin, C., Severac, D., Chotard, L., Kahli, M., Le Digarcher, A. et al. (2006) 'Zac1 regulates an imprinted gene network critically involved in the control of embryonic growth', *Dev Cell* 11(5): 711-22.

- Wang, S., Cowan, C. A., Chipperfield, H. and Powers, R. D. (2005) 'Gene expression in the preimplantation embryo: in-vitro developmental changes', *Reprod Biomed Online* 10(5): 607-16.
- Wilkinson, L. S., Davies, W. and Isles, A. R. (2007) 'Genomic imprinting effects on brain development and function', *Nat Rev Neurosci* 8(11): 832-43.
- Wollmann, H. A., Kirchner, T., Enders, H., Preece, M. A. and Ranke, M. B. (1995) 'Growth and symptoms in Silver-Russell syndrome: review on the basis of 386 patients', *Eur J Pediatr* 154(12): 958-68.
- Zheng, P., Schramm, R. D. and Latham, K. E. (2005) 'Developmental regulation and in vitro culture effects on expression of DNA repair and cell cycle checkpoint control genes in rhesus monkey oocytes and embryos', *Biol Reprod* 72(6): 1359-69.
- Zheng, P., Vassena, R. and Latham, K. E. (2007) 'Effects of in vitro oocyte maturation and embryo culture on the expression of glucose transporters, glucose metabolism and insulin signaling genes in rhesus monkey oocytes and preimplantation embryos', *Mol Hum Reprod* 13(6): 361-71.

## **Chapter 6 - Discussion**

Genomic imprinting is a complex process that depends on both the proper acquisition and maintenance of imprinting marks throughout preimplantation development, and adult life. Assisted reproductive technologies, namely superovulation and embryo culture, take place during the critical periods of imprint acquisition and maintenance, providing an window for deregulation of these processes. To date, our ability to investigate the effects of ARTs on embryos has been limited by our technical abilities. To properly evaluate the effects at a level relevant to the human clinic studies must be performed on individual embryos, to obtain information about the degree of perturbation in each embryo, as well as the frequency of perturbation under each environmental condition. The methodology developed (outlined in Appendix 1) represents a technical advancement in the field. Prior to the experiments in this thesis, the effects of ARTs were known only for a select number of imprinted loci, from studies using pools of embryos, and investigations of individual embryos at post-implantation stages of development. Here, I provide a comprehensive analysis of ART-induced imprinting errors at the single embryo level, in preimplantation embryos. Experiments investigate the effects of superovulation alone and of culture alone in various commercially-available media, on both imprinted methylation and expression at key loci. In addition, as this has not been previously investigated, I report the effects of embryo culture on *Peg3* and *Kcnq1ot1* at the blastocyst stage, and comprehensive evaluation of the response of the *Peg1/Mest* locus to ARTs.

In addition, these studies aim to provide some insight into the mechanism of imprinting dysregulation. Much work remains to be done before distinct molecular pathways are elucidated, however the work presented in this thesis narrows the search: (1) both maternal and paternal imprints are disrupted by superovulation, indicating that superovulation perturbs a maternal-effect gene product required for imprint maintenance during preimplantation development; (2) multiple imprinted loci are affected in the same embryo by ARTs, although the misregulated loci vary between embryos, indicating that the response to adverse effects of ARTs is stochastic; (3) the use of multiple procedures increases the number of affected embryos, suggesting that pathways disrupted by various ARTs are the same, or converge at common point; and (4) faster developing embryos exhibited a greater loss of imprinting, greater changes in metabolic activity and are least similar to *in vivo*-derived controls, suggesting that higher metabolic levels and faster cell cycle divisions represent maladaptations to the culture environment.

## **6.1 ARTs Affect Genomic Imprinting**

### **6.1.1 Superovulation**

The timing of superovulation coincides with the development of oocytes from MI to arrested MII, when the acquisition of methylation imprints occurs. Due to this timing, we and others have hypothesized that superovulation disrupts the acquisition of genomic imprints. Therefore, any disruption in genomic imprinting that occurred as a result of

superovulation would be evident at the MII stage, and after fertilization and preimplantation development, would be present at blastocyst stage. As well, only maternal imprints should be affected, as the paternal imprint is acquired in developing spermatocytes and would not be affected by hormonal treatment used for superovulation.

A number of hypotheses attempt to explain how superovulation disrupts imprint acquisition. The first suggests that superovulation rescues subordinate follicles that, under normal circumstances, would undergo atresia and not develop into fully mature oocytes (Van der Auwera and D'Hooghe, 2001). Superovulated oocytes override the atretic program, leading to ovulation of oocytes that have not properly acquired their maternal imprints. Variations on this hypothesis state that superovulation simply results in ovulation of immature oocytes that have not had enough time to acquire their genomic imprints (Paoloni-Giacobino and Chaillet, 2004; Ludwig et al., 2005). In both of these cases, superovulation does not affect epigenetic processes in the oocyte, it simply allows continued development of oocytes with aberrant genomic imprinting, or accelerates development preventing completion of acquisition prior to ovulation. The second hypothesis suggests that administration of exogenous hormones results in modulation of molecular signaling pathways. These molecular pathways may result in misregulation of genes important for acquisition of genomic imprinting (ex: DNMT and its binding partners), perhaps disrupting the ability of the cell to target epigenetic machinery to proper locations resulting in lack of *de novo* methylation at certain loci. This would result in disruption of methylation acquisition at maternally methylated loci, and potentially, in a gain of methylation of paternally methylated (maternally unmethylated) loci if

mechanisms blocking methylation at a given locus were also disrupted. However, this hypothesis does not provide an explanation for loss of methylation at paternally-inherited loci, that acquire their methylation in male germ cells. The third hypothesis states that superovulation accelerates the growth rate of ovarian follicles, allowing for normal maternal imprint acquisition, but instead disrupts one or more maternal-effect genes or gene products. This maternal-effect gene would play a key role in maintenance of genomic imprinting throughout preimplantation development. Experiments in this thesis support the third hypothesis, as no change in *Peg1/Mest* imprint acquisition was observed following superovulation. In addition, superovulation resulted in loss of methylation on maternal alleles, gain of methylation on maternal alleles, and most importantly, loss of methylation on paternal alleles, in blastocyst stage embryos.

Further evidence has begun to support the third hypothesis. Other groups have reported no adverse effects of superovulation on maternal imprinted methylation in oocytes; fully methylated alleles are noted at imprinted loci (Sato et al., 2007; Anckaert et al., 2009). Studies from our lab (by M. Denomme) confirm this; following superovulation, fully methylated maternal alleles are observed in MII oocytes.

Therefore, I propose that superovulation acts to disrupt genomic imprinting potentially through acceleration of ovarian follicle growth leading to disruption of one or more maternal-effect genes or gene products. This accelerated growth may result in a decrease in maternal mRNA stores, which are critical for maintenance of genomic imprinting. A decrease in these stores would not affect acquisition of genomic imprinting, as the molecular components necessary for this transient act of *de novo* methylation (and

potentially histone modifications, etc...) would be synthesized prior to their function during the arrested MI to MII period, and are not required to exhibit long-term activity. However, the level of maternal mRNAs necessary for maintenance may fall below a necessary threshold to maintain imprinting at certain loci. As such, maintenance of maternal methylation would be affected, causing levels of maternal methylation to decline. In addition, mechanisms that protect paternally methylated loci from acquiring a maternal profile would also be depleted, accounting for the gain of methylation that we and others (Borghol et al., 2006; Sato et al., 2007) have observed following superovulation. Finally, it would be expected that these same maternal mRNAs would be required to maintain imprinted marks during the drastic epigenetic changes undergone by the paternal genome following fertilization. As such, a deficiency in these factors may result in disruption of paternal imprints during the active wave of demethylation after fertilization, consistent with our report of loss of paternal methylation at the *H19* allele in blastocysts following superovulation. With the model outlined above, loss of methylation on the maternal alleles of paternally expressed genes, gain of methylation on the paternal alleles of maternally expressed genes, as well as loss of methylation on the paternal allele of maternally expressed genes is expected, all of which I report in Chapters 2-5.

### **6.1.2 Embryo Culture**

The second ART investigated was embryo culture. Depending on the protocol employed, embryo culture takes place from the 1- or 2-cell stage, up to the 4- to 8-cell, or



blastocyst stage. Many studies have identified ARTs, of which embryo culture is an integral component, as a means to disrupt genomic imprinting, however the majority of studies did not evaluate embryo culture alone (Doherty et al., 2000; Khosla et al., 2001; Mann et al., 2004; Li et al., 2005; Fauque et al., 2007). As such, separating out the effects of each individual technique using these studies is nearly impossible. Our studies focused on embryo culture alone, demonstrating a significant effect on genomic imprint maintenance.

Comparisons of studies of embryo culture have proven difficult as type of culture media, type of oil overlay, culture volume, oxygen tension, and associated ARTs, to name only a few, vary between labs and clinics. In Chapter 3, I aimed to accurately compare multiple embryo culture media currently used in the field and determine if one media was superior to another with respect to the maintenance of genomic imprinting. Contrary to my expectations, I did not observe drastic differences between media; all media were suboptimal in their ability to maintain genomic imprinting. However, genomic imprinting at certain loci was better maintained in some media than others. Overall more recently developed media (ex: Global) appeared superior to the less optimized types (ex; HTF and Whitten's). As well, the use of sequential media showed no advantage over non-sequential media. These findings lead us to speculate that embryo culture, the act of maintaining preimplantation embryos out of the female reproductive tract, is the most significant factor. In addition, as all loci were affected by all media, I speculate that the factor(s) that is affected by embryo culture is a universal one, and the mechanism underlying the dysregulation is a global mechanism rather than a locus specific binding

factor. Differences in embryo culture media are then due to the degree of perturbation of these factors, and to the extent of compensatory mechanisms in each embryo.

One candidate through which global methylation may be affected is DNMT1. Two isoforms of DNMT1 have been described in preimplantation stage embryos, the somatic form DNMT1s, and the oocyte-specific form DNMT1o (Ding and Chaillet, 2002). During preimplantation development, DNMT1s is localized predominantly to the cytoplasm, (Carlson et al., 1992), while DNMT1o localizes to the nucleus at the 8-cell stage (Ding and Chaillet, 2002). Disruptions in DNMT1 itself are unlikely, as a number of imprinted genes in the embryo and placenta do not appear to require DNMT1 for monoallelic expression (Li et al., 1993; Caspary et al., 1998; Lewis et al., 2004), those that do vary in their response to reduced levels of DNMT1 (Weaver et al., 2010) and no differences in DNMT1 localization or activity have been noted following embryo culture (Doherty et al., 2000).

The passive demethylation of the maternal genome suggests that although DNMT1 is present in the nucleus during preimplantation stages, its activity is tightly regulated and targeted to DMRs. Some studies have suggested that this targeting mechanism may involve *Zfp57*, a DNA binding protein that recruits the histone methylase complex SETDB1, which provides repressive histone marks (Ayyanathan et al., 2003), or *Stella*, another similar histone modification targeting factor (Nakamura et al., 2007). Histone methylation may provide binding sites for proteins such as HP1, which in turn can recruit DNMTs (Lehnertz et al., 2003). Disruption in one or many of these targeting

mechanisms, or their associated protein complexes, may be cause of the loss of methylation that we and others have observed at the blastocyst stage.

Imprinted loci may not be the only regions disrupted by ARTs. Many studies have shown global changes in epigenetic modifications following embryo culture. The effect of assisted reproduction on DNA methylation was assessed at more than 700 genes in placenta and cord blood from children of assisted and unassisted conceptions using a site-specific CpG methylation assay (Katari et al., 2009). A significant change in DNA methylation was observed with lower mean methylation levels in the placenta, and higher mean methylation levels in cord blood from children conceived *in vitro* when compared to children conceived naturally, indicating the broad effects of ART on DNA methylation. Global changes in genes involved in glucose metabolism, glucose transporters and insulin signaling (Zheng et al., 2007), and changes in genes involved in DNA repair, and cell cycle regulation (Zheng et al., 2005) have been shown following embryo culture, again indicating that embryo culture has the potential to affect many different cellular systems.

In addition, we cannot rule out the possibility that mechanisms regulating individual loci are also disrupted by ARTs. As different imprinted loci are regulated through different mechanisms (Wan and Bartolomei, 2008; Koerner et al., 2009), with different domain specific proteins involved in their acquisition and maintenance, it is possible that a common factor involved in the regulation of some, but not all, imprinted loci, is dysregulated by ARTs.

### **6.1.3 Multiple ARTs**

The effects of multiple ARTs is additive, resulting in more embryos with disruptions at more imprinted loci. Examination of different loci did not reveal gene-specific, nor ART type-specific effects, as one locus was not more likely to show loss of methylation in one media type, or following one type of ART than another locus. This suggests that superovulation and genomic imprinting affect the same epigenetic pathways, or that their effects converge on a single pathway. While one technique may result in some depletion or overexpression of important factors, the use of multiple ARTs exacerbates this effect leading to more affected embryos. My data indicates that superovulation results in depletion of maternal mRNA used for maintenance of genomic imprinting. Embryo culture may result in perturbation of the same oocyte-specific mRNA(s) if it persists through early cleavage division or the same gene(s) if it is also transcribed from the embryonic genome.

### **6.2 Stochastic Effects of ARTs**

The first studies to identify perturbations of genomic imprinting were performed on pools of embryos (Sasaki et al., 1995; Doherty et al., 2000). While these studies were integral to uncovering the fact that *in vitro* culture caused dysregulation of genomic imprinting, they were unable to provide specific information about the frequency and

severity of this dysregulation. Development and utilization of single embryo protocols (Appendix 1) was necessary to obtain this information.

One common finding from these experiments is the stochastic nature of imprint disruption by superovulation and embryo culture. In the case of superovulation, some embryos were severely affected at a given locus, showing very low levels of imprinted methylation, while others showed no loss of methylation at that same locus with levels of imprinted methylation comparable to *in vivo*-derived embryos. In addition, embryos displaying severe loss of imprinted methylation at one locus did not necessarily show loss at other imprinted loci, and no consistent patterns emerged. This indicates that the effects of superovulation are not locus specific, supporting the idea that more global epigenetic mechanisms are disrupted.

In the case of embryo culture, the same phenomenon was observed. Loss of methylation was observed in some, but not all embryos, and at some, but not all loci. In those embryos that remained unaffected at all the loci examined, further analysis of additional imprinted loci would likely reveal that genomic imprinting is affected in every embryo, while the extent of the disruption varies with different embryo manipulations. The question then becomes what differentiates those embryos that better maintain genomic imprinting from those that do not.

To shed light on this phenomenon, I investigated the relationship between rates of preimplantation development and genomic imprinting. We attempted to determine if there were non-invasive characteristics that would lead us to predict which embryos would be more severely affected by embryo culture, and which were more similar to *in*

*vivo*-derived control embryos. This question has significant importance to the selection of embryos for transfer in the human clinic. Often a number of oocytes are fertilized and become viable embryos, but how to choose the best embryo(s) to transfer to the patient is often unclear. Morphological staging and assessment are commonly used, with fast development most often equated with the healthiest embryos (Claman et al., 1987; Shoukir et al., 1997; Van Montfoort et al., 2004; Windt et al., 2004; Biezinova et al., 2006). Here, I argue against the use of the fastest developing embryos, supporting other studies in humans suggesting that a slow to moderate rate of development (neither too slow, nor too fast) is a marker of embryo health (Cummins et al., 1986; Alikani et al., 2000; Weitzman et al., 2010).

### **6.3 The Mouse Model and Application to the Human Clinic**

There are many barriers to a thorough evaluation of ARTs, including the ethical dilemma of using human embryos and the difficulties with long term follow up, to name a few. As such, our studies were carried out using the mouse model system, as the protocols employed for superovulation and embryo retrieval are simple, standardized procedures. In addition, the mouse embryo has been historically used to optimize culture conditions for the human embryo and is still used as a quality control assay for every batch of embryo culture media. The mouse is still advocated as the model system of choice for studies of early embryo development and its molecular regulation (Quinn and Horstman, 1998; Summers and Biggers, 2003). Studies using the mouse model have been

integral in the development and refinement of various ARTs, and in the future, thorough evaluation of new techniques in animal model systems such as the mouse should be undertaken prior to widespread acceptance and use of these new techniques in humans.

While the immediate applicability of these studies to the human clinic may be debated, from the data presented in this thesis I am able to make a number of general recommendations with respect to the manipulation of preimplantation stage embryos. First, the number and prolonged use of ARTs should be minimized, as I have shown that the effects of multiple ARTs are additive. Avoidance of superovulation through single embryo transfer techniques is one way to minimize ARTs that can be put into practice immediately. Secondly, if multiple embryos are available for transfer, those displaying moderate rates of development should be chosen over those with very fast, or very slow rates of development. Third, as we showed no advantage of sequential media over non-sequential medium with respect to genomic imprinting, my data advocate the use of non-sequential media to avoid additional embryo manipulation occurring with transfer of embryos to different culture drops. Fourth, all embryos are affected by manipulation during ARTs, however some are affected more than others. Patients undergoing ART should be made aware of this fact, and more patient education outlining the risks of ART should be instituted. Most importantly, findings from these and other studies indicate that it is possible to generate blastocysts that appear morphologically normal, but are in reality severely epigenetically compromised.

## **6.4 Future Directions**

From these and other studies, it is evident that ARTs, in their many forms, perturb genomic imprinting at multiple loci. The next step is to determine ways to prevent these perturbations from occurring, or develop ways to correct them. These objectives can only be carried out once the mechanisms responsible for imprinting acquisition and maintenance are known, and how the environmental insult of ARTs affects these mechanisms. Therefore, future studies in the field should focus on elucidating these pathways, and developing non-invasive ways to detect these mal-adaptations to environmental insult. In addition, studies should focus on moving the knowledge obtained from animal studies to the human clinic.

### **6.4.1 Superovulation**

To confirm the hypothesis of disruption of the maintenance of genomic imprinting, imprinted methylation at multiple loci (those that acquire methylation early as well as those that acquire it later on in oocyte development) in individual embryos throughout the various stages of preimplantation development is required. These studies will determine when loss of methylation occurs, and if the loss is progressive over the entire course of preimplantation development. Pinpointing the stage of preimplantation development at which methylation imprints are lost will provide important insight into the mechanism of this disruption.



Essential to future studies will be the identification of the maternal-effect gene(s) disrupted by superovulation. Maternal-effect genes are transcribed and accumulate in the growing oocyte (Schultz, 1993), and are necessary for the early stages of preimplantation development prior to embryonic genome activation (Flach et al., 1982; Conover et al., 1991; Bellier et al., 1997). A maternal effect on early development has been well described in *Xenopus* (Droin, 1992) and *Drosophila* (Akam, 1987; Morisato and Anderson, 1995) and many maternal-effect genes have also been identified in the mouse, including *Mater* (Tong et al., 2000; Tong et al., 2002), *Zar1* (Wu et al., 2003), *Hsf1* (Christians et al., 2000), *Gdf9* (Dong et al., 1996), *Ces5* (Tashiro et al., 2010) *Filia* (Zheng and Dean, 2009) and *Stella* (Payer et al., 2003).

The maternal-effect gene(s) involved in the effects of superovulation should exhibit a number of characteristics. First, as with other maternal-effect genes, it should be transcribed and stored in the developing oocyte. Mutation or deletion may or may not lead to arrest prior to embryonic genome activation, as uniparental embryos (parthenotes, androgenotes, gynogenotes), which lack a parental genome complement, are able to develop past the 2-cell stage (Markert, 1982; McGrath and Solter, 1984; Surani et al., 1984). This gene should have a known role in epigenetic regulation, and levels, localization or post-translational modification of this gene product should be altered by superovulation.

Therefore, to identify our maternal-effect gene(s), first, a list of genes expressed and stored in the developing oocyte is needed. From this list, genes involved in epigenetic regulation should be identified, generating an list of epigenetic-specific

maternal-effect genes. Final candidates would be those genes displaying differential expression, localization or post-translational modification between spontaneous and superovulated oocytes. Attractive candidates are maternal-effect genes whose functions in epigenetic regulation are well known such as *Stella* (Nakamura et al., 2007), and *Zpf57* (Li et al., 2008), indicated above as potential targeting mechanisms for DNMT1 in preimplantation embryos (Ayyanathan et al., 2003) (Nakamura et al., 2007).

Investigation of global levels of transcription in oocytes and preimplantation embryos has been performed, and a subset of genes have been identified that demonstrate distinct expression patterns (Hamatani et al., 2004; Wang et al., 2004; Zeng et al., 2004; Hamatani et al., 2006). Following embryonic genome activation, maternal mRNAs expressed in the oocyte may either persist with no reactivation from the embryonic genome, or be degraded. Those that show degradation of maternal mRNA may (1) be reactivated in the embryonic genome, or (2) maternal transcripts may be degraded without reactivation. Genes transcribed in the oocyte may also (3) be degraded early in development but be reactivated later, creating a window where no gene product is present in the early embryo. As I hypothesize that the maternal-effect gene(s) of interest is likely involved in the maintenance of genomic imprinting throughout preimplantation development, it is likely that it would be present in the oocyte and in the preimplantation embryo. Arguments can be made as to whether expression originates from the oocyte, and maternal mRNAs persist throughout preimplantation development, or whether maternal mRNAs are degraded and reactivated from the embryonic genome. Both are plausible explanations, however as both superovulation and embryo culture appear to

affect the same pathway, I hypothesize the the gene(s) of interest do display degradation of maternal mRNA and reactivation from the embryonic genome, and therefore follow the first pattern of expression. In the study by Hamatani et al, genes demonstrating degradation followed by an early pattern of reactivation of expression include *Oct4*, *E-cadherin*, *Dnmt1*, *Dnmt2*, *Dnmt3b*, *Lefty2*, *Spp1*, *Mecp2*, *Cbx1*, *Morf4l1*, *Tex20*, *Fragilis*, *Pelo* and *Sfrs3* (Hamatani et al., 2004). Many of these genes, including *Dnmt1*, *Dnmt2*, *Dnmt3b*, *Mecp2*, *Morf4l1*, and *Cbx1* are known to be involved in epigenetic regulation (Aagaard et al., 1999; Nakao et al., 2001; Pardo et al., 2002; Turek-Plewa and Jagodzinski, 2005), and therefore satisfy two of the three criteria of our maternal-effect gene, as outlined above. Demonstration of differences in the levels, localization or post-translational modifications of these gene products in spontaneous and superovulated embryos would fulfill the additional criterion.

Alternatively, the reverse approach could be taken, using genome-wide comparison of expression between spontaneous and superovulated oocytes. Candidates could then be narrowed by identifying genes involved in epigenetic regulation, and determining the pattern of expression following fertilization. Once a candidate list was assembled, involvement could be confirmed by analyzing their expression, localization and post-translational modifications in spontaneous and superovulated oocytes. Levels more similar to spontaneously ovulated oocytes and embryos would be expected in superovulated oocytes and embryos with preserved imprinted methylation, while aberrant levels would be expected those that had lost imprinted methylation.

Once the maternal-effect gene products disrupted by superovulation have been identified, the next step will be to determine non-invasive ways to determine which oocytes display improper expression, activity or localization of these products, and exclude the oocytes from use in the human clinic. One possible technique is through sampling of the polar body, provided that this does not have any negative developmental consequences for the oocyte. Alternatively, indirect methods of evaluating the status of the maternal effects genes may prove useful, such as measurements of by-products of the pathway involving the maternal-effects gene in the medium used to culture oocytes prior to fertilization.

#### **6.4.2 Embryo Culture**

While we hypothesize that maternal-effects gene products are affected by ARTs, further investigation of how embryo culture disrupts genomic imprinting should also focus on how overall epigenetic mechanisms like DNA methylation and histone modifications, which are the marks of genomic imprinting, may be disrupted by the culture environment. For example, S-adenosyl methionine (SAM) is widely known as the universal methyl donor, responsible for donating methyl groups for use in DNA methylation, histone methylation, and a number of other important cellular processes (Loenen, 2006). A complex pathway results in breakdown and regeneration of SAM, involving important molecules such as methionine, glutathione, homocysteine and folate (Chiang et al., 1996). Altered concentrations of these components and/or altered

expression of enzymes responsible for their synthesis and degradation may underlie the epigenetic defects during embryo culture (Steele et al., 2005). Investigation of these pathways should also be undertaken in cultured and *in vivo*-derived embryos.

In addition, continued identification of epigenetic mechanisms, both general and specific to each imprinted loci will provide invaluable information. With respect to specific pathways, studies such as those being conducted in our lab by Lauren Magri focus on determining the different epigenetic mechanisms at work in embryonic versus extraembryonic tissues using siRNA based screening. Differential effects of ARTs on TE and ICM cells has been observed as evidenced by loss of methylation in extraembryonic, but not embryonic tissues at E9.5 (Mann et al., 2004). An understanding of the different regulatory molecules controlling imprint maintenance in these various cell lineages will provide additional insight into the identity of the maternal-effects gene(s) disrupted by ARTs and their downstream effectors. Additional investigations into the specific regulatory molecules at each imprinted domain are also needed. A number of imprinted loci are regulated in part by DNA binding proteins such as CTCF or YY1 (Kim et al., 2007; Kim and Kim, 2008; Li et al., 2008; Kim et al., 2009; Nativio et al., 2009). Identification of genes and proteins such as these, necessary for imprint maintenance across multiple imprinted domains provide additional candidates for the maternal-effects gene(s). Knowledge of these specific mechanisms will facilitate the development of targeted therapies aimed at correcting those pathways disrupted by ARTs.

With respect to rates of embryo development and metabolism, the quiet embryo hypothesis states that embryos with the greatest developmental potential exhibit a lower

level of metabolic activity (Leese, 2002). A more thorough investigation of the metabolic differences between embryos that maintain genomic imprinting and those that do not should be undertaken. Studies evaluating the quiet embryo hypothesis employed a technique for profiling metabolic byproducts such as amino acids, pyruvate, and glucose, and correlated this with embryo viability. Similar studies correlating profiles of the above metabolic products with genomic imprinting will help to further clarify the relationship reported in these studies.

### **6.4.3 Application to the Human Clinic**

Strict guidelines for clinical trials, elucidating side effects, toxicity levels and safety in specific patient populations have been put in place for the development of medications and medical techniques used to treat human disease, however a rigorous examination of techniques used in the treatment of infertility is lacking. As different human clinics employ a wide variety of treatment programs including the number and dosage of FSH injections, gonadotropin receptor hormone agonists or antagonists, and the conditions used for oocyte and embryo culture and *in vitro* fertilization, standardized comparisons between centers and in turn large-scale trials remain difficult. Significant advancements in the field leading to increase safety and efficacy of ARTs will need to come from studies of human embryos. While prospective studies are likely not morally defensible, or practically possible, more detailed record-keeping of protocols employed

during fertility treatments will facilitate retrospective studies which have already, and will continue to provide invaluable information.

Advanced maternal age and intrinsic subfertility of the couples must be taken into consideration when evaluating fertility treatment outcomes, including detailed analysis of maternal and paternal epigenomes to clarify the role of subfertility in adverse events following ARTs. Male infertility has begun to emerge as an important factor with respect to epigenetic abnormalities following ART. Loss of imprinting at certain key loci was observed more frequently in men with oligozoospermia than in those with normal semen (Marques et al., 2004), and for some embryos, displaying aberrant genomic imprinting following embryo culture, aberrant methylation was present in sperm prior to manipulation in culture (Kobayashi et al., 2009). Moreover, detailed follow up of the health of children born through ARTs is necessary moving forward. This will become especially crucial in the upcoming decades, as the first wave of ART-born children become older and into the age where conditions such as heart disease, diabetes and cancer begin to emerge.

Since loss of genomic imprinting following embryo culture is stochastic, but not random, and distinct groups of embryos are more likely than others to show severe imprinting defects, further investigations should focus on determining additional non-invasive characteristics that correlate with the epigenetic health of the preimplantation embryo. Correlation of other characteristics routinely evaluated in the embryo such as degree of fragmentation and blastomere size (Graham et al., 2000; Scott et al., 2000; Nagy et al., 2003; Borini et al., 2005) with genomic imprinting in cleavage stage embryos

and blastocysts may reveal additional ways to identify embryos with preserved genomic imprints.

Lastly, in the human clinic, the measure of a successful ART cycle is a clinical pregnancy, and correlation of imprinting status with implantation and pregnancy rates has not been done. Studies such as these are necessary to solidify the importance of the epigenetic status of the embryo with respect to clinical practice.

## **6.5 Conclusions**

Assisted reproductive technologies are important medical treatments that have enabled previously infertile couples to achieve successful pregnancies, and produce biological children. However, while these techniques are, on the whole, very safe procedures, it is important to realize that the manipulation of gametes and embryos is not without risks and potential consequences. Some of the consequences identified to date include an increased incidence of imprinting disorders, along with low birth weight and prematurity, and the long term effects on adult health have yet to be fully determined. The studies presented in this thesis further elucidate the effects of two of the most common ARTs, superovulation and embryo culture, on genomic imprinting. We have determined that superovulation alone can have a significant impact on genomic imprinting at multiple loci, and that this effect worsens with increased dose of hormones. We have also demonstrated that embryo culture, in media used today in the human clinic, results in disruption of genomic imprinting at multiple loci. We also show that the effects



of superovulation and genomic imprinting are additive; a greater number of embryos and imprinted loci are affected following multiple ARTs than with the use of a single intervention, suggesting that both techniques disrupt the same overall mechanisms. Lastly, we show that embryos displaying moderate rates of development are most similar to *in vivo*-derived embryos, a finding that supports the quiet embryo hypothesis (Leese, 2002), and that will hopefully prompt further exploration into correlation of non-invasive parameters with the epigenetic health of embryos in the human clinic. It will be up to those pursuing further research in this field to elucidate the mechanisms by which environmental insult affects the epigenetic health of the embryo, to determine accurate, repeatable and non-invasive techniques to detect these compromised embryos, and to continue to improve our current techniques to minimize the amount of adaptation that embryos will require to survive and grow outside the female reproductive tract. The ultimate goal of these studies is a decreased incidence of disease and improved long-term health of children born following ARTs.

## 6.6 References

- Aagaard, L., Laible, G., Selenko, P., Schmid, M., Dorn, R., Schotta, G., Kuhfittig, S., Wolf, A., Lebersorger, A., Singh, P. B. et al. (1999) 'Functional mammalian homologues of the *Drosophila* PEV-modifier Su(var)3-9 encode centromere-associated proteins which complex with the heterochromatin component M31', *EMBO J* 18(7): 1923-38.
- Akam, M. (1987) 'The molecular basis for metameric pattern in the *Drosophila* embryo', *Development* 101(1): 1-22.
- Alikani, M., Calderon, G., Tomkin, G., Garrisi, J., Kokot, M. and Cohen, J. (2000) 'Cleavage anomalies in early human embryos and survival after prolonged culture in-vitro', *Hum Reprod* 15(12): 2634-43.
- Anckaert, E., Adriaenssens, T., Romero, S., Dremier, S. and Smits, J. (2009) 'Unaltered imprinting establishment of key imprinted genes in mouse oocytes after in vitro follicle culture under variable follicle-stimulating hormone exposure', *Int J Dev Biol* 53(4): 541-8.
- Ayyanathan, K., Lechner, M. S., Bell, P., Maul, G. G., Schultz, D. C., Yamada, Y., Tanaka, K., Torigoe, K. and Rauscher, F. J., 3rd (2003) 'Regulated recruitment of HP1 to a euchromatic gene induces mitotically heritable, epigenetic gene silencing: a mammalian cell culture model of gene variegation', *Genes Dev* 17(15): 1855-69.
- Bellier, S., Chastant, S., Adenot, P., Vincent, M., Renard, J. P. and Bensaude, O. (1997) 'Nuclear translocation and carboxyl-terminal domain phosphorylation of RNA polymerase II delineate the two phases of zygotic gene activation in mammalian embryos', *EMBO J* 16(20): 6250-62.
- Biezinova, J., Svobodova, M., Oborna, I., Fingerova, H., Dosta, J. and Krskova, M. (2006) '[Embryo quality evaluation according to the speed of the first cleavage after conventional IVF]', *Ceska Gynekol* 71(2): 105-10.
- Borghol, N., Lornage, J., Blachere, T., Sophie Garret, A. and Lefevre, A. (2006) 'Epigenetic status of the H19 locus in human oocytes following in vitro maturation', *Genomics* 87(3): 417-26.
- Borini, A., Lagalla, C., Cattoli, M., Sereni, E., Sciajno, R., Flamigni, C. and Coticchio, G. (2005) 'Predictive factors for embryo implantation potential', *Reprod Biomed Online* 10(5): 653-68.
- Carlson, L. L., Page, A. W. and Bestor, T. H. (1992) 'Properties and localization of DNA methyltransferase in preimplantation mouse embryos: implications for genomic imprinting', *Genes Dev* 6(12B): 2536-41.
- Caspary, T., Cleary, M. A., Baker, C. C., Guan, X. J. and Tilghman, S. M. (1998) 'Multiple mechanisms regulate imprinting of the mouse distal chromosome 7 gene cluster', *Mol Cell Biol* 18(6): 3466-74.
- Chiang, P. K., Gordon, R. K., Tal, J., Zeng, G. C., Doctor, B. P., Pardhasaradhi, K. and McCann, P. P. (1996) 'S-Adenosylmethionine and methylation', *FASEB J* 10(4): 471-80.

- Christians, E., Davis, A. A., Thomas, S. D. and Benjamin, I. J. (2000) 'Maternal effect of Hsf1 on reproductive success', *Nature* 407(6805): 693-4.
- Claman, P., Armant, D. R., Seibel, M. M., Wang, T. A., Oskowitz, S. P. and Taymor, M. L. (1987) 'The impact of embryo quality and quantity on implantation and the establishment of viable pregnancies', *J In Vitro Fert Embryo Transf* 4(4): 218-22.
- Conover, J. C., Temeles, G. L., Zimmermann, J. W., Burke, B. and Schultz, R. M. (1991) 'Stage-specific expression of a family of proteins that are major products of zygotic gene activation in the mouse embryo', *Dev Biol* 144(2): 392-404.
- Cummins, J. M., Breen, T. M., Harrison, K. L., Shaw, J. M., Wilson, L. M. and Hennessey, J. F. (1986) 'A formula for scoring human embryo growth rates in in vitro fertilization: its value in predicting pregnancy and in comparison with visual estimates of embryo quality', *J In Vitro Fert Embryo Transf* 3(5): 284-95.
- Ding, F. and Chaillet, J. R. (2002) 'In vivo stabilization of the Dnmt1 (cytosine-5)-methyltransferase protein', *Proc Natl Acad Sci U S A* 99(23): 14861-6.
- Doherty, A. S., Mann, M. R., Tremblay, K. D., Bartolomei, M. S. and Schultz, R. M. (2000) 'Differential effects of culture on imprinted H19 expression in the preimplantation mouse embryo', *Biol Reprod* 62(6): 1526-35.
- Dong, J., Albertini, D. F., Nishimori, K., Kumar, T. R., Lu, N. and Matzuk, M. M. (1996) 'Growth differentiation factor-9 is required during early ovarian folliculogenesis', *Nature* 383(6600): 531-5.
- Droin, A. (1992) 'The developmental mutants of *Xenopus*', *Int J Dev Biol* 36(4): 455-64.
- Fauque, P., Jouannet, P., Lesaffre, C., Ripoche, M. A., Dandolo, L., Vaiman, D. and Jammes, H. (2007) 'Assisted Reproductive Technology affects developmental kinetics, H19 Imprinting Control Region methylation and H19 gene expression in individual mouse embryos', *BMC Dev Biol* 7: 116.
- Flach, G., Johnson, M. H., Braude, P. R., Taylor, R. A. and Bolton, V. N. (1982) 'The transition from maternal to embryonic control in the 2-cell mouse embryo', *EMBO J* 1(6): 681-6.
- Graham, J., Han, T., Porter, R., Levy, M., Stillman, R. and Tucker, M. J. (2000) 'Day 3 morphology is a poor predictor of blastocyst quality in extended culture', *Fertil Steril* 74(3): 495-7.
- Hamatani, T., Carter, M. G., Sharov, A. A. and Ko, M. S. (2004) 'Dynamics of global gene expression changes during mouse preimplantation development', *Dev Cell* 6(1): 117-31.
- Katari, S., Turan, N., Bibikova, M., Erinle, O., Chalian, R., Foster, M., Gaughan, J. P., Coutifaris, C. and Sapienza, C. (2009) 'DNA methylation and gene expression differences in children conceived in vitro or in vivo', *Hum Mol Genet* 18(20): 3769-78.
- Khosla, S., Dean, W., Brown, D., Reik, W. and Feil, R. (2001) 'Culture of preimplantation mouse embryos affects fetal development and the expression of imprinted genes', *Biol Reprod* 64(3): 918-26.
- Kim, J. and Kim, J. D. (2008) 'In vivo YY1 knockdown effects on genomic imprinting', *Hum Mol Genet* 17(3): 391-401.

- Kim, J. D., Hinz, A. K., Choo, J. H., Stubbs, L. and Kim, J. (2007) 'YY1 as a controlling factor for the Peg3 and Gnas imprinted domains', *Genomics* 89(2): 262-9.
- Kim, J. D., Kang, K. and Kim, J. (2009) 'YY1's role in DNA methylation of Peg3 and Xist', *Nucleic Acids Res* 37(17): 5656-64.
- Kobayashi, H., Hiura, H., John, R. M., Sato, A., Otsu, E., Kobayashi, N., Suzuki, R., Suzuki, F., Hayashi, C., Utsunomiya, T. et al. (2009) 'DNA methylation errors at imprinted loci after assisted conception originate in the parental sperm', *Eur J Hum Genet* 17(12): 1582-91.
- Koerner, M. V., Pauler, F. M., Huang, R. and Barlow, D. P. (2009) 'The function of non-coding RNAs in genomic imprinting', *Development* 136(11): 1771-83.
- Leese, H. J. (2002) 'Quiet please, do not disturb: a hypothesis of embryo metabolism and viability', *Bioessays* 24(9): 845-9.
- Lehnertz, B., Ueda, Y., Derijck, A. A., Braunschweig, U., Perez-Burgos, L., Kubicek, S., Chen, T., Li, E., Jenuwein, T. and Peters, A. H. (2003) 'Suv39h-mediated histone H3 lysine 9 methylation directs DNA methylation to major satellite repeats at pericentric heterochromatin', *Curr Biol* 13(14): 1192-200.
- Lewis, A., Mitsuya, K., Umlauf, D., Smith, P., Dean, W., Walter, J., Higgins, M., Feil, R. and Reik, W. (2004) 'Imprinting on distal chromosome 7 in the placenta involves repressive histone methylation independent of DNA methylation', *Nat Genet* 36(12): 1291-5.
- Li, E., Beard, C. and Jaenisch, R. (1993) 'Role for DNA methylation in genomic imprinting', *Nature* 366(6453): 362-5.
- Li, T., Hu, J. F., Qiu, X., Ling, J., Chen, H., Wang, S., Hou, A., Vu, T. H. and Hoffman, A. R. (2008) 'CTCF regulates allelic expression of Igf2 by orchestrating a promoter-polycomb repressive complex 2 intrachromosomal loop', *Mol Cell Biol* 28(20): 6473-82.
- Li, T., Vu, T. H., Ulaner, G. A., Littman, E., Ling, J. Q., Chen, H. L., Hu, J. F., Behr, B., Giudice, L. and Hoffman, A. R. (2005) 'IVF results in de novo DNA methylation and histone methylation at an Igf2-H19 imprinting epigenetic switch', *Mol Hum Reprod* 11(9): 631-40.
- Loenen, W. A. (2006) 'S-adenosylmethionine: jack of all trades and master of everything?', *Biochem Soc Trans* 34(Pt 2): 330-3.
- Ludwig, M., Katalinic, A., Gross, S., Sutcliffe, A., Varon, R. and Horsthemke, B. (2005) 'Increased prevalence of imprinting defects in patients with Angelman syndrome born to subfertile couples', *J Med Genet* 42(4): 289-91.
- Mann, M. R., Lee, S. S., Doherty, A. S., Verona, R. I., Nolen, L. D., Schultz, R. M. and Bartolomei, M. S. (2004) 'Selective loss of imprinting in the placenta following preimplantation development in culture', *Development* 131(15): 3727-35.
- Markert, C. L. (1982) 'Parthenogenesis, homozygosity, and cloning in mammals', *J Hered* 73(6): 390-7.
- Marques, C. J., Carvalho, F., Sousa, M. and Barros, A. (2004) 'Genomic imprinting in disruptive spermatogenesis', *Lancet* 363(9422): 1700-2.

- McGrath, J. and Solter, D. (1984) 'Completion of mouse embryogenesis requires both the maternal and paternal genomes', *Cell* 37(1): 179-83.
- Morisato, D. and Anderson, K. V. (1995) 'Signaling pathways that establish the dorsal-ventral pattern of the Drosophila embryo', *Annu Rev Genet* 29: 371-99.
- Nagy, Z. P., Dozortsev, D., Diamond, M., Rienzi, L., Ubaldi, F., Abdelmassih, R. and Greco, E. (2003) 'Pronuclear morphology evaluation with subsequent evaluation of embryo morphology significantly increases implantation rates', *Fertil Steril* 80(1): 67-74.
- Nakamura, T., Arai, Y., Umehara, H., Masuhara, M., Kimura, T., Taniguchi, H., Sekimoto, T., Ikawa, M., Yoneda, Y., Okabe, M. et al. (2007) 'PGC7/Stella protects against DNA demethylation in early embryogenesis', *Nat Cell Biol* 9(1): 64-71.
- Nakao, M., Matsui, S., Yamamoto, S., Okumura, K., Shirakawa, M. and Fujita, N. (2001) 'Regulation of transcription and chromatin by methyl-CpG binding protein MBD1', *Brain Dev* 23 Suppl 1: S174-6.
- Nativio, R., Wendt, K. S., Ito, Y., Huddleston, J. E., Uribe-Lewis, S., Woodfine, K., Krueger, C., Reik, W., Peters, J. M. and Murrell, A. (2009) 'Cohesin is required for higher-order chromatin conformation at the imprinted IGF2-H19 locus', *PLoS Genet* 5(11): e1000739.
- Paoloni-Giacobino, A. and Chaillet, J. R. (2004) 'Genomic imprinting and assisted reproduction', *Reprod Health* 1(1): 6.
- Pardo, P. S., Leung, J. K., Lucchesi, J. C. and Pereira-Smith, O. M. (2002) 'MRG15, a novel chromodomain protein, is present in two distinct multiprotein complexes involved in transcriptional activation', *J Biol Chem* 277(52): 50860-6.
- Payer, B., Saitou, M., Barton, S. C., Thresher, R., Dixon, J. P., Zahn, D., Colledge, W. H., Carlton, M. B., Nakano, T. and Surani, M. A. (2003) 'Stella is a maternal effect gene required for normal early development in mice', *Curr Biol* 13(23): 2110-7.
- Quinn, P. and Horstman, F. C. (1998) 'Is the mouse a good model for the human with respect to the development of the preimplantation embryo in vitro?', *Hum Reprod* 13 Suppl 4: 173-83.
- Sasaki, H., Ferguson-Smith, A. C., Shum, A. S., Barton, S. C. and Surani, M. A. (1995) 'Temporal and spatial regulation of H19 imprinting in normal and uniparental mouse embryos', *Development* 121(12): 4195-202.
- Sato, A., Otsu, E., Negishi, H., Utsunomiya, T. and Arima, T. (2007) 'Aberrant DNA methylation of imprinted loci in superovulated oocytes', *Hum Reprod* 22(1): 26-35.
- Schultz, R. M. (1993) 'Regulation of zygotic gene activation in the mouse', *Bioessays* 15(8): 531-8.
- Scott, L., Alvero, R., Leondires, M. and Miller, B. (2000) 'The morphology of human pronuclear embryos is positively related to blastocyst development and implantation', *Hum Reprod* 15(11): 2394-403.
- Shoukir, Y., Campana, A., Farley, T. and Sakkas, D. (1997) 'Early cleavage of in-vitro fertilized human embryos to the 2-cell stage: a novel indicator of embryo quality and viability', *Hum Reprod* 12(7): 1531-6.

- Steele, W., Allegrucci, C., Singh, R., Lucas, E., Priddle, H., Denning, C., Sinclair, K. and Young, L. (2005) 'Human embryonic stem cell methyl cycle enzyme expression: modelling epigenetic programming in assisted reproduction?', *Reprod Biomed Online* 10(6): 755-66.
- Summers, M. C. and Biggers, J. D. (2003) 'Chemically defined media and the culture of mammalian preimplantation embryos: historical perspective and current issues', *Hum Reprod Update* 9(6): 557-82.
- Surani, M. A., Barton, S. C. and Norris, M. L. (1984) 'Development of reconstituted mouse eggs suggests imprinting of the genome during gametogenesis', *Nature* 308(5959): 548-50.
- Tashiro, F., Kanai-Azuma, M., Miyazaki, S., Kato, M., Tanaka, T., Toyoda, S., Yamato, E., Kawakami, H., Miyazaki, T. and Miyazaki, J. (2010) 'Maternal-effect gene *Ces5/Ooep/Moep19/Floped* is essential for oocyte cytoplasmic lattice formation and embryonic development at the maternal-zygotic stage transition', *Genes Cells* 15(8): 813-28.
- Tong, Z. B., Bondy, C. A., Zhou, J. and Nelson, L. M. (2002) 'A human homologue of mouse *Mater*, a maternal effect gene essential for early embryonic development', *Hum Reprod* 17(4): 903-11.
- Tong, Z. B., Gold, L., Pfeifer, K. E., Dorward, H., Lee, E., Bondy, C. A., Dean, J. and Nelson, L. M. (2000) '*Mater*, a maternal effect gene required for early embryonic development in mice', *Nat Genet* 26(3): 267-8.
- Turek-Plewa, J. and Jagodzinski, P. P. (2005) 'The role of mammalian DNA methyltransferases in the regulation of gene expression', *Cell Mol Biol Lett* 10(4): 631-47.
- Van der Auwera, I. and D'Hooghe, T. (2001) 'Superovulation of female mice delays embryonic and fetal development', *Hum Reprod* 16(6): 1237-43.
- Van Montfoort, A. P., Dumoulin, J. C., Kester, A. D. and Evers, J. L. (2004) 'Early cleavage is a valuable addition to existing embryo selection parameters: a study using single embryo transfers', *Hum Reprod* 19(9): 2103-8.
- Wan, L. B. and Bartolomei, M. S. (2008) 'Regulation of imprinting in clusters: noncoding RNAs versus insulators', *Adv Genet* 61: 207-23.
- Weaver, J. R., Sarkisian, G., Krapp, C., Mager, J., Mann, M. R. and Bartolomei, M. S. (2010) 'Domain-specific response of imprinted genes to reduced DNMT1', *Mol Cell Biol* 30(16): 3916-28.
- Weitzman, V. N., Schnee-Riesz, J., Benadiva, C., Nulsen, J., Siano, L. and Maier, D. (2010) 'Predictive value of embryo grading for embryos with known outcomes', *Fertil Steril* 93(2): 658-62.
- Windt, M. L., Kruger, T. F., Coetzee, K. and Lombard, C. J. (2004) 'Comparative analysis of pregnancy rates after the transfer of early dividing embryos versus slower dividing embryos', *Hum Reprod* 19(5): 1155-62.
- Wu, X., Viveiros, M. M., Eppig, J. J., Bai, Y., Fitzpatrick, S. L. and Matzuk, M. M. (2003) 'Zygote arrest 1 (*Zar1*) is a novel maternal-effect gene critical for the oocyte-to-embryo transition', *Nat Genet* 33(2): 187-91.

- Zheng, P. and Dean, J. (2009) 'Role of Filia, a maternal effect gene, in maintaining euploidy during cleavage-stage mouse embryogenesis', *Proc Natl Acad Sci U S A* 106(18): 7473-8.
- Zheng, P., Schramm, R. D. and Latham, K. E. (2005) 'Developmental regulation and in vitro culture effects on expression of DNA repair and cell cycle checkpoint control genes in rhesus monkey oocytes and embryos', *Biol Reprod* 72(6): 1359-69.
- Zheng, P., Vassena, R. and Latham, K. E. (2007) 'Effects of in vitro oocyte maturation and embryo culture on the expression of glucose transporters, glucose metabolism and insulin signaling genes in rhesus monkey oocytes and preimplantation embryos', *Mol Hum Reprod* 13(6): 361-71.

## **Appendices**

### **Appendix 1: Single Embryo Methodology**

#### **Limitations of the blastocyst**

The analysis of the imprinted methylation status of individual blastocysts has proved challenging due to the very small amounts of DNA present. Mouse blastocysts on average contain 64 cells but we have found that this can range from 20-120 cells, Each cell contains approximately 6 pg of genomic DNA. Each blastocyst will therefore contain 120-720 pg of genomic DNA. This amount of DNA is a barrier to DNA isolation and PCR amplification. Furthermore for methylation analyses, bisulfite treatment of genomic DNA is a relatively harsh technique, during which DNA degradation will occur. To get an accurate picture of the methylation status of an imprinting center, information from approximately 10 different alleles of both the maternal and paternal alleles is necessary. Thus, methodology for the analysis of DNA methylation in blastocyst-stage embryos must overcome all of these challenges. Simply stated, it must protect the DNA from degradation, efficiently isolate DNA, and amplify the small amount of DNA remaining to a detectable level while still maintaining enough variation to recover the necessary number of maternal and paternal DNA strands. On top of this, our goal is to recover both DNA and RNA from individual blastocysts to determine both imprinted methylation and expression status in the same embryo.



## **Bisulfite Conversion**

The first step in the development of the technique was to optimize the bisulfite conversion i.e. to ensure complete conversion of unmethylated cytosines (>85%) while maintaining the integrity and quantity of DNA. We first employed a pre-released bisulfite conversion kit, the EZ-DNA Methylation Kit (Zymo Research), asserting to be the most sensitive bisulfite kit. Multiple conversion times and temperatures were tested, and optimized parameters were found to be 50°C and 3.5 hours, respectively. While amplification from all four genes using a nested PCR strategy was possible with this kit, it was inconsistent. We concluded that this kit resulted in insufficient recovery of DNA to consistently recover PCR products for multiple genes. Our next attempt used a modified technique in which DNA was treated with sodium bisulfite while embedded in an agarose bead in an effort to protect the DNA from degradation. DNA was then isolated from the agarose bead using the Qiagen gel extraction buffer (Buffer QG, Qiagen) followed by DNA isolation using the columns provided in the EZ-DNA methylation kit. Nested PCR was performed after bisulfite treatment using this method and it was determined that amplification of PCR product from all four genes was repeatable, although too little DNA was recovered to allow for amplification of multiple alleles of each imprinting center. Furthermore, an insufficient number of clones were obtained for each imprinting center

While working on a separate project that used the Methyl Detector Kit (Active Motif) for large cell numbers, I performed multiple elutions as less than the expected

amount of DNA was recovered. I determined that large amounts of DNA remained in the column after the first, second and even the third DNA elution. This prompted us to consider that DNA recovery from the EZ-DNA columns was suboptimal. A new protocol was developed in which following bisulfite conversion in the agarose bead, the bead itself was split and added to individual PCR reactions for each gene. We determined via PCR followed by allele- and methylation-specific restriction digest, that this method allowed for sufficient DNA recovery for both parental alleles of all imprinting centers of interest to be PCR amplified and a sufficient number of clones to be obtained for sequence analysis.

### **PCR Optimization**

Typically following bisulfite mutagenesis, a nested PCR is performed to enrich the region of interest and allow for amplification of many DNA strands of each imprinting center. In the first round, primers are specific for a larger area encompassing a region within the imprinting center of interest. In the second round, primers are designed within the enriched sequence to generate a smaller final PCR product. As a diagnostic, following the nested PCR, samples are digested using restriction enzymes that cut the methylated allele but not the unmethylated allele to ensure enough variability in the amplified sequences. It was found that using the agarose bead method followed by column DNA extraction, PCR bias was observed for all genes tested; either the majority of alleles obtained were methylated or unmethylated. Subsequent PCR optimization was performed. Parameters that were changed include: multiplex or individual PCR,

annealing time, annealing temperatures, extension time, extension temperatures, number of cycles, volume and type of elution buffer used in EZ-DNA column, volume of starting material added to PCR reactions, primer concentrations, MgCl<sub>2</sub> concentrations, presence or absence of DMSO, and total PCR reaction volume. Multiple gradient PCRs were performed for individual genes as well as various combinations of multiplexed genes. The optimal state of each of the above parameters was obtained. Optimization of the nested PCR in combination with the agarose bead bisulfite conversion method produced a sufficient numbers of clones for sequencing.

### **Crossover Events**

Crossover events are thought to occur during PCR amplification when there is a high concentration of very similar sequences, and the annealing temperature of the PCR reaction is such that these similar sequence can bind to one another. After receiving sequence data for the agarose bead protocol alone, multiple crossover events were observed in *Snrpn*, *H19* and *Peg3*. To alleviate this problem, annealing temperatures were increased for first round PCR to increase stringency and prevent binding of similar sequences. Increasing the annealing temperature of the first round PCR of *Snrpn*, *H19* and *Peg3* resulted in decreased crossover events and successful recovery of sufficient numbers of sequences.

### **Cloning of PCR Products**

Once DNA is isolated and PCR amplified, we initially employed a clean-up step prior to cloning. Following second round PCR, gel extraction of the desired bands was performed using the Qiagen Gel Extraction Kit (Qiagen), then the extracted DNA was TA-cloned. Our subsequent analysis determined that gel extraction decreased the variability of DNA strands recovered and introduced a bias towards the unmethylated alleles. To resolve this issue, amplified DNA was cloned directly from the 2<sup>nd</sup> round PCR product.

One problem arising from the direct cloning of PCR products was a decrease in the number of correct inserts recovered. This is due to primer-dimer and non-specific amplicon insertion. To reduce the number of unnecessary miniplasmid preparations (minipreps), a strategy for screening colonies was developed. Individual colonies were picked, quickly dipped into the PCR reaction, and put into tubes containing LB/AMP to grow up overnight. M13 forward and reverse primers that flank the insertion site were used to amplify the cloned insert then agarose gel analysis was used to assess the size of the inserted DNA. Those colonies that did not contain the appropriate size insert were discarded while minipreps were performed for colonies with the appropriately sized insert. This strategy worked well for all genes except *Snrpn*, whose recovery of correct amplicon sizes decreased to <30% due to the lack of gel extraction of DNA. In lieu of column purification, PCR reactions were electrophoresed on an agarose gel, and thin bands containing the amplicon of interest were excised. Gel fragments were incubated overnight in TE to allow DNA to diffuse from the gel. The DNA solution was then used directly for ligation and subsequent transformation. Nearly all clones obtained through

this method contained the appropriate sized insert.

To develop a more high-throughput protocol, we bypassed the minipreps, and amplicons obtained from bacterial colonies using M13 primers were sent directly to be sequenced. No cross contamination, and good chromatogram results were observed. Thus this method is an equally accurate way to obtain sequence information from individual colonies. Minipreps are no longer performed before clones were sent for sequencing. Instead following nested PCR and gel electrophoresis, DNA isolated via gel diffusion was ligated and transformed, bacterial colonies were picked directly into a PCR reaction containing M13 primers, then the resulting amplicon was sent directly for sequencing.

### **Analysis of Methylation and Allele-Specific Expression**

After it was found that enough clones of both methylated and unmethylated alleles from all 4 genes could be obtained from individual blastocysts, we developed a protocol to analyze both expression and methylation from individual blastocysts. The protocol previously developed isolated RNA and produced a reusable cDNA-Dynabead library (DynaL Biotech). To combine the protocols for DNA isolation/bisulfite conversion and RNA isolation/cDNA-Dynabead library synthesis, I made the following modifications. Individual blastocysts were lysed in Dynabead lysis buffer using a decreased volume of lysis buffer, an increased time for lysis and annealing of RNA to Dynabeads, and modified the lysis procedure by combining vortexing and mixing followed by gentle centrifugation of samples. Lastly, since the Dynal lysis buffer does not completely and consistently break open the nuclear membrane, after lysis and annealing of RNA to

Dynabeads as described above, supernatant containing cell debris and nuclei were removed to a new tube. To liberate genomic DNA, Protease K and NP40 (final concentration of 0.1%) were added and the samples were incubated for 1 hour at 50°C. Bisulfite conversion and cDNA-Dynabead library synthesis were unchanged for the rest of the protocol. I have determined that there was no difference in data obtained for imprinted methylation and expression using this new protocol versus either protocol alone.

This protocol was employed for embryo analysis in Chapter 2-5. The final protocol with notes can be found below.

### **Full Protocol: Single Embryo Analysis of Methylation and Expression**

#### **(A) Pre-Wash Dynabeads**

1. Vortex Dynabeads on medium speed to re-suspend. Change gloves.
2. Label one 0.2 mL thin walled PCR tube per sample plus an additional tube for a negative control.
3. Transfer 10 µl of Dynabeads to each 0.2 mL thin walled PCR tube.
4. Place into Magnetic Particle Concentrator (MPC). Remove supernatant.
5. Add 100 µl Dynabead Lysis Buffer to each sample.
6. Vortex on low for 5-10 seconds, place on MPC, then remove buffer. Repeat.

#### **(B) Embryo Lysis**

1. Retrieve individually frozen embryos from storage at  $-80^{\circ}\text{C}$  (*see* Note 2).
2. Centrifuge briefly to ensure embryo is at bottom of tube (~5 seconds at 10,000-13,000 rpm).
3. Add 10  $\mu\text{l}$  of Dynabead lysis buffer to each sample.
4. Prior to adding embryo, place in MPC and remove lysis buffer from pre-washed Dynabeads from Step 6 above.
5. Transfer entire contents of lysed embryo sample from Step 3 to pre-washed Dynabeads.
6. Mix gently by flicking, then centrifuge briefly at 4000 rpm.
7. Incubate with slow agitation on vortex for 5-10 min at room temperature to allow for hybridization of mRNA to Dynabead.
8. Centrifuge briefly at 4000 rpm.
9. Place mRNA-Dynabead tube in MPC. Remove supernatant containing DNA to original embryo tubes, taking care not to remove any mRNA-Dynabeads.
10. Add 200  $\mu\text{L}$  of Dynabead Wash Buffer A to mRNA-Dynabeads. Place in MPC and set aside until 3.3 RNA isolation.
11. Centrifuge tubes containing DNA/supernatant for 5-10 seconds at 13,000 rpm to remove bubbles.
12. Add 1  $\mu\text{l}$  Protease K (Sigma, Oakville, Canada) and 1  $\mu\text{l}$  of 10% Igepal (*see* Note 3) to each DNA/supernatant tube.
13. Centrifuge briefly at 13,000 rpm to remove any bubbles.

14. Add 300  $\mu\text{L}$  of DNase-, RNase- and protease-free mineral oil (Sigma, Oakville, Canada) to each tube (*see* Note 4).
15. Lyse embryo by incubating for 1 hour in waterbath at 50°C.

#### (C) RNA Isolation

1. Retrieve mRNA-Dynabead tube containing 200  $\mu\text{L}$  of Wash Buffer A.
2. Vortex on low speed for approximately 5 seconds. Centrifuge briefly. Place in MPC, then remove Wash.
3. Repeat washing step with Wash Buffer A once, and Wash Buffer B three times.

#### (D) Reverse Transcription and Generation of a Solid-Phase cDNA Library (*see* Note 5)

1. Prepare reverse transcription by mixing 2  $\mu\text{L}$  5x First Strand Buffer, 1  $\mu\text{L}$  0.1M DTT, 0.5  $\mu\text{L}$  10 mM dNTP, 0.5  $\mu\text{L}$  40 units/ $\mu\text{L}$  RNaseOut (Invitrogen, Burlington, Canada), 0.25  $\mu\text{L}$  Superscript II (Invitrogen, Burlington, Canada), 5.75  $\mu\text{L}$  H<sub>2</sub>O, for a 10  $\mu\text{L}$  reaction.
2. Remove all of Wash Buffer B from mRNA-Dynabead tube.
3. Add 10  $\mu\text{L}$  of RT mix to each sample.
4. Mix gently by flicking.
5. Centrifuge briefly. Repeat mixing and spin.
6. Incubate for 1-2 hours at 42°C rotating in hybridization oven.

#### (E) Agarose Bead Embedding of DNA



1. Remove Protease K-treated DNA tubes from waterbath. Place in heating block at  $> 95^{\circ}\text{C}$ .
2. Add 24  $\mu\text{L}$  2% LMP agarose (pre-warmed at  $>95^{\circ}\text{C}$ ) under mineral oil.
3. Mix gently by pipetting. Ensure the bead is well mixed.
4. Incubate for 3 minutes  $> 95^{\circ}\text{C}$  to inactivate the Protease K.
5. Incubate for 10 minutes on ice to allow agarose bead to harden.

#### (F) Denaturation of DNA

1. Remove oil from chilled, hardened agarose bead.
2. Add 1 mL 0.1 M NaOH to each tube. Invert 5-6 times (*see* Note 6).
3. Incubate for 15 minutes at  $37^{\circ}\text{C}$  in a waterbath, inverting every 3-4 min.

#### (G) Bisulfite Treatment of DNA

1. Spin gently ( $< 4000$  rpm) (*see* Note 7).
2. Remove NaOH solution.
3. Add 500  $\mu\text{L}$  of Bisulfite Solution.
4. Add 300  $\mu\text{L}$  of mineral oil. Ensure that agarose bead is floating in solution (*see* Note 8).
5. Incubate at  $50^{\circ}\text{C}$  in a waterbath for 3.5 hours (*see* Note 1).

#### (H) Clean-up of cDNA-Dynabead Library

1. Remove cDNA-Dynabead samples from hybridization oven.

2. Centrifuge briefly then place in MPC.
3. Remove all RT mix.
4. Add 10  $\mu$ l of ITT Buffer, flick gently to mix, centrifuge briefly, place in MPC, remove ITT Buffer. Repeat.
5. Add 10  $\mu$ l of ITT Buffer, flick gently to mix, centrifuge briefly.
6. Incubate 1 minute at 95°C in block of pre-warmed PCR machine.
7. Working with one sample at a time, centrifuge briefly, place in MPC, remove ITT buffer.
8. Add 100  $\mu$ l of ITT Buffer, flick gently to mix, centrifuge briefly, place in MPC, remove ITT Buffer. Repeat.
9. Store cDNA-Dynabead Library at 4°C (*see* Note 9)

#### (I) Second strand synthesis

1. Remove cDNA-Dynabead library from storage at 4°C, add 100  $\mu$ l of ITT Buffer, flick gently to mix, centrifuge briefly, place in MPC, remove ITT Buffer. Repeat.
2. Prepare separate forward and reverse reactions according to protocols for your gene of interest.
3. Place cDNA-Dynabead library in MPC, remove ITT buffer (make sure all of liquid is removed).
4. Add forward reaction, flick gently to mix.
5. Place reaction in PCR machine, run PCR program for one cycle, according to your gene of interest.

6. Remove samples one at a time, spin down quickly in benchtop centrifuge, place in MPC and remove all of 2<sup>nd</sup> strand product to new tube.
7. Transfer an equivalent amount of forward-2<sup>nd</sup> strand mix to tubes containing pre-aliquoted reverse Mix.
8. Run PCR as per your gene of interest.
9. Rehydrate cDNA-Dynabead library by adding 100  $\mu$ l of ITT Buffer, flick gently to mix, centrifuge briefly, place in MPC, remove ITT Buffer. Repeat.
10. Store cDNA-Dynabead Library at 4°C (*see* Note 10).

#### (J) Desulfonation of Bisulfite Treated DNA

1. Remove DNA-agarose tubes from 50°C waterbath.
2. Incubate on ice for 3 minutes.
3. Remove Bisulfite solution and mineral oil.
4. Centrifuge briefly (<4000 rpm).
5. Add 1 mL of TE, invert 1-2 times, centrifuge briefly then remove TE.
6. Add 1 mL 0.3 M NaOH, flick gently to mix, invert 5-6 times.
7. Incubate at 37°C in a waterbath for 15 minutes, inverting every 3-4 minutes.
8. Centrifuge briefly (<4000 rpm).

#### (K) Washing of Desulfonated DNA

1. Remove NaOH.
2. Add 1 mL of TE.

3. Incubate for 5-10 minutes at room temperature with shaking.
4. Spin gently, remove TE, repeat wash once more with TE.
5. Repeat wash twice more with H<sub>2</sub>O.
6. Check pH of washes. The last H<sub>2</sub>O wash should have approximate pH 5. If solution is more basic, perform two additional washes with H<sub>2</sub>O.
7. Samples are now ready for amplification of gene(s) of interest with bisulfite-specific primers (*see* Note 11).

### Notes

1. BS is light sensitive. Cover Bisulfite solutions, Parts I and II, with foil until ready to use. Cover all samples in foil once Bisulfite mixture is added, and keep covered until after the 3.5 hour incubation.
2. Embryos should be stored in a minimal amount of culture medium (1-2  $\mu$ L).
3. The use of 10% Igepal is to ensure lysis of nuclear membrane as well as cell membrane.
4. Mineral oil is used to ensure that solutions do not evaporate and condense on the top of the tubes during the procedure.
5. Generation of a solid-phase library is important as it allows for re-use of Dynabeads and amplification of an essentially unlimited number of genes.
6. Invert samples gently. The agarose bead should be mixed but vigorous shaking can cause the agarose bead to break up into pieces.

7. Centrifugation of the agarose bead should not exceed 4000 rpm to prevent breakage of agarose bead.
8. The agarose bead should be floating prior to incubation with the Bisulfite solution to ensure that all sides of the agarose bead are exposed to the Bisulfite solution. If the bead does not float, use a pipette tip to release it from the bottom of the tube.
9. For best results, use cDNA-Dynabead library as soon as possible. Consistent amplification has been obtained for cDNA libraries stored up to 8 months.
10. Caution: Dynabeads can be easily lost during each washing step; ensure all Dynabeads are localized to the magnetic side of the tube before removing any supernatant. Also, following repeated heating (multiple second strand syntheses), Dynabeads may clump. If this occurs consider performing an additional washing step.
11. Set up PCR reactions. To increase PCR efficiency, add 1  $\mu$ l 240 ng/ml tRNA as a carrier to PCR reaction. At 70°C, add to the 30  $\mu$ l-agarose bead the required amount of water to make up 20  $\mu$ l per gene(s) of interest (up to 4 genes). Mix agarose and water by gently pipetting. Keeping the solution at 60-70°C, mix by gently pipetting, then split the PCR reaction in two by removing 12.5  $\mu$ l into a new 0.2 mL thin walled PCR tube. Add 12.5  $\mu$ l mineral oil overlay. This allows for two independent PCR reactions. PCR amplification from the agarose bead should be performed immediately. If this is not possible, the agarose bead can be stored at 4°C up to one week. However, efficient amplification will decrease dramatically with each day of incubation.

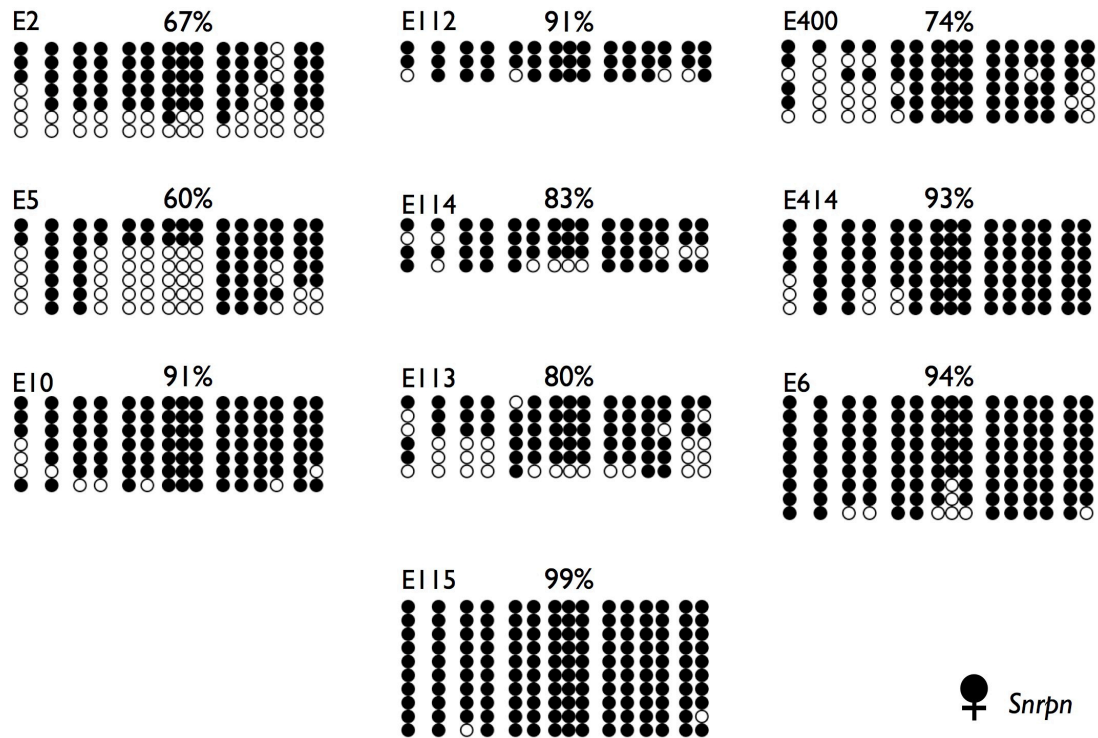
## **Appendix 2: Perl Program for Sequencing Analysis**

The following perl program was designed to facilitate the analysis of sequencing data obtained through the course of these experiments. The initial work on the program was done during the Bioinformatics graduate course taught by Dr. G. Gloor and was designed to read in and analyze each sequence individually. The program was then expanded to all 5 genes analyzed: *H19*, *Snrpn*, *Peg3*, *Kcnq1ot1*, and *Peg1/Mest*. To further increase the efficiency of the analysis I enlisted the help of a colleague, Mr. Robert Moreland, a classmate at the Schulich School of Medicine, who made some modifications to the program to allow for analysis of all sequences with only one line of input code required, rather than one line of input per sequence. The file entitled “Market-Velker\_Brenna\_A\_201106\_PhD\_appendix.pl” represents the perl programming currently used for sequence analysis.

### **Appendix 3: Supplementary Material - Chapter 2**

The following figures were presented as supplemental data to the experiments presented in Chapter 2, published as:

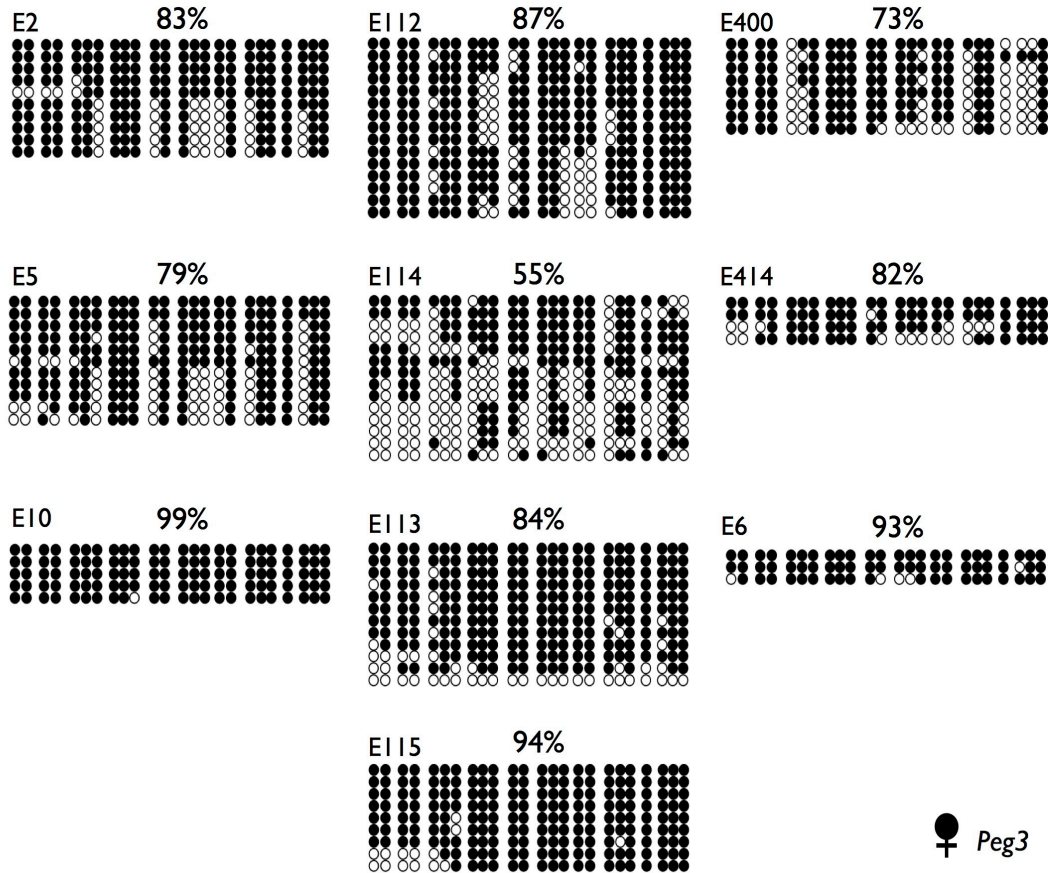
Market-Velker, B.A., Zhang, L., Magri, L.S., Bonvissuto, A.C. & Mann, M.R. Dual effects of superovulation: loss of maternal and paternal imprinted methylation in a dose-dependent manner. *Hum Mol Genet* 19, 36-51 (2010).



**Supplementary Figure 2.1. Methylation of the Maternal *Snrpn* ICR in B6(CAST7) X B6 F<sub>1</sub> Embryos Derived from Spontaneously Ovulated Females.**

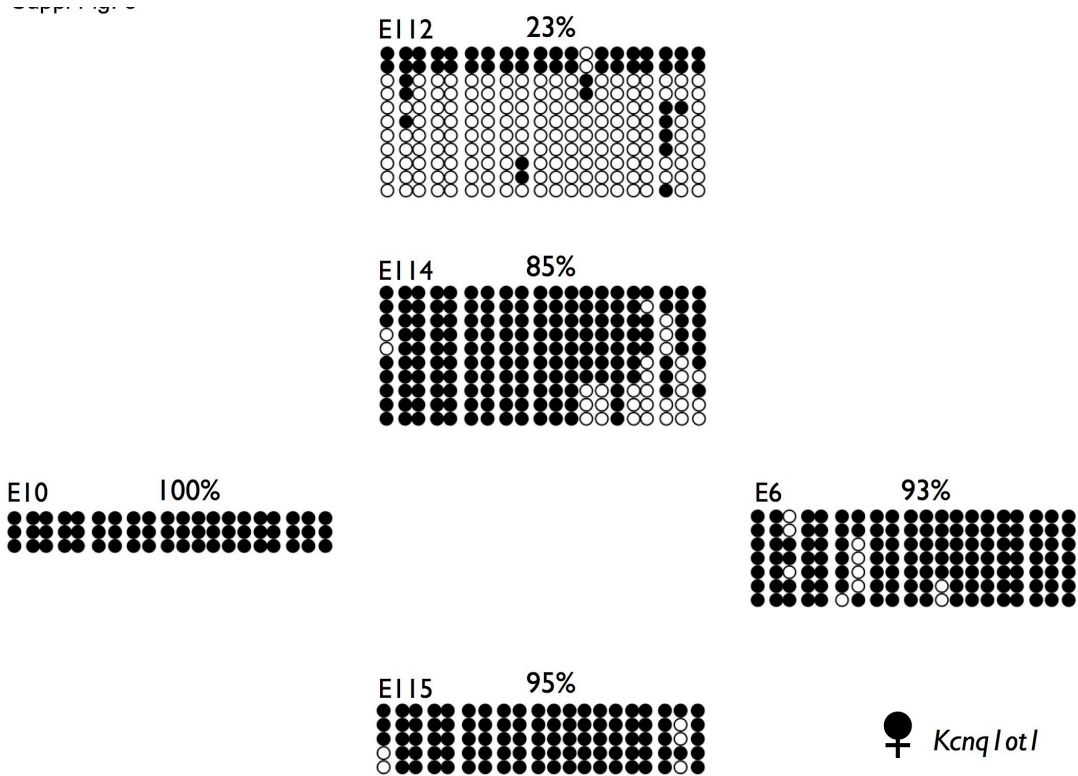
Methylation status of individual DNA strands in the *Snrpn* ICR (maternal, CAST strands shown) in blastocysts derived from spontaneously ovulated females as determined by bisulfite mutagenesis and sequencing analysis. Unmethylated CpGs are represented as empty circles while methylated CpGs are depicted as filled circles. Each line denotes an individual strand of DNA. Clones with identical methylation patterns and non-CpG conversion rates representing the same DNA strand were included once. Each group of DNA strands represents data from a single embryo, with the embryo designation indicated at the top left. Percent CpG methylation is indicated above each set of DNA strands, and was calculated as the number of methylated CpGs / total number of CpG dinucleotides. The region analyzed contains 15 CpGs; a base pair change in the maternal CAST allele eliminates CpG dinucleotide 1.





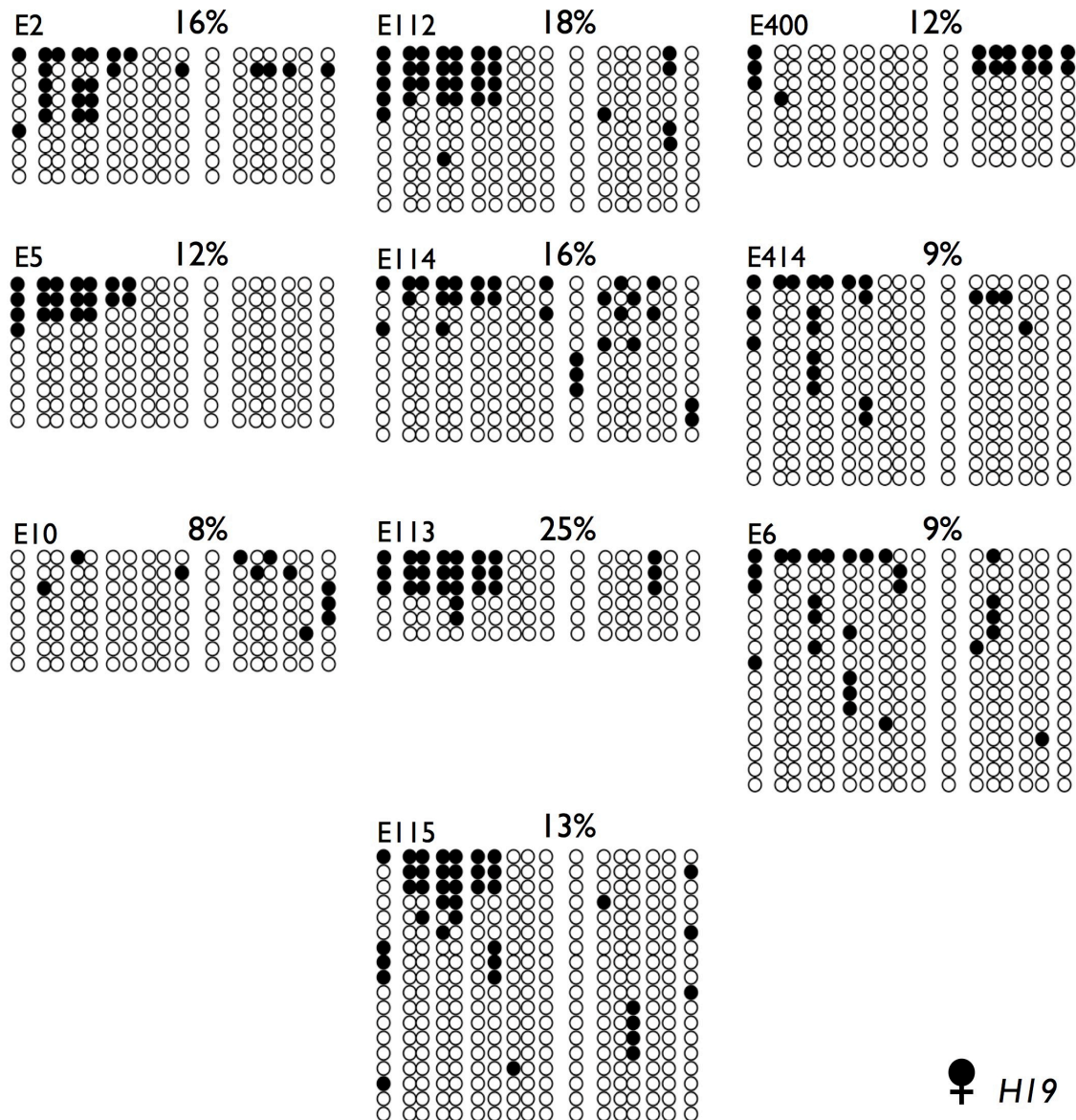
**Supplementary Figure 2.2. Methylation of the Maternal *Peg3* DMR in B6(CAST7) X B6 F<sub>1</sub> Embryos Derived from Spontaneously Ovulated Females.**

Methylation status of individual DNA strands in the *Peg3* DMR (maternal, CAST strands shown) in blastocysts derived from spontaneously ovulated females. The region analyzed contains 24 CpGs. Details are as described in Supplementary Figure 2.1.



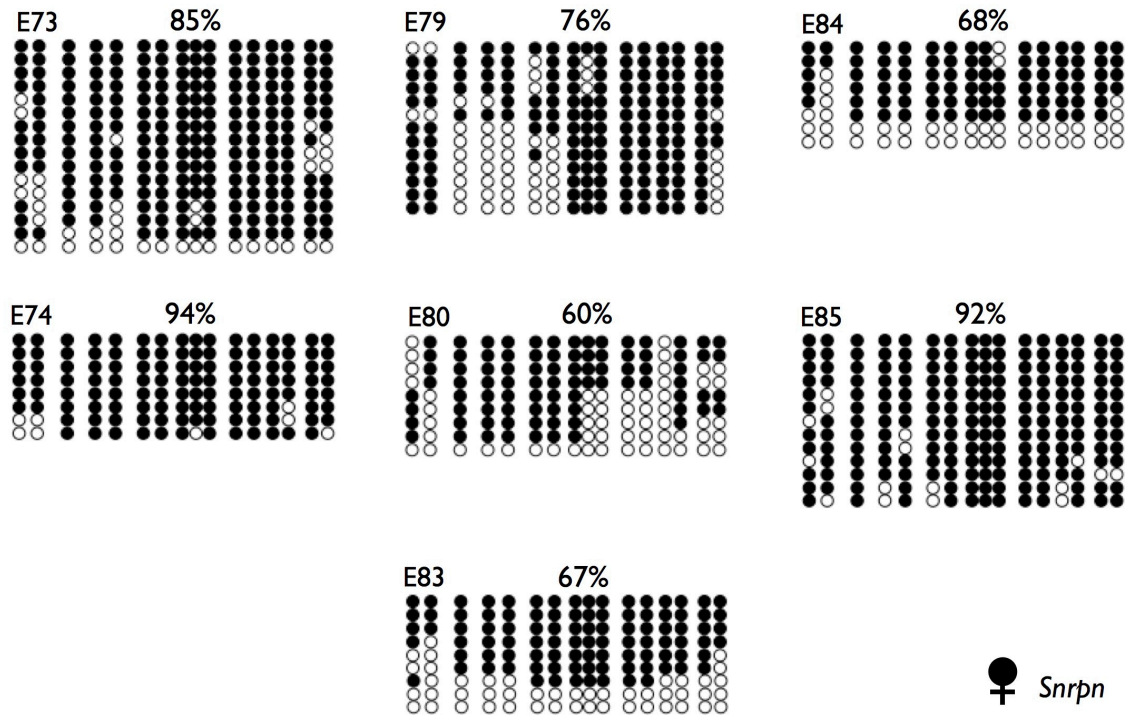
**Supplementary Figure 2.3. Methylation of the Maternal *Kcnq1ot1* ICR in B6(CAST7) X B6 F<sub>1</sub> Embryos Derived from Spontaneously Ovulated Females.**

Methylation status of individual DNA strands in the *Kcnq1ot1* ICR (maternal, CAST strands shown) in blastocysts derived from spontaneously ovulated females. Details are as described in Supplementary Figure 2.1.



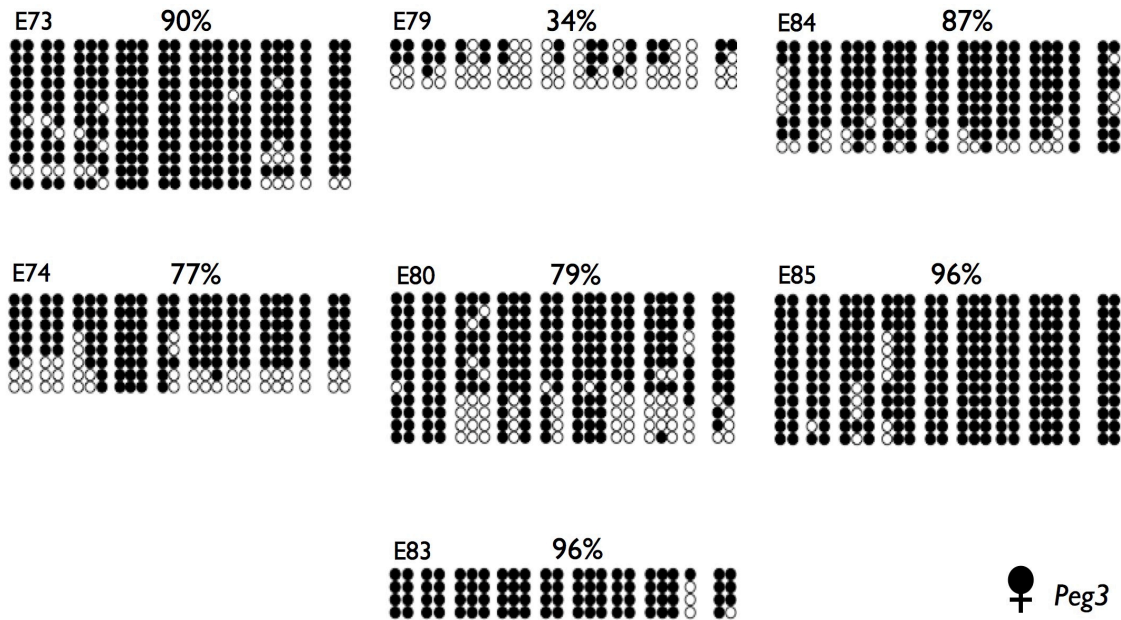
**Supplementary Figure 2.4. Methylation of the Maternal *H19* ICR in B6(CAST7) X B6 F<sub>1</sub> Embryos Derived from Spontaneously Ovulated Females.**

Methylation status of individual DNA strands in the *H19* ICR in blastocysts derived from spontaneously ovulated females. Maternal, CAST strands are shown. The region of the maternal CAST *H19* allele analyzed contains 17 CpGs. Details are as described in Supplementary Figure 2.1.



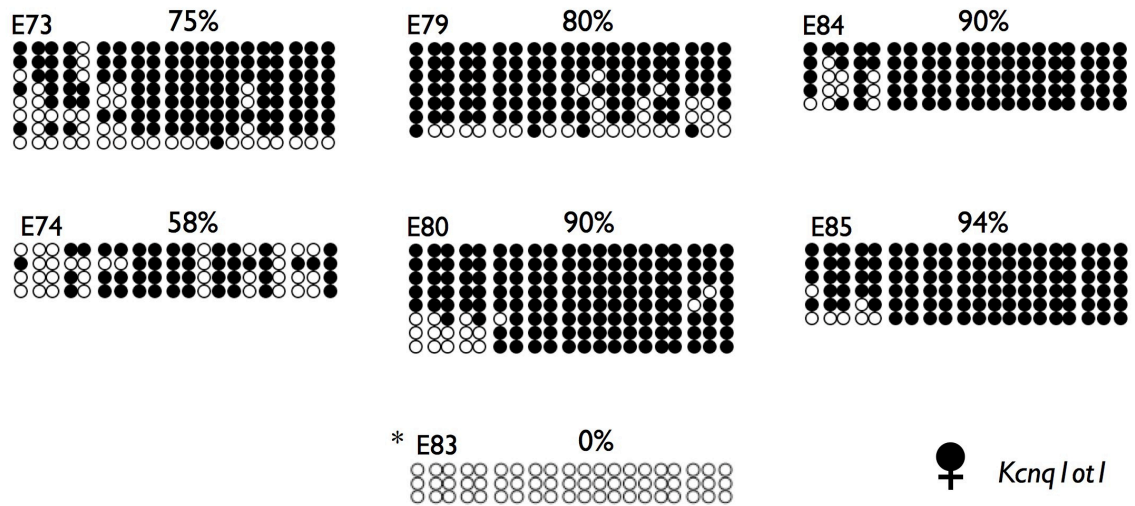
**Supplementary Figure 2.5. Methylation of the Maternal *Snrpn* ICR in B6 X CAST F1 Blastocyst Stage Embryos Derived from Spontaneously Ovulated Females.**

Methylation status of individual DNA strands in the *Snrpn* ICR (maternal, B6 strands shown) in blastocysts derived from spontaneously ovulated females. The region analyzed contains 16 CpGs. Details are as described in Supplementary Figure 2.1.

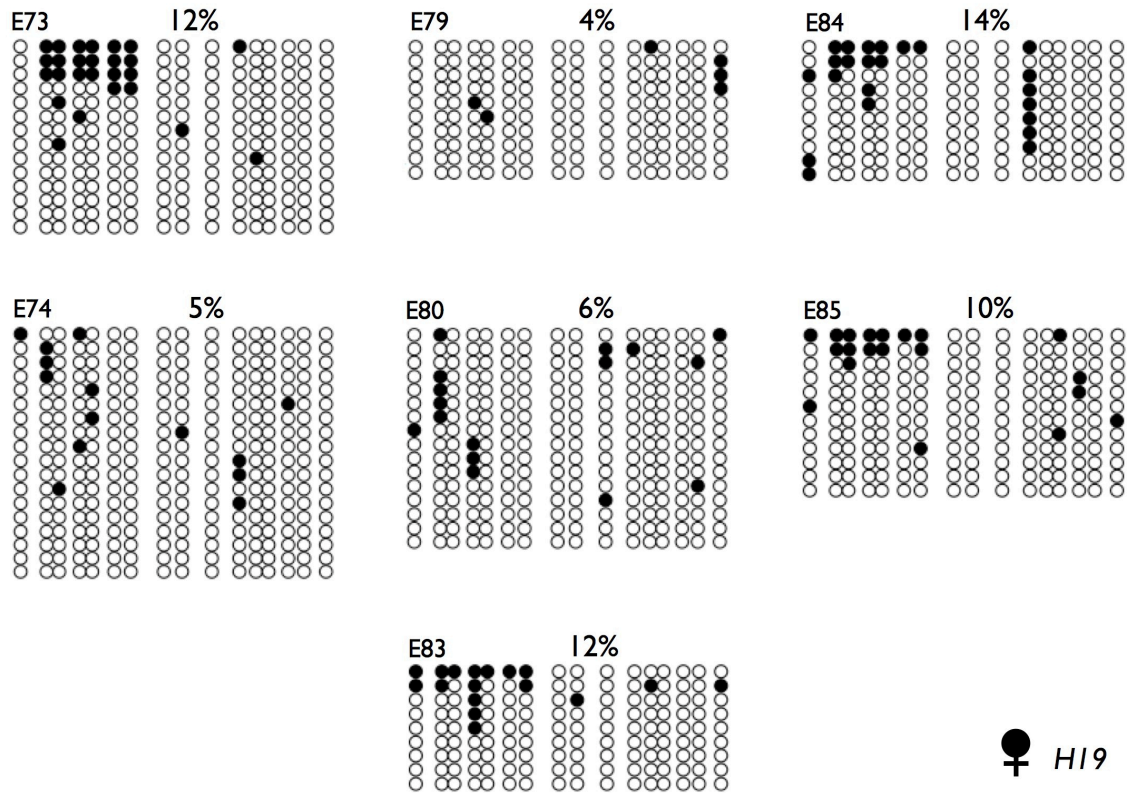


**Supplementary Figure 2.6. Methylation of the Maternal *Peg3* DMR in B6 X CAST F<sub>1</sub> Blastocyst Stage Embryos Derived from Spontaneously Ovulated Females.**

Methylation status of individual DNA strands in the *Peg3* DMR (maternal, B6 strands shown) in blastocysts derived from spontaneously ovulated females. The region analyzed contains 23 CpGs; a polymorphism eliminates CpG 22 on the B6 allele. Details are as described in Supplementary Figure 2.1.

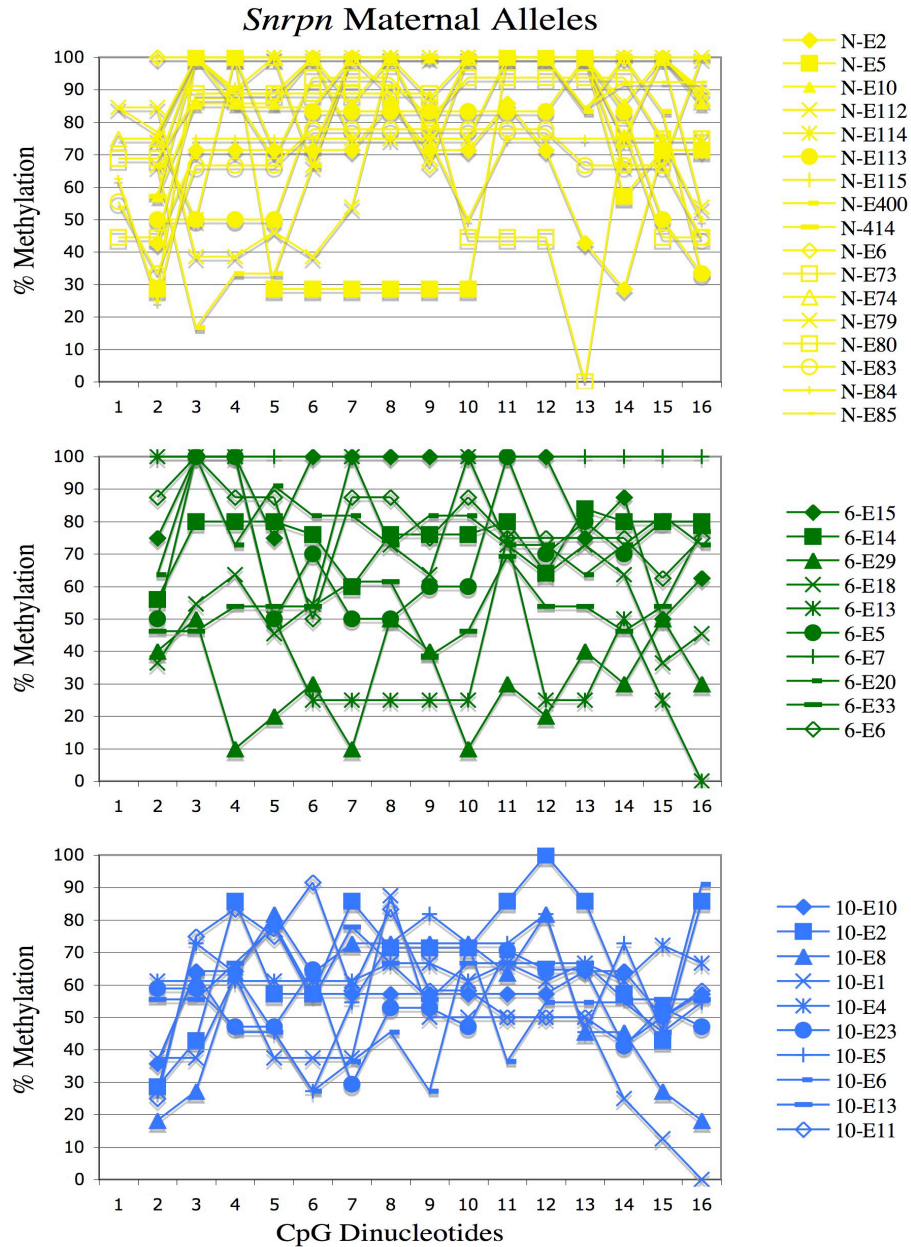


**Supplementary Figure 2.7. Methylation of the Maternal *Kcnq1ot1* ICR in B6 X CAST F<sub>1</sub> Blastocyst Stage Embryos Derived from Spontaneously Ovulated Females.** Methylation status of individual DNA strands in the *Kcnq1ot1* ICR (maternal, B6 strands shown) in blastocysts derived from spontaneously ovulated females. Details are as described in Supplementary Figure 2.1. E83 displayed a reverse pattern of imprinted methylation as indicated by the asterisk (\*).



**Supplementary Figure 2.8. Methylation of the Maternal *H19* ICR in B6 X CAST F<sub>1</sub> Blastocyst Stage Embryos Derived from Spontaneously Ovulated Females.**

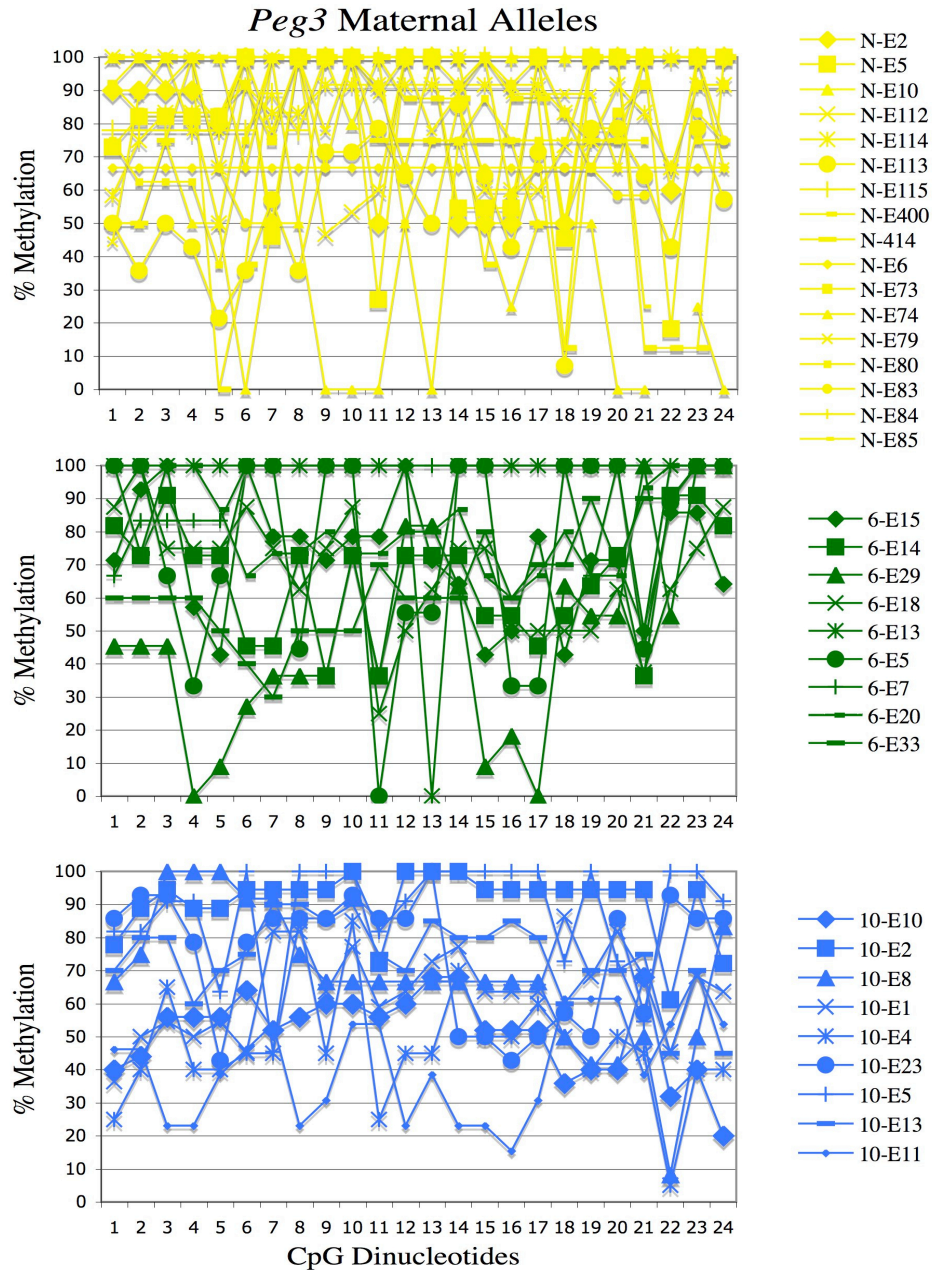
Methylation status of individual DNA strands in the *H19* upstream ICR (maternal, B6 strands shown) in blastocysts derived from spontaneously ovulated females. Details are as described in Supplementary Figure 2.1. The region of the maternal B6 *H19* allele analyzed contains 16 CpGs due to a polymorphism that eliminates CpG 8.



**Supplementary Figure 2.9. Comparison of CpG Methylation Levels of the Maternal *Snrpn* ICR in Embryos Derived from Spontaneously and Induced Ovulated Females.**

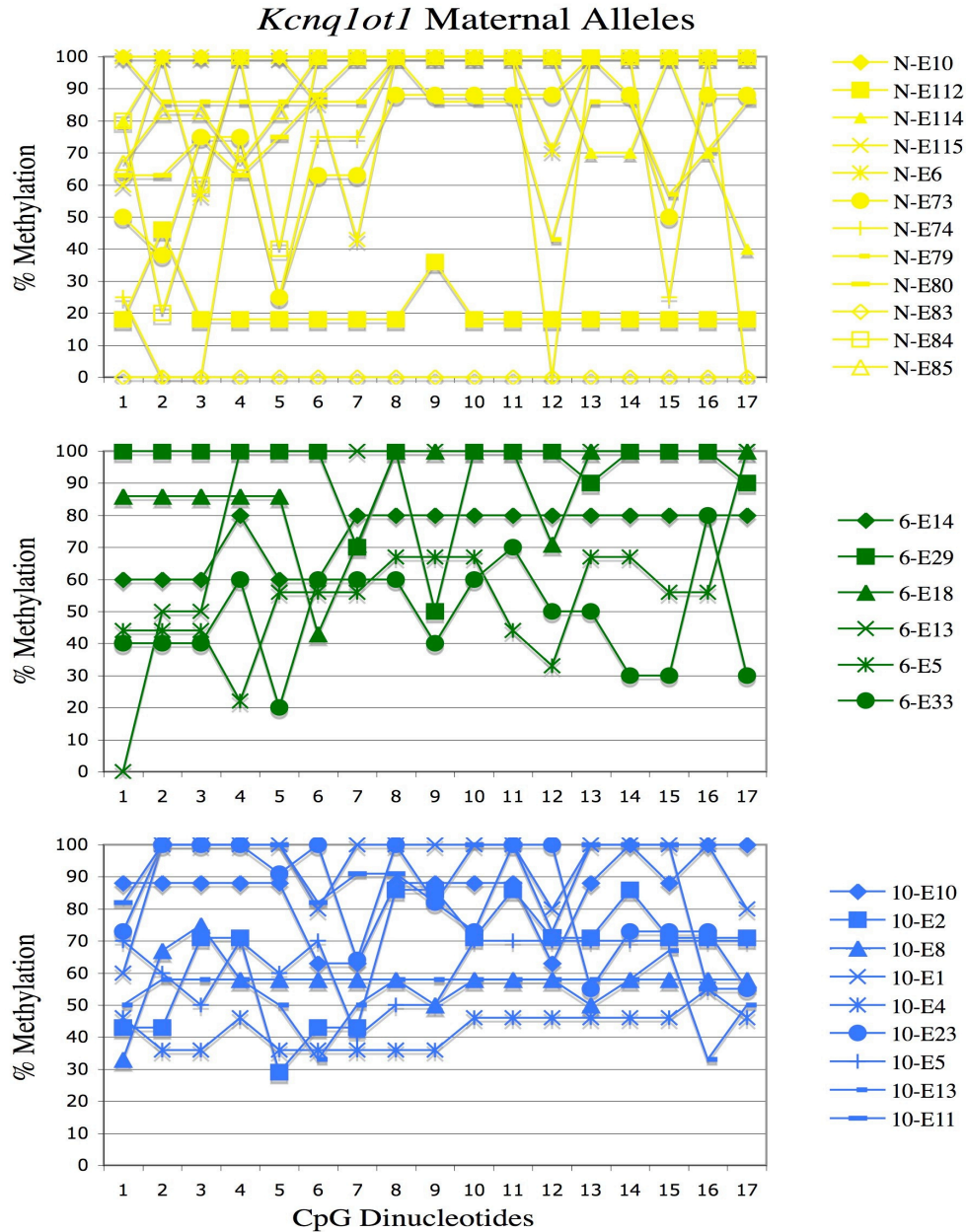
Percent methylation at each individual CpG dinucleotide was calculated as the number of methylated CpGs / total number of CpG dinucleotides, and is represented graphically; top (yellow) embryos derived from spontaneously ovulated females; middle (green) embryos from low dosage superovulated females; and bottom (blue) embryos from high dosage superovulated females. A reduction in CpG methylation was observed in the hormone treatment groups. The region analyzed contains 16 CpGs. A base pair change in the maternal CAST allele eliminates CpG dinucleotide 1 in B6(CAST7) X B6 F<sub>1</sub> Embryos.





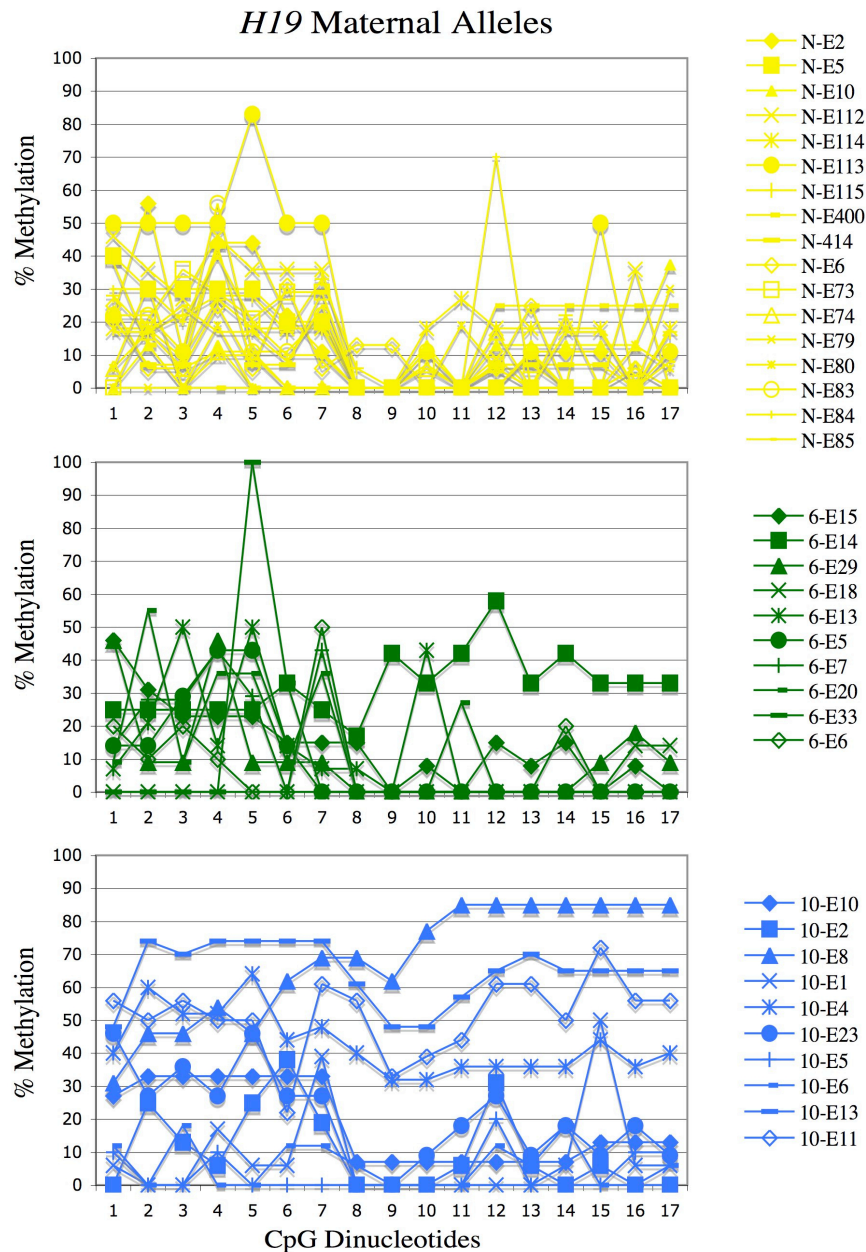
**Supplementary Figure 2.10. Comparison of CpG Methylation Levels of the Maternal *Peg3* DMR in Embryos Derived from Spontaneously and Induced Ovulated Females.**

Percent methylation at each individual CpG dinucleotide was calculated as the number of methylated CpGs / total number of CpG dinucleotides, and is represented graphically; top (yellow) embryos derived from spontaneously ovulated females; middle (green) embryos from low dosage superovulated females; and bottom (blue) embryos from high dosage superovulated females. A shift in CpG methylation was observed with lower methylation levels in the hormone treatment groups. The region analyzed contains 23 CpGs; a polymorphism eliminates CpG 22 on the maternal B6 allele in B6 X CAST F<sub>1</sub> Embryos.



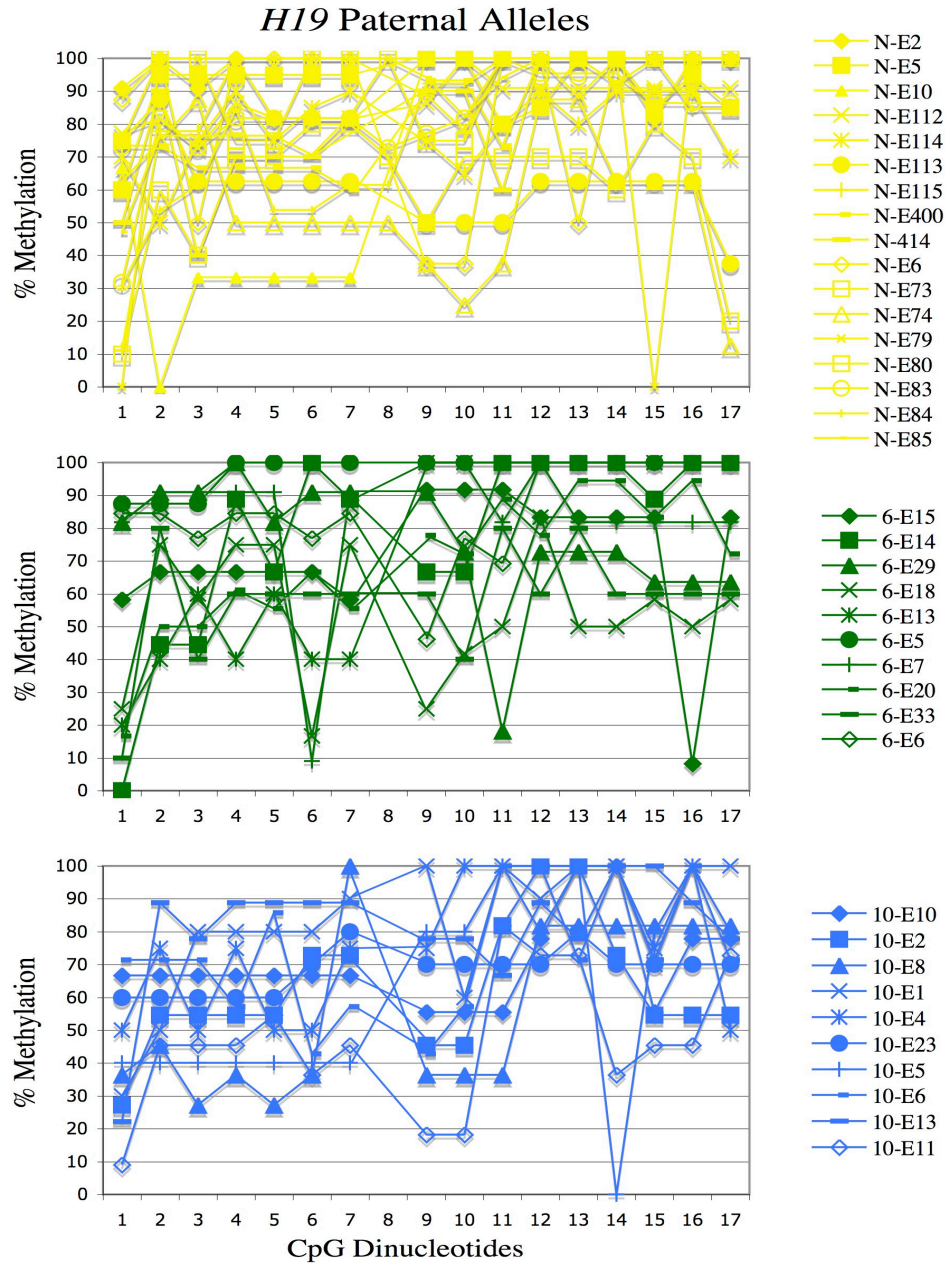
**Supplementary Figure 2.11. Comparison of CpG Methylation Levels of the Maternal *Kcnq1ot1* ICR in Embryos Derived from Spontaneously and Induced Ovulated Females.**

Percent methylation at each individual CpG dinucleotide was calculated as the number of methylated CpGs / total number of CpG dinucleotides, and is represented graphically; top (yellow) embryos derived from spontaneously ovulated females; middle (green) embryos from low dosage superovulated females; and bottom (blue) embryos from high dosage superovulated females. A downward shift in CpG methylation was observed in the hormone treatment groups. The region analyzed contains 20 CpGs.



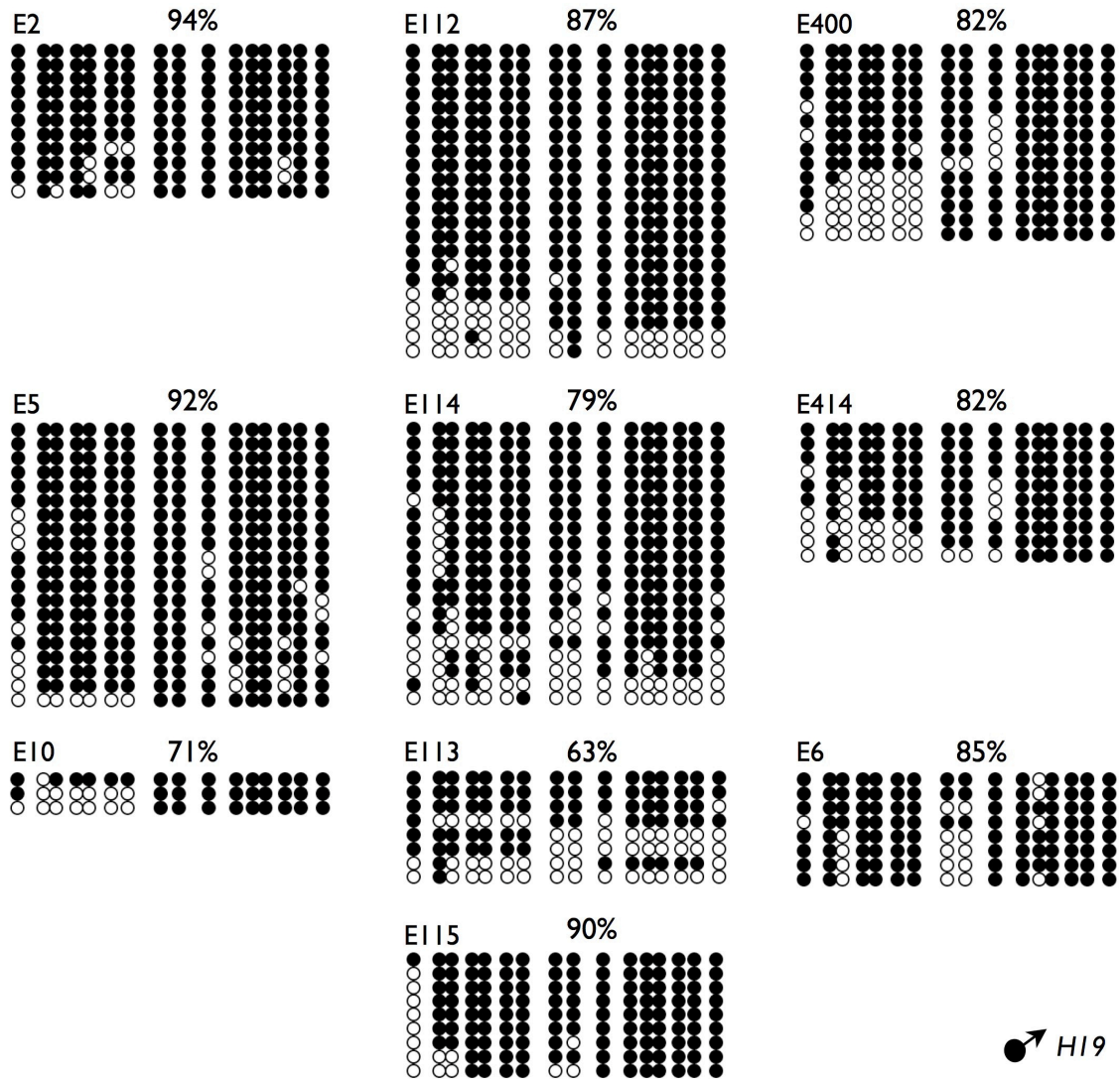
**Supplementary Figure 2.12. Comparison of CpG Methylation Levels of the Maternal *H19* ICR in Embryos Derived from Spontaneously and Induced Ovulated Females.**

Percent methylation at each individual CpG dinucleotide was calculated as the number of methylated CpGs / total number of CpG dinucleotides, and is represented graphically; top (yellow) embryos derived from spontaneously ovulated females; middle (green) embryos from low dosage superovulated females; and bottom (blue) embryos from high dosage superovulated females. A gain in CpG methylation was observed in the hormone treatment groups. The region analyzed contains 17 CpGs; a polymorphism eliminates CpG 8 on the maternal B6 allele in B6 X CAST F<sub>1</sub> Embryos.



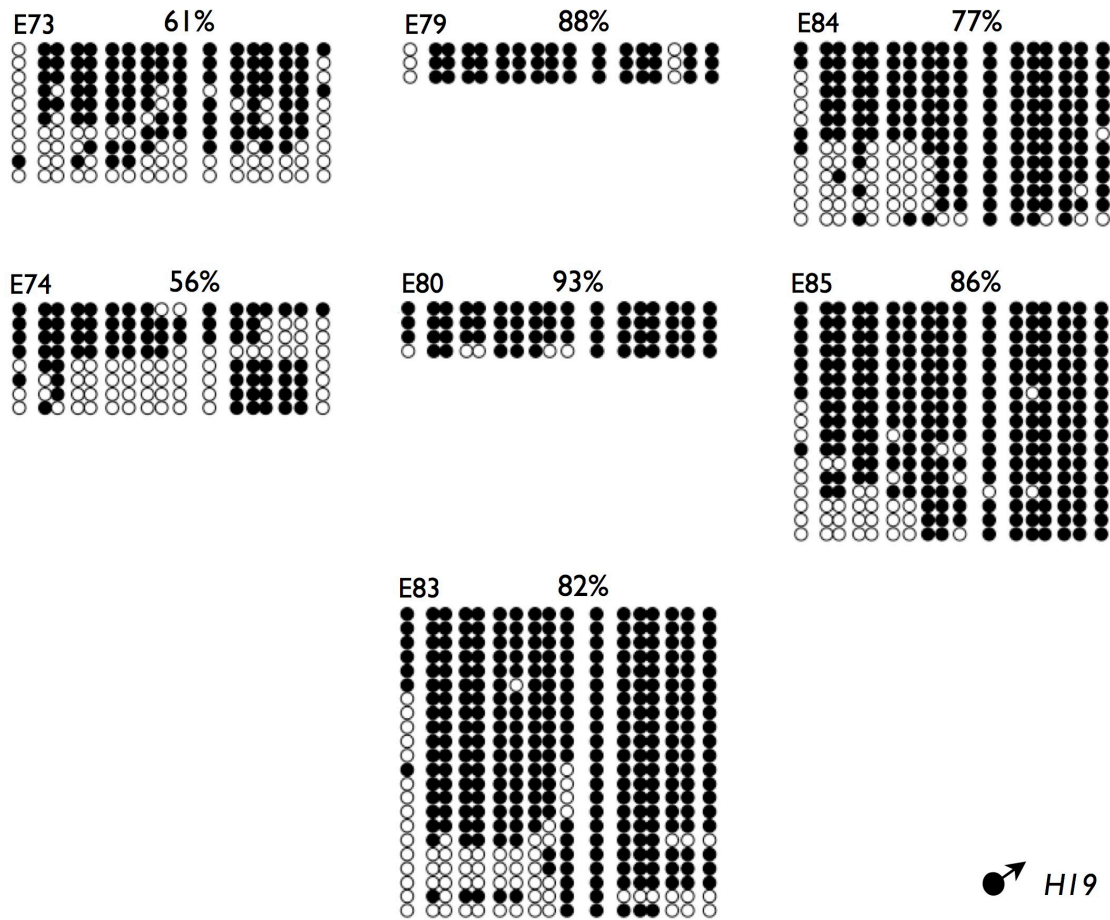
**Supplementary Figure 2.13. Comparison of CpG Methylation Levels of the Paternal *H19* ICR in Embryos Derived from Spontaneously and Induced Ovulated Females.**

Percent methylation at each individual CpG dinucleotide was calculated as the number of methylated CpGs / total number of CpG dinucleotides, and is represented graphically; top (yellow) embryos derived from spontaneously ovulated females; middle (green) embryos from low dosage superovulated females; and bottom (blue) embryos from high dosage superovulated females. A shift in CpG methylation was observed with lower methylation levels in the hormone treatment groups. The region analyzed contains 17 CpGs; a polymorphism eliminates CpG 8 on the paternal B6 allele in B6(CAST7) X B6 F<sub>1</sub> Embryos.



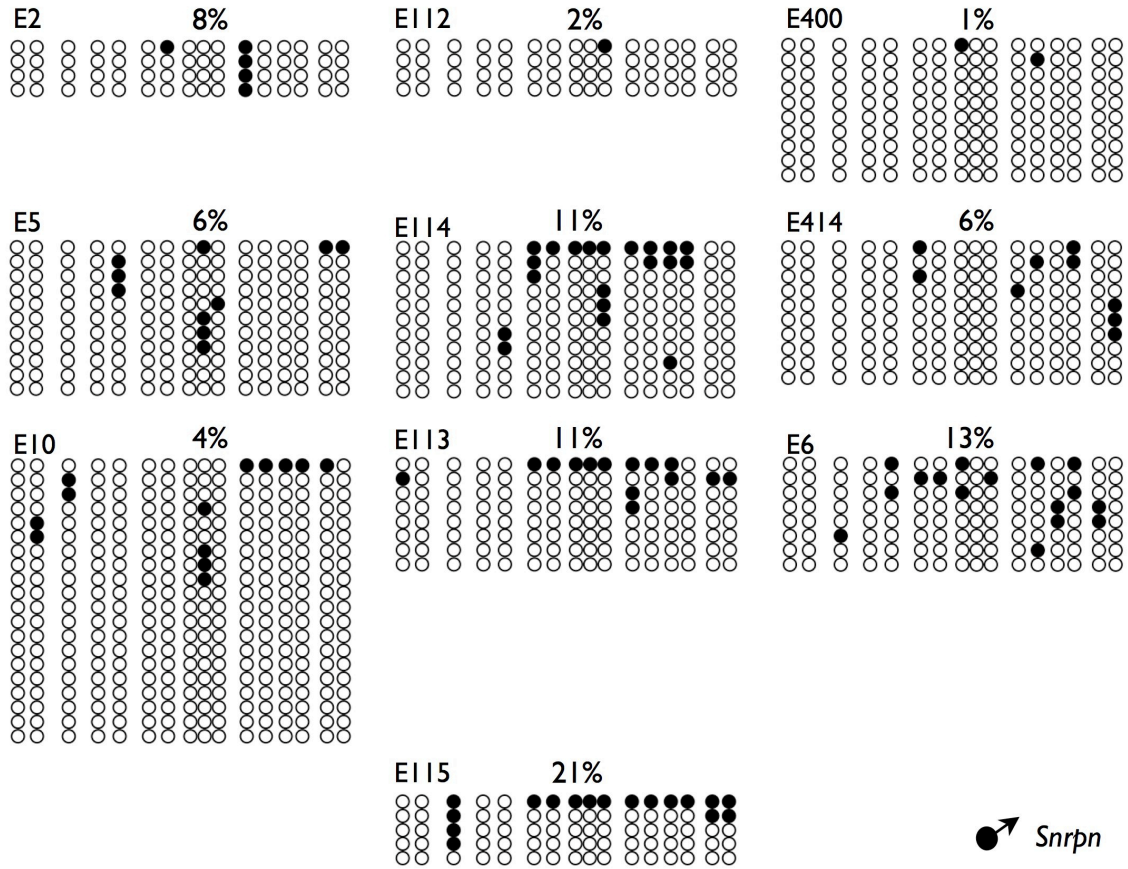
**Supplementary Figure 2.14. Methylation of the Paternal *H19* ICR in B6(CAST7) X B6 F<sub>1</sub> Embryos Derived from Spontaneously Ovulated Females.**

Methylation status of individual DNA strands in the *H19* upstream ICR (paternal, B6 strands shown) in blastocysts derived from spontaneously ovulated females. Details are as described in Supplementary Figure 2.1. The region of the paternal B6 *H19* allele analyzed contains 16 CpGs due to a polymorphism that eliminates CpG 8.



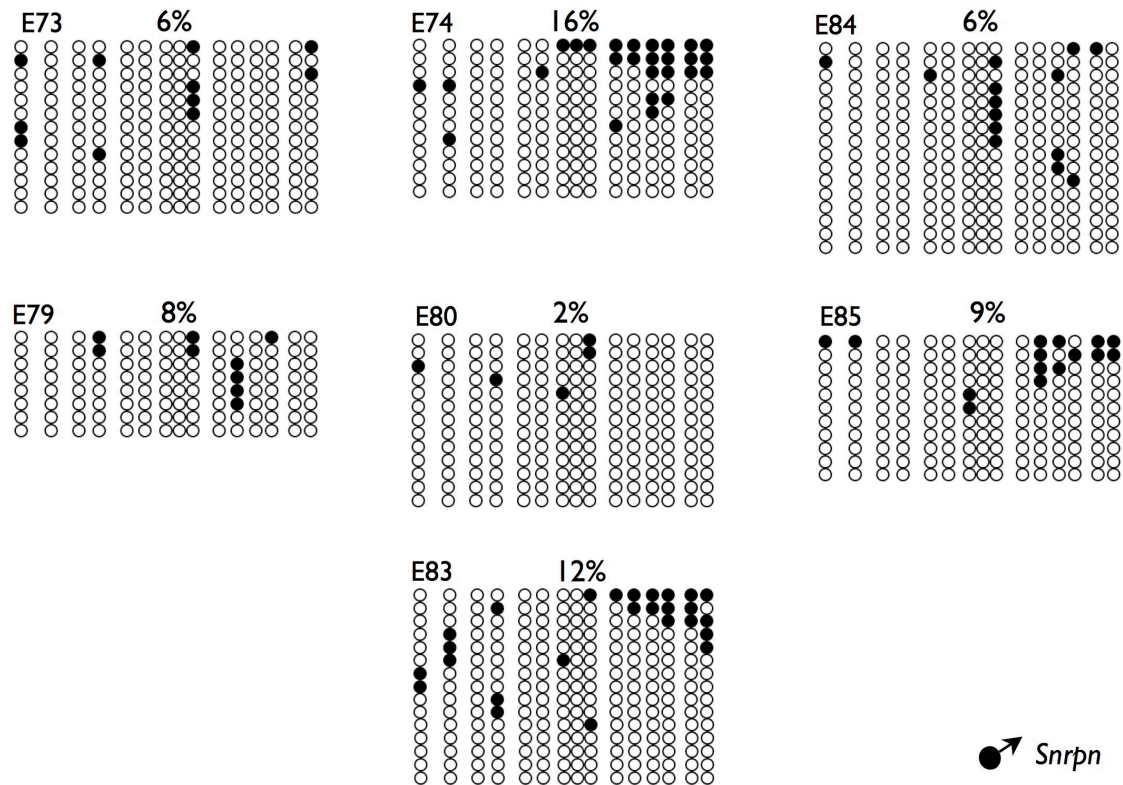
**Supplementary Figure 2.15. Methylation of the Paternal *H19* ICR in B6 X CAST F<sub>1</sub> Embryos Derived from Spontaneously Ovulated Females.**

Methylation status of individual DNA strands in the *H19* upstream ICR (paternal, CAST strands shown) in blastocysts derived from spontaneously ovulated females. Details are as described in Supplementary Figure 2.1. The region of the paternal CAST *H19* allele analyzed contains 17 CpGs.



**Supplementary Figure 2.16. Methylation of the Paternal *Snrpn* ICR in B6(CAST7) X B6 F<sub>1</sub> Embryos Derived from Spontaneously Ovulated Females.**

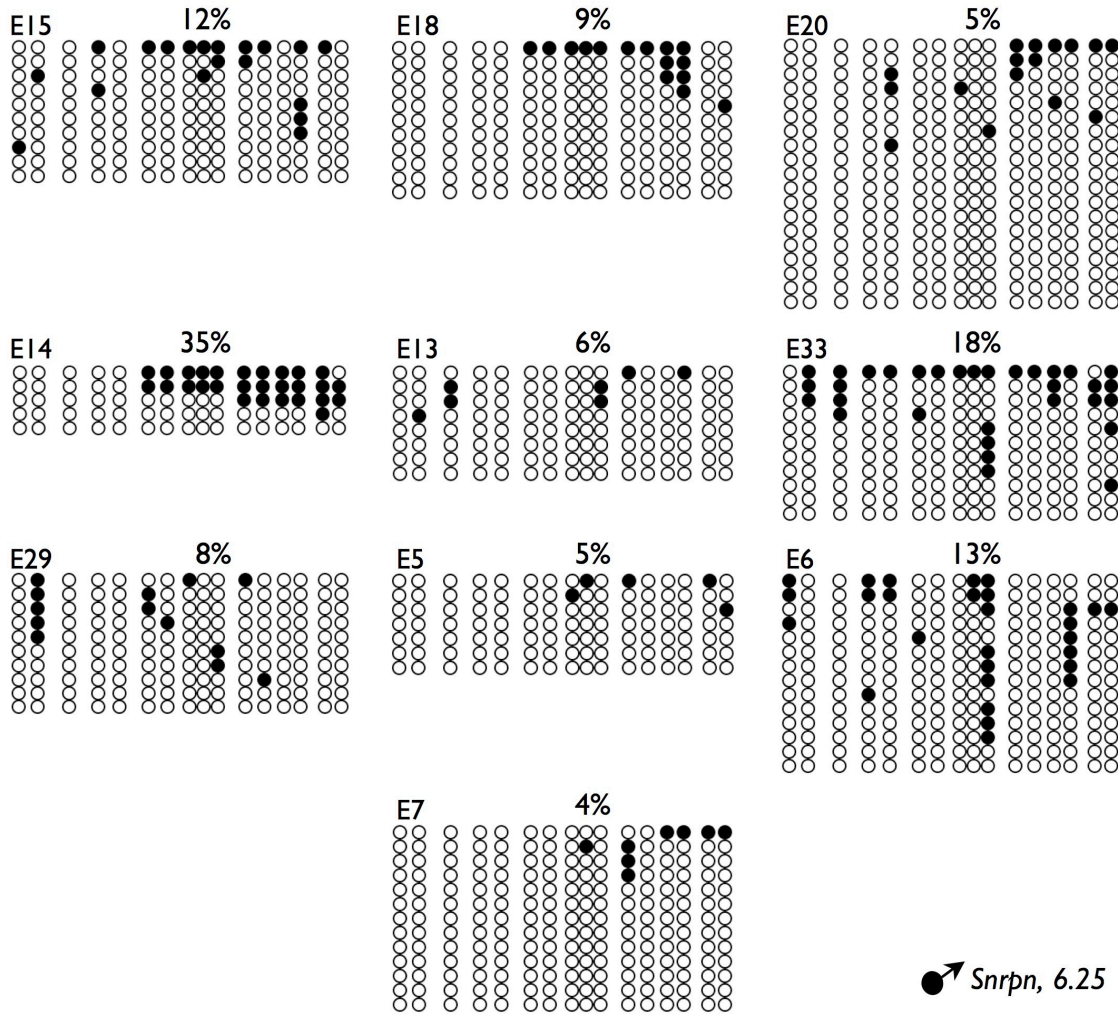
Methylation status of individual DNA strands in the *Snrpn* ICR (paternal, B6 strands shown) in blastocysts derived from spontaneously ovulated females. The region analyzed contains 16 CpGs. Details are as described in Supplementary Figure 2.1.



**Supplementary Figure 2.17. Methylation of the Paternal *Snrpn* ICR in B6 X CAST F<sub>1</sub> Embryos Derived from Spontaneously Ovulated Females.**

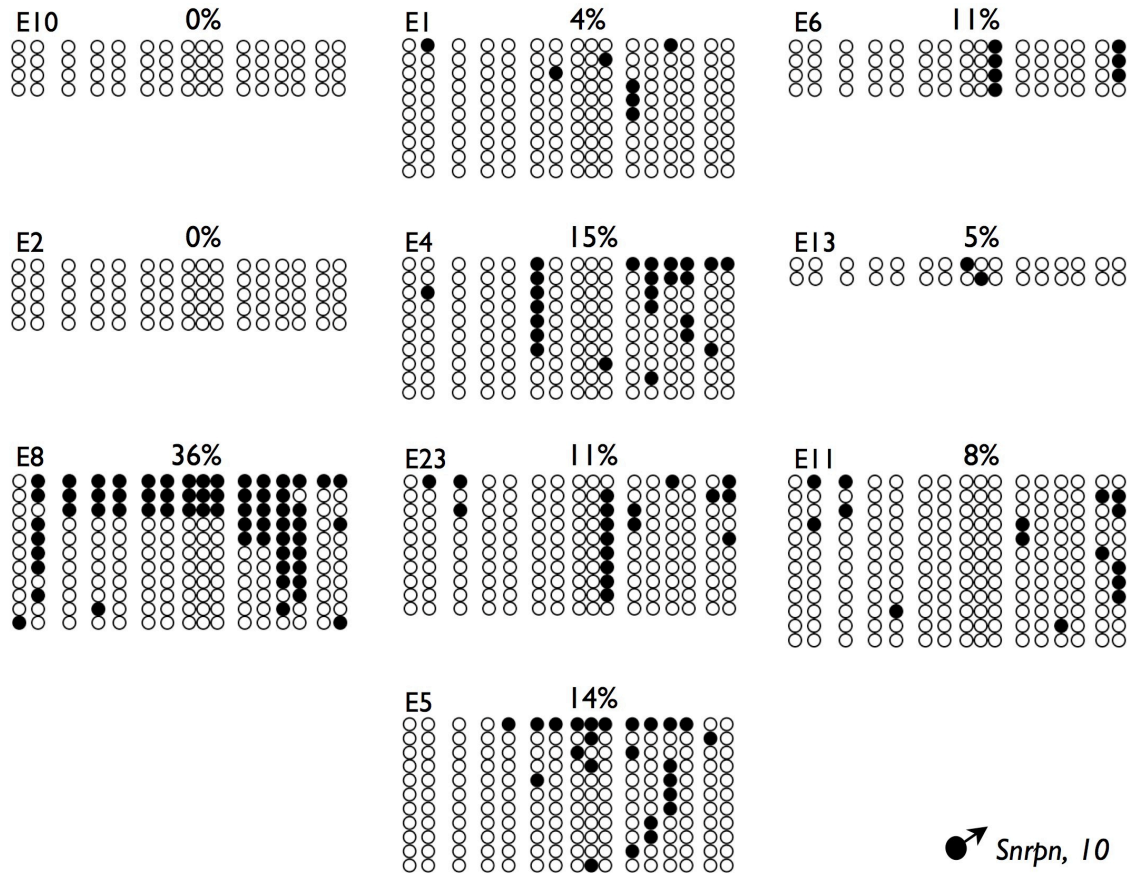
Methylation status of individual DNA strands in the *Snrpn* ICR (paternal, CAST strands shown) in blastocysts derived from spontaneously ovulated females. The region analyzed contains 15 CpGs; a base pair change in the paternal CAST allele eliminates CpG dinucleotide 1. Details are as described in Supplementary Figure 2.1.





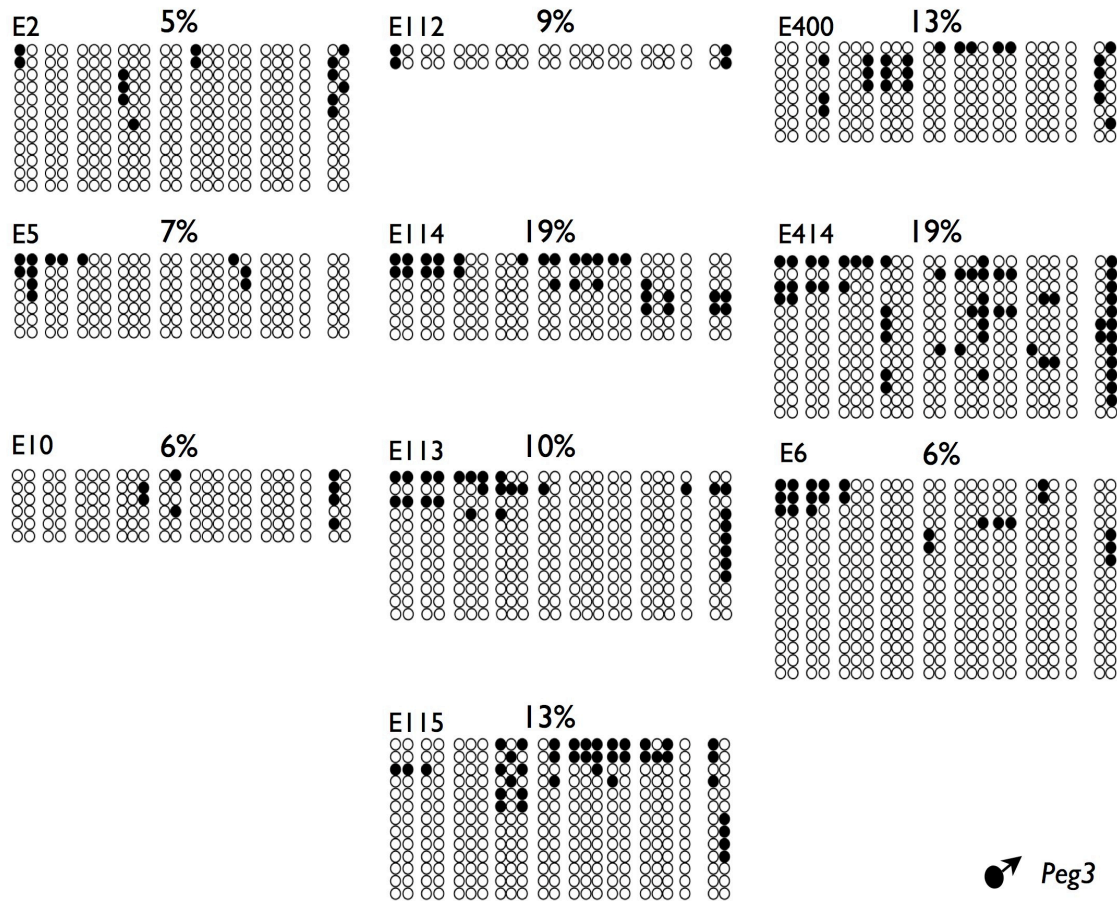
**Supplementary Figure 2.18. Methylation of the Paternal *Snrpn* ICR in B6(CAST7) X B6 F<sub>1</sub> Embryos Derived from Low Dosage Superovulated Females.**

Methylation status of individual DNA strands in the *Snrpn* ICR (paternal, B6 strands shown) in blastocysts derived from females superovulated with a 6.25 IU hormone dosage. The region analyzed contains 16 CpGs. Details are as described in Supplementary Figure 2.1.



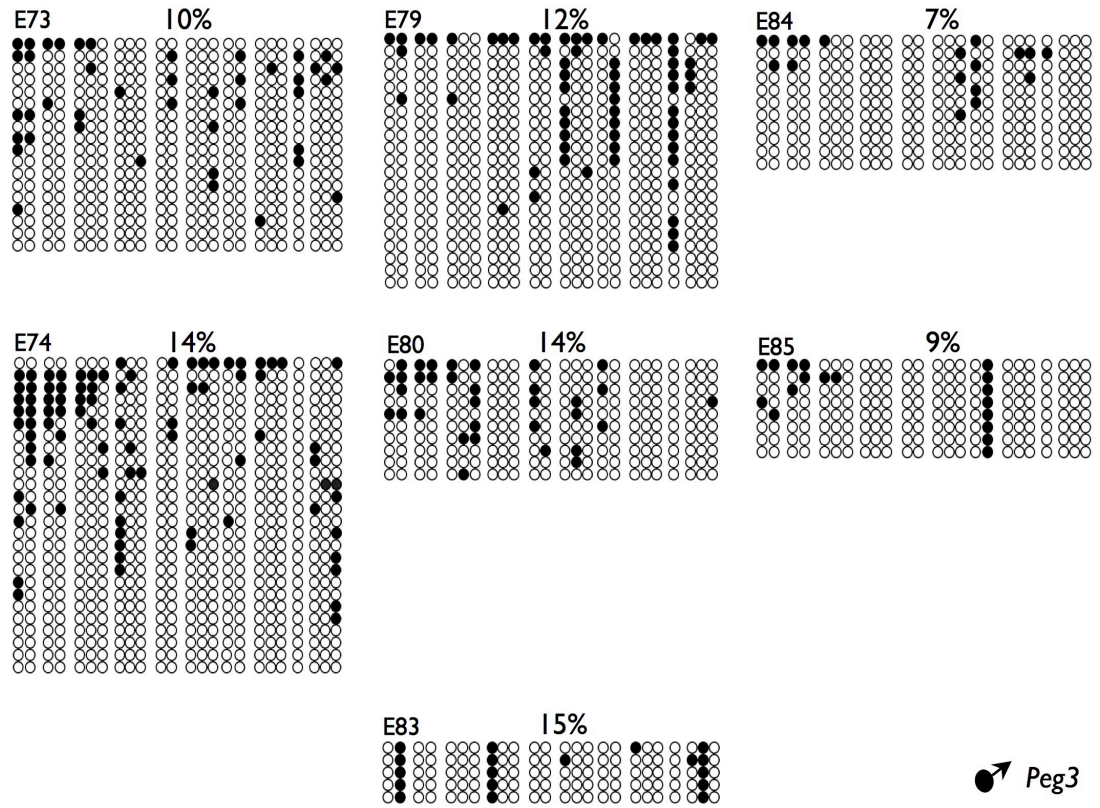
**Supplementary Figure 2.19. Methylation of the Paternal *Snrpn* in B6(CAST7) X B6 F<sub>1</sub> Embryos Derived from High Dosage Superovulated Females.**

Methylation status of individual DNA strands in the *Snrpn* (paternal, B6 strands shown) in blastocysts derived from females superovulated with a 10 IU hormone dosage. The region analyzed contains 16 CpGs. Details are as described in Supplementary Figure 2.1.



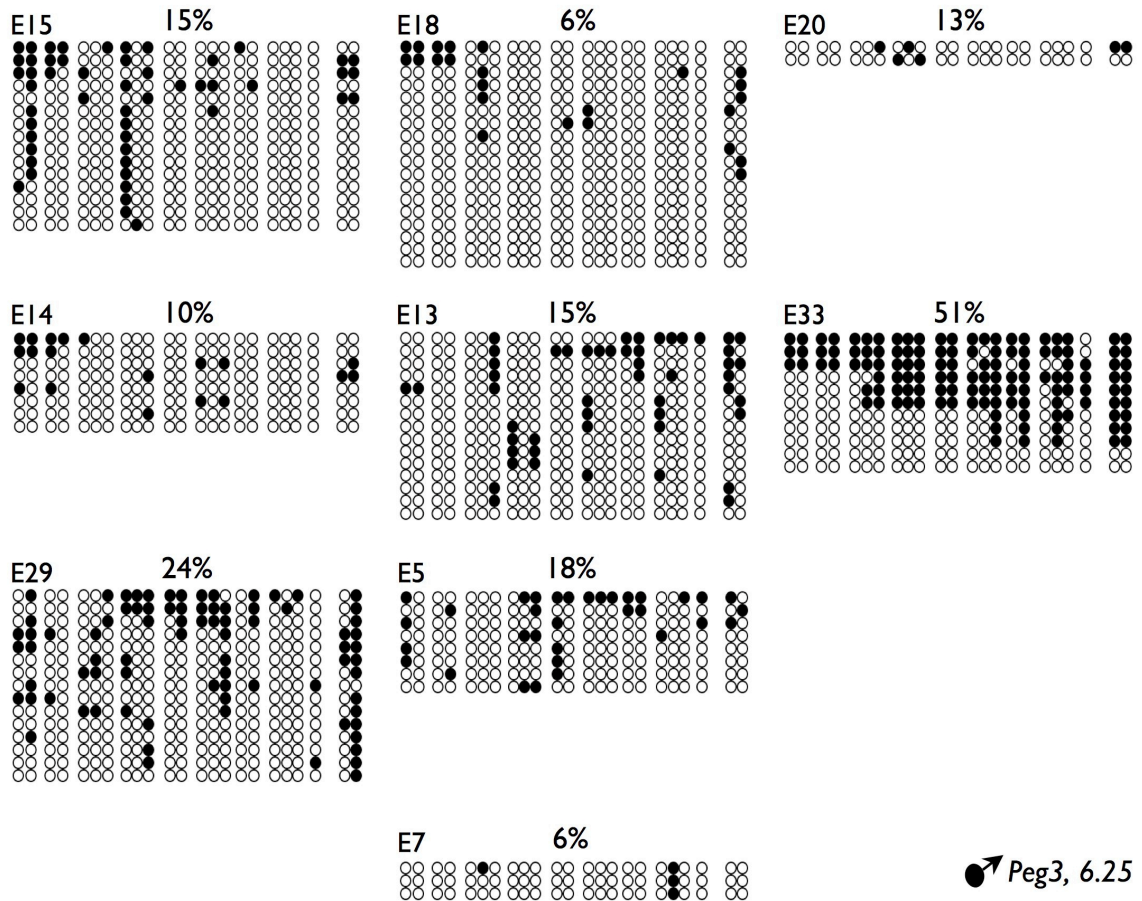
**Supplementary Figure 2.20. Methylation of the Paternal *Peg3* DMR in B6(CAST7) X B6 F<sub>1</sub> Embryos Derived from Spontaneously Ovulated Females.**

Methylation status of individual DNA strands in the *Peg3* DMR (paternal, B6 strands shown) in blastocysts derived from spontaneously ovulated females. The region analyzed contains 23 CpGs; a polymorphism eliminates CpG 22 on the B6 allele. Details are as described in Supplementary Figure 2.1.



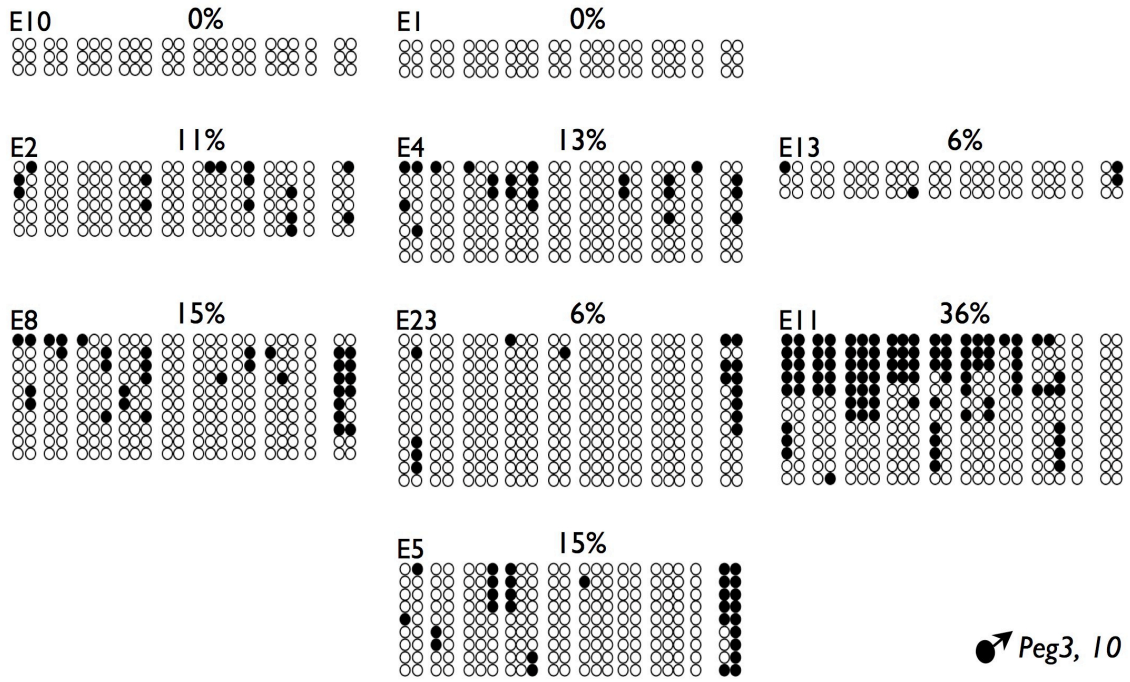
**Supplementary Figure 2.21. Methylation of the Paternal *Peg3* DMR in B6 X CAST F<sub>1</sub> Embryos Derived from Spontaneously Ovulated Females.**

Methylation status of individual DNA strands in the *Peg3* DMR (paternal, CAST strands shown) in blastocysts derived from spontaneously ovulated females. The region analyzed contains 24 CpGs. Details are as described in Supplementary Figure 2.1.



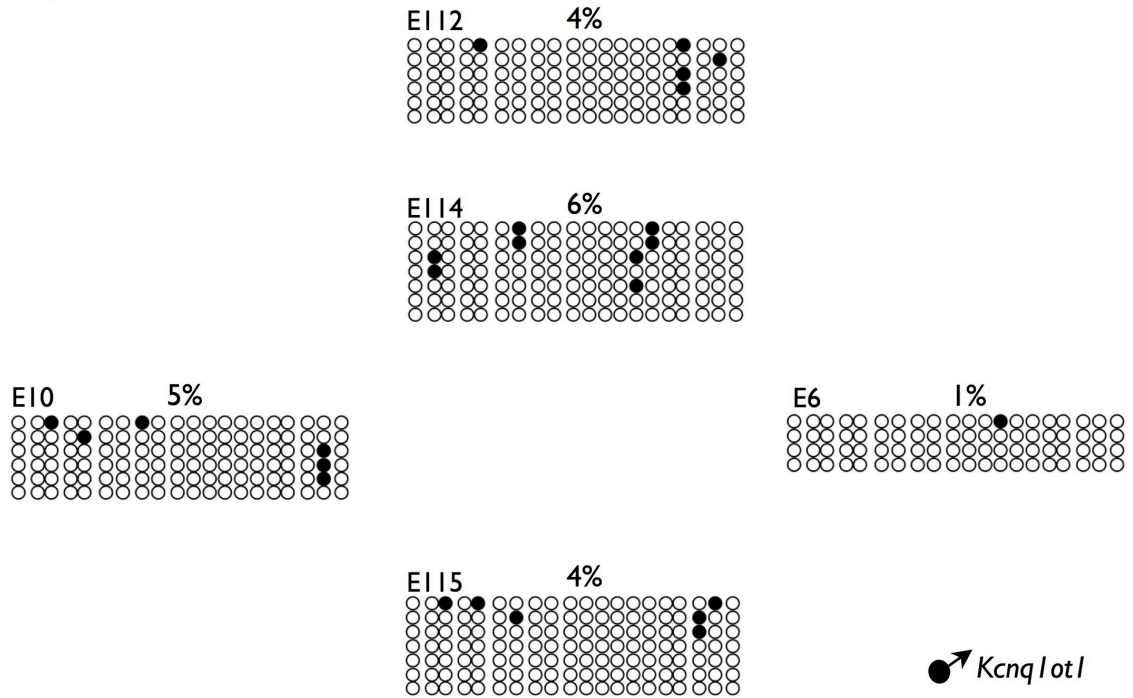
**Supplementary Figure 2.22. Methylation of the Paternal *Peg3* DMR in B6(CAST7) X B6 F<sub>1</sub> Embryos Derived from Low Dosage Superovulated Females.**

Methylation status of individual DNA strands in the *Peg3* DMR (paternal, B6 strands shown) in blastocysts derived from females superovulated with a 6.25 IU hormone dosage. The region analyzed contains 23 CpGs; a polymorphism eliminates CpG 22 on the B6 allele. Details are as described in Supplementary Figure 2.1.

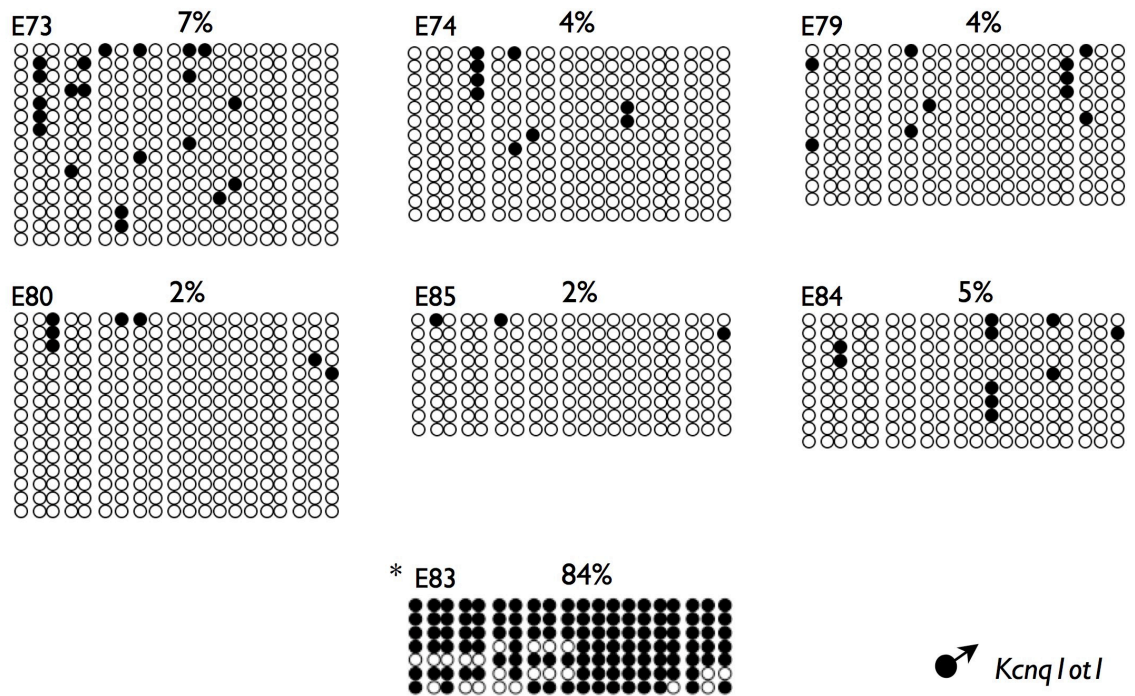


**Supplementary Figure 2.23. Methylation of the Paternal *Peg3* DMR in B6(CAST7) X B6 F<sub>1</sub> Embryos Derived from High Dosage Superovulated Females.**

Methylation status of individual DNA strands in the *Peg3* DMR (paternal, B6 strands shown) in blastocysts derived from females superovulated with a 10 IU hormone dosage. The region analyzed contains 23 CpGs; a polymorphism eliminates CpG 22 on the B6 allele. Details are as described in Supplementary Figure 2.1.



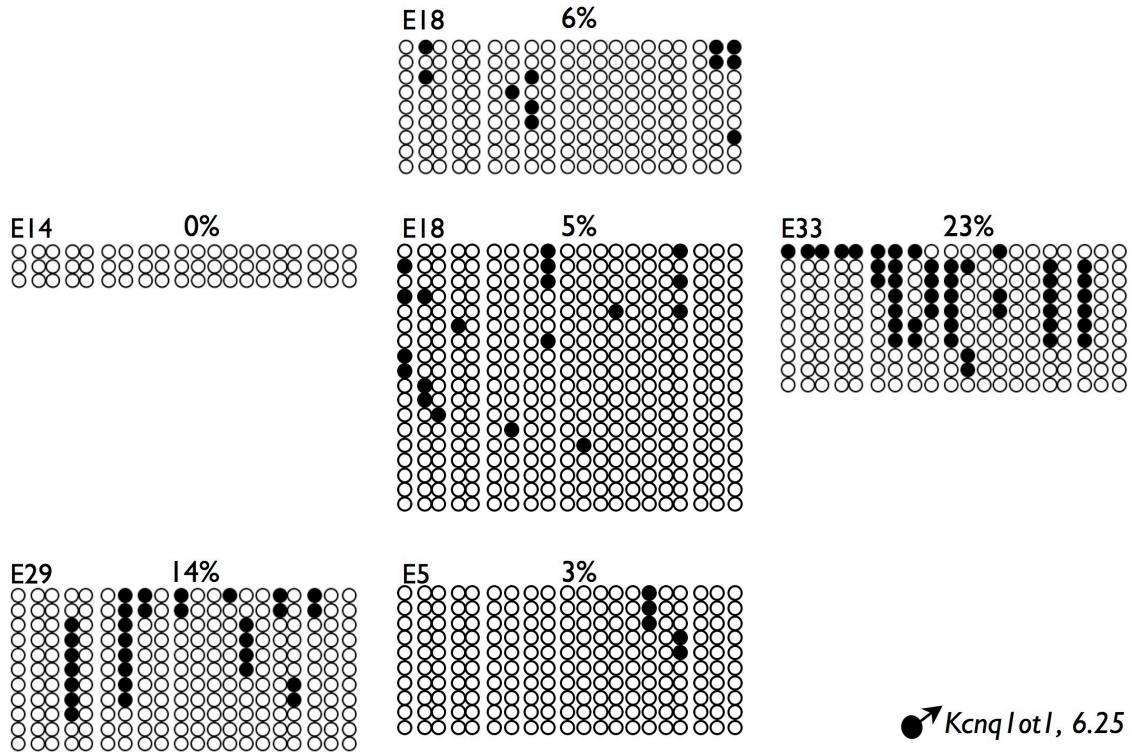
**Supplementary Figure 2.24. Methylation of the Paternal *Kcnq1ot1* ICR in B6(CAST7) X B6 F<sub>1</sub> Embryos Derived from Spontaneously Ovulated Females.** Methylation status of individual DNA strands in the *Kcnq1ot1* ICR (paternal, B6 strands shown) in blastocysts derived from spontaneously ovulated females. Details are as described in Supplementary Figure 2.1.



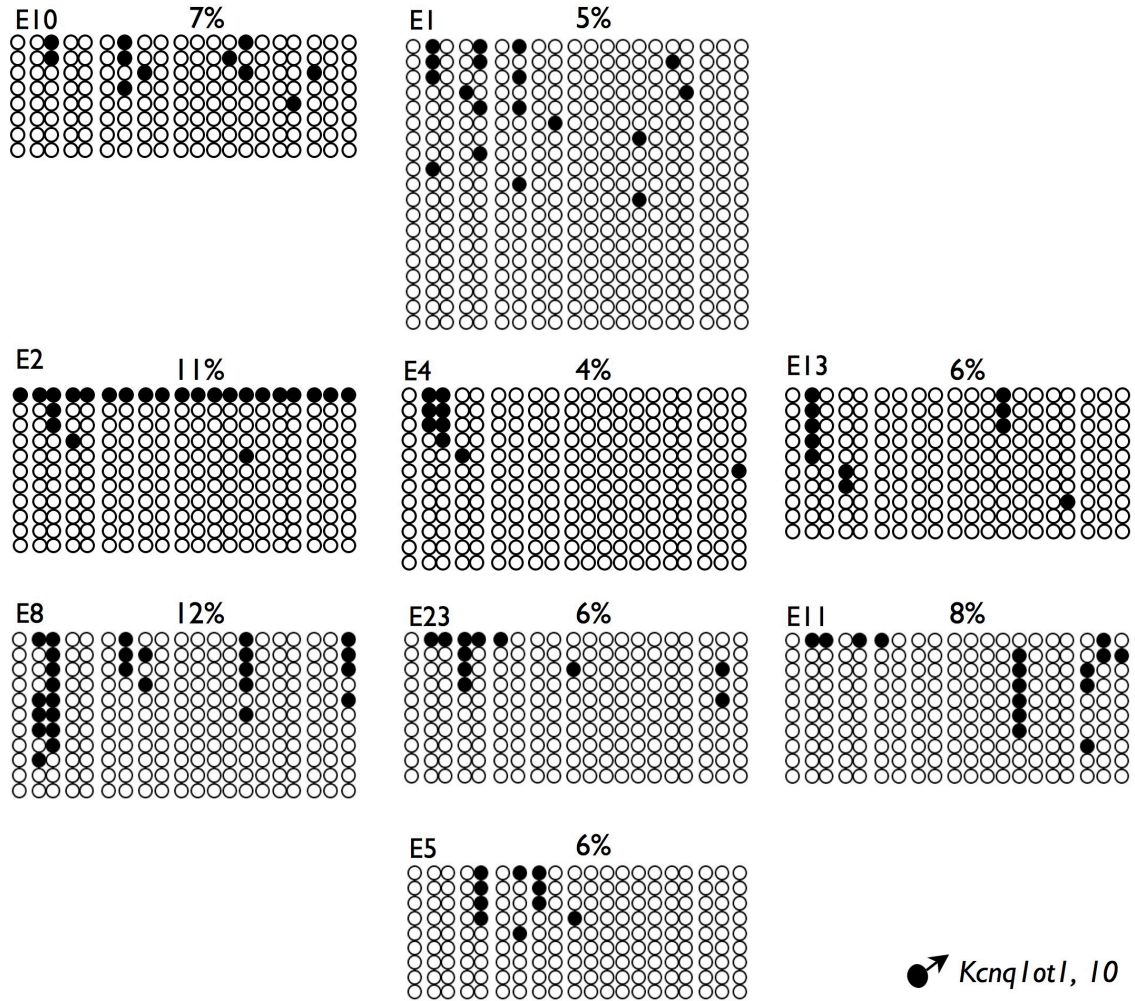
**Supplementary Figure 2.25. Methylation of the Paternal *Kcnq1ot1* ICR in B6 X CAST F<sub>1</sub> Embryos Derived from Spontaneously Ovulated Females.**

Methylation status of individual DNA strands in the *Kcnq1ot1* ICR (paternal, CAST strands shown) in blastocysts derived from spontaneously ovulated females. Details are as described in Supplementary Figure 2.1. E83 displayed a reverse pattern of imprinted methylation as indicated by the asterisk (\*).





**Supplementary Figure 2.26. Methylation of the Paternal *Kcnq1ot1* ICR in B6(CAST7) X B6 F<sub>1</sub> Embryos Derived from Low Dosage Superovulated Females.** Methylation status of individual DNA strands in the *Kcnq1ot1* ICR (paternal, B6 strands shown) in blastocysts derived from females superovulated with a 6.25 IU hormone dosage. Details are as described in Supplementary Figure 2.1.



**Supplementary Figure 2.27. Methylation of the Paternal *Kcnq1ot1* ICR in B6(CAST7) X B6 F<sub>1</sub> Embryos Derived from High Dosage Superovulated Females.**  
 Methylation status of individual DNA strands in the *Kcnq1ot1* ICR (paternal, B6 strands shown) in blastocysts derived from females superovulated with a 10 IU hormone dosage. Details are as described in Supplementary Figure 2.1.

#### **Appendix 4: Supplementary Material - Chapter 3**

The following figures were presented as supplementary data in the following peer-reviewed article:

Market-Velker, B. A., Fernandes, A. D. and Mann, M. R. Side-by-side comparison of five commercial media systems in a mouse model: suboptimal in vitro culture interferes with imprint maintenance. *Biol Reprod* 83(6): 938-50 (2010)

Supplementary Table 3.1: Regions and Conditions for PCR Analysis for Imprinted Methylation and Expression

Gene	Accession	Primer /Probe	Primer Sequence (5'-3')	Annealing Temp	Reference
<b>Imprinted Methylation Analysis</b>					
<i>H19</i>	U19619	OF	GAG TAT TTA GGA GGT ATA AGA ATT	55	Mann et al., 2004; Market-Velker et al., 2010
		OR	ATC AAA AAC TAA CAT AAA CCT CT		
		IF	GTA AGG AGA TTA TGT TTA TTT TTG G	50	
		IR	CCT CAT TAA TCC CAT AAC TAT		
<i>Snrpn</i>	AF081460	OF	TAT GTA ATA TGA TAT AGT TTA GAA ATT AG	52	Mann et al., 2004; Market-Velker et al., 2010
		OR	AAT AAA CCC AAA TCT AAA ATA TTT TAA TC		
		IF	AAT TTG TGT GAT GTT TGT AAT TAT TTG G	54	
		IR	ATA AAA TAC ACT TTC ACT ACT AAA ATC C		
<i>Peg3</i>	NT_039413.7	OF	TTT TGA TAA GGA GGT GTT T	50	Mann et al., 2004; Market-Velker et al., 2010
		OR	ACT CTA ATA TCC ACT ATA ATA A		
		IF	AGT GTG GGT GTA TTA GAT T	53	
		IR	TAA CAA AAC TTC TAC ATC ATC		
<b>Imprinted Expression Analysis</b>					
<i>H19</i>	AF049091	F	CCT CAA GAT GAA AGA AAT GGT	55	Mann et al., 2004
		R	AA CAC TTT ATG ATG GAA CTG C		
		Sensor <sup>a</sup>	CCA CCT GTC GTC CAT CTC C-FL	52	
		Anchor	LC640-TCT GAG GGC AAC TGG GTG TGG-P		
<i>Snrpn</i>	MMSMN	F	CTC CAC CAG GAA TTA GAG GC	52	Mann et al., 2004
		R	TAT AGT TAA TGC AGT AAG AGG		
		Sensor	GAA GCA TTG TAG GGG AAG AGA A-FL	53	
		Anchor	LC640-GGC TGA GAT TTA TCA ACT GTA TCT TAG GGT C-P		
<i>Peg3</i>	AF038939	F	CAG GAG AAA GTT GAA GAT GCT AC	53	This study
		R	TTC GTG AAC TCT CTG GTG CT		
		Sensor <sup>a</sup>	CCA GAG CAC TTT TTC TCA AAT TCG-FL	53	
		Anchor	LC640-TGA CGG AGT GGG CAT GAA CTT CAG-P		

OF Outer Forward, OR Outer Reverse, IF Inner Forward, IR Inner Reverse, F Forward, R Reverse, <sup>a</sup>Sensor and Anchor Probes were purchased from TIB MolBiol.

Supplementary Table 3.2: Ability of Media System to Support Development to the Blastocyst Stage

<b>Experimental Group<sup>a</sup></b>	<b>2-Cell</b>	<b># Blastocyst<sup>b</sup></b>	<b>% Blastocyst<sup>c</sup></b>
Whittens	56	54	96
KSOMaa	54	53	98
HTF	56	51	91
Global	72	70	97
P1/MB	53	49	92
G1.5/G2.5	44	44	100
6.25 IU/Whittens	50	46	92
6.25 IU/KSOMaa	50	48	96
6.25 IU/HTF	38	34	89
6.25 IU/Global	32	31	97
6.25 IU/P1/MB	22	19	86
6.25 IU/G1.5/G2.5	46	44	96

<sup>a</sup>Multiple culture experiments were performed for each group. Data from each group were pooled.

<sup>b</sup>Development to the blastocyst stage was scored before freezing on day 4 (see Figure 1), and was defined as the presence of a blastocoel cavity.

<sup>c</sup>Percent development to the blastocyst stage was calculated as # embryos developed to blastocyst stage / total number of embryos cultured.

Supplementary Table 3.3: Gene and Imprinted Expression Analysis from Embryos Derived from Spontaneously Ovulated Females

Gene	# Analyzed	# Expressed	% Expressed <sup>a</sup>	# LOI	% LOI <sup>b</sup>
<i>H19</i>	68	9	13	0	0
<i>Snrpn</i>	130	130	100	0	0
<i>Peg3</i>	24	23	96	1	4

<sup>a</sup>Percent expressed was calculated as # embryos with gene expressed / total number of embryos analyzed.

<sup>b</sup>Percent LOI was calculated as # embryos with loss of imprinted expression / total number of embryos analyzed.

Supplementary Table 3.4: Statistical Analysis<sup>a</sup> of Imprinted *H19* Expression

	Superovulated <sup>c</sup>	In Vivo	Whittens	KSOMaa	Global	HTF	P1/MB	G1.5/G2.5
Spontaneous <sup>b</sup>								
In Vivo			1.2 x 10 <sup>-11</sup>	1.6 x 10 <sup>-12</sup>	1.6 x 10 <sup>-12</sup>	1.1 x 10 <sup>-13</sup>	9.9 x 10 <sup>-13</sup>	2.1 x 10 <sup>-10</sup>
Whittens		1.2 x 10 <sup>-7</sup>		0.058	0.52	0.27	0.29	0.37
KSOMaa		3.5 x 10 <sup>-11</sup>	0.52		0.76	0.51	0.54	0.22
Global		2.6 x 10 <sup>-9</sup>	0.27	0.26		0.52	0.54	0.22
HTF		8.0 x 10 <sup>-5</sup>	0.18	0.0043	0.040		1.0	0.08
P1/MB		6.8 x 10 <sup>-9</sup>	0.30	0.25	0.61	0.049		0.09
G1.5/G2.5		8.3 x 10 <sup>-10</sup>	0.094	0.64	0.34	0.0096	0.32	

<sup>a</sup>Fisher's exact test was used to compute the significance in number of embryos with imprinted and nonimprinted *H19* expression between groups. P<0.05 was considered statistically significant.

<sup>b</sup>Purple, bottom left half, Spontaneously ovulated versus spontaneously ovulated treatment.

<sup>c</sup>Pink, top right half, Superovulated versus superovulated treatment.

Supplementary Table 3.4: Statistical Analysis<sup>a</sup> of *H19* Expression

	Superovulated <sup>c</sup>	In Vivo	Whittens	KSOMaa	Global	HTF	P1/MB	G1.5/G2.5
Spontaneous <sup>b</sup>								
In Vivo			0.00005	0.00005	0.0003	0.00014	0.0001	0.0008
Whittens		0.029		0.17	0.36	0.5	0.59	0.24
KSOMaa		0.002	0.65		0.36	0.5	0.59	0.24
Global		0.009	0.38	0.38		0.5	0.43	0.5
HTF		0.018	0.48	0.33	0.56		0.57	0.37
P1/MB		0.007	0.32	0.44	0.56	0.5		0.31
G1.5/G2.5		0.029	0.6	0.21	0.41	0.52	0.36	

<sup>a</sup>Fisher's exact test was used to compute the significance in number of embryos with and without *H19* expression between groups.  $P < 0.05$  was considered statistically significant.

<sup>b</sup>Purple, bottom left half, Spontaneously ovulated versus spontaneously ovulated treatment.

<sup>c</sup>Pink, top right half, Superovulated versus superovulated treatment.



Supplementary Table 3.6: Comparison of *H19* Expression and Imprinted Expression

Experimental Groups	Total	# Expressed	% Expressed <sup>a</sup>	# LOI	% LOI <sup>b</sup>
In Vivo	68	9	13	0	0
Spontaneous Ovulation /Culture	147	111	75	52	47
Superovulation/ Culture	120	113	94	82	73

<sup>a</sup>Percent expressed was calculated as # embryos with *H19* expression / total number of embryos analyzed.

<sup>b</sup>Percent LOI was calculated as # embryos with loss of *H19* imprinted expression / total number of embryos analyzed.

## Appendix 5: Copyright Releases

1. **Market-Velker, B.A.**, Zhang, L., Magri, L.S., Bonvissuto, A.C. & Mann, M.R. Dual effects of superovulation: loss of maternal and paternal imprinted methylation in a dose-dependent manner. *Hum Mol Genet* 19, 36-51 (2010).

License Number: 2656110158057

License date: Apr 25, 2011

Licensed content publisher: Oxford University Press

Licensed content publication: Human Molecular Genetics

Licensed content title: Dual effects of superovulation: loss of maternal and paternal imprinted methylation in a dose-dependent manner:

Licensed content author: Brenna A. Market-Velker, Liyue Zhang, Lauren S. Magri, Anne C. Bonvissuto, Mellissa R.W. Mann

Licensed content date: 01/01/2010

Type of Use: Thesis/Dissertation

Institution name: The University of Western Ontario

Title of your work: The Effects of Superovulation and Embryo Culture on Genomic Imprinting in a Mouse Model System

Publisher of your work: n/a

Expected publication date: Jun 2011

Permissions cost: 0.00 USD

Value added tax: 0.00 USD

Total: 0.00 USD

2. **Market-Velker, B. A.**, Fernandes, A. D. and Mann, M. R. Side-by-side comparison of five commercial media systems in a mouse model: sub-optimal *in vitro* culture interferes with imprint maintenance. *Biol Reprod* 83(6): 938-50 (2010)

Order detail ID: 53721716

ISSN: 1529-7268

Publication year: 2011

Publication Type: e-Journal

Publisher: SOCIETY FOR THE STUDY OF REPRODUCTION [ETC.]

Rightsholder: SOCIETY FOR THE STUDY OF REPRODUCTION

Author/Editor: Brenna Market-Velker

Your reference: Thesis - Chapter 2

Permission type: Republish or display content

Type of use: Republish in a dissertation

Republication title: The Effects of Superovulation and Embryo Culture on Genomic Imprinting

Republishing organization: The University of Western Ontario

Organization status: Non-profit 501(c)(3)

Republication date: 05/02/2011

Circulation/ Distribution: 6

Type of content: Full article/chapter

Description of requested content: Chapter 3: The Effects of Embryo Culture on  
Genomic Imprinting: Comparing 5 Commercially Available Media

Page range(s): 82-123

Translating to: No Translation

Requested content's publication date: 05/02/2011

Permission Status: Granted, \$ 3.50

---

**Brenna Ann Market Velker**  
**CURRICULUM VITAE**

---

**EDUCATION**

- MD/PhD Program, Biochemistry, The University of Western Ontario, London, Ontario, The Effects of Superovulation and Embryo Culture on Genomic Imprinting in a Mouse Model System, 07/2007 – Present, currently in Year 4.
- Honours Bachelors of Science, Biological Sciences with Thesis, The University of Windsor, Windsor, Ontario, The Role of SPDYA1 in Neurogenesis and Neuronal Malignancies, 2003– 2007.
- Ontario Secondary School Diploma (Bilingual), Honour Roll, Governor General's Award, Ecole Secondaire E. J. Lajeunesse, 1999-2003

**RESEARCH**

*Research-related Experience*

- MD/PhD Student, Dr. Mellissa Mann, Schulich School of Medicine and Dentistry, Department of Biochemistry, The University of Western Ontario, 2007-Present.
- Undergraduate Research Student, Dr. Mellissa Mann, 07/07-08/07.
- Honours Biology Student, Dr. Lisa Porter, University of Windsor, 2006-2007.
- Summer Research Student, Dr. Lisa Porter, University of Windsor, 2004-2007.
- Summer Research Student, Dr. Michael Crawford, University of Windsor, 2003.

*Awards*

- Canadian Institute of Health Research - Institute of Human Development, Child and Youth Health Summer Travel Award, 2009
- Honour Roll, The University of Western Ontario, 2007-Present.
- Wyeth Award for Excellence in Research, Department of Obstetrics & Gynaecology 1st place Graduate Student Oral Presentation, 2008
- Dean's Honour Roll, University of Windsor, 2004-2007.
- President's Roll, University of Windsor, 2003-2007.
- Canadian University Science Games, Team Windsor, 1<sup>st</sup> Place, 2006.
- Carter Bursary (Academic Excellence), 2003.
- Governor General's Academic Medal, EJ Lajeunesse, 2003.

*Scholarships*

- Hargreaves Endowment Scholarship, Schulich School of Medicine and Dentistry, 2009-2013.
- Schulich Research Opportunities Program (SROP), 2010

- NSERC Postgraduate Scholarship - Doctoral renewal / upgrade of CGS-M, 2008-2009.
- NSERC Canada Graduate Scholarship - Master's, 2007-2008.
- In-course Scholarship, University of Windsor, 2006.
- NSERC Undergraduate Student Research Award, 2006.
- NSERC Undergraduate Student Research Award, 2005.
- NSERC Undergraduate Student Research Award, 2004.
- Bill Eansor Award, 2003-2007.
- University of Windsor Renewable Entrance Scholarship, 2003-2007.
- Queen Elizabeth II Aiming for the Top Scholarship, 2003-2007.
- University of Windsor Community Scholars' Award, 2003.

### ***Peer-Reviewed Publications***

1. **Market Velker, B. A.**, Denomme, M. M., Mann, M. R., Loss of Genomic Imprinting in Embryos with Rapid Rates of Preimplantation Development. Submitted to *Developmental Biology* April 2011 Manuscript # DBIO-11-220
2. Lubanska, D., **Market, B.**, and Porter, L.A., The Novel Cell Cycle Mediator Spy1 Regulates Neurogenesis and is Implicated in Glioblastoma. Submitted to Cell Stem Cell, CELL-STEM-CELL-D-10-00107.
3. **Market-Velker, B. A.**, Fernandes, A. D. and Mann, M. R. Side-by-side comparison of five commercial media systems in a mouse model: suboptimal in vitro culture interferes with imprint maintenance. *Biol Reprod* 83(6): 938-50 (2010)
4. **Market-Velker, B.A.**, Zhang, L., Magri, L.S., Bonvissuto, A.C. & Mann, M.R. Dual effects of superovulation: loss of maternal and paternal imprinted methylation in a dose-dependent manner. *Hum Mol Genet* 19, 36-51 (2010)
5. Al Sorkhy M, Craig R, **Market B**, Ard R, Porter LA. The cyclin-dependent kinase activator, SPY1A, is targeted for degradation by the ubiquitin ligase NEDD4. *J Biol Chem*. 2009 Jan 30;284(5):2617-27. Epub 2008 Dec 3.

### ***Book Chapters***

1. **Market Velker, B. A.**, Denomme, M. M., Mann, M. R. Embryo Culture: Advances, Controversies, and Future Considerations, Chapter 23: Embryo Culture and Epigenetics. Humana Press. Swain, J.E., Pool, T., Smith, G. 2011

### ***Published Abstracts***

1. **Market BA**, Zhang L, Magri LS, Golding MC, Mann MR. Investigating the Molecular and Developmental Effects of Various Culture Regimes in a Mouse Model System, *Clinical Investigative Medicine* Volume 31, No. 4S April 2008.

### ***Conference Presentations***

1. **Market-Velker, B.A.**, Denomme, M.M., and Mann, M.R., Loss of Genomic Imprinting in Embryos with Rapid Rates of Preimplantation Development.

- Epigenetics, Eh! Canadian Conference on Epigenetics, London, Ontario, May 4<sup>th</sup>-7<sup>th</sup>, 2011, Poster.
2. **Market-Velker, B.A.**, Denomme, M. M., and Mann, M.R., Loss of Genomic Imprinting in Embryos with Rapid Rates of Preimplantation Development. Department of Obstetrics and Gynaecology Paul Harding Research Day, London, Ontario, April 27<sup>th</sup>, 2011, Poster.
  3. Lubanska, D., **Market-Velker, B.A.**, and Porter, L.A.,. A novel cell cycle regulator Spy1 is involved in Neurogenesis and Brain Cancer. Banff Signaling Meeting. March 2011.
  4. **Market-Velker, B.A.** and Mann, M.R., A side-by-side comparison of five commercial embryo culture media; effects on genomic imprinting. Department of Obstetrics and Gynaecology Paul Harding Research Day, London, Ontario, May 19<sup>th</sup>, 2010, Oral Presentation.
  5. **Market-Velker B.A.**, Zhang L., Magri L.S., Bonvissuto A.C., and Mann M.R., Dual Effects of Superovulation: Loss of maternal and paternal imprinted methylation in a dose-dependent manner, Gordon Research Conference: Mammalian Gametogenesis and Embryogenesis, Waterville Valley, New Hampshire, August 2-7, 2009, Poster.
  6. **Market-Velker B.A.**, Zhang L., Magri L.S., Bonvissuto A.C., and Mann M.R., Dual Effects of Superovulation: Loss of maternal and paternal imprinted methylation in a dose-dependent manner, Gordon Research Conference: Epigenetics, Holderness, New Hampshire, August 9-14, 2009, Poster.
  7. **Market-Velker BA**, Zhang L, Magri LS, Bonvissuto AC, and Mann MR, Investigating the molecular effects of superovulation and embryo culture on genomic imprinting in a mouse model system, 42<sup>nd</sup> Annual Society for the Study of Reproduction Meeting, Pittsburgh, PA, July 18-22, 2009, Poster.
  8. Al Sorkhy M., Craig, R., Ard, R., **Market, B.**, and Porter, L.A.,. The CDK activator, Spy1, is Targeted for Degradation by the Ubiquitin Ligase Nedd4 . Gordon Cell Growth and Proliferation Conference. Maine, July 2009.
  9. **Market-Velker BA**, Zhang L, Magri LS, Bonvissuto AC, Mann MR. Investigating the Molecular Effects of Assisted Reproductive Technologies on Genomic Imprinting in a Mouse Model System, Department of Obstetrics and Gynaecology Paul Harding Research Day, London, Ontario, May 13<sup>th</sup>, 2009, Oral Presentation.
  10. Lubanska, D., **Market, B.**, and Porter, L.A., Role of Spy1 in Neurogenesis; Potential Implications in Glioma Development. Apr. 2009 Southern Ontario Neuroconference Meeting. Hamilton, ON.
  11. **Market-Velker BA**, Zhang L, Magri LS, Bonvissuto AC, Mann MR, Effects of Assisted Reproductive Technologies on Genomic Imprinting, 2009 Great Lakes Developmental Biology Conference, The University of Toronto, Toronto, Ontario, March 6<sup>th</sup>, 2009, Oral Presentation.
  12. **Market-Velker BA**, Zhang L, Magri LS, Golding MC, Mann MR. Investigating the Molecular and Developmental Effects of Various Culture Regimes in a Mouse Model System, The Canadian Society for Clinical Investigation Young Investigator's Forum, MaRS Centre, Toronto, Ontario, September 25<sup>th</sup>, 2008, Oral Presentation.

13. **Market B.A.**, Zhang L., Magri L.S., Golding M.C., Mann M.R., Investigating the Molecular and Developmental Effects of Various Culture Regimes in a Mouse Model System, Department of Obstetrics and Gynaecology Paul Harding Research Day, London, Ontario, May 14th, 2008, 1<sup>st</sup> Place Graduate Student Oral Presentation.
14. Lubanska, D., **Market, B.**, Chen, L., and Porter, L.A., Role of Spy1 in Neurogenesis; Potential Implications in Glioma Development. Apr. 2008 Southern Ontario Neuroconference Meeting. London, ON.
15. Al Sorkhy M., Craig, R., **Market, B.**, Ard, R., and Porter, L.A., The CDK Activator, Spy1A, is Targeted for Degradation by the Ubiquitin Ligase Nedd4. Mar. 2008 IRCM Signaling Meeting. Banff, Alberta.
16. **Market B.**, Chen L, Porter LA. Implications of SPY1 in Neurogenesis and Brain Cancer, Ontario Biology Day, McMaster University, Hamilton, Ontario, March 18th, 2007, Poster Presentation.

## TEACHING

### *Mentorship*

- Rachael Pettapiece-Phillips, 4<sup>th</sup> Year Thesis Student, University of Western Ontario, 09/09-04/10
- Malaika Miles, Co-op High School Student and Summer Student, 03/09-08/09.
- Fatima Ba'abbad, Co-op High School Student and Summer Student, 02/08-08/08.
- Lauren Magri, McMaster University Co-op Student, 05/07-12/07.

### *Teaching Assistantships*

- Proctor, Department of Biochemistry, The University of Western Ontario, 2007-2009.
- Teaching Assistant, University of Windsor, Immunology, 2007.
- Teaching Assistant, University of Windsor, Biotechnology Laboratory, 2007.
- Teaching Assistant, University of Windsor, Genetics, 2006.
- Teaching Assistant, University of Windsor, Introductory Molecular Biology, 2006.
- Teaching Assistant, University of Windsor, Cell Biology, 2005.

## SERVICE

### *Committees*

- Vice President, Meds 2013 Class Council, Schulich School of Medicine, 2010-Present.
- Director, Meds 2013 Class Charity Committee, Rotholme Women and Family Shelter, 2010-Present.
- Meds 2013 Musculoskeletal System Block Student Representative, 2009.
- CIHR Trainee Excellence Committee, 2009.
- Meds 2013 Tachycardia Committee, 2009.
- Department of Biology Council, 4<sup>th</sup> Year Representative, University of Windsor, 2006-2007.
- Advisor, University of Windsor Undergraduate Biology Society, 2006-2007.

- President/Founder, University of Windsor Undergraduate Biology Society, 2005-2006.
- Member of University of Windsor Chemistry and Biochemistry Association, 2005-2006.
- Student Council Prime Minister, EJ Lajeunesse, 2002-2003.

***Professional Associations***

- Ontario Medical Association, 2009-Present.
- Canadian Medical Association, 2009-Present.
- American Society of Human Genetics, 2009-Present.
- Society for the Study of Reproduction, 2008-Present.

***Outreach***

- University of Western Ontario Pre-Med Symposium, 2011.
- Change Bandits, Children's Health Research Institute, 2007-2010
- Schulich School of Medicine Sun Safety Program, 2010.
- Volunteer, Windsor Regional Cancer Center, 2006-2007.
- Coach, Holy Name of Jesus Elementary School Senior Girl's Volleyball, 2004/2006.
- Tour Guide, Experience UWindsor, 2006.
- Volunteer, Knight of Columbus Hockey Skills Competition, 2005-2006.
- Coordinator, Mr. Kersey's Karate School Karate Sleepover for children 4-12yrs, 2005.
- Coordinator, Windsor Welcome Week and Head Start, 2004-2005
- Volunteer, Shinerama, 2004-2005.