



Title	Energy-aware dynamic route management for THAWS
Author(s)	Shen, Chong; Harte, Seán; Popovici, Emanuel M.; O'Flynn, Brendan; Barton, John
Editor(s)	Hailes, Stephen Sicari, Sabrina Roussos, George
Publication date	2009-09-09
Original citation	SHEN, C., HARTE, S., POPOVICI, E., O'FLYNN, B. & BARTON, J. 2010. Energy-aware Dynamic Route Management for THAWS. In: HAILES, S., SICARI, S. & ROUSSOS, G., eds. First ICST Conference on Sensor System and Software(S-Cubed), September 7-8, 2009 2010 Pisa, Italy. Berlin; Heidelberg; New York: Springer, 174-288.
Type of publication	Conference item
Link to publisher's version	http://www.springerlink.com/content/t72p83p5214117m1/ http://dx.doi.org/10.1007/978-3-642-11528-8_13 Access to the full text of the published version may require a subscription.
Rights	©ICST, The Institute for Computer Sciences, Social-Informatics and Telecommunications Engineering 2010
Item downloaded from	http://hdl.handle.net/10468/350

Downloaded on 2017-02-12T04:55:02Z



UCC

Coláiste na hOllscoile Corcaigh, Éire
University College Cork, Ireland



Cork Open Research Archive
Cartlann Taighde Oscailte Chorcaí

SHEN, C., HARTE, S., POPOVICI, E., O'FLYNN, B. & BARTON, J. 2010. Energy-aware Dynamic Route Management for THAWS. *In*: HAILES, S., SICARI, S. & ROUSSOS, G., eds. First ICST Conference on Sensor System and Software(S-Cubed), September 7-8, 2009 2010 Pisa, Italy. Berlin; Heidelberg; New York: Springer, 174-288. doi: 10.1007/978-3-642-11528-8_13

<http://www.springerlink.com/content/t72p83p5214117m1/>

The original publication is available at www.springerlink.com

CORA Cork Open Research Archive <http://cora.ucc.ie>

Energy-aware Dynamic Route Management for THAWS

Chong Shen, Sean Harte, Emanuel Popovici, Brendan O’Flynn, and John Barton

CLARITY Centre, Tyndall National Institute, Lee Maltings, Cork, Ireland
chong.shen@tyndall.ie,
WWW home page: <http://www.tyndall.ie/mai/>

Abstract. In this research we focus on the Tyndall 25mm and 10mm nodes energy-aware topology management to extend sensor network lifespan and optimise node power consumption. The two tiered Tyndall Heterogeneous Automated Wireless Sensors (THAWS) tool is used to quickly create and configure application-specific sensor networks. To this end, we propose to implement a distributed route discovery algorithm and a practical energy-aware reaction model on the 25mm nodes. Triggered by the energy-warning events, the miniaturised Tyndall 10mm data collector nodes adaptively and periodically change their association to 25mm base station nodes, while 25mm nodes also change the inter-connections between themselves, which results in reconfiguration of the 25mm nodes tier topology. The distributed routing protocol uses combined weight functions to balance the sensor network traffic. A system level simulation is used to quantify the benefit of the route management framework when compared to other state of the art approaches in terms of the system power-saving.

Key words: THAWS, Energy-aware, Routing, Energy model, Sensor network

1 Introduction

The Tyndall Heterogeneous Automated Wireless Sensors (THAWS) tool has two types of nodes with different functions selected from a number of different node layers developed by Tyndall Nation Institute [1]. Two modular nodes have been designed with a size of 10 mm by 10 mm, and 25 mm by 25 mm [2]. These are referred to as the 10mm and 25mm nodes shown in Figure 1. Each node has a processing and transceiver layer. Sensor layers can then be connected with application specific sensors. In addition to sensors, a battery or energy harvesting device can be connected to provide a power supply and each node can also provide its own energy level reading.

The 25mm node has more powerful processing capabilities than the 10mm node. This is provided by a layer with an Atmel ATmega128 microcontroller with 128 kB of program memory. There is also an FPGA layer and a number of different layers for RF communications. In the 2.45 GHz frequency band there

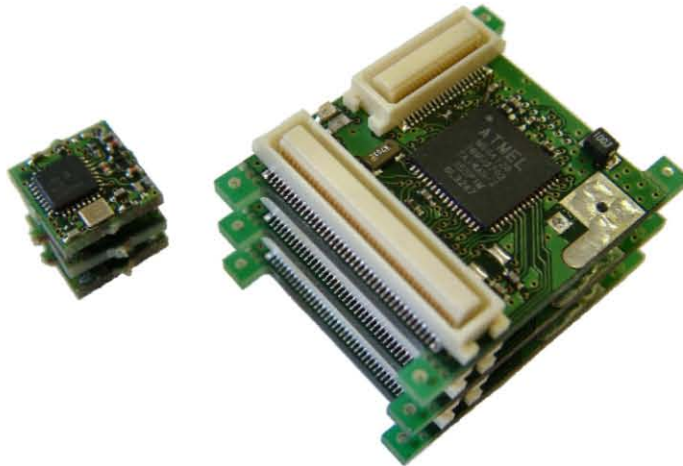

Fig. 1. 10mm (left) and 25mm (right) modular Tyndall nodes.

is a layer using a Nordic nRF2401 transceiver and another layer using an Ember EM2420 ZigBee 802.15.4 compatible transceiver. There is also a 433/868/915 MHz layer using a Nordic nRF905 transceiver, which allows a longer range, of up to 3.8 km in line-of-sight conditions, compared to the 2.45 GHz options, which have a maximum range of about 200 m [1]. The drawback is that bandwidth is limited to 50 kbps, compared to 1000 kbps for the Nordic nRF2401. The tradeoff between data rate and bandwidth is that a small bandwidth requires the radio transmit for a longer time, which consumes more energy. The 10mm node is currently a single transceiver layer, which uses a Nordic nRF9E5 chip. The chip has a radio that is compatible with the Nordic nRF905 so this allows heterogeneous networks to be built. This chip also has an integrated 8051-compatible microcontroller with a limited 4kB program memory. However, the 4KB memory is more than enough to be programmed to read and transmit sensor data, and handle 25mm association and deassociation in the THAWS. Meanwhile, the small size of the 10mm nodes allows a greater range of application with cheaper cost due to reduced PCB size, the lower component count, and cheaper assembly costs. The range of the 10mm node is less as the antenna does not perform well with such a small ground reference, and also less than optimal design of the balun circuitry in order to fit it into such a small area [2].

The core of the THAWS is an application generating tool, which has two main parts. The first of these is a software library containing modules of code that act as primitives in building up a WSN application. The second part is a description of the desired application. The second step of developing the THAWS tool is to propose energy-aware adaptive communication protocol considering self-organised medium access and energy-oriented dynamic routing path discovery as the key enablers. In this paper we propose a distributed route management protocol and an efficient energy model specifically for the THAWS tool, where the 25mm nodes are exclusively used as the base station nodes creating the first

network tier, and the 10mm nodes are used as the normal data collectors creating the second tier. Figure 2 presents an example THAWS tool topology with two tiers. Each 10mm node is associated with a 25mm node. It only has part of the 25mm communication functionalities. The 10mm only transmits collected data to its serving(associated) 25mm node base station. Complicated tasks such as data dissemination, topology control, fault recovery, internet gateway connection, etc. can be solely carried out at the 25mm nodes tier with more computation power when compared to the 10mm nodes tier. In the rest of the paper, we first review the state of art energy-aware routing protocols for the heterogeneous wireless sensor networks in Section 2. An energy model and a distributed network layer routing protocol will be detailed in Section 3. Section 4 provides the simulation models and protocols performance result with discussion. And finally in Section 5, a conclusion will be made with future research outlook.

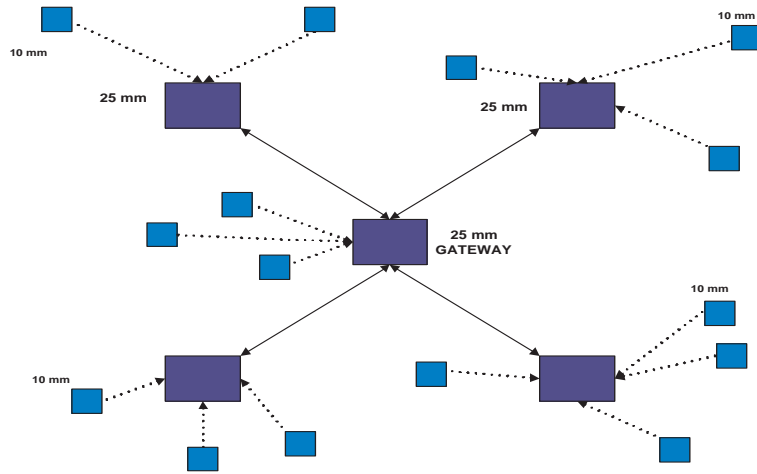

Fig. 2. Two-tiered heterogeneous network. The 25mm Tyndall nodes compose the first tier and some of them serve as gateway. The 10mm Tyndall nodes compose the second tier.

2 Related Work

Current research is making an effort to improve the heterogeneous wireless sensor network overall lifetime at the network layer. The sensor networks can be classified as one type of ad hoc networks but the ad hoc routing protocols e.g. Ad hoc On-Demand Vector (AODV) and Direct Source Routing (DSR) [6] can not be imported directly due to problems such as power constraints, limited microcontroller computation capability, different radio access methods, Radio Frequency (RF) modules, etc. In order to find a path from the source node to the destination node, usually, flooding is a classical way to propagate and disseminate data

but it always results in the broadcast storm problem, high message exchange overhead and fast node power consumption, which are unacceptable in wireless sensor networks.

Different proposals provided solutions for those problems mentioned above. Gossiping [3] is a probabilistic based flooding scheme, which tries to overcome the broadcast storm problem locally but at the cost of reliability. The use of gossiping method for unstable sensor networks routing may increase the overall or partial system failure rate. Sensor Protocol for information via negotiation (SPIN) [4] is a flat data centric routing technique based on exchange of meta-data before actual transmission. The meta-data exchange via data advertisements has proven to be very useful in overcoming the broadcast storm problem including redundancy, overlapping, and resource blindness. However, SPIN does not guarantee information delivery if intermediate nodes between the source node and destination node are not interested in the data advertisements. This disaccord the objective of Tyndall 25mm nodes tier guaranteed Quality of Service (QoS) data delivery. Directed Diffusion [5] is an important paradigm for the event monitoring of sensor networks. It uses attribute value pair for naming the data and queries the nodes or sensors in an on demand fashion by using the naming scheme and has achieved many fold energy efficiency as compared to classical flooding techniques but its emphasis on life time of an overall system is less. The THAWS tool prefers system-wide power saving rather than reduced individual node power consumption. On the other hand, The gradient set up phase is also expensive in terms of latency and energy consumption. Moreover, being a query driven data model, directed diffusion is not very efficient in applications where data is sent to the sink on continuous basis while the THAWS tool requires the 10mm tier continuously sends data to the 25mm tier.

For the AODV and DSR as mentioned previously, nodes periodically transmit routing table updates and generate networking traffic. As network size grows, the size of the routing tables and the bandwidth required to update them grows. The AODV is a reactive routing protocol, which uses sequence numbers of the destination that results in loop free topologies. Routes are acquired on demand, which results in extra delay known as route acquisition delay. Moreover, a large volume of message overhead is incurred if the routing information is changed when nodes are moved, but the power-aware THAWS tool constantly copes with the situations e. g. 25mm node failure or medium access slot failure. The DSR is very similar to the AODV, which is based on source routing where the source specifies the complete path to be taken by a packet. The Energy Aware Routing (EAR) [7] argues that using the minimum energy path all the time depletes the node energy on this path and result in a disconnected network topology. It instead uses a probabilistic approach in selecting the path to the destination by keeping more than one path toward the destination. The problem associated with the probability can be magnified when the THAWS scales to a large number of nodes. First of all, the multiple routing path storage requires sensor memory, which is not adaptive and consumes a lot sensor power. Secondly, we can not treat the 25mm and 10mm equally and nevertheless, it is impractical to have

a big routing table at each 10mm Tyndall node. There are few other complex routing protocols available such as gradient based routing, rumor routing, which are also not adaptive for a sensor system with ultra low power design objective.

3 Energy-aware Route Management for THAWS

With the aim to provide energy-aware and energy-efficient sensor network applications through the THAWS tool, we at the Tyndall National Institute (TNI) first identify and investigate a fixed heterogeneous sensor network infrastructure where all the positions of 25mm nodes and 10mm nodes are fixed thus the node mobility issues are not considered. The infrastructure, as a IEEE 802.15.4 compatible sub-network along with other different sub-networks at the Dublin City University (DCU), will be eventually connected to the University College Dublin (UCD) Internet database via IEFT IPv6 over Low power wireless Personal Area Networks (6LowPan) technology within the Science Foundation Ireland funded CLARITY [9] project. Figure 3 presents the cooperation plan between different institutes at different locations.

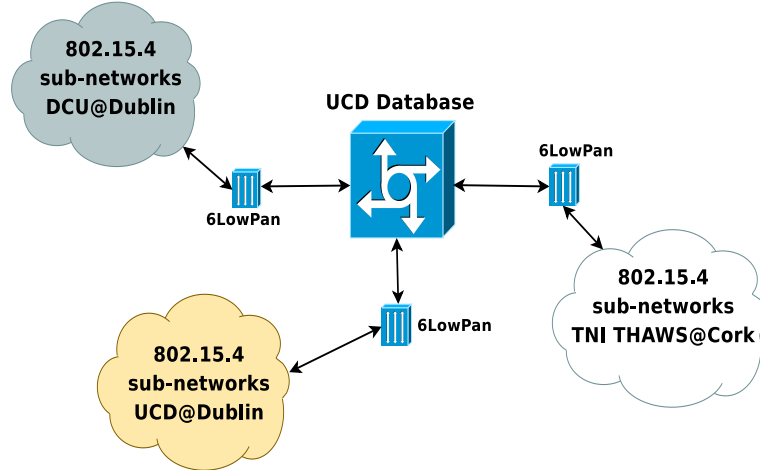

Fig. 3. The CLARITY project 6LowPan and IEEE 802.15.4 based system.

As specified in previous description for the 25mm nodes and 10 nodes at Section 1, due to the hardware limitation for the miniaturised 10mm node, it doesn't support 802.15.4 using Nordic radio microcontroller. Therefore, the 6LowPan gateway connections and distributed route management functions for the THAWS tool have to be handled at the 25mm nodes.

3.1 Node Energy Model

The goal of the use of an energy model control is to periodically monitor 25mm base station nodes energy consumption status in order to maintain some property of the communication graph, while dynamically change the number of 10mm nodes association as the energy consumed by the communications between the serving 25mm node and its associated 10mm nodes is one of the primary sources of energy consumption. The Tyndall 25mm node can also adaptively change the transmission range to achieve a good energy efficiency using different RF modules. The route management protocol considers the THAWS power efficiency as the primary optimisation objective, and packet transmission delay and packet successful delivery ratio as the secondary optimisation objectives. Therefore, a practical three states energy model is first proposed for the 25mm nodes.

The THAWS topology has been analysed as shown in Figure 4. Based on the energy mapping technology for both 25mm nodes and 10mm nodes, given energy levels of the nodes, the THAWS tool can roughly predict future state of the network. The spatial and temporal energy gradient of the network nodes may also be modelled. Coupled with network topology, this can be used to identify “weak areas” of the network. Most importantly, each 25mm node decides how many 10mm nodes it serves at first instance and exchanges information with other 25mm nodes to handover or accommodate 10mm nodes.

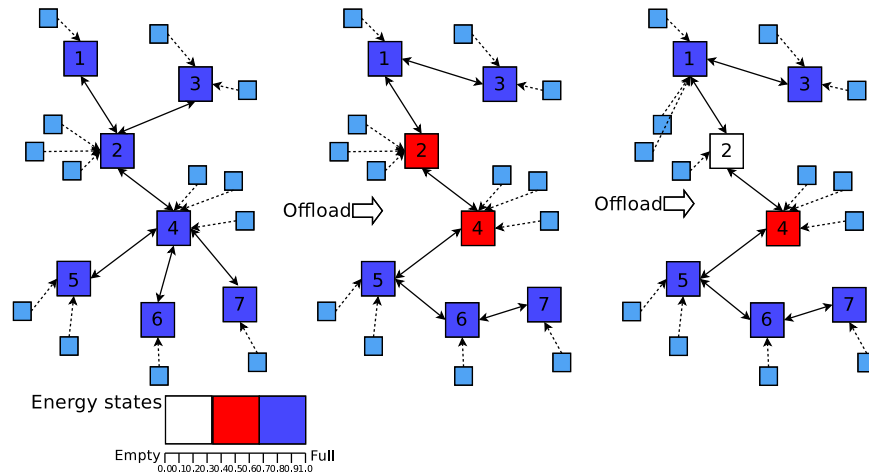

Fig. 4. The Tyndall 25mm nodes practical energy model based traffic offloading illustration.

The 25mm distributed energy-aware offloading mechanism includes two sub-algorithms in respect to the node energy states as presented in Figure 4. The energy-model at each 25mm node uses a linear energy function to describe the energy level:

$$E = 1 - T_a C_a - T_s C_s \quad (1)$$

Where 1 stands for full energy level. T_a and T_s are the Tyndall 25mm node usage time accumulated in the active mode and sleep mode, respectively. C_a and C_s are the 25mm typical energy used at the active mode and sleep mode. The 10mm node uses a similar energy-model and it shuts down when the energy is empty. Two hard boundaries, which are 0.33 and 0.67, have been introduced to trigger the two sub-protocol named Level 1 Offloading (L1O) and Level 2 Offloading (L2O). The three energy states are Full $E = (0.67, 1]$, Normal $E = (0.33, 0.67]$ and Restricted $E = (0, 0.33]$. The reason to only have two sub-protocols with two hard boundaries is the energy saving consideration because the frequent network topology and unnecessary information exchange must be avoided.

As shown in Figure 4, the example network (cluster) consists of 7 first tier 25mm nodes and a number of second tier 10mm nodes connected to the 25mm nodes. When 25mm node 2 and node 4 change the energy state to Normal (red coloured) state, the L1O protocol is triggered:

L1O A 25mm node searches other first tier 25mm nodes using Routing Request (RREQ) message to reduce the number of intra-tier connections, which result in the node energy saving since the time spent on active transmission mode will be reduced. In order to retain the connectivity of the entire network, a spanning tree [10] algorithm is used. To avoid flooding information through the entire 25mm node tier, it is divided into several clusters and each cluster includes a number of 25mm nodes e.g. 7 nodes. Therefore in a sensor node mapped graph (a cluster) there is a subgraph which is a tree and connects all the vertices together. A single graph can have many different spanning trees. We assign a energy model based weight function to each edge, which is a number representing how unfavorable it is, and use this to assign a weight to a spanning tree by computing the sum of the weights of the edges in that spanning tree. We also assign a higher energy weight upon the links associated with state change. A minimum weight spanning tree is then a spanning tree with a weight less than or equal to the weight of every other spanning tree.

Using the L1O protocol, the connection within the seven 25mm nodes cluster has been changed after node energy based weight calculation at each link. Node 1 connects to node 3 and node 3 disconnects from node 2. Node 2 disconnects from node 3. Node 4 disconnects from both node 6 and node 7. Node 5 connects to node 6. Node 6 connects to node 5 and disconnects from node 4. Node 7 connects to node 6 which has a higher energy left and disconnects from node 4.

When 25mm node 2 changes the energy state from Normal state to Restricted (write coloured) state, the L2O protocol is triggered:

L2O A 25mm node searches other first tier 25mm nodes using Routing Request (RREQ) message to reduce the number of inter-tier connections and shift a number of its associated 10mm nodes to its neighbouring 25mm nodes, after

acknowledged answer from the neighbouring 25mm nodes through Routing Reply (RREP). The neighbouring nodes will not reply RREP to the requesting 25mm node unless two conditions are satisfied, which are the transmission range of a candidate 10mm node & available medium access slots.

Using the L2O protocol, as indicated in 4, 25mm node 2 with restricted energy state disconnects two of its associated 10mm nodes. The two 10mm node are then connects to 25mm node 1. The other 10mm node can not be connected to node 1 due to the transmission range problem.

3.2 Energy-aware Power Saving Protocol

The Energy-aware power saving protocol for the THAWS operates distributedly. It comprehensively considers three parameters: Energy Consumption (E), Packet Delivery Delay (D) and Packet Successful Delivery Ratio (S) to the distributed protocol. The shortest path between the source node to the sink node (or say hop distance) is usually a critical parameter for a dynamic environment, but for the nodes position fixed THAWS it is not necessary. A function is assigned to each 25mm node and the routing path between the source 25mm node and the destination 25mm node is based on the calculation of a function:

$$F_n = \alpha E_n + \beta D_n + \gamma S_n \quad (2)$$

Where n is the node number or an identifier assigned to a 25mm node. Each parameter has been given a weight factor, which are α for energy consumption), β for packet Delivery Delay and γ for packet successful delivery ratio depending on different wireless sensor network application requirement, and the add sum of $\alpha + \beta + \gamma = 1$. A localised flooding technique is used to find next hop neighbouring 25mm node distributedly and system-wide probing message flooding is prohibited to reduce data exchange overhead. For example, if an application requires a guaranteed packet delivery with a time restriction, we can assign a higher weight factor value to β and γ while reducing the value of α . Instead of reacting to the environmental change (power level) in a reactive manner as in the proposed energy model based L1O & L2O, the protocol operates proactively to balance traffic within the THAWS. For example, as shown in Table 1 with 7 nodes scenario, we first assign 0.5, 0.25 and 0.25 to α , β and γ to prioritse an energy-efficient sensor network application. We also assume node 1 is the source node and node 7 is the destination node (sink) which connects to the 6LowPan based IP network.

The label routing concept and routing table style originated in ATM networks [11] and has been introduced to the protocol since the position of the 25mm node is fixed and the label based switching provides faster packet forwarding than IP based indexing or other mature reactive routing protocol such as AODV and DSR. Instead of finding the next relay node hop by hop, the path from the source node to the sink node is identified by multiple labels where the label is represented by the added value of two neighbouring nodes $L_{a,b} = F_a + F_b$. Then

Table 1. An example weighted function calculation for 7 nodes

	αE	βD	γS	F
Node1	0.50	0.25	0.25	1.00
Node2	0.48	0.25	0.25	0.98
Node3	0.37	0.24	0.24	0.85
Node4	0.46	0.25	0.25	0.96
Node5	0.42	0.24	0.24	0.90
Node6	0.39	0.25	0.25	0.89
Node7	0.50	0.25	0.25	1.00

the next actual node the source node is hopping to is decided by a comparison of the added value between next hopping neighbours as shown in Table 2. We can also understand that the path is separated by several labelled segments. The routing table at each 25mm node has seven message types: Label in, Label out, Source node, Destination node, Destination Sequence, Hop count and Time to live (TTL). The relay nodes only need to find the available entry indexed by label in the packet, swap it with respective label out of this entry, and then send it out to the next relay node.

Table 2. An example label based added value calculation for 7 nodes

	Node1	Node2	Node3	Node4	Node5	Node6	Node7
Node1	N/A	1.98	1.85	N/A	N/A	N/A	N/A
Node2	1.98	N/A	1.83	1.94	N/A	N/A	N/A
Node3	1.85	1.83	N/A	N/A	N/A	N/A	N/A
Node4	N/A	1.94	N/A	N/A	1.86	1.85	1.96
Node5	N/A	N/A	N/A	1.86	N/A	1.79	N/A
Node6	N/A	N/A	N/A	N/A	1.79	N/A	1.89
Node7	N/A	N/A	N/A	1.96	N/A	1.89	N/A

Figure 5 illustrates the label exchange over seven 25mm nodes scenario. After compare the added weight value function $L_{a,b}$, source node 1 checks the sequence number (SEQ) of the destination node 7 in the current path in order to avoid old path information. It should be at least as great as the value entry in the current request otherwise the existing path in the table will be discarded. Another function of the SEQ is to compare with its older value to increase the hop count, e.g. if the source node can not find the destination node, it will increment the hop count by one and then broadcast it to its neighbours. The hop distance is not necessarily considered due to the fixed infrastructure and eventually balanced traffic distribution. However, it is defined that the path keeps the hop count as small as possible to avoid abused path violation. Meanwhile, the label request will repeat once for each connection request. The second plot in Figure 5 presents the propagation mechanism and the label based routing path segmentation. The third plot presents that the routing path has been established

between the source Node 1, Node 2, Node 4, and the destination Node 7 after label message exchange and weight functions comparison.

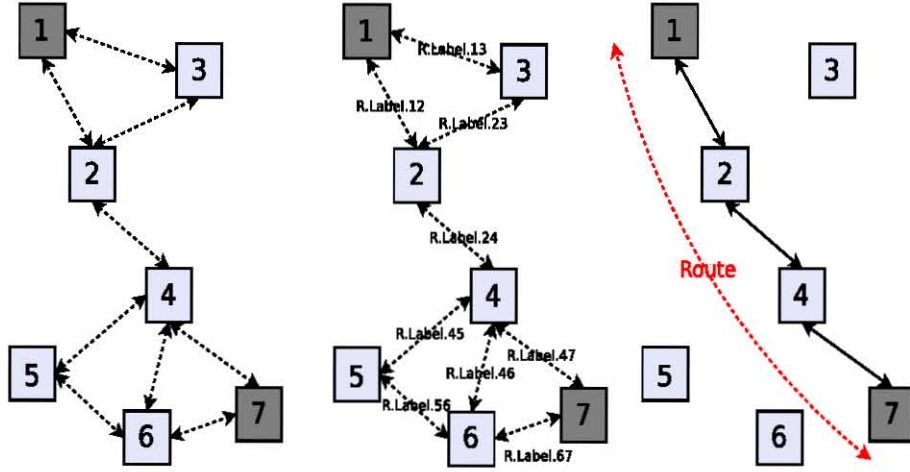

Fig. 5. The energy-aware power saving routing protocol illustration with fast label exchange.

4 Simulations

Before deploying C based code to both 10mm and 25mm Tyndall nodes, a discrete event simulation tool known as OMNeT++ [8] is used for the evaluations. The simulation provides facilities to model the communications between the nodes. It serves as a validation and optimisation tool for THAWS fast sensor network applications development and deployment.

In the experiment, 98 25mm nodes are modelled and placed in a 3000 m x 3000 m area and 196 10mm nodes are also randomly distributed. Each 10mm node is first associated with a 25mm node. For 25mm base station nodes, 7 of them are grouped as a cluster therefore 14 clusters are formed. The gateway (or say clusterhead for 6LowPan deployment) is randomly positioned at the cluster boundaries. At the beginning of the simulation, all 25mm nodes starts with full energy unit (1 Unit). With every reception, transmission and message exchange a 25mm node constantly decreases the energy at the active mode otherwise it is in the sleep mode. The 10mm node also starts with full energy unit. Node only periodically transmits data and then puts itself in sleep mode. Free space propagation model and Additive White Gaussian Noise (AWGN) environment are used. Each 25mm transmission range is set to 3 km while 10mm is set to 100 m. The network stack consists of physical layer, Address Resolution Protocol (ARP) module, modified 802.11 based slotted medium access module, link layer

and interface priority queue. The bandwidth is fixed at 2 Mbps for a higher bound optimisation. The data is transmitted at Constant Bit Rate (CBR) at payload of 512 bytes with different deadlines. Data packets are generated at the source at a rate of 0.5, 1.0, 1.5, 2.0, 2.5 and 3.0 packets/s.

We have compared the performance of our THAWS energy-aware label based routing management (THAWS-R) with EAR and a modified classic AODV (without mobility header packets) protocol. The energy-model with L1O and L2O mechanisms proposed is also used at each 25mm node.

4.1 System Lifetime

Figure 6 compares the system lifetime for different route management approaches as it is a critical objective for the THAWS-R to achieve. The system life time parameter is scaled from 0-100 according to the system power left at all Tyndall 25mm and 10mm nodes. We first define system failure as the time after which 33% of sensor nodes run out of batteries that resulting in a routing hole. In the result, the simplified AODV presents the worst performance as expected because the system wide flooding produces a large number of signalling exchange overhead. The sensor system consumes a large amount of power at 25mm base station nodes when active. It has been proved that the protocol is neither adaptive nor energy-efficient also due to the route change latency. On the other hand, as a linear energy model is used in each 25mm node, the rate of partial or system wide 25mm nodes power drainage is increased, which resulting in a shorter system lifetime. EAR gives a higher priority to energy-efficiency therefore it presents a better performance than AODV. However, it implements multicast instead of unicast, and does not consider a restricted neighbouring path finding mechanism with weight functions as compared to THAWS-R, both the 25mm and 10mm will have to spend more time at active mode. As evident by the graph, the THAWS-R management is the most energy-efficient protocol when compared to the other two. It is able to balance node energy utilisation system wide and also accounts for the delay critical to real-time applications by using label routing mechanism.

Figure 7 presents the average active mode rate of all 25mm and 10mm nodes after a simulated 70 hours run. All packets are transmitted at 2 packets/s. From the results we notice that the node active mode rates using simplified AODV increase rapidly after 30 hours run. The trend is approaching the maximum when the simulation is finishing. The 25 sensor node consumes a large amount of battery power to find a route to the sink node. After a long run, many sensor nodes even go down if the detected events are not arriving at the sink node or due to power drainage. The rest of the sensor nodes have to make effort on path finding repeatedly and data forwarding, which results in more sensor nodes works at active mode. EAR protocol without an adaptive localised routing functions, presents a slight better results than the simplified AODV. During the 70 hours run, the average rate that nodes at active mode is smooth. Less nodes go down due to issues such as power drainage and the traffic is reasonably distributed across the system. However, this probability based approach mainly considers power criteria but not the packet delivery rate, delivery delay and

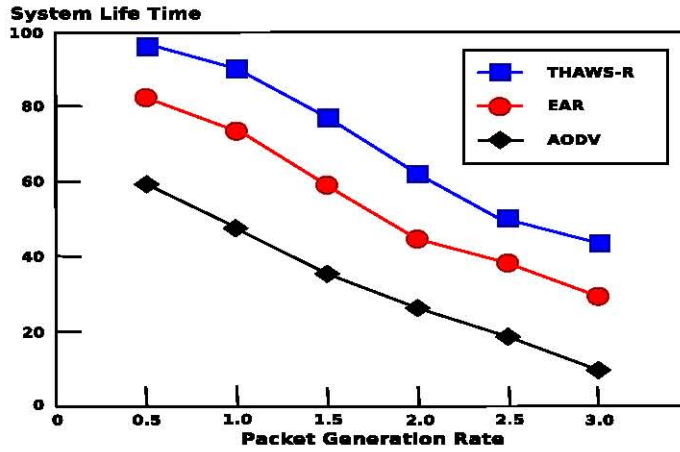

Fig. 6. System lifetime for different route management schemes and protocols.

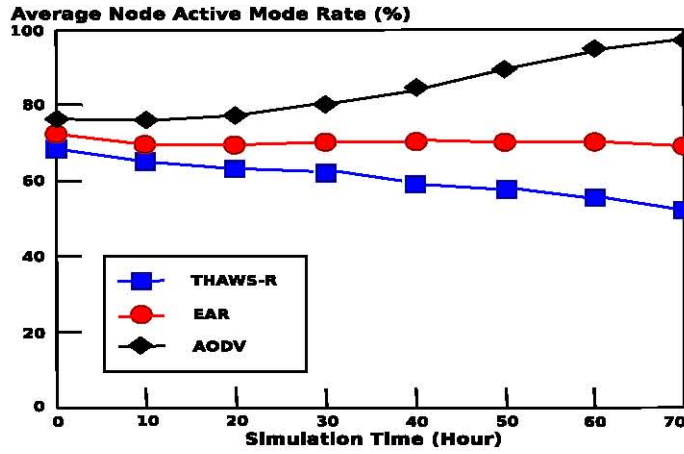

Fig. 7. Average nodes at active mode rate for different route management schemes and protocols.

link establishment speed. The proposed THAWS-R route management protocol, again, gives the best results against the other two. The active sensor node rate using distributed weight functions and label based route establishment even decreases with increasing simulation time. This is because the restricted flooding (local neighbour finding) and label routing help to construct adaptive routes to sink nodes across the system. The label indexing other than direct next hop indexing, greatly reduces the time that nodes spend on active mode.

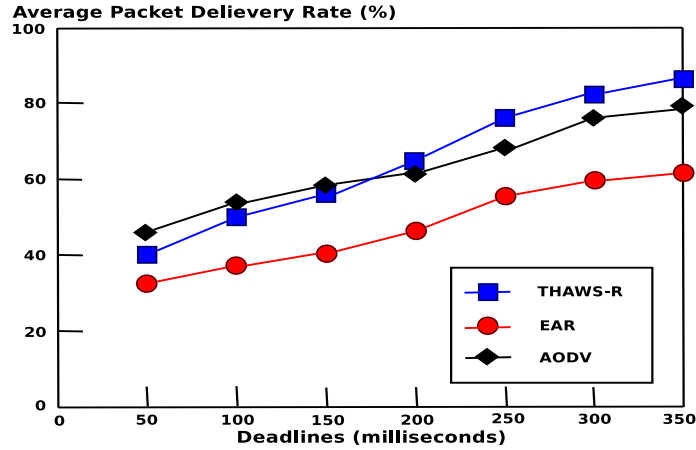

Fig. 8. Packet delivery ratio for different route management schemes and protocols.

4.2 Packet Delivery

For the packet level data delivery, it is important that traffic should reach the destination within the deadline, otherwise the data must be resent or recollected, which consumes nodes power. Our route management strategy is aware of packet delivery using the weighted Equation 2 thus low-rated routes (packet delivery error-prone paths) are avoided largely to make sure packets reaching the destination before the deadline proactively. AODV sends packet by different routes that increases the reliability. This is evident in Figure 8, where we have compared the packet delivery percentage with the deadlines. When the deadline is long enough, all three schemes achieve a satisfactory packet delivery percentage. When the deadlines are configured more and more aggressive, the results show the delivery percentage reduces drastically for EAR protocol. The proposed THAWS routing scheme has a slightly higher successful delivery ratio than AODV with aggressive deadlines (starting from 200 milliseconds) due to its adaptivity. However, as stated previously, the THAWS weight function based routing can enhance one performance metric while worsening another. Therefore choosing the routing approach is greatly influenced by the performance qualification metrics, which are highly dependent on the nature of sensor network applications. If data delivery loss rate is of great interest, and latency and energy conservation are of concern, one might pick a higher weight factor to further enhance the system packet delivery rate.

For the average packet delay evaluation, the THAWS route management, again, gives the best performance when compared to the other two schemes as indicated in Figure 9. This is expected as the delay function has been included in the protocol to find the next hop node, the traffic has been evenly distributed with reduced congestion and the fast label routing speeds up the route establishment process. Meanwhile, AODV gives the worst result as it tries to exhaustively flood the system with large number of hops. This makes packets visit multiple

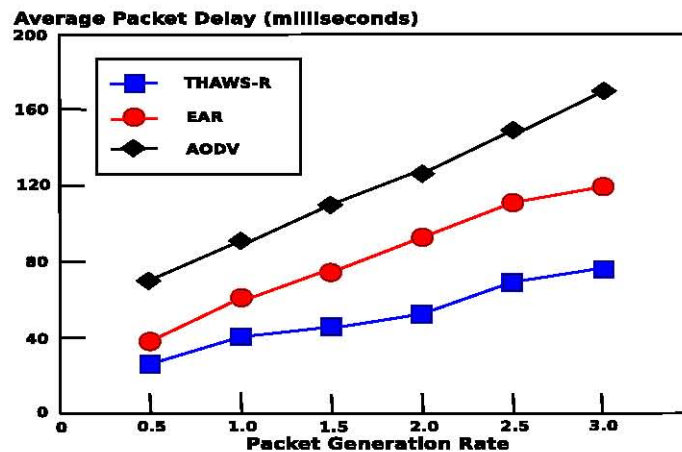

Fig. 9. Average packet delay for different route management schemes and protocols.

nodes incurring more transmission and queuing delay. EAR presents a slightly better result than AODV but it also tries to minimise the transmission power by taking shorter distance, is not aware of system wide power utilisation, and chooses the next hop node solely based on geographic information with energy mapping.

5 Conclusions

This paper has presented a practical route management framework specifically for the Tyndall heterogeneous automated wireless sensor tool. The analysis and simulation results confirm that the proposed protocol and the 25mm tier energy model based dynamic load balancing significantly improve the platform performance in terms of node energy consumption, packet delivery delay and packet successful delivery ratio. Moreover, the lifetime of the overall THAWS tool is considerably increased. Future work will look at the deployment issues for the 10mm nodes and 25mm nodes and Tyndall nodes based embedded system software development and hardware updates.

References

1. Harte, S., Popovici, E., O'Flynn, B., O'Mathuna, C.: THAWS: Automated Design and Deployment of Heterogeneous Wireless Sensor Networks. In WSEAS Trans. Circuits and Systems, Vol. 7, No. 9, pp. 829-838, (2008)
2. Harte, S., O'Flynn, B., Martinez-Catal, R., Popovici, E.: Design and Implementation of a Miniaturised, Low Power Wireless Sensor Node. In Proc. 18th Euro. Conf. Circuit Theory and Design, Seville, pp. 894-897, (2007)

3. Akyildiz, I., Su, W., Sankarasubramaniam, W., Cayirci, E.: Wireless Sensor Networks: a Survey. In *Computer Networks Elsevier Journal*, Vol. 38, No. 4, March (2002)
4. Heinzelman, W., Kulik, J., Balakrishnan, H.: Adaptive Protocols for Information Dissemination in wireless sensor networks. In *Proc. of IEEE MobiCom.*, Seattle, WA, August (1999)
5. Wattenhofer, R., Li, P., Wang, Y.: Distributed Topology Control for Power Efficient Operation in Multihop Wireless Ad Hoc Networks. In *Proc. of IEEE InfoCom*, April (2001)
6. Ganesan, D., Govindan, R., Shenker, S., Estrin, D.: Highly-Resilient, Energy-Efficient Multipath Routing in Wireless Sensor Networks. *Mobile Computing and Communications Review*, 1-2, (1997)
7. Shah, R., Rabaey, J.: Energy Aware Routing for Low Energy Ad Hoc Sensor Networks, In *Proc. of IEEE WCNC*, Orlando, FL, March (2002)
8. Varga, A.: Using the OMNeT++ Discrete Event Simulation System in Education. In *IEEE Trans, on Education*, Vol. 42, No. 4, (1999)
9. CLARITY: The Centre for Sensor Web Technologies Bringing Information to Life. <http://www.clarity-centre.com>
10. Chazelle, B., Rubinfeld, Trevisan, L. Approximating the Minimum Spanning Tree Weight in Sublinear Time, In *Computation Journal*, pp 1370-1379, 34 (2005)
11. Leon-Garia, A., and Widjaja, I. *Communications Networks*, McGraw Hill (1999)