

**PHS PUBLIC ACCESS**

Author manuscript

*Genes Brain Behav.* Author manuscript; available in PMC 2016 April 29.

Published in final edited form as:

*Genes Brain Behav.* 2015 January ; 14(1): 98–135. doi:10.1111/gbb.12189.**Preclinical evidence implicating corticotropin-releasing factor signaling in ethanol consumption and neuroadaptation****T. J. Phillips<sup>†,‡,\*</sup>, C. Reed<sup>‡</sup>, and R. Pastor<sup>‡,§,¶</sup>**<sup>†</sup>VA Portland Health Care System, Portland Alcohol Research Center, Methamphetamine Abuse Research Center, Oregon Health & Science University, Portland, OR, USA<sup>‡</sup>Department of Behavioral Neuroscience, Portland Alcohol Research Center, Methamphetamine Abuse Research Center, Oregon Health & Science University, Portland, OR, USA<sup>§</sup>Area de Psicobiología, Universitat Jaume I, 12071 Castellón, Spain<sup>¶</sup>Department of Psychology, Reed College, Portland, OR, USA**Abstract**

The results of many studies support the influence of the corticotropin-releasing factor (CRF) system on ethanol (EtOH) consumption and EtOH-induced neuroadaptations that are critical in the addiction process. This review summarizes the preclinical data in this area after first providing an overview of the components of the CRF system. This complex system involves hypothalamic and extra-hypothalamic mechanisms that play a role in the central and peripheral consequences of stressors, including EtOH and other drugs of abuse. In addition, several endogenous ligands and targets make up this system and show differences in their involvement in EtOH drinking and in the effects of chronic or repeated EtOH treatment. In general, genetic and pharmacological approaches paint a consistent picture of the importance of CRF signaling via type 1 CRF receptors (CRF<sub>1</sub>) in EtOH-induced neuroadaptations that result in higher levels of intake, encourage alcohol seeking during abstinence and alter EtOH sensitivity. Furthermore, genetic findings in rodents, non-human primates and humans have provided some evidence of associations of genetic polymorphisms in CRF-related genes with EtOH drinking, although additional data are needed. These results suggest that CRF<sub>1</sub> antagonists have potential as pharmacotherapeutics for alcohol use disorders. However, given the broad and important role of these receptors in adaptation to environmental and other challenges, full antagonist effects may be too profound and consideration should be given to treatments with modulatory effects.

**Keywords**

Alcohol; alcohol use disorder; ethanol drinking; ethanol seeking; genetic animal model; HPA axis; knockout; pharmacology; pharmacotherapy; sensitization; stress; urocortin

---

Interest in stress and stress-associated pathways for their roles in alcohol (ethanol, EtOH) use and related symptoms has a long history. The focus has evolved over time from

---

\*Corresponding author: T. J. Phillips, PhD, VA Portland Health Care System, Research Service, R&D32, 3710 SW US Veterans Hospital Road, Portland, OR 97239, USA. [phillipt@ohsu.edu](mailto:phillipt@ohsu.edu).

examination of behavioral effects of stressors on EtOH-associated traits and effects of EtOH on stress-axis measures, such as corticosterone (CORT) and adrenocorticotropin hormone (ACTH) levels, to investigation of the relevance of central and peripheral peptides and receptors. In the last decade, a number of excellent reviews have described much of this literature and have influenced the authors' perspectives (Allen *et al.* 2011; Armario 2010; Burke & Miczek 2014; Ciccocioppo *et al.* 2009; Clapp *et al.* 2008; Crabbe *et al.* 2006; Gilpin 2012; Griffin 2014; Heilig & Koob 2007; Heilig *et al.* 2010; Koob 2013; Leggio *et al.* 2010; Lowery & Thiele 2010; Lu & Richardson 2014; Martin-Fardon *et al.* 2010; Rivier 2014; Roberto *et al.* 2012; Ryabinin & Weitemier 2006; Ryabinin *et al.* 2012; Shalev *et al.* 2010; Silberman *et al.* 2009; Sommer & Saavedra 2008; Spanagel *et al.* 2014; Sprow & Thiele 2012; Thiele 2012; Weiss *et al.* 2001; Wong & Schumann 2012; Zorrilla *et al.* 2013, 2014). Because there is already an excellent, recent literature in this area, we do not comprehensively repeat this information in the current review. Rather, this article reviews the preclinical literature investigating the importance of the corticotropin-releasing factor (CRF) system specifically in EtOH consumption and neuroadaptation-related behaviors. We also include comments on pertinent human data and suggest future perspectives.

## The CRF System

Corticotropin-releasing factor has also been known as corticotropin-releasing hormone or CRH and is a 41-amino acid neuropeptide critically involved in the regulation of neuroendocrine and behavioral responses to stress. An intricate CRF-mediated system, involving hypothalamic and extra-hypothalamic mechanisms, regulates peripheral and central actions that allow for preparation and adaptation to environmental challenges or stressors (Bale & Vale 2004; de Kloet 2013; Hauger *et al.* 2006). The seminal work of Vale and colleagues identified CRF as the primary molecule responsible for the activation of this neuroendocrine stress cascade, the hypothalamic–pituitary–adrenal (HPA) axis (Bale & Chen 2012; Rivier & Vale 1983a,1983b; Rivier *et al.* 1982; Spiess *et al.* 1981; Swanson *et al.* 1983; Vale *et al.* 1981). Activation of the HPA axis is triggered by neurons of the medial dorsal parvocellular region of the paraventricular nucleus (PVN) of the hypothalamus (Armario 2006, 2010; Herman *et al.* 2003). This region is rich in CRF and other neuropeptides, such as vasopressin (arginine-vasopressin; AVP). Although the role of AVP in activating the HPA axis *per se* appears to be limited, AVP can significantly increase the effects of CRF (Rivier & Vale 1983a,1983b; Sawchenko *et al.* 1984; Vale *et al.* 1981, 1983).

Paraventricular nucleus neurons release CRF at the level of the median eminence, inducing (via the hypophyseal portal system) the release of ACTH by corticotrope cells of the anterior pituitary. In turn, ACTH activates the secretion of the glucocorticoid, CORT (cortisol in humans) from the zona fasciculata of the adrenal cortex. Corticosterone plays an important role in regulating a number of physiological functions and modulates CRF signaling via a hypothalamic negative feedback mechanism that decreases CRF-mediated HPA axis activation; CORT also regulates an extra-hypothalamic positive regulatory mechanism that increases CRF activity (Bale & Vale 2004; Shepard *et al.* 2006). In the mammalian brain, CRF is identified in the PVN, but high levels of CRF are also found outside of the hypothalamus in structures such as the central nucleus of the amygdala (CeA), bed nucleus of the stria terminalis (BNST), hippocampus, thalamus, midbrain and locus coeruleus

(Merchenthaler *et al.* 1982, 1984; Morin *et al.* 1999; Steckler & Holsboer 1999; Swanson *et al.* 1983). Glucocorticoid-induced increases in CRF activity have been particularly well characterized in the CeA and BNST (Shepard *et al.* 2006; Tran & Greenwood-Van Meerveld 2012). The extra-hypothalamic, neuroregulatory actions of CRF contribute to the integration of endocrine, sympathetic, behavioral and cognitive responses to stress, and are particularly involved in the emotional component of stress (Gilpin 2012; Hauger *et al.* 2006; Müller *et al.* 2003; Walker & Davis 2008; Walker *et al.* 2009). Although stressors initiate a series of CRF-mediated neuronal responses that can be beneficial and adaptive, dysregulation of CRF systems can be deleterious, and has been linked to a wide range of disorders including anxiety, depression, obsessive-compulsive disorder, post-traumatic stress disorder and addiction (Cador *et al.* 1993; Cole *et al.* 1990; Haass-Koffler & Bartlett 2012; Heilig & Egli 2006; Koob & Kreek 2007; Koob & Le Moal 2001; Sarnyai *et al.* 2001).

### CRF system endogenous ligands, binding targets and pathways

Figure 1 summarizes the endogenous ligands, targets and target distribution, and illustrates the affinity of each CRF family neuropeptide for each CRF-related binding target. CRF actions are exerted through two Gs-protein coupled receptors, CRF type-1 (CRF<sub>1</sub>) and type-2 (CRF<sub>2</sub>), which share about 70% amino acid sequence identity (Bale & Vale 2004; Hauger *et al.* 2006). Corticotropin-releasing factor shows greater affinity for CRF<sub>1</sub> (Herman *et al.* 2003; Vaughan *et al.* 1995) and CRF-initiated activation of the HPA axis is mediated by CRF<sub>1</sub> (Armario 2006; Bale & Vale 2004). Corticotropin-releasing factor type-1 expression is found in many brain regions (Justice *et al.* 2008; Korosi *et al.* 2006, 2007; Kühne *et al.* 2012; Van Pett *et al.* 2000). In the cortex and hippocampus, CRF<sub>1</sub> is present on glutamatergic neurons, whereas CRF<sub>1</sub> is found on  $\gamma$ -aminobutyric acid (GABA) neurons in the striatum (including the nucleus accumbens; NAcc) and dopamine (DA) neurons in the midbrain (including the ventral tegmental area; VTA) (Bonfiglio *et al.* 2011; Lemos *et al.* 2012; Refojo *et al.* 2011). Corticotropin-releasing factor type-2 is also widely expressed in the central nervous system and found peripherally (Bittencourt & Sawchenko 2000; Korosi *et al.* 2006, 2007; Lukkes *et al.* 2011; Palchadhuri *et al.* 1999; Van Pett *et al.* 2000). Although there is significant overlap in brain distribution of CRF<sub>1</sub> and CRF<sub>2</sub> (Hauger *et al.* 2006; Lukkes *et al.* 2011), important differences in distribution have also been found. For example, CRF<sub>2</sub>, but not CRF<sub>1</sub>, is present in the ventromedial and medial preoptic nuclei of the hypothalamus; CRF<sub>1</sub>, but not CRF<sub>2</sub>, is expressed in the NAcc and the CeA; and both CRF<sub>1</sub> and CRF<sub>2</sub> are present in the medial nucleus of the amygdala (Bittencourt & Sawchenko 2000; Hauger *et al.* 2006; Van Pett *et al.* 2000). A primary CRF<sub>2</sub>-mediated regulation of serotonergic neurons in the dorsal raphe (DR), with implications for anxiety and depression, has also been described (Hauger *et al.* 2006; Meloni *et al.* 2008).

Corticotropin-releasing factor also binds to CRF-binding protein (CRF-BP), which is found centrally and peripherally (Alderman & Bernier 2007; Manuel *et al.* 2014; Potter *et al.* 1992). Several central locations are listed in Figure 1. The CeA is a particularly CRF-BP dense region (Alderman & Bernier 2007; Potter *et al.* 1992). Some of the proposed functions of CRF-BP are to restrict transport/release of CRF in some centrally located pathways (Potter *et al.* 1992), aid in protecting CRF from degradation once it has been released

(Seasholtz *et al.* 2002) and modulate CRF-induced potentiation of glutamate receptor function via CRF<sub>2</sub> actions (Ungless *et al.* 2003).

The complexity of the CRF system is further increased by the existence of additional endogenous agonists. Corticotropin-releasing factor receptors can be activated by the urocortin (Ucn) family of neuropeptides: Ucn<sub>1</sub>, Ucn<sub>2</sub> and Ucn<sub>3</sub>. Urocortin<sub>1</sub> binds with similar affinity to CRF<sub>1</sub>, CRF<sub>2</sub> and CRF-BP, whereas Ucn<sub>2</sub> and Ucn<sub>3</sub> bind primarily to CRF<sub>2</sub> (Bittencourt *et al.* 1999; Lewis *et al.* 2001; Reyes *et al.* 2001; Ryabinin *et al.* 2012; Vaughan *et al.* 1995). Urocortin<sub>1</sub> is predominantly expressed in the centrally projecting Edinger–Westphal (EWcp) nucleus (Bittencourt *et al.* 1999; Kozicz *et al.* 1998; Ryabinin *et al.* 2005; Vaughan *et al.* 1995). Note that two divisions of the EW have been named EWcp and EWpg (preganglionic), based on cell groups and projections (Kozicz *et al.* 2011). Cells in the EWcp contain stress- and feeding-related neuropeptides, such as Ucn<sub>1</sub>, whereas the EWpg contains neurons that control oculomotor function and send cholinergic inputs to the ciliary ganglion. Urocortin<sub>2</sub> and Ucn<sub>3</sub> are more widely distributed than Ucn<sub>1</sub>. Among other structures, Ucn<sub>2</sub> is present in the hypothalamus (PVN and arcuate nucleus) and the locus coeruleus, and Ucn<sub>3</sub> is expressed in several brain structures, including the BNST and the medial nucleus of the amygdala (Cavalcante *et al.* 2006; Deussing *et al.* 2010; Lewis *et al.* 2001; Li *et al.* 2002; Reyes *et al.* 2001; Tanaka *et al.* 2003).

The CRF system has a key role in mood disorders (Aubry 2013; Kormos & Gaszner 2013). Activation of CRF<sub>1</sub> and CRF<sub>2</sub> has been associated with negative emotionality, anxiety-like behavior and the behavioral responses to stress, with CRF<sub>1</sub> thought to be responsible for the initiation of such responses and CRF<sub>2</sub> mediating termination and recovery (Coste *et al.* 2006; Hauger *et al.* 2006; Janssen & Kozicz 2013). The roles of CRF<sub>1</sub> and CRF<sub>2</sub> in behavior have also been interpreted with regard to their involvement in responses to (real or perceived) escapable vs. inescapable stressors. For example, CRF<sub>1</sub> mediates active defensive responses to escapable stressors, and CRF<sub>2</sub> mediates responses to inescapable, uncontrollable stressors that could be associated with anxiety and depression vulnerability (Hauger *et al.* 2006). The involvement of CRF and Ucn peptides in stress-induced feeding behavior has received considerable attention (Stengel & Tache 2014), and mounting evidence is supporting involvement of CRF and Ucn in different aspects of social behavior (for a review, see Hostetler & Ryabinin 2013).

Overall, CRF systems play an important role in regulating a number of functions with key implications for adaptive behavior, motivation and emotion. Over the last three decades, special emphasis has been placed on the understanding of the behavioral relevance of stress- and drug-induced long-term changes in CRF system neurophysiology. This brief description does not do justice to a rich literature pertaining to a wide range of behaviors that involve CRF<sub>1</sub> and CRF<sub>2</sub> signaling, and the reader is referred to the reviews cited above. In the next section, we focus on the role of CRF and its receptor in the context of addiction, and specifically its importance in EtOH intake, changes in intake and behavioral traits that reflect neuroplasticity induced by chronic EtOH exposure. Figure 2 illustrates some of the central CRF-related neurocircuitry that may be involved in EtOH-related phenotypes discussed in this review. For example, the CeA and BNST play important roles in negative emotional states that drive chronic EtOH use in some individuals; the basolateral amygdala

(BLA) further affects this circuit. The periaqueductal gray, in its role as an important functional interface between the forebrain and lower brainstem, has a probable effect as an integrator of behavioral responses to stressors, both internal and external. The prefrontal cortex has well-known executive functions that affect not only craving and habit formation via interactions with other brain nuclei, such as the dorsal striatum (not shown here), but also basic reinforcement and conditioned reinforcement via the NAcc shell and core, respectively, which sustain use and impact relapse. Also, receptor types found in the included brain regions and transmitters in neural pathways that direct communication are included in Fig. 2. For example, the PVN is a critical regulator of stress responses and is modulated by a serotonergic projection from the DR. For additional important information, the reader is referred to papers and figures that consider disorders that are co-morbid with addiction (Gilpin 2014; Reul & Holsboer 2002) and articles that discuss important functional differences of sub-regions of structures, such as the prefrontal cortex (George & Koob 2010; Lu & Richardson 2014; Marchant *et al.* 2014) and CeA (Duarci & Pare 2014; Gilpin 2014).

### Addiction and the CRF system: a common pathway for drugs of abuse

One psychopathology commonly associated with CRF dys-regulation and stress is drug addiction. All drugs of abuse, regardless of specific mechanism of action, induce activation of CRF signaling and the HPA axis (for reviews, see Armario 2010; McReynolds *et al.* 2014), and their effects are modulated by stress (Aguilar *et al.* 2013; Picetti *et al.* 2013; Roberts *et al.* 1995; Stephens & Wand 2012). Additionally, these addictive substances produce important CRF-mediated and stress-influenced long-lasting neuroadaptations that have been suggested to explain key aspects of the development and maintenance of the addictive phenotype (Koob 2013; Koob & Le Moal 2001; Leyton & Vezina 2014; Robinson & Berridge 1993, 2008; Wise & Koob 2014; Zorrilla *et al.* 2014).

All abused drugs sensitize mesolimbic DA mechanisms and induce behavioral sensitization to their stimulant effects; in fact, behavioral, or psychomotor, sensitization has been used extensively as a measurable phenotype of such underlying neuroplasticity (Robinson & Berridge 1993, 2008; Sanchis-Segura & Spanagel 2006). Mesocorticolimbic DA signaling has been associated with different components of positive reinforcement and reward processes, including activation, motivation, incentive salience, ‘wanting’ (but not necessarily ‘liking’), effort, goal-directed behavior and reward-related learning (Berridge & Kringelbach 2013; Salamone & Correa 2012; Schultz 2013; but also see Wise 2008). Long-lasting upregulation of DA mechanisms has been linked to unmanageable pathological motivation and compulsive drug seeking and taking characteristic of addiction. Evidence indicates that stress produces a CRF-mediated activation of DA systems that is comparable to that induced by addictive substances (Sinha 2008). This is, moreover, an effect that appears to be especially critical during adolescence, a time when maturing DA systems show increased sensitivity to stress hormones (Burke & Miczek 2014; Sinclair *et al.* 2014). Cross-sensitization between stressors and addictive drugs, including EtOH (Roberts *et al.* 1995), has also been described. Additionally, research on humans has shown that stress elevates striatal extracellular DA levels (Adler *et al.* 2000; Soliman *et al.* 2008). Stress and CRF activation can therefore be understood as key facilitators of drug-induced neuroplasticity in

mesocorticolimbic DA systems associated with dysregulation of positive reinforcement mechanisms in addiction.

Abused drugs and stress also produce enduring changes within CRF systems. Long-lasting dysregulation of extra-hypothalamic CRF mechanisms (primarily extended amygdala, and also prefrontal cortex neurocircuitry) have been linked to the negative emotionality, anxiety and vulnerability to stress seen in addicts (Gerra *et al.* 2014; Thorberg & Lyvers 2006; Valdez & Koob 2004). As discussed in greater detail below for EtOH, drug-induced activation of brain stress response systems sensitizes over time, especially with repeated withdrawal, and this sensitization has been seen to persevere into protracted abstinence, critically contributing to the persistence of relapse. Extra-hypothalamic CRF dysregulation is a key biological mechanism underlying manifestation of negative emotional states associated with drug abstinence, even well beyond the time when physical symptoms of withdrawal are seen (Koob 2014; Koob & Le Moal 2008). However, important HPA axis-dependent effects, such as upregulation of glucocorticoid receptors (GRs) in the CeA, associated with protracted EtOH abstinence, indicate that both hypothalamic and extra-hypothalamic mechanisms interact and participate in critical aspects of long-lasting drug-induced neuroadaptation (Vendruscolo *et al.* 2012). Overall, strong scientific support suggests that dysregulation of positive and negative reinforcement mechanisms, which underlie pathological motivation associated with drug craving and increased negative emotionality and vulnerability to stress, critically involve the CRF system.

Corticotropin-releasing factor and stress-axis involvement have received particular attention in the context of the investigation of the neurobiological effects of EtOH. At a neurophysiological level, laboratory animal and human research show that systemic administration of EtOH increases CRF and induces HPA axis activation (Jenkins & Connolly 1968; Pastor *et al.* 2008, 2011; Rivier 1996). Although the precise mechanism by which EtOH stimulates stress systems and hormones is yet to be fully described, growing evidence indicates that this is a central, CRF/CRF<sub>1</sub>-mediated effect (recently reviewed by Armario 2010). Convincing support for this conclusion arises from a number of studies showing HPA axis activation with systemic or intracerebroventricular (ICV) administration of EtOH (Lee *et al.* 2004; Ogilvie *et al.* 1998), as well as a blunted HPA response to EtOH in CRF<sub>1</sub> null mutant mice (Lee *et al.* 2001b; Pastor *et al.* 2008) or after administration of a CRF antiserum (Rivier *et al.* 1984).

Hypothalamic regulation of glucocorticoids is altered by a history of EtOH exposure; human and rodent data show that repeated EtOH produces an increase in baseline levels of CORT, with a flattening of natural glucocorticoid circadian level variations and a diminished response to stress challenges (Errico *et al.* 1993; Lee & Rivier 1997; Lee *et al.* 2001a; Rasmussen *et al.* 2000; Wand & Dobs 1991). However, the effects of chronic EtOH and EtOH withdrawal on CRF systems are complex and depend on EtOH administration procedures, time of measurement and whether other stressful stimuli are included in the study design (for a review, see Allen *et al.* 2011). For example, one study examined the effect of 14 days of continuous EtOH vapor exposure in Sprague–Dawley rats and found a decrease in the number of CRF-binding sites in the pituitary when tissue was taken immediately after withdrawal from EtOH (Dave *et al.* 1986). However, in another study,



again in Sprague–Dawley rats, 7 days of continuous vapor exposure were associated with decreased hypothalamic CRF content in tissue obtained immediately after withdrawal (Rivier *et al.* 1984). A change in the same direction in these two studies suggests that the decrease in receptors was not a compensatory change; however, the methods were not identical in the two studies, complicating interpretation. A number of studies examining CRF-related effects have used intermittent, rather than continuous, vapor exposure procedures. For example, using a 6 h/day, 8-day EtOH vapor exposure period, CRF stores in the external zone of the median eminence of Sprague–Dawley rats were decreased; tissue was taken ~12 h after withdrawal (Lee *et al.* 2000). Criado *et al.* (2011) exposed Wistar rats to EtOH vapor for 14 h/day for either 2 or 8 weeks and then examined CRF immunoreactivity in the amygdala, frontal cortex, hippocampus and parietal cortex immediately, 24 h or 2 weeks after withdrawal from EtOH vapors. No significant effects were found in the rats exposed for 2 weeks. However, increased CRF immunoreactivity was found in the hippocampus and parietal cortex of rats exposed for 8 weeks, when examined 24 h or 2 weeks, but not immediately, after withdrawal. These and other data not reviewed here (Koob & Zorrilla 2010; Läck *et al.* 2005; Richardson *et al.* 2008a; Sommer *et al.* 2008; Uhart & Wand 2009) show that effects of chronic EtOH exposure on CRF systems cannot be defined without careful consideration of methodological details. Furthermore, factors such as sex, species and age of stress or EtOH exposure should be considered (Logrip *et al.* 2013; Przybycien-Szymanska *et al.* 2010, 2011; Silva *et al.* 2009; Van Waes *et al.* 2011).

At a behavioral level, EtOH consumption, abuse and relapse have been observed to be critically modulated by CRF and stress, and there is a high incidence of co-morbidity between alcoholism and stress-associated disorders such as anxiety and depression (Boden & Fergusson 2011; Haass-Koffler *et al.* 2014; Lijffijt *et al.* 2014). Furthermore, abnormally high levels of CORT, a condition known as pseudo-Cushing's syndrome (Kirkman & Nelson 1988), are frequently found in alcoholics. Laboratory animal research has provided support for participation of the CRF system in stress-induced changes in EtOH effects and in EtOH-induced neuroadaptations that are reflected in behavioral changes (Fig. 3). In the following sections, we review literature focusing on the involvement of stress, and components of the CRF system, in EtOH consumption and the behavioral aspects of EtOH-induced neuroadaptation. Tables 1 and 2 list many of the studies in these areas, with Table 1 providing references, trait information and results for knockout (KO) and transgenic mouse studies, and Table 2 providing detailed information for pharmacological studies. We do not exhaustively review the literature on the effects of EtOH on CRF-related peptide levels; that is beyond the scope of this review. We refer to specific literature, but the reader is referred to the tables for details such as animal species, genotype and methods associated with EtOH and other drug treatments.

## The role of CRF systems in EtOH intake

A large number of studies have supported a role for CRF and CRF-related systems in EtOH intake, which has led to considerable interest in the potential of CRF-related pharmaceuticals as treatments for alcohol use disorders (Egli 2005; Heilig & Koob 2007; Zorrilla *et al.* 2013). EtOH intake has been examined using multiple procedures, including two-bottle choice continuous access, operant self-administration to get at strength of

reinforcement and reinstatement of EtOH seeking (discussed in greater detail in the section on the role of CRF systems in EtOH-induced neuroadaptation), and limited access 'drinking in the dark' (DID) procedures to obtain binge-like levels of intake. Papers and findings are listed in Tables 1 and 2, and several reviews have covered much of the literature (see reviews cited above). We highlight some of the findings here.

### Single gene mutant mice

Only four papers had been published using single gene manipulations in mice to examine the influence of CRF-related genes on EtOH intake by the time of a 2006 general review of EtOH-related genes (Crabbe *et al.* 2006). Since then, many additional papers have appeared (Table 1). In the initial study examining EtOH intake in CRF KO mice, KO mice consumed more EtOH than did wild-type (WT) mice in both a 24-h continuous access procedure and a limited access procedure (Olive *et al.* 2003). The opposite phenotype was found in CRF overexpression mice that were examined for their continuous access EtOH drinking phenotype (Palmer *et al.* 2004). However, more recently, Kaur *et al.* (2012) reported reduced EtOH intake in CRF KO mice in a binge-like DID study. The opposite findings in CRF KO mice could be related to the role of CRF in procedures in which EtOH intake is generally lower (Olive *et al.* 2003) vs. higher (Kaur *et al.* 2012).

Several studies have examined the role of CRF<sub>1</sub> using KO mice, and results have not been entirely in agreement. The first study examining EtOH intake in constitutive CRF<sub>1</sub> KO mice found no initial effect, but reported a long-term increase in continuous access EtOH consumption in CRF<sub>1</sub> KO mice after repeated stress exposure that was not seen in their WT controls (Sillaber *et al.* 2002). In that report, initial EtOH intake levels were low (~1 g/kg/24 h) and stress-induced levels remained relatively low (<4 g/kg/24 h). A more recent paper, using the same KO mice, obtained data that are in agreement with those findings (Molander *et al.* 2012). However, other studies have found reduced EtOH intake in constitutive CRF<sub>1</sub> KO mice, specifically when EtOH was offered at higher concentrations (20%) or using a DID procedure, and thus, when EtOH intake was generally higher in the WT littermate mice (Giardino & Ryabinin 2013; Kaur *et al.* 2012; Pastor *et al.* 2011). In addition, also inconsistent with Sillaber *et al.* (2002), are studies in which forced swim or social defeat stress-induced increases in EtOH intake have been found to be absent or reduced in CRF<sub>1</sub> KO mice (Molander *et al.* 2012; Pastor *et al.* 2011); furthermore, EtOH withdrawal-induced increases in EtOH self-administration and intake were not seen in CRF<sub>1</sub> KO mice (Chu *et al.* 2007; Molander *et al.* 2012). One difference in the studies that have found reduced intake and a lack of stress response is that the KO mice were backcrossed onto the EtOH-preferring C57BL/6J mouse strain for several generations. In fact, Molander *et al.* (2012) also found that stress-induced increases in EtOH consumption were lower in a brain-specific CRF<sub>1</sub> KO that was on a mixed 129S2/Sv × C57BL/6J × SJL strain background. In general, the majority of the data suggest that adequate CRF<sub>1</sub> function is important for higher levels of EtOH intake and for stress-induced changes in EtOH intake.

Because receptor-specific antagonists for CRF<sub>2</sub> that can be administered peripherally are not available, information about the involvement of CRF<sub>2</sub> signaling in EtOH-related phenotypes has relied mostly on studies in CRF<sub>2</sub> KO mice. In general, data have suggested a modulatory



role on the more significant involvement of CRF<sub>1</sub> in stress-related responses (Coste *et al.* 2000, 2006). The initial study in CRF<sub>2</sub> KO mice examined both continuous and limited access EtOH drinking. No effect of the mutation was found in the continuous access study. The limited access study included 30-min access periods as the EtOH concentration was increased, followed by 2-h access periods. A modest difference in intake (KO > WT) was found for some concentrations during the 30-min access phase that was not sustained when the access period was increased (Sharpe *et al.* 2005). In a more recent study, a small transient reduction in EtOH intake was seen in CRF<sub>2</sub> KO mice that appeared to be largely in males (Kaur *et al.* 2012). Therefore, this receptor subtype has not had a sustained effect on EtOH consumption in the studies that have been conducted thus far.

### Pharmacological studies

Intracerebroventricular administration of CRF has been found to decrease EtOH consumption in rats and mice (Bell *et al.* 1998; Ryabinin *et al.* 2008; Thorsell *et al.* 2005), which is consistent with reduced EtOH intake in CRF overexpression mice (Palmer *et al.* 2004). However, some data suggest non-specific effects on fluid intake (Ryabinin *et al.* 2008). Centrally administered CRF has also been found to reinstate EtOH seeking behavior (Le *et al.* 2002), which is consistent with its role as a stressor. Results for the effect of the other endogenous CRF<sub>1/2</sub> agonist peptide, Ucn<sub>1</sub>, on EtOH intake have been dependent upon brain region, as intra-DR application had no effect, but intra-lateral septum infusion reduced both established EtOH intake and the acquisition of EtOH drinking (Ryabinin *et al.* 2008). Overall, the majority of the data appear to indicate that drugs that have combined agonist actions at CRF<sub>1</sub> and CRF<sub>2</sub> receptors reduce EtOH intake (see CRF and Ucn<sub>1</sub> entries in Table 2).

On the other hand, there is a large body of data showing that reduced CRF<sub>1</sub> signaling via receptor antagonist administration also reduces EtOH intake. As this literature has evolved, it has become more apparent that CRF<sub>1</sub> antagonists have greater effects when EtOH intake levels are high. For example, subcutaneous administration of the CRF<sub>1</sub> antagonist, *N,N*-bis(2-methoxyethyl)-3-(4-methoxy-2-methylphenyl)-2,5-dimethyl-pyrazolo [1,5-*a*]pyrimidin-7-amine, attenuated elevated levels of EtOH intake seen in alcohol preferring (P) rats after dependence induction, while not affecting EtOH intake in non-dependent P rats (Gilpin *et al.* 2008). Similarly, operant responding for EtOH was decreased by several different CRF<sub>1</sub> (or CRF<sub>1/2</sub>) antagonists in EtOH-dependent, but not in non-dependent, animals (Finn *et al.* 2007; Funk *et al.* 2006; Overstreet *et al.* 2007; Sabino *et al.* 2006), and these drugs tend to reduce binge-like or stress-induced heightened EtOH intake, with less consistent effects on more modest levels of intake (Cippitelli *et al.* 2012; Lowery *et al.* 2008; Lowery-Gionta *et al.* 2012; Simms *et al.* 2014). However, not all studies have consistently supported this generalization. For example, a significant restraint stress-induced increase in EtOH consumption in 129SVEV mice was not blocked by the CRF<sub>1</sub> antagonist, R121919 (Yang *et al.* 2008), and CP-154,526 reduced intake under both higher and lower intake conditions in mice and rats (Hwa *et al.* 2013). Also, lesioning the CeA, which would be expected to affect neurons that are relevant to CRF-related pathways, did not prevent heightened levels of EtOH intake seen in C57BL/6J mice after dependence induction (Dhafer *et al.* 2008). Finally, Sharpe and Phillips (2009) showed that the selective CRF<sub>2</sub>

agonist, Ucn<sub>3</sub>, delivered centrally to non-dependent C57BL/6J mice, reduced 2-h limited access 10% EtOH consumption. This study used lickometers to investigate drinking patterns, and identified that reduced EtOH drinking by Ucn<sub>3</sub> was associated with a change in size of the largest drinking bouts. Lowery *et al.* (2010) also found that ICV infusions of Ucn<sub>3</sub> reduced binge-like EtOH drinking in C57BL/6J mice.

In conclusion, growing evidence from studies using both single gene mutant mice and pharmacology indicates that voluntary EtOH intake can be mediated by CRF signaling via CRF<sub>1</sub>. CRF<sub>1</sub> appears to play a key role in acquisition of EtOH drinking when high levels of intake are achieved via binge-like drinking, genetic predisposition, exposure to high concentrations of EtOH or a combination of these conditions. Current literature also suggests that the enhancing effects of stress on EtOH drinking are mediated by CRF<sub>1</sub>, although results may be influenced by species, genotype and methodological factors. A significant literature supports the view that increased EtOH drinking seen after long-term, dependency inducing periods of exposure to EtOH and EtOH-induced negative emotionality and anxiety associated with post-dependent states are mediated, at least in part, by CRF<sub>1</sub>. CRF<sub>2</sub> appear to play a more minor role.

### Effects of EtOH drinking on CRF and related molecules

We have focused on the ability to manipulate EtOH drinking and EtOH-induced neuroplasticity by genetically or pharmacologically altering relevant components of the CRF system. However, a few comments about the changes in this system induced by EtOH drinking are pertinent. A relatively early study examined the effect of different levels of voluntary EtOH drinking on brain CRF levels. Wistar rats were classified as low, moderate and high intake and then examined for CRF concentration in several brain regions. Rats classified as high drinkers had higher non-median eminence hypothalamic CRF concentrations, but lower neurointermediate pituitary and pons-medulla CRF concentrations (George *et al.* 1990). It should be noted that the different drinking levels in these Wistar rats could have had genetic, environmental or both types of influences as their source. In a more recent study, the number of CRF-positive cells in the CeA was higher in adult mice immediately after a binge-like EtOH drinking episode (Lowery-Gionta *et al.* 2012). This relationship appears to be altered when EtOH exposure occurs at an earlier, more distant time point, as CRF cell counts in the CeA were reduced, rather than increased, in adult rats that had a history of adolescent binge drinking (Gilpin *et al.* 2012), and so was CRF mRNA in the BLA (Falco *et al.* 2009). However, adolescent rats may have a higher basal level of CRF in some brain regions, including the CeA, compared with adult rats, which could affect the response of this system (Wills *et al.* 2010).

Some studies have examined the effect of pre-existing genetically-determined differences in EtOH preference. When the effect of voluntary EtOH drinking on CRF mRNA levels was examined in selectively bred Sardinian alcohol preferring (sP) rats, CRF mRNA levels were decreased in the CeA, but not in hypothalamus (Zhou *et al.* 2013). Furthermore, data for individual animals showed a significant negative correlation between intake and CRF mRNA level in the amygdala. Of course, it is impossible to compare this outcome to that in the oppositely selectively bred non-preferring line, because they will not voluntarily consume

much EtOH. However, innate differences in pairs of selected lines can be examined. For example, when lines of rats bred for high and low EtOH drinking were compared in the EtOH-naïve state, CRF-positive cells and CRF mRNA were significantly lower in the CeA of alcohol preferring (P), compared with alcohol non-preferring (NP) rats, but not in the high alcohol drinking (HAD), compared with low alcohol drinking (LAD) rats (Hwang *et al.* 2004). Thus, the data are inconsistent with regard to levels of these CRF-related peptides as predictors of genetically determined tendency to consume EtOH. In addition, several lines of rats have been compared for native differences in Ucn<sub>1</sub>-positive cells in the EWcp, with mixed findings; a greater number of Ucn<sub>1</sub> cells was found in the preferring line in two of the five surveyed pairs; a lower number in one preferring compared with non-preferring; and no difference was found in two of the five pairs (Turek *et al.* 2005). On the other hand, data from these rat lines were more consistent in showing a greater number of Ucn<sub>1</sub>-positive projections to the lateral septum in association with EtOH preference (Turek *et al.* 2005). Furthermore, using immunohistochemistry, three sublines of alcohol-preferring rats were compared with control Wistar rats for Ucn<sub>1</sub>-positive cells in the EWcp. The number of Ucn<sub>1</sub>-positive cells was greater in male P, compared with Wistar rats; a similar non-significant trend was found in female animals (Fonareva *et al.* 2009). Therefore, there are again contradictory findings, with regard to whether number of Ucn<sub>1</sub>-positive cells serves as a marker for differences in genetically determined EtOH preference. Some of this variability in results could be related to the heterogeneous nature of the underlying genetic factors for EtOH drinking.

### Other genetic findings

A few studies have provided evidence of associations of genetic polymorphisms in CRF-related genes with EtOH drinking phenotypes. The rhesus macaque *CRH* gene has been sequenced and examined for functional variants. One variant (-2232C→G) was shown to decrease DNA-protein interactions and decrease sensitivity of the *CRH* promoter to glucocorticoids in an *in vitro* assay. This variant was also associated with reduced CRF in the cerebral spinal fluid, and increased plasma ACTH, under non-stress conditions. It was also associated with increased EtOH consumption in adult macaques. The authors state that the genetic effect was specifically in macaques that were mother-reared in social groups, as opposed to macaques that were first isolate reared by human caregivers and then placed with peers from 37 days forward; however, intake data were not presented for the latter group (Barr *et al.* 2008). A single nucleotide polymorphism (SNP) within the rhesus macaque *CRH* promoter (-248C→T) was found to increase DNA-protein interactions and to increase EtOH consumption in animals that were isolate-peer reared, but not mother-reared. These monkeys also exhibited a larger stress-axis response to social separation stress (Barr *et al.* 2009). The authors suggested that effects of mutations may be specific to environmental conditions. Thus, for example, some may have effects under social drinking situations and others may affect stress-related drinking.

The electroencephalographic response to CRF was examined in P and NP rats as a marker of CRF-induced neural activation. P rats exhibited a larger response, compared with NP rats, and a lower basal concentration of CRF was found in P rats in several brain regions. These results led to the speculation that CRF receptors may be upregulated in P rats and that these

differences in CRF neural regulation may contribute to differences in EtOH consumption (Ehlers *et al.* 1992). Subsequently, the finding of lower CRF in P rats was confirmed, but it was not replicated in another set of HAD and LAD lines (Hwang *et al.* 2004). Also, basal CRF levels in the CeA of sP rats were higher than in Sardinian non-preferring (sNP) rats (Richter *et al.* 2000; Zhou *et al.* 2013), a region where it had been found to be lower in P rats (Ehlers *et al.* 1992; Hwang *et al.* 2004). Furthermore, no difference was found between the high EtOH drinking C57BL/6J and EtOH avoiding DBA/2J mouse strains (Hayes *et al.* 2005). Therefore, a clear relationship between CRF level and genetically determined level of EtOH intake is not apparent. However, differences in innate anxiety level found between the P and NP (P > NP) rats, but not between HAD and LAD rats, may reflect variation in the specific genes involved in the selection traits across EtOH consumption selected lines and also support significant involvement of CRF specifically in anxiety-or stress-related drinking. Based on human SNP association analysis, Enoch *et al.* (2008) suggested that the CRF-BP gene (*CRHBP*) plays a role in stress-related EtOH use. However, a negative, rather than positive, correlation was found between level of anxiety-like behavior and CRF level in sP and sNP rats. Chen *et al.* (2010) suggested a role for *CRHR1* genetic variation in vulnerability to alcohol use disorder, and Treutlein *et al.* (2006) suggested an association of *CRHR1* polymorphisms with pattern of alcohol consumption. Additional genetic investigations will be needed to substantiate these relationships and identify gene networks that are likely to influence complex alcohol-related traits and possibly be population-specific.

A SNP in the promoter region of the CRF<sub>1</sub> gene (*Crhr1*) of the Marchigian–Sardinian preferring (mSP) rat may influence their heightened stress-induced EtOH drinking phenotype. This polymorphism results in upregulation of *Crhr1* in several brain regions, compared with levels seen in control Wistar rats. When these rats were treated with a CRF<sub>1</sub> antagonist, stress-induced reinstatement of EtOH drinking was blocked in mSP, but not in Wistar, rats (Hansson *et al.* 2006). Furthermore, chronic free-choice EtOH drinking was associated with downregulation of the CRF<sub>1</sub> protein in the amygdala and NAcc (Hansson *et al.* 2007). The authors suggested that heightened levels of CRF<sub>1</sub> drive excessive EtOH intake, which consequently reduces CRF<sub>1</sub> activity.

Because the gene coding for CRF<sub>2</sub> (*Crhr2*) maps to a genetic region associated with EtOH consumption, specifically in the inbred P and NP rats, *Crhr2* expression and sequence were examined and a receptor function assay was performed. Lower levels of *Crhr2* expression were found in P rats in some brain regions. In addition, a 7 base pair insertion polymorphism in the promoter region of the gene was found in the P rat, as well as a coding region polymorphism and an amino acid deletion in the 3' untranslated region. The effect of the promoter insertion *in vitro* was to lower *Crhr2* expression, and CRF<sub>2</sub> density in the amygdala was lower in P, compared with NP rats (Yong *et al.* 2014). Whether these differences directly relate to differences in EtOH consumption between P and NP rats will require further investigation.

## The role of CRF systems in EtOH-induced neuroadaptation

### Dependence, withdrawal and relapse

One potential consequence of repeated EtOH administration is the development of dependence. Dependence can be inferred from certain symptoms that may be seen when chronic EtOH is withdrawn. Affective symptoms associated with EtOH withdrawal include increased anxiety, dysphoria and depressed mood, symptoms that have been posited to involve changes in the stress axis and central CRF-mediated process (Breese *et al.* 2005a; Ciccocioppo *et al.* 2009; Clapp *et al.* 2008; Griffin 2014; Koob 2010; Koob *et al.* 2014; Lowery & Thiele 2010; Shalev *et al.* 2010; Zorrilla *et al.* 2013). In addition, repeated bouts of EtOH exposure and withdrawal have been associated with escalation of EtOH intake (see description and history of this model in Vendruscolo & Roberts 2014) and a number of studies have explored the involvement of CRF systems in this effect, and in reinstatement of EtOH drinking and seeking, as traits relevant to relapse.

### Single gene mutant mice studies

Few studies have utilized mutant mice to investigate the role of the CRF system in EtOH withdrawal-related effects. When CRF<sub>1</sub> KO and WT mice were made dependent on EtOH using a liquid diet, the KO mice did not exhibit withdrawal-induced increased EtOH seeking, whereas WT mice did; KO and WT mice were similar in EtOH seeking in the non-dependent state (Chu *et al.* 2007). The same paper reported that the CRF<sub>1</sub> antagonist, antalarmin, blocked withdrawal-induced increases in EtOH seeking in C57BL/6J background strain mice made dependent using EtOH vapor inhalation. These data support CRF<sub>1</sub> involvement in dependence-induced increases in EtOH seeking. We were not able to find additional studies examining effects in CRF-related KO mice.

### Pharmacological studies

A number of studies have investigated the role of CRF and its related peptides in withdrawal-induced increases in EtOH drinking or self-administration using pharmacological manipulations. Data collected in C57BL/6J mice, in which a CRF<sub>1/2</sub> antagonist was microinjected into the CeA, showed a decrease in EtOH withdrawal-associated EtOH intake in the absence of an effect on non-dependent mice (Finn *et al.* 2007). A larger number of studies have examined the specific involvement of CRF<sub>1</sub> and there is general agreement that CRF<sub>1</sub> antagonists attenuate withdrawal-associated increases in EtOH drinking/self-administration (Chu *et al.* 2007; Funk *et al.* 2007; Gehlert *et al.* 2007; Overstreet *et al.* 2007; Roberto *et al.* 2010; Sabino *et al.* 2006). In most cases, the CRF<sub>1</sub> antagonist effects did not generalize to non-dependent animals; however, in one study that examined EtOH intake during operant sessions, rather than number of reinforcers, attenuating effects of R121919 were seen in both dependent and non-dependent rats (Roberto *et al.* 2010). It is worth mentioning, however, that in this study, repeated R121919 treatment was given 24 h before each operant testing session.

A few studies have examined the role of CRF<sub>2</sub>. One study examined EtOH withdrawal-associated increased self-administration after intra-CeA infusion of Ucn<sub>3</sub> and attenuation was found (Funk & Koob 2007); however, EtOH self-administration in the non-dependent

rats in this study was increased by intra-CeA Ucn<sub>3</sub> infusion. Others have found decreased EtOH intake with ICV infusion of Ucn<sub>3</sub> in C57BL/6J mice using DID procedures in which higher levels of EtOH intake are induced (Lowery *et al.* 2010; Sharpe & Phillips 2009). Therefore, while studies on KO mice do not appear to support a role for CRF<sub>2</sub>, these pharmacological studies suggest that both CRF<sub>1</sub> and CRF<sub>2</sub> may influence higher levels of EtOH intake.

In mice made dependent using EtOH liquid diet, the non-selective CRF receptor antagonist  $\alpha$ -helical CRF<sub>(9-41)</sub>, given ICV, blocked the anxiogenic-like effects of EtOH withdrawal on the elevated plus maze, but did not alter other withdrawal symptoms, including tail stiffness, tremor or ventromedial distal flexion (Baldwin *et al.* 1991). The attenuating effect of CRF receptor antagonism on the anxiogenic-like response has been replicated (Valdez *et al.* 2003). Further, when CRF was microinjected into several brain regions, but not others (see Table 2), dose-dependent sensitization of an EtOH withdrawal-induced decrease in social interaction was seen (Huang *et al.* 2010), which has been posited to be an anxiety-like behavior (File 1980). Examination of the brain regions that supported these effects suggests that the extended amygdala is involved in withdrawal-associated anxiogenic behaviors. Several additional studies have used the social interaction test, as a behavioral index of anxiety-related behavior and have found that CRF<sub>1</sub> receptor-selective antagonists given during EtOH withdrawal can blunt anxiety-like behavior (Breese *et al.* 2004, 2005b; Knapp *et al.* 2004; Overstreet *et al.* 2007; Sommer *et al.* 2008; Wills *et al.* 2009). Furthermore, the CRF<sub>1</sub>-selective antagonist, SSR125543, blocked CRF- and stressor-sensitized withdrawal-induced anxiety-like behavior (Breese *et al.* 2005b; Huang *et al.* 2010; Knapp *et al.* 2011a). However, the endogenous CRF<sub>2</sub>-selective agonist, Ucn<sub>3</sub>, given ICV or into several brain regions, did not affect EtOH withdrawal-associated anxiogenic effects (Huang *et al.* 2010), nor did the CRF<sub>2</sub> antagonist antisauvagine-30 (Overstreet *et al.* 2004). Taken together, these results suggest that CRF<sub>1</sub> plays a role in withdrawal-induced anxiogenic behaviors.

The role of CRF signaling has also been extensively studied in the context of behaviors thought to model relapse; in particular, reinstatement of EtOH seeking/drinking behavior in rodents. Corticotropin-releasing factor signaling involvement in escalation of use after periods of deprivation has also been examined. Most commonly, reinstatement studies have used operant methods in which animals are trained to perform an operant response to gain access to a reservoir or sipper containing EtOH, and then, once stable responding is achieved, extinction procedures are used that lead to low levels of the behavior that previously resulted in EtOH access. Post-extinction, active drug taking or seeking behavior (responding in the absence of drug delivery) can be re-established by drug priming, presentation of cues that were previously associated with drug availability or application of a stressor. In the case of EtOH, CRF signaling appears to play an important role in those mechanisms that particularly mediate stress-induced reinstatement, but not in those that facilitate drug prime or cue/context-induced reinstatement. For example, CRF<sub>1</sub> antagonists selectively reduce footshock-induced reinstatement of responding for EtOH (Le *et al.* 2000; Liu & Weiss 2002), an effect that appears to be especially prominent in EtOH-dependent or genetically selected EtOH preferring rats and is mediated by extra-hypothalamic mechanisms (Gehlert *et al.* 2007; Le *et al.* 2000; Liu & Weiss 2002). In addition, CRF signaling via CRF<sub>1</sub> modulates pharmacologically-induced stress effects on EtOH



reinstatement; thus, stress-axis activation induced by yohimbine, an  $\alpha 2$  adrenoreceptor antagonist that activates the ascending noradrenaline system and increases anxiety-like responses, reinstates responding for EtOH. This reinstatement is prevented by CRF and CRF<sub>1</sub> antagonism (Le *et al.* 2000, 2002; Marinelli *et al.* 2007), which appears to be mediated by CRF receptors in the median raphe nucleus (Le *et al.* 2013). On the other hand, the NAcc appears to be an important brain structure involved in the role of CRF in stress-induced escalation of EtOH intake during periods of deprivation. For example, when EtOH-preferring P rats that have a history of EtOH drinking are re-introduced to EtOH, intake can be increased as a consequence of exposure to restraint stress administered during a period of EtOH deprivation; this effect was prevented by intra-NAcc injection of a CRF<sub>1</sub> antagonist (Knapp *et al.* 2011a). Furthermore, increased EtOH intake can be induced by intra-NAcc administration of CRF during the deprivation period (Knapp *et al.* 2011a). For a review of additional research examining stress-induced reinstatement of drug seeking and the role of CRF (among other neuropeptides), see Shalev *et al.* (2010).

## Psychomotor sensitization

The body of data examining the role of CRF-related systems in behavioral sensitization to EtOH is small. However, data from both single gene KO mice and pharmacology have consistently indicated that CRF and CRF<sub>1</sub>, but not CRF<sub>2</sub> and Ucn<sub>1</sub>, play important roles in the neuroadaptations that underlie the development and expression of psychomotor sensitization to EtOH (Fee *et al.* 2007; Pastor *et al.* 2008, 2012; Phillips *et al.* 1997). Repeated restraint stress was previously shown to produce psychomotor sensitization to EtOH through a mechanism that involves CORT and GR (Roberts *et al.* 1995). More recent results from our laboratory and other research groups have shown a key role of CRF and CRF<sub>1</sub> in EtOH-induced psychomotor sensitization, even in the absence of an externally applied stressor (Fee *et al.* 2007; Pastor *et al.* 2008, 2012). Absent EtOH sensitization in CRF<sub>1</sub> mice was also associated with a blunted endocrine response (Pastor *et al.* 2008), suggesting an involvement of the HPA axis. Repeated injections of CORT sensitizes the locomotor-stimulant response to EtOH; however, the doses of systemic CORT necessary to induce sensitization resulted in plasma CORT levels notably higher than those produced by a sensitizing EtOH treatment (Pastor *et al.* 2012). Participation of hypothalamic CRF and CORT, therefore, appears to be necessary, but not sufficient, to explain the role of CRF/CRF<sub>1</sub> in the acquisition of sensitization to EtOH. In addition, the CORT synthesis inhibitor metyrapone prevents the development, but not the expression, of EtOH sensitization (Roberts *et al.* 1995). Furthermore, our data are in agreement with previous findings showing that, although EtOH- or stress-induced changes in CORT can be necessary to mediate acquisition of EtOH sensitization, no direct temporal correlation between plasma CORT levels and behavior has been seen (Pastor *et al.* 2012; Roberts *et al.* 1995). In summary, a CRF-dependent mechanism, via CRF<sub>1</sub>, involving the HPA axis has been proposed for acquisition of sensitization, whereas an extra-hypothalamic CRF/CRF<sub>1</sub> mechanism has been suggested for expression of EtOH sensitization (Pastor *et al.* 2008, 2012).

## Concluding remarks and future perspectives: from preclinical to clinical

The preclinical investigation of CRF receptors and ligands in stress vulnerability, EtOH dependence and relapse is among the most active research areas focused on the pharmacology and genetics of EtOH-induced behavior. This review has summarized evidence for CRF-related biological determinants that mediate stress- and EtOH-induced behavioral changes. Robust scientific evidence suggests that CRF and CRF<sub>1</sub> play seminal roles in stress-induced changes in EtOH consumption, binge-like EtOH intake, post-dependent heightened drinking, genetic predisposition, negative emotionality and anxiety and stress- and EtOH-induced behavioral sensitization. The field would benefit from additional research aimed at identifying the specific molecular determinants of EtOH-induced CRF<sub>1</sub> activation and CRF<sub>1</sub>-mediated neuroplasticity that contributes to changes in EtOH responses. In an elegant study combining pharmacological and KO approaches, Bajo *et al.* (2008) showed that EtOH induces the release of GABA in the CeA via a mechanism that depends on a CRF<sub>1</sub>-initiated mechanism, which requires participation of protein kinase C (PKC) epsilon. Mutant mice lacking PKC epsilon showed a stress- and EtOH-induced phenotypic profile comparable to that found in CRF<sub>1</sub> KO mice (Table 1), characterized by reduced anxiety-like behavior and EtOH consumption (Hodge *et al.* 1999, 2002; Olive *et al.* 2000). Additional research exploring whether this mechanism is also involved in CRF<sub>1</sub>-induced effects in other brain regions would further define the relevant brain circuitry. As recently reviewed by Haass-Koffler and Bartlett (2012), CRF plays an important role in facilitating acquisition and maintenance of plasticity in the VTA and amygdala, particularly via enhanced glutamatergic activation and decreased GABA-mediated inhibition. Further research exploring the mechanisms supporting CRF<sub>1</sub>-mediated plasticity would also be extremely relevant in this field.

Given its clinical relevance and the notion that CRF-mediated neuroplasticity in the mesocorticolimbic neuronal network may contribute to stress vulnerability, loss of control over EtOH consumption and relapse, an increased and particular focus should be placed on exploring strategies to block experiencing the effects of such neuroadaptations. This is sometimes referred to as the *expression* of the neuroadaptive effect. Blocking or reducing the expression of such neuroplastic changes could include not only pharmacological strategies, but also behavioral strategies. Solinas *et al.* (2008) reported that environmental enrichment can reduce some of the neurochemical and behavioral effects of repeated administrations of cocaine, and others have indicated that this type of manipulation can reduce stress levels *per se* and also reduce elevated stress hormones associated with morphine or amphetamine administration (Ravenelle *et al.* 2013; Xu *et al.* 2014). Investigating whether environmental enrichment, such as increased physical exercise (Segat *et al.* 2014), might alter behavioral and neurochemical indicators of CRF-mediated neuroplasticity associated with a history of EtOH administration may be a valuable future line of research. Clearly, preventing all exposure to EtOH is almost impossible, so focusing on the *acquisition* of neuroadaptations may be less fruitful from the perspective of treatment; however, it should be mentioned that recent findings for cocaine suggest that loss of environmental enrichment could increase vulnerability to drug use (Nader *et al.* 2012), and thus increase the probability of drug-induced neuroplasticity.

In view of some recent findings (reviewed by Zorrilla *et al.* 2014), additional preclinical research is needed on genetic factors that contribute to differential effectiveness of CRF<sub>1</sub> antagonists (Heilig *et al.* 2010; Sinha 2008). Further, additional explorations are needed to substantiate data suggesting that gene polymorphisms may play a role in risk for EtOH use. For example, *Crh* and *Crhr1* polymorphisms have been associated with increased active responses to stress in animals selectively bred for high preference for EtOH (Ayanwuyi *et al.* 2013; Cippitelli *et al.* 2014) and with increased EtOH consumption in monkeys exposed to early life stress (Barr *et al.* 2009). Polymorphisms in human *CRH1* and *CRHBP* have also been associated with different aspects of alcohol use and dependence (Chen *et al.* 2010; Enoch *et al.* 2008; Treutlein *et al.* 2006).

Finally, based on promising results for CRF<sub>1</sub> antagonist effects on EtOH consumption in animal models, there has been considerable interest in the potential for these drugs as pharmacotherapeutics for alcohol use disorders. Zorrilla *et al.* (2013) suggest that such drugs have promise, in part, because their anxiolytic-like actions do not appear to be susceptible to tolerance (Zorrilla & Koob 2004), they do not appear to have sedative effects or adverse effects on motor coordination nor adversely affect attention or learning (Hogan *et al.* 2005; Zorrilla & Koob 2004; Zorrilla *et al.* 2002), and they may have little addiction liability (Broadbear *et al.* 2002; Sahuque *et al.* 2006; Stinus *et al.* 2005). Clinical trials began about 10 years ago (December 2004) with several CRF<sub>1</sub> antagonists. Traits being examined have included major depression, irritable bowel syndrome, social anxiety disorder and post-traumatic stress disorder. None appear to have completed a Phase III trial. Development of one antagonist was discontinued due to instances of elevated liver enzymes, others because of lack of efficacy in double-blind, placebo-controlled trials for major depression (Koob & Zorrilla 2012; Zorrilla & Koob 2010). Koob and Zorrilla (2012) have provided the revisionist view that CRF<sub>1</sub> antagonists may be most efficacious for psychiatric disorders in which stress is a more dynamic than chronic factor, including addiction. Perhaps, an alternative to consider is a drug(s) that has indirect effects on the CRF system. For example, in one study, the reduction in EtOH intake by the opioid receptor antagonist, naltrexone, was associated with blockade of CRF expression in the PVN induced by EtOH drinking (Oliva & Manzanares 2007). In another study, the effect of combined naltrexone and the CRF<sub>1</sub> antagonist, CP154526, was examined on intermittent access EtOH drinking in C57BL/6J mice, when infused into the DR. Each drug was effective, at least transiently, when given alone, but an increased effect was not seen when the drugs were given together (Hwa *et al.* 2014). However, this study used an intermittent access EtOH protocol that did not specifically include evaluation of the contribution of cue/context effects, which could be important. Previous data indicate that opioid antagonists not only reduce EtOH intake (Méndez & Morales-Mulia 2008), but also reduce cue-dependent reinstatement of EtOH seeking (Liu & Weiss 2002). Context-dependent EtOH reinstatement has also been seen to be mediated by opioid receptors, in particular, BLA opioid receptors (Burattini *et al.* 2006; Marinelli *et al.* 2010). These pre-clinical data are particularly relevant, as human data indicate that opioid antagonism increases duration of abstinence periods (Maisei *et al.* 2013; O'Malley *et al.* 2007), which might be an indicator of opioid-mediated attenuation of the relapse-triggering strength of context and other conditioned stimuli. A combined strategy that reduces vulnerability to both stress-induced and conditioned stimuli-induced relapse

could be important to consider. Collectively, we agree with many other investigators that the CRF system plays a remarkably important role in the etiology and maintenance of addiction, and particularly in the effects of excessive use. The need for continued research directed at identifying ways to reverse or inhibit the effect of changes in this system on active and relapsing use is supported by the existing findings.

## Acknowledgments

The authors were supported by the Department of Veterans Affairs; NIH NIAAA grants P60AA010760, R24AA020245 and U01AA013519 and NIH NIDA grant P50DA018165, during the writing of this manuscript. The authors have no financial conflict of interest to disclose.

## References

- Adler CM, Elman I, Weisenfeld N, Kestler L, Pickar D, Breier A. Effects of acute metabolic stress on striatal dopamine release in healthy volunteers. *Neuropsychopharmacology*. 2000; 22:545–550. [PubMed: 10731630]
- Aguilar MA, Garcia-Pardo MP, Montagud-Romero S, Minarro J, Do Couto BR. Impact of social stress in addiction to psychostimulants: what we know from animal models. *Curr Pharm Des*. 2013; 19:7009–7025. [PubMed: 23574439]
- Ahima R, Krozowski Z, Harland R. Type I corticosteroid receptor-like immunoreactivity in the rat CNS: distribution and regulation by corticosteroids. *J Comp Neurol*. 1991; 313:522–538. [PubMed: 1770174]
- Alderman SL, Bernier NJ. Localization of corticotropin-releasing factor, urotensin I, and CRF-binding protein gene expression in the brain of the zebrafish, *Danio rerio*. *J Comp Neurol*. 2007; 502:783–793. [PubMed: 17436299]
- Allen CD, Rivier CL, Lee SY. Adolescent alcohol exposure alters the central brain circuits known to regulate the stress response. *Neuroscience*. 2011; 182:162–168. [PubMed: 21382450]
- Armario A. The hypothalamic-pituitary-adrenal axis: what can it tell us about stressors? *CNS Neurol Disord Drug Targets*. 2006; 5:485–501. [PubMed: 17073652]
- Armario A. Activation of the hypothalamic-pituitary-adrenal axis by addictive drugs: different pathways, common outcome. *Trends Pharmacol Sci*. 2010; 31:318–325. [PubMed: 20537734]
- Aubry JM. CRF system and mood disorders. *J Chem Neuroanat*. 2013; 54:20–24. [PubMed: 24060608]
- Ayanwuyi LO, Carvajal F, Lerma-Cabrera JM, Domi E, Bjork K, Ubaldi M, Heilig M, Roberto M, Ciccocioppo R, Cippitelli A. Role of a genetic polymorphism in the corticotropin-releasing factor receptor 1 gene in alcohol drinking and seeking behaviors of Marchigian Sardinian alcohol-preferring rats. *Front Psychiatry*. 2013; 4:23.10.3389/fpsy.2013.00023 [PubMed: 23630503]
- Bajo M, Cruz MT, Siggins GR, Messing R, Roberto M. Protein kinase C epsilon mediation of CRF- and ethanol-induced GABA release in central amygdala. *Proc Natl Acad Sci U S A*. 2008; 105:8410–8415. [PubMed: 18541912]
- Baldwin HA, Rassnick S, Rivier J, Koob GF, Britton KT. CRF antagonist reverses the “anxiogenic” response to ethanol withdrawal in the rat. *Psychopharmacology (Berl)*. 1991; 103:227–232. [PubMed: 2027923]
- Bale TL, Chen A. Minireview: CRF and Wylie Vale: a story of 41 amino acids and a Texan with grit. *Endocrinology*. 2012; 153:2556–2561. [PubMed: 22492308]
- Bale TL, Vale WW. CRF and CRF receptors: role in stress responsivity and other behaviors. *Annu Rev Pharmacol Toxicol*. 2004; 44:525–557. [PubMed: 14744257]
- Barr CS, Dvoskin RL, Yuan Q, Lipsky RH, Gupte M, Hu X, Zhou Z, Schwandt ML, Lindell SG, McKee M, Becker ML, Kling MA, Gold PW, Higley D, Heilig M, Suomi SJ, Goldman D. CRH haplotype as a factor influencing cerebrospinal fluid levels of corticotropin-releasing hormone, hypothalamic-pituitary-adrenal axis activity, temperament, and alcohol consumption in rhesus macaques. *Arch Gen Psychiatry*. 2008; 65:934–944. [PubMed: 18678798]

- Barr CS, Dvoskin RL, Gupte M, Sommer W, Sun H, Schwandt ML, Lindell SG, Kasckow JW, Suomi SJ, Goldman D, Higley JD, Heilig M. Functional CRH variation increases stress-induced alcohol consumption in primates. *Proc Natl Acad Sci U S A*. 2009; 106:14593–14598. [PubMed: 19706546]
- Bell SM, Reynolds JG, Thiele TE, Gan J, Figlewicz DP, Woods SC. Effects of third intracerebroventricular injections of corticotropin-releasing factor (CRF) on ethanol drinking and food intake. *Psychopharmacology (Berl)*. 1998; 139:128–135. [PubMed: 9768550]
- Berridge KC, Kringelbach ML. Neuroscience of affect: brain mechanisms of pleasure and displeasure. *Curr Opin Neurobiol*. 2013; 23:294–303. [PubMed: 23375169]
- Bittencourt JC, Sawchenko PE. Do centrally administered neuropeptides access cognate receptors? An analysis in the central corticotropin-releasing factor system. *J Neurosci*. 2000; 20:1142–1156. [PubMed: 10648719]
- Bittencourt JC, Vaughan J, Arias C, Rissman RA, Vale WW, Sawchenko PE. Urocortin expression in rat brain: evidence against a pervasive relationship of urocortin-containing projections with targets bearing type 2 CRF receptors. *J Comp Neurol*. 1999; 415:285–312. [PubMed: 10553117]
- Boden JM, Fergusson DM. Alcohol and depression. *Addiction*. 2011; 106:906–914. [PubMed: 21382111]
- Bonfiglio JJ, Inda C, Refojo D, Holsboer F, Arzt E, Silberstein S. The corticotropin-releasing hormone network and the hypothalamic-pituitary-adrenal axis: molecular and cellular mechanisms involved. *Neuroendocrinology*. 2011; 94:12–20. [PubMed: 21576930]
- Breese GR, Knapp DJ, Overstreet DH. Stress sensitization of ethanol withdrawal-induced reduction in social interaction: inhibition by CRF-1 and benzodiazepine receptor antagonists and a 5-HT1A-receptor agonist. *Neuropsychopharmacology*. 2004; 29:470–482. [PubMed: 12955093]
- Breese GR, Overstreet DH, Knapp DJ. Conceptual framework for the etiology of alcoholism: a “kindling”/stress hypothesis. *Psychopharmacology (Berl)*. 2005a; 178:367–380. [PubMed: 15765253]
- Breese GR, Overstreet DH, Knapp DJ, Navarro M. Prior multiple ethanol withdrawals enhance stress-induced anxiety-like behavior: inhibition by CRF1- and benzodiazepine-receptor antagonists and a 5-HT1a-receptor agonist. *Neuropsychopharmacology*. 2005b; 30:1662–1669. [PubMed: 15726114]
- Broadbear JH, Winger G, Rice KC, Woods JH. Antalarmin, a putative CRH-R1 antagonist, has transient reinforcing effects in rhesus monkeys. *Psychopharmacology (Berl)*. 2002; 164:268–276. [PubMed: 12424550]
- Brown M. Corticotropin releasing factor: central nervous system sites of action. *Brain Res*. 1986; 399:10–14. [PubMed: 3492236]
- Brujinzeel AW, Small E, Pasek TM, Yamada H. Corticotropin-releasing factor mediates the dysphoria-like state associated with alcohol withdrawal in rats. *Behav Brain Res*. 2010; 210:288–291. [PubMed: 20193713]
- Burattini C, Gill TM, Aicardi G, Janak PH. The ethanol self-administration context as a reinstatement cue: acute effects of naltrexone. *Neuroscience*. 2006; 139:877–887. [PubMed: 16516392]
- Burke AR, Miczek KA. Stress in adolescence and drugs of abuse in rodent models: role of dopamine, CRF, and HPA axis. *Psychopharmacology (Berl)*. 2014; 231:1557–1580. [PubMed: 24370534]
- Cador M, Cole BJ, Koob GF, Stinus L, Le Moal M. Central administration of corticotropin releasing factor induces long-term sensitization to D-amphetamine. *Brain Res*. 1993; 606:181–186. [PubMed: 8490714]
- Cavalcante JC, Sita LV, Mascaro MB, Bittencourt JC, Elias CF. Distribution of urocortin 3 neurons innervating the ventral premammillary nucleus in the rat brain. *Brain Res*. 2006; 1089:116–125. [PubMed: 16638605]
- Chen AC, Manz N, Tang Y, Rangaswamy M, Almasy L, Kuperman S, Nurnberger J Jr, O'Connor SJ, Edenberg HJ, Schuckit MA, Tischfield J, Foroud T, Bierut LJ, Rohrbach J, Rice JP, Goate A, Hesselbrock V, Porjesz B. Single-nucleotide polymorphisms in corticotropin releasing hormone receptor 1 gene (CRHR1) are associated with quantitative trait of event-related potential and alcohol dependence. *Alcohol Clin Exp Res*. 2010; 34:988–996. [PubMed: 20374216]



- Chu K, Koob GF, Cole M, Zorrilla EP, Roberts AJ. Dependence-induced increases in ethanol self-administration in mice are blocked by the CRF1 receptor antagonist antalarmin and by CRF1 receptor knockout. *Pharmacol Biochem Behav.* 2007; 86:813–821. [PubMed: 17482248]
- Ciccocioppo R, Gehlert DR, Ryabinin A, et al. Stress-related neuropeptides and alcoholism: CRH, NPY, and beyond. *Alcohol.* 2009; 43:491–498. [PubMed: 19913192]
- Cippitelli A, Damadzic R, Singley E, Thorsell A, Ciccocioppo R, Eskay RL, Heilig M. Pharmacological blockade of corticotropin-releasing hormone receptor 1 (CRH1R) reduces voluntary consumption of high alcohol concentrations in non-dependent Wistar rats. *Pharmacol Biochem Behav.* 2012; 100:522–529. [PubMed: 22036774]
- Cippitelli A, Ayanwuyi LO, Barbier E, Domi E, Lerma-Cabrera JM, Carvajal F, Scuppa G, Li H, Ubaldi M, Heilig M, Roberto M, Ciccocioppo R. Polymorphism in the corticotropin-releasing factor receptor 1 (CRF1-R) gene plays a role in shaping the high anxious phenotype of Marchigian Sardinian alcohol-preferring (msP) rats. *Psychopharmacology (Berl).* 2014 Epub ahead of print. 10.1007/s00213-014-3743-7
- Clapp P, Bhave SV, Hoffman PL. How adaptation of the brain to alcohol leads to dependence: a pharmacological perspective. *Alcohol Res Health.* 2008; 31:310–339. [PubMed: 20729980]
- Cole BJ, Cador M, Stinus L, Rivier J, Vale W, Koob GF, Le Moal M. Central administration of a CRF antagonist blocks the development of stress-induced behavioral sensitization. *Brain Res.* 1990; 512:343–346. [PubMed: 2354366]
- Coste SC, Kesterson RA, Heldwein KA, Stevens SL, Heard AD, Hollis JH, Murray SE, Hill JK, Pantely GA, Hohimer AR, Hatton DC, Phillips TJ, Finn DA, Low MJ, Rittenberg MB, Stenzel P, Stenzel-Poore MP. Abnormal adaptations to stress and impaired cardiovascular function in mice lacking corticotropin-releasing hormone receptor-2. *Nat Genet.* 2000; 24:403–409. [PubMed: 10742107]
- Coste SC, Heard AD, Phillips TJ, Stenzel-Poore MP. Corticotropin-releasing factor receptor type 2-deficient mice display impaired coping behaviors during stress. *Genes Brain Behav.* 2006; 5:131–138. [PubMed: 16507004]
- Cowen MS, Chen F, Lawrence AJ. Neuropeptides: implications for alcoholism. *J Neurochem.* 2004; 89:273–285. [PubMed: 15056272]
- Crabbe JC, Phillips TJ, Harris RA, Arends MA, Koob GF. Alcohol-related genes: contributions from studies with genetically engineered mice. *Addict Biol.* 2006; 11:195–269. [PubMed: 16961758]
- Criado JR, Liu T, Ehlers CL, Mathe AA. Prolonged chronic ethanol exposure alters neuropeptide Y and corticotropin-releasing factor levels in the brain of adult Wistar rats. *Pharmacol Biochem Behav.* 2011; 99:104–111. [PubMed: 21527271]
- Dave JR, Eiden LE, Karanian JW, Eskay RL. Ethanol exposure decreases pituitary corticotropin-releasing factor binding, adenylate cyclase activity, proopiomelanocortin biosynthesis, and plasma beta-endorphin levels in the rat. *Endocrinology.* 1986; 118:280–286. [PubMed: 2934242]
- De Souza EB. Corticotropin-releasing factor receptors: physiology, pharmacology, biochemistry and role in central nervous system and immune disorders. *Psychoneuroendocrinology.* 1995; 20:789–819. [PubMed: 8834089]
- Deussing JM, Breu J, Kühne C, Kallnik M, Bunck M, Glasl L, Yen YC, Schmidt MV, Zurmühlen R, Vogl AM, Gailus-Durner V, Fuchs H, Holter SM, Wotjak CT, Landgraf R, de Angelis MH, Holsboer F, Würst W. Urocortin 3 modulates social discrimination abilities via corticotropin-releasing hormone receptor type 2. *J Neurosci.* 2010; 30:9103–9116. [PubMed: 20610744]
- Dhaher R, Finn D, Snelling C, Hitzemann R. Lesions of the extended amygdala in C57BL/6J mice do not block the intermittent ethanol vapor-induced increase in ethanol consumption. *Alcohol Clin Exp Res.* 2008; 32:197–208. [PubMed: 18162080]
- Duvarci S, Pare D. Amygdala microcircuits controlling learned fear. *Neuron.* 2014; 82:966–980. [PubMed: 24908482]
- Egli M. Can experimental paradigms and animal models be used to discover clinically effective medications for alcoholism? *Addict Biol.* 2005; 10:309–319. [PubMed: 16318951]
- Ehlers CL, Chaplin RI, Wall TL, Lumeng L, Li TK, Owens MJ, Nemeroff CB. Corticotropin releasing factor (CRF): studies in alcohol preferring and non-preferring rats. *Psychopharmacology (Berl).* 1992; 106:359–364.



- Enoch MA, Shen PH, Ducci F, Yuan Q, Liu J, White KV, Albaugh B, Hodgkinson CA, Goldman D. Common genetic origins for EEG, alcoholism and anxiety: the role of CRH-BP. *PLoS One*. 2008; 3:e3620.10.1371/journal.pone.0003620 [PubMed: 18974851]
- Errico AL, Parsons OA, King AC, Lovallo WR. Attenuated cortisol response to biobehavioral stressors in sober alcoholics. *Alcohol*. 1993; 54:393–398.
- Fahlke C, Hard E, Hansen S. Facilitation of ethanol consumption by intracerebroventricular infusions of corticosterone. *Psychopharmacology (Berl)*. 1996; 127:133–139. [PubMed: 8888379]
- Falco AM, Bergstrom HC, Bachus SE, Smith RF. Persisting changes in basolateral amygdala mRNAs after chronic ethanol consumption. *Physiol Behav*. 2009; 96:169–173. [PubMed: 18938187]
- Fee JR, Sparta DR, Picker MJ, Thiele TE. Corticotropin releasing factor-1 receptor antagonist, CP-154,526, blocks the expression of ethanol-induced behavioral sensitization in DBA/2J mice. *Neuroscience*. 2007; 150:14–21. [PubMed: 17919825]
- File SE. The use of social interaction as a method for detecting anxiolytic activity of chlordiazepoxide-like drugs. *J Neurosci Methods*. 1980; 2:219–238. [PubMed: 6120260]
- Finn DA, Snelling C, Fretwell AM, Tanchuck MA, Underwood L, Cole M, Crabbe JC, Roberts AJ. Increased drinking during withdrawal from intermittent ethanol exposure is blocked by the CRF receptor antagonist D-Phe-CRF(12-41). *Alcohol Clin Exp Res*. 2007; 31:939–949. [PubMed: 17403068]
- Fonareva I, Spangler E, Cannella N, Sabino V, Cottone P, Ciccocioppo R, Zorrilla EP, Ryabinin AE. Increased periculomotor urocortin 1 immunoreactivity in genetically selected alcohol preferring rats. *Alcohol Clin Exp Res*. 2009; 33:1956–1965. [PubMed: 19673740]
- Funk CK, Koob GF. A CRF(2) agonist administered into the central nucleus of the amygdala decreases ethanol self-administration in ethanol-dependent rats. *Brain Res*. 2007; 1155:172–178. [PubMed: 17512918]
- Funk CK, O'Dell LE, Crawford EF, Koob GF. Corticotropin-releasing factor within the central nucleus of the amygdala mediates enhanced ethanol self-administration in withdrawn, ethanol-dependent rats. *J Neurosci*. 2006; 26:11324–11332. [PubMed: 17079660]
- Funk CK, Zorrilla EP, Lee MJ, Rice KC, Koob GF. Corticotropin-releasing factor 1 antagonists selectively reduce ethanol self-administration in ethanol-dependent rats. *Biol Psychiatry*. 2007; 61:78–86. [PubMed: 16876134]
- Gabriel KI, Yu CL, Osborn JA, Weinberg J. Prenatal ethanol exposure alters sensitivity to the effects of corticotropin-releasing factor (CRF) on behavior in the elevated plusmaze. *Psychoneuroendocrinology*. 2006; 31:1046–1056. [PubMed: 16934947]
- Gehlert DR, Cippitelli A, Thorsell A, Le AD, Hipskind PA, Hamdouchi C, Lu J, Hembre EJ, Cramer J, Song M, McKinzie D, Morin M, Ciccocioppo R, Heilig M. 3-(4-Chloro-2-morpholin-4-yl-thiazol-5-yl)-8-(1-ethylpropyl)-2,6-dimethyl-imidazo [1,2-b]pyridazine: a novel brain-penetrant, orally available corticotropin-releasing factor receptor 1 antagonist with efficacy in animal models of alcoholism. *J Neurosci*. 2007; 27:2718–2726. [PubMed: 17344409]
- George O, Koob GF. Individual differences in prefrontal cortex function and the transition from drug use to drug dependence. *Neurosci Biobehav Rev*. 2010; 35:232–247. [PubMed: 20493211]
- George SR, Fan T, Roldan L, Naranjo CA. Corticotropin-releasing factor is altered in brains of animals with high preference for ethanol. *Alcohol Clin Exp Res*. 1990; 14:425–429. [PubMed: 2378427]
- Gerra G, Somaini L, Manfredini M, Raggi MA, Saracino MA, Amore M, Leonardi C, Cortese E, Donnini C. Dysregulated responses to emotions among abstinent heroin users: correlation with childhood neglect and addiction severity. *Prog Neuropsychopharmacol Biol Psychiatry*. 2014; 48:220–228. [PubMed: 24161666]
- Giardino WJ, Ryabinin AE. CRF1 receptor signaling regulates food and fluid intake in the drinking-in-the-dark model of binge alcohol consumption. *Alcohol Clin Exp Res*. 2013; 37:1161–1170. [PubMed: 23398267]
- Giardino WJ, Cocking DL, Kaur S, Cunningham CL, Ryabinin AE. Urocortin-1 within the centrally-projecting Edinger-Westphal nucleus is critical for ethanol preference. *PLoS One*. 2011; 6:e26997.10.1371/journal.pone.0026997 [PubMed: 22046429]

- Gilpin NW. Corticotropin-releasing factor (CRF) and neuropeptide Y (NPY): effects on inhibitory transmission in central amygdala, and anxiety- & alcohol-related behaviors. *Alcohol*. 2012; 46:329–337. [PubMed: 22560367]
- Gilpin NW. Brain reward and stress systems in addiction. *Front Psychiatry*. 2014; 5:79. [PubMed: 25071611]
- Gilpin NW, Richardson HN, Koob GF. Effects of CRF1-receptor and opioid-receptor antagonists on dependence-induced increases in alcohol drinking by alcohol-preferring (P) rats. *Alcohol Clin Exp Res*. 2008; 32:1535–1542. [PubMed: 18631323]
- Gilpin NW, Karanikas CA, Richardson HN. Adolescent binge drinking leads to changes in alcohol drinking, anxiety, and amygdalar corticotropin releasing factor cells in adulthood in male rats. *PLoS One*. 2012; 7:e31466.10.1371/journal.pone.0031466 [PubMed: 22347484]
- Gray TS, Magnuson DJ. Peptide immunoreactive neurons in the amygdala and the bed nucleus of the stria terminalis project to the midbrain central gray in the rat. *Peptides*. 1992; 13:451–460. [PubMed: 1381826]
- Griffin WC III. Alcohol dependence and free-choice drinking in mice. *Alcohol*. 2014; 48:287–293. [PubMed: 24530006]
- Haass-Koffler CL, Bartlett SE. Stress and addiction: contribution of the corticotropin releasing factor (CRF) system in neuroplasticity. *Front Mol Neurosci*. 2012; 5:91.10.3389/fnmol.2012.00091 [PubMed: 22973190]
- Haass-Koffler CL, Leggio L, Kenna GA. Pharmacological approaches to reducing craving in patients with alcohol use disorders. *CNS Drugs*. 2014; 28:343–360. [PubMed: 24573997]
- Handa RJ, Weiser MJ. Gonadal steroid hormones and the hypothalamo-pituitary-adrenal axis. *Front Neuroendocrinol*. 2014; 35:197–220. [PubMed: 24246855]
- Hansson AC, Cippitelli A, Sommer WH, Fedeli A, Bjork K, Soverchia L, Terasmaa A, Massi M, Heilig M, Ciccocioppo R. Variation at the rat *Crrh1* locus and sensitivity to relapse into alcohol seeking induced by environmental stress. *Proc Natl Acad Sci U S A*. 2006; 103:15236–15241. [PubMed: 17015825]
- Hansson AC, Cippitelli A, Sommer WH, Ciccocioppo R, Heilig M. Region-specific down-regulation of *Crrh1* gene expression in alcohol-preferring msP rats following ad lib access to alcohol. *Addict Biol*. 2007; 12:30–34. [PubMed: 17407495]
- Hauger RL, Risbrough V, Brauns O, Dautzenberg FM. Corticotropin releasing factor (CRF) receptor signaling in the central nervous system: new molecular targets. *CNS Neurol Disord Drug Targets*. 2006; 5:453–479. [PubMed: 16918397]
- Hayes DM, Knapp DJ, Breese GR, Thiele TE. Comparison of basal neuropeptide Y and corticotropin releasing factor levels between the high ethanol drinking C57BL/6J and low ethanol drinking DBA/2J inbred mouse strains. *Alcohol Clin Exp Res*. 2005; 29:721–729. [PubMed: 15897715]
- Heilig M, Egli M. Pharmacological treatment of alcohol dependence: target symptoms and target mechanisms. *Pharmacol Ther*. 2006; 111:855–876. [PubMed: 16545872]
- Heilig M, Koob GF. A key role for corticotropin-releasing factor in alcohol dependence. *Trends Neurosci*. 2007; 30:399–406. [PubMed: 17629579]
- Heilig M, Thorsell A, Sommer WH, Hansson AC, Ramchandani VA, George DT, Hommer D, Barr CS. Translating the neuroscience of alcoholism into clinical treatments: from blocking the buzz to curing the blues. *Neurosci Biobehav Rev*. 2010; 35:334–344. [PubMed: 19941895]
- Herman JP, Figueiredo H, Mueller NK, Ulrich-Lai Y, Ostrander MM, Choi DC, Cullinan WE. Central mechanisms of stress integration: hierarchical circuitry controlling hypothalamo-pituitary-adrenocortical responsiveness. *Front Neuroendocrinol*. 2003; 24:151–180. [PubMed: 14596810]
- Hodge CW, Mehmert KK, Kelley SP, McMahan T, Haywood A, Olive MF, Wang D, Sanchez-Perez AM, Messing RO. Supersensitivity to allosteric GABA(A) receptor modulators and alcohol in mice lacking PKC epsilon. *Nat Neurosci*. 1999; 2:997–1002. [PubMed: 10526339]
- Hodge CW, Raber J, McMahan T, Walter H, Sanchez-Perez AM, Olive MF, Mehmert K, Morrow AL, Messing RO. Decreased anxiety-like behavior, reduced stress hormones, and neurosteroid supersensitivity in mice lacking protein kinase C epsilon. *J Clin Invest*. 2002; 110:1003–1010. [PubMed: 12370278]

- Hogan JB, Hodges DB Jr, Lelas S, Gilligan PJ, McElroy JF, Lindner MD. Effects of CRF1 receptor antagonists and benzodiazepines in the Morris water maze and delayed non-matching to position tests. *Psychopharmacology (Berl)*. 2005; 178:410–419. [PubMed: 15765256]
- Hostetler CM, Ryabinin AE. The CRF system and social behavior: a review. *Front Neurosci*. 2013; 7:92.10.3389/fnins.2013.00092 [PubMed: 23754975]
- Huang MM, Overstreet DH, Knapp DJ, Angel R, Wills TA, Navarro M, Rivier J, Vale W, Breese GR. Corticotropin-releasing factor (CRF) sensitization of ethanol withdrawal-induced anxiety-like behavior is brain site specific and mediated by CRF-1 receptors: relation to stress-induced sensitization. *J Pharmacol Exp Ther*. 2010; 332:298–307. [PubMed: 19843974]
- Huising MO, Vaughan JM, Shah SH, Grillot KL, Donaldson CJ, Rivier J, Flik G, Vale WW. Residues of corticotropin releasing factor-binding protein (CRF-BP) that selectively abrogate binding to CRF but not urocortin 1. *J Biol Chem*. 2008; 283:8902–8912. [PubMed: 18234674]
- Hwa LS, Debold JF, Miczek KA. Alcohol in excess: CRF(1) receptors in the rat and mouse VTA and DRN. *Psychopharmacology (Berl)*. 2013; 225:313–327. [PubMed: 22885872]
- Hwa LS, Shimamoto A, Kayyali T, Norman KJ, Valentino RJ, DeBold JF, Miczek KA. Dissociation of  $\mu$ -opioid receptor and CRF-R1 antagonist effects on escalated ethanol consumption and mPFC serotonin in C57BL/6J mice. *Addict Biol*. 2014 Epub ahead of print. 10.1111/adb.12189
- Hwang BH, Stewart R, Zhang JK, Lumeng L, Li TK. Corticotropin-releasing factor gene expression is down-regulated in the central nucleus of the amygdala of alcohol-preferring rats which exhibit high anxiety: a comparison between rat lines selectively bred for high and low alcohol preference. *Brain Res*. 2004; 1026:143–150. [PubMed: 15476706]
- Janssen D, Kozicz T. Is it really a matter of simple dualism? Corticotropin-releasing factor receptors in body and mental health. *Front Endocrinol (Lausanne)*. 2013; 4:28.10.3389/fendo.2013.00028 [PubMed: 23487366]
- Jee C, Lee J, Lim JP, Parry D, Messing RO, McIntire SL. SEB-3, a CRF receptor-like GPCR, regulates locomotor activity states, stress responses and ethanol tolerance in *Caenorhabditis elegans*. *Genes Brain Behav*. 2013; 12:250–262. [PubMed: 22853648]
- Jenkins JS, Connolly J. Adrenocortical response to ethanol in man. *Br Med J*. 1968; 2:804–805. [PubMed: 5656299]
- Ji D, Gilpin NW, Richardson HN, Rivier CL, Koob GF. Effects of naltrexone, duloxetine, and a corticotropin-releasing factor type 1 receptor antagonist on binge-like alcohol drinking in rats. *Behav Pharmacol*. 2008; 19:1–12.
- Justice NJ, Yuan ZF, Sawchenko PE, Vale W. Type 1 corticotropin-releasing factor receptor expression reported in BAC transgenic mice: implications for reconciling ligand-receptor mismatch in the central corticotropin-releasing factor system. *J Comp Neurol*. 2008; 511:479–496. [PubMed: 18853426]
- Kaur S, Li J, Stenzel-Poore MP, Ryabinin AE. Corticotropin-releasing factor acting on corticotropin-releasing factor receptor type 1 is critical for binge alcohol drinking in mice. *Alcohol Clin Exp Res*. 2012; 36:369–376. [PubMed: 21895713]
- Kirkman S, Nelson DH. Alcohol-induced pseudo-Cushing's disease: a study of prevalence with review of the literature. *Metabolism*. 1988; 37:390–394. [PubMed: 2833680]
- de Kloet ER. Lifetime achievement from a brain-adrenal perspective: on the CRF-urocortin-glucocorticoid balance. *J Chem Neuroanat*. 2013; 54:42–49. [PubMed: 24161414]
- Knapp DJ, Overstreet DH, Moy SS, Breese GR. SB242084, flumazenil, and CRA1000 block ethanol withdrawal-induced anxiety in rats. *Alcohol*. 2004; 32:101–111. [PubMed: 15163561]
- Knapp DJ, Overstreet DH, Huang M, Wills TA, Whitman BA, Angel RA, Sinnett SE, Breese GR. Effects of a stressor and corticotrophin releasing factor on ethanol deprivation-induced ethanol intake and anxiety-like behavior in alcohol-preferring P rats. *Psychopharmacology (Berl)*. 2011a; 218:179–189. [PubMed: 21643675]
- Knapp DJ, Whitman BA, Wills TA, Angel RA, Overstreet DH, Criswell HE, Ming Z, Breese GR. Cytokine involvement in stress may depend on corticotrophin releasing factor to sensitize ethanol withdrawal anxiety. *Brain Behav Immun*. 2011b; 25(Suppl. 1):S146–S154. [PubMed: 21377524]
- Koenig HN, Olive F. The glucocorticoid receptor antagonist mifepristone reduces ethanol intake in rats under limited access conditions. *Psychoneuroendocrinology*. 2004; 29:999–1003.

- Koob GF. The role of CRF and CRF-related peptides in the dark side of addiction. *Brain Res.* 2010; 1314:3–14. [PubMed: 19912996]
- Koob GF. Addiction is a reward deficit and stress surfeit disorder. *Front Psychiatry.* 2013; 4:72.10.3389/fpsy.2013.00072 [PubMed: 23914176]
- Koob GF. Neurocircuitry of alcohol addiction: synthesis from animal models. *Handb Clin Neurol.* 2014; 125:33–54. [PubMed: 25307567]
- Koob G, Kreek MJ. Stress, dysregulation of drug reward pathways, and the transition to drug dependence. *Am J Psychiatry.* 2007; 164:1149–1159. [PubMed: 17671276]
- Koob GF, Le Moal M. Drug addiction, dysregulation of reward, and allostasis. *Neuropsychopharmacology.* 2001; 24:97–129. [PubMed: 11120394]
- Koob GF, Le Moal M. Review. Neurobiological mechanisms for opponent motivational processes in addiction. *Philos Trans R Soc Lond B Biol Sci.* 2008; 363:3113–3123. [PubMed: 18653439]
- Koob GF, Zorrilla EP. Neurobiological mechanisms of addiction: focus on corticotropin-releasing factor. *Curr Opin Investig Drugs.* 2010; 11:63–71.
- Koob GF, Zorrilla EP. Update on corticotropin-releasing factor pharmacotherapy for psychiatric disorders: a revisionist view. *Neuropsychopharmacology.* 2012; 37:308–309. [PubMed: 22157874]
- Koob GF, Buck CL, Cohen A, Edwards S, Park PE, Schlosburg JE, Schmeichel B, Vendruscolo LF, Wade CL, Whitfield TW Jr, George O. Addiction as a stress surfeit disorder. *Neuropharmacology.* 2014; 76:370–382. [PubMed: 23747571]
- Kormos V, Gaszner B. Role of neuropeptides in anxiety, stress, and depression: from animals to humans. *Neuropeptides.* 2013; 47:401–419. [PubMed: 24210138]
- Korosi A, Veening JG, Kozicz T, Henckens M, Dederen J, Groenink L, van der Gugten J, Olivier B, Roubos EW. Distribution and expression of CRF receptor 1 and 2 mRNAs in the CRF over-expressing mouse brain. *Brain Res.* 2006; 1072:46–54. [PubMed: 16423327]
- Korosi A, Kozicz T, Richter J, Veening JG, Olivier B, Roubos EW. Corticotropin-releasing factor, urocortin 1, and their receptors in the mouse spinal cord. *J Comp Neurol.* 2007; 502:973–989. [PubMed: 17444496]
- Kozicz T, Bittencourt JC, May PJ, Reiner A, Gamlin PD, Palkovits M, Horn AK, Toledo CA, Ryabinin AE. The Edinger-Westphal nucleus: a historical, structural, and functional perspective on a dichotomous terminology. *J Comp Neurol.* 2011; 519:1413–1434. [PubMed: 21452224]
- Kozicz T, Yanaihara H, Arimura A. Distribution of urocortin-like immunoreactivity in the central nervous system of the rat. *J Comp Neurol.* 1998; 391:1–10. [PubMed: 9527535]
- Kühne C, Puk O, Graw J, Hrabe de Angelis M, Schutz G, Wurst W, Deussing JM. Visualizing corticotropin-releasing hormone receptor type 1 expression and neuronal connectivities in the mouse using a novel multifunctional allele. *J Comp Neurol.* 2012; 520:3150–3180. [PubMed: 22886732]
- Läck AK, Floyd DW, McCool BA. Chronic ethanol ingestion modulates proanxiety factors expressed in rat central amygdala. *Alcohol.* 2005; 36:83–90. [PubMed: 16396741]
- Le AD, Harding S, Juzytsch W, Watchus J, Shalev U, Shaham Y. The role of corticotropin-releasing factor in stress-induced relapse to alcohol-seeking behavior in rats. *Psychopharmacology (Berl).* 2000; 150:317–324. [PubMed: 10923760]
- Le AD, Harding S, Juzytsch W, Fletcher PJ, Shaham Y. The role of corticotropin-releasing factor in the median raphe nucleus in relapse to alcohol. *J Neurosci.* 2002; 22:7844–7849. [PubMed: 12223536]
- Le AD, Funk D, Coen K, Li Z, Shaham Y. Role of corticotropin-releasing factor in the median raphe nucleus in yohimbine-induced reinstatement of alcohol seeking in rats. *Addict Biol.* 2013; 18:448–451. [PubMed: 21967606]
- Lee S, Rivier C. An initial, three-day-long treatment with alcohol induces a long-lasting phenomenon of selective tolerance in the activity of the rat hypothalamic-pituitary-adrenal axis. *J Neurosci.* 1997; 17:8856–8866. [PubMed: 9348353]
- Lee S, Schmidt D, Tilders F, Cole M, Smith A, Rivier C. Prolonged exposure to intermittent alcohol vapors blunts hypothalamic responsiveness to immune and non-immune signals. *Alcohol Clin Exp Res.* 2000; 24:110–122. [PubMed: 10656200]

- Lee S, Schmidt D, Tilders F, Cole M, Smith A, Rivier C. Effect of repeated exposure to alcohol on the response of the hypothalamic-pituitary-adrenal axis of the rat: I. Role of changes in hypothalamic neuronal activity. *Alcohol Clin Exp Res*. 2001a; 25:98–105. [PubMed: 11198721]
- Lee S, Smith GW, Vale W, Lee KF, Rivier C. Mice that lack corticotropin-releasing factor (CRF) receptors type 1 show a blunted ACTH response to acute alcohol despite up-regulated constitutive hypothalamic CRF gene expression. *Alcohol Clin Exp Res*. 2001b; 25:427–433. [PubMed: 11290855]
- Lee S, Selvage D, Hansen K, Rivier C. Site of action of acute alcohol administration in stimulating the rat hypothalamic-pituitary-adrenal axis: comparison between the effect of systemic and intracerebroventricular injection of this drug on pituitary and hypothalamic responses. *Endocrinology*. 2004; 145:4470–4479. [PubMed: 15205375]
- Leggio L, Cardone S, Ferrulli A, Kenna GA, Diana M, Swift RM, Addolorato G. Turning the clock ahead: potential preclinical and clinical neuropharmacological targets for alcohol dependence. *Curr Pharm Des*. 2010; 16:2159–3018. [PubMed: 20482506]
- Lemos JC, Wanat MJ, Smith JS, Reyes BA, Hollon NG, Van Bockstaele EJ, Chavkin C, Phillips PE. Severe stress switches CRF action in the nucleus accumbens from appetitive to aversive. *Nature*. 2012; 490:402–406. [PubMed: 22992525]
- Lewis K, Li C, Perrin MH, Blount A, Kunitake K, Donaldson C, Vaughan J, Reyes TM, Gulyas J, Fischer W, Bilezikjian L, Rivier J, Sawchenko PE, Vale WW. Identification of urocortin III, an additional member of the corticotropin-releasing factor (CRF) family with high affinity for the CRF2 receptor. *Proc Natl Acad Sci U S A*. 2001; 98:7570–7575. [PubMed: 11416224]
- Leyton M, Vezina P. Dopamine ups and downs in vulnerability to addictions: a neurodevelopmental model. *Trends Pharmacol Sci*. 2014; 35:268–276. [PubMed: 24794705]
- Li C, Vaughan J, Sawchenko PE, Vale WW. Urocortin III-immunoreactive projections in rat brain: partial overlap with sites of type 2 corticotrophin-releasing factor receptor expression. *J Neurosci*. 2002; 22:991–1001. [PubMed: 11826127]
- Lijffijt M, Hu K, Swann AC. Stress modulates illness-course of substance use disorders: a translational review. *Front Psychiatry*. 2014; 5:83.10.3389/fpsy.2014.00083 [PubMed: 25101007]
- Liu X, Weiss F. Additive effect of stress and drug cues on reinstatement of ethanol seeking: exacerbation by history of dependence and role of concurrent activation of corticotropin-releasing factor and opioid mechanisms. *J Neurosci*. 2002; 22:7856–7861. [PubMed: 12223538]
- Lodge DJ, Lawrence AJ. The CRF1 receptor antagonist antalarmin reduces volitional ethanol consumption in isolation-reared fawn-hooded rats. *Neuroscience*. 2003; 117:243–247. [PubMed: 12614667]
- Logrip ML, Rivier C, Lau C, Im S, Vaughan J, Lee S. Adolescent alcohol exposure alters the rat adult hypothalamic-pituitary-adrenal axis responsiveness in a sex-specific manner. *Neuroscience*. 2013; 235:174–186. [PubMed: 23337533]
- Lowery EG, Thiele TE. Pre-clinical evidence that corticotropin-releasing factor (CRF) receptor antagonists are promising targets for pharmacological treatment of alcoholism. *CNS Neurol Disord Drug Targets*. 2010; 9:77–86. [PubMed: 20201818]
- Lowery EG, Sparrow AM, Breese GR, Knapp DJ, Thiele TE. The CRF-1 receptor antagonist, CP-154,526, attenuates stress-induced increases in ethanol consumption by BALB/cJ mice. *Alcohol Clin Exp Res*. 2008; 32:240–248. [PubMed: 18162074]
- Lowery EG, Spanos M, Navarro M, Lyons AM, Hodge CW, Thiele TE. CRF-1 antagonist and CRF-2 agonist decrease binge-like ethanol drinking in C57BL/6J mice independent of the HPA axis. *Neuropsychopharmacology*. 2010; 35:1241–1252. [PubMed: 20130533]
- Lowery-Gionta EG, Navarro M, Li C, Pleil KE, Rinker JA, Cox BR, Sprow GM, Kash TL, Thiele TE. Corticotropin releasing factor signaling in the central amygdala is recruited during binge-like ethanol consumption in C57BL/6J mice. *J Neurosci*. 2012; 32:3405–3413. [PubMed: 22399763]
- Lu YL, Richardson HN. Alcohol, stress hormones, and the prefrontal cortex: a proposed pathway to the dark side of addiction. *Neuroscience*. 2014; 277:139–151. [PubMed: 24998895]
- Lukkes JL, Staub DR, Dietrich A, Truitt W, Neufeld-Cohen A, Chen A, Johnson PL, Shekhar A, Lowry CA. Topographical distribution of corticotropin-releasing factor type 2 receptor-like



- immunoreactivity in the rat dorsal raphe nucleus: co-localization with tryptophan hydroxylase. *Neuroscience*. 2011; 183:47–63. [PubMed: 21453754]
- Maisel NC, Blodgett JC, Wilbourne PL, Humphreys K, Finney JW. Meta-analysis of naltrexone and acamprosate for treating alcohol use disorders: when are these medications most helpful? *Addiction*. 2013; 108:275–293. [PubMed: 23075288]
- Manuel R, Metz JR, Flik G, Vale WW, Huising MO. Corticotropin-releasing factor-binding protein (CRF-BP) inhibits CRF- and urotensin-I-mediated activation of CRF receptor-1 and -2 in common carp. *Gen Comp Endocrinol*. 2014; 202:69–75. [PubMed: 24769042]
- Marchant NJ, Kaganovsky K, Shaham Y, Booert JM. Role of corticostriatal circuits in context-induced reinstatement of drug seeking. *Brain Res*. 2014 Epub ahead of print. 10.1016/j.brainres.2014.09.004
- Marinelli PW, Funk D, Juzysch W, Harding S, Rice KC, Sha-ham Y, Le AD. The CRF1 receptor antagonist antalarmin attenuates yohimbine-induced increases in operant alcohol self-administration and reinstatement of alcohol seeking in rats. *Psychopharmacology (Berl)*. 2007; 195:345–355. [PubMed: 17705061]
- Marinelli PW, Funk D, Juzysch W, Le AD. Opioid receptors in the basolateral amygdala but not dorsal hippocampus mediate context-induced alcohol seeking. *Behav Brain Res*. 2010; 211:58–63. [PubMed: 20214927]
- Martin-Fardon R, Zorrilla EP, Ciccocioppo R, Weiss F. Role of innate and drug-induced dysregulation of brain stress and arousal systems in addiction: Focus on corticotropin-releasing factor, nociceptin/orphanin FQ, and orexin/hypocretin. *Brain Res*. 2010; 1314:145–161. [PubMed: 20026088]
- McReynolds JR, Pena DF, Blacktop JM, Mantsch JR. Neurobiological mechanisms underlying relapse to cocaine use: contributions of CRF and noradrenergic systems and regulation by glucocorticoids. *Stress*. 2014; 17:22–38. [PubMed: 24328808]
- Meloni EG, Reedy CL, Cohen BM, Carlezon WA Jr. Activation of raphe efferents to the medial prefrontal cortex by corticotropin-releasing factor: correlation with anxiety-like behavior. *Biol Psychiatry*. 2008; 63:832–839. [PubMed: 18061145]
- Méndez M, Morales-Mulia M. Role of mu and delta opioid receptors in alcohol drinking behaviour. *Curr Drug Abuse Rev*. 2008; 1:239–252. [PubMed: 19630722]
- Merchenthaler I, Vigh S, Petrusz P, Schally AV. Immunocytochemical localization of corticotropin-releasing factor (CRF) in the rat brain. *Am J Anat*. 1982; 165:385–396. [PubMed: 6760710]
- Merchenthaler I, Vigh S, Schally AV, Stumpf WE, Arimura A. Immunocytochemical localization of corticotropin-releasing factor (CRF)-like immunoreactivity in the thalamus of the rat. *Brain Res*. 1984; 323:119–122. [PubMed: 6151862]
- Molander A, Vengeliene V, Heilig M, Wurst W, Deussing JM, Spanagel R. Brain-specific inactivation of the *Crhrl* gene inhibits post-dependent and stress-induced alcohol intake, but does not affect relapse-like drinking. *Neuropsychopharmacology*. 2012; 37:1047–1056. [PubMed: 22113086]
- Morin SM, Ling N, Liu XJ, Kahl SD, Gehlert DR. Differential distribution of urocortin- and corticotropin-releasing factor-like immunoreactivities in the rat brain. *Neuroscience*. 1999; 92:281–291. [PubMed: 10392850]
- Müller MB, Zimmermann S, Sillaber I, Hagemeyer TP, Deussing JM, Timpl P, Kormann MS, Droste SK, Kuhn R, Reul JM, Holsboer F, Wurst W. Limbic corticotropin-releasing hormone receptor 1 mediates anxiety-related behavior and hormonal adaptation to stress. *Nat Neurosci*. 2003; 6:1100–1107. [PubMed: 12973355]
- Myers B, McKlveen JM, Herman JP. Glucocorticoid actions on synapses, circuits, and behavior: implications for the energetics of stress. *Front Neuroendocrinol*. 2014; 35:180–196. [PubMed: 24361584]
- Nader J, Chauvet C, Rawas RE, Favot L, Jaber M, Thiriet N, Solinas M. Loss of environmental enrichment increases vulnerability to cocaine addiction. *Neuropsychopharmacology*. 2012; 37:1579–1587. [PubMed: 22334125]
- Nie Z, Schweitzer P, Roberts AJ, Madamba SG, Moore SD, Siggins GR. Ethanol augments GABAergic transmission in the central amygdala via CRF1 receptors. *Science*. 2004; 303:1512–1514. [PubMed: 15001778]



- O'Callaghan MJ, Croft AP, Jacquot C, Little HJ. The hypothalamopituitary-adrenal axis and alcohol preference. *Brain Res Bull.* 2005; 68:171–178. [PubMed: 16325017]
- Ogilvie KM, Lee S, Rivier C. Divergence in the expression of molecular markers of neuronal activation in the parvocellular paraventricular nucleus of the hypothalamus evoked by alcohol administration via different routes. *J Neurosci.* 1998; 18:4344–4352. [PubMed: 9592111]
- Oliva JM, Manzanares J. Gene transcription alterations associated with decrease of ethanol intake induced by naltrexone in the brain of Wistar rats. *Neuropsychopharmacology.* 2007; 32:1358–1369. [PubMed: 17063152]
- Olive MF, Mehmert KK, Messing RO, Hodge CW. Reduced operant ethanol self-administration and in vivo mesolimbic dopamine responses to ethanol in PKC epsilon-deficient mice. *Eur J Neurosci.* 2000; 12:4131–4140. [PubMed: 11069609]
- Olive MF, Mehmert KK, Koenig HN, Camarini R, Kim JA, Nannini MA, Ou CJ, Hodge CW. A role for corticotropin releasing factor (CRF) in ethanol consumption, sensitivity, and reward as revealed by CRF-deficient mice. *Psychopharmacology (Berl).* 2003; 165:181–187. [PubMed: 12397512]
- O'Malley SS, Garbutt JC, Gastfriend DR, Dong Q, Kranzler HR. Efficacy of extended-release naltrexone in alcohol-dependent patients who are abstinent before treatment. *J Clin Psychopharmacol.* 2007; 27:507–512. [PubMed: 17873686]
- Overstreet DH, Knapp DJ, Breese GR. Modulation of multiple ethanol withdrawal-induced anxiety-like behavior by CRF and CRF1 receptors. *Pharmacol Biochem Behav.* 2004; 77:405–413. [PubMed: 14751471]
- Overstreet DH, Knapp DJ, Breese GR. Pharmacological modulation of repeated ethanol withdrawal-induced anxiety-like behavior differs in alcohol-preferring P and Sprague–Dawley rats. *Pharmacol Biochem Behav.* 2005; 81:122–130. [PubMed: 15894069]
- Overstreet DH, Knapp DJ, Breese GR. Drug challenges reveal differences in mediation of stress facilitation of voluntary alcohol drinking and withdrawal-induced anxiety in alcohol-preferring P rats. *Alcohol Clin Exp Res.* 2007; 31:1473–1481. [PubMed: 17624999]
- Palchadhuri MR, Hauger RL, Wille S, Fuchs E, Dautzenberg FM. Isolation and pharmacological characterization of two functional splice variants of corticotropin-releasing factor type 2 receptor from *Tupaia belangeri*. *J Neuroendocrinol.* 1999; 11:419–428. [PubMed: 10336722]
- Palmer AA, Sharpe AL, Burkhart-Kasch S, McKinnon CS, Coste SC, Stenzel-Poore MP, Phillips TJ. Corticotropin-releasing factor overexpression decreases ethanol drinking and increases sensitivity to the sedative effects of ethanol. *Psychopharmacology (Berl).* 2004; 176:386–397. [PubMed: 15138758]
- Pastor R, McKinnon CS, Scibelli AC, Burkhart-Kasch S, Reed C, Ryabinin AE, Coste SC, Stenzel-Poore MP, Phillips TJ. Corticotropin-releasing factor-1 receptor involvement in behavioral neuroadaptation to ethanol: a urocortin1-independent mechanism. *Proc Natl Acad Sci U S A.* 2008; 105:9070–9075. [PubMed: 18591672]
- Pastor R, Reed C, Burkhart-Kasch S, Li N, Sharpe AL, Coste SC, Stenzel-Poore MP, Phillips TJ. Ethanol concentration-dependent effects and the role of stress on ethanol drinking in corticotropin-releasing factor type 1 and double type 1 and 2 receptor knockout mice. *Psychopharmacology (Berl).* 2011; 218:169–177. [PubMed: 21487655]
- Pastor R, Reed C, Meyer PJ, McKinnon C, Ryabinin AE, Phillips TJ. Role of corticotropin-releasing factor and corticosterone in behavioral sensitization to ethanol. *J Pharmacol Exp Ther.* 2012; 341:455–463. [PubMed: 22333290]
- Phillips TJ, Roberts AJ, Lessov CN. Behavioral sensitization to ethanol: genetics and the effects of stress. *Pharmacol Biochem Behav.* 1997; 57:487–493.
- Picetti R, Schlussman SD, Zhou Y, Ray B, Ducat E, Yuferov V, Kreek MJ. Addictions and stress: clues for cocaine pharmacotherapies. *Curr Pharm Des.* 2013; 19:7065–7080. [PubMed: 23574443]
- Pitts MW, Todorovic C, Blank T, Takahashi LK. The central nucleus of the amygdala and corticotropin-releasing factor: insights into contextual fear memory. *J Neurosci.* 2009; 29:7379–7388. [PubMed: 19494159]

- Potter E, Behan DP, Linton EA, Lowry PJ, Sawchenko PE, Vale WW. The central distribution of a corticotropin-releasing factor (CRF)-binding protein predicts multiple sites and modes of interaction with CRF. *Proc Natl Acad Sci U S A*. 1992; 89:4192–4196. [PubMed: 1315056]
- Przybycien-Szymanska MM, Rao YS, Pak TR. Binge-pattern alcohol exposure during puberty induces sexually dimorphic changes in genes regulating the HPA axis. *Am J Physiol Endocrinol Metab*. 2010; 298:E320–E328. [PubMed: 19952347]
- Przybycien-Szymanska MM, Mott NN, Pak TR. Alcohol dysregulates corticotropin-releasing-hormone (CRH) promoter activity by interfering with the negative glucocorticoid response element (nGRE). *PLoS One*. 2011; 6:e26647.10.1371/journal.pone.0026647 [PubMed: 22039522]
- Radley JJ. Toward a limbic cortical inhibitory network: implications for hypothalamic-pituitary-adrenal responses following chronic stress. *Front Behav Neurosci*. 2012; 6:7.10.3389/fnbeh.2012.00007 [PubMed: 22479241]
- Rasmussen DD, Boldt BM, Bryant CA, Mitton DR, Larsen SA, Wilkinson CW. Chronic daily ethanol and withdrawal: 1. Long-term changes in the hypothalamo-pituitary-adrenal axis. *Alcohol Clin Exp Res*. 2000; 24:1836–1849. [PubMed: 11141043]
- Rassnick S, Heinrichs SC, Britton KT, Koob GF. Microinjection of a corticotropin-releasing factor antagonist into the central nucleus of the amygdala reverses anxiogenic-like effects of ethanol withdrawal. *Brain Res*. 1993; 605:25–32. [PubMed: 8467387]
- Ravenelle R, Byrnes EM, Byrnes JJ, McInnis C, Park JH, Donaldson ST. Environmental enrichment effects on the neurobehavioral profile of selective outbred trait anxiety rats. *Behav Brain Res*. 2013; 252:49–57. [PubMed: 23727174]
- Refojo D, Schweizer M, Kuehne C, Ehrenberg S, Thoeninger C, Vogl AM, Dedic N, Schumacher M, von Wolff G, Avrabos C, Touma C, Engblom D, Schutz G, Nave KA, Eder M, Wotjak CT, Sillaber I, Holsboer F, Wurst W, Deussing JM. Glutamatergic and dopaminergic neurons mediate anxiogenic and anxiolytic effects of CRHR1. *Science*. 2011; 333:1903–1907. [PubMed: 21885734]
- Reul JM, Holsboer F. On the role of corticotropin-releasing hormone receptors in anxiety and depression. *Dialogues Clin Neurosci*. 2002; 4:31–46. [PubMed: 22033745]
- Reyes TM, Lewis K, Perrin MH, Kunitake KS, Vaughan J, Arias CA, Hogenesch JB, Gulyas J, Rivier J, Vale WW, Sawchenko PE. Urocortin II: a member of the corticotropin-releasing factor (CRF) neuropeptide family that is selectively bound by type 2 CRF receptors. *Proc Natl Acad Sci U S A*. 2001; 98:2843–2848. [PubMed: 11226328]
- Reyes BAS, Valentino RJ, Bockstaele Van. Stress-induced intracellular trafficking of corticotropin-releasing factor receptors in rat locus coeruleus neurons. *Endocrinology*. 2008; 149:122–130. [PubMed: 17947354]
- Richardson HN, Lee SY, O'Dell LE, Koob GF, Rivier CL. Alcohol self-administration acutely stimulates the hypothalamic-pituitary-adrenal axis, but alcohol dependence leads to a dampened neuroendocrine state. *Eur J Neurosci*. 2008a; 28:1641–1653. [PubMed: 18979677]
- Richardson HN, Zhao Y, Fekete EM, Funk CK, Wirsching P, Janda KD, Zorrilla EP, Koob GF. MPZP: a novel small molecule corticotropin-releasing factor type 1 receptor (CRF1) antagonist. *Pharm Biochem Behav*. 2008b; 88:497–510.
- Richter RM, Zorrilla EP, Basso AM, Koob GF, Weiss F. Altered amygdalar CRF release and increased anxiety-like behavior in Sardinian alcohol-preferring rats: a microdialysis and behavioral study. *Alcohol Clin Exp Res*. 2000; 24:1765–1772. [PubMed: 11141034]
- Rivier C. Alcohol stimulates ACTH secretion in the rat: mechanisms of action and interactions with other stimuli. *Alcohol Clin Exp Res*. 1996; 20:240–254. [PubMed: 8730214]
- Rivier C. Role of hypothalamic corticotropin-releasing factor in mediating alcohol-induced activation of the rat hypothalamic-pituitary-adrenal axis. *Front Neuroendocrinol*. 2014; 35:221–233. [PubMed: 24211830]
- Rivier C, Vale W. Interaction of corticotropin-releasing factor and arginine vasopressin on adrenocorticotropin secretion in vivo. *Endocrinology*. 1983a; 113:939–942. [PubMed: 6307672]
- Rivier C, Vale W. Modulation of stress-induced ACTH release by corticotropin-releasing factor, catecholamines and vasopressin. *Nature*. 1983b; 305:325–327. [PubMed: 6312319]

- Rivier C, Rivier J, Vale W. Inhibition of adrenocorticotrophic hormone secretion in the rat by immunoneutralization of corticotropin-releasing factor. *Science*. 1982; 218:377–379. [PubMed: 6289439]
- Rivier C, Bruhn T, Vale W. Effect of ethanol on the hypothalamic-pituitary-adrenal axis in the rat: role of corticotropin-releasing factor (CRF). *J Pharmacol Exp Ther*. 1984; 229:127–131. [PubMed: 6323684]
- Roberto M, Cruz MT, Gilpin NW, Sabino V, Schweitzer P, Bajo M, Cottone P, Madamba SG, Stouffer DG, Zorrilla EP, Koob GF, Siggins GR, Parsons LH. Corticotropin releasing factor-induced amygdala gamma-aminobutyric acid release plays a key role in alcohol dependence. *Biol Psychiatry*. 2010; 67:831–839. [PubMed: 20060104]
- Roberto M, Gilpin NW, Siggins GR. The central amygdala and alcohol: role of gamma-aminobutyric acid, glutamate, and neuropeptides. *Cold Spring Harb Perspect Med*. 2012; 2:a012195.10.1101/cshperspect.a012195 [PubMed: 23085848]
- Roberts AJ, Lessov CN, Phillips TJ. Critical role for glucocorticoid receptors in stress- and ethanol-induced locomotor sensitization. *J Pharmacol Exp Ther*. 1995; 275:790–797. [PubMed: 7473168]
- Robinson TE, Berridge KC. The neural basis of drug craving: an incentive-sensitization theory of addiction. *Brain Res Brain Res Rev*. 1993; 18:247–291. [PubMed: 8401595]
- Robinson TE, Berridge KC. Review. The incentive sensitization theory of addiction: some current issues. *Philos Trans R Soc Lond B Biol Sci*. 2008; 363:3137–3146. [PubMed: 18640920]
- Roltsch EA, Baynes BB, Mayeux JP, Whitaker AM, Baiamonte BA, Gilpin NW. Predator odor stress alters corticotropin-releasing factor-1 receptor (CRF1R)-dependent behaviors in rats. *Neuropharmacology*. 2014; 79:83–89. [PubMed: 24269607]
- Ryabinin AE, Weitemier AZ. The urocortin 1 neurocircuit: ethanol-sensitivity and potential involvement in alcohol consumption. *Brain Res Rev*. 2006; 52:368–380. [PubMed: 16766036]
- Ryabinin AE, Tsivkovskaia NO, Ryabinin SA. Urocortin 1-containing neurons in the human Edinger-Westphal nucleus. *Neuroscience*. 2005; 134:1317–1323. [PubMed: 16039794]
- Ryabinin AE, Yoneyama N, Tanchuck MA, Mark GP, Finn DA. Urocortin 1 microinjection into the mouse lateral septum regulates the acquisition and expression of alcohol consumption. *Neuroscience*. 2008; 151:780–790. [PubMed: 18164138]
- Ryabinin AE, Tsoory MM, Kozicz T, Thiele TE, Neufeld-Cohen A, Chen A, Lowery-Gionta EG, Giardino WJ, Kaur S. Urocortins: CRF's siblings and their potential role in anxiety, depression and alcohol drinking behavior. *Alcohol*. 2012; 46:349–357. [PubMed: 22444954]
- Sabino V, Cottone P, Koob GF, Steardo L, Lee MJ, Rice KC, Zorrilla EP. Dissociation between opioid and CRF1 antagonist sensitive drinking in Sardinian alcohol-preferring rats. *Psychopharmacology (Berl)*. 2006; 189:175–186. [PubMed: 17047935]
- Sabino V, Kwak J, Rice KC, Cottone P. Pharmacological characterization of the 20% alcohol intermittent access model in Sardinian alcohol-preferring rats: a model of binge-like drinking. *Alcohol Clin Exp Res*. 2013; 37:635–643. [PubMed: 23126554]
- Sahuque LL, Kullberg EF, McGeehan AJ, Kinder JR, Hicks MP, Blanton MG, Janak PH, Olive MF. Anxiogenic and aversive effects of corticotropin-releasing factor (CRF) in the bed nucleus of the stria terminalis in the rat: role of CRF receptor subtypes. *Psychopharmacology (Berl)*. 2006; 186:122–132. [PubMed: 16568282]
- Salamone JD, Correa M. The mysterious motivational functions of mesolimbic dopamine. *Neuron*. 2012; 76:470–485. [PubMed: 23141060]
- Sanchis-Segura C, Spanagel R. Behavioural assessment of drug reinforcement and addictive features in rodents: an overview. *Addict Biol*. 2006; 11:2–38. [PubMed: 16759333]
- Sarnyai Z, Shaham Y, Heinrichs SC. The role of corticotropin-releasing factor in drug addiction. *Pharmacol Rev*. 2001; 53:209–243. [PubMed: 11356984]
- Sawchenko PE, Swanson LW, Vale WW. Corticotropin-releasing factor: co-expression within distinct subsets of oxytocin-, vasopressin-, and neurotensin-immunoreactive neurons in the hypothalamus of the male rat. *J Neurosci*. 1984; 4:1118–1129. [PubMed: 6609226]
- Schultz W. Updating dopamine reward signals. *Curr Opin Neurobiol*. 2013; 23:229–238. [PubMed: 23267662]

- Seasholtz AF, Valverde RA, Denver RJ. Corticotropin-releasing hormone-binding protein: biochemistry and function from fishes to mammals. *J Endocrinol.* 2002; 175:89–97. [PubMed: 12379493]
- Segat HJ, Kronbauer M, Roversi K, Schuster AJ, Vey LT, Roversi K, Pase CS, Antoniazzi CT, Burger ME. Exercise modifies amphetamine relapse: behavioral and oxidative markers in rats. *Behav Brain Res.* 2014; 262:94–100. [PubMed: 24445072]
- Shalev U, Erb S, Shaham Y. Role of CRF and other neuropeptides in stress-induced reinstatement of drug seeking. *Brain Res.* 2010; 1314:15–28. [PubMed: 19631614]
- Sharpe AL, Phillips TJ. Central urocortin 3 administration decreases limited-access ethanol intake in nondependent mice. *Behav Pharmacol.* 2009; 20:346–351. [PubMed: 19581799]
- Sharpe AL, Coste SC, Burkhart-Kasch S, Li N, Stenzel-Poore MP, Phillips TJ. Mice deficient in corticotropin-releasing factor receptor type 2 exhibit normal ethanol-associated behaviors. *Alcohol Clin Exp Res.* 2005; 29:1601–1609. [PubMed: 16205360]
- Shepard JD, Schulkin J, Myers DA. Chronically elevated corticosterone in the amygdala increases corticotropin releasing factor mRNA in the dorsolateral bed nucleus of stria terminalis following duress. *Behav Brain Res.* 2006; 174:193–196. [PubMed: 16934343]
- Silberman Y, Winder DG. Emerging role for corticotropin releasing factor signaling in the bed nucleus of the stria terminalis at the intersection of stress and reward. *Front Psychiatry.* 2013; 4:42.10.3389/fpsy.2013.00042 [PubMed: 23755023]
- Silberman Y, Bajo M, Chappell AM, Christian DT, Cruz M, Diaz MR, Kash T, Lack AK, Messing RO, Siggins GR, Winder D, Roberto M, McCool BA, Weiner JL. Neurobiological mechanisms contributing to alcohol-stress-anxiety interactions. *Alcohol.* 2009; 43:509–519. [PubMed: 19913194]
- Silberman Y, Matthews RT, Winder DG. A corticotropin releasing factor pathway for ethanol regulation of the ventral tegmental area in the bed nucleus of the stria terminalis. *J Neurosci.* 2013; 33:950–960. [PubMed: 23325234]
- Sillaber I, Rammes G, Zimmermann S, Mahal B, Zieglgans-berger W, Wurst W, Holsboer F, Spanagel R. Enhanced and delayed stress-induced alcohol drinking in mice lacking functional CRH1 receptors. *Science.* 2002; 296:931–933. [PubMed: 11988580]
- Silva SM, Santos-Marques MJ, Madeira MD. Sexually dimorphic response of the hypothalamo-pituitary-adrenal axis to chronic alcohol consumption and withdrawal. *Brain Res.* 2009; 1303:61–73. [PubMed: 19799878]
- Simms JA, Nielsen CK, Li R, Bartlett SE. Intermittent access ethanol consumption dysregulates CRF function in the hypothalamus and is attenuated by the CRF-R1 antagonist, CP-376395. *Addict Biol.* 2014; 19:606–611. [PubMed: 23362976]
- Sinclair D, Purves-Tyson TD, Allen KM, Weickert CS. Impacts of stress and sex hormones on dopamine neurotransmission in the adolescent brain. *Psychopharmacology (Berl).* 2014; 231:1581–1599. [PubMed: 24481565]
- Sinha R. Chronic stress, drug use, and vulnerability to addiction. *Ann N Y Acad Sci.* 2008; 1141:105–130. [PubMed: 18991954]
- Soliman A, O'Driscoll GA, Pruessner J, Holahan AL, Boileau I, Gagnon D, Dagher A. Stress-induced dopamine release in humans at risk of psychosis: a [<sup>11</sup>C]raclopride PET study. *Neuropsychopharmacology.* 2008; 33:2033–2041. [PubMed: 17957215]
- Solinas M, Chauvet C, Thiriet N, El Rawas R, Jaber M. Reversal of cocaine addiction by environmental enrichment. *Proc Natl Acad Sci U S A.* 2008; 105:17145–17150. [PubMed: 18955698]
- Sommer WH, Saavedra JM. Targeting brain angiotensin and corticotrophin-releasing hormone systems interaction for the treatment of mood and alcohol use disorders. *J Mol Med (Berl).* 2008; 86:723–728. [PubMed: 18449521]
- Sommer WH, Rimondini R, Hansson AC, Hipskind PA, Gehlert DR, Barr CS, Heilig MA. Upregulation of voluntary alcohol intake, behavioral sensitivity to stress, and amygdala *crhr1* expression following a history of dependence. *Biol Psychiatry.* 2008; 63:139–145. [PubMed: 17585886]

- Spanagel R, Noori HR, Heilig M. Stress and alcohol interactions: animal studies and clinical significance. *Trends Neurosci.* 2014; 37:219–227. [PubMed: 24636458]
- Sparta DR, Sparrow AM, Lowery EG, Fee JR, Knapp DJ, Thiele TE. Blockade of the corticotropin releasing factor type 1 receptor attenuates elevated ethanol drinking associated with drinking in the dark procedures. *Alcohol Clin Exp Res.* 2008; 32:259–265. [PubMed: 18162072]
- Sparta DR, Ferraro FM III, Fee JR, Knapp DJ, Breese GR, Thiele TE. The alcohol deprivation effect in C57BL/6J mice is observed using operant self-administration procedures and is modulated by CRF-1 receptor signaling. *Alcohol Clin Exp Res.* 2009; 33:31–42. [PubMed: 18945225]
- Sparta DR, Hopf FW, Gibb SL, Cho SL, Stuber GD, Messing RO, Ron D, Bonci A. Binge ethanol-drinking potentiates corticotropin releasing factor R1 receptor activity in the ventral tegmental area. *Alcohol Clin Exp Res.* 2013; 37:1680–1687. [PubMed: 23763790]
- Spieß J, Rivier J, Rivier C, Vale W. Primary structure of corticotropin-releasing factor from ovine hypothalamus. *Proc Natl Acad Sci USA.* 1981; 78:6517–6521. [PubMed: 6273874]
- Sprow GM, Thiele TE. The neurobiology of binge-like ethanol drinking: evidence from rodent models. *Physiol Behav.* 2012; 106:325–331. [PubMed: 22245775]
- Steckler T, Holsboer F. Corticotropin-releasing hormone receptor subtypes and emotion. *Biol Psychiatry.* 1999; 46:1480–1508. [PubMed: 10599478]
- Stengel A, Tache Y. CRF and urocortin peptides as modulators of energy balance and feeding behavior during stress. *Front Neurosci.* 2014; 8:52.10.3389/fnins.2014.00052 [PubMed: 24672423]
- Stephens MA, Wand G. Stress and the HPA axis: role of glucocorticoids in alcohol dependence. *Alcohol Res.* 2012; 34:468–483. [PubMed: 23584113]
- Stinus L, Cador M, Zorrilla EP, Koob GF. Buprenorphine and a CRF1 antagonist block the acquisition of opiate withdrawal-induced conditioned place aversion in rats. *Neuropsychopharmacology.* 2005; 30:90–98. [PubMed: 15138444]
- Swanson LW, Sawchenko PE, Rivier J, Vale WW. Organization of ovine corticotropin-releasing factor immunoreactive cells and fibers in the rat brain: an immunohistochemical study. *Neuroendocrinology.* 1983; 36:165–186. [PubMed: 6601247]
- Tanaka Y, Makino S, Noguchi T, Tamura K, Kaneda T, Hashimoto K. Effect of stress and adrenalectomy on urocortin II mRNA expression in the hypothalamic paraventricular nucleus of the rat. *Neuroendocrinology.* 2003; 78:1–11. [PubMed: 12869794]
- Thiele TE. Commentary: studies on binge-like ethanol drinking may help to identify the neurobiological mechanisms underlying the transition to dependence. *Alcohol Clin Exp Res.* 2012; 36:193–196. [PubMed: 22283808]
- Thorberg FA, Lyvers M. Negative mood regulation (NMR) expectancies, mood, and affect intensity among clients in substance disorder treatment facilities. *Addict Behav.* 2006; 31:811–820. [PubMed: 15993006]
- Thorsell A, Slawecki CJ, Ehlers CL. Effects of neuropeptide Y and corticotropin-releasing factor on ethanol intake in Wistar rats: interaction with chronic ethanol exposure. *Behav Brain Res.* 2005; 161:133–140. [PubMed: 15904720]
- Tran L, Greenwood-Van Meerveld B. Altered expression of glucocorticoid receptor and corticotropin-releasing factor in the central amygdala in response to elevated corticosterone. *Behav Brain Res.* 2012; 234:380–385. [PubMed: 22814115]
- Treutlein J, Kissling C, Frank J, Wiemann S, Dong L, Depner M, Saam C, Lascorz J, Soyka M, Preuss UW, Rujescu D, Skowronek MH, Rietschel M, Spanagel R, Heinz A, Laucht M, Mann K, Schumann G. Genetic association of the human corticotropin releasing hormone receptor 1 (CRHR1) with binge drinking and alcohol intake patterns in two independent samples. *Mol Psychiatry.* 2006; 11:594–602. [PubMed: 16550213]
- Turek VF, Tsivkovskaia NO, Hyytia P, Harding S, Le AD, Ryabinin AE. Urocortin 1 expression in five pairs of rat lines selectively bred for differences in alcohol drinking. *Psychopharmacology (Berl).* 2005; 181:511–517.
- Uhart M, Wand GS. Stress, alcohol and drug interaction: an update of human research. *Addict Biol.* 2009; 14:43–64. [PubMed: 18855803]



- Ungless MA, Singh V, Crowder TL, Yaka R, Ron D, Bonci A. Corticotropin-releasing factor requires CRF binding protein to potentiate NMDA receptors via CRF receptor 2 in dopamine neurons. *Neuron*. 2003; 39:401–407. [PubMed: 12895416]
- Valdez GR, Koob GF. Allostasis and dysregulation of corticotropin-releasing factor and neuropeptide Y systems: implications for the development of alcoholism. *Pharmacol Biochem Behav*. 2004; 79:671–689. [PubMed: 15582675]
- Valdez GR, Roberts AJ, Chan K, Davis H, Brennan M, Zorrilla EP, Koob GF. Increased ethanol self-administration and anxiety-like behavior during acute ethanol withdrawal and protracted abstinence: regulation by corticotropin-releasing factor. *Alcohol Clin Exp Res*. 2002; 26:1494–1501. [PubMed: 12394282]
- Valdez GR, Zorrilla EP, Roberts AJ, Koob GF. Antagonism of corticotropin-releasing factor attenuates the enhanced responsiveness to stress observed during protracted ethanol abstinence. *Alcohol*. 2003; 29:55–60. [PubMed: 12782246]
- Valdez GR, Sabino V, Koob GF. Increased anxiety-like behavior and ethanol self-administration in dependent rats: reversal via corticotropin-releasing factor-2 receptor activation. *Alcohol Clin Exp Res*. 2004; 28:865–872. [PubMed: 15201629]
- Vale W, Spiess J, Rivier C, Rivier J. Characterization of a 41-residue ovine hypothalamic peptide that stimulates secretion of corticotropin and beta-endorphin. *Science*. 1981; 213:1394–1397. [PubMed: 6267699]
- Vale W, Vaughan J, Smith M, Yamamoto G, Rivier J, Rivier C. Effects of synthetic ovine corticotropin-releasing factor, glucocorticoids, catecholamines, neurohypophysial peptides, and other substances on cultured corticotropic cells. *Endocrinology*. 1983; 113:1121–1131. [PubMed: 6307665]
- Van Pett K, Viau V, Bittencourt JC, Chan RK, Li HY, Arias C, Prins GS, Perrin M, Vale W, Sawchenko PE. Distribution of mRNAs encoding CRF receptors in brain and pituitary of rat and mouse. *J Comp Neurol*. 2000; 428:191–212. [PubMed: 11064361]
- Van Waes V, Darnaudery M, Marrocco J, Gruber SH, Talavera E, Mairesse J, Van Camp G, Casolla B, Nicoletti F, Mathe AA, Maccari S, Morley-Fletcher S. Impact of early life stress on alcohol consumption and on the short- and long-term responses to alcohol in adolescent female rats. *Behav Brain Res*. 2011; 221:43–49. [PubMed: 21376087]
- Vaughan J, Donaldson C, Bittencourt J, Perrin MH, Lewis K, Sutton S, Chan R, Turnbull AV, Lovejoy D, Rivier C, et al. Urocortin, a mammalian stress-induced increases in EtOH intake to be absent in CRF<sub>1</sub> KO mice. *Nature*. 1995; 378:287–292. [PubMed: 7477349]
- Vendruscolo LF, Roberts AJ. Operant alcohol self-administration in dependent rats: focus on the vapor model. *Alcohol*. 2014; 48:277–286. [PubMed: 24290310]
- Vendruscolo LF, Barbier E, Schlosburg JE, Misra KK, Whitfield TW Jr, Logrip ML, Rivier C, Repunte-Canonigo V, Zorrilla EP, Sanna PP, Heilig M, Koob GF. Corticosteroid-dependent plasticity mediates compulsive alcohol drinking in rats. *J Neurosci*. 2012; 32:7563–7571. [PubMed: 22649234]
- Walker DL, Davis M. Role of the extended amygdala in short-duration versus sustained fear: a tribute to Dr. Lennart Heimer. *Brain Struct Funct*. 2008; 213:29–42. [PubMed: 18528706]
- Walker DL, Miles LA, Davis M. Selective participation of the bed nucleus of the stria terminalis and CRF in sustained anxiety-like versus phasic fear-like responses. *Prog Neuropsychopharmacol Biol Psychiatry*. 2009; 33:1291–1308. [PubMed: 19595731]
- Wand GS, Dobs AS. Alterations in the hypothalamic-pituitary-adrenal axis in actively drinking alcoholics. *J Clin Endocrinol Metab*. 1991; 72:1290–1295. [PubMed: 2026749]
- Weiss F, Ciccocioppo R, Parsons LH, Katner S, Liu X, Zorrilla EP, Valdez GR, Ben-Shahar O, Angeletti S, Richter RR. Compulsive drug-seeking behavior and relapse. Neuroadaptation, stress, and conditioning factors. *Ann N Y Acad Sci*. 2001; 937:1–26. [PubMed: 11458532]
- Weitemier AZ, Ryabinin AE. Urocortin 1 in the dorsal raphe regulates food and fluid consumption, but not ethanol preference in C57BL/6J mice. *Neuroscience*. 2006; 137:1439–1445. [PubMed: 16338088]

- Wills TA, Knapp DJ, Overstreet DH, Breese GR. Sensitization, duration, and pharmacological blockade of anxiety-like behavior following repeated ethanol withdrawal in adolescent and adult rats. *Alcohol Clin Exp Res*. 2009; 33:455–463. [PubMed: 19120055]
- Wills TA, Knapp DJ, Overstreet DH, Breese GR. Interactions of stress and CRF in ethanol-withdrawal induced anxiety in adolescent and adult rats. *Alcohol Clin Exp Res*. 2010; 34:1603–1612. [PubMed: 20586753]
- Wise RA. Dopamine and reward: the anhedonia hypothesis 30 years on. *Neurotox Res*. 2008; 14:169–183. [PubMed: 19073424]
- Wise RA, Koob GF. The development and maintenance of drug addiction. *Neuropsychopharmacology*. 2014; 39:254–262. [PubMed: 24121188]
- Wise RA, Morales M. A ventral tegmental CRF-glutamate-dopamine interaction in addiction. *Brain Res*. 2010; 1314:38–43. [PubMed: 19800323]
- Wong CC, Schumann G. Integration of the circadian and stress systems: influence of neuropeptides and implications for alcohol consumption. *J Neural Transm*. 2012; 119:1111–1120. [PubMed: 22648536]
- Xu J, Sun J, Xue Z, Li X. An enriched environment reduces the stress level and locomotor activity induced by acute morphine treatment and by saline after chronic morphine treatment in mice. *Neuroreport*. 2014; 25:701–709. [PubMed: 24709916]
- Yang X, Wang S, Rice KC, Munro CA, Wand GS. Restraint stress and ethanol consumption in two mouse strains. *Alcohol Clin Exp Res*. 2008; 32:840–852. [PubMed: 18336636]
- Yong W, Spence JP, Eskay R, Fitz SD, Damadzic R, Lai D, Foroud T, Carr LG, Shekhar A, Chester JA, Heilig M, Liang T. Alcohol-preferring rats show decreased corticotropin-releasing hormone-2 receptor expression and differences in HPA activation compared to alcohol-nonpreferring rats. *Alcohol Clin Exp Res*. 2014; 38:1275–1283. [PubMed: 24611993]
- Zhao Z, Jin X, Wu Y, Yang X, Xu Y, Jiang JZ, Kim SC, Lee BH, Yang CH, Zhao R. Amygdaloid corticotropin-releasing factor is involved in the anxiolytic effect of acupuncture during ethanol withdrawal in rats. *J Acupunct Meridian Stud*. 2013; 6:234–240. [PubMed: 24139460]
- Zhou Y, Colombo G, Gessa GL, Kreek MJ. Effects of voluntary alcohol drinking on corticotropin-releasing factor and preprodynorphin mRNA levels in the central amygdala of Sardinian alcohol-preferring rats. *Neurosci Lett*. 2013; 554:110–114. [PubMed: 24021806]
- Zorrilla EP, Koob GF. The therapeutic potential of CRF1 antagonists for anxiety. *Expert Opin Investig Drugs*. 2004; 13:799–828.
- Zorrilla EP, Koob GF. Progress in corticotropin-releasing factor-1 antagonist development. *Drug Discov Today*. 2010; 15:371–383. [PubMed: 20206287]
- Zorrilla EP, Valdez GR, Nozulak J, Koob GF, Markou A. Effects of antalarmin, a CRF type 1 receptor antagonist, on anxiety-like behavior and motor activation in the rat. *Brain Res*. 2002; 952:188–199. [PubMed: 12376179]
- Zorrilla EP, Heilig M, de Wit H, Shaham Y. Behavioral, biological, and chemical perspectives on targeting CRF(1) receptor antagonists to treat alcoholism. *Drug Alcohol Depend*. 2013; 128:175–186. [PubMed: 23294766]
- Zorrilla EP, Logrip ML, Koob GF. Corticotropin releasing factor: a key role in the neurobiology of addiction. *Front Neuroendocrinol*. 2014; 35:234–244. [PubMed: 24456850]

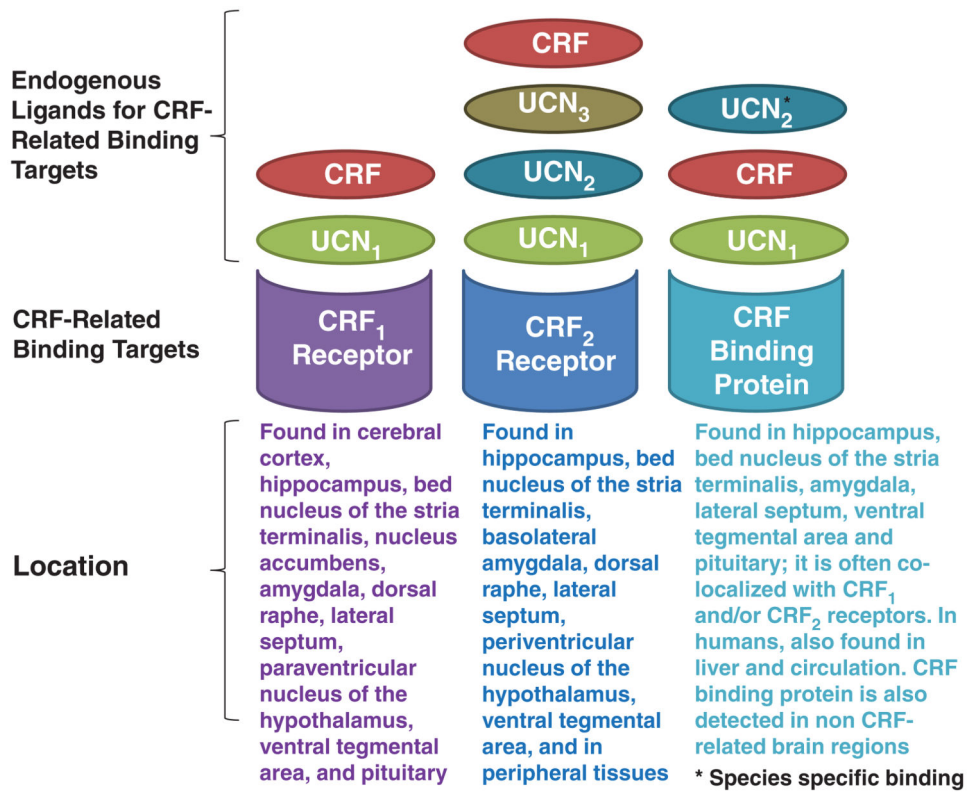

**Figure 1. Binding relationships of CRF-family peptides and their targets**

CRF binds with high affinity to CRF<sub>1</sub> and CRF-BP and with lower affinity to CRF<sub>2</sub>. Ucn<sub>1</sub> binds with high affinity to CRF<sub>1</sub>, CRF<sub>2</sub> and CRF-BP. Ucn<sub>2</sub> and Ucn<sub>3</sub> are selective for CRF<sub>2</sub> in all species; Ucn<sub>2</sub> has an affinity for CRF-BP in certain species. Those with the highest affinity for the binding target are placed closest to that target while those with the lowest affinity are placed farthest away. The locations shown for CRF<sub>1</sub>, CRF<sub>2</sub> and CRF-BP are not inclusive, but are those most relevant to this review. For additional information, see De Souza (1995); Hauger *et al.* (2006); Huising *et al.* (2008); Kühne *et al.* (2012).

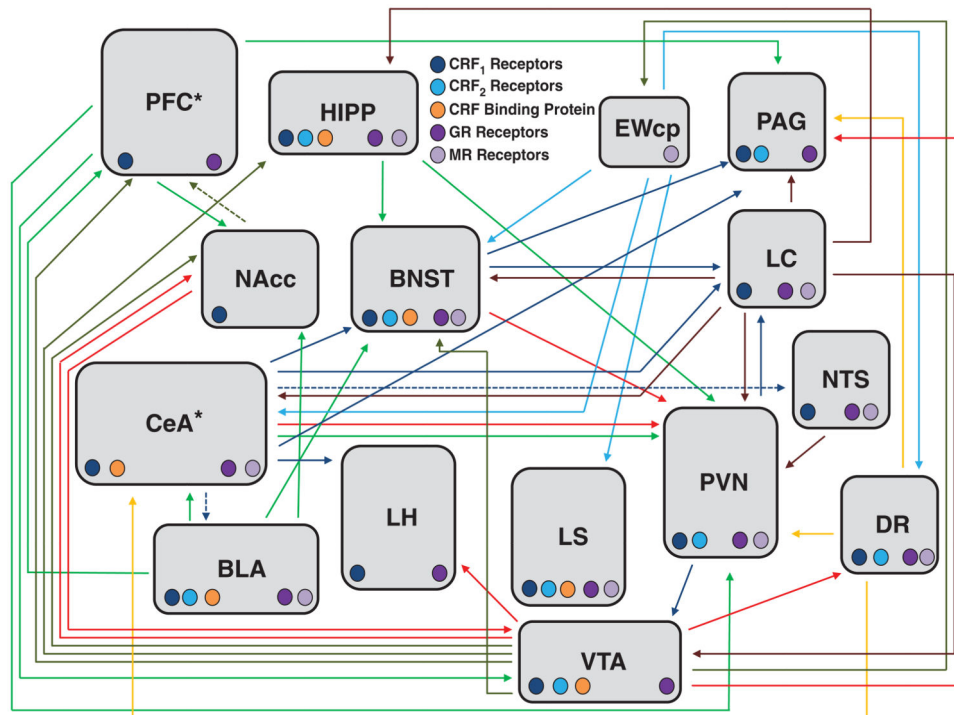

**Figure 2. Diagram of central CRF-related neurocircuitry and interactions with other neurotransmitter systems**

In this figure, we concentrate on the CRF neurocircuitry that we discuss in this article in relationship to EtOH drinking and neuroadaptation-related phenotypes; however, not all potentially relevant regions and pathways are represented. Colored circles within each brain region denote the CRF-related receptor or CRF-BP that is found in that region, with colors defined in the figure. Lines and arrows indicate the projections from one specific brain region to another, with the color denoting the primary transmitter or peptide. CRF projection, solid dark blue line and arrow; speculated CRF projections, dashed dark blue line and arrow; DA projection, solid dark green line and arrow; GABA projection, solid red line and arrow; glutamate projection, solid green line and arrow; norepinephrine projection, solid brown line and arrow; serotonin projection, solid yellow line and arrow; Ucn<sub>1</sub> projection, solid light blue line and arrow. Brain regions: BLA, basolateral nucleus of the amygdala; HIPP, hippocampus; LH, lateral hypothalamus; LS, lateral septum; NTS, nucleus of the solitary tract; PFC, prefrontal cortex; \* denotes that there are multiple divisions within this region that contain varying levels of each of the noted binding targets. These subdivisions may inferentially alter the roles CRF plays in EtOH-related behaviors. For additional information, see Ahima *et al.* (1991); Bittencourt *et al.* (1999); Brown (1986); Cowen *et al.* (2004); Duvarci and Pare (2014); George and Koob (2010); Gilpin (2012); Gray and Magnuson (1992); Haass-Koffler and Bartlett (2012); Handa and Weiser (2014); Hauger *et al.* (2006); Justice *et al.* (2008); Korosi *et al.* (2006); Kühne *et al.* (2012); Lu and Richardson (2014); Myers *et al.* (2014); Pitts *et al.* (2009); Potter *et al.* (1992); Radley (2012); Reul and Holsboer (2002); Reyes *et al.* (2008); Ryabinin and Weitemier (2006); Silberman and Winder (2013); Silberman *et al.* (2013); Sinha (2008); Van Pett *et al.* (2000); Wise and Morales (2010).

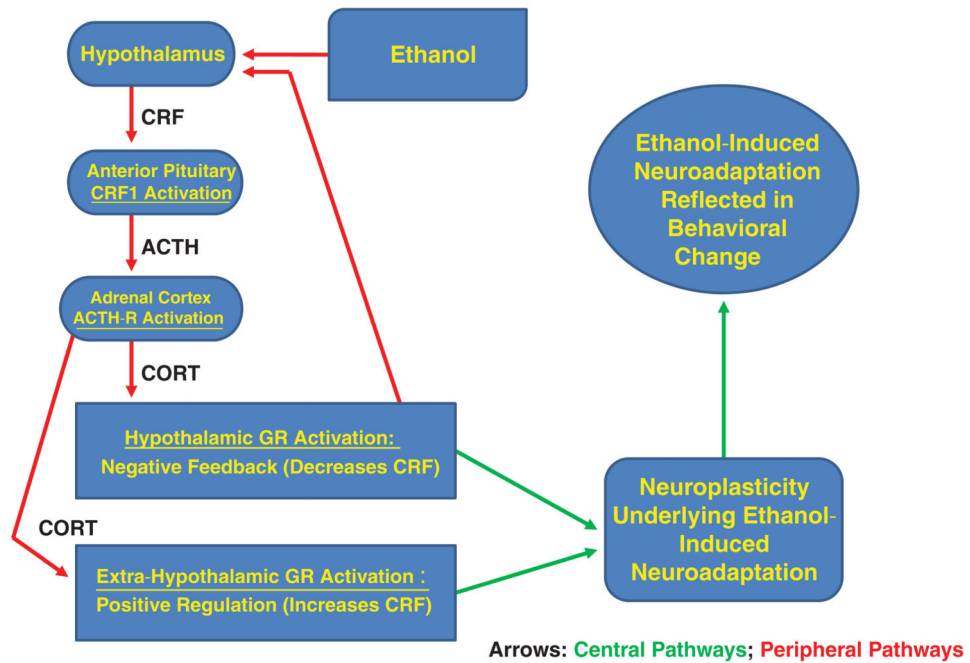

**Figure 3. The HPA axis and central CRF processes in EtOH-induced neuroadaptations**  
 EtOH activates the HPA axis and induces a well-known cascade of events: CRF is released from the hypothalamus and binds to CRF<sub>1</sub> in the anterior pituitary, resulting in ACTH release; ACTH receptor (ACTH-R) activation results in CORT release from the adrenal cortex. Hypothalamic GR activation reduces CRF release via a negative feedback loop. CORT also regulates an extra-hypothalamic positive regulatory mechanism that increases CRF activity. GR activation plays a role in EtOH-induced neuroadaptation, with a role for long-lasting changes in hypothalamic and extra-hypothalamic structures.



**Table 1**  
**Studies of EtOH drinking and neuroadaptation in KO and transgenic mice**

Gene	Reference	Sex/background	Trait	Results
CRF	Olive <i>et al.</i> (2003)	129S2/SvPas × C57BL/6J	EtOH drinking; two-bottle choice, 23 h/day for 16 days (2–10% EtOH); or 2 h choice (10% EtOH) under 22 h/day fluid restriction for 3 days; EtOH-induced conditioned place preference for four EtOH conditioning trials (2 or 3 g/kg EtOH)	CRF KO mice consumed more EtOH than WT control mice in both 23 and 2 h access conditions. The conditioned rewarding effect of 2 g/kg EtOH was absent in KO mice, but present in WT. The genotypes showed equivalent conditioned rewarding effects of 3 g/kg EtOH
CRF	Kaur <i>et al.</i> (2012)	129S2/SvPas × C57BL/6J; male and female	EtOH drinking; single-bottle DID 2 h/day for 3 days, then 4 h/day on day 4 (20% EtOH)	CRF KO mice had reduced EtOH intake and BEC, compared with WT controls
CRF	Pastor <i>et al.</i> (2012)	129Sv/J × C57BL/6J	EtOH-induced locomotor sensitization; IP 2.5 g/kg EtOH once daily for 10 days, then IP 1.5 g/kg EtOH challenge and locomotor test; BEC and CORT levels	CRF KO mice did not develop EtOH-induced locomotor sensitization, whereas WT mice did; CRF KO mice had drastically reduced CORT plasma levels, compared with WT controls. BEC levels did not differ
CRF overexpression transgenic	Palmer <i>et al.</i> (2004)	C57BL/6J × SJL	EtOH drinking; two-bottle choice continuous access for 16 days (3–20% EtOH)	Transgenic mice consumed significantly less EtOH than their non-transgenic littermates. Older transgenic mice drank less EtOH than younger transgenic mice
CRF <sub>1</sub>	Sillaber <i>et al.</i> (2002)	129/SvJ × 129/Ola × CD1; male	EtOH drinking; two-bottle choice continuous access (2–8% EtOH for 18 days; then 8% EtOH for up to 9 months); exposure to swim and social defeat stress at 2 and 3 months	There was no initial difference in EtOH consumption between KO and WT mice; KO mice exposed to stress at 2 and 3 months consumed more EtOH than WT mice at 4–9 months. There was no stress effect on WT mice
CRF <sub>1</sub>	Nie <i>et al.</i> (2004)	C57BL/6J × 129Sv	GABA neurotransmission; brain slice electrophysiology	CRF (100 nM) or EtOH (44 mM) did not enhance GABA-mediated neurotransmission in the CeA in CRF <sub>1</sub> KO mice, but did in WT mice
CRF <sub>1</sub>	Chu <i>et al.</i> (2007)	129/Ola × CD1	EtOH self-administration training then EtOH liquid diet for 14 days (2–4% EtOH); EtOH WD effects on operant EtOH self-administration for 10 subsequent days	CRF <sub>1</sub> KO mice did not display EtOH WD-induced increases in EtOH self-administration, but WT mice did
CRF <sub>1</sub>	Pastor <i>et al.</i> (2008)	129SV/J × C57BL/6J	EtOH-induced locomotor sensitization; IP 2.5 g/kg EtOH once daily for 10 days, then IP 1.5 g/kg EtOH challenge and locomotor test; BEC and CORT levels	CRF <sub>1</sub> KO mice did not show the EtOH-induced locomotor sensitization seen in WT mice, and had a blunted CORT response to EtOH. BEC levels did not differ
CRF <sub>1</sub>	Pastor <i>et al.</i> (2011)	129SV/J × C57BL/6J	EtOH drinking; two-bottle choice continuous access for 16 days (3–20% EtOH); in a separate study, two-bottle intermittent access for 47 days (3–10% EtOH, and 21	EtOH intake (20% EtOH concentration only) was lower in CRF <sub>1</sub> KO mice compared with WT during continuous access; repeated swim stress, but not acute swim stress,

Gene	Reference	Sex/background	Trait	Results
			h/day); swim stress effects on EtOH drinking	resulted in higher levels of 21 h/day EtOH consumption in WT mice, but not CRF <sub>1</sub> KO mice
CRF <sub>1</sub>	Molander <i>et al.</i> (2012)	129/SvJ × 129/Ola × CD1; male	EtOH drinking; two-bottle choice continuous access for ~5 months (2–8% EtOH); EtOH vapor (four cycles of 16 h/day exposure); swim and social defeat stress effects on EtOH drinking	There was no initial difference in EtOH consumption between KO and WT mice; CRF <sub>1</sub> KO mice displayed greater social defeat-induced, but not forced swim stress-induced, increased EtOH intake, as well as greater EtOH WD-induced increases in EtOH intake, compared with WT controls
CRF <sub>1</sub>	Kaur <i>et al.</i> (2012)	129/Ola × CD1; male and female	EtOH drinking; single-bottle DID 2 h/day for 3 days, then 4 h/day on day 4 (20% EtOH)	CRF <sub>1</sub> KO mice had lower EtOH intake and BEC, compared with WT mice
CRF <sub>1</sub>	Giardino and Ryabinin (2013)	129/Ola × CD1 backcrossed to C57BL/6J	EtOH drinking; two-bottle DID 2 h/day for 3 days, then 4 h/day on day 4 (15% EtOH); water and food intake	EtOH intake was lower in CRF <sub>1</sub> KO mice, compared with WT mice; water intake and total caloric intake were also lower
CRF <sub>1</sub> <sup>NestinCre</sup>	Molander <i>et al.</i> (2012)	129S2/Sv × SJL × C57BL/6J	EtOH drinking; two-bottle choice continuous access for ~5 months (2–8% EtOH); EtOH vapor (four cycles of 16 h/day exposure); swim and social defeat stress effects on EtOH drinking	There was no initial difference in EtOH consumption between CRF <sub>1</sub> <sup>NestinCre</sup> KO and WT mice. Stress-induced increases in EtOH consumption were lower in CRF <sub>1</sub> <sup>NestinCre</sup> KO, compared with controls, and CRF <sub>1</sub> <sup>NestinCre</sup> KO mice did not display EtOH WD-induced increases in EtOH intake, whereas controls did
CRF <sub>2</sub>	Nie <i>et al.</i> (2004)	C57BL/6J × 129	GABA neurotransmission; brain slice electrophysiology	CRF (100 nM) and EtOH (44 mM) each enhanced GABA-mediated neurotransmission in the CeA in both WT and CRF <sub>2</sub> KO mice
CRF <sub>2</sub>	Sharpe <i>et al.</i> (2005)	129X1/SvJ × C57BL/6J	EtOH drinking; two-bottle choice continuous access for 16 days (3–20% EtOH); in a separate study, single-bottle DID (0.6–10% EtOH; 30 min/day for first 14 days and then 2 h/day for 6 days at 10% EtOH)	EtOH consumption was slightly reduced in CRF <sub>2</sub> mice, compared with WT littermates, at 7.5% and 10% concentrations, during limited access only
CRF <sub>2</sub>	Giardino <i>et al.</i> (2011)	129X1/SvJ × C57BL/6J	EtOH-induced conditioned place preference (IP 2 g/kg EtOH for 4 EtOH conditioning trials)	The conditioned rewarding effect of EtOH was absent in CRF <sub>2</sub> KO mice, compared with WT
CRF <sub>2</sub>	Kaur <i>et al.</i> (2012)	129X1/SvJ × C57BL/6J; male and female	EtOH drinking; single-bottle DID 2 h/day for 3 days, then 4 h/day on day 4 (20% EtOH)	CRF <sub>2</sub> KO mice had slightly reduced EtOH intake on the first day, compared with WT mice; this difference was not sustained on subsequent days and not accompanied by differences in BEC
CRF <sub>1/2</sub>	Pastor <i>et al.</i> (2008)	C57BL/6J × 129SV/J	EtOH-induced locomotor sensitization; IP 2.5 g/kg EtOH once daily for 10 days, then IP 1.5 g/kg EtOH	CRF <sub>1/2</sub> KO mice did not show the EtOH-induced locomotor sensitization seen in WT mice

Gene	Reference	Sex/background	Trait	Results
CRF <sub>1/2</sub>	Pastor <i>et al.</i> (2011)	C57BL/6J × 129SV/J	challenge and locomotor test; BEC and CORT levels  EtOH drinking; two-bottle choice for 47 days (3–10% EtOH, 21 h/day); swim stress effects on EtOH drinking	and had a blunted CORT response to EtOH. BEC levels did not differ  Repeated swim stress, but not acute swim stress, resulted in higher levels of EtOH consumption in WT, but not in CRF <sub>1/2</sub> KO mice.
Ucn <sub>1</sub>	Pastor <i>et al.</i> (2008)	C57BL/6J × 129SV/J	EtOH-induced locomotor sensitization; IP 2.5 g/kg EtOH once daily for 10 days, then IP 1.5 g/kg EtOH challenge and locomotor test	Ucn <sub>1</sub> KO mice displayed normal EtOH-induced locomotor sensitization
Ucn <sub>1</sub>	Giardino <i>et al.</i> (2011)	129X1/SvJ × C57BL/6J	EtOH drinking; two-bottle choice continuous access for 16 days (3–10% EtOH)	Ucn <sub>1</sub> KO mice consumed less of a 6%, but not 3% or 10% solution, compared with WT mice; KO mice showed reduced preference for both the 6% and 10% EtOH concentrations, compared with WT mice
Ucn <sub>1</sub>	Giardino <i>et al.</i> (2011)	129X1/SvJ × C57BL/6J	EtOH-induced conditioned place preference and aversion (IP 2 g/kg EtOH for four EtOH conditioning trials)	The conditioned rewarding effect of EtOH was absent in Ucn <sub>1</sub> KO mice, compared with WT; sensitivity to the conditioned aversive effect of EtOH was equivalent in the KO and WT mice
Ucn <sub>1</sub>	Kaur <i>et al.</i> (2012)	129X1/SvJ × C57BL/6J; male and female	EtOH drinking; single-bottle DID 2 h/day for 3 days, then 4 h/day on day 4 (20% EtOH)	Ucn <sub>1</sub> KO mice did not differ from WT mice in EtOH intake or BEC

BEC, blood ethanol concentration; WD, withdrawal.

**Table 2**  
**Pharmacological studies involving the CRF system and EtOH drinking and neuroadaptation**

Receptor, drug type	Drug	Reference	Model	Treatment or trait	Finding
CRF <sub>1/2</sub> -agonist	CRF	Ehlers <i>et al.</i> (1992)	P and NP rats	No EtOH treatment; drug given 25 min before EEG recording	ICV CRF (0.15 nmol, once) to P rats resulted in a significant increase in EEG theta waves in the frontal cortex, compared with data after vehicle. This was not seen in NP rats. When compared with NP rats, P rats had lower concentrations of CRF in the hypothalamus, amygdala, prefrontal cortex and cingulate cortex
	CRF	Bell <i>et al.</i> (1998)	Long Evans rats	EtOH drinking: single-bottle 1 h/day for 38 days (2–8% EtOH), then two-bottle choice for 1 h/day for 7 days (8% EtOH)	ICV CRF (0.5 and 5 µg/1.5 µl) dose-dependently decreased EtOH consumption during the two-bottle choice limited access procedure; 24-h food intake was also reduced
	CRF	Le <i>et al.</i> (2002)	Wistar rats	EtOH drinking: two-bottle choice for 30 min/day for 25 days (3–12% EtOH); then operant EtOH self-administration (12% EtOH) for 1 h/day for 18–25 days; extinction for 5–9 days; CRF given 15 min before reinstatement session	ICV (300 and 1000 ng) or intra-MRN (3 and 10 ng) CRF reinstated EtOH seeking
	CRF	Overstreet <i>et al.</i> (2004)	Sprague–Dawley rats	EtOH liquid diet for 5 days (7% EtOH); CRF treatment occurred twice, 6 days and 1 day prior to EtOH liquid diet exposure; social interaction testing occurred 30 min after the first CRF exposure and 5–6 h after WD	Social interaction is used to index anxiety-related behavior and is sensitive to EtOH WD and stress. ICV CRF (1 µg) reduced social interaction after the first treatment, prior to EtOH exposure; ICV CRF also reduced social interaction in EtOH WD rats
	CRF	O'Callaghan <i>et al.</i> (2005)	'High preference' and 'low preference' mice	EtOH drinking; 24-h two-bottle choice for 3 weeks (8% EtOH) to establish drinking, then CRF was given and intake was measured after 12, 24 and 36 h	ICV CRF (5 µg in 2 µl, once) did not alter EtOH preference in high or low preference mice
	CRF	Thorsell <i>et al.</i> (2005)	Wistar rats	Single-bottle 25 min/day EtOH access (2–10% EtOH), using sucrose fading for 3–4 weeks; EtOH vapor 14 h/day for 8 weeks; reestablishment of EtOH drinking for 7–10 sessions, then treatment effects examined 30 min after CRF administration	ICV CRF (1 µg in 5 µl) reduced EtOH intake in both control and EtOH vapor exposed rats
	CRF	Gabriel <i>et al.</i> (2006)	Sprague–Dawley rats	Prenatal EtOH liquid diet exposure throughout gestation (36% EtOH-derived calories); elevated plus maze testing at 60–90 days of age, 30 min after CRF infusion	Treatment with CRF (0.75–2 µg) had anxiogenic effects across prenatal treatment groups, with some effects being more profound in rats prenatally exposed to EtOH

Receptor, drug type	Drug	Reference	Model	Treatment or trait	Finding
	CRF	Weitemier and Ryabinin (2006)	C57/BL6J mice	EtOH drinking for one week; two-bottle choice continuous access (2.5% and then 5%); then cannulation surgery; then re-establishment of EtOH drinking (5%); effect of CRF 2 h after infusion	Intra-DR CRF (20 pmol in 50 nl) had no effect on the intake of EtOH, food or water during a 14-h period, beginning 2 h after treatment
	CRF	Ryabinin <i>et al.</i> (2008)	C57BL/6J mice	EtOH drinking; single-bottle DID 2 h/day for 3 days (20% EtOH); CRF effect examined on day 3 of EtOH drinking ~15 min after infusion	Intra-lateral septum CRF (6–60 pmol) dose-dependently suppressed both water and EtOH intake
	CRF	Huang <i>et al.</i> (2010)	Sprague–Dawley rats	CRF infused on days 6 and 12, while on control diet, followed by EtOH liquid diet for 5 days (4.5% EtOH); social interaction test and locomotor activity assessed 5 h after EtOH WD	Social interaction is used to index anxiety-related behavior and is sensitive to EtOH WD and stress. CRF (0.045–0.5 µg/site in 0.5 µl) microinjected into the CeA, BLA, DRN, or dorsal BNST, exacerbated reductions in social interactions seen in EtOH WD rats; there were no effects in non-EtOH exposed rats. This effect was not found for several other brain regions Locomotor activity was not affected
	CRF	Knapp <i>et al.</i> (2011a)	Inbred alcohol-preferring (IP) rats	EtOH drinking; single-bottle continuous access for 3 days (10% EtOH) then two-bottle choice continuous access for 15 days or 15 days with 2 days of WD every 5 days (10% EtOH); CRF given ~4 h after WD during the first two EtOH WD periods; drinking examined in subsequent 5-day periods; social interaction measured 5–6 h after the final (third) EtOH WD	Social interaction is used to index anxiety-related behavior and is sensitive to EtOH WD and stress. Intra-NAcc CRF (0.5 µg) exacerbated WD-increased drinking; this effect was not seen for the CeA, DRN, VTA or PVN. Intra-amygdala and intra-DRN CRF reduced social interaction time during EtOH WD; this effect was not seen for the NAcc, VTA or PVN
	CRF	Zhao <i>et al.</i> (2013)	Sprague–Dawley rats	IP 3 g/kg/day EtOH for 28 days; beginning 3 days after EtOH WD, acupuncture given for three consecutive days; CRF infused 5 min after third acupuncture treatment and rats tested on the elevated plus maze for 5 min, beginning 1 min after infusion	EtOH WD group spent less time on the open arms of the plus maze; acupuncture increased open arm time to non-WD group levels; intra-CeA CRF (0.2 µg in 0.2 µl/site) blocked this anxiolytic effect of acupuncture during EtOH WD
CRF <sub>1/2</sub> -agonist	Ucn <sub>1</sub>	Weitemier and Ryabinin (2006)	C57/BL6J mice	EtOH drinking for 1 week; two-bottle choice continuous access (2.5% and then 5%); then cannulation surgery; then re-establishment of EtOH drinking (5%); effect of Ucn <sub>1</sub> 2 h after infusion	Intra-DR Ucn <sub>1</sub> (20 pmol in 50 nl) had no effect on EtOH intake, but reduced food and water intake; reduced body weight gain was also seen
	Ucn <sub>1</sub>	Ryabinin <i>et al.</i> (2008)	C57BL/6J mice	EtOH drinking; single-bottle DID 2 h/day for 3 days (20% EtOH); effect of Ucn <sub>1</sub> examined on day 3 of EtOH drinking ~15 min after infusion; separate study examined Ucn <sub>1</sub> effect on acquisition of	Intra-lateral septum Ucn <sub>1</sub> (6–60 pmol) reduced established EtOH intake, but not water intake, with little dose-dependence Repeated Ucn <sub>1</sub> (0.1–40 pmol) dose-



Receptor, drug type	Drug	Reference	Model	Treatment or trait	Finding
CRF <sub>1/2</sub> antagonist	$\alpha$ -Helical CRF <sub>(9-41)</sub>	Baldwin <i>et al.</i> (1991)	Wistar rats	EtOH drinking; Ucn1 was infused immediately before EtOH access on all 3 days  EtOH liquid diet for 2–3 weeks (8.5–11.5% EtOH); 8 h after WD, CRF was infused and elevated plus maze test was conducted 30 min later for 5 min	dependently attenuated the acquisition of EtOH drinking  ICV $\alpha$ -helical CRF <sub>(9-41)</sub> (5 or 25 $\mu$ g) blocked the anxiogenic-like effects of EtOH WD on the elevated plus maze, seen in comparison with rats that received non-EtOH control diet; general WD symptoms were unaffected
	$\alpha$ -Helical CRF <sub>(9-41)</sub>	Rassnick <i>et al.</i> (1993)	Wistar rats	EtOH liquid diet for 16 days (8.7% EtOH); 8 h after WD, CRF was infused and elevated plus maze test was conducted 30 min later for 5 min	Intra-CeA $\alpha$ -helical CRF <sub>(9-41)</sub> (250 ng, but not 500 ng, given bilaterally in 0.5 $\mu$ l) blocked the decrease in percent time in the open arms of the elevated plus maze seen during EtOH WD; ICV $\alpha$ -helical CRF <sub>(9-41)</sub> (250 ng) had no significant effect
	$\alpha$ -Helical CRF <sub>(9-41)</sub>	O'Callaghan <i>et al.</i> (2005)	High preference and low preference mice	EtOH drinking; 24-h two-bottle choice for 3 weeks (8% EtOH) to establish drinking, then treatment was given and intake was after measured 12, 24 and 36 h	ICV $\alpha$ -helical CRF <sub>(9-41)</sub> (5 $\mu$ g in 2 $\mu$ l) had no effect on EtOH preference in high preference mice, but increased EtOH preference in low preference mice
	$\alpha$ -Helical CRF <sub>(9-41)</sub>	Lowery <i>et al.</i> (2010)	C57BL/6J mice	EtOH drinking; sucrose drinking; single-bottle DID 2 h/day for 3 days, then for 4 h on day 4 (20% EtOH); same procedure for 10% sucrose; drug given 60 min before day 4 EtOH or sucrose access; BEC	Only the lowest dose of ICV $\mu$ -helical CRF <sub>(9-41)</sub> (1, 5 or 10 $\mu$ g in 1 $\mu$ l) attenuated EtOH consumption. BEC was significantly reduced after treatment with both the 1 and 10 $\mu$ g doses. There was no effect on sucrose drinking (only 1 $\mu$ g dose tested)
CRF <sub>1/2</sub> antagonist	D-Phe-CRF <sub>(12-41)</sub>	Le <i>et al.</i> (2000)	Wistar rats	EtOH drinking; two-bottle choice intermittent access for 30 days (3–12% EtOH; 30 min/day); then operant self-administration for ~24 days (12% EtOH; 1 h/day); extinction for 5–8 days; reinstatement session or 15 min prior to intermittent footshock, which was administered just before reinstatement session	ICV D-Phe-CRF <sub>(12-41)</sub> (0.3 or 1 $\mu$ g in 2 $\mu$ l) dose-dependently attenuated footshock-induced reinstatement of EtOH seeking. The highest dose increased responding in the no-shock condition
	D-Phe-CRF <sub>(12-41)</sub>	Le <i>et al.</i> (2002)	Wistar rats	EtOH drinking; two-bottle choice for 30 min/day for 25 days (3–12% EtOH); then operant EtOH self-administration for 1 h/day for 18–25 days (12% EtOH); extinction for 5–9 days; treatment given 15 min prior to reinstatement session or 15 min prior to intermittent footshock, which was administered just before reinstatement session	Intra-MRN D-Phe-CRF <sub>(12-41)</sub> (50 ng) blocked footshock-induced reinstatement. There was no significant effect on the no-shock condition

Receptor, drug type	Drug	Reference	Model	Treatment or trait	Finding
	D-Phe-CRF <sub>(12-41)</sub>	Liu and Weiss (2002)	Wistar rats	Operant self-administration for ~9 weeks (5-10% EtOH; 30 min access), then continuous EtOH vapor for 10 days; then EtOH vapor for 12 h/day alternating with extinction beginning 7-10 days later for an average of 19 days; drug given 30 min before reinstatement test	ICV D-Phe-CRF <sub>(12-41)</sub> (1 or 10 µg in 5 µl) dose-dependently reduced footshock-induced, but not EtOH-conditioned cue-induced reinstatement of EtOH seeking in post-EtOH dependent rats; it also reduced stress plus EtOH cue-induced reinstatement; non-dependent rats were not studied
	D-Phe-CRF <sub>(12-41)</sub>	Valdez <i>et al.</i> (2002)	Wistar rats	Operant self-administration for ~9 weeks (5-10% EtOH; 30-60 min access), then continuous EtOH vapor for 3 weeks; effect of drug on operant EtOH self-administration was assessed 2 h or 2-5 weeks after WD, with sessions initiated 10 min after infusion	ICV D-Phe-CRF <sub>(12-41)</sub> (1, 5 or 10 µg in 5 µl) dose-dependently attenuated WD-induced increases in EtOH seeking at both 2 h and 2-5 weeks after WD
	D-Phe-CRF <sub>(12-41)</sub>	Valdez <i>et al.</i> (2003)	Wistar rats	EtOH liquid diet for 21 days (8.7%); elevated plus maze test 6 weeks after WD, with drug given 15 min before the test in combination with restraint stress or no stress	ICV D-Phe-CRF <sub>(12-41)</sub> (10 µg in 5 µl) attenuated anxiogenic effects of combined EtOH WD and restraint stress
	D-Phe-CRF <sub>(12-41)</sub>	Funk <i>et al.</i> (2006)	Wistar rats	Operant self-administration for ~25 days (10% EtOH; 30 min access), then intermittent EtOH vapor for 14 h/day for 4 weeks; then drug was infused 5 min before operant self-administration, which was examined 2 h after WD	Intra-CeA D-Phe-CRF <sub>(12-41)</sub> (0.125, 0.25 or 0.5 µg/µl) dose-dependently reduced EtOH seeking in dependent, but not in non-dependent, rats. This effect was absent for other brain regions (BNST and NAcc shell). CRF immunoreactivity was significantly reduced in CeA of EtOH-dependent and withdrawn rats, but not in other brain regions
	D-Phe-CRF <sub>(12-41)</sub>	Finn <i>et al.</i> (2007)	C57BL/6J mice	EtOH drinking; two-bottle DID for 2 h/day for 1 week (15% EtOH); EtOH vapor for 16 h/day for 4 days; then WD for 2 weeks, followed by 1 week of 15% EtOH access for 2 h/day and another 4-day vapor exposure; then 1 week of 15% EtOH drinking; the effect of drug was examined 15 min after infusion in a single drinking session	Intra-CeA D-Phe-CRF <sub>(12-41)</sub> (0.25 µg/0.5µl/side) decreased EtOH WD-induced increases in EtOH intake, compared with vehicle treatment; it had no effect on non-dependent controls
	D-Phe-CRF <sub>(12-41)</sub>	Bruijnzeel <i>et al.</i> (2010)	Wistar rats	EtOH liquid diet for 12 weeks (5.7% EtOH); drug given 15 min before intracranial self-stimulation test that occurred 8 h after EtOH WD	ICV D-Phe CRF <sub>(12-41)</sub> (10 or 20 µg in 5 µl) dose-dependently prevented the elevation of brain reward self-stimulation thresholds associated with EtOH WD
	D-Phe-CRF <sub>(12-41)</sub>	Le <i>et al.</i> (2013)	Wistar rats	EtOH drinking; two-bottle choice for 3 weeks; then operant EtOH self-administration for 3 weeks (12% EtOH; 1 h access); effect of D-Phe-CRF <sub>(12-41)</sub>	Yohimbine (1.25 mg/kg) increased active EtOH self-administration but intra-MRN D-Phe-CRF <sub>(12-41)</sub> (2.5 or 50 ng in 0.5 µl) had no effect. Intra-

Receptor, drug type	Drug	Reference	Model	Treatment or trait	Finding
CRF <sub>1</sub> , antagonist	LWH-63 (NIH-3)	Subino <i>et al.</i> (2006)	sP rats	<p>given 15 min before vehicle or yohimbine, was examined on active self-administration; effect also examined after extinction (5–9 days) to test reinstatement</p> <p>Study one: EtOH drinking; continuous access two-bottle choice for 3 weeks (10% EtOH); then limited access for 6 days (1 h/day); then operant EtOH self-administration training (10% EtOH, 30 min/day); vapor exposure for 14 h/day for 5–7 weeks; drug was given 1 h before self-administration session, which was initiated 6 h after EtOH WD</p> <p>Study two: EtOH drinking; continuous access two-bottle choice for 4 weeks (10% EtOH); then EtOH DID with 2 h/day EtOH access (10% EtOH) until stable; drug effect on EtOH intake assessed 1 h after treatment</p>	<p>MRN D-Phe-CRF<sub>(12-41)</sub> (25 or 50 ng in 0.5 µl) dose-dependently reduced yohimbine-induced reinstatement of EtOH seeking</p> <p>Study one: SC LWH-63 (5, 10 or 20 mg/kg) reduced WD-associated self-administration behavior in dependent rats, but had no effect on non-dependent rats</p> <p>Study two: LWH-63 (5, 10 or 20 mg/kg) increased both EtOH and water intake in the DID study</p>
	LWH-63	Lowery-Gionta <i>et al.</i> (2012)	C57BL/6J mice	EtOH drinking and BEC; single-bottle DID 2 h/day for 3 days, then 4 h on day 4 (20% EtOH); same procedure for 10% sucrose; also assessed drinking in the light using same procedure as above. Drug was given 30 min prior to EtOH access	IP LWH-63 (10, 30 or 60 mg/kg) dose-dependently attenuated DID EtOH consumption and BEC, but not sucrose intake or EtOH consumption in the light
CRF <sub>1</sub> , antagonist	Antalarmin	Lodge and Lawrence (2003)	Fawn-Hooded rats	Drug given on 3 days to examine effect on acquisition of EtOH drinking; two-bottle choice continuous access for 10 days (5% EtOH); drug then given twice daily for 10 days to examine effects on established EtOH drinking	IP Antalarmin (20 mg/kg) reduced the acquisition of EtOH drinking, and reduced established EtOH consumption
	Antalarmin	Hansson <i>et al.</i> 2006	msP and Wistar rats	Operant self-administration for 15 days (10% EtOH 30 min/day); extinction for 15 days; drug given 30 min before self-administration or footshock-induced reinstatement test	IP Antalarmin (10 or 20 mg/kg) dose-dependently attenuated EtOH lever pressing and blocked footshock-induced reinstatement of EtOH seeking in msP rats, but had no effect on Wistar rats
	Antalarmin	Chu <i>et al.</i> (2007)	C57BL/6J mice	Operant self-administration training, then EtOH vapor for 3 weeks (14 h/day); drug was given 1 h before self-administration session, which was assessed 10 days after WD	IP Antalarmin (30 mg/kg) blocked WD-induced increases in EtOH self-administration behavior (number of reinforcers)
	Antalarmin	Funk <i>et al.</i> (2007)	Wistar rats	Operant self-administration for ~25 days (10% EtOH; 30 min access), then intermittent EtOH vapor 14 h/day for 4 weeks; drug was given 1 h prior to operant self-administration session that was initiated 2 h after WD	IP Antalarmin (10 or 20 mg/kg) dose-dependently reduced WD-induced increases in EtOH lever presses in dependent rats; there was no effect on non-dependent rats
	Antalarmin	Marinelli <i>et al.</i> (2007)	Wistar rats	EtOH drinking; two-bottle choice EtOH continuous access for 20 days (3–12%	IP Antalarmin (10 or 20 mg/kg) dose-dependently attenuated

Receptor, drug type	Drug	Reference	Model	Treatment or trait	Finding
	Antalarmin	Yang <i>et al.</i> (2008)	129SVEV mice	EtOH; then operant EtOH self-administration for 1 h/day for ~16 days (12% EtOH); extinction for 13 days; reinstatement induced by yohimbine stress; antalarmin was given 15 min before yohimbine and EtOH self-administration was measured 45 min later	yohimbine (1.25 mg/kg) stressor-induced increases in EtOH self-administration behavior and intake, as well as yohimbine-induced reinstatement of EtOH seeking. Antalarmin had no effect on non-yohimbine-treated rats and no effect on yohimbine-induced CORT levels
	Antalarmin	Cippitelli <i>et al.</i> (2012)	Wistar rats	EtOH drinking; two-bottle choice continuous access for 11 days (3–12% EtOH); restraint stress twice daily for 60 min on days 4–7; drug given 30 min prior to each restraint stress	IP Antalarmin (20 mg/kg) did not block stress-induced increases in EtOH intake or EtOH intake in non-stressed mice
	Antalarmin	Lowery-Gionta <i>et al.</i> (2012)	C57BL/6J mice	EtOH drinking; two-bottle choice intermittent access (10% or 20% EtOH every other day for 24 h/day for 40 days and thus, 20 days of EtOH exposure) or continuous access (10% or 20% EtOH for 24 h/day for 20 days); drug given 30 min prior to EtOH access after the 20-day exposure period	IP Antalarmin (10 or 20 mg/kg) dose-dependently reduced EtOH intake in intermittent access condition for both 10% and 20% EtOH, but only for 20% EtOH in continuous access condition
	Antalarmin	Molander <i>et al.</i> (2012)	Wistar rats	EtOH drinking; two-bottle choice continuous access for 8 weeks (5–20% EtOH); the EtOH access removed for 3 weeks; antalarmin was given on five consecutive days and EtOH intake was measured for 1 week, beginning after the second injection	IP Antalarmin (30 mg/kg) attenuated DID EtOH consumption and BEC, but not EtOH consumption in the light; intra-CeA Antalarmin (1 µg in 0.5 µl, 1 h before EtOH access) attenuated DID EtOH consumption and BEC, but not sucrose consumption
	Antalarmin	Ayanwuyi <i>et al.</i> (2013)	msP rats with CRF point mutations associated with CRF over-expression (genotype AA or GG); Wistar rats	EtOH drinking; two-bottle choice continuous access for 15 days (10% EtOH), then operant self-administration until stable (10%, 30 min/day); antalarmin given 30-min prior to operant session or 30 min prior to yohimbine stress	IP Antalarmin (5, 10 or 20 mg/kg) reduced the number of EtOH-rewards earned in Wistar and msP-AA rats, but not in msP-GG rats; effect occurred at a lower dose in msP-AA than Wistar; IP Antalarmin (10 mg/kg) blocked the yohimbine-induced increase in EtOH-rewards earned in all three rat lines
CRF <sub>1</sub> antagonist	CP-154,526	Le <i>et al.</i> (2000)	Wistar rats	EtOH drinking; two-bottle choice intermittent access for 30 days (3–12% EtOH; 30 min/day); then operant self-administration for ~24 days (12% EtOH; 1 h/day); extinction for 5–8 days;	IP CP-154,526 (15, 30 or 45 mg/kg) dose-dependently attenuated footshock-induced reinstatement of EtOH seeking.

Receptor, drug type	Drug	Reference	Model	Treatment or trait	Finding
				treatment given 15 min prior to reinstatement session or 15 min prior to intermittent footshock, which was administered just before reinstatement session	There was no significant effect on the no-shock condition
	CP-154,526	Overstreet <i>et al.</i> (2004)	Sprague–Dawley rats	EtOH liquid diet for 15 days with 2 days of WD every 5 days (7% EtOH); drug given during the first two WD periods and social interaction measured 5 h after the final (third) EtOH WD	Social interaction is used to index anxiety-related behavior and is sensitive to EtOH WD and stress. IP CP-154,526 (10 mg/kg) blocked the repeated EtOH WD-associated reduction in social interaction
	CP-154,526	Overstreet <i>et al.</i> (2005)	P rats	EtOH liquid diet for 15 days with 2 days of WD every 5 days (4.5% EtOH); drug given during the first two WD periods and social interaction measured 5 h after the final (third) EtOH WD	Social interaction was used as a measure of behavioral change sensitive to EtOH WD and stress. IP CP-154,526 (10 mg/kg) blocked the repeated EtOH WD-associated reduction in social interaction
	CP-154,526	Breese <i>et al.</i> (2005b)	Sprague–Dawley rats	EtOH liquid diet for 15 days with 2 days of WD every 5 days (4.5% EtOH); drug given during the first two WD periods and social interaction measured 30 min after restraint stress applied three days after the final (third) WD; in another group drug was given 30 min prior to the restraint stress exposure	Social interaction is used to index anxiety-related behavior and is sensitive to EtOH WD and stress. IP CP-154,526 (10 mg/kg) attenuated the reduced social interaction induced by EtOH WD plus stress when given at either time point
	CP-154,526	Fee <i>et al.</i> (2007)	DBA/2J mice	EtOH-induced locomotor sensitization; acute test after IP 1.5 g/kg EtOH, then mice treated with IP 2.5 g/kg EtOH for 10 days, then challenge locomotor test performed after IP 1.5 g/kg EtOH; for acquisition study, drug was given 30 min prior to each 2.5 g/kg EtOH treatment; for expression study, drug was given 30 min prior to the final 1.5 g/kg EtOH challenge	IP CP-154,526 (5 or 10 mg/kg) had no effect on the acquisition of sensitization, but dose-dependently prevented the expression of EtOH-induced locomotor sensitization
	CP-154,526	Overstreet <i>et al.</i> (2007)	P rats	EtOH drinking: two-bottle choice continuous access for 15 days with 2 days of WD every 5 days (10% EtOH); drug given 30 min before a 1 h restraint stress applied during the first two EtOH WD periods; social interaction measured 5 h after the final (third) EtOH WD	Social interaction is used to index anxiety-related behavior and is sensitive to EtOH WD and stress. IP CP-154,526 (10 mg/kg) reduced the increase in EtOH intake seen after repeated EtOH WD and stress; it also attenuated the reduced social interaction seen after repeated EtOH WD and stress
	CP-154,526	Lowery <i>et al.</i> (2008)	C57BL/6N and BALB/cJ mice	EtOH drinking: two-bottle choice continuous access for 16 days (2–8% EtOH); then drug given 30 min before 5-min forced swim stress, followed by EtOH intake measured for 4 weeks	IP CP-154,526 (10 mg/kg) blunted swim stress-induced increased EtOH intake in BALB/cJ mice, with no significant effect on non-stressed mice. Swim stress did not alter EtOH intake in C57BL/6N mice



Receptor, drug type	Drug	Reference	Model	Treatment or trait	Finding
	CP-154,526	Pastor <i>et al.</i> (2008)	DBA/2 J mice	EtOH-induced locomotor sensitization; IP 1.5 g/kg EtOH once daily for 10 days, then 1.5 g/kg EtOH challenge and locomotor test; for acquisition study, drug was given 30 min prior to each 1.5 g/kg EtOH treatment except on the final challenge day; for expression study, drug was given 30 min prior to the final 1.5 g/kg EtOH challenge only	IP CP-154,526 (15 or 30 mg/kg, dose-dependently attenuated the acquisition of sensitization and prevented the expression of EtOH-induced locomotor sensitization
	CP-154,526	Sparta <i>et al.</i> (2008)	C57BL/6J mice	EtOH drinking: single-bottle DID 4 h/day for all 4 days or 2 h/day on days 1–3 and then 4 h on day 4 (20% EtOH); drug given 30 min before EtOH access on day 4; sucrose consumption using the same 2 h/4 h procedure	IP CP-154,526 (1, 3 or 10 mg/kg) reduced EtOH intake in the 2-h then 4 h DID, but not in the all 4-h DID procedure; sucrose consumption was not affected
	CP-154,526	Sparta <i>et al.</i> (2009)	C57BL/6J mice	Operant self-administration for 2 weeks to establish stable responding (2–10% EtOH 16 h/day); EtOH was also available in the home cage; 4-day EtOH deprivation period, then drug 30 min before 2 h operant session	IP CP-154,526 (10 or 20 mg/kg) dose-dependently blocked EtOH deprivation-induced increase in EtOH-associated lever responding and EtOH intake; there were also effects at some doses on water responding and consumption
	CP-154,526	Wills <i>et al.</i> (2009)	Sprague-Dawley rats; adult and adolescent	EtOH liquid diet for 15 days with 2 days of WD every 5 days (2.5% or 3.5% EtOH); drug given 4 h after WD during the first two WD periods; social interaction measured 5 h after the final (third) EtOH WD	Social interaction is used to index anxiety-related behavior and is sensitive to EtOH WD and stress. IP CP-154,526 (10 mg/kg) attenuated the reduced social interaction induced by repeated EtOH WD
	CP-154,526	Lowery <i>et al.</i> (2010)	C57BL/6J mice	EtOH drinking: single-bottle DID for 3 days, then for 4 h on day 4 (20% EtOH, 2 h/day); drug given 60 min before day 4 EtOH access; adrenalectomy or sham surgery	IP CP-154,526 (10 or 15 mg/kg) dose-dependently reduced EtOH intake and BEC in both sham and adrenalectomized mice
	CP-154,526	Hwa <i>et al.</i> (2013)	C57BL/6J mice; Long Evans rats	EtOH drinking; two-bottle choice for 4 weeks, 3 days a week (20% EtOH, 24 h/day); for one study, mice were given continuous daily EtOH access for similar period (20% EtOH, 24 h/day); drug infused 10 min before measuring EtOH drinking	Intra-VTA and intra-DRN CP-154,526 (0.3 or 0.6 µg) dose-dependently decreased EtOH intake in both mice and rats, under both drinking conditions; there were also some effects on water intake
	CP-154,526	Sparta <i>et al.</i> (2013)	C57BL/6J mice	EtOH drinking: single-bottle DID 2 h/day on days 1–3 and then 4 h on day 4 (20% EtOH); drug infused 30 min before EtOH access on day 4; also sucrose consumption using the 2 h/4 h procedure; electrophysiology in slice preparation	Intra-VTA CP-154,526 (1 µg, 0.5 µl/side) reduced EtOH intake; DID enhanced CRF-mediated potentiation of VTA DA neuron <i>N</i> -methyl-D-aspartate receptor currents; this effect was blocked by CP-154,526

Receptor, drug type	Drug	Reference	Model	Treatment or trait	Finding
CRF <sub>1</sub> , antagonist	CP-376,395	Giardino and Ryabinin (2013)	C57BL/6J mice	EtOH drinking: two-bottle DID 2 h/day for 3 days, then for 4 h on day 4 (15% EtOH); also sucrose consumption using the same procedure; water and food intake; drug was given 30 min prior to measurements	IP CP-376,395 (10 or 20 mg/kg) reduced EtOH intake and food intake; it increased sucrose intake
	CP-376,395	Simms <i>et al.</i> (2014)	Long Evans rats	EtOH drinking: two-bottle choice continuous access every day or every other day for 9 weeks (20% EtOH); drug given 30 min prior to drinking session	IP CP-376,395 (5 or 10 mg/kg) reduced EtOH intake in every other day access, but not in every day access, condition
CRF <sub>1</sub> , antago	list CRA-1000	Breese <i>et al.</i> (2004)	Sprague-Dawley and P. rats	Restraint stress for 1 h on days 6 and 11 (on control diet) and then 4.5% EtOH liquid diet for 5 days; social interaction measured 5 h after WD; drug given 30 min prior to each restraint stress	Social interaction is used to index anxiety-related behavior and is sensitive to EtOH WD and stress. IP CRA-1000 (3 mg/kg) attenuated the reduced social interaction induced by stress in EtOH WD rats
	CRA1000	Knapp <i>et al.</i> (2004)	Sprague-Dawley rats	EtOH liquid diet for 17 days (7% EtOH); drug given 30 min before social interaction test which was administered 5–6 h after WD	Social interaction is used to index anxiety-related behavior and is sensitive to EtOH WD and stress. IP CRA1000 (0.25, 0.5 or 1 mg/kg) dose-dependently attenuated the decrease in social interaction seen during EtOH WD without altering locomotor activity
	CRA1000	Overstreet <i>et al.</i> (2004)	Sprague-Dawley rats	EtOH liquid diet for 15 days with 2 days of WD every 5 days (7% EtOH); drug given 4 h after EtOH WD during the first two WD periods and social interaction measured 5 h after the final (third) EtOH WD; in another group, drug given only 30 min before social interaction test	Social interaction was used to measure a behavioral change associated with EtOH exposure and WD. IP CRA1000 (3 mg/kg) given during the first two WD periods blocked the repeated EtOH WD-associated reduction in social interaction. IP CRA1000 (1 mg/kg) given prior to the social interaction test also blocked this effect of EtOH WD
	CRA1000	Overstreet <i>et al.</i> (2007)	P rats	EtOH drinking: two-bottle choice continuous access for 15 days with 2 days of WD every 5 days (10% EtOH); drug given 30 min before a 1 h restraint stress applied during the first two EtOH WD periods; social interaction measured 5 h after the final (third) EtOH WD	Social interaction is used to index anxiety-related behavior and is sensitive to EtOH WD and stress. IP CRA1000 (3 mg/kg) reduced the increase in EtOH intake seen after repeated EtOH WD and stress; it also attenuated the reduced social interaction seen after repeated EtOH WD and stress
CRF <sub>1</sub> , antagonist	MJL-1-109-2	Funk <i>et al.</i> (2007)	Wistar rats	Operant self-administration for ~25 days (10% EtOH; 30 min/day), then intermittent EtOH vapor 14 h/day for 4 weeks; drug was given 1 h prior to operant self-administration session that was initiated 2 h after WD	IP MJL-1-109 (0.6, 1.25 or 5 mg/kg) dose-dependently reduced WD-induced increases in EtOH lever presses in dependent rats; there was no effect on non-dependent rats

Receptor, drug type	Drug	Reference	Model	Treatment or trait	Finding
	MJL-1-109-2	Sabino <i>et al.</i> (2006)	sP rats	EtOH drinking; two-bottle choice continuous access for 4 weeks (10% EtOH); drug effect on EtOH intake assessed 1 h after treatment	IP MJL-1-109 (1.25, 2.5 or 10 mg/kg) had not effect on EtOH intake
CRF <sub>1</sub> , antagonist	MPZP	Gilpin <i>et al.</i> 2008	P rats	Operant self-administration for ~25 days (10% EtOH; 30 min/day), then intermittent EtOH vapor for 10 weeks (14 h/day); drug was given 1 h before operant self-administration, which was examined 6 h after WD	SC MPZP (5, 10 or 20 mg/kg) attenuated WD-induced increases in EtOH lever presses and intake in dependent rats; there was no effect on non-dependent rats
	MPZP	Ji <i>et al.</i> (2008)	Wistar rats	Two-bottle choice sweetened EtOH DID for 9 days (10% EtOH in 'supersac', 30 min/day); also operant sweetened EtOH self-administration for 17 days (10% EtOH, 30 min/day); then drug given 1 h prior to subsequent drinking or operant session	SC MPZP (5, 10 or 20 mg/kg) had no effect on two-bottle choice sweetened EtOH intake; a small increase in sweetened EtOH intake was seen with increasing dose of SC MPZP in the operant study
	MPZP	Richardson <i>et al.</i> (2008b)	Wistar rats	Operant self-administration for ~3 weeks (10% EtOH; 30 min/day), then intermittent EtOH vapor for 4 weeks (14 h/day); drug was given 1 h before operant session, which was initiated 6–8 h after WD	SC MPZP (5, 10 or 20 mg/kg) reduced increased EtOH intake associated with EtOH WD, but did not affect EtOH intake in non-dependent rats
CRF <sub>1</sub> , antagonist	MTTP	Gehlert <i>et al.</i> (2007)	Sprague–Dawley, Wistar and msP rats	Operant self-administration for 15 days (10% EtOH, 30 min/day); after self-administration established, EtOH by gavage for 6 days to induce dependence in one group of Wistar rats (9–12 g/kg/day); then drug was given 30 min before self-administration session; extinction over 15 days and then drug effect on footshock-induced reinstatement	IP MTTP (3, 10 or 20 mg/kg) reduced EtOH self-administration and reinstatement of EtOH seeking in msP rats, and in EtOH-dependent, but not non-dependent, Wistar rats
	MTTP	Sommer <i>et al.</i> (2008)	Wistar rats	Intermittent EtOH vapor for 7 weeks (17 h/day); drug given 30 min prior to Vogel conflict test of punished drinking, which was examined 13 weeks after WD	IP MTTP (10 mg/kg) eliminated fear suppression of behavior in the Vogel conflict test in rats with and without a history of EtOH dependence
CRF <sub>1</sub> , antagonist	NBI-27914	Lowery-Gionta <i>et al.</i> (2012)	C57BL/6J mice	EtOH drinking and BEC; single-bottle DID 2 h/day for 3 days, then 4 h on day 4 (20% EtOH); same procedure for 10% sucrose; also assessed drinking in the light using same procedure as above, drug was given 30 min prior to EtOH access	IP NBI-27914 (10, 30 or 60 mg/kg) dose-dependently attenuated DID EtOH consumption and BEC, but not sucrose intake or EtOH consumption in the light
	NBI-27914	Molander <i>et al.</i> (2012)	Wistar rats	EtOH drinking; two-bottle choice continuous access for 8 weeks (5–20% EtOH); then EtOH access removed for 3 weeks; antalarmin was given on 5 consecutive days and EtOH intake was	IP NBI-27914 (10 mg/kg) did not alter increased EtOH intake seen after the EtOH deprivation period

Receptor, drug type	Drug	Reference	Model	Treatment or trait	Finding
	NBI-27914	Giardino and Ryabinin (2013)	C57BL/6J mice	measured for 1 week, beginning after the second injection EtOH drinking; two-bottle DID 2 h/day for 3 days, then for 4 h on day 4 (15% EtOH); also sucrose consumption using the same procedure; water and food intake; drug was given 30 min prior to measurements	IP NBI-27914 (10 or 30 mg/kg) reduced EtOH, food and saccharin intake
CRF <sub>1</sub> , antagonist	R121919	Sabino <i>et al.</i> (2006)	sP rats	Study one: Two-bottle choice continuous access (10% EtOH) for 4 weeks; drug effect on EtOH intake assessed 1 h after treatment Study two: Two-bottle choice as described above; then 2 h/day EtOH access (10% EtOH) until stable; drug effect on DID EtOH intake assessed 1 h after treatment Study three: same as Study two and then drug treated prior to novelty stress and then EtOH intake measured 1 h after drug	Study one: SC R121919 (10 mg/kg) had no effect on continuous access EtOH intake Study two: SC R121919 (5, 10 and 20 mg/kg) increased DID EtOH intake. Study three: SC R121919 (10 mg/kg) attenuated novelty stress-induced suppression of EtOH intake
	R121919	Funk <i>et al.</i> (2007)	Wistar rats	Operant self-administration for ~25 days (10% EtOH; 30 min access), then intermittent EtOH vapor 14 h/day for 4 weeks; drug was given 1 h prior to operant self-administration session that was initiated 2 h after WD	SCR121919 (5, 10 or 20 mg/kg) dose-dependently reduced WD-induced increases in EtOH lever presses in dependent rats; there was no effect on non-dependent rats
	R121919	Yang <i>et al.</i> (2008)	129SVEV mice	EtOH drinking; two-bottle choice continuous access for 11 days (3–12%); restraint stress twice daily for 60 min on days 4–7; drug given 30 min prior to each restraint stress	IP R121919 (15 or 20 mg/kg) did not block stress-induced increases in EtOH intake or EtOH intake in non-stressed mice
	R121919	Roberto <i>et al.</i> (2010)	Sprague-Dawley rats	Operant self-administration for ~25 days (10% EtOH; 30 min/day), then intermittent EtOH vapor for 2–4 weeks (14 h/day); EtOH self-administration measured during this time, with drug given repeatedly on even numbered days and self-administration tested on odd numbered days; GABA neurotransmission; brain slice electrophysiology; <i>in vitro</i> microdialysis	Chronic SC R121919 (10 mg/kg) blocked the development of EtOH-dependence-induced increases in EtOH intake and also reduced EtOH intake in non-dependent rats; <i>in vitro</i> R121919 decreased basal GABAergic responses and blocked EtOH-induced increases in GABA transmission. SC R121919 decreased EtOH-induced increases in dialysate GABA in the CeA in both EtOH-dependent and non-dependent rats
	R121919	Lee <i>et al.</i> (2013)	C57BL/6J mice	Acute functional tolerance to ataxic effects of EtOH (IP 2 g/kg) (time of R121919 treatment unclear)	R121919 reduced the rate of recovery and the development of acute functional tolerance to the ataxic effects of EtOH

Receptor, drug type	Drug	Reference	Model	Treatment or trait	Finding
	R121919	Sabino <i>et al.</i> (2013)	sP rats	EtOH drinking; two-bottle choice continuous access for 7 weeks, every day (10% EtOH) or every other day (20% EtOH); then drug given 45 min before drinking test	SC R121919 (5, 10 or 20 mg/kg) had no effect on EtOH intake in either condition
	R121919	Roltsch <i>et al.</i> (2014)	Wistar rats	EtOH drinking; two-bottle choice continuous access for 1 day (10% EtOH), then operant self-administration for ~15 days (10% EtOH, 30 min/day); effect of drug given 2, 5, 8, 12, 15 and 19 days after predator odor stress on stress-induced increase in EtOH self-administration, measured 60 min after drug treatment	SC R121919 (10 mg/kg) reduced the increased EtOH intake seen in predator odor stress-exposed rats; the effect was not dependent on day
CRF <sub>1</sub> , antagonist	SSR125543	Huang <i>et al.</i> (2010)	Sprague–Dawley rats	SSR125543 given 15 min before CRF or restraint stress on days 2 days, one week apart, while on control diet, then EtOH liquid diet for 5 days (4.5% EtOH); social interaction test and locomotor activity assessed 5 h after EtOH WD	Social interaction is used to index anxiety-related behavior and is sensitive to EtOH WD and stress. IP SSR-125543 (10 mg/kg) given prior to CRF or restraint stress (see Huang <i>et al.</i> 2010 entry above for CRF) prevented CRF-associated and stress-associated exacerbated reductions in social interactions seen in EtOH WD rats
	SSR125543	Knapp <i>et al.</i> (2011a)	Inbred Alcohol-preferring (iP) rats	EtOH drinking; single-bottle continuous access for 3 days (10% EtOH) then two-bottle choice continuous access for 15 days or 15 days with 2 days of WD every 5 days (10% EtOH); drug given 15 min before a 1 h restraint stress (or without stress) applied during the first two EtOH WD periods; drinking examined in subsequent 5-day periods; social interaction measured 5–6 h after the final (third) EtOH WD	Social interaction is used to index anxiety-related behavior and is sensitive to EtOH WD and stress. Intra-NAcc SSR125543 (10 µg/0.5 µl) prevented stress and EtOH WD-associated increased EtOH intake, but not reduced social interaction seen in these rats; intra-amygdala or DRN SSR125543 prevented stress and WD effects on social interaction, but did not prevent the increase in EtOH intake
	SSR125543	Knapp <i>et al.</i> (2011b)	Sprague–Dawley rats	SSR125543 given 15 min before cytokine or chemokine treatment 2 days, 1 week apart, while on control diet, then EtOH liquid diet for 5 days (4.5% or 7% EtOH); social interaction test and locomotor activity assessed 5 h after EtOH WD	Social interaction is used to index anxiety-related behavior and is sensitive to EtOH WD and stress. IP SSR125543 (10 mg/kg) given prior to the cytokine reversed the reduced social interaction time seen in cytokine- and chemokine-treated animals after EtOH WD
CRF <sub>2</sub> , agonist	Ucn <sub>3</sub>	Valdez <i>et al.</i> (2004)	Wistar rats	Operant self-administration for ~22 days (5–10%, 30 min/day); then EtOH liquid diet for 21 days (10%); drug given and self-administration and elevated plus maze behavior assessed 2 h after EtOH WD; drug was infused 10 min before the	ICV Ucn <sub>3</sub> (1 or 10 µg) attenuated anxiety-like behavior induced by WD from chronic liquid EtOH diet; ICV Ucn <sub>3</sub> (1 or 10 µg) reduced increased EtOH lever presses associated with repeated EtOH WD. It had no significant effect on

Receptor, drug type	Drug	Reference	Model	Treatment or trait	Finding
	Ucn <sub>3</sub>	Funk and Koob (2007)	Wistar rats	5-min plus maze test or just before the operant test Operant self-administration (10% EtOH for ~25 days; 30 min access), then EtOH vapor (intermittent for 14 h/day for 4 weeks); then effect of drug on operant EtOH self-administration 2 h after WD	control group animals in either study Intra-CeA Ucn <sub>3</sub> (0.02, 0.1, or 0.5 µg/µl) dose-dependently decreased EtOH lever presses in dependent rats; a small increase in EtOH lever presses was seen at the highest concentration of Ucn <sub>3</sub> in non-dependent rats; there was no effect on lever pressing for water
	Ucn <sub>3</sub>	Sharpe and Phillips (2009)	C57BL/6J mice	EtOH drinking; two-bottle choice DID for ~40 days (10% EtOH); drug treatment occurred immediately before a drinking session	ICV Ucn <sub>3</sub> (0.3, 1 or 3 nmol in 1–2 µl) dose-dependently reduced EtOH intake
	Ucn <sub>3</sub>	Huang <i>et al.</i> (2010)	Sprague–Dawley rats	EtOH liquid diet (4.5% EtOH) for 5 days; social interaction test and locomotor activity assessed 5 h after EtOH WD	Social interaction is used to index anxiety-related behavior and is sensitive to EtOH WD and stress. ICV Ucn <sub>3</sub> (5 µg in 5 µl) or Ucn <sub>3</sub> (0.5 µg/site in 0.5 µl) infused into several brain regions did not affect social interaction in repeated EtOH WD or non-dependent rats. Locomotor activity was not affected
CRF <sub>2</sub> antagonist	Ucn <sub>3</sub>	Lowery <i>et al.</i> (2010)	C57BL/6J mice	EtOH drinking; sucrose drinking; single-bottle DID (20% EtOH 2 h/day for 3 days, then for 4 h on day 4; same procedure for 10% sucrose); drug given 90 min before day 4 EtOH or sucrose access; BEC	ICV Ucn <sub>3</sub> (0.05, 0.1 or 0.5 µg in 1 µl) dose-dependently reduced EtOH intake and BEC. Sucrose consumption was not affected
	Antisauvagine-30	Overstreet <i>et al.</i> (2004)	Sprague–Dawley rats	EtOH liquid diet (7% EtOH for 15 days with 2 days of WD every 5 days); drug given 4 h after EtOH WD during the first two WD periods and social interaction measured 5 h after the final (third) EtOH WD	Social interaction is used to index anxiety-related behavior and is sensitive to EtOH WD and stress. ICV Antisauvagine-30 (20 µg) had no effect on repeated EtOH WD-induced reductions in social interaction
	Antisauvagine-30	Weitemier and Ryabinin (2006)	C57/BL6J mice	EtOH drinking (2.5 and then 5%) for 1 week; two-bottle choice continuous access; then cannulation surgery; then re-establishment of EtOH drinking (5%)	Intra-DR Antisauvagine-30 (100 pmol) did not affect EtOH, food or total fluid intake, during a 14-h period, beginning 2 h after treatment
Grand mineralocorticoid receptor, agonist	CORT	Fahlke <i>et al.</i> (1996)	Wistar rats	EtOH drinking; two-bottle choice continuous access for 14 days (2–6% EtOH), then two-bottle choice at 6% EtOH for 3 weeks; adrenalectomy; CORT given for 2 weeks (3 times/week), during which time EtOH consumption was measured	Adrenalectomy decreased EtOH intake; ICV CORT (100 µg) restored EtOH intake; SC CORT (100 µg) did not restore EtOH intake; non-adrenalectomized individual rats with lower EtOH intake showed elevated intake after ICV (100 µg) CORT



Receptor, drug type	Drug	Reference	Model	Treatment or trait	Finding
	CORT	O'Callaghan <i>et al.</i> (2005)	High preference and low preference mice	EtOH drinking; 24-h two-bottle choice (8% EtOH) for 3 weeks to establish drinking, then treatment effects were examined	IP CORT (20 mg/kg, once daily for 7 days) did not affect EtOH preference in low preference mice; high preference mice were not studied
	CORT	Yang <i>et al.</i> (2008)	129SVEV and C57BL/6J mice	Two-bottle choice continuous access EtOH drinking (3-12% for 7 days); mice were adrenalectomized and given CORT replacement (10 mg concentration pellet) prior to EtOH drinking	Both strains of mice with higher CORT levels (>100 ng/ml) showed reduced EtOH consumption, compared with sham plus placebo and those with lower CORT levels (<100 ng/ml)
	CORT	Pastor <i>et al.</i> (2012)	DBA/2J mice	CORT-induced locomotor sensitization to EtOH (IP 1.5 g/kg)	Repeated IP CORT (10 or 20 mg/kg once daily for 10 days) induced sensitization to the locomotor stimulant effect of EtOH
Blocks CORT synthesis	Metyrapone	O'Callaghan <i>et al.</i> (2005)	High preference and low preference mice	EtOH drinking; 24-h two-bottle choice (8% EtOH) for 3 weeks to establish drinking, then treatment effects were examined	IP metyrapone (100 mg/kg, twice daily for 7 days) reduced EtOH preference in high preference mice and prevented increases in EtOH preference over time that were seen in low preference mice injected with vehicle
	Metyrapone	Lowery <i>et al.</i> (2010)	C57BL/6J mice	EtOH drinking; sucrose drinking; single-bottle DID (20% EtOH 2 h/day for 3 days, then for 4 h on day 4; same procedure for 10% sucrose); drug given 30 min before day 4 EtOH or sucrose access; BEC	IP Metyrapone (50, 100 or 150 mg/kg) dose-dependently reduced EtOH intake, BEC and sucrose intake
	Metyrapone	Pastor <i>et al.</i> (2012)	DBA/2J mice	EtOH-induced locomotor sensitization; IP 1.5 g/kg EtOH once daily for 10 days, then IP 1.5 g/kg EtOH challenge and locomotor test; for acquisition study, drug was given 30 min prior to each 1.5 g/kg EtOH treatment except on the final challenge day; for expression study, drug was given 30 min prior to the final 1.5 g/kg EtOH challenge only; CORT levels	IP Metyrapone (25 or 50 mg/kg) blocked the acquisition of sensitization and reduced EtOH-induced increases in CORT. IP Metyrapone (25 or 50 mg/kg) did not block the expression of sensitization
GR, antagonist	Mifepristone (RU486)	Roberts <i>et al.</i> (1995)	DBA/2J mice	EtOH-induced locomotor sensitization; IP 1.5 g/kg EtOH once daily for 10 days, then 1.5 g/kg EtOH challenge and locomotor test; drug given 30 min before each EtOH treatment except the final challenge treatment	IP Mifepristone (20 mg/kg) attenuated the acquisition of EtOH-induced sensitization
	Mifepristone	Koenig and Olive (2004)	Long Evans rats	EtOH drinking; two-bottle choice limited access for 5 days/week (10% EtOH); drug was given just before a 1 h access session	IP Mifepristone (1, 5 or 20 mg/kg) dose-dependently reduced EtOH, but not water, intake
	Mifepristone	Yang <i>et al.</i> (2008)	129SVEV	Two-bottle choice continuous access EtOH drinking (3-12% for 11 days); restraint stress twice daily for 60 min on	IP Mifepristone (25 or 50 µg/kg) did not block stress-induced increases in EtOH intake or EtOH intake in non-stressed mice

Receptor, drug type	Drug	Reference	Model	Treatment or trait	Finding
	Mifepristone	Pastor <i>et al.</i> (2008)	DBA/2J mice	days 4–7; drug given 30 min prior to each restraint stress EtOH-induced locomotor sensitization; IP 1.5 g/kg EtOH once daily for 10 days, then IP 1.5 g/kg EtOH challenge and locomotor test; drug given 30 min prior to the EtOH challenge test	IP Mifepristone (10 or 20 mg/kg) did not prevent the expression of EtOH-induced locomotor sensitization
	Mifepristone	Lowery <i>et al.</i> (2010)	C57BL/6J mice	EtOH drinking; single-bottle DID (20% EtOH 2 h/day for 3 days, then for 4 h on day 4); drug given 30 min before day 4 EtOH access; BEC	IP Mifepristone (25, 50 and 100 mg/kg) did not affect EtOH intake
Mineralocorticoid receptor, antagonist	Spirolonactone	Koenig and Olive (2004)	Long Evans rats	EtOH drinking; two-bottle choice limited access for 5 days/week (10% EtOH); drug was given just before a 1 h access session	IP Spirolonactone (10, 25 or 50 mg/kg) had no effect on EtOH or water intake
	Spirolonactone	Pastor <i>et al.</i> (2012)	DBA/2J mice	EtOH-induced locomotor sensitization; IP 1.5 g/kg EtOH once daily for 10 days, then 1.5 g/kg EtOH challenge and locomotor test; for acquisition study, drug was given 30 min prior to each 1.5 g/kg EtOH treatment except on the final challenge day; for expression study, drug was given 30 min prior to the final 1.5 g/kg EtOH challenge only	IP Spirolonactone (15 or 30 mg/kg) did not prevent acquisition of sensitization or block the expression of sensitization
GR, antagonist plus mineralocorticoid receptor, antagonist	Mifepristone plus RU28318	Bluhke <i>et al.</i> (1996)	Wistar rats	EtOH drinking; two-bottle choice continuous access for 14 days (2–6% EtOH), then two-bottle choice at 6% EtOH for ~3 weeks; drugs given for 2 weeks (three times/week), during which time EtOH drinking was assessed	ICV mifepristone (0.1 then 250 µg) plus RU28318 (0.1 then 250 µg) did not affect EtOH intake

BEC, blood ethanol concentration; DRN, dorsal raphe nucleus; EEG, electroencephalogram; IP intraperitoneal; MPZP *N,N*-bis(2-methoxyethyl)-3-(4-methoxy-2-methylphenyl)-2,5-dimethyl-pyrazolo[1,5-*a*]pyrimidin-7-amine; MRN, median raphe nucleus; MTIP3-(4-chloro-2-morpholin-4-yl-thiazol-5-yl)-8-(1-ethylpropyl)-2,6-dimethyl-imidazo[1,2-*b*]pyridazine; SC, subcutaneous; WD, withdrawal