

The Hera Milani Mission

M.Cardi⁽¹⁾ (presenting author), M.Pavoni⁽¹⁾, D.Calvi⁽¹⁾, A.Zanotti⁽¹⁾, F. Corradino⁽¹⁾, E.Sanguineti⁽¹⁾, F.Nichele⁽¹⁾, F.Topputo⁽²⁾, F.Ferrari⁽²⁾, C.Giordano⁽²⁾, F.Piccolo⁽²⁾, A.Rizza⁽²⁾, L.Sterpone⁽³⁾, S.Azimi⁽³⁾, Milani Consortium members and partners⁽⁴⁾ F.Perez Lissi⁽⁵⁾, P.Martino⁽⁵⁾, I.Carnelli⁽⁵⁾

⁽¹⁾ Tyvak International srl, Via Orvieto 19, 10149 Torino (TO), Italy. Ph +39 011 1911607
(margherita@tyvak.eu)

⁽²⁾ Politecnico di Milano (Italy), Department of Aerospace Science and Technology. Via La Masa 34, 20156, Milan, Italy. Ph: +39-02-2399-8351/7157 (francesco.topputo@polimi.it)

⁽³⁾ Politecnico di Torino-DAUIN (Italy), C.so Duca degli Abruzzi 24, 10129 Torino (ITALY), Ph +39.011.090.7009 (luca.sterpone@polito.it)

⁽⁴⁾ Centro Italiano Ricerche Aerospaziali (Italy), Altec Space (Italy), VTT (Finland), Huld (Finland), Kuva Space (Finland), Brno University of Technology (Czech Republic), University of Helsinki (Finland), Institute of Geology of the Czech Academy of Sciences (Czech Republic), Istituto Nazionale di Astrofisica (Italy), Technology for Propulsion and Innovation (Italy)

⁽⁵⁾ European Space Agency, Keplerlaan 1, 2201 AZ Noordwijk, the Netherlands, Ph +31 71 565 6565 (franco.perez.lissi@esa.int)

Abstract

Hera is the European part of the Asteroid Impact & Deflection Assessment (AIDA) international collaboration with NASA who is responsible for the DART (Double Asteroid Redirection Test) kinetic impactor spacecraft. Hera will be launched in October 2024 and will arrive late 2026. The Hera mothercraft will accommodate two 6U CubeSat, one of which is Milani, named after Professor Andrea Milani, for his unique contribution to asteroid science and visionary role in defining a viable planetary defence technique. The Milani CubeSat is developed by Tyvak International leading a consortium of European Universities, Research Centers and Firms from Italy, Czech Republic, Finland. During the cruise to the Asteroid (+2 years), Milani CubeSat will be hosted inside the Hera mothercraft, periodically checked for health and charged. At arrival it will be deployed and commissioned while Hera is performing the Dydimos detailed characterization phase, at about 10 to 20 km distance from the asteroid. Milani mission objectives are defined to add scientific value to the Hera mission: i) Map the global asteroid composition, ii) Characterize the asteroid surface, iii) Evaluate DART impacts effects on asteroid and support gravity field determination, iv) Characterize dust clouds around the asteroid, enhancing the scientific return of the whole Hera mission. The instruments supporting the mission are “ASPECT” (VTT, Finland), a SWIR, NIR and VIS imaging spectrometer and the “VISTA” (INAF, Italy), a thermogravimeter characterizing dust particles below 10 μ m.

1 Introduction

In 2026, the Hera spacecraft will rendezvous with the binary asteroid 65803 Didymos as the European contribution to the AIDA (Asteroid Impact and Deflection Assessment) international collaboration. NASA is responsible for the Double Asteroid Redirection Test (DART) mission, which successfully

impacted the asteroid in September 2022. Hera and DART have been conceived to be mutually independent, however, their value is increased when combined. Indeed, Hera is a planetary defense mission aimed to investigate the effect of DART impact, with clear scientific objectives as a bonus. In proximity of the target, Hera will release two 6U CubeSats, one of them is called Milani, in honor of professor Andrea Milani, for his unique contribution to asteroid science and visionary role in defining a viable planetary defence technique. The two nanosatellites will be the first CubeSats to orbit in the close proximity of a small body and the first to perform scientific and technological operations around a binary asteroid.

Tyvak International is responsible for the Hera Milani development and is leading (as Prime Contractor) a large consortium made by 10+ entities from Italy, Czech Republic and Finland. Milani will contribute to the scientific value of the Hera planetary defense mission, mainly through the visual inspection of the asteroid (main payload: ASPECT) and dust detection (secondary payload: VISTA).

2 Mission Objectives

Milani scientific phases design has been mostly driven by its main payload, ASPECT, a hyperspectral camera, equipped with a visible to near-infrared hyperspectral imager and will be used on Milani to perform global mapping of the asteroids with detailed observation of the DART crater on Dimorphos. ASPECT main scientific goals can be summarized in three actions:

- Imaging both the asteroids with a spatial resolution better than 2 m/pixel
- Imaging the secondary asteroid with a spatial resolution better than 1 m/pixel
- Imaging the DART crater with a spatial resolution better than 0.5 m/pixel at phase angle (Sun-asteroid-Milani angle) in the range [0-10] deg and [30-60] deg.

In terms of trajectory design, spatial resolution requirements drive the maximum range at which scientific observations can be performed.

From an operational point of view, Milani's communication with ground will be performed via Inter-Satellite Link (ISL) using Hera as data relay. For this reason, data downlink and uplink must be performed within the same communication windows used by Hera. Operations will be scheduled considering:

- Hera mission operations requirements
- Milani CubeSat mission operations requirements
- Mission Data downlink (Milani-to-Hera)
- Communication window (Hera-to-Earth)

In order to avoid open-loop manoeuvres, Milani needs to select the manoeuvring frequency to be as close as possible to Hera's pattern (4-3 days). This is not mandatory, however, it ensures the compatibility of the strategy with the requirement on the Turn-Around time (TAT)¹ of 48 h.

Scientific goals and operational constraints are the results of an initial phase of requirements definition and consolidations, led by Politecnico di Torino team and have been the main driver for the detailed design of the main phases of Milani's mission: Far Range Phase (FRP) and Close Range Phase (CRP). The scientific goals that mostly drove the mission design of Milani have been derived from its main payload, ASPECT, presented in the following sections.

3 Mission Profile and Concept of Operations (ConOps)

The Milani Mission is designed by Politecnico di Milano (PoliMI). Milani trajectory design has been mainly driven by the main scientific goals of the mission, but it has also been influenced by both technical and operational constraints. Due to the low gravity environment around the asteroids, selecting Keplerian orbits as nominal trajectories would require a demanding station keeping strategy

to counteract the SRP effect. For this reason, a patched-arc manoeuvring strategy that leverage the SRP acceleration to target pre-selected waypoints has been implemented. This strategy has flight heritage in small-body environment. It is the one currently envisaged by the Hera spacecraft during its operational phases and previously performed by the Rosetta spacecraft during its initial scientific phase, after rendezvous with comet 67-P/Churyumov-Gerasimenko. The waypoints selection has been mostly influenced by the passive nature of Milani's payload as well by the on-board navigation strategy, which force the CubeSat to avoid the night-side. The resulting trajectories are loop orbits with manoeuvres points placed as far away from each other as possible to maximize the time spent in proximity to the system.

Main Milani mission phases are hereafter presented:

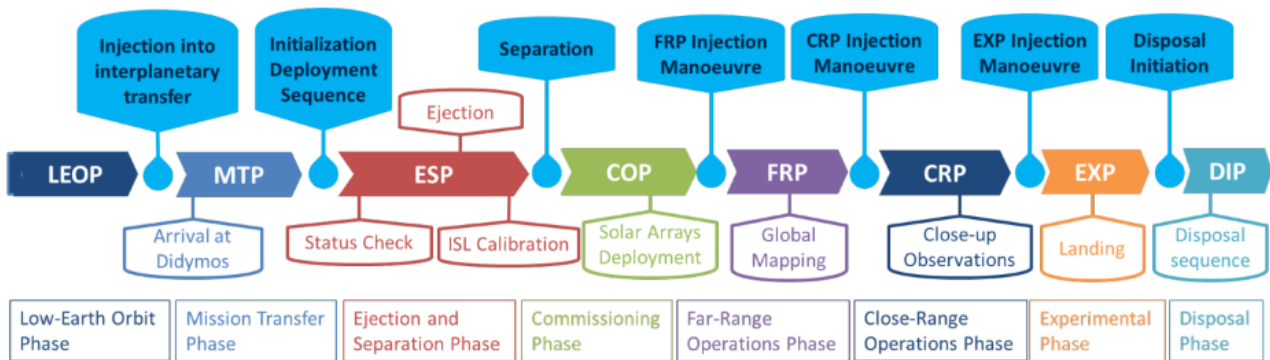

Figure 1. Milani mission phases

- **Low Earth Orbit Commissioning Phase (LEOP)**, ~2-3 months, will be done on Hera spacecraft upon launch; a specific list of checkout tests will be executed also on Milani CubeSat to verify the basic functionalities that can be verified in stowed and integrated configurations
- **Mission Transfer Phase (MTP)**, or interplanetary cruise, ~2 years, will be characterized by regular checkout tests to be executed on Milani CubeSat to verify the basic functionalities
- **Ejection and separation phase (ESP)**, ~2-3 weeks (TBC), will start upon arrival to the asteroids and will be characterized by checkout test in stowed configuration, ejection of Milani CubeSat outside Hera, pre-deployment checkout in exposed configuration (Milani still attached to Hera, but exposed to the space environment), Milani CubeSat separation from Hera
- **Commissioning Phase (COP)**, ~1-2 weeks (TBC), checkout, stabilization, and calibrations
- **Far Range Operations Phase (FRP)**, ~3-4 weeks (TBC), transfer to the operative orbits, first global mapping, and technologies demonstration
- **Close Range Operations Phase (CRP)**, ~3-4 weeks (TBC), transfer to the operative orbits closer to the asteroids, Close-up observation of Didymos bodies, additional technology demonstration, observation of the DART impact crater
- **Experimental Phase (EXP)**, foreseeing the landing on the asteroids or transfer on a heliocentric graveyard orbit, currently under evaluation
- **Disposal Phase (DIP)**, ~2 weeks (TBC), Passivation

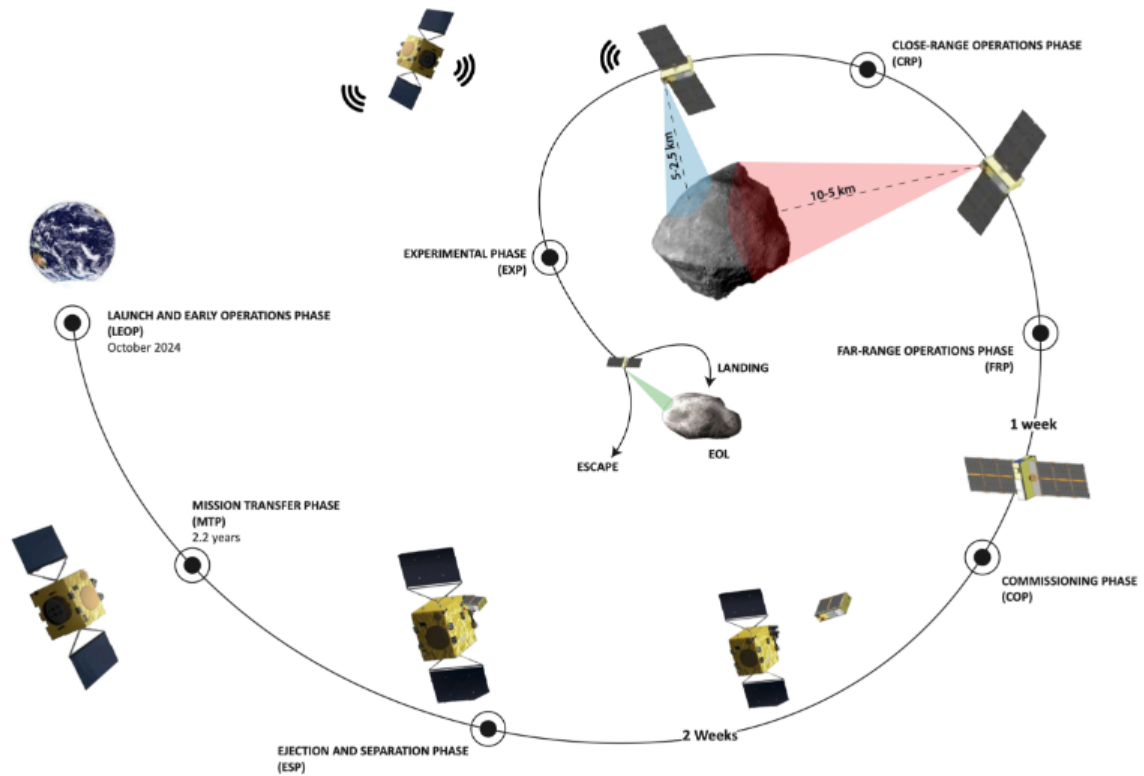

Figure 2. Hera Milani reference mission

Main phases of Milani's mission related to the achievement of the scientific mission objectives, are the Far Range Phase (FRP) and Close Range Phase (CRP).

3.1 Far Range Phase (FRP)

The complete mapping of the bodies with a resolution better than 2 m/pixel with ASPECT can be achieved with observations at a distance lower than 11 km from the surface. This is accomplished during the Far Range Phase in which Milani hovers over the bodies in a repetition of loop orbits quasi-symmetric with respect to the Sun direction. Figure 3 shows the trajectory as a 6-points hyperbolic loop with a manoeuvring pattern of 4-3 days repeated three times:

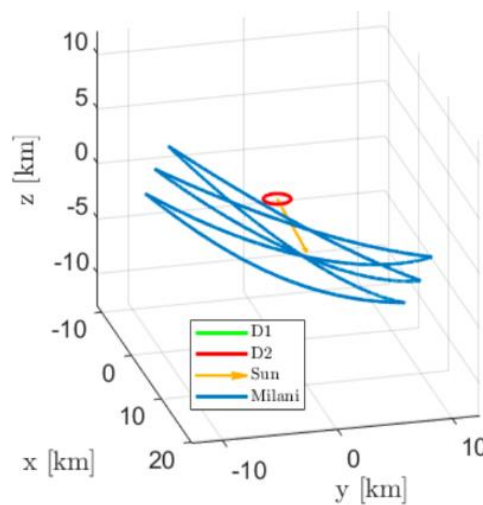

Figure 3. FRP trajectory in DidymosEquatorialSunSouth (source: Politecnico di Milano)

3.2 Close Range Phase (CRP)

The complete mapping of the bodies with a resolution better than 1 m/pixel and the DART crater observations are achieved during Close Range Phase. The latter being the most challenging goal of the phase, with a maximum distance requirement of 2.78 km from D2, the CRP design has been focused on the crater observation. Instead, the complete mapping is a by-product of this phase. Due to the tidally locked nature of the system, the observation of a feature fully illuminated and visible is possible only in specific configurations of the two bodies. In this case, since the DART crater will be on the leading side of D2, the crater can be visible and illuminated only around the D2 dawn at each revolution of D2 around D1. Fulfilling both the resolution and phase angle constraints, when D2 is in that configuration, while respecting the operational constraints on the manoeuvring frequency and the permanence into the dayside, makes it impossible to adopt the same trajectory design strategy as in the FRP. Consequently, a slightly modified waypoints strategy has been used for the CRP design. Indeed, CRP design is based on the selection of KeyPoints. A KeyPoint is the position at which the satellite can perform the desired scientific observation fulfilling all the requirements. Thus, while the relative position of the KeyPoints ensures the fulfilling of the scientific requirements, the manoeuvring points position serves to comply with the constraints and to ensure the flyability of the trajectory. Indeed, CRP design has been performed in an iterative fashion considering the navigation assessments results to make it robust to uncertainty and increase its flyability. In fact, many CRP arcs last 7 days, to allow for a correction manoeuvre execution in the middle of a nominal ballistic arc. Furthermore, at the end of CRP, Milani will be injected into a Sun Synchronous Terminator Orbit (SSTO) and to facilitate this plane change, during CRP, Milani slightly increases its declination with respect to the equatorial plane.

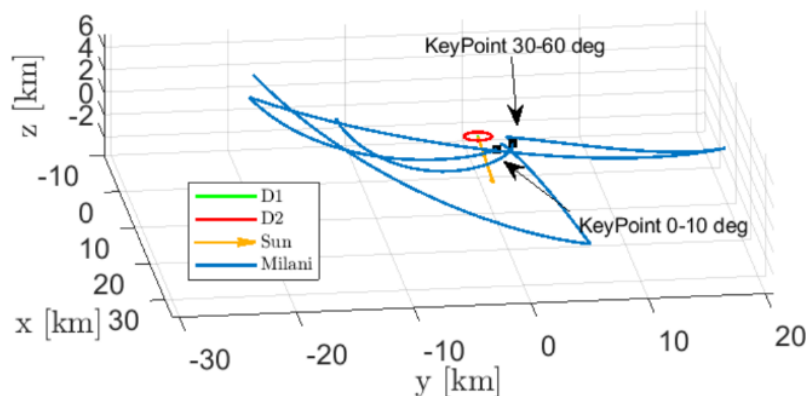

Figure 4. CRP trajectory in DidymosEquatorialSunSouth (Source: Politecnico di Milano)

The complexity of orbiting in a highly perturbed low-gravity environment is increased using miniaturized components and considering the relative operational constraints. The solutions elaborated and presented by PoliMI team show how the design gets more complex when the CubeSat needs to get closer to the system. During the Close Range Phase the spacecraft must get very close to Dimorphos; Thus, it requires a complex asymmetric design with the definition of KeyPoints at which Milani can perform science and a concurrent phasing with the motion of Dimorphos and the manoeuvring schedule of Hera. Milani navigation and guidance also get more complex during CRP.

4 System Overview

Milani CubeSat leverages on Tyvak avionics modules, and the overall vehicle design was customized for the Milani mission. The satellite was entirely realized in Tyvak International premises in Torino. In Figure 5 a picture of the Milani PFM is shown:

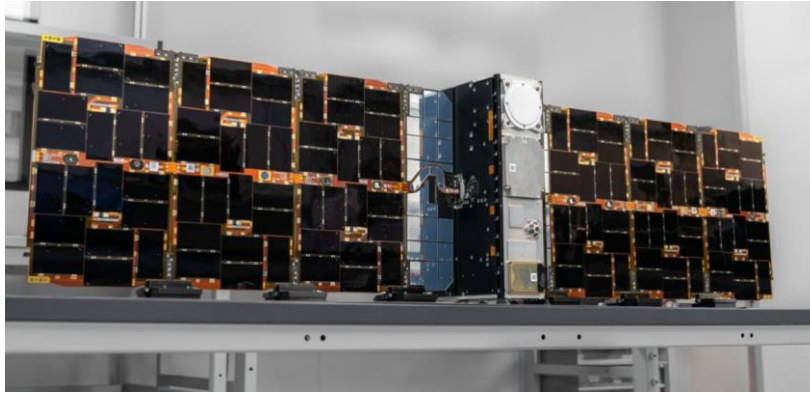

Figure 5. Milani ProtoFlight Model

The CubeSat system is composed of the following elements:

- Avionics (Tyvak Mark II technology), including Flight Computer, Electrical Power System, ADCS
- Primary Payload (ASPECT)
- Secondary Payload (VISTA)
- Laser retroreflectors
- Cold-gas propulsion system, enabling technology
- External Inter-satellite link (ISL) radio + antennas
- Navigation Camera
- COTS components
- Mission Specific Interfaces (such as Payload Interface Board, PIB, Backplane, Flight Umbilical)

The satellite main features are summarized in the table below:

	Value (~)
Mass	12kg
Power generation @ 1AU	80W
Data budget	9.2Gb
Delta V budget	4.2m/s

Table 1. Milani Satellite main features

Details related to some of the main systems are presented in the following sections.

4.1 Avionics

Milani is a 6U-XL CubeSat which configuration was designed expressly for the Milani mission. It uses the Tyvak avionics modules, designed to support satellite applications ranging from 6U nanosatellites up to 350 kg microsatellites. The processing platform is a system designed by Tyvak with a radiation hardened watchdog microcontroller. The processing modules contain on-board storage for housekeeping telemetry collection. Standard communication systems (UHF, S, and X band radios options) available for telemetry and command of the satellite, for the Milani mission are replaced with the Inter Satellite Link system. The ADCS software runs on a Xilinx Zynq 7030 platform and can interface with multiple star trackers for guaranteed stellar coverage and a Inertial Measurement Unit (IMU). As a contingency, redundant coarse sensors and magnetometers allow sun pointing independent of the IMU and star trackers. For actuation, the system uses the nano-reaction wheels. Milani Electric Power System is composed by two battery modules, one MPPT module, one Load Controller Module and two trifold solar array wings.

Specification	Capability
Bus Provided Redundant Data Storage	6GB
Data Buses	RS-422, Ethernet
Power Rails	9-12.6V Unregulated, 5V, 3V3
Thermistors	13
Survival Heaters	8
Single Axis Solar Array	3 panels per wing
Solar Array Peak Power	Up to 133W

Table 2. Milani Satellite features

4.2 Propulsion System

The “IANUS” propulsion system was developed ad hoc for the Milani mission by T4I (Technology for Propulsion and Innovation, Italy) responsible for the tank and fluidics design, analyses, manufacturing and system qualification, and Tyvak International, responsible for the mechanical interfaces and accommodation definition, specific control electronics and control SW.

Ianus is composed by two identical 0.5U modules, each one is a 6 degrees-of-freedom cold-gas system propelled with R134-a. R134-a is a non-flammable fluid characterized by chemical and thermal stability, low toxicity, high security and an ozone depletion potential equal to 0.

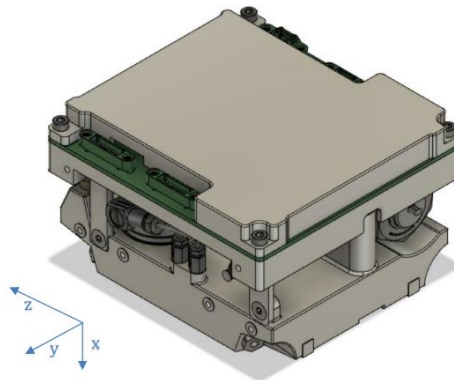

Figure 6. Ianus propulsion system rendering and reference frame

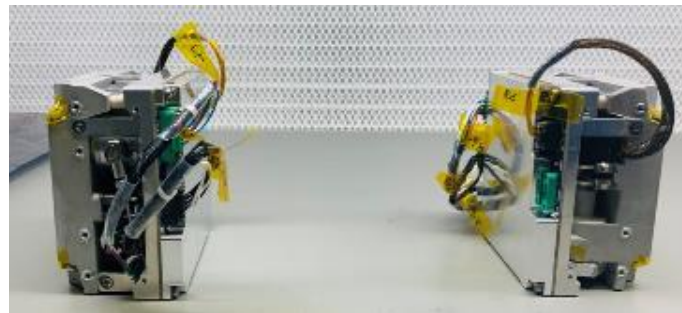

Figure 7. Ianus propulsion system Flight Units

Main IANUS features are summarized in the Table 3 below:

Specification	Capability
Number of modules	2 (identical)
Envelope (each module)	100x95x60mm
Mass (per module)	600g
Total Impulse (per module)	38 Ns

Specification	Capability
Power (per module)	2W stand-by, <30W peak power, 20W firing
Max continuous impulse	6.0 Ns in <300s
Mission lifetime	3 years
Specific Impulse	>40s
Leakage	< 1e-6 SCCS of Helium total
Time-to-fire	<5mins
Thrust level	9.2mN(x), 10.8mN(y), 26.4mN(z)
Degrees-of-freedom	6
Electronics	Included (each module is independent)
Operative Temperature range	[-10; + 50] degC
Non-operational temperature range	[-30, + 60] degC

Table 3. Ianus propulsion system main features

The system is composed of three main subsystems: 1) structural subsystem, 2) fluidic subsystem, and 3) electronics subsystem. The **structural subsystem** is composed of i) tank, ii) lid, iii) electronic lid, and iv) valve clamps. The tank has both structural and fluidic functions as it contains the pressurized propellant and provides the mechanical interface towards the satellite. Nonetheless, it embeds fluidic channels, manifolds, and fluidic interfaces. The tank also houses the inclined surfaces on which the 4 nozzles are installed. The tank's hybrid nature, together with the total absence of welded parts, is enabled by the fact that it is 3D-printed with high grade Aluminum alloy. The tank lid gives mechanical support to various fluidic elements and to the electronic subsystem. The electronic lid is mainly a protective cap against cosmic radiations for the electronic board and it's mounted on the tank lid. The valves' clamps, finally, are used to provide both rigidity and damping properties to these fluidic components.

The **fluidic subsystem** is composed of the tank, the evaporator, a passive pressure regulator, four nozzles, tubes and channels, one main isolation valve and four normally closed solenoid valves (1 for each independent nozzle branch).

The **electronics subsystem** is composed by the electronic board (PCU, Propulsion Control Unit) and the electric wires and its main purpose is to communicate with the satellite (e.g., receive commands, send telemetry), to control the system actuators such as valves and heaters, and to read pressure and temperature levels. Each Ianus modules can operate independently.

4.3 Navigation Camera

The Navigation Camera is based on a Tyvak Star Tracker technology, customized for the Milani mission. Optical lenses were designed and coated specifically for Milani by Optec SpA. Image Processing algorithms were developed by Politecnico di Milano. **Tyvak ProxOps Vis Imgr WFOV Enhanced** camera was selected as baseline for the mission, due to FOV constraints for the primary navigation camera, namely the requirement to keep the whole system in view at all mission ranges. A Jenoptik DLEM-30 LIDAR is also present on the satellite, and considering the relatively small range, it is complementary to the primary NavCam. In fact, it will mainly ease the relative navigation with respect to the target in the Close Range Phase (CRP) and in the Experimental Phase (EXP), where the main navcam would be saturated by Didymos. Main NavCam feature are summarized in the following table:

Feature	Capability
Sensor	Tyvak ProxOps Vis Imgs WFOV RGB
Resolution	116mm @500m distance 464mm @2km distance 2.32 @10km distance

Feature	Capability
Angular FOV	21x16deg
Horizontal FOV	185m @500m distance 740m @2km distance 3.7km @10km distance
Sensor size	2048x1536 px
Pixel size	2.20 um
Focal length	13mm

Table 4. NavCam main features



Figure 8. Milani Navigation camera (no baffle, left; with baffle, right)

4.4 Main Payload (ASPECT)

ASPECT payload is a hyperspectral imager operating in the visible and infrared part of the electromagnetic spectrum.



Figure 9. Milani main Payload: ASPECT hyperspectral imager

The scientific goals of ASPECT are hereafter reported:

- ASP SG1 - To map the global composition of the Didymos asteroids
- ASP SG2 - To characterize the surface of the Didymos asteroids
- ASP SG3 - To evaluate space weathering and global shock effects on Didymos asteroids
- ASP SG4 - To identify local shock effects on Dimorphos caused by DART impact

To fulfil the scientific objectives, ASPECT imager covers the wavelength range of 500 – 2500 nm, and has imaging capability between 500 and 1650 nm. Indeed, the imager is split into four channels:

- VIS (500-900 nm)
- NIR1 (850 - 1250 nm)
- NIR2 (1200 - 1650 nm)
- SWIR (1600 - 2500 nm)

The VIS and NIR channels have imaging capability, while the SWIR channel is non imaging (single pixel). All channels are independent (i.e. redundant) and can be powered on and operated separately

if needed. By covering this wavelength range, ASPECT can identify the silicate minerals that make up S-type asteroids. Covering this wavelength range is important, as it allows the study of space weathering effects on the asteroid surfaces. ASPECT can also provide information about shock effects on asteroid surfaces, as it can image the DART impact crater.

Main instrument parameters, characteristics and performances are hereafter presented:

Parameter	VIS channel	NIR1 channel	NIR2 channel	SWIR channel
Field of View [deg]	10 x 10	6.7 x 5.4	6.7 x 5.4	ca 5.85 circular
Spectral range [nm]	500 - 900	850 - 1250	1200 - 1600	1650 - 2500
Image size [px]	1024 x 1024	640 x 512	640 x 512	1 x 1
Pixel size	5.5 x 5.5 μ m	15 x 15 μ m	15 x 15 μ m	1 x 1 mm
No. spectral bands	Ca. 14	Ca. 14	Ca. 14	Ca. 30
Spectral resolution [nm]	< 20	< 40	< 40	< 40

Table 5. ASPECT main parameters

Parameter	Value
Total Mass	1,5 kg
Power consumption during acquisition	13-14W
Total amount data	4.7 Gbit

Table 6. ASPECT main characteristics

Parameter	VIS channel	NIR 1/2 channel	SWIR channel
Image size (km x km) @10km	1750m x 1750m	1170m x 940m	1022m (spot diameter)
Ground resolution @10km	1.7m	1.8m	1022m (spot diameter)
Image size (km x km) @5km	875m x 875m	585m x 469m	511m (spot diameter)
Ground resolution @5km	0.85m	0.9m	511m (spot diameter)
Image size (km x km) @1km	175m x 175m	117m x 94m	102m (spot diameter)
Ground resolution @1km	0.17m	0.18m	102m (spot diameter)
Spectral resolution	Ca 30 nm	Ca 30 nm	Ca 45nm
Spectral range	500-900 nm	851650 nm0	1600-2500 nm
Mean SNR @1 AU	Ca 60-70	Ca 60-70	>60 (TBC in mission)
Mean SNR @1.75 AU	Ca 50-60	Ca 50-60	>60 (TBC in mission)
Mean SNR @2.5 AU	Ca 40-60	Ca 40-60	Ca. 60

Table 7. ASPECT performances

The interface with the Milani vehicle is ensured through a mission specific Payload Interface Board. The ASPECT Payload development is led by VTT, leveraging on the support of other entities covering specific areas: Brno University of Technology, responsible for the design of the ASPECT Payload data processing algorithms and workflow design, Institute of Geology of the Czech Academy of Sciences (GLI), responsible for the Didymos asteroid 3D shape reconstruction and hyperspectral data processing, University of Helsinki developing novel algorithms to determine asteroid composition through hyperspectral data, Kuva Space, managing the development of the ASPECT Payload DPU, HULD, managing the ASPECT Payload Controller.

4.5 Secondary Payload (VISTA)

In the framework of Hera Mission for MILANI CubeSat scenario, Volatile In-Situ Thermogravimetry Analyser (VISTA) Payload, in synergy with ASPECT scientific objectives, will accomplish the following scientific goals:

- VIS SG1 – Detect the presence of dust particles smaller than 10 μ m (residual dust particles from the impact and suspended dust in the binary system or coming from dust levitation process);
- VIS SG2 – Characterization of volatiles (e.g., water) and light organics (e.g., low carbon chain compounds) by using TGA cycles, i.e. heating controlled thermal cycles. The desorption rates

at specific temperatures are used to characterize volatiles and organics desorbed by the sensor surface;

- VIS SG3 – Molecular contamination monitoring in support to other CubeSat instruments and ASPECT Spectrometer, coming from outgassing processes on-board the spacecraft/CubeSat hardware components.



Figure 10. Milani secondary Payload: VISTA

VISTA sensor head is the instrument core and is composed of three separate sub-units packaged in a shielded enclosure which includes:

- The first sub-unit includes two quartz crystals mounted in a sandwich-like configuration. The top one is the sensing crystal, which is exposed to the external environment and collects the outgassing material. The bottom one is the reference crystal. The output signal is the beating frequency i.e., the frequency difference between sensing and reference crystal. Since the two crystals work in thermal equilibrium, their difference is in principle not affected by temperature effects
- The second sub-unit is the Thermal Control System (TCS), which drives and regulates the temperature of the crystals. It is composed by the built-in resistors on the crystals (i.e., the two heaters and the two temperature sensors) and one Thermoelectric Cooler. The TCS temperatures will be controlled by FCM and managed by OBS. In particular, the TCS is useful to guide the crystals at temperature +30K (heaters) or more and -5K (TEC) or less with respect to the temperature of the external environment in the range from 253K to 313K (temperature range of MILANI).
- The third sub-unit is the Proximity Electronics (PE), including an Oscillator and a Beating module.

Main instrument characteristics are hereafter presented:

Parameter	Value
Mass budget	0,9 kg
Power consumption during heating/calibration	< 1,5W
Total Data volume	1,6 Mbit

Table 8. VISTA main characteristics

The interface with the Milani vehicle is ensured through a mission specific Payload Interface Board. The VISTA Payload development is led by INAF-IAPS (Istituto Nazionale di AstroFisica – Istituto di Astrofisica e Planetologia Spaziali), leveraging on the support of other entities covering specific areas: Institute on Atmospheric Pollution Research of the CNR (CNR-IIA), responsible for the piezoelectric crystals and Proximity Electronics development, integration and testing, Politecnico di Milano (PoliMI), responsible for the thermo-mechanical design, payload integration and testing.

4.6 Interfaces

Interfaces with the Hera mothercraft are:

- **Deep Space Deployer.** The CubeSat System is integrated into the Deep Space Deployer (DSD) developed by ISIS, providing also a specific CubeSat Interface Board to interface the Milani CubeSat with the DSD
- **Life Support Interface Board.** The main interface with the assembly constituted by the DSD and Milani CubeSat with the Hera mothercraft is the Life Support Interface Board (LSIB), developed by KUVA Space and allowing the exchange of power and data between the two spacecraft and so the execution of the checkout tests during the stowed and exposed configuration.

Deep Space Deployer (DSD), provided by ISIS
Milani-to-Hera interface during launch and cruise phase

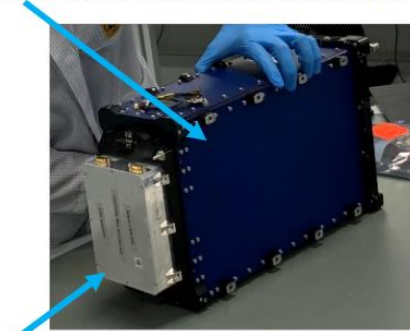

Life Support Interface Board (LSIB)
Deployer-to-Hera interface



Figure 11 (left). Deep Space Deployer and Life Support Interface Board
Figure 12 (right). Milani CubeSat Interface Board (interfacing the CubeSat with the DSD pusher plate)

Interfaces were validated during the program execution through the implementation of an incremental validation approach. Multiple Milani models were developed aiming at testing and verifying specific interfaces.

The first model developed was the **reduced Engineering Model (rEM)**, composed by a basic set of avionics and ISL radio and aiming at testing SW and Electrical interfaces with Hera Avionic Test Bench located at OHB, Bremen. The rEM was delivered in the frame of the Milani CDR, and was used to verify the interface by UART and ISL RF with HERA Avionics Test Bench (ATB). Specifically, the rEM can interface with the LSIB - used to communicate through an umbilical connection with HERA - and the ISL, to exchange Telecommands (TC) and Telemetry (TM) with the mothercraft on both channels.



Figure 13. Milani reduced Engineering Model (rEM)

The **Structural and Thermal Interface Model (“STIM”)** was developed to support the Hera environmental test campaign (vibration, thermal-vacuum, acoustic) and as such, it is fully representative from a mechanical and thermal perspective. In addition to this, in order to execute the health checks and charging, simulating the cruise stowed configuration and periodical checks, the

STIM was equipped with a sub-set of required avionics and dummy masses. The STIM executed a stand-alone qualification at CIRA facility in Italy, including vibration tests, shock, thermal vacuum, mass properties measurements, before the delivery to ESA to support the Hera environmental campaign. At the moment of the submission of the present paper, the STIM successfully the Hera testing (nominal status was verified during the tests execution and upon completion of these).



Figure 14. Milani Structural and Thermal Interface Model (STIM)

The Milani **Engineering Model (EM)** was developed mainly to validate internal interfaces from a mechanical perspective (mechanical fit-check prior to flight parts procurement, including harness routing) and electrical perspective (functional tests of all the subsystems). The EM was also used to execute the first fit check with the Deep Space Deployer and an EMI / EMC campaign to verify compliance to Hera requirements (H and E field radiated emission test, H and E field susceptibility test, DC Magnetic momentum measurement). This campaign was successfully executed in December 2022 confirming Milani compliance with all the requirements. Since then, the Engineering Model is used by Tyvak as test bench for SW debug and general testing activities, including interfaces with the Milani Mission Control Center.



Figure 15. Milani Engineering Model and DSD fit check

4.7 Radiation assessment

A radiation-related effort aimed at mitigating risks associated to the execution of the mission in deep space environment. The radiation analysis effort is led by Politecnico di Torino team (Dipartimento di Automatica e Informatica - DAUIN) and includes both fault injection approaches and dedicated radiation testing (Heavy Ion, for component level testing, and High Energy proton, for Single Event Effects sensitivity evaluation).

Heavy ion test campaign was executed at UCL, Lauvain-la-Neuve, Belgium, on a subset of components identified as critical for the mission environment. Main objective was to verify no SEL nor other destructive events on at least 2 samples ((LET=46.1 MeV·cm²/mg , Fluence_{MIN}=1E7 particles) for each batch of components to be tested. As main outcome, none of the tested parts showed overcurrent conditions nor destructive events in the pre-defined stress conditions, each of the tested parts consistently survived the test conditions until the pre-defined minimum fluence threshold.

High Energy Proton test campaign was executed at PIF PSI in Villigen, Switzerland, on a subset of dedicated subsystems (EPS and OBC), mounted together forming a minimal but functional flatsat. This is not a typical configuration for HEP testing but, considering the advanced stage of the project and resource availability, the one arranged for this test was the best compromise between the constraints and the need of insight on the system reaction to SEL and electrical failures induced by HEP. Main objective was to verify no SEL nor destructive events up to the fluence of 1e11 p/cm², with proton energy of at least 200MeV, on each of the modules irradiated. As main outcome, no destructive events arose, even though the target fluence has not been reached on two of the modules.

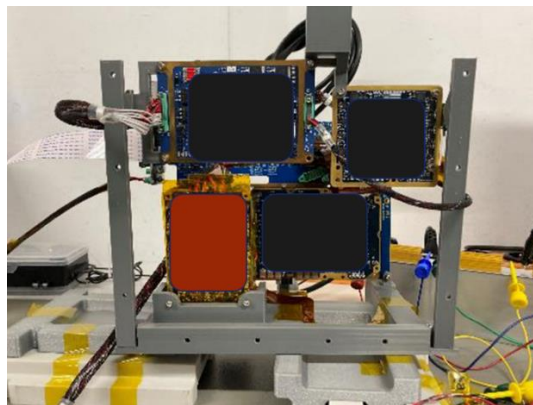

Figure 16. Modules PCBA setup exposed to High Energy Proton beam

Both radiation test campaigns gave precious information about the behaviour of single components (ICs) but also about the behaviour of a system, like a Flatsat, in case of errors and anomalies happening on a specific module. The analysis of these effects allowed to implement specific strategies and features, such as FDIR, aimed at making the whole system more robust to the radiation effects.

5 Conclusions

Milani CubeSat was developed in 3 years, including qualification at Centro Italiano Ricerche Aerospaziali (CIRA, Italy). In this challenging timeframe, multiple technologies were developed (including propulsion system, navigation camera, Intesatellite Link, mission specific interfaces, etc.), as well as three payloads (ASPECT, VISTA, retroreflectors) and four vehicle models (including the PFM). In addition to that, multiple test and validation campaigns (including also tests with Hera

mothercraft) were executed. On March 14th 2024 the satellite was officially delivered to ESA to prepare for the next phases of integration, launch and operations.

6 Acknowledgement

The authors would like to acknowledge the support received by the whole Milani Consortium and European Space Agency team following and supporting the Milani mission development.