

PAPER • OPEN ACCESS

Scaling the mid-IR radiation at 7 μm - two-stage double-pass 195 MHz narrow-bandwidth DFG laser system

To cite this article: L I Stoychev *et al* 2023 *J. Phys.: Conf. Ser.* **2487** 012032

View the [article online](#) for updates and enhancements.

You may also like

- [The Design and Simulation of a Fifth-order Chebyshev Low-Pass Filter](#)
Aodong Mei
- [An Accurate Co-registration Method for Airborne Repeat-pass InSAR](#)
X T Dong, Y H Zhao, X J Yue *et al.*
- [Microstructure and Mechanical Properties of Ultra-High Strength Pearlitic Wire in Single-pass Cold Drawing](#)
M Z Wei, Z H Chen, X M Zhang *et al.*



Connect with decision-makers at ECS

Accelerate sales with ECS exhibits, sponsorships, and advertising!

▶ Learn more and engage at the 244th ECS Meeting!

Scaling the mid-IR radiation at 7 μm - two-stage double-pass 195 MHz narrow-bandwidth DFG laser system

L I Stoychev¹, M Baruzzo^{2,3}, J J Suárez-Vargas^{2,3}, H Cabrera^{2,4}, I P Nikolov⁵, A A Demidovich⁵, M B Danailov⁵ and A Vacchi^{2,3}

¹Institute of Solid State Physics, Bulgarian Academy of Sciences, Sofia 1784, Bulgaria

²Sezione di Trieste, Istituto Nazionale di Fisica Nucleare, Trieste 34149, Italy

³Mathematics and Informatics Department, Udine University, Udine 33100, Italy

⁴Optics Lab, The Abdus Salam International Centre for Theoretical Physics, Trieste 34151, Italy

⁵Elettra-Sincrotrone, S.C.P.A, Trieste 34149, Italy

Corresponding author: stoychev@issp.bas.bg, lyubomir.stoychev@gmail.com

Abstract. We present a laser system based on difference frequency generation (DFG) to produce tunable, narrow-linewidth (<30 pm), and high-energy mid-IR radiation in the 6785 nm region. The system exploits nonlinear crystals (such as LiInS₂, LiInSe₂ and BaGa₄Se₇) and nanosecond pulses generated by single-frequency Nd:YAG and Cr:forsterite lasers at 1064 and 1262 nm, respectively. Various experimental configurations are used: single-pass and double-pass through the nonlinear crystal. Additional increments of the output energy can be obtained by performing two stage double-pass geometry.

1. Introduction

Lasers with narrow linewidth and high stability in the emitted wavelength are required for high-precision spectroscopic measurements. Some applications require pulsed lasers with high pulse energy (in the mJ range) and short nanosecond pulse duration. The motivation behind our work is the foreseen high-precision laser spectroscopy measurement of the hyperfine splitting in the ground state of muonic hydrogen, with a relative accuracy better than 10^{-5} , that requires tunable, narrow-linewidth $\Delta\lambda < 70$ pm (450 MHz), high-energy laser source (>1.5 mJ) emitting at 6785 nm at 25 Hz pulse repetition [1]. Nowadays there are a numerous mid-infrared sources emitting in the mid-IR region like solid state lasers, gas lasers, laser systems using frequency conversion and quantum cascade lasers (QCL). Nevertheless none of these fulfils all the requirements needed. QCL are tunable and narrow-bandwidth sources but they lack scaling of energies. On the other side the frequency conversion based sources using parametric processes are easily scaled in terms of energy but the emitted radiation is very broad and usually spreads over tenths of nanometers. A solution can be found in the progress of sources based on nonlinear frequency down conversion pumped by solid-state lasers. This approach allows high-energy pulses exceeding 1 mJ to be generated in a wide range of mid-IR wavelengths. Amongst all optical parametric down conversion processes the DFG favours from its intrinsic property of generating pulses with narrow linewidths.



2. Experimental setup and results

We developed a DFG-based system (schematic diagram given in figure 1) emitting pulsed mid-IR radiation with extremely narrow bandwidth ($\Delta\lambda/\lambda \leq 5 \times 10^{-6}$) smoothly tunable in the spectral range 6730–6840 nm with a step of 34 pm, linewidth < 30 pm (195 MHz) and output energy up to 540 μ J in a double-pass geometry [2]. This energy is generated by mixing nanosecond pulses of a single longitudinal mode (SLM) Nd:YAG laser at 1064 nm and a SLM Cr:forsterite laser system tunable around 1262 nm in non-oxide nonlinear crystals - a commercially available LiInS₂ crystal with dimensions of 7x7x20 mm, cut in the XY plane ($\theta=90$ deg, $\phi=35.4$ deg). The pulses of both laser beams are synchronized by a delay generator. The tuning of the DFG emission at fixed pump wavelength is obtained by tuning the signal wavelength and rotating the NL crystal to the corresponding phase-matching angle. A system consisting of energy sensors and cameras was integrated in order to monitor in real time the pulse energies of the lasers and track their beam positions. The last giving the possibility to register (and when needed to adjust through the power supply) the energies of both laser beams and also to direct them with the use of mirrors mounted on piezo tip/tilts to the nonlinear crystals for best phase matching. The design of this system allows a straightforward extension in tunability and pulse energy.

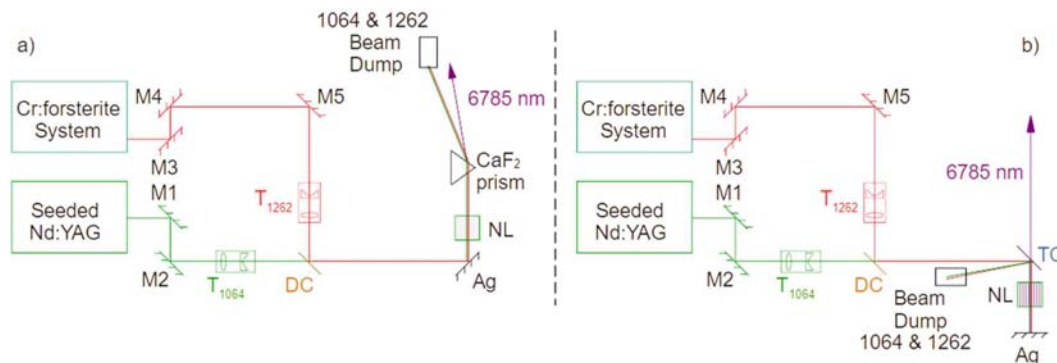

Figure 1. Schematic diagrams of the DFG experimental setups: a) single pass, b) double pass. M1, M2 – mirrors (HR at 1064 nm), M3-M5 – mirrors (HR at 1262 nm), T₁₀₆₄ – telescope AR at 1064 nm, T₁₂₆₂ – telescope AR at 1262 nm, DC – dichroic mirror (S1: Tp>99.3% at 1064nm and Rs>97% at 1262 nm; S2: AR at 1064 nm, AOI=45°), TC – trichroic mirror (S1: Rp>97% at 1064 nm, Rs>99% at 1262 nm, Rp<10% at 6785 nm; S2: AR at 6785 nm), NL – nonlinear crystal, Ag – silver mirror.

In the quest of higher energies we propose a new two-stage geometry of the DFG system based on the well-known fact that the DFG can be considered as a process of amplification of the signal pulses, in the nomenclature – pump (1064 nm), signal (1262 nm) and idler (6785 nm). The emission of each photon at 6785 nm goes simultaneously with the emission of a photon at 1262 nm. With energy ratio $E_{\text{PHOTON@1262}} \approx 5,376 \times E_{\text{PHOTON@6785}}$, the generation of each 1 mJ of radiation at 6785 nm, will add to the energy available at 1262 nm $\sim 5,376$ mJ. Thus making it feasible to use this amplified light at 1262 nm in a second DFG process with another nonlinear crystal put in parallel (see figure 2).

For the purpose the light at 1064 nm is split in two beams – the first taking place in the first DFG process and the second one is mixed with the amplified radiation at 1262 nm in a second DFG process. To compensate the delay (accumulated during the first DFG process) of the amplified light at 1262 nm an additional optical delay is introduced in the optical path of the second beam at 1064 nm so they arrive synchronously at the second nonlinear crystal. The polarizations of both beams (1064 nm & 1262 nm) in the second DFG process are rotated at 90° with respect to the polarizations of the initial beams. Thus the polarization of the second beam at 6785 nm is rotated at 90° to the first one. This allows the two beams at 6785 nm to be combined collinearly through a beam-combining polarizer, thus propagating as one single beam.

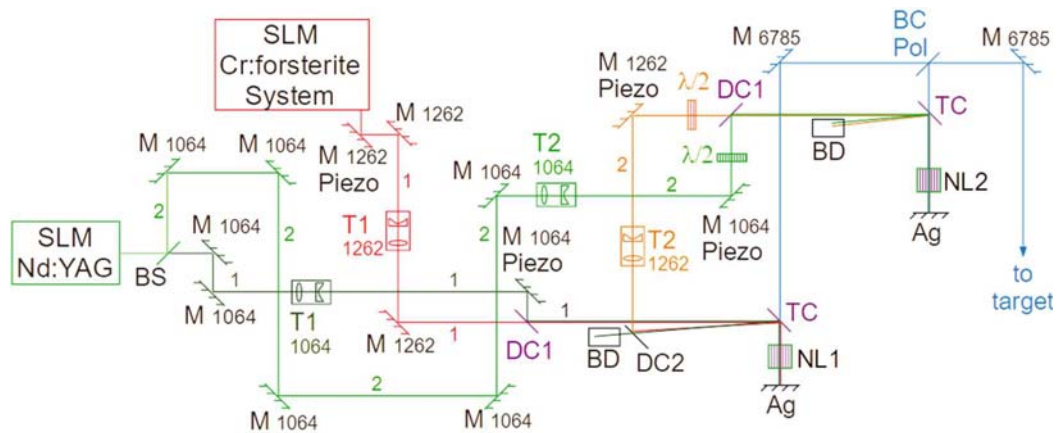

Figure 2. Schematic setup of the two-stage double-pass DFG: BS – beam splitter at 1064 nm, M_{1064} – HR mirror at 1064 nm, M_{1264} – HR mirror at 1262 nm, M_{6785} – HR mirror at 6785 nm, Ag – silver mirror, T_{1064} & T_{2064} – telescopes at 1064 nm, T_{1262} & T_{2262} – telescopes at 1262 nm, DC1 – dichroic mirror (HR at 1064 nm & HT at 1262 nm), DC2 – dichroic mirror (HT at 1064 nm & HR at 1262 nm), TC – trichroic mirror (HR at 1064 & 1262 nm & HT at 6785 nm), $\lambda/2$ – half-wave plate, BC_{Pol} – beam combining polarizer at 6785 nm, M_{xxxx} Piezo – HR mirror at XXXX nm mounted on piezo tip/tilt.

Analyzing the results of the output energies for the two geometrical setups - single pass and double pass - generated using two commercially available crystals, both cut in the XY plane ($\theta=90$ deg, $\phi=35.4$ deg), with different dimensions (5x5x15 mm and 7x7x20 mm) we observed a difference in the energy scaling related with the transverse dimensions of the nonlinear crystals (figure 3). It is easy to notice that for the LiInS_2 crystal with smaller transverse dimensions (5x5x15 mm) the increment of the output energy in double pass configuration is three times higher compared with that of the single pass geometry – 250 μJ and 82 μJ , respectively. While in the case of the 7x7x20 mm LiInS_2 crystal the increment is only two times – 415 μJ and 205 μJ , respectively, at identical energies of both pump and signal beams.

A possible explanation of the difference in the energy scaling for the crystals with different transverse dimensions we find in the fact that in the geometry used for the double pass configuration the silver back-reflecting mirror (Ag in figure 1b and figure 2) is tilted at a small angle in order to avoid the propagation of the reflected light of the pump and signal beams back to the laser. This tilt of the back mirror decreases the phase matching conditions in the second pass of the DFG process, thus decreasing the overall efficiency of the process. The tilt angle is smaller in the case of the nonlinear crystal with smaller transverse dimensions, thus the phase matching conditions are better fulfilled in this case, which explains the higher efficiency of the process, respectively the higher scaling of the output energy, compared with the results for the crystals with bigger transverse dimensions.

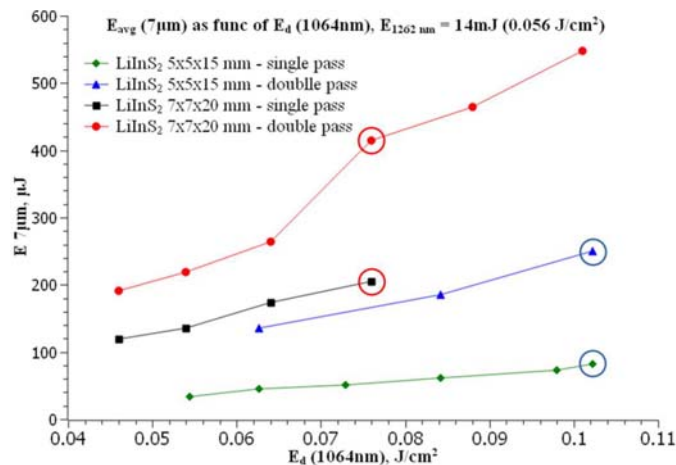

Figure 3. Output energies of the DFG system in two different geometries – single pass and double pass – for two nonlinear crystals LiInS₂ – 5x5x15 mm and 7x7x20 mm.

This observation has led us to propose a modified geometrical configuration of the two-stage double-pass setup aimed to improve the phase matching conditions of the DFG process (see figure 4). In this scheme in the optical path on each of the pump and signal beams a polarizer and a rotator at 45° are introduced. In such optical configuration the polarization of the reflected light from the back mirror (Ag) after the second pass through the rotator is rotated at 90° and therefore reflected by the polarizer, so avoiding the back propagation into the lasers. Such optical geometry allows us to set the back-reflecting mirror at normal incidence angle with respect to the pump and signal beams propagation which favours to obtain best phase matching conditions for both DFG processes.

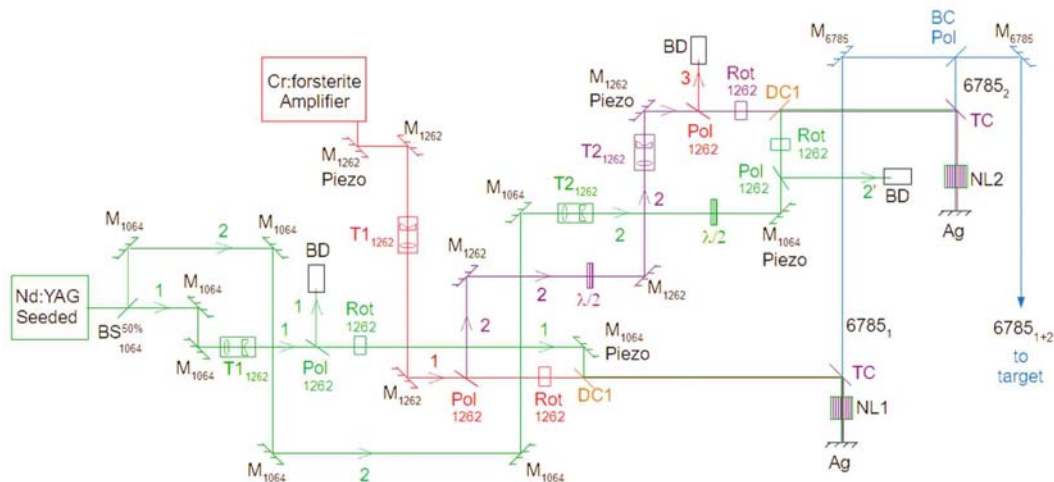

Figure 4. Schematic setup of the modified two-stage double-pass DFG: BS – beam splitter at 1064 nm, M₁₀₆₄ – HR mirror at 1064 nm, M₁₂₆₂ – HR mirror at 1262 nm, M₆₇₈₅ – HR mirror at 6785 nm, Ag – silver mirror, T₁₀₆₄ & T₂₀₆₄ – telescopes at 1064 nm, T₁₂₆₂ & T₂₁₂₆₂ – telescopes at 1262 nm, DC1 – dichroic mirror (HR at 1064 nm & HT at 1262 nm), TC – trichroic mirror (HR at 1064 & 1262 nm & HT at 6785 nm), λ/2 – half-wave plate, Pol₁₀₆₄ – polarizer for 1064 nm, Pol₁₂₆₂ – polarizer for 1262 nm, Rot₁₀₆₄ – 45° rotator at 1064 nm, Rot₁₂₆₂ – 45° rotator at 1262 nm, BC_{Pol} – beam combining polarizer at 6785 nm, M_{XXXX} Piezo – HR mirror at XXXX nm mounted on piezo tip/tilt.

3. Conclusions

The simple design of the proposed system opens possibilities for a straightforward extension in tunability and scaling of pulse energy. The wide tuning range of the Cr:forsterite lasers (from 1150 to 1330 nm) allows DFG generation of mid-IR radiation across a wide spectral interval from 5320 nm to 14220 nm upon proper choice of the nonlinear crystals. The wide accessible spectral range and the narrow-bandwidth open the possibility for variety of applications in fields like medicine and spectroscopy.

References

- [1] Adamczak A, Bakalov D, Stoychev L and Vacchi A 2012 *Nucl. Instrum. Methods B* **281** 7276
- [2] Stoychev L I et al. 2020 *Opt. Letters* **45** (19) 5526