

Design and Application of Microcontroller-Based Tunnel Construction Environment Monitor

Fengyu ZHANG, Biao HU*

Abstract: With the country's strong support for infrastructure, tunnel-related projects are also increasing daily. Combined with the current Internet of Things (IoT) technology booming, the realization of intelligent construction has become the mainstream direction of today's tunnel construction. This design is mainly realized by combining IOT communication technology, sensor technology, and microcontroller technology. STM32 microcontroller acts as the system's central processing unit and receives real-time information on gas concentration, smoke concentration, pipe wall pressure, and water level collected by various sensors, then displays the data on the LED display after data processing. When the environmental data exceeds the standard, it will automatically drive and adjust the water pumps and fans and simultaneously move the WiFi module to remotely send the data to the mobile phone APP through the Internet cloud server. When the environmental data exceeds the standard, it automatically drives and adjusts the water pump and fan while moving the WiFi module to remotely send the data to the cell phone APP through the Internet cloud server. After actual testing, the system can meet the design requirements and further improve the safety and convenience of tunnel construction.

Keywords: internet of things; sensors; STM32 microcontroller; WiFi module

1 INTRODUCTION

Tunnel construction monitoring is mainly applied to tunnel smoke, water level, wall pressure, and gas concentration monitoring, which can prevent fire, flooding, and structural deformation in tunnel construction caused by the loss of life and property. Tunnel detection systems can do real-time monitoring and early detection of problems, early alarm, and timely problem-solving to kill the danger in the cradle (Maxwell & Grasmick, 2021). Tunnels are in the underground environment for a long time. If not monitored after a long time, there may be a risk of cracking and collapse, and once encountered in torrential rainfall weather, tunnel drainage ditches may be poor drainage. The amount of water in the tunnel is too high (Wen et al., 2022), so the tunnel construction workers in the scene may be at risk of drowning, so there is a need for real-time monitoring of the tunnel digging. Therefore, it is necessary to monitor in real-time the accumulation of water in the tunnel excavation and drainage ditches. Part of the tunnel construction may need to cross the coal mine layer due to the high concentration of gas in the coal mine layer, which will threaten the safety of the construction workers and may explode at any time, so before and during the construction, it is necessary to monitor the current gas content of the tunnel in real-time, to ensure that the tunnel construction workers carry out their work in a safe environment (A & B, 2022). Real-time monitoring of tunnel construction is essential. Through the monitoring, the author can understand the current health status of the construction tunnel.

2 RESEARCH BACKGROUND

Countries such as the United States and Japan are in an advanced position in terms of research and design to ensure safe tunnel construction, and at the same time, attach great importance to the research and development of information technology design and application in the construction process (Xue et al., 2021). The survey and geological conditions of underground and tunnel engineering are becoming increasingly complex. The research and

application of the technology is an inevitable trend of development in construction engineering, coupled with the progress of Internet technology and sensor technology, which provides an essential foundation for today's tunnel construction and building (Zhu et al., 2022). Developed countries have accumulated more experience in the construction of underground tunnel projects, and their status in the international community is also more prominent. The developed countries have more experience in tunnel underground engineering construction and are more pronounced in the international community. Especially in Europe and Japan, tunnel monitoring technology began to develop tunnel environmental monitoring management systems based on the information design the enterprise had earlier in industrialization (Pan, 2022). Japan, in about 1970, created a tunnel excavation image analysis system. The system can be through the geological image processing technology on the excavated tunnel surrounding rock analysis and then by optimizing it to adapt to the environment. Like many industries, China's development in tunnel monitoring is characterized by a late start. There is a particular gap compared to developed countries, and the initial growth could be faster. In the initial stage, China studies the structural design of tunnels and construction programs while ignoring tunnel monitoring technology and research development. On the other hand, tunnel environmental monitoring technology's importance in considering the research issue is insufficient (Ou et al., 2021). The degree of importance of the monitoring technology is not high. The monitoring of the technology is not strict. It is not easy to implement the place on the actual construction site.

Compared with traditional monitoring methods, IoT technology can improve work efficiency to a certain extent (Wagner, 2021). However, by analyzing the cases of IoT monitoring at home and abroad, the author can see that they all have some problems and defects:

(1) The automation level of the system's data acquisition, transmission, analysis, and other processes could be higher, requiring much manual intervention.

(2) Low system integration and single function. This is closely related to the hardware devices in the IoT sensing

layer. For example, if too few types of sensors are selected, less data can be collected, and the application range can be narrower.

3 FUNCTIONAL REQUIREMENTS ANALYSIS

3.1 Functional Analysis

The tunnel construction monitoring system based on IoT technology needs to focus on the following core functions during the design process:

(1) Monitoring the pressure change of the vault and tube wall. This kind of construction data needs to be transmitted online in real time to prevent the risk of collapse (Zhang et al., 2021). Therefore, when the pressure sensor monitors abnormal data, the alarm device can issue an alarm in time, and due to the complexity of the tunnel construction environment, the highly penetrating buzzer is selected as the alarm.

(2) Monitor the gas concentration in the tunnel. When the gas concentration sensor senses that the gas concentration exceeds the set threshold, turn on the buzzer alarm and automatically turn on the fan for ventilation (Weinrauch et al., 2021). The gas in the air is blown away in time to reduce the risk factor.

(3) Monitor the water level in the drainage ditch and undercutting in the tunnel, especially when encountering heavy rainfall. It is more important to pay attention to the change of water level in real time (Asmus, 2022). When the data sensed by the ultrasonic sensor is abnormal, it is considered that flooding occurs, and the alarm is given through the buzzer.

3.2 Program Options

3.2.1 STM32 Microcontroller

The design chooses the STM32 microcontroller as the most miniature core control system. This type of microcontroller can be compatible with various functions and low power consumption, which has a significant advantage in developing products. The microcontroller also carries several functions, such as the UART interface communication and timer interrupt, AD conversion, SPI interface, etc.

3.2.2 Wireless Communications

In the wireless communication function, the ESP8266WiFi module is selected. The module has an integrated communication chip and has completed the network communication protocol and built-in low-power consumption (Jiang et al., 2021). The use of the process requires only a small number of peripheral circuits so that the designer in the development of the design is more convenient but also reduces the space occupied by the memory (Zhang, P. 2021). It can be used in many application scenarios, applicable to the operating temperature and environment. The digitized peripheral interface also brings much convenience to the design (Ahin et al., 2022). The digitized peripheral interface also brings much comfort to the plan.

3.2.3 Display

They are designed to select the LED screen as a display medium. Due to the fact that the LED screen size application in the model is not very suitable, so in the physical model design of the selected TF display, the creation of the selected display is a TFT display, to a certain extent, to get rid of the bare screen welding difficulties, and the screen itself with the design of the relevant through the interface and the power supply interface, a more concise and modular to meet the design requirements, the integrated Screen performance is also more stable (Baykal et al., 2022). The display is not light but can control its fixed pins to promote its light. The screen has the outstanding characteristics of the color display, in line with the current diversified features. In the design process, the screen display interface SPI interface is more suitable for designing other modules of the overall performance. In addition, the screen can also directly display Chinese characters (Yahao et al., 2023). so that the need to show the contents of the Chinese characters and numbers can be now combined with the display, and the use of the SPI interface can be quickly driven, enhancing the performance of the integrated screen. In addition, the screen can directly display Chinese characters so that the content can be directly displayed in a combination of Chinese characters and numbers, and the use of an SPI interface can be quickly driven to enhance the overall design performance.

3.2.4 Sensors

Expand the range of sensors to include air quality indices and particulate matter sensors, in addition to the current SnO_2 smoke and gas sensors, to provide a comprehensive safety overview. As the combustible gas content in the atmosphere increases, its conductivity increases. This sensor is characterized by high sensitivity, low cost, and can detect combustible gases. A pressure sensor is mainly through the thin-film pressure strain resistance to detect the pressure, and this sensor has high sensitivity, fast response speed, can detect the pressure change of the tunnel wall promptly, and has a more comprehensive range of measurement (Li et al., 2021). The hardware and software design process is more straightforward, highly stable, and suitable for long-time tunnel use in this environment. To detect whether there is an obstacle more accurately, to ensure the safety of traveling, and to facilitate the use of the user, the ultrasonic distance measurement module is chosen to measure the distance between the obstacle and the target. When sending and receiving ultrasonic waves, the actual distance is calculated using the principle of time and the speed of sound propagation. The module has long mileage, high accuracy, and a high comprehensive price ratio. The gas concentration sensor has a relatively low electrical conductivity, which changes with the gas content in the air. When the amount of combustible gas in the air becomes more extensive, the electrical conductivity of this sensor also becomes higher to detect its specific content. The sensitivity of this sensor is relatively high, and the detection results are very accurate and suitable for detecting combustible gases.

4 SOFTWARE DESIGN OF THE SYSTEM

4.1 General Program Flow Design

After starting the power supply, enhance the system's data processing capabilities by incorporating machine learning algorithms for predictive analysis, enabling the identification of risks before they become critical, in addition to the initial component initialization and WiFi connection. On this basis, the system starts to cycle. It warns the construction environment by detecting the amount of environment collected by each sensor and displaying the collected data in real-time through the Display display. If an alarm is triggered, the corresponding actuator is turned on, the buzzer alarm is turned on, and it determines whether a key is pressed. If pressed, adjust the alarm threshold and save it to the system. Finally, detect whether it receives the on and off commands in the app, turn on and off the corresponding actuators according to the authorities, and perform the work in this cycle.

4.2 Display Driver Design

TFT display driver, mainly through the microcontroller SPI interface, sends data to control the content of the display, calls the display function first needs to initialize the Display internal registers, enter the display state, and then write the window size to the records, that is, to fill the coordinates of the location of the data in the specified coordinates (Zhen, 2021). In turn, fill in the need to show the color, through the restricted area matrix fill in the color of the final display of the text or pattern. The display function is mainly divided into the string display function for the upper application function, write read this for the bottom position; the upper part calls the bottom function to ultimately realize the microcontroller and display hardware registers between the data communication (Kumkratug, P. 2021).

4.3 MQ Series Sensor Driver Design

The MQ2 smoke sensor and MQ7 gas concentration sensor use ADC acquisition, the microcontroller underlying driver through the microcontroller internal ADC acquisition. First of all, the author needs to initialize the ADC and the acquisition bit according to the need to collect the accuracy of the configuration. The relevant parameters include the acquisition speed and the number of injection groups, the design of the acquisition of the accuracy requirements, and the 12-bit accuracy of the addition of conversion. This design has stringent requirements for acquisition accuracy. It adopts the 12-bit precision acquisition and conversion method with high stability. However, it is still difficult to avoid the problem of error drift encountered in the purchase because the error cannot be avoided. Therefore, a single data acquisition is not scientific, cannot be used as a basis for use, and is not counted in the calculation. This design adopts the filtering calculation method through the timed acquisition and timer acquisition; according to the frequency of 100 data per second, the collected data will be stored in the ADC data preservation group. After that, the sorting algorithm functions to sort the data group according to the order of the smallest to the largest, then sort the data with the sorting

algorithm. Sort the data, remove the most significant and minor numbers, the remaining value to get the average value, and then add this value to the calculation equation. The deal is then incorporated into the calculation equation for extrapolation.

4.4 WiFi Receive Data Programming

The WiFi module is an essential key to connecting to the network. The overall function also occupies a critical position; the device to connect to the web can be more significant to enhance the practicality, but also, at this stage of society, it must not be a good one of performance. WiFi is used to receive and send data to the cell phone. Module according to the established provisions of the data to be sent according to the protocol packaged package, in the UART communication will be transmitted to the module, for the data is automatically sent to the preset part of the transit server without the need for developers to study and analyze the contents of the internal with a complete TCP / IP protocol, without the need to send additional transit. This function can be realized by controlling the UART communication interface, data transmission, and output timing. Since the data is received in burst mode, the burst mode is prone to data loss and chaos in the cyclic situation. The UART interrupt mode prevents the primary cycle program's interference. The module will store the received data in an interrupt instruction cache and then analyze the data after transmission to get the instruction.

4.5 Ultrasonic Detection Driver Design

The ultrasonic sensor driver is mainly realized by the external interrupt and internal timer of the microcontroller. First of all, the microcontroller initializes the internal timer and external interrupt, and after initialization, the start pin of the microcontroller is used to start the high level pulse trigger signal to create the ultrasonic module for that measurement; the ultrasonic module will send out ultrasonic alerts, and it will rebound when it meets the obstacle, so as to make the reception of ultrasonic module. The ultrasonic module will send out ultrasonic signals, which will bounce back when it encounters a block, so that the receiving tube of the ultrasonic module receives the signal and outputs the time difference in the high level time, while the microcontroller calculates the duration of the high level through a combination of interrupts and timers, so as to inversely find out the distance between the module and the reflective surface, thus completing the ranging and reminding the user of the obstacle in front of him.

4.6 Alarm Driver Design

The Buzzer alarm driver, used for the microcontroller pin level control function, is the primary function of microcontroller programming, mainly through the program to control the high and low levels of the microcontroller pin. The high level corresponds to the buzzer opening, and the low level corresponds to the closing. To realize control of the high and low levels of the microcontroller pins, the first thing to do is to set the microcontroller pins to the output state, set the output frequency of the nails and the

initialization of the clock, and then after setting up the default output to a low level, so that the buzzer is turned off, use the if statement to determine whether to turn on the buzzer. Then, when there is an alarm signal, it is judged necessary to send one, which will convert the microcontroller pin level from low to high, and the buzzer will turn off the buzzer. The pin level of the microcontroller is converted from low to high, and the buzzer sounds an alarm immediately.

4.7 Relay Driver Design

For relay-driven fans, realizing this part of the drive is to complete the microcontroller process controlling the pins' high and low-level changes. Before using the microcontroller to control the nails, the first step is configuring the registers inside the staples to start the pins accordingly and then setting the pins' frequency and position. Moreover, when controlling the drive, it is necessary to have a significant output power, so the author chose push-pull when selecting the output method. The preset initialization state of the pins is a low level, which indicates that the actuator is to be switched off, and then, based on the microcontroller's operation program, decide whether to convert the pin level to a high level, it indicates that the manipulator is turned on.

4.8 Pressure Sensor Driver Design

The pressure measurement designed in this project uses a microcontroller's ADC for data acquisition. The initialization data acquisition bits of the ADC must be set based on the required data acquisition accuracy of the tunnel pressure. Regarding the number of injection groups and the sampling rate, the 12-bit data accuracy is higher than the speed requirement, so the 12-bit data accuracy is low, and the stability is high. However, the ADC still suffers from error drift in sampling. Therefore, a single sampling value is not included. On this basis, the author uses a filter-based algorithm that uses a timer to take measurements periodically, collects 100 data per second, saves the sampled value to the ADC data in the array, and then calls the sorting algorithm function to sort the data, removes several values at the ends of the size, respectively, and averages the remaining intermediate values, and then finds the practical value.

4.9 Key Monitoring Driver Design

The microcontroller pins also operate the key monitoring driver, setting the corresponding pins' registers according to the desired pins' functional requirements. The design configures the essential function so that the system is equipped with manually adjustable thresholds and other related indicators, making the method applicable to various environments and expanding the system application scenarios. Because in this design, the button is using a low level to detect the pressed state, the pin mode required for the controller is the pull-up mode; under normal circumstances, the state of the pin is a high level, and the main loop in the order of non-stop checking the hook, when the button is pressed, the level signal of the pin will go from high to low, to determine that it is the button that is demanded.

4.10 APP Programming

Design an APP program with Eclipse software. First of all, eclipse configures the Android development environment to create a tunnel construction monitoring project to enter the project information after the completion of a first-scale project has been built. After that, all the program codes required for the app are written in the files under the src directory, and the layout of the app display interface is edited in the files under the res directory.

The system is a combination of multiple hardware circuit parts, through the coordination of the functions of each hardware part, to achieve the overall functional requirements in the completion of the integrated hardware circuit part of the building. However, it also needs to inject the soul of the system in terms of software so that the system becomes an organic whole. To achieve the stability of the function, from the macroscopic overview to the microscopic, each single-component driver is introduced, as well as the tasks that need to be achieved. From the macro-overview to the micro drivers of each single component, respectively, and the need to realize the functions.

5 HARDWARE DESIGN OF THE SYSTEM

Moreover, to enhance the system's robustness and reliability in harsh tunnel environments, protective measures or materials will be integrated into the hardware design to shield the microcontroller and sensor modules from dust, water, and mechanical impacts. The microcontroller is responsible for providing the hardware to collect the data of each module and the control of the module. Also, it shows the details of the circuit connection of each module.

5.1 Control Unit: Introduction to STM32

The design chooses the STM32 microcontroller as the minimum core control system. The type of microcontroller is a standardized microcontroller structure; it has a significant advantage in developing products. The microcontroller also carries a UART interface communication, timer interrupt, AD conversion, and other functions. The integrated chip on the minimum core system covers various tasks that can reduce power consumption and improve stability for the overall design. Download and use the program using jlink for debugging online running simulation, and it is easy to use. In addition, the development program also has a breakpoint to find a powerful function of the bug placement, which can minimize the development and design time and reduce the error rate. Small in size and powerful.

5.2 Introduction to the Minimum System

The core architecture of the STM32 microcontroller is ARM-M3, which is more advanced, has faster operation speed, relatively low power consumption, and high stability. Designed to use the STM32 microcontroller as the smallest core circuit board, the core circuit board has been realized inside the microcontroller and can be regular operation of the minimum components required. The first is the voltage regulator circuit the system power supply 5V regulator into 3.3 for microcontroller use. The second is the clock circuit, through the external crystal circuit, to achieve

the microcontroller operation to provide a clock synchronization signal. The third is the reset circuit, which can reboot the system to get it running again. The fourth is the boot option, which selects whether to run the program from the internal RAM area or the Flash memory area of the STM32 microcontroller. The circuit diagram of the STM32 microcontroller minimum system is shown in Fig. 1.

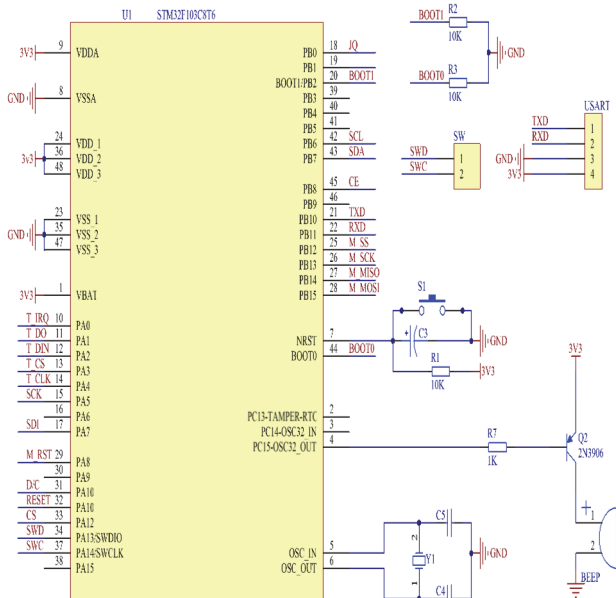

Figure 1 STM32 microcontroller minimum system circuit diagram

5.2.1 Power Supply Circuit Design

The author must design a reliable power supply line to ensure the system's stability, so the author chose the AMS1117-3.3V regulator chip. This chip uses the LDO voltage regulator principle. People can output a relatively high-quality power supply to reduce the impact of power supply noise. Integrating a filter capacitor in the chip's input and output enhances the system power supply's dynamic response, further improving its stability. Additionally, a current limiting resistor and an LED indicator are incorporated to provide a visual indication of the regularity of the system power supply. A current-limiting resistor and a LED indicator indicate whether the system power supply is standard to enhance the system's strength further. The voltage regulator circuit composed of this chip is relatively simple. Only the filter capacitors must be connected in parallel on both the input and output sides. The circuit diagram is shown in Fig. 2.

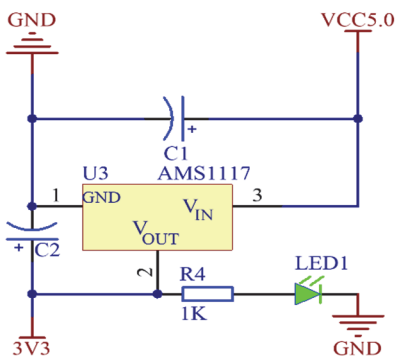

Figure 2 Power supply circuit diagram

5.2.2 Crystal Circuit Design

The crystal oscillation circuit is mainly designed to provide the temperature of the time so that the microcontroller can run the program stably and play a vital role in the system, so choose to use an external crystal oscillation device with two starting capacitors. To create the vibration, the capacitor selected is 22 pF, and the chosen crystal is 8 MHz, five elements of the vigilance oscillator. The circuit diagram is shown in Fig. 3.

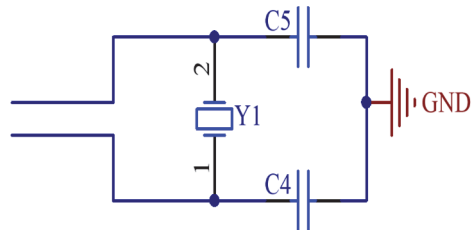

Figure 3 Crystal circuit diagram

5.2.3 Reset Circuit Design

The reset circuit can restart the system, which can allow the system to run the program without breaking the power supply and troubleshoot the problem. The reset circuit is mainly composed of capacitors, resistors, and keys, and resistors are used primarily for pull-up and will control the voltage at 3.3V to ensure that the normal will not be reset when the key is pressed. The MCU reset pin is connected to the negative GND to achieve the effect of reset. The capacitor's primary role is to eliminate the jitter placed in the pressed key after the jitter produces multiple resets. The reset circuit is shown in Fig. 4.

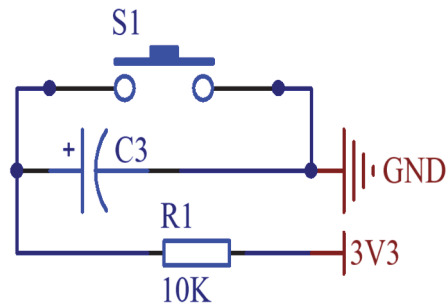

Figure 4 Reset circuit diagram

5.3 Display Interface Circuit

To be more convenient and intuitive monitoring of relevant data and indicators, the design adds a display screen to provide display functions and improve the overall performance of the practicality. The method of the selected display is a TFT display, the screen to a certain extent to get rid of the bare screen welding difficulties, and the screen itself with the design of the communication interface and power supply interface, more concise and modular to meet the design requirements, the integration of the screen performance is also more stable. The display itself is not light-emitting, but through the circuit of the TFT-TFT pin to control the backlight function of the show, through the backlight board TFT backlight processing, the need for the pin in parallel with a 10 Ω resistor to the power supply, the power supply of the screen is also 3.3V; the

circuit diagram of the TFT-SCK pin is a signal pin, connected to the data bus SPI, TFT-SDA is a data pin. SDA is a data pin connected to the data bus SPI, and the microcontroller sends the relevant instructions, and data to the screen is completed through these two data bus signals. The circuit is shown in Fig. 5.

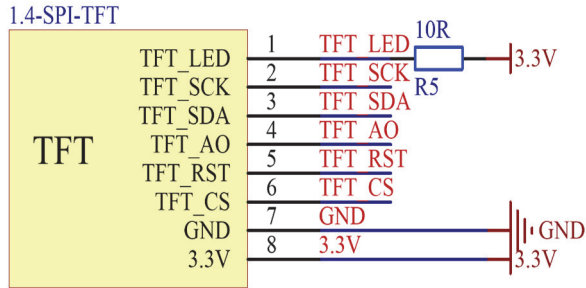

Figure 5 LED display interface circuit

5.4 MQ Series Sensor Detection Circuitry

The MQ2 smoke sensor and MQ7 gas sensor circuit principle are essentially the same: to measure the concentration of the environment to be detected, the power supply is 5V. It belongs to the direction of the chemical-electrical effect, for example, the smoke sensor. When there is no smoke within the environment, the sensor is in a high resistance state; when in the environment appears smoke, it will show linear change. The sensor has four pins. Pin 1 and 2 is the power supply pin, respectively, connected to the 5V and GND; the DO pin and AO pin is the sensor's output pins. DO pin outputs digital exchange of signals. AO pin outputs the smoke concentration of analog signals; the two roles are different, so to make the AO pins be separated, people need to connect the AO pin with a resistor voltage divider so that the AO pin reads the smoke concentration. Pin to read the smoke concentration can be changed by the size of the smoke concentration and lead to changes in the resistance. After the voltage divider can get that the voltage can be a signal, the signal will change with the strength of the change, and then the microcontroller, through the ADC to collect the sensor voltage quantization of the calculations, can be obtained after the real-time value of the smoke concentration.

5.5 WiFi Module Interface Circuitry

This application module has a total of 8 pins. Pin 1 is connected to the power supply GND, pin five is connected to the 3.3V power supply, and pin eight and pin four are connected to the microcontroller's pins PA8 and PA10, respectively, because the module communicates through the UART interface. Ensuring the stability of network communication is a significant concern that maintains the strength of the ESP8266 module. Maintaining the module's stability needs to deal with the radio magnetic generated by the WiFi communication process. The design scheme of connecting filter capacitor C8 to the power supply can avoid high-energy electromagnetic interference to the greatest extent possible to prevent the interruption of communication signals and other problems. The circuit is shown in Fig. 6.

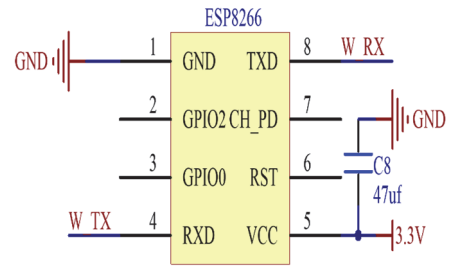

Figure 6 WiFi module interface circuitry

5.6 Ultrasonic Detection Circuit

Ultrasonic detection of objects can prompt the user to avoid obstacles in advance to prepare. The module can measure the distance of obstacles encountered to improve intelligence and user-friendliness. The module has a total of four pins, two of which are the positive and negative poles of the power supply, the choice of 5V voltage for the power supply, EC pin and TR two pins are connected to the module in the microcontroller on the data communication pins, the module and the microcontroller can be completed through the connection of the IO port, the relationship is the microcontroller IO interface. The module is connected to the TR pin and matches the set into the push-pull output mode! To maintain the normal triggering of the module, it needs to ensure that there is a sufficient amount of output. When an obstacle is encountered, the TR pin will detect the block and trigger by abnormal measurements. The EC pin will receive feedback, interrupting the external interface to realize the reception of signals and input and calculating the distance between the object to be measured and the sensor. The ultrasonic circuit design, although extremely simple, is powerful enough to meet the requirements of the designed construction monitoring system.

5.7 Alarm Circuits

The design system is matched with an alarm circuit, more than the preset threshold, which will alert the user through the sound of the alarm, making the use of equipment more convenient. In contrast, the notice can be perfect for the user to provide early warning information, real-time mastery, and real-time grasp of the dangerous state of the construction site. The system buzzer selection of active buzzer and transistor selection of NPN-type play a role in the circuit to amplify the control current. The base of the transistor cannot be directly connected to the microcontroller pins; otherwise, it will lead to pin overcurrent damage. The bottom of the transistor cannot be directly related to the microcontroller pin. Otherwise, it will lead to overcurrent damage. In order to lower the microprocessor pin current, we need to series a 1 K resistor. The emitter of the triode is connected to the negative terminal, the collector is connected to the negative terminal of the buzzer, and the positive terminal is connected to the 3.3V supply to form a common-emitting amplifier. When the alarm is required to be switched on, the pin of the microcontroller sends out a high-level signal, which then turns on the transistor through the action of the resistor, thus controlling the buzzer sound. When the alarm is requested to be deactivated, the microcontroller outputs a low voltage, the triode cuts off, the power to the buzzer is turned off, and the buzzer no longer chirps. The circuit is shown in Fig. 7.

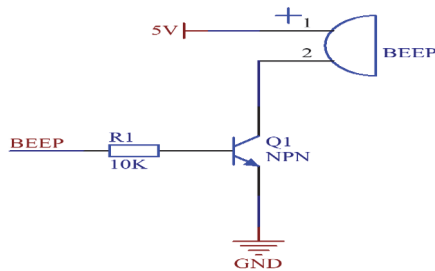

Figure 7 Alarm circuit

5.8 Pressure Sensor Detection Circuit

A thin-film pressure sensing circuit using a thin-film pressure sensor, 10 K resistor, and 104 capacitor composition, the thin-film pressure sensor can change with the change in pressure and its resistance value. When the thin film pressure sensor R21 resistance changes, its and R20 resistance voltage divider circuit make the Pre end to the microcontroller ADC acquisition pin voltage changes through the voltage inverse resistance value, and then by the resistance to the pressure of the corresponding relationship can be obtained from the deal of the stress, which C20 is used as a filter, to prevent the generation of voltage noise. The sensitivity of this sensor is very high, suitable for this tunnel construction monitoring model application. At the same time, this sensor cost is not high. The operation is simple. The detection data is relatively more accurate. The circuit diagram of the thin film pressure sensor is shown in Fig. 8.

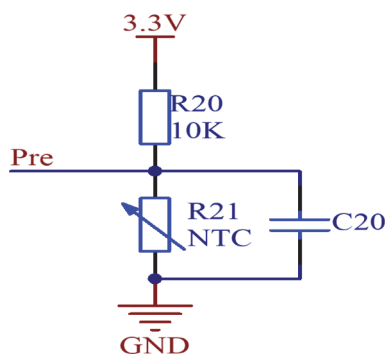

Figure 8 Pressure detection circuit

The design system consists of various modularized parts, the method of connecting each module used, and the overall hardware architecture. The design of the system is composed of multiple modularized parts. In the hardware design of each component, the focus is on the circuit connection of each module and the function of each pin. The design is simple, and the procedure is complete.

6 SYSTEM COMMISSIONING

6.1 Hardware Debugging

To debug each module, first check whether the power supply of each module is regular. People can use a universal board to measure the voltage of the power supply pins and then test the signal pins and control pins connected to the microcontroller to determine whether the corresponding, such as the display, should be connected to the microcontroller's SPI interface, smoke sensors, gas concentration sensors, pressure sensors, circuitry coupled

to the microcontroller's ADC interface. The WiFi module is connected to the microcontroller UAR interface, each interface pin should be connected correctly according to the microcontroller data manual to carry out standard communication control and receive data. The WiFi module is connected to the UAR interface of the microcontroller. Each interface pin should be connected correctly according to the data manual of the microcontroller to carry out standard communication control and receive data. If any module fails to work correctly, people should first use a multimeter to check whether any pin of the module has been shorted or disconnected, and then carefully check whether each pin is correctly connected to its corresponding pin of the other module. After checking out the error, people must carry out a power-off process, and then connect it to the correct pin. If there is still a module for regular operation, people must check whether the circuit has a standard circuit loop; if not, the author must weld it into a typical course. At the same time, the author must weld to the soldering point of the rounded and uniform to ensure that the pins will not appear the phenomenon of false connection, so our system can operate normally to reduce some of the debugging workload.

6.2 Software Debugging

Following the functions required in advance to write an excellent corresponding program, and then compile the program, according to the compilation results to troubleshoot problems, locate the problem code, according to the prompts for modification, until the compilation is error-free, compiling error-free after the download program, the microcontroller core board through the link downloader and the USB connection to the computer, click on the download debugging run in the Keil, run the program to see the results of the run to meet the design expectations. Design expectations, followed by the need to debug the serial port and network debugging assistant configuration, the choice of COM following the computer generates the corresponding bit rate can be, in the multiple send command box, enter the AT command, configure the module for the station mode, after the completion of the configuration of the device will automatically connect to the WiFi hotspot after power-up combined with breakpoints to view the variable content, in the problem code at the single-step running step by step debugging, combined with debugging results for further modification, repeat the above operations until the expected demand.

System design and architecture are essential in the early stage, and debugging is also an indispensable part of the later stage. The debugging of the system determines whether the system's functions can operate normally and whether the system is perfect. First of all, the debugging of the power supply stability. The design of a power supply is first to ensure that the power supply is stable, which is a necessary condition for a perfect system. Second is the core of the microcontroller debugging. A microcontroller is the heart of the whole system operation and has a vital role, so the author must debug it individually to check whether its functions can be expected over the procedure. After the module welding check is also an essential part, only the module welding is not a problem to continue a series of later operations, and welding is a test of our expertise so

that the author can be smooth. At the same time, the communication module is an essential step in determining whether the APP can complete real-time communication with the microcontroller. The hardware part of the end of the debugging and the software part of the debugging are also worth noting in the link. First, use Keil software to normally debug the internal program of the microcontroller. Then, write an app program with Eclipse software and follow StepStep to debug it.

7 CONCLUSION

The development of a microcontroller-based monitoring system for tunnel construction environments represents a significant step forward in the integration of Internet of Things (IoT) technology into infrastructure projects. Our system leverages the STM32 microcontroller, sensors for various environmental parameters, and wireless communication to provide real-time monitoring and control, ensuring the safety and efficiency of tunnel construction.

Through rigorous testing and application, the system has proven capable of monitoring critical parameters such as gas concentration, smoke levels, pipe wall pressure, and water levels, triggering automatic responses to prevent accidents and structural failures. The incorporation of machine learning algorithms and enhanced data processing capabilities has laid the groundwork for predictive analysis, further augmenting the system's ability to preemptively address risks.

Despite these advancements, our research underscores the need for continued improvement in several key areas. Future iterations of the system will aim to expand sensor range to cover air quality indices and particulate matter concentrations, enhance energy efficiency and system longevity, and improve user interfaces for better accessibility. Moreover, compatibility with existing construction management software and the consideration of environmental sustainability in hardware design will be crucial in broadening the system's applicability and minimizing its ecological footprint.

The microcontroller-based tunnel construction environment monitoring system embodies a promising convergence of traditional construction practices and modern IoT technology. It not only meets the current demands of tunnel construction safety but also opens avenues for technological advancements that could revolutionize infrastructure development practices.

8 REFERENCES

- [1] Bauduin, A. C. & Kirstein, A. A. (2022). Design, construct and monitor an underwater retaining wall close to an existing immersed tunnel. *Tunnelling and Underground Space Technology*, 120, 104311. <https://doi.org/10.1016/j.tust.2021.104311>
- [2] Ahin, A., Hoque, S. S. M., & Chen, C. Y. (2022). Index Modulation With Circularly-Shifted Chirps for Dual-Function Radar and Communications. *IEEE Transactions on Wireless Communications*, 5, 21. <https://doi.org/10.1109/TWC.2021.3117063>
- [3] Asmus, S. (2022). A new in-situ method to drive advances in concrete tunnel construction. *Concrete*.
- [4] Baykal, Y., Ata, Y., & Gokce, M. C. (2022). Underwater turbulence, its effects on optical wireless communication and imaging: A review. *Optics & Laser Technology*, 33(34), 45-53. <https://doi.org/10.1016/j.optlastec.2022.108624>
- [5] Jiang, S., Li, J., Leng, T., & Wang, R. (2021). Study on Design of Novel Function/Structure Integration Mounting Plate for Space borne SAR Antenna for Wireless Communication. *Journal of Physics: Conference Series*, 34(23), 33-50. <https://doi.org/10.1088/1742-6596/2083/2/022095>
- [6] Kumkratug, P. (2021). Simulink Block Diagram of Sixth-order Model for Power System Dynamic Study. *European Journal of Electrical Engineering and Computer Science*, 6(4), 1-17. <https://doi.org/10.24018/ejece.2021.5.4.338>
- [7] Li, S., Pang, J., Wu, Q., Yao, N., & Yuan, W. (2021). Transfer learning based attack detection for wireless communication networks. *Concurrency and Computation Practice and Experience*, 1.
- [8] Maxwell, A. & Grasmick, J. (2021). Quantification of tangible and intangible benefits of digitalization in tunnel construction. *Mining Engineering*, 3, 73.
- [9] Ou, G. Z., Jiao, Y. Y., Zhang, G. H., Zou, J. P., & Zhang, W. S. (2021). Collapse risk assessment of deep-buried tunnel during construction and its application. *Tunnelling and Underground Space Technology*, 115(3), 104019.
- [10] Pan, T. (2022). Influences of double-track shield tunnel construction on settlements of adjacent ground and buildings in a soft soil area. *Hydrogeology & Engineering Geology*, 49(1), 101-108.
- [11] Tan, X., Wang, Y., Du, B., Ye, J., Chen, W., Sun, L., & Li, L. (2021). Analysis for full face mechanical behaviors through spatial deduction model with real-time monitoring data. *56(55)*, 23-40.
- [12] Wagner, H. (2021). Review of the "Tunnel Seismic While Drilling" measurements during construction of the Koralm Tunnel at section KAT2. *Geomechanics and Tunnelling*, 23(23), 45-56.
- [13] Weinrauch, A., Seidel, H. P., Mlakar, D., Steinberger, M., & Zayer, R. (2021). A Variational Loop Shrinking Analogy for Handle and Tunnel Detection and Reeb Graph Construction on Surfaces. *567(567)*, 346-.
- [14] Wen, T., Hu, Z., Wang, Y., Zhang, Z., & Sun, J. (2022). Monitoring and Analysis of Geotemperature during the Tunnel Construction. *Energies*, 15(3), 736-. <https://doi.org/10.3390/en15030736>
- [15] Xue, F., Cai, M., Wang, T., & Zhao, T. (2021). Characteristics of Karst Cave Development in Urban Karst Area and Its Effect on the Stability of Subway Tunnel Construction. *Advances in Civil Engineering*, 2021(4), 1-12. <https://doi.org/10.1155/2021/8894713>
- [16] Yahao, D., Shikh-Bahaci, M., Zhaohui, Y., Chongwen, H., & Weijie, Y. (2023). Secure Federated Learning over Wireless Communication Networks with Model Compression. *ZTE Technology*, 21(1), 46-54.
- [17] Zhang, P., Chen, R. P., Dai, T., Wang, Z. T., & Wu, K. (2021). An AIoT-based system for real-time monitoring of tunnel construction. *Tunnelling and Underground Space Technology*, 109(456), 103766. <https://doi.org/10.1016/j.tust.2020.103766>
- [18] Zhang, X., Huanjun, B. I., Cao, F., & Xia, W. (2021). Characteristics of moisture content variation of loess under seepage and its influence on tunnel engineering. *Hydrogeology & Engineering Geology*, 48(4), 41-47.
- [19] Zhen, L. (2021). An English Mobile Learning Platform Embedded in GSM-R Wireless Network Communication. *Secur. Communication Networks*, 2021(34), 8228300:1-8228300:9. <https://doi.org/10.1155/2021/8228300>
- [20] Zhu, Y., Zhou, J., Zhang, B., Wang, H., & Huang, M. (2022). Statistical analysis of major tunnel construction accidents in China from 2010 to 2020. *Tunnelling and Underground Space Technology*, jun.(Jun.), 124. <https://doi.org/10.1016/j.tust.2022.104460>

Contact information:

Fengyu ZHANG,
College of Engineering,
China Agricultural University,
Beijing 100083, China

Biao HU
(Corresponding author)
College of Engineering,
China Agricultural University,
Beijing 100083, China
E-mail: 13753116809@163.com