

University of Groningen

EEG signals from tinnitus sufferers at identifying their sound tinnitus

Torres-Torres, Alma Socorro; Alonso-Valerdi, Luz María; Ibarra-Zarate, David I.; González-Sánchez, Andrea

Published in:
Data in brief

DOI:
[10.1016/j.dib.2024.110142](https://doi.org/10.1016/j.dib.2024.110142)

IMPORTANT NOTE: You are advised to consult the publisher's version (publisher's PDF) if you wish to cite from it. Please check the document version below.

Document Version
Publisher's PDF, also known as Version of record

Publication date:
2024

[Link to publication in University of Groningen/UMCG research database](#)

Citation for published version (APA):

Torres-Torres, A. S., Alonso-Valerdi, L. M., Ibarra-Zarate, D. I., & González-Sánchez, A. (2024). EEG signals from tinnitus sufferers at identifying their sound tinnitus. *Data in brief*, 53, Article 110142. <https://doi.org/10.1016/j.dib.2024.110142>

Copyright

Other than for strictly personal use, it is not permitted to download or to forward/distribute the text or part of it without the consent of the author(s) and/or copyright holder(s), unless the work is under an open content license (like Creative Commons).

The publication may also be distributed here under the terms of Article 25fa of the Dutch Copyright Act, indicated by the "Taverne" license. More information can be found on the University of Groningen website: <https://www.rug.nl/library/open-access/self-archiving-pure/taverne-amendment>.

Take-down policy

If you believe that this document breaches copyright please contact us providing details, and we will remove access to the work immediately and investigate your claim.

Downloaded from the University of Groningen/UMCG research database (Pure): <http://www.rug.nl/research/portal>. For technical reasons the number of authors shown on this cover page is limited to 10 maximum.



Data Article

EEG signals from tinnitus sufferers at identifying their sound tinnitus

Alma Socorro Torres-Torres^{a,b}, Luz María Alonso-Valerdi^a,
David I. Ibarra-Zarate^{a,*}, Andrea González-Sánchez^a

^a Escuela de Ingeniería y Ciencias, Tecnológico de Monterrey, Monterrey, N.L., Mexico

^b Department of Neurology, University Groningen, University Medical Center Groningen, Groningen, the Netherlands

ARTICLE INFO

Article history:

Received 10 October 2023

Revised 19 January 2024

Accepted 25 January 2024

Available online 1 February 2024

Dataset link: [Characterization of Tinnitus Through the Analysis of Electroencephalographic Activity \(Original data\)](#)

Keywords:

Event-related potentials

Electroencephalography

Sound pitch matching

Tinnitus functional index

ABSTRACT

The present database contains brain activity of subjective tinnitus sufferers at identifying their sound tinnitus. The main objective of this database is to provide spontaneous Electroencephalographic (EEG) activity at rest, and evoked EEG activity when tinnitus sufferers attempt to identify their sound tinnitus among 54 tinnitus sound examples. For the database, 37 volunteers were recruited: 15 ones without tinnitus (Control Group – CG), and 22 ones with tinnitus (Tinnitus Group – TG). For EEG recording, 30 channels were used to record two conditions: 1) *basal condition*, where the volunteer remained in a state of rest with the open eyes for two minutes; and 2) *active condition*, where the volunteer must have identified his/her sound stimulus by pressing a key. For the active condition, a sound-tinnitus library was generated in accordance with the most typical acoustic properties of tinnitus. The library consisted in ten pure tones (250 Hz, 500 Hz, 1 kHz, 2 kHz, 3 kHz, 3.5 kHz, 4 kHz, 6 kHz, 8 kHz, 10 kHz), a White Noise (WN), a Narrow Band noise-High frequencies (NBH, 4 kHz–10 kHz), a Narrow Band noise-Medium frequencies (NBM, 1 kHz–4 kHz), a Narrow-Band noise Low frequencies (NBL, 250 Hz–1 kHz), ten pure tones combined with WN, ten pure tones superimposed with NBH, ten tones with NBM and ten pure tones combined with NBL. In total, 54 sound-tinnitus were applied for both groups. In the case of CG, volunteers must have identified a sound at 3.5 kHz. In

* Corresponding author.

E-mail address: david.ibarra@tec.mx (D.I. Ibarra-Zarate).

addition to EEG information, a csv-file with audiometric and psychoacoustic information of volunteers is provided. For TG, this information refers to: 1) hearing level, 2) type of tinnitus, 3) tinnitus frequency, 4) tinnitus perception, 5) Hospital Anxiety and Depression Scale (HADS) and 6) Tinnitus Functional Index (TFI). For CG, the information refers to: 1) hearing level, and 2) HADS.

© 2024 The Author(s). Published by Elsevier Inc.

This is an open access article under the CC BY-NC-ND license (<http://creativecommons.org/licenses/by-nc-nd/4.0/>)

Specification Table

Subject	Biological Sciences: Neuroscience
Specific subject area	Neuroscience: Sensory Systems, Electrophysiology
Data format	Audiometric and psychoacoustic information – Excel-file EEG recordings in basal condition – Raw (gdf-file) and pre-processed signals (set-file) EEG recordings at identifying tinnitus sound – Raw (gdf-file), pre-processed (set-file), and epoched signals (set-file) Single-trial auditory event related potentials – set-file Tinnitus-sound library – wav-file
Type of data	Biosignal recordings – human brain activity
Data collection	The EEG recordings were acquired by two g.USBamp amplifiers, which were synchronized to have a total of 32 channels. A sampling rate of 256 Hz and less than 5 kΩ electrode-skin interface impedance were set for acquisition. FCz and A1 electrodes were the ground and reference electrodes of the system, respectively. Of the total 32 channels, 30 of them were for EEG recording, and the rest of them were for electrooculography (EOG) recording. The positions of the electrodes were in line with the International 10/20 Standard System.
Data source location	Escuela de Ingeniería y Ciencias, Tecnológico de Monterrey, Monterrey, Nuevo Leon, México.
Data accessibility	All the data is in a public repository described below. Repository name: Mendeley Data Data identification number: 10.17632/fj7sskjd75 Direct URL to data: https://data.mendeley.com/datasets/fj7sskjd75 Version 5 Torres-Torres, Alma Socorro; Alonso-Valerdi, Luz Maria; Ibarra-Zarate, David I (2023), "Characterization of Tinnitus Through the Analysis of Electroencephalographic Activity", Mendeley Data, V5, doi:10.17632/fj7sskjd75

1. Value of the Data

- The database is relevant for studying the tinnitus functional changes in brain networks by the evoked response on identifying a sound that matches the subjective tinnitus. As well as basal brain activity that can be used to describe the ongoing brain activity correlated with a continuous perception of this symptom.
- This data can be used by Data Scientists, Audiologists, and Medical Research Institutes to design, compare, and deploy artificial intelligence models for the development of a computer-aided diagnosis tool.
- This dataset was acquired to characterize subjective tinnitus on the basis on its EEG reaction; and to develop effective treatments that would improve the quality of life of tinnitus sufferers.
- This dataset is the first to achieve the characterization of the psychoacoustics of tinnitus by analysing evoked responses. This unique methodology would allow for the development of an objective diagnosis and characterization methodology, which is lacking in current clinical practice.

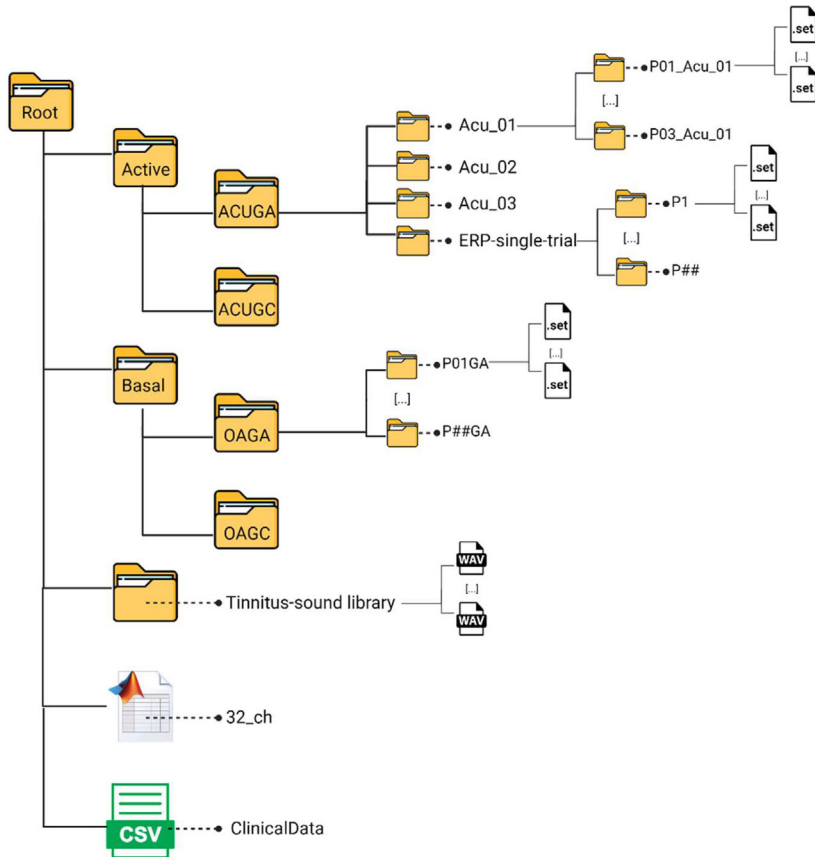

Fig. 1. Data structure in the Mendeley Data repository.

2. Objective

Subjective tinnitus is a symptom associated with the perception of a sound without an external source that generates it. Although its origin is possibly due to a hearing impairment, the perception of this is a brain pathology that causes a decrease in the quality of life of people who suffer from it, having significant morbidity. It has no cure, and alternative treatments remain uncertain.

The main objective of this database was to gather data related to brain activity to characterize tinnitus and to provide a reliable and replicable accurate measurement that reflected the nature of this symptom.

3. Data Description

As is shown in Fig. 1, this section describes the structure of data available in the Mendeley Data repository. In the root folder, the data is divided into three folders regarding the two types of EEG data: 1) Active, 2) Basal, and 3) the Tinnitus sound library, besides two files related to the 4) audiometric and psychoacoustic information, and the 5) topographical distribution of the EEG channels.

3.1. Active

The sound identification step is provided as raw and pre-processed data, and processed Event-Related Potential (ERP) single trials. Raw data is in *gdf*-format, and the rest of information is in *set*-format. Both formats can be read by BioSig. This folder is divided into two sub-folders: Tinnitus Group (TG) and Control Group (CG). In turn, each group is divided into four folders, where *Acu_##* refers to each run of the active mode. The ERP-single-trial folder has each single trial ERP per volunteer ready to be featured and classified. Besides, this folder contains a CSV file containing a binary matrix that indicates the stimulus that the subject selected during the active paradigm.

3.2. Basal

Raw and pre-processed basal data are provided for each patient in *gdf* and *set* formats. This folder is divided into two folders related to each study group.

3.3. Tinnitus-sound library

The sounds that were generated for TG are located in this folder in *wav*-format: 10 pure tones (250 Hz, 500 Hz, 1 kHz, 2 kHz, 3 kHz, 3.5 kHz, 4 kHz, 6 kHz, 8 kHz, 10 kHz), a White Noise (WN), a Narrow-Band noise-High frequency (NBH, 4 kHz–10 kHz), a Narrow-Band noise-Medium frequencies (NBM, 1 kHz–4 kHz), a Narrow-Band noise-Low frequencies (NBL, 250 Hz–1 kHz), ten pure tones combined with RB, ten pure tones superimposed with NBH, ten tones with NBM, ten pure tones combined with NBL and a silence recording. The functions were programmed under a MATLAB (version 2022b) programming environment. CG sounds were overlaid with a pure 3.5 kHz tone to emulate tinnitus sound.

3.4. EEG channel location

This file contains the file location of the topographical distribution of EEG channels. FCz and A1 electrodes were the ground and reference electrodes of the system, respectively. Of the total 32 channels, 30 of them were for EEG recording, and the rest of them were for electrooculography (EOG) recording. The positions of the electrodes were in line with the International 10/20 Standard System.

3.5. Audiometric and psychoacoustic data

This *csv*-file contains the audiometric and psychoacoustic information of each volunteer, providing the following fields for TG: 1) hearing level, 2) type of tinnitus, 3) tinnitus frequency, 4) tinnitus perception, 5) HAD and 6) TFI. For CG, only two fields are provided: 1) hearing level, 2) HADS.

4. Experimental Design, Materials and Methods

4.1. Sample size calculation

Despite the data being acquired during the COVID-19 pandemic shutdown, the number of recruited participants was limited. To determine enough participants needed to detect potential

EEG biomarkers characterizing the presence of tinnitus, a sample size calculation was implemented according to equation (1) that allows finding the minimum sample size per group (n) when the goal is to compare and average continuous variable between two populations [1].

$$n = 2 \frac{(z_{\alpha} - z_{\beta})^2 \sigma_{CG}^2}{(\mu_{CG} - \mu_{TG})^2} \quad (1)$$

In the equation:

- z_{α} is the two-tailed z-value from a 95 and 99% confidence level.
- z_{β} is the one-tailed z-value from the power 80 and 95%.
- μ_{CG} is the mean from the control group (CG).
- μ_{TG} is the mean from the tinnitus group (TG).
- σ_{CG} is the control group (CG) standard deviation.

The variable used to estimate the optimal sample size was EEG Power Spectral Density (PSD) on gamma oscillations (30–90 Hz) at resting state with open eyes, on channels T7 and T8 because the temporal lobes have been reported as a relevant brain cortex areas to distinguish tinnitus from controls in previous research [2]. PSD on gamma has been reported as an accurate biomarker for aberrant gamma oscillations in central nervous system diseases like hearing impairment [3] and tinnitus [4]. To obtain the mean of each group, EEG data of tinnitus patients and control subjects were obtained from an EEG database of 103 participants [5]. For the CG, the mean (μ_{CG}) was $0.645 \mu V^2$ with a σ_{CG} equal to $0.421 \mu V^2$. For TG the mean (μ_{TG}) was $1.183 \mu V^2$, therefore the $\mu_{TG} > \mu_{CG}$ which corresponds with the expect increase of gamma oscillations on the continuous perception of a sound of tinnitus subjects [6,7]. According to equation (1), for a power of 80% and 95% of confidence level $n = 10$ and for a power of 95% and 99% of confidence level $n = 22$. Therefore, the main goal was to recruit between 10 and 22 participants per group. Because the COVID-19 pandemic shutdown was hard to recruit the participants, especially for the CG. On the other hand, recruiting TG participants was relatively quicker because almost all chronic tinnitus sufferers experience a worsened perception of tinnitus.

4.2. Audiometer AD226

The Interacoustics audiometer (AD226) was used to perform tonal audiometry (TG and GC) and subjective tinnitus pitch matching (TG) at the beginning of the experimental procedure. The AD226 audiometer is a hybrid diagnostic audiometer from the Interacoustics company. It measures the full hearing range, reaching a maximum output of 120dBHL across most frequencies. Offering versatility, it includes “dual calibration” for two earphone sets. Additionally, the audiometer includes bone conduction and masking for diagnostic audiological testing, making it a comprehensive solution for immediate or future use. [8].

4.3. SHURE headphones

Professional hearing aids with extended frequency response were used to manage sounds in the experimental paradigm, allowing an accurate audio signal to be reproduced over a wide range [9]. The use of SHURE hearing aids guaranteed that the reproduced sounds maintained their acoustic properties, essential for the proper identification of sounds by the participants, the intensity of each frequency was adjusted according to the hearing level of each band + 10 dB, and the volume according to the level of perception of each participant.

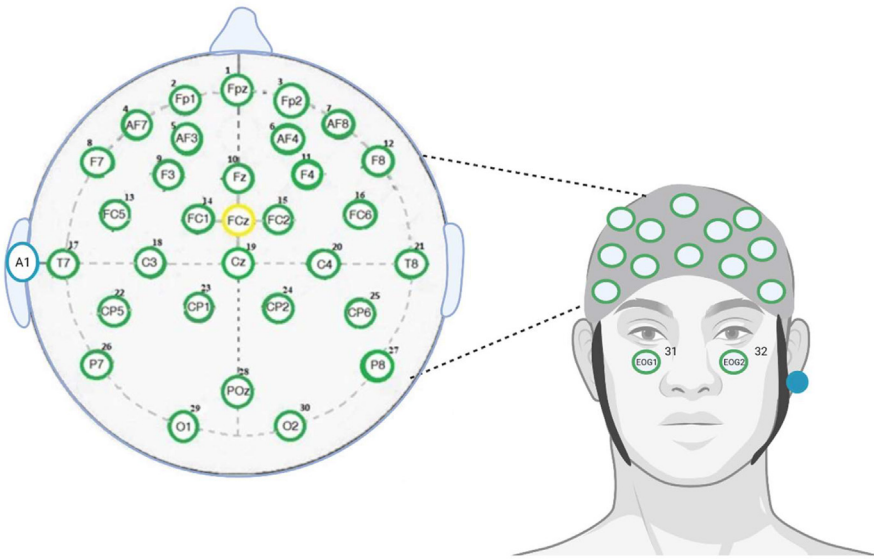

Fig. 2. Electrode distribution. Distribution of EEG and EOG channels, where channels 1–30 recorded EEG and channels 31–32 recorded EOG; this distribution was proposed for better processing of EEG signals, ensuring the elimination of EOG artifacts.

4.4. *g.USBamp EEG amplifier*

Two synchronized *g.USBamp* amplifiers were used to record 32 EEG channels, 16 DC-coupled wide-range input channels per unit. With a sampling frequency of 256 Hz, electrode-skin interface impedance is less than 5 k Ω . This bioamplifier has an input range of 250 mV, allowing direct current signals to be recorded without saturation. The FCz and A1 electrodes were the ground and reference electrodes of the system, respectively. Of the channels, 30 of them were for EEG, and 2 of them were for EOG recording. The positions of the electrodes that recorded EEG correspond to the standard sites of the international 10/20 system, and the location of the EOG electrodes is shown in Fig. 2.

4.5. *Tinnitus functional index (TFI)*

The TFI indicates the tinnitus affection on a scale of 1 to 100, where 25 or less than 25 indicates mild affection, 25–50 indicates moderate affection, and 50 or more indicates severe affection [10]. TFI was included in experimental procedure to measure the level of involvement in eight different fields: 1) intrusiveness, 2) sense of control, 3) cognitive interference, 4) sleep disturbance, 5) auditory difficulties, 6) relaxation interference, 7) reduction in quality of life, and 8) emotional distress.

4.6. *Hospital anxiety and depression scale (HADS)*

The HADS questionnaire has been widely used to assess emotional distress in patients with chronic conditions [11]. HADS was included in the experimental procedure to measure the emotional impairment of tinnitus sufferers related to their condition. This identification of anxiety and depressive disorders in tinnitus patients is important to attempt to disentangle the hetero-

genity of this symptom. HADS has been reported as a useful scale for screening in tinnitus patients [12].

4.7. Experimental procedure

An experimental procedure was implemented for each study group divided into two sessions. In the face of the COVID-19 pandemic, the participant and examiner's health and safety were considered. Therefore, direct contact time was minimized by implementing a virtual session to inform the participant about the procedure. Subsequently, with their consent, a face-to-face session was scheduled with the pertinent sanitary measures to acquire the study data. The sanitary measures were: 1) the use of face coverings for both the examiner and the participant, 2) the use of a mask for the examiner, 3) continuous disinfection of the work area, and (4) the use of antibacterial gel.

4.7.1. Tinnitus group (TG)

In the virtual session, the protocol and scientific purpose of data collection were informed, guaranteeing confidentiality. After obtaining the electronic informed consent, the TFI and HADS questionnaires (electronic format in Spanish) were applied. Finally, the face-to-face session was scheduled no later than one week later.

In the face-to-face session, subjective clinical characteristics were first acquired through a tonal audiometry (hearing level), and a tinnitus pitch matching (tone and intensity). Tinnitus sounds were generated according to the hearing thresholds. EEG signals were recorded in line with the following paradigm: 1) baseline condition, where the participant remained in a state of rest, with eyes open (2.53 min); and 2) active condition, where the participant had the task of identifying their sound tinnitus. A 5min-break was provided between conditions. In total, the face-to-face session lasted approximately 50 min.

4.7.2. Control group (CG)

The virtual session was to inform about the procedure, and the investigation purpose of the data collection, guaranteeing confidentiality. After their informed consent, a face-to-face session was scheduled.

In the face-to-face session, auditory thresholds were obtained through tonal audiometry (hearing level). The tinnitus sounds were generated by superimposing with a tone of 3.5 kHz (a tone they would have to identify during active condition). The experimental paradigm was as follows: 1) basal condition, where the person remained in a state of rest with eyes open; 2) active condition, where the participant had the task of identifying the 3.5 kHz sound stimulus, which they listened to for one minute before starting with the identification within the sound-tinnitus library. At the end of the session, they were thanked for participating in the protocol and for sharing the results of tonal audiometry.

4.8. Experimental paradigm

The experimental paradigm consisted of two stages: 1) passive, where the person remained in a state of rest with eyes open; 2) active, where the participant was tasked with identifying a specific sound stimulus (tinnitus for GA and 3.5 kHz tone for GC). The experimental paradigm was developed on the OpenViBE software platform. OpenViBE allows to design experimental paradigms, and store EEG records, among other functions [13].

Volunteers were seated on a chair with a back in a comfortable position, with the instruction to move as little as possible. A monitor was placed one meter away, where visual reinforcements were shown, and which guided the person during the paradigm. Additionally, auditory instructions were used before each scenario to guarantee the person performed the activity correctly.

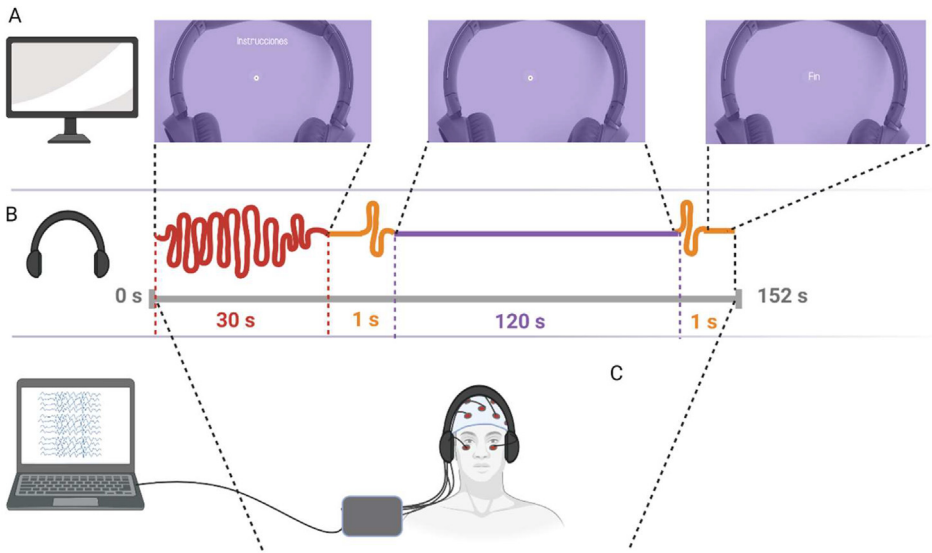

Fig. 3. Experimental paradigm at baseline: spontaneous EEG activity with eyes open for two minutes. At the beginning of the registration, auditory instructions (red) were administered through hearing aids (B), followed by a one-second beep sound (orange) to indicate to the participant both the start and end of the registration. During registration, a visual reinforcement (A) marked where the participant had to keep their gaze fixed.

4.8.1. Basal stage

The description of the events in the passive stage of the experimental paradigm is shown in Fig. 3. First, the auditory instructions instructed the participant to remain with their eyes open during registration. Visual reinforcements were used to keep the person gaze fixed at a point, as well as sound reinforcements to indicate the beginning and end of the two-minute record. This records the spontaneous activity of the participant.

4.8.2. Tinnitus sound identification (Active mode)

Two different experimental paradigms for active mode were implemented for both groups, TG and CG. Volunteers were recorded under the specifications shown in Fig. 4, but paradigms differed in the sounds and the activity to be performed. Each paradigm had 55 stimuli (54 sounds and one silence), lasting one second. The intensity was adjusted to the results of the tonal audiometry, increasing 10 dB [14] over their respective thresholds at each frequency, and the time between stimuli had a random value of three to five seconds. The sound stimulation step was randomly repeated three times, having three minutes of rest between them. The total time of the paradigm was 30 min. In addition, stimuli that the participant identified were marked with a label when pressing the button.

4.9. Pre-processing EEG signals

Once all EEG recordings were obtained, the signals were pre-processed to remove external and internal artifacts using EEGLab v2022.1, a MATLAB v2022b Toolbox that allows the processing of different electrophysiological signals [15].

To remove the artifacts, as shown in Fig. 5, first, the spherical coordinates of the channels were added, as well as the removal of the baseline. Channels EOG1 and EOG2 were referenced to the Fpz channel. The original bandwidth of the register from 0.1 to 100 Hz was maintained.

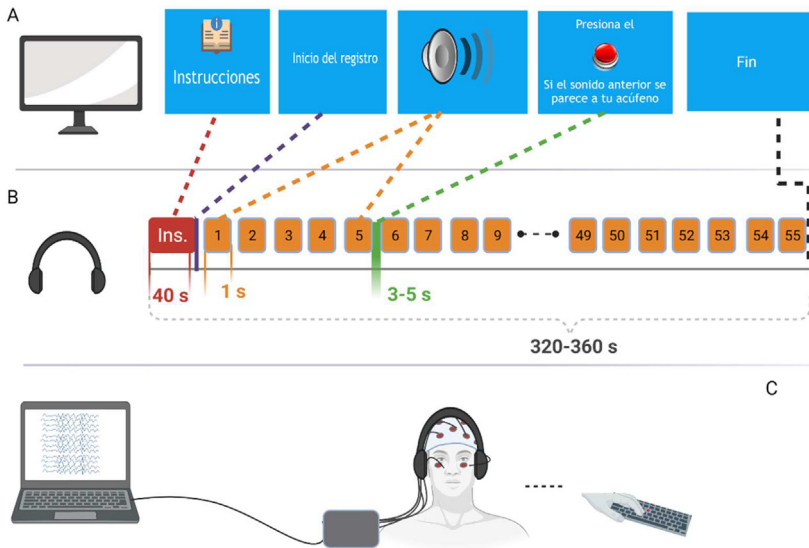

Fig. 4. Experimental paradigm active stimulation. At the beginning of the registration, the instructions (red) of the task were administered via the auditory (B). Subsequently, 55 sound stimuli were played, with an interstimulus space (green line) of three to five seconds. Each stimulus (orange) lasted one second. A mark was placed on the record when the participant identified a sound by pressing a button (C). Additionally, visual reinforcements (A) were used to maintain the participant's attention. In total, one stage lasted between five to six minutes.

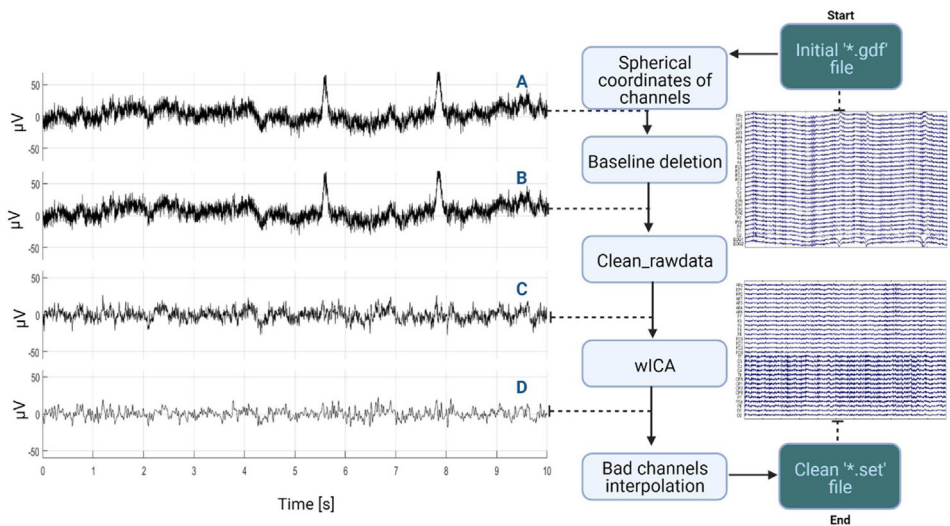

Fig. 5. Pre-processing of EEG recordings. (A) is a fragment of a person's original record of the Fz channel. It has internal artifacts (flickers). Then, the baseline (LB) is eliminated, resulting in (B). The removal of occasional artifacts with Clean_rawdata (C) was applied. The independent components were calculated, and the artifacts of each component were attenuated with wICA (D). Finally, the channels that were removed were interpolated, and the EEG channels were removed; the 30 artifact-free EEG channels were stored in '*.set' format.

Second, transient artifacts were removed through the EEGLab plugin Clean_rawdata v2.91, where from the 30 EEG channels, the channels that had the most artifacts were removed, i.e., flat line threshold – 5 s, noisy line threshold – 5 s, a low correlation with adjacent channels (correlation threshold – 0.8). In addition, segments of the record with amplitude artifacts were eliminated (information reconstruction was not applied).

Third, Independent Component Analysis (ICA) was applied that separates source signals as different Independent Components (ICs) [16]; the ICA *Infomax* version was used using the runic *EEGLAB algorithm*, as it has been reported to give stable decompositions. EEG and EOG channels were included. The EEG signal was filtered between 1 and 100 Hz to apply ICA. Once the algorithm calculated the IC weights, all IC weights from the filtered 1–100 Hz register were copied to the Clean_rawdata output file. Subsequently, this was used to eliminate the artifacts of each ICs. wICA v5.3 implements *wavelet thresholding* to attenuate those not corresponding to an EEG signal. It allows the recovery of neural activity in contaminated components [17]. Finally, all removed channels were interpolated using the EEGLAB `eeg_interp()` function with the *spherical interpolation method* [18]. This pipeline is available in <https://github.com/AlmaSTT/ChaTinnitusEEG>.

Limitations

The reference to measure the bias of the tinnitus characterization system was subjective tinnitus pitch matching. Measurements in this study often vary \pm an octave [19]. That is, if the person selected the frequency of 4 kHz during subjective tinnitus pitch matching; the confusion range could be from 2 kHz to 8 kHz. That is why bias is an auxiliary indicator for selecting methodologies. To have a more accurate reference, it will be necessary to establish a more precise reference in the future.

Ethics Statement

Before the start of the experiment, all patients provided written informed consent according to the World Association Declaration of Helsinki. This study was approved by the Clinical Investigation Ethics Committee of Tecnológico de Monterrey (number: P000369-DN-RespElectroCI-CR005).

CRedit author statement

Alma Socorro Torres-Torres: Literature Research, Conceptualization, Data Recording, Pre-processing Data, Writing – original draft & editing; **Luz María Alonso-Valerdi:** Supervision, Conceptualization, Writing – review & editing; **David I. Ibarra-Zarate:** Participant recruitment, Supervision – review; **Andrea González-Sánchez:** Writing – original draft.

Data Availability

[Characterization of Tinnitus Through the Analysis of Electroencephalographic Activity \(Original data\)](#) (Mendeley Data)

Acknowledgements

Funding for this project was provided to ASTT by Consejo Nacional de Ciencia y Tecnología (CONACYT) (Grant number: 1008912) and Tecnológico de Monterrey by granting a full tuition

scholarship to ASTT. All data acquisition equipment and supplies provided for data collection belong to the Neuroengineering and Neuroacoustics Research group from Tecnológico de Monterrey.

Declaration of Competing Interest

The authors declare that they have no known competing financial interests or personal relationships that could have appeared to influence the work reported in this paper.

References

- [1] J.P.T.M. Noordhuizen, K. Frankena, M.V. Thrusfield, E.A.M. Graat, Application of Quantitative Methods in Veterinary Epidemiology, 2001 second, revised reprint.
- [2] A. Piarulli, et al., Tinnitus and distress: an electroencephalography classification study, *Brain Commun.* 5 (1) (2023).
- [3] M.S. Mahmud, F. Ahmed, M. Yeasin, C. Alain, G.M. Bidelman, Multivariate models for decoding hearing impairment using EEG gamma-band power spectral density, in: Proceedings of International Joint Conference on Neural Networks, 2020.
- [4] J.S. Wimmer del, R.S. Donoso, A.C. Leiva, H.K. breinbauer, P.R. délano, Aceptado el 1 de Noviembre, 2018.
- [5] D.I. Ibarra Zarate, L.M. Alonso Valerdi, A.R. Cuevas Romero, L.A. Intriago Campos, Acoustic Therapies for Tinnitus Treatment: An EEG Database, 2022 vol. 2.
- [6] N. Weisz, S. Muller, W. Schlee, K. Dohrmann, T. Hartmann, T. Elbert, The neural code of auditory phantom perception, *J. Neurosci.* (2007).
- [7] E. Houdayer, et al., Involvement of cortico-subcortical circuits in normoacoustic chronic tinnitus: a source localization EEG study, *Clin. Neurophysiol.* (2015).
- [8] InteracousticsAD226 Audiómetro de Diagnóstico El Auténtico Audiómetro Híbrido Portátil, 2017.
- [9] "SRH440 - SRH440 Audífonos de calidad profesional." [Online]. Available: <https://www.shure.com/es-MX/productos/audifonos/srh440>. (Accessed 10 March 2021).
- [10] K. Fackrell, D.A. Hall, J.G. Barry, D.J. Hoare, Performance of the Tinnitus Functional Index as a diagnostic instrument in a UK clinical population, *Hear. Res.* 358 (Feb. 2018) 74–85.
- [11] M. Carmen Terol-Cantero, V. Cabrera-Perona, M. Martín-Aragón, Revisión de estudios de la Escala de Ansiedad y Depresión Hospitalaria (HAD) en muestras españolas1 macarmen@umh.es, *An. Psicol.* 31 (2) (2015) 494–503.
- [12] S. Zöger, J. Svedlund, K.M. Holgers, The Hospital Anxiety and Depression Scale (HAD) as a screening instrument in tinnitus evaluation, *Int. J. Audiol.* 43 (8) (2004) 458–464.
- [13] "OpenViBE | Software for Brain Computer Interfaces and Real Time Neurosciences." [Online]. Available: <http://openvibe.inria.fr/>. (Accessed 10 March 2021).
- [14] C.-É.C. Basile, P. Fournier, S. Hutchins, S. Hébert, Psychoacoustic Assessment to Improve Tinnitus Diagnosis, *PLoS ONE* 8 (12) (2013) 82995.
- [15] "6. Reject artifacts - EEGLAB Wiki." [Online]. Available: https://eeglab.org/tutorials/06_RejectArtifacts/. (Accessed 11 March 2021).
- [16] S.K. Noorbasha, G.F. Sudha, Removal of EOG artifacts and separation of different cerebral activity components from single channel EEG—an efficient approach combining SSA–ICA with wavelet thresholding for BCI applications, *Biomed. Signal Process. Control* 63 (2021) 102168.
- [17] N.P. Castellanos, V.A. Makarov, Recovering EEG brain signals: artifact suppression with wavelet enhanced independent component analysis, *J. Neurosci. Methods* 158 (2) (2006) 300–312.
- [18] A. Pedroni, A. Bahreini, N. Langer, Automagic: standardized preprocessing of big EEG data, *Neuroimage* 200 (2019) 460–473.
- [19] H.F. Haider, T. Bojić, S.F. Ribeiro, J. Paço, D.A. Hall, A.J. Szczepek, Pathophysiology of subjective tinnitus: triggers and maintenance, *Front. Neurosci.* (2018).