



## Durham E-Theses

---

# *An Optimality Theory Account of the Non-concatenative Morphology of the Nominal System of Libyan Arabic, with Special Reference to the Broken Plural*

GABER, GABER,MEFTAH

### How to cite:

---

GABER, GABER,MEFTAH (2012) *An Optimality Theory Account of the Non-concatenative Morphology of the Nominal System of Libyan Arabic, with Special Reference to the Broken Plural*, Durham theses, Durham University. Available at Durham E-Theses Online: <http://etheses.dur.ac.uk/3511/>

### Use policy

---

The full-text may be used and/or reproduced, and given to third parties in any format or medium, without prior permission or charge, for personal research or study, educational, or not-for-profit purposes provided that:

- a full bibliographic reference is made to the original source
- a [link](#) is made to the metadata record in Durham E-Theses
- the full-text is not changed in any way

The full-text must not be sold in any format or medium without the formal permission of the copyright holders.

Please consult the [full Durham E-Theses policy](#) for further details.

---

Academic Support Office, Durham University, University Office, Old Elvet, Durham DH1 3HP  
e-mail: [e-theses.admin@dur.ac.uk](mailto:e-theses.admin@dur.ac.uk) Tel: +44 0191 334 6107  
<http://etheses.dur.ac.uk>

**An Optimality Theory Account of the Non-concatenative  
Morphology of the Nominal System of Libyan Arabic, with  
Special Reference to the Broken Plural.**

**A Thesis Submitted to the University of Durham  
For the degree of**

**DOCTOR OF PHILOSOPHY**

By

**GABER MEFTAH GABER**

University of Durham  
School of Modern Languages and Cultures  
Arabic Department  
2012

## Abstract

### An Optimality Theory Account of the Non-concatenative Morphology of the Nominal System of Libyan Arabic, with Special Reference to the Broken Plural.

This work presents a full and unified investigation of the phenomenon of non-concatenative nominal morphology in Libyan Arabic (LA), with special reference to the formation of the broken plural (BP). The analysis provides a morphophonological account of morphologically derived words in LA. It is based on two main ideas: the first is specifying the input for the derivational morphological process which represents the underlying structure of the derived word; the second is to account for the phonological constraints which interact with each other on the underlying structure in order to determine the optimal output for the derived word.

In contrast to previous studies which fail to recognize derivational morphological processes and consequently cannot identify the nature of the input of the derived word, this thesis identifies the input as the starting point to justify the resulting derived output.

This thesis argues that the nature of the input in non-concatenative morphology must be accounted for first. The morphological process starts when elements of the input which are carried over to the output are identified, and the specified derivational morphemes are supplied. These together form the underlying structure of any derived word. The underlying structure of the derived word in this thesis is considered to be the string of root consonants and any morphological component associated with the input, plus the derivational morphemes of the intended morphological process. As a consequence of identifying the nature of the input, the template which has been associated with Arabic language, is revealed in this thesis that it is not a primitive but rather it is an artefact of the phonology operating on morphological products. Thus, phonology has no role in the underlying structure, but comes into play to repair any ill-formed surfaced structure. The types of constraints which operate on the outputs are phonological constraints concerning markedness and faithfulness constraints. The function of markedness constraints is to maintain the well-formedness of the output,

while the function of faithfulness constraints is to preserve the morphological identity of the components of the underlying structure.

## **Acknowledgments**

First of all, all praise is to Allah (God) for assisting me to carry out this research. Secondly, I am very grateful to my academic advisor, Professor Daniel Newman, for his fine supervision as well as his continuous help and advice without which this work would almost certainly not have come into existence.

My thanks are also to Dr Salvindra Jayraj for his inspiring ideas and enlightening discussions which I had with him before the course of the study which helped me immensely in making this work to become a reality.

A special gratitude goes to the University of Sirt for nominating me, and also to the Libyan Ministry of Higher Education for sponsoring me to do a PhD in the UK.

I would also like to extend my warm thanks to my beloved family, especially my wife and my three children who have always supported me emotionally and who have been the candles that lit my way into the darkness.

## **Dedication**

*To my father and mother  
To my brothers and sisters  
To my wife and children  
To every member of my extended family*

## **Declaration**

I hereby declare that this thesis is an original piece of work of mine. No part of this thesis has been previously published or submitted for another award or qualification in other institutions or universities.

## **Statement of Copyright**

Any information derived from this thesis should be acknowledged appropriately.



# Table of Contents

<b>Abstract</b>	
<b>List of Abbreviations and Symbols</b>	vii
<b>Chapter 1 : Introduction</b>	1
1.1 Preliminaries	1
1.2 Libyan Arabic	2
1.3 Research Questions	3
1.4 Research Hypothesis	4
1.5 Aims of the Thesis	4
1.6 Sources of Data	5
1.7 Data Analysis	6
1.8 Outline of the Thesis	7
<b>Chapter 2 : Previous studies of the non-concatenative Arabic Broken Plural</b>	8
2.1 Classical Arabic Account of BP	9
2.1.1 Meanings Associated with some Templatic BP Adjectives	12
2.1.1.1 Form /C <sub>1</sub> uC <sub>2</sub> C <sub>2</sub> a:C <sub>3</sub> /	12
2.1.1.2 Form /CaCaC-at/	13
2.1.1.3 Form /CuCCaC/	14
2.1.1.4 Form /CaCa:CiC/	14
2.1.1.5 Form /CuCCa:n/	15
2.1.1.6 Form /CaCCa:/ and /CaCa:Ca:/	15
2.1.1.7 Form /CuCaCa:ʔ/ and /CiCa:C/	15
2.1.1.8 Form /CaCa:ʔiC/	16
2.2 Derivational Morphology	16
2.2.1 Derivational Major Plural Rules	17
2.2.2 Derivational Minor Plural Rules	18
2.3 SP and BP Lexical Features Assignment	20
2.4 Templatic Morphology	34
2.5 Active Derivational Morphological Sites	37

2.5.1	Root-and-Site Hypothesis	38
2.5.1.1	The Formation of Irregular BPs	49
2.5.1.2	The Formation of SPs	50
2.5.2	Roots and Sites	51
2.5.2.1	Nominal Formation in the Root and Sites Approach	52
2.5.2.1.1	The Nominal Morphology of CA	52
2.5.2.1.2	The Formation of BP from a Root and Site perspective	54
2.5.2.1.3	The Formation of BP based on Root and Site	56
2.6	Prosodic Circumscription	62
2.6.1	Positive Prosodic Circumscription	62
2.6.2	Negative Prosodic Circumscription	66
2.7	Faithfulness and Prosodic Circumscription	71
2.7.1	Prosodic Faithfulness	71
2.7.2	Prosodic Circumscription as Moraic Faithfulness	72
2.8	Gaps in Previous Studies of BP	76
2.9	Conclusion	82
<b>Chapter 3 : An Optimality Theory Account of Non-concatenative Morphology</b>		<b>83</b>
3.1	Introduction to Optimality Theory	83
3.2	Correspondence in Optimality Theory	86
3.2.1	Standard Correspondence Theory	87
3.2.2	Transderivational Output-Output (O-O) Correspondence	87
3.2.3	Output-Output Correspondence Based on LA Plural Formation	89
3.3	The Input for Non-concatenative Morphology	96
3.4	Lexicon Optimization from Non-concatenative Morphological Perspective	102
3.5	Conclusion	106
<b>Chapter 4 : The Prosodic Structure of Libyan Arabic</b>		<b>108</b>
4.1	Introduction	108
4.2	Previous Accounts of CA Syllable Structure	115
4.2.1	An Autosegmental Account of the Syllable	115
4.2.2	A Moraic Account of the Syllable	125
4.2.3	Syllable Structure in OT	127
4.3	Syllable Structure and Syllabification in LA	129
4.3.1	Syllable Patterns in LA	129
4.3.2	Syllable Structure and Syllabification in LA	131

4.3.3	Semisyllables in LA	135
4.4	Phonotactics of LA	137
4.4.1	Consonant Clusters	137
4.4.1.1	Initial Position	138
4.4.1.2	Across the Morpheme Boundary	139
4.4.1.3	Medial Position	140
4.4.1.4	Final Position	140
4.4.2	Glides Distribution	141
4.4.3	Vowel and Consonant Lengthening	152
4.4.4	Geminates	155
4.4.4.1	Initial Consonant Doubling	155
4.4.4.2	Medial Consonant Doubling	156
4.5	The Prosodic Word in LA	158
4.6	Stress Assignment in LA	163
4.7	Conclusion	168
<b>Chapter 5 : Non-concatenative Derived Nouns in LA</b>		169
5.1	Introduction	169
5.2	Nouns	171
5.2.1	Moraic Structure of Nouns	171
5.2.1.1	Triliteral Nouns with Two Moras	172
5.2.1.2	Triliteral Nouns with Three Moras	172
5.2.1.3	Triliteral Nouns with Four Moras	173
5.2.1.4	Quadriliteral Underived Nouns with Three Moras	174
5.2.1.5	Quadriliteral Underived Nouns with Four Moras	174
5.3	Derivation of Nouns	174
5.3.1	Verbal Nouns	175
5.3.1.1	Triliteral Root VN	176
5.3.1.1.1	Form I	176
5.3.1.1.1.1	Short Vowel Morphemes	176
5.3.1.1.1.2	Long Vowel Morphemes	180
5.3.1.1.1.3	Long Vowels Plus Suffixational or Prefixational Morphemes	184
5.3.1.1.1.4	Suffixational Morphemes	188
5.3.1.1.2	Form II	189

5.3.1.1.3	Form III	192
5.3.1.1.4	Form IV	194
5.3.1.1.5	Form V	196
5.3.1.1.6	Form VI	197
5.3.1.1.7	Form VII	197
5.3.1.1.8	Form VIII	199
5.3.1.1.9	Form IX	200
5.3.1.1.10	Form X	200
5.3.1.2	Quadriliteral VN	202
5.4	Instance Nouns	204
5.5	Unit Nouns	205
5.6	Feminine Nouns	206
5.7	Locative Nouns	207
5.8	Instrumental Nouns	208
5.9	Occupational Nouns	209
5.10	Diminutive Nouns	209
5.11	Inflection	210
5.12	Conclusion	214
<b>Chapter 6 : Non-concatenative Derived Adjectives in LA</b>		215
6.1	Adjectives Derived from Triliteral Roots	215
6.2	Participles	220
6.2.1	Triliteral Adjectives	221
6.2.1.1	Form I	221
6.2.1.2	Form II	228
6.2.1.3	Form III	230
6.2.1.4	Form IV	231
6.2.1.5	Form V	234
6.2.1.6	Form VI	236
6.2.1.7	Form VII	237
6.2.1.8	Form VIII	240
6.2.1.9	Form IX	242
6.2.1.10	Form X	242
6.2.2	Quadriliteral Adjectives	245
6.3	Inflection	246

6.3.1	Gender	246
6.3.2	Number	247
6.3.2.1	Sound Plural	247
6.4	Conclusion	250
<b>Chapter 7 : Non-concatenative Derived Broken Plurals in LA</b>		251
7.1	Introduction	251
7.2	Bilateral Roots	252
7.3	Trilateral Root Consonants	255
7.3.1	Form /C <sub>4</sub> uC <sub>1</sub> C <sub>2</sub> u : C <sub>3</sub> /	255
7.3.2	Form /C <sub>4</sub> iC <sub>1</sub> C <sub>2</sub> a : C <sub>3</sub> /	259
7.3.3	Form /C <sub>1</sub> vC <sub>2</sub> C <sub>3</sub> a : C <sub>4</sub> /	264
7.3.4	Form /C <sub>1</sub> iC <sub>2</sub> C <sub>2</sub> a : C <sub>3</sub> /	267
7.3.5	Form /C <sub>1</sub> aC <sub>4</sub> a : C <sub>2</sub> iC <sub>3</sub> /	270
7.3.6	Form /C <sub>1</sub> uC <sub>2</sub> aC <sub>3</sub> a : C <sub>4</sub> /	274
7.3.7	Form /C <sub>4</sub> aC <sub>1</sub> C <sub>2</sub> iC <sub>3</sub> a : C <sub>5</sub> /	276
7.3.8	Form /C <sub>1</sub> aC <sub>2</sub> a : C <sub>4</sub> iC <sub>3</sub> /	277
7.3.9	Form /C <sub>1</sub> aC <sub>2</sub> a : C <sub>3</sub> i : /	282
7.3.10	Form /C <sub>1</sub> aC <sub>4</sub> a : C <sub>3</sub> a : /	284
7.3.11	Form /C <sub>1</sub> aC <sub>2</sub> C <sub>3</sub> a : /	287
7.3.12	Form /C <sub>1</sub> aC <sub>4</sub> a : C <sub>2</sub> i : C <sub>3</sub> /	288
7.3.13	Form /C <sub>1</sub> vC <sub>2</sub> vC <sub>3</sub> /	290
7.3.14	Form /C <sub>1</sub> uC <sub>2</sub> C <sub>3</sub> / ⇒ /C <sub>1</sub> uC <sub>2</sub> uC <sub>3</sub> /	293
7.4	Quadrilateral Root Consonants	296
7.4.1	Form /C <sub>1</sub> aC <sub>2</sub> a : C <sub>3</sub> i : C <sub>4</sub> /	296
7.4.2	Form /C <sub>1</sub> aC <sub>2</sub> a : C <sub>3</sub> C <sub>4</sub> -aʔ/	301
7.4.3	Form /C <sub>1</sub> aC <sub>2</sub> a : C <sub>3</sub> iC <sub>4</sub> /	303
7.5	Quinqueliteral Root Consonants	305
7.5.1	Form /C <sub>1</sub> aC <sub>2</sub> a : C <sub>3</sub> iC <sub>4</sub> /	305
7.6	Foreign Loanwords in LA	307
7.7	Multiple BP Candidates	314
7.8	Plural of the Plural	321
7.9	Morpho-syntactic and Morpho-semantic Constraints on Qualifying for BP	322
7.10	Overveiw of Constraints Interaction and Ranking	328

7.11	Conclusion	331
<b>Chapter 8 : Summary and Conclusions</b>		<b>333</b>
-	References	
-	Appendix: List of OT Constraints	

## List of Abbreviations and Symbols

^	This diacritic marks any derivational morpheme
X	Refers to any segment
Σ	Stem
⇒	Direction of derivation
!	Fatal violation
*	Asterisk shows a constraint violation
√	Root
μ	Mora
acc.	Accusative
Adj	Adjective
AH	Avoid harmony
AP	Active participle
BP	Broken plural
C	Root consonant (usually subscripted number showing a sequence order)
CA	Classical Arabic
CLRs	Concrete lexical representations
CON	Constraint
EVAL	Evaluator
F	Feature
Fem.	Feminine
Fqu	Quantitative trochaic foot
FSP	Feminine sound plural
FT	Foot
G	Glide
gen.	Genitive
GEN	Generator
HPSG	Head-driven phrase structure grammar
IO	Input-output
LA	Libyan Arabic
Masc.	Masculine
MORPH.	Morpheme
MSA	Modern Standard Arabic
MSP	Masculine sound plural
N	Noun
NCC	Number of consonants constraint
NIS	Nominal inflection site
Nom.	Nominative
NPC	Negative prosodic circumscription
Nuc	Nucleus
NUM.	Number
O	Onset
OCP	Obligatory contour principle
O-O	Output-output correspondence
OT	Optimality theory
Pl.	Plural
Pl./Pl.	Plural of the plural

Pl./Pl./Pl.	Plural of the plural of the plural
PPC	Positive prosodic circumscription
PRWD	Prosodic word
QL	Quadriliteral (root consonant)
QqL	Quinqueliteral (root consonant)
R	Root
Ry	Rhyme
sb.	Somebody
SD	Sirt dialect
Sing.	Singular
SP	Sound plural
TD	Tripoli dialect
TL	Triliteral (root consonant)
W	Word
V	Vowel
VDS	Verbal derivation site
VIS	Verbal inflectional site
VN	Verbal noun
VOC.	Vocalic





## **Chapter 1: Introduction**

### **1.1 Preliminaries**

In derivational morphology, there are two kinds of morphology, which suggests affixation, reduplication, etc., which are distinguished in many languages. These are concatenative and non-concatenative morphology, and Libyan Arabic (LA) exhibits both. Non-concatenative derivational morphology is the most productive in generating new lexical words. In Arabic in general and in LA in specific, the derivational morphology of non-concatenative nominal system has not, however, been studied in the light of an analytical linguistic theory from a morphological perspective. One of the phenomena of non-concatenative morphology which has received some attention in Classical Arabic (CA) and Modern Standard Arabic (MSA) is pluralization. Under pluralization, the broken plural (BP) is one of the most-debated issues in Arabic linguistics. Although Arab grammarians have described BP, it has been re-examined in the light of modern linguistic theory. The derivation of BP is still a complicated issue in Arabic linguistics. Goweder et. al. (2004) stated that even in language engineering applications the retrieval of BP is a problematic issue since its derivation is linguistically so complicated. In an attempt at the linguistic description of BP, Wright (2005) established thirty-one patterns of lexical Arabic grammar among all possible patterns. He mentioned that roots in Arabic are marked lexically with their respective plural patterns.

In this thesis, the phenomenon of non-concatenative BP is taken as the starting point to explore it and other similar morphological processes within the nominal system of LA. In fact, both the verb system and the nominal system productively exhibit many non-concatenative processes. However, the main focus here is restricted to the nominal system, and there is a similar paucity of research that investigates the

derivational non-concatenative morphological processes of this nominal system in order to make generalisations. To compensate for such a lack, previous studies that dealt with BP are investigated and their linguistic approaches are evaluated in order to understand the derivational morphological processes in BP formation. Then, by identifying the actual morphological processes of BP derivation, these processes will be extended to account for other non-concatenative processes in the noun and adjective systems.

## **1.2 Libyan Arabic**

Libya is a Muslim country and the majority of the population are Arabs. The remaining ethnic minorities include Berbers, Tuaregs, and Tebus. The official language of the country is Arabic. Libya is located in the north of Africa, lying on the Mediterranean Sea with a coastline of roughly 1900 kilometres. It has an area of 1.76 million square kilometres, most of which is desert. This huge area of land is populated by around 6 million people, most of whom live along the coastline in the western area and specifically in and around the capital, Tripoli. Around one-fifth of the population live along the coastline in the eastern coastal area, most of whom live in Benghazi, the second largest city. The distance between Tripoli and Benghazi is 1000 kilometres. Sirt, whose inhabitants represent the language under investigation, lies nearly halfway between the two biggest cities. Sirt is the capital of the Sirt district with a population of around 160000, nearly 100000 of whom live in Sirt city.

LA is, in fact, a collective term used to refer to the closely related dialects spoken in Libya. In general terms, LA speakers have two languages for communication. Speakers have a spoken language (dialect), known as ‘ǧa:mmijah’ or ‘lahǧah’, and a formal language (CA, or as its modern version is nowadays identified, MSA), known as ‘fus<sup>h</sup>ah’. There are no huge structural differences between CA and MSA (Ryding, 2005). The main difference could be related to richness of the lexicon of MSA. Thus, this thesis does not differentiate between the two languages since their morphological and phonological processes are similar. The dialect is natively acquired at home and used in everyday informal communication. It is also used in the folklore and the cultural activities such as poetry, storytelling, and informal

conversations. On the other hand, CA is accepted as the formal language not only in Libya but in all Arab countries. CA is learned as a spoken and written language as early as the first year of school. The use of CA is widespread, especially in the Quran and religious teachings, newspapers, radio, and television.

Although there are many similarities between the grammar of the dialect and CA, their differences make the dialect ambiguous when it is expressed in a written CA text. Such differences come from different grammatical areas, such as the corresponding phonetic representations of many segments, the phonological realizations of some segments, and the morphophonological interaction in morphological derivational processes. Also, the dialect omits case endings from nouns and adjectives, lacks mood distinctions in verbs, and lacks dual number markers. Consequently, research into the dialect has been always limited, since many researchers have investigated the language in the light of CA because the latter is considered optimal. Regardless of compatibility with the written or the spoken language of CA, LA still shares many characteristics with it. In fact, as LA is historically related to CA, the morphology of CA can be considered as the input for all the words in LA which have an Arabic origin. In derivational morphology, for instance, the difference between derived words in CA in comparison with the same corresponding derived words in LA can almost always be attributed to the preference of phonological constraints.

### **1.3 Research Questions**

The thesis is a morphophonological study of the non-concatenative morphological processes of LA (the Sirt Dialect, SD) nominal system of nouns and adjectives with special reference to the formation of BP. It attempts to explore the following main research question: ‘What are the components of the input for the non-concatenative morphological processes of nouns, adjectives, and BP systems?’ The importance of this question is to reveal the actual elements of the input which contribute to the derivational morphological process. Based on the main research question, there are two sub-related questions to be investigated. The first is ‘How can the input of the derivational process be computed in an OT framework in order to justify the relations

of correspondence between the input and the multiple corresponding candidates of the derived output words?’ The second is ‘What are the active morphophonological constraints which interact to modify the optimal output derived candidate?’

#### **1.4 Research Hypothesis**

The key research hypothesis of this thesis is stated as follows; ‘The optimal non-concatenative derived output word is better understood by identifying the morphological process and the related morphophonological constraints that properly form that derived output word’.

To justify the well-formedness of the derived output word in non-concatenative morphological processes, there are two correspondence relations that must be established. The first is input-output correspondence relations which can account for any materials carried over from the input to the output, whether morphological or phonological. The second is to account for the materials that are added to the output and do not exist in the input. By identifying such correspondence relations, the morphological processes and the active phonological constraints can be identified. In addition, such correspondence relations should allow the borderline to be drawn between morphological and phonological processes in the derivational processes of non-concatenative morphology.

#### **1.5 Aims of the Thesis**

The first aim of the thesis is to give an extensive and intensive account of the non-concatenative morphology of nouns and adjectives, with a focus on the BP. This cannot be achieved unless the input for the derivational morphological process is identified. Thus, the other aim is to identify the nature of the input for any derived nominal form. Since this study adopts the framework of OT, specifying the input is vital in order to justify the well-formed structure of the derived word. Another aim is to account for the morphophonological constraints which interact to determine the optimal candidate output derived word. The other aim is to distinguish between the morphological and the phonological processes of the non-concatenative nominal

system. Therefore, the starting point in understanding the non-concatenative or even concatenative morphology of the language is, as is demonstrated throughout this thesis, the exact identification of the nature of the input.

To the present researcher's best knowledge, SD has not been investigated in the light of a linguistic theory. Hence, the other aim of this thesis is to provide a linguistic account for the morphological processes discussed and the morphophonological interaction between the products resulting from the morphological processes and the active phonological constraints that shape those products when they surface as outputs. More specifically, the thesis is largely devoted to accounting the linguistic behaviour of the input in non-concatenative morphology with independent but interrelated chapters devoted to the noun, adjective, and the formation of BP.

## **1.6 Sources of Data**

Most of the work on the nominal system of Arabic, including BP, is based largely on the grammatical work by Sibawayh (760-796 AC) (1999), Ibn Aqil (1040-1119 AC) (2005), and Wright (2005). The morphological processes associated with the concatenative and non-concatenative morphology of CA is similar to those exist in LA. At the morphological level, the derivational morphemes are almost identical. However, at the phonological level there are some structural preferences favoured or disfavoured by LA, especially in syllabification.

The Arabic sources mentioned above serve as the starting point. The patterns or forms found in Arabic are crosschecked with those of LA, as accounted for by Elfitoury (1976) and Elgadi (1986) for the Tripoli dialect, Harrama (1993) for the *al-Jabal al-Garbi* dialect (the western mountain dialect), Abdunnabi (2000) for *al-Jabal al-Akhdhar* dialect (the green mountain dialect, which is one of the varieties of eastern Libyan dialects), and Owens (1984) for some eastern Libyan dialects spoken in and around Benghazi. And for SD, we crosscheck with a few sources of (Al-Zoaby et.al, 2005; Mohammed et. al., 2006. Being a native speaker of Arabic as well as of SD, many facts of the dialect in this thesis are the researcher's own native speaker judgements.

Unless clearly specified, the term LA in its general sense refers throughout this thesis to the dialects spoken in Libya. However, the specific use of this term here refers to the dialect spoken within and around the Sirt area. This is because the linguistic characteristics and features of the dialect spoken in Sirt have not been investigated thoroughly in such a way that the dialect/s could be distinguished from other dialects. Another reason is, as put forward by Owens (1984), that the area of Sirt is considered as a transitional dialect.

## **1.7 Data Analysis**

The data is analyzed in the light of Correspondence Theory (McCarthy and Prince, 1995; Benua, 1997, 2004). All the segments of the input, whether the source of derivation is a verb or nominal or other form, stand in a correspondence relation with all the segments of the output derived word. In such one-to-one correspondence relations, the relations of faithfulness between the input and the output will never be fully satisfied. This is simply because the morphological process of the input is different from that of the output, and moreover the phonological elements of the input are not preserved in the output derived word. The nominal system of LA shows that what actually remain in correspondence are the root consonants and sometimes some morphological elements of the input. Since the goal is to provide a linguistic account of the derived word, it is crucial to give a description of the components of its morphological process of the derived word. Throughout this thesis, examination of the nominal system of LA shows that the morphological process of the derived word consists of a string of root consonants, as well as, some morphological elements of the input, plus the derivational morphemes of the intended morphological process. These components represent the underlying structure of the derived word. The underlying structure becomes the input for the derivational process for the relevant derived word. At the surface level, the generator creates possible candidates and among them is the faithful underlying form. There is no way, however, for the underlying structure to surface as an optimal candidate since it is usually ill-formed with respect to the surface phonology. The malformation of the underlying structure is related to the fact that phonological processes only take place at the surface level. Investigating the non-concatenative morphology of LA provides solid evidence that all the phonological

constraints are active at the surface level, which is one of the principles of OT, in order to properly structure any ill-formed structure created by the morphological processes. This explains precisely why the phonological components of the input do not retain faithfulness correspondence relations with those of the output. Thus, any possible candidate must be checked in accordance with the active phonological and morphological constraints, and the optimal candidate must satisfy all the relevant top-ranked constraints in order to outrank the other competing candidates.

## **1.8 Outline of the Thesis**

In chapter two, a review of the core approaches that investigate BP is presented. Chapter three is dedicated to introducing OT. In this chapter, an extensive account of the consequences of correspondence theory in derivational morphology are presented and discussed on the light of the derivational processes of the non-concatenative nominal system. The state of the input in the derivational process of non-concatenative morphology is also discussed and justified. The phonological components related to the formation of non-concatenative morphology in LA are presented and explained in chapter four. In chapter five, the non-concatenative derivation processes related to noun are presented. The derivation of the adjective is accounted for in chapter six. Chapters five and six both support chapter seven, which is dedicated to the derivation of BP. Finally, some concluding remarks and suggestions for further study are presented in chapter eight.



## **Chapter 2: Previous studies of the non-concatenative Arabic Broken Plural**

This chapter discusses the core studies which have dealt with the morphological and phonological structure of BP. In this account, these studies are represented in parallel with the developments in linguistics in understanding the formation of BP. This parallel also partly reflects historical development since these studies could be assumed to follow a path corresponding to the development of linguistics. Thus, the review starts from descriptive accounts by CA grammarians, followed by transformational derivational studies, then templatic studies, and finally studies which adopt OT. The aim of this chapter is to lay out how previous studies have conceived of the mechanism of BP formation as well as their findings. By doing so, our aim is also to investigate the nature of the input in the BP derivational process and how the previous studies justified the relationship between the BP outputs to their singular inputs. Section 2.8 accounts for the gaps in previous studies and challenges them in the light of contemporary understandings of the underlying structure of the derived BP form which represents the input for BP derivation.

The idea of the underlying structure as the main input for derived non-concatenative morphological words is extended not only to account for BP formation, but is also generalized to account for the non-concatenative nominal system of LA, see section 3.3 for further details. Although this chapter is dedicated to various previous accounts of BP, it should be noted that we explicitly consider BP formation in terms of non-concatenative morphological processes. This has two advantages: the first is to account for the other non-concatenative processes of the nominal system, which have not been investigated previously; and the second is to account for the input in the nominal system of LA based on the nature of the underlying structure.

## 2.1 Classical Arabic Account of BP

In the literature of the CA nominal system, one may distinguish two kinds of plurals; that is, the sound plural (SP) and the BP. SP is divided into two kinds based on gender specification: masculine sound plural (MSP) is restricted to nouns and adjectives that refer mostly to male human beings and their identity or mixed groups of male and female human beings; and the feminine sound plural (FSP) is unrestricted and is used to refer to both feminine humans and nonhumans. The morphology of SP is of a concatenative type which involves suffixations to the stem word. The suffix for case marking of the MSP is /u:n/ in the nominative or /i:n/ in the genitive and the accusative. And the suffix for FSP is /a:t/ for all cases. The other type of plural is the BP, which is of the non-concatenative type. BP involves infixational material within the stem in such a way that the stem is totally restructured. The term ‘broken plural’ used by Arabic grammarians refers to the morphological process of this type of plural formation. This term means breaking the word into pieces in order to insert the BP morphemes. BP is further divided into two types: plural of paucity and plural of multiplicity. The plural of paucity is used only for persons and things which do not exceed ten in number (Wright, 2005, Vol. I, 234), whereas the plural of multiplicity is used to refer to more than ten. However, the latter is often used to refer to both kinds of BP. CA grammarians have accounted for four patterns of plurals of paucity: /ʔaCCiC-at/, /ʔaCCa:C/, /ʔaCCaC/, and /CiCC-at/. These patterns are given below accompanied by their corresponding BP forms. Some nominal forms have only a plural of paucity to mark the plural:

(1)

1. /C<sub>4</sub>aC<sub>1</sub>C<sub>2</sub>iC<sub>3</sub>at/

Singular Form	Plural of Paucity	BP
/f <sub>1</sub> ar <sub>2</sub> x <sub>3</sub> /, ‘chick’	/ʔ <sub>4</sub> af <sub>1</sub> r <sub>2</sub> i <sub>3</sub> at/	/f <sub>1</sub> ir <sub>2</sub> a:x <sub>3</sub> /
/z <sub>1</sub> ir <sub>2</sub> r <sub>3</sub> /, ‘button’	/ʔ <sub>4</sub> az <sub>1</sub> ir <sub>2</sub> r <sub>3</sub> at/	/z <sub>1</sub> ir <sub>2</sub> a:r <sub>3</sub> /

2. /C<sub>4</sub>aC<sub>1</sub>C<sub>2</sub>a:C<sub>3</sub>/

/s <sup>ʕ</sup> <sub>1</sub> aw <sub>2</sub> t <sub>3</sub> /, ‘sound/voice’	/ʔ <sub>4</sub> as <sup>ʕ</sup> <sub>1</sub> w <sub>2</sub> a:t <sub>3</sub> /	-
/ħ <sub>1</sub> uk <sub>2</sub> m <sub>3</sub> /, ‘judgment’	/ʔ <sub>4</sub> aħ <sub>1</sub> k <sub>2</sub> a:m <sub>3</sub> /	-

3. /C<sub>4</sub>aC<sub>1</sub>C<sub>2</sub>uC<sub>3</sub>/

/k <sub>1</sub> a <sub>2</sub> l <sub>3</sub> b <sub>3</sub> /, ‘dog’	/ʔ <sub>4</sub> a <sub>1</sub> l <sub>2</sub> u <sub>3</sub> b <sub>3</sub> /	/k <sub>1</sub> i <sub>2</sub> l <sub>3</sub> a <sub>3</sub> :b <sub>3</sub> /
/d <sup>ʕ</sup> <sub>1</sub> i <sub>2</sub> l <sub>3</sub> ʔ <sub>3</sub> /, ‘rib’	/ʔ <sub>4</sub> a <sup>ʕ</sup> <sub>1</sub> l <sub>2</sub> u <sub>3</sub> ʔ <sub>3</sub> /	/d <sup>ʕ</sup> <sub>1</sub> u <sub>2</sub> l <sub>3</sub> a <sub>3</sub> :ʔ <sub>3</sub> /

4. /C<sub>1</sub>iC<sub>2</sub>C<sub>3</sub>-at/

/ʃ <sub>1</sub> a <sub>2</sub> j <sub>3</sub> x <sub>3</sub> /, ‘old man’	/ʃ <sub>1</sub> i <sub>2</sub> x <sub>3</sub> -at/	/ʃ <sub>1</sub> i <sub>2</sub> j <sub>3</sub> a <sub>3</sub> :x <sub>3</sub> /
/ʔ <sub>1</sub> u <sub>2</sub> l <sub>3</sub> a <sub>3</sub> :m <sub>3</sub> /, ‘youth/slave’	/ʔ <sub>1</sub> i <sub>2</sub> l <sub>3</sub> m <sub>3</sub> -at/	/ʔ <sub>1</sub> i <sub>2</sub> l <sub>3</sub> a <sub>3</sub> :n <sub>4</sub> /

The plural of multiplicity has various forms and there are more than thirty productive patterns (Sibawayh, 1999, Vol. IV, 47-122; Ibn Aqil, 2005, Vol. IV, 91-111; Wright, 2005, Vol. I, 199-234). In his book ‘*Al-Kitaab*’, Sibawayh divides the plural of multiplicity into two types based on their productivity, which refers to the widespread use of a pattern among many Arab tribes. For a productive pattern, he uses the term ‘*qija:s*’, which means ‘standard’; however, if a pattern is less productive he uses the term ‘*sama:f*’, which means ‘heard’, referring to the fact that a pattern is used and associated with a specific tribe/tribes. In *Al-Kitaab*, the singular nominal patterns are listed according to their qualification to take a specific BP pattern. Although in *Al-Kitaab* an exhaustive list of BP patterns and their corresponding singular patterns or forms are given, there are few phonological and semantic accounts to justify the plural-singular mapping.

CA grammarians make a semantic distinction between SP and BP. SP is seen as the plural of nominal forms which denotes several distinct individuals within one group, while BP is the plural of nominal forms which denotes a number of individuals viewed collectively. That is to say, that a BP pattern is recognized as a singular form with a collective reference which has a nature similar to that of an abstract noun (Wright, 2005, Vol. I, 233):

(2)

Singular Form	SP	Collective Noun	BP
/baqar-at/, ‘cow’	/baqar-a:t/	/baqar/	/ʔabqa:r/
/tamar-at/, ‘date’	/tamara:t/	/tamar/	/tumu:r/

Non-human nouns usually take SP when they denote a plural of paucity (Samirrai, 2007, 127). The SP forms represented in the above examples denote the plural of paucity, which refers to a number of limited individuals, while both the collective noun and the BP refer to a

group of individuals. In fact, both a collective noun and a BP noun take a singular agreement. The only difference between them is the fact that a collective noun takes a masculine agreement, while a BP takes the feminine. Only SP forms are more likely to take plural agreement than BP. Thus, the number agreement reveals that BP is in fact a singular form referring to collective individuals (see Sibawayh, 1999, Vol. IV, 61-78, Belnap, 1999, cited in Greville, 2000, 209). SP in adjectives does not usually refer to the plural of paucity, but rather it denotes the action or activity which renders the state of the adjective closer to that of the verb. This is because adjectives take SP. However, for an adjective to take a BP it has to have the characteristics of the noun. In the example below taken from Samirrai (2007, 128), a singular adjective is given with its SP and BP forms:

(3)

Singular adjective	SP	BP
/qa:ʔid/, 'leader'	/qa:ʔidu:n/	/qa:d-at/

The following sentence shows that the adjective /qa:ʔid-u:n/ ending in SP expresses the action and activity carried by the noun /ʔal-qa:dat/. Though both the adjective and noun are grammatically close, since both are nominal forms, their grammatical categories are distinguishable by the way they form the plural. The SP suffix makes the adjective able to modify the head BP noun, while the ungrammatical form refers to the fact that a BP form cannot modify another BP form:

(4)

/ʔal-qa:dat	qa:ʔid-u:n/*qa:dat	dʒiju:ʃihim/
'The leaders	leading/leaders	their troops'
'The leaders (are) leading their troops'		

Hence, an adjective taking a BP form has to acquire the characteristics of the noun because nouns represent stable states while an adjective which takes SP is closer to the verb since verbs usually express actions and/or activities. In the following section, a set of BP patterns derived from their corresponding singular adjectives and associated with specific meanings are presented. By acquiring a new semantic meaning, all the singular forms move from the

adjective to the noun category when they take BP forms. This is due to the fact that adjectives acquire stable meanings which denote a state rather than an action, just like nouns.

### 2.1.1 Meanings Associated with some Templatic BP Adjectives

The specified meanings associated with some adjectival BP templates as accounted for by CA grammarians are listed in the forms below. In fact, the assignment of meaning could be related to the morpho-semantic interaction processes. This means that the semantic processes are morphologically assigned by the nature of some derivational morphological affixes which are identified semantically and hosted within the active morphological sites. Therefore, the idea of active morphological sites is not necessarily restricted to the pure morphological derivational processes motivated by the morphology, but more it could host semantic processes which can only be morphologically assigned as represented in the following BP forms (see more details in section 2.5).

#### 2.1.1.1 Form /C<sub>1</sub>uC<sub>2</sub>C<sub>2</sub>a : C<sub>3</sub>/

This templatic adjective signifies intensity and multiplicity which represent repetition, habit, and profession. The intensity of the action is morphologically identified by doubling the medial root consonant. It is very productive with the singular active participle adjective template CvvCvC which has C<sub>3</sub> as a sound consonant (which is a CA grammarian term used to refer to any consonant except glides). For example:

(5)

/ka:tib/, 'writer'	/kutta:b/
/t <sup>ʕ</sup> α:lib/, 'student'	/t <sup>ʕ</sup> ulla:b/
/ħa:sid/, 'envier'	/ħussa:d/

Thus, /kutta:b/ carries the meaning of the repeated action of writing as if it refers to a profession, /t<sup>ʕ</sup>ulla:b/ carries the meaning of a continuous repeated action of studying, and /ħussa:d/ denotes the continuous habit associated with the doer. Interestingly, in CA the templatic adjective of the singular that denotes intensity and

the templatic adjective plural as represented in the above examples has the same templatic structure (Samirrai, 2007, 131), as in /ħilla:q/, ‘barber’ (singular and denoting profession). Therefore, both templates share the meaning of intensity and multiplicity of the action carried out by the doer.

### 2.1.1.2 Form /CaCaC-at/

This template is very productive in masculine human adjectives which have the template /CvVCvC/ as a singular form, where C<sub>3</sub> is a sound consonant. If C<sub>3</sub> is not occupied by a sound consonant, then the expected plural form has the template /CuCaC-at/. For example:

(6)

/ka:tib/, ‘writer’	/katab-at/
/t <sup>ʕ</sup> ɑ:lib/, ‘student’	/t <sup>ʕ</sup> ɑlab-at/
/ka:fir/, ‘infidel’	/kafar-at/

If C<sub>2</sub> or C<sub>3</sub> of this template is not a sound consonant, either it contains /j/ or /w/ in the underlying structure (Wright, 2005, Vol. I, 207), then this adjectival template takes the shape /Ca:C-at/ or /CuCa:-t/. For example:

(7)

/ba:ʔiʔ/, ‘trader’	/ba:ʔ-at/
/qa:d <sup>ʕ</sup> i:/, ‘judge’	/qud <sup>ʕ</sup> a:-t/
/ʒa:ni:/, ‘sinner’	/ʒuna:-t/

The templates /CaCaC-at/, /Ca:C-at/, and /CuCa:-t/ identify a specific group of people and do not refer to the continuation or multiplicity of an action, but are closer to nouns than to adjectives since the suffix /t/ transforms the adjective into a noun (Samirrai, 2007, 132). Then, the difference between the adjectival template /C<sub>1</sub>uC<sub>2</sub>C<sub>2</sub>a:C<sub>3</sub>/ and the adjectival template /CaCaC-at/ is that the first denotes the

repetition and the continuation of the action, whereas the second does not refer to the action, but to the group of people who do that action. For example, the difference between /tʔulla:b/ and /tʔalab-at/ is that; the first refers to the intensive action carried out by students to seek knowledge, whereas the second refers to that group of students without a reference to the action of seeking knowledge.

### 2.1.1.3 Form /CuCCaC/

This template is very productive in masculine and feminine adjectives which have the templates /CvVCvC/ and /CvVCvC-at/ respectively. Although both /CuCCaC/ and /CuCCa:C/ describe the continuation and multiplicity of the action, the action of /CuCCaC/ is more observable and lasts for a limited time. For example:

(8)

/ħa:mił/, ‘pregnant’	/ħummal/
/ra:qid/, ‘asleep’	/ruqqad/
/rɑ:kiʔ/, ‘knee down’	/rukkaʔ/

### 2.1.1.4 Form /CaCa:CaC/

This template is associated with the plural of /CvVCvC-at/ either as a noun or an adjective, and also, as the plural of /CvCCvC/, the noun /CvVCvC/, the adjective feminine /CvVCvC/, /CvCCvC-at/, /CvVCaC/, and the adjective of the non-human /CvVCvC/. For example:

(9)

/ʔa:nis-at/, ‘bachelor female’	/ʔawa:nis/
/qa:lib/, ‘mould’	/qawa:lib/
/sa:lim/, ‘proper masculine name’	/sawa:lim/

As mentioned earlier, the adjective /CvVCvC-at/ takes the plural /CuCCaC/, which denotes action. However, if the adjective does not denote action, it qualifies to be

treated as a noun and takes the plural /CaCa:Ca:/ which is more productive in nouns (Samirrai, 2007, 136).

#### 2.1.1.5 Form /CuCCa:n/

This plural template is restricted to nouns. If the adjective takes this form, it signifies that it refers to a noun rather than describing any other entity. For example:

(10)

/ra:ʕi:/, ‘shepherd’	/ruʕja:n/
/ʔaʕma:/, ‘blind’	/ʕumja:n/
/fa:ris/, ‘knight’	/fursa:n/

#### 2.1.1.6 Form /CaCCa:/ and /CaCa:Ca:/

These plural templates are associated with verbal adjectives which denote injuries, defects and so on, of the body and mind (Wright, 2005, Vol. I, 218). For example:

(11)

/qati:l/, ‘slain’	/qatla:/
/majit/, ‘dead’	/mawta:/
/jati:m/, ‘orphan’	/jata:ma:/
/sakra:n/, ‘drunken’	/saka:ra:/

#### 2.1.1.7 Form /CuCaCa:ʔ/ and /CiCa:C/

These templates are very productive with verbal adjectives /CaCi:C/ which do not have the passive signification (Wright, 2005, Vol. I, 218). They are associated with masculine human beings. If /CaCi:C/ is geminated or lacks a sound root consonant, it takes the plural template /ʔaCiCCa:ʔ/ (Samirrai, 2007, 144) as in /t<sup>ʕ</sup>abi:b/, ‘physician’, ⇒ /ʔat<sup>ʕ</sup>ibba:ʔ/ and /ʕani:/ ‘rich’, ⇒ /ʔaynija:ʔ/. However, sometimes /CaCi:C/ receives the plural form /CiCa:C/, as in /kari:m/,



‘generous’, ⇒ /kɪrɑ:m/ and /tʰɑwɪ:l-at/ ‘long’ ⇒ /tʰiɰɑ:l/. The template /CuCaCa:ʔ/ signifies the meaning of natural or natural like self characters. Also /Ca:ʔiC/, sometimes, receives /CuCaCa:ʔ/, as in /ʃɑ:ʔir/, ‘poet’, ⇒ /ʃuʔara:ʔ/, /ʔɑ:lim/, ‘scholar’, ⇒ /ʔulama:ʔ/ and /ʒɑ:hi:l/, ‘ignorant’, ⇒ /ʒuhala:ʔ/. The common factor in /Caʔi:C/ and /ʔiCa:C/ above which qualifies them to receive /CuCaCa:ʔ/ is that the derivational adjectival morphemes /i:/ and /ɑ:/ both designate naturally gifted or natural-like characteristics.

### 2.1.1.8 Form /CaCa:ʔiC/

This template is the plural form of /CvCvC-at/ or /CvCvC/, as in /sʰɑhi:f-at/, ‘transcription’, ⇒ /sʰɑha:ʔif/ and /ʔɑzu:z/, ‘old woman’, ⇒ /ʔɑʒɑ:ʔiz/ respectively. Also, /Caʔi:C-at/ receives such a plural, but the difference between /Caʔi:C-at/ takes /CaCa:ʔiC/ or /ʔiCa:C/ is that /CaCa:ʔiC/ is a noun, whereas /ʔiCa:C/ is an adjective. For example, /sʰɑyi:r-at/, ‘small’, has two possible BP forms: the adjective /sʰiɰɑ:r/ and the noun /sʰɑʔɑ:ʔir/, ‘bad deeds’. Similarly, /kabi:r-at/ ‘big’, has the adjective /kibɑ:r/ and the noun /kaba:ʔir/, ‘great sins’, (Samirrai, 2007, 148).

## 2.2 Derivational Morphology

Inspired by the work of Chomsky and Halle (1968), Levy (1971) produced a rule-based account of BP formation. These rules are divided into two types: nine major and six minor rules. The difference between the two rule types is that the major rules have a wider range of use than the minor rules. The structural descriptions of some of these rules are interpreted with features such as [ $\pm$  abstract], [ $\pm$  rational], and [ $\pm$  adjective]. Nevertheless, some rules are marked phonologically without any feature specifications. The other difference between the two types is that the major rules are ordered linearly, while the minor ones are not.

### 2.2.1 Derivational Major Plural Rules

Major rules refer to the many transformational processes of assigning the plural. Such rules refer to both the applicability of a rule to many plural forms and the many phonological and lexical rules involved in the derivation of a plural form. Let us take the /CuCC/-Plural rule as an illustrative example. This plural form is associated with adjectives of colour and defects. It is derived from the masculine singular form /ʔaCCaC/ and its feminine form /CaCC-a : ʔ/. The other variant plural associated with some such adjectives is /CuCC-a : n/. The symbols used in the follow rules refer to: Sd = structural description, C= consonant, V= vowel, ø = null segment, # = boundary, and SC= structural change; with numbers showing the order of segments:

(12)

Sd: C a C a C # [+ Adjective Colour-Defect]

1 2 3 4 5

SC: 2 ⇒ /u/

4 ⇒ ø

/ħamar/, ‘red’ /ħumr/

/ʕamaǰ/, ‘blind’ /ʕumǰ/

/ħamra : ʔ/, ‘red (feminine)’ /ħumr/

Levy suggests that the underlying form of the masculine adjective singular is /CaCC/, which requires two phonological processes in order to surface as /ʔaCCaC/. The first is the epenthesis of /a/ between the second and the third root consonants, which yields /CaCaC/ as given in the preceding examples. The second is metathesis between the first root consonant and the first vowel, which yields /aCCaC/. Finally, an epenthetic glottal stop is inserted to fill the empty onset. This underlying form must be restricted to adjectives of colour and defect, otherwise a noun form such as /xabar/, ‘news’, which has the BP form /ʔaxbɑ : r/ may undergo phonological processes before it gets its surface form (Levy, 1971, 263). According to Levy, the input for the plural derivational process represented in the rule is not the surface singular /ʔaħmar/ but

rather its underlying structure /CvCvC/. The plural derivational process requires two phonological processes and one feature specification, which is [+ Adjective Colour-Defect]. Taking the feature specification as an initial constraint, the phonological processes follow two steps: the first inserts the back vowel /u/ in the second slot position and the second deletes the vowel in the fourth slot position. After all the phonological rules have taken place and all the relevant derivational processes are satisfied, the surfaced plural in the derivational approach is considered as a well-formed structure. In this illustrative example, the derivational process takes three steps; however, it may extend to many more in the major rules in order to justify the surfaced structure.

### 2.2.2 Derivational Minor Plural Rules

Minor rules mean that the derivational processes involve fewer transformational rules. There are certain groups of plural forms which are considered minor. In their formation of the plural, a few phonological processes apply to each BP form of this type. Therefore, the minor plural rules here refer to the limited number of plural forms associated with a single noun form as well as to the limited phonological rules that apply on those plurals. The most prominent plural forms are: /CiCa:C/, /CaCaC-at/, the doubled second root consonant /CuCCa:C/, /ʔaCCuC/, /CaCCa:(j)/, /CiCCa:n/ or /CuCCa:n/, and the doubled second root consonant /CaCCa:C-at/ and /CaCa:CiC-at/. Let us take the /CiCa:C/-Plural rule as an example to illustrate the process. This form is considered productive in Arabic and is associated with a wide range of singular forms. However, its occurrence is prominently linked to the non-rational, non-abstract /CaCC/ and /CaCC-at/, and rational /CaCC/, /CaCi:C/, and /CaCCa:n/ and its feminine /CaCCa:(j)/, especially when they function as adjectives (Levy, 1971, 300). For example:

(13)

Sd: a) C a C ø C #	[- Rational]
1 2 3 4 5	
/kalb/, 'dog'	/kila:b/

/ħabl/, ‘rope’                      /ħiba:l/

b) C a C i : C #      [+ Rational]

1 2 3 4 5

/kabi:r/, ‘big’                      /kiba:r/

/rafi:q/, ‘companion’      /rifɑ:q/

The structural descriptions of the singular forms for /CaCC/ and /CaCi:C/ are given in (13-a) and (13-b) respectively. In (13-a), the feature associated with the form is non-rational, while in (13-b) it is rational. These features have to be identified first; otherwise the correct derivational BP rule cannot be assigned. The corresponding BP forms represent the most productive BP patterns. Other BP patterns are also possible for (13-b) such as /CuCaCa:ʔ/, but /CiCa:C/ is more productive (Levy, 1971, 56). In (13-c), the derivational BP rule accounts for the singular forms /CvCC/ and /CvCvC/:

c) C v C (v) C #

1 2 3 4 5

/ʒabal/, ‘mountain’              /ʒiba:l/

/razul/, ‘man’                      /riʒa:l/

SC: 2 ⇒ /i/

4 ⇒ /a: /

The segment in parenthesis shows the absence or existence of the vowel. The structural change which represents the phonological assignment of the BP rule takes place by filling the second segment with /i/ and the fourth with /a: /.

The major and minor rules are complemented by the many phonological rules. The difficulty with Levy’s account is the number of the derivational rules needed in order to move from the input singular to the output derived plural. As a matter of fact, Levy’s account fails to give generalisations regarding the formation of BP, as she

herself admitted (1971, 358). Another reason to disregard this approach is the absence of any identification of the morphological processes. Because morphology was not considered as a component of grammatical theory in SPE, Levy limited the derivational processes of BP to phonology, syntax, and semantics, which can in no way alone account for the morphological nature of deriving the BP form from its corresponding singular form.

### 2.3 SP and BP Lexical Features Assignment

Abd-Rabbo (1988) investigated in an autosegmental framework what motivates nouns and adjectives to take BP or SP in CA. He claimed that the assignment of a type of plural to an input singular is determined by information outside the input's form (1988, 55). His account introduced two linguistic principles, both of which are claimed to have effects on plural formation. They are the number of consonants constraint (NCC) and avoid harmony (AH). NCC imposes a restriction on the number of consonants in the input forms in morphological operations; while AH entails some restrictions placed on derived homophonous forms to receive a similar plural type.

Although CA grammarians have listed the possible forms that can be associated with a specific plural, the identification and role of gender is still problematic in assigning the plural. The feature [human], for example, which is usually associated with a masculine sound plural and is thought to play a role in identifying whether a form takes BP or SP, seems to have no role in the examples below (Abd-Rabbo, 1988, 57). Consider the feature [ $\pm$  Human] and its role in assigning the kind of plural:

(14)

Singular Form	BP Form	Feature
/raʒul/, 'man'	/riʒa:l/	[+ Masculine, + Human]
/kalb/, 'dog'	/kila:b/	[+ Masculine, - Human]
/kuwr-at/, 'ball'	/kuwar/	[+ Feminine, - Human]

The feature [ $\pm$  Human] does not have a role in assigning the kind of plural here. In all the above mentioned examples, neither the feature [ $\pm$  Human] nor gender has a role in the resulting plural, whereas all the examples without exception take BP.

In the examples below, notice that the plural-of-plural takes the feminine plural suffix -a:t to assign the plural:

(15)

Singular	BP	Plural-of-Plural	Feature
/raʒul/	/riʒa:l/	/riʒa:la:t/	[+ Masculine, + Human]
/kalb/	/kila:b/	-	[+ Masculine, - Human]

However, although the follow noun has BP, it has another plural assigned as a feminine sound plural:

(16)

Singular	BP	Plural-of-Plural	Feature
/kuwr-at/	/kuwar/	/kura:t/	[+ Feminine, - Human]

Levy (1971) proposed the rule below to account for nouns and adjectives that do not take BP:

- (17) [- derived]  
 [+ Foreign]  $\Rightarrow$  [-BP]  
 [+ Alphabet Letter]  
 [+ a :<sup>un</sup> addition]

Based on this rule, singular nouns and adjectives which fall into these categories will not be assigned to BP. From the general principle in the rule above, the feature [derived] plays a role in assigning BP. However the data supplied below show that the feature [derived] may or may not take BP (Abd-Rabbo, 1988, 58):

Derived forms that take BP:

- |      |                             |             |
|------|-----------------------------|-------------|
| (18) | Singular                    | BP          |
|      | /madxal/, 'entrance'        | /mada:xil/  |
|      | /tafsi:r/, 'interpretation' | /tafa:si:r/ |

Derived forms that do not take BP:

- |      |   |                                  |
|------|---|----------------------------------|
| (19) | /mustaʃfa:/, 'hospital'                     | /mustaʃfa:y-a:t/                 |
|      | /falast <sup>ʕ</sup> i:n-iy/, 'Palestinian' | /falast <sup>ʕ</sup> i:niyy-u:n/ |

Underived forms that take BP:

- |      |                  |            |
|------|------------------|------------|
| (20) | /fiŋʒa:n/, 'cup' | /fanaʒi:n/ |
|------|------------------|------------|

Underived forms that SP:

- |      |   |                              |
|------|---|------------------------------|
| (21) | /ʔust <sup>ʕ</sup> wa:n-at/, 'cylinder' | /ʔust <sup>ʕ</sup> wa:n-a:t/ |
|------|---|------------------------------|

It seems that there are some factors which play a significant role in the assignment of the type of plural. Abd-Rabbo (1988, 60) reported some generalisations to capture whether a form should take SP or BP. The basic assumption is that all nouns take BP while adjectives take SP. However, this cannot be an accurate overall generalisation, since there are conditions that determine some adjectives to take BP and some nouns to take SP. The rule below may capture the generalisation that all nouns take BP regardless of their features:

- (22) [N] (Noun) ⇒ BP

This rule works as a starting point in Abd-Rabbo's account and it can be reformulated to account for pairs that are related by the feminine marker -at as well as to account for NCC. In CA, many nouns are closely related and the gender is assigned merely by

adding the -at to feminine nouns. For assigning the plural, the masculine noun [N] takes BP, whereas the feminine noun [N-at] takes SP. Abd-Rabbo (1988, 61) claimed that by taking BP this may motivate N to block N-at from taking the same plural. The pairs of N and N-at can be related in four ways:

- The two pair forms are biologically assigned for gender

(23)	Singular	SP	BP
	/kalb/, 'dog'	-	/kila:b/
	/kalb-at/, 'dog Fem.'	/kalb-a:t/	-

- The two pair forms may be related by some meaning relation derived from the general meaning of the root.

(24)	/maka:n/, 'place'	-	/ʔamkin-at/, /ʔama:kin/
	/maka:n-at/, 'position'	/maka:n-a:t/	-

- The two pair forms may be related as a singular and a collective noun

(25)	θala:θu naxl-a:t/*naxl, 'three palm trees'
------	--

The noun /naxl/ is considered as collective because it does not take a numeric determiner which is normally taken by the plural. Such nouns also fail to take the feminine singular agreement which is taken by BP in CA (Abd-Rabbo, 1988, 62). For example:

(26)	ha:ðihi ʔabqa:r, 'this (Feminine) is cows'. (BP form)
	*ha:ðihi naxl, 'this is palm trees'. (collective form)

The BP /ʔabqa:r/ agrees with the singular feminine determiner /ha:ðihi/, whereas the collective noun /naxl/ fails to take this agreement. In the following



examples, the collective nouns block N-at and take BP. This rule of blocking is present even though some collective nouns have no BP:

(27)	N-at Singular	N-a:t Plural	Collective Noun	BP
	/ʃazar-at/, 'tree'	/ʃazar-a:t/	/ʃazar/	/ʔaʃza:r/
	/naxl-at/, 'palm tree'	/naxl-a:t/	/naxl/	/naxi:l/
	/ward-at/, 'rose'	/ward-a:t/	/ward/	/wuru:d/

Although there is no rule that stops collective nouns from being pluralized, the examples below show that the presence of collective nouns is enough to block N-at from taking BP (Abd-Rabbo, 1988, 63):

(28)	N-at Singular	N-a:t Plural	Collective Noun	BP
	/tuffa:ħ-at/, 'apple'	/tuffa:ħa:t/	/tuffa:ħ/	-
	/fiʒl-at/, 'radish'	/fiʒl-a:t/	/fiʒl/	-
	/daza:ʒ-at/, 'hen'	/daza:ʒ-a:t/	/daza:ʒ/	-

- In some cases N and N-at are not transparently related:

(29)	N and N-at singular	Pluralization form
	/θawr/, 'ox'	/ʔaθwa:r/, /θijra:n/
	/θawr-at/, 'revolution'	/θawr-a:t/

In all the four groups mentioned, N-at takes -a:t plural. However, in many cases nouns of the form N-at takes BP and not -a:t plural whenever the form N is not present. In the examples below, all the singular forms have N-at and they lack N and they are represented as \*[N]-at in the following examples:

(30)	*[N]-at	Pluralization form
	*/madrās-at/, 'school'	/mada:ris/
	*/ʔazi:m-at/, 'will power'	/ʔaza:ʕim/
	*/buqʕ-at/, 'spot'	/buqʕ/

\*/kilw-at/, 'kidney'                      /kila:wi/

In all these examples, the non-existence of the form [N] has led \*[N]-at nouns to take BP because the slot for this type of plural is available (Abd-Rabbo, 1988, 64). The generalisation that nouns take BP now needs some modification in order to express the behaviour of N and N-at pairs:

(31)     [N]            ⇒ BP  
           [+Masc.]  
           [\*{N}-at]

In this rule, the two nouns which qualify for BP are a masculine noun or a feminine noun which does not have a masculine correspondent. However, if the \*[N]-at noun consists of more than four consonants, it takes -a : t plural.

Many grammatical categories in CA are constrained by NCC. In the example below, although the noun does not have a masculine correspondent and it is qualified to receive BP, it has been forced by NCC to receive -a : t plural (Abd-Rabbo, 1988, 64):

(32)	*[N]-at	Masculine Form	SP	BP
	/ʔust <sup>ʕ</sup> wa:n-at/ 'cylinder'	*/ʔust <sup>ʕ</sup> wa:n/	/ʔust <sup>ʕ</sup> wa:n-a:t/	-

For the verbal nouns (VN), the constraints proposed for base or non-derived nouns are applicable to account for VN pluralization. These VNs can have between three to five consonants. Constrained by NCC, only quinqueliteral (QqL) VNs take /a : t/ plural, whereas trilateral (TL) and quadrilateral (QL) take BP:

(33)	TL VN	BP
	/ʔamal/, 'work'	/ʔaʔma:l/
	/nid <sup>ʕ</sup> a:m/, 'system'	/ʔand <sup>ʕ</sup> im-at/

QL VN	BP
/tafsi:r/, ‘interpretation’	/tafa:si:r/
/zilza:l/, ‘earthquake’	/zala:zil/
QqL VN	-a:t plural
/ʔistit <sup>ʕ</sup> la:ʔ/, ‘reconnaissance’	/ʔistit <sup>ʕ</sup> la:ʔ-a:t/
/ʔimtida:d/, ‘extension’	/ʔimtida:d-a:t/

The NCC constraint rule is represented as follows:

- (34) [N]<sup>TL/QL</sup> ⇒ BP  
 [+Masc.]  
 [\*[N]-at]

This constraint accounts for TL and QL nouns which take BP without violating NCC. Such nouns receive BP if they are masculine, or if they are feminine but lack masculine correspondents. Abd-Rabbo argued that BP-SP assignment involves information beyond the singular noun. The arguments which have been presented so far militate against treatment centred exclusively on the form of the singular noun. SP masculine and feminine nouns are normally assigned to masculine-feminine pairs of adjectives related by -a:t (Abd-Rabbo, 1988, 66):

(35)	Adjective	Masculine SP	Feminine SP
	/ħa:ðiq/, ‘clever’ masc.	/ħaaðiq -u:n/	-
		/ħaaðiq -i:n/	-
	/ħa:ðiq-at/, ‘clever’ fem.	-	/ħaaðiq-a:t/

Such pairs of adjectives related by -a:t are represented as plus-at [+a:t]. Those adjectives which are not so related are represented as minus-at, or [-a:t], and they take BP. There are three kinds of [-a:t] adjectives:

- Adjectives not specified for gender (masculine is the unmarked value)

(36)

Singular	BP
/s <sup>ɪ</sup> abu:r/, 'patient'	/s <sup>ɪ</sup> ubur/
/qati:l/, 'murdered'	/qatla:/

- adjectives that do not have masculine correspondents

(37)

Singular	BP
/ħubla:/, 'pregnant'	/ħaba:la:/
/ħa:mil/, 'pregnant'	/ħawa:mil/

- Feminine and masculine adjectives that are morphologically related by feminine markers other than –at, which are –a: and -a:ʔ.

(38)

Singular	BP	Feature
/ʔaħmar/, 'red'	/ħumr/	masc.
/ħamra:ʔ/, 'red'	/ħumr/	fem.
/sakra:n/, 'drunk'	/suka:ra:/	masc.
/sakra:/, 'drunk'	/suka:ra:/	fem.

Now, the rule to capture a generalisation for the pluralisation of adjectives states that [-at] adjectives, or those which are related by a feminine marker other than -at, take BP:

(39)

Adj	⇒ BP
[-at]	

It has been suggested by Abd-Rabbo so far that [+at] adjectives receive SP, while [-at] adjectives receive BP. Nevertheless, it seems that some [+at] adjectives take BP. These adjectives receive SP when they refer to a specified gender. In the case of

the BP, the gender is not specified but rather it refers to a group of people of mixed sexes (Abd-Rabbo, 1988, 67):

(40)	Singular	SP	BP
	/kari:m/, ‘generous’	/kari:m-u:n/	/kiri:m/
		/kari:m-i:n/	/kiri:m/
	/kari:m-at/	/kari:m-a:t/	/kiri:m/

To account for the feature [-Gender] the rule for adjectives is remodified:

(41)	Adj	⇒ BP
	[-at]	
	[-Gender]	

In deriving adjectives, the feature [+nominal] plays a role in assigning such derived adjectives to take BP:

(42)	Adj	SP	BP
	/maʃu:q/, ‘crushed, Masc.’	/maʃu:q- u:n/	-
	/maʃu:q- at/, ‘crushed, Fem.’	/maʃu:q- a:t/	-
	/maʃu:q/, ‘powder’	-	/masa:hi:q/
	/tʃa:lib/, ‘asking, Masc.’	/tʃa:lib-u:n/	-
	/tʃa:lib-at/, ‘asking, Fem.’	/tʃa:lib-a:t/	-
	/tʃa:lib/, ‘student, Masc.’	-	/tʃulla:b/
	/tʃa:lib-at/, ‘student, Fem.’	/tʃa:lib-a:t/	-

Similar to the behaviour of nouns, nominalised adjectives which have one form take BP. Furthermore, nominalised adjectives which have feminine and masculine forms are assigned to the plural as masculine forms which have the priority to be assigned to BP, whereas feminine forms take -a:t plural, as in the instance of /tʃa:lib/, ‘student’. The rule covers the generalisation presented so far for adjectives:

- (43) Adj ⇒ BP  
 [± at]  
 [- Gender]  
 [+ Nom, +Masc/\*[N] -at]

There are some other restrictions imposed on BP quadrilateral adjectives derived from trilateral forms. The examples below illustrate quadrilateral adjectives and their behaviour. It must be noted that Abd-Rabbo used the term quadrilateral in an unusual sense. He accounted for the derivational consonant affixes as part of the root consonants of the word. This means that he did not distinguish between the main string of root consonants and the affixes which are usually supplied by different derivational morphological processes.

Major types of QL adjectives (Abd-Rabbo, 1988, 71):

(44)	QL adjective type	Adjective
	Form I passive adjectives	/maksu:r/, 'broken'
	Form II passive adjective	/mukassar/, 'smashed'
	Form II active participle	/muḥallim/, 'teacher'
	Form II noun of profession	/naḡḡa:r/, 'carpenter'

Adjective of exaggeration /mit<sup>ʕ</sup>la:q/ 'one who has divorced many times'

Form III active participle	/muqa:til/, 'fighter'
Form III passive participle	/muqa:tal/, 'being fought'
Form IV active participle	/munzil/, 'descended'
Form IV passive participle	/mut <sup>ʕ</sup> im/, 'feeder'

Quadrilateral adjectives qualifying for BP forms are given in the examples below:

(45)	QL adjective type	Adjective	BP
	Form I passive adjective	/maksu:r/	/maka:si:r/
	Adjectives of exaggeration	/mit <sup>ʕ</sup> la:q/	/mat <sup>ʕ</sup> a:li:q/

The form I QL passive adjective takes QL BP if it is nominalised and unspecified for gender ( $\text{maksu:r-at} \Rightarrow \text{maksu:r-a:t}$ ). QL adjective of exaggeration can qualify for BP. Templatic adjectives /CuCaaC(v)C/ do not take BP, though they qualify for it since the number of consonants is four. Abd-Rabbo suggested that such behaviour can be explained by ‘invoking AH and degree of lexicalization or facts of use which do not require the genderless sense’ (Abd-Rabbo, 1988, 71). The case  $\text{muqaatil}$  which takes BP is given as:

(46)	Singular Form	QL BP
	$/\text{muqaatil}/$ , ‘fighter (adj.)’	$*/\text{maqa:til}/$
	$/\text{maqtal}/$ , ‘fatal place in the body (Noun)’	$/\text{maqa:til}/$

As can be seen from the examples, the two words from different categories could have an identical pluralized word ( $\text{maqa:til}$ ). Because nouns have priority over adjectives to qualify for BP, and because of AH, the noun ( $\text{maqtal}$ ) is assigned to BP. Furthermore, the adjective ( $\text{muqa:til}$ ) is blocked from forming BP because of two factors: the first is AH; the second is the fact that this adjective has a genderless sense, since the word ‘fighters’ is always associated with men. The degree of lexicalization may prevent the formation of BP in cases where adjectives are used as nouns. The word  $/\text{mura:sil}/$ , ‘correspondent/messenger’, which has the same template as  $/\text{muqa:til}/$ , does not undergo BP. Abd-Rabbo assumed that because this is a newly nominalised form, this could be the reason for not qualifying for BP (Abd-Rabbo, 1988, 71).

The two adjectives of Form IV mentioned earlier have four consonants each in the surface structure. However, in the case of an active participle (AP), it seems that at some derivational stage the word  $/\text{munzil}/$  has five consonants. Consider the template mapping for the word  $/\text{munzil}/$ :

(47)

Prefixes	m		ʔ				
Vowel melody		u		a			i
Template	C	v	C	v	C	C	v
Root					n	z	l
Output	m	u		n	z	i	l

There are two affixational processes involved here, the first is prefixing /ʔ/ to form /ʔanzal/, then prefixing the AP marker /m/ to form /muʔanzil/. The form later follows a phonological rule that deletes /ʔa/ to produce the surface form /munzil/. The only way for nominalised APs to qualify for BP is to have four consonants. However, some other AP members do not qualify for BP. This could be related to the fact that their plurals end up as homophonous with plurals of place nouns. Below, both singulars could qualify for BP; however the problem is that they both have identical plurals. Since place nouns have priority over APs to form BP, /maʔman/ is given priority over the AP /muʔmin/ in taking BP. Thus, the same explanation applies to /munzil/ and /mut<sup>ʕ</sup>ʕim/ which take BP when they refer to an unspecified gender:

(48)	Singular	BP	SP
	/muʔmin/, 'believer'	*/maʔa:min/	/muʔmin-i:n/ /muʔmin-u:n/ /muʔmin-a:t/
	/maʔman/, 'shelter'	/maʔa:min/	-

Generally, quinqueliteral adjectives do not qualify for BP due to the NCC constraint. Since gender has no role in assigning BP, these adjectives take masculine SP in general unless there is a need to clarify the meaning, so that both masculine and feminine SP may be used (Abd-Rabbo, 1988, 73) as follows:

(49)	Singular	BP	MSP	FSP
	/mustaʕzil/, 'in hurry'	*/masa:tiʕ/ */masa:tiz/	/mustaʕzil-i:n/ /mustaʕzil-u:n/	/mustaʕzil-a:t/



It is similarly the case with nominalised quinqueliteral adjectives where they favour feminine SP –a : t over BP:

(50)	Singular	SP
	/mutanazzah/, ‘park’	/mutanazzah-a:t/
	/mustaʃfa:/:, ‘hospital’	/mustaʃfaay-a:t/
	/muztamaʕ/, ‘society’	/muztamaʕ-a:t/

Counting prefixes and suffixes when applying NCC may be problematic in identifying the roots from which meaning is interpreted. For example, the word /muztamaʕ/, which has the prefix mu-, brings the number of consonants to five. Applying NCC would delete the last consonant /ʕ/ which is part of the root /ʕmʕ/. It seems that NCC is a high-ranked constraint in CA; however, in some derivational processes this constraint has to be modified in such a way that targets only the possible truncated consonants. Other kinds of adjectives attached to some kinds of suffixes do take BP. The formation of these adjectives involves the adjectival suffix -iyy attached to nouns to produce nominalised adjectives known as *Nisba* (or relative) adjectives. If *Nisba* adjectives consist of three or four consonants before attaching the *Nisba* suffix, then they take, BP, as in:

(51)	Singular	BP
	/misʕr-iyy/, ‘Egyptian’	/masʕa:riw-at/
	/ʕabqar-iyy/, ‘genius’	/ʕaba:qir-at/

But if the *Nisba* adjective has five or more consonants, then it takes SP (Abd-Rabbo, 1988, 75) as the examples below show:

(52)	Singular	SP
	/ʔiskandara:n-ijj/, ‘Alexandrian’	/ʔiskandara:n-ijj-u:n/
	/tʕara:bul-s-iyy/, ‘Tripolitanian’	/tʕara:bul-s-iyy-u:n/

However, there is a BP form associated with *Nisba* adjectives which is formed by attaching the feminine suffix /at/, as the examples below show:

(53)	Singular	BP
	/ʔiskandara:n-ijj/	/ʔiskandara:w-ijj-at/
	/tʔara:bul-s-ijj/	/tʔara:bul-s-ijj-at/

However, a limited number of quinqueliteral nouns do take BP. In this case, a consonant is deleted in favour of forming BP:

(54)	Singular	BP
	/farazdaq/, 'a loaf of bread'	/fara:zid/, /fara:ziq/

As can be seen from the two candidates for BP, in /fara:zid/ the /q/ is deleted and in /fara:ziq/ the /d/ is deleted.

There is a group of nominalised adjectives known as 'nouns of profession' which exhibit gemination. These adjectives generally take masculine SP, and sometimes take feminine SP. Nominalised adjectives taking SP are represented below:

(55)	Singular	SP
	/naʒʒa:r/, 'carpenter'	/naʒʒa:r-u:n/
	/xabba:z/, 'baker'	/xabba:z-u:n/
	/mudi:r/, 'director'	*/mudi:r-u:n/

The feature [+Human, +Masculine] for this group cannot justify why these nouns take SP, since the nominalised adjective /mudi:r/ which has the feature [+Human, +Masculine] does take BP (Abd-Rabbo, 1988, 76). Furthermore, some non-human nouns which have the same template do not take BP, but rather SP -a:t:

(56)	Singular	SP
	/xazza:n/, 'reservoir'	/xazza:n-a:t/

/barra:d/, ‘refrigerator’

/barra:d-a:t/

In these examples, only the active participle II and noun of profession take SP. It should be noted that the adjective nouns that qualify for BP can also take SP. In this case the SP reflects a quantity less than ten (Abd-Rabbo, 1988, 78-79).

## 2.4 Templatic Morphology

In templatic morphology (McCarthy, 1979, 1981; Yip, 1988; Hammond, 1988), vowels (V) and consonants (C) are treated as separate autosegments on different tiers. Each of these tiers, it is assumed, contains information about only one morpheme. The two tiers are associated with an abstract morpheme in which the components of the tiers are combined together as CVs. This abstract morpheme is known as the CV-skeleton. Since Arabic consonants and vowels carry meaning, the abstract CV morpheme can be represented as a static skeletal morpheme (Hammond, 1988, 2). The skeletal morpheme is often referred to as a template which consists of syllabic positions (Lowenstamm and Jonathan, 1986) and it also is assumed to represent a prosodic structure (McCarthy and Prince, 1986, 1990b). Consider the representation of the Form I verb /daras/ ‘he studied’:

(57)

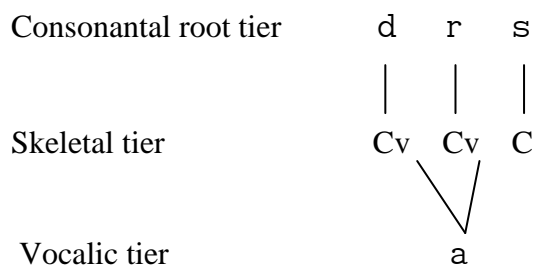

Thus, templatic morphology is based on root-and-template morphology where, for example, the consonants of a singular root are mapped onto a specific plural template.

McCarthy (1979) argued that the root consonants of a singular noun are mapped onto a BP template based on the rules supplied in the table below, where the mapping is left-to-right. The vowel in brackets in the plural form is long only if the singular has a

long vowel at the end of the root. Furthermore, McCarthy suggested that vowel melody for the plural is /a-i/. Firstly, /i/ is mapped onto the final syllable of the plural template, and secondly, /a/ is mapped to the first two syllables:

(58)

Singular Pattern Rule	Singular Noun	Plural Pattern Rule	Plural Noun
CvCCv(v)C	ʒundub (locust)	CvCv̄vCv(v)C	ʒana:dib
	miʔta:h (key)		mafa:ti:h

In addition, McCarty accounted for the singular root which has five consonants by the same rule:

(59)	Singular Noun	BP
	/ʕankabu:t/, 'spider'	/ʕana:kib/

The explanation given here is based on left-to-right mapping. That is, the extra-metrical consonants are lost because they do not fit into the plural pattern /CvCv̄vCvC/. However, this account of templatic morphology was later completely modified by the prosodic morphology approach in McCarthy and Prince (1990a, 1990b); see section 2.6 below.

Hammond (1988), in a similar account to that of McCarthy's templatic account, noted that there is a templatic transfer from the singular to the plural form. He explained that the length of the final vowel of the plural depends on that of the singular. Furthermore, the plural preserves the patterns of consonantal spread of the singular, as in (sɪkki:n 'knife'/saka:ki:n). He suggested an analysis based on melodic transfer where the plural template is [CvCv̄vCv̄vC] and the plural vowel melody is [a-i]. This template is aligned and then associated with the singular template. However, when a final vowel in plural template is not linked to a singular template, it is deleted.

McCarthy and Prince (1990b) noted that the shape of the plural depends on the prosody of the singular stem. The number of moras in the base directly determines the

number of syllables in the plural. In addition, they assumed that triconsonantal singulars with a long vowel require a default consonant /w/, which is surfaced as /ʔ/ in specific phonological environments. The position of this consonant is determined by that of the long vowel in the base of the singular as can be seen as follows:

(60)

Singular	Plural	Prosody of base	Gloss
naʃs	nufu:s	bimoraic	‘soul’
saħa:b+at	saħa:ʔib	trimoraic	‘cloud’
ʒa:mu:s	ʒawa:mi:s		‘buffalo’

All these properties of the singular are transferred to the plural. For instance, these properties are vowel quantity, number of syllables, and consonant spreading. This draws out the main difference between the account of templatic transfer and the account of prosodic morphology in accounting for the BP. In root-and-template derivational morphology, attention is only paid to the consonants of the root which are transferred to the target canonical form of a verb or noun in a prosodically different set, as in [kiʔa:b, katab, ka:tib, etc.]. Further supporting evidence for the inappropriateness of the templatic root comes from the derivational affixes which are also transferred to the plural form, as below:

(61)	Affix	Root	Singular Form	BP Form
	t-	[qdr]	/taqdi:r/, ‘calculation’	/taqa:di:r/

Further evidence comes from the ‘plural-of-the-plural’ formation where the BP itself is formed from a stem that is already a BP (McCarthy and Prince, 1990b, 220):

(62)

Root	Singular	Plural	Pl./Pl.	Pl./Pl./Pl.
[frq] ‘sect’	firq+at	firaq	ʔafra:q/fara:q/	ʔafa:ri:q

The plural of [firq-at] is [firaq] and the plural-of-the-plural is [fara:q], metathesized to [ʔafra:q] by inserting [ʔ] to fill the empty onset formed by the [Ca] metathesis. The metathesized plural-of-the-plural is treated as the input of the

plural-of-the-plural-of-the-plural [ʔafa:ri:q], in which the inherited long vowel is also transferred from [ʔafa:rɔ] and not from the singular. McCarthy and Prince concluded that ‘the iambic plural is related directly to the actual stem from which it is formed, not to the root of that stem’.

## 2.5 Active Derivational Morphological Sites

Arabic as a non-concatenative type language exhibits some internal adjustments which affect both the consonants and the vowels of the derived word. Idrissi (1997) and Kihm (2006) argued that concatenation need not be only of segments, but there are also within the word some abstract elements called by Idrissi ‘derivational head positions’ and by Kihm ‘sites’. These sites are identified as the site of morphological processes such as affixation and apophony. The other assumption put forward by Kihm was that the formal diversity of the shapes and the vowels of BP does not help in predicting the plural of a given singular and vice-versa, and it also does not make sense to treat /u:/ and /a:/, for example, as allomorphs of the plural morpheme identified in English as /-s/, /əz/ and /z/ (Kihm, 2006, 71). Although there are some words in English where the plural form is derived by changing the quality of the vowel, as in /foot/ ⇒ /feet/, in CA the BP is derived not by changing the quality of the vowel but, rather, in general by adding a new mora, as in /ʔisr/ ‘bridge’ ⇒ /ʔsu:r/ ⇒, through vowel harmony /ʔusu:r/. Thus, the mora /u:/ is not transferred from the singular but new material is added to the singular in order to form the BP (identifying the derivational site). Similarly, in /kalb/ ‘dog’ ⇒ /kla:b/ ⇒ /kila:b/, the added mora is /a:/. However, in /kita:b/ ‘book’ ⇒ /kutub/, the BP is realized by these two short /u/s, although the singular has /a:/. The CA nouns mentioned above exhibit diversity in the way they form BP, but they do share something in common. All of the different newly added materials mark the plural form appear in the derived word form (Kihm, 2006, 71). The position of the new added material is inserted between C<sub>2</sub> and C<sub>3</sub> of the root consonants.

### 2.5.1 Root-and-Site Hypothesis

Based on their study of CA verb derivation and inflection, Guerssel & Lowenstamm (1990) suggested that the structure of the underlying verbal derivation is a template which consists of two parts: the first is the base (root) which consists of root consonants, and the second is the sites or derivational head positions which host morphological processes. Later, this idea was extended to account for CA BP formation by Asfour (2001 cited in Kihm, 2006). Throughout this thesis the term ‘site’ and not ‘head’ is used since ‘site’ refer to the place in which it is easier to observe all the morphological activities which are hosted within the active morphological sites. ‘Head’ refers only to two active morphological positions; one internal and the other external. Consequently, ‘site’ gives more flexibility in accounting for both individual and multi morphological processes at the same time. Sites draw a distinction between concatenative and non-concatenative morphology: in the former, the sites are external and identified as either prefixes or suffixes; whereas in non-concatenative morphology the sites are internal and are identified as infixes. In Guerssel & Lowenstamm (1990), it is assumed that the underlying syllable structure of CA is maximally CV. The example below represents the basic syllable structure for the finite verb /kaːtˤaba/, ‘he wrote’:

(63)

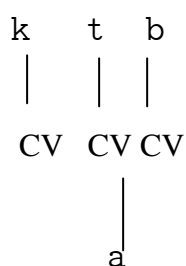

The consonant segments are linked to the C slots in the template. Because the Form I finite verb is distinguished by the vowel /a/, then a vowel-spreading process takes place to fill all the V slots in the template. Guerssel & Lowenstamm (1990) argued that, in Form I verb; only the second vowel has a morphological function. The last vowel is lost in a pause at the word level and is only identified as a syntactic property at the phrase level. The first vowel is supplied by default. The identification of a

morphological site for the derivation of Form II from Form I verbs is presented below. There is an additional CV slot inserted between C<sub>1</sub> and C<sub>2</sub>, and this site is morphologically associated with the Form II verb:

(64)

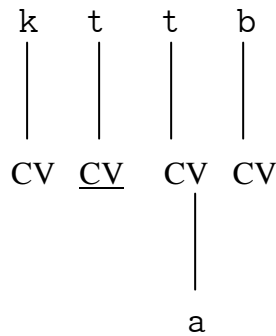

The underlined CV is the active morphological site which is activated to host the derivational process of Form II. Thus, the added CV slot provides a site for C<sub>2</sub> to extend in order to mark gemination, which represents the intensive feature associated with Form II verbs. Since the assumption about identifying the derivational sites is based on the CV maximal syllable structure in CA, it is worth presenting the possible structures of segments: a single segment, whether a consonant or a vowel, is presented as follows and the segments between slashes are just for illustration:

(65)

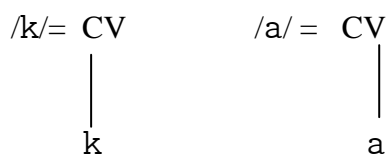

The sequence of consonant and vowel is as follows:

(66)

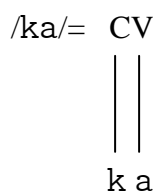



Geminated or doubled segments, whether consonants or vowels, are illustrated as follows. It must be noted that any unparsed slots are not realized at all levels:

(67)

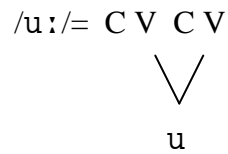
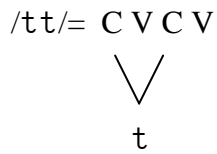

A general template has been suggested to account for verb morphology in Arabic. In this template, the two assumed heads are claimed to host the derivational process of Arabic verbs. Thus, these two heads are the sites for generating new lexical materials, that is to say, a new verbal form:

(68)

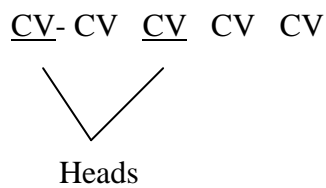

This template is constructed from three CVs which refer to the nuclear base form of trilateral verbs and two underlined CVs which refer to the derivational head positions. Thus, the realization of one of the heads triggers the derivation of another verbal form. The derivation of the verb Form /n-kat̩ab/, ‘it is written’, from the trilateral root verb /k̩t̩b/ requires the addition of one CV to host the derivation of this Form:

(69)

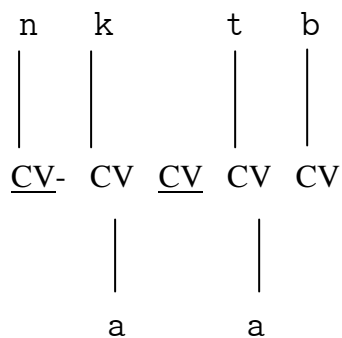

In the diagram, the first CV is identified by the Form VII verb, which is filled by the morpheme /n/. The base three CVs are filled by the trilateral root /ktb/. The first vowel /a/ marks the perfective, and the second is inserted by default (Idrissi, 1997, 127). In addition, the first prefixal CV is sometimes identified by the root to form the trilateral Form IX verb, which is derived from adjectives denoting colour or physical faults as in /xd<sup>ʕ</sup>arr/, ‘to be or become green’, ⇒ /ʔaxd<sup>ʕ</sup>arr/:

(70)

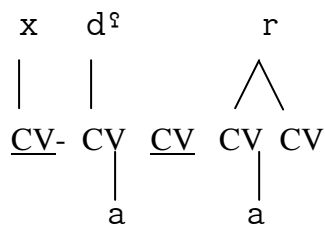

As can be seen from this template, the prefixal CV is identified by the first consonant root. In this template, and the previous templates, the consonants /n/ and /x/ which occupy the prefixal CVs are considered to be the codas for unparsed syllables. These unparsed syllables are repaired and filled by the epenthetic glottal stop /ʔ/ at the spellout representation. Another template pattern is assumed where the internal derivational site is identified by the root. This becomes clear if we compare the Form I /waqaf/, ‘he stopped’, trilateral verb template to the Form IV /wqaf/ > /ʔawqaf/, ‘he caused somebody to stop’, trilateral verb template. Form IV is often the causative of Form I:

(71)

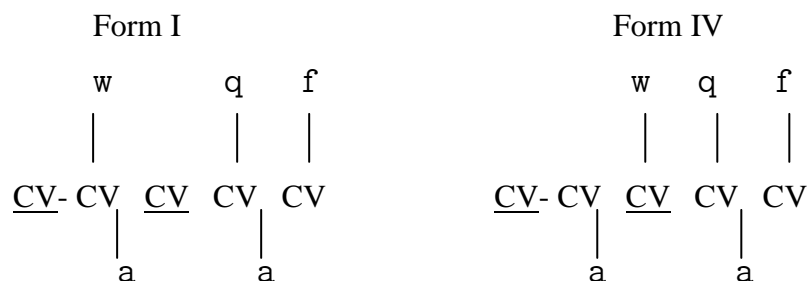

As can be seen, all the derivational processes take place within the word stem. The main difference between the two verb forms is that Form IV identifies the internal

derivational site and creates an epenthetic /ʔ/ within the stem word, whereas Form I does not identify any of the available derivational heads.

So far it has been claimed that the identification of the head derivational site is identified and filled by a consonant. However, the spreading of a consonant or a vowel also functions as a derivational process in Arabic. In the following examples the doubled consonant and the long vowel are distinguished as morphemes which mark the derivation of the Form II /kaʔtʔab/, ‘he caused somebody to write’, and the Form III /kaːtʔab/, ‘he corresponded’, trilateral verbs respectively:

(72)

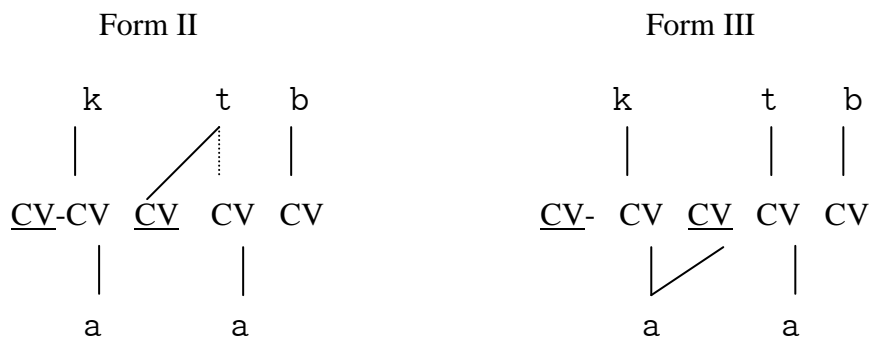

In Form II, /t/ spreads to fill the internal derivational site, that is, the C in the internal derivational site. On the other hand in Form III, /a/ spreads to fill the internal derivational site, that is, the V in the internal derivational site. Apophony is also an active derivational tool in Arabic verbal morphology: the main distinction between Arabic perfective and imperfective verbs is in vowel quality. For example, the perfective and imperfective of the root /ktb/, ‘write’, are respectively /katʔab/ and /jaktʔub/. Regardless of the prefix that marks the imperfective, vowel quality internally distinguishes both paradigms. The perfective here is distinguished by /a/ and the imperfective by /u/.

Idrissi (1997, 129) argued that plural formation exhibits the same strategies, identifying the derivational head positions and apophony, which is assumed for verbal morphology. The classical assumption for plural formation in Arabic assumes that regular plurals are derived from their corresponding singulars by a productive process

of suffixation, whereas irregular plural forms are derived in unpredictable ways from their corresponding singulars. Idrissi claimed that irregular plurals may be derived through the identification of either the prefixal or the internal derivational site, or otherwise through suffixation. Idrissi assumed that the BP in Arabic is built on a nominal template. This template consists of a base and two derivational head positions. The base is made of a maximum of five CV syllables and a minimum of three. The maximum nominal template is given as follows:

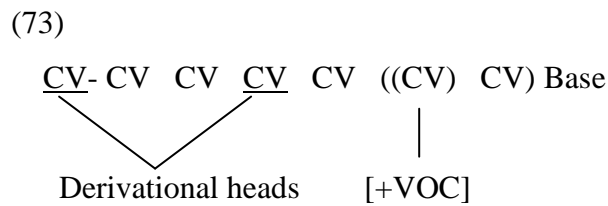

The number of Cvs in this nominal template represents the maximal CV position permitted in Arabic. Singulars that have five CVs such as /q̄indi:l/, where the long vowel is hosted in two CVs, select the five-CV base. The penultimate CV is always linked with a vocalic element. Singulars with four CVs such as /markaz/ select the whole base excluding the penultimate CV. Nouns that have three CVs choose the whole base excluding both parenthesized CVs. The examples below taken from Idrissi to illustrate his argument:

(74)	Singular Form	BP Form
	/θaʕlab/, 'fox'	/θaʕa:lib/
	/fa:kih-at/, 'fruit'	/fawa:kih/
	/dʒazi:r-at/, 'island'	/dʒaza:ʕir/
	/q̄indi:l/, 'lamp'	/qana:di:l/
	/ʕandali:b/, 'nightingale'	/ʕana:dil/

All these plurals have something in common in that their second syllables display the insertion of a long vowel. Idrissi claimed that the insertion of the long vowel reflects the identification of the internal derivational site of the plural template. When the singular is mapped onto the appropriate base, the following representations of the above singulars and plurals are given as follows:

The representation of singular /θaɪlab/ vs. its plural /θaɪa:lib/:

(75)

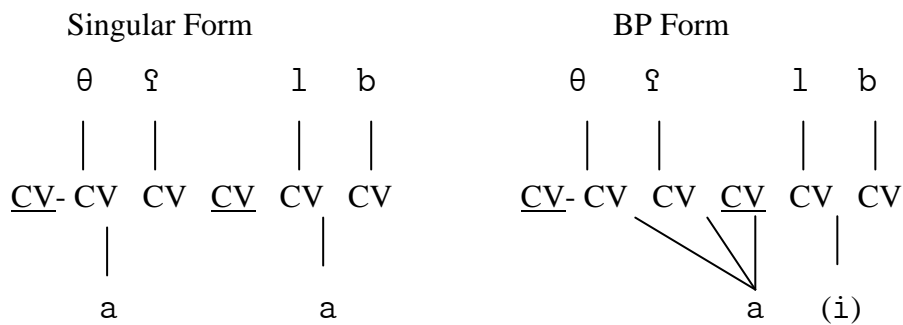

The quadrilateral BP is formed through the identification of the internal derivational site by the infixed vowel /a/. The vowel melody of the singular is assumed to be overwritten by that of the plural. The vowel melody is assigned first by /a/ which spreads to fill any preceding slot at the phonological level. Secondly, the parenthesized /i/ is inserted by default to replace the second vowel of the singular. Both /a/ and /i/ are considered to be inserted by default; /a/ is inserted at the morphological level and /i/ is inserted at the phonological level. This idea is different from that of McCarthy and Prince (1990b) who assumed that the vowel melody [/a/, /i/] is lexically supplied. In their argument, the vowel melody of the iambic circumscribed plural template (kernel) is mapped into the three first vowel positions, that is, /a/ yielding /CaCa:/, and any vowel in the residue is mapped to /i/ (Idrissi, 1997, 131).

The representation of singular /fa:kɪh-at/ vs. its plural /fawa:kɪh/:

(76)

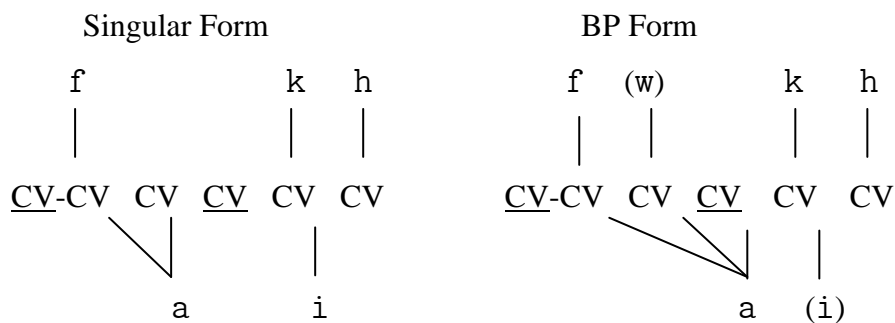

In the BP form, when the internal derivational site is identified by /a/, it spreads to occupy the preceding vowel slots in the first and second syllable positions. However, the onset of the second syllable is unassociated, and to fill this position /w/ is inserted by default.

The representation of singular /dʒazi:r-at/ vs. its plural /dʒaza:ʔir/ is as follows:

(77)

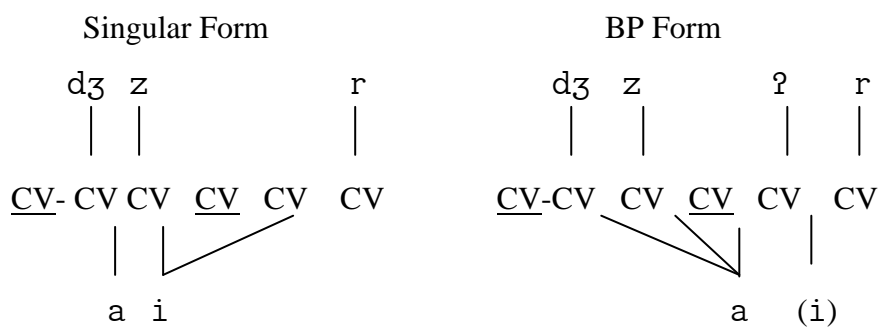

In a manner similar to the derivation of the preceding plural, the spreading of /a/ fills the vowel slots of the first and the second preceding syllables. However, the position of the epenthetic glottal stop is inserted in the penultimate CV, which lacks an onset. This epenthetic glottal stop is realized as /w/ at the underlying structure but it surfaces as /ʔ/. This is because the glide picks up the features of the preceding high vowel both in the singular and the plural. Thus, the singular is underlyingly realized as /dʒaziwr-at/ ⇒ /dʒazijr-at/ and the plural is realized underlyingly as /dʒaza:wir/ ⇒ /dʒaza:jir/. Then, a postlexical operation changes /j/ to /ʔ/ (Idrissi, 1997, 132). Idrissi assumed that it could be sufficient to consider surface long vowels in Arabic nouns as underlyingly represented as glides. That is to say, /risa:l-at/ and /ʔazu:z/ have either /aw/ or /uw/ underlyingly. So, at the surface level, they are represented as /risawl-at/ ⇒ /risa:l-at/ and /ʔazuwz/ ⇒ /ʔazu:z/. However, in a footnote (p.132) Idrissi gave some examples which contradict his claim. In these examples the changing of /aw/ into the long vowel /a:/ cannot hold for /kawkab/, ‘planet’, and /billawr/, ‘crystal’. Although /aj/ is

attested to in Arabic in monosyllabic words, as in /tʔajr/, ‘bird’, it surfaces as a long vowel /e:/ in some Arabic dialects such as LA.

The representation of singular /qindi:l/ vs. its plural /qana:di:l/ is represented as follows:

(78)

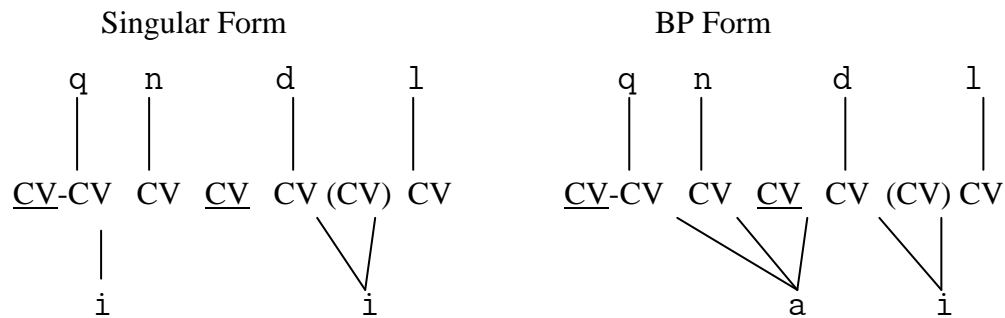

The parenthesized CVs hold for the lengthening of the vowel of the last syllables. Both the singular and the plural exhaust all five possible CVs of the base suggested for Arabic nouns.

The representation of singular /ʔandalib/ vs. its plural /ʔana:di:l/:

(79)

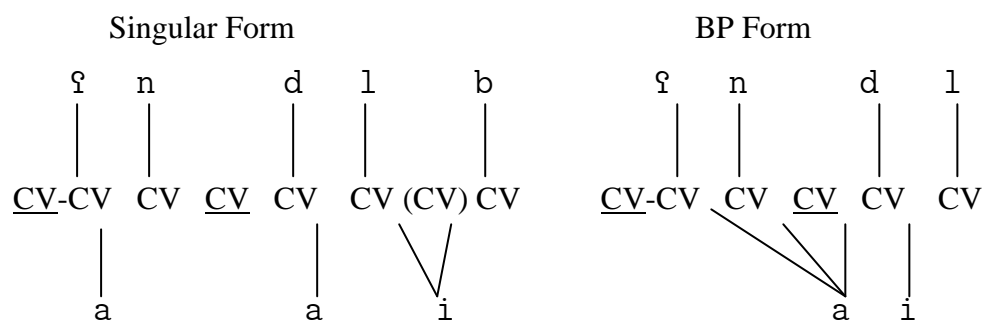

The singular displays an interesting structure. Recall that Idrissi assumed that Arabic nouns have a maximum of five CVs in the base structure for BP. The base of the singular shows five positions occupied by five consonants and there is another CV at the penultimate to host the lengthening of the vowel of the last syllable. Earlier, it was assumed that only singulars which lack a consonant on the penultimate CV select the

five-CVs base. The plural noun, however, shows only four CVs for the base. A whole CV slot is lost when the plural is formed: the long /i:/ is shortened to /i/ and the final consonant /b/ is truncated. This process of truncation is attested to in Arabic for similar nominal structures such as /farazdaq/, which is pluralized in two ways, /faraziq/ or /farazid/, in which one of the last two consonants is deleted. Idrissi justified this by saying that in order for “the five-CVs base to be selected, its penultimate CV must emerge associated with a vowel” (Idrissi, 1997, 133). This truncation can be related to the maximum consonant number constraint allowed in Arabic derivational morphology which is maximally four.

Idrissi assumed that regular plurals of Form I active participle nouns are derived from the corresponding singulars through apophony, as represented in the follow graph:

Derivation of the plural of active participle of the Form I noun /ka:fir/, ‘unbeliever’, ⇒ /kuffa:r/:

(80)

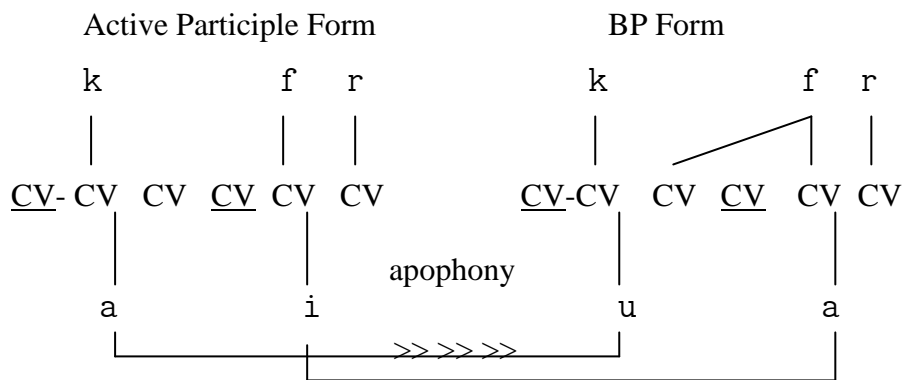

In this graph, apophony is assumed to generate the vowel melody in a mode of melodic overwriting. The linked lines show the change and overwriting of the vowel melody. This change in the vowel melody has a morphological function similar way a derivational site is identified. After melodic overwriting, the unlinked C-position is filled by the spreading of the second consonant root. Idrissi claimed that the CV position is realized through the spreading of an adjacent consonant. Otherwise, the realization of such CV positions is realized by /w/-epenthesis. The difference between



the template plural /CuCCaC/ and the template plural /CuCCa:C/, which exhibits a long vowel in the second syllable, is not morphologically distinguishable. Following McCarthy and Prince (1990b), he assumed that the first template is conditioned by a prosodic constraint which favours syllables to be parsed in terms of foot structure. Thus, the second syllable of the first template is not considered as a trochaic or an iambic foot. It is assumed that Arabic requires the prolonging of the vowel of the second syllable in the first template. To make it analyzable based on prosodic templates, a heavy syllable is formed as in /CuCCa:C/ instead of the light syllable in the second position in /CuCCaC/ (Idrissi, 1997, 134-135). Idrissi assumed that to satisfy a prosodic requirement, the second vowel of the result of apophony is linked by one mora at the phonological level, in other words, to give the long vowel /a:/. However, it must be noted that the derivation of the BP form from the active participle requires the identification of the internal derivational site, which is similar to the derivation of Form II verbs. In Idrissi's analysis, it was assumed that only apophony identifies the derivational sites of this pluralization of the active participle noun in the BP form. The spreading of the root consonant /f/ on the graph has no derivational significance based on Idrissi's analysis. Since he claimed that only apophony is at work here, the added CV which does not exist in the input singular has no reason to be in the output plural. It seems that the geminated consonant is triggered by the identification of an internal site, as can be seen in the graph below. Thus, this kind of pluralization can be assumed to go through two mechanisms: the first is identifying the suitable template and the second is apophony:

(81)

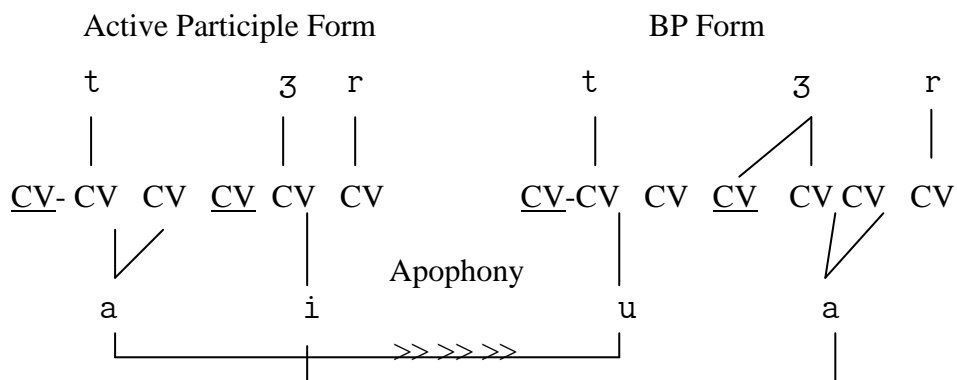

### 2.5.1.1 The Formation of Irregular BPs

According to Idrissi, what distinguishes irregular from regular BPs is that the former are not derived from their corresponding singular forms. In other words, the prosodic shape of the singular does not determine the plural template form. Though irregular plurals identify the internal and external derivational sites, as in regular plurals, many of their characteristics are unpredictable. These, for example, involve the unpredictability of vowel melody and also involve multi-selection plural forms for one singular form, as the follow examples illustrate:

(82)	Singular Form	BP Form
	/ʕamal/, ‘work’	/ʔaʕma:l/
	/ħabal/, ‘rope’	/ħiba:l/
	/ʔasad/, ‘lion’	/ʔusu:d/
	/ʔamal/, ‘hope’	/ʔama:l/
	/saʕi:d/, ‘happy’	/suʕada:ʔ/
	/ʕa:qil/, ‘wise’	/ʕuqala:ʔ/
	/ʔasi:r/, ‘prisoner’	/ʔusara:ʔ/ and also /ʔasra:ʔ/

Based on Idrissi’s argument, there is no easy way to derive the plurals from their corresponding singulars. In /ʕamal/ and /ħabal/, both singular noun forms have the same prosodic shape, although their corresponding derived plurals have different shapes. That is to say, the first output plural has an epenthetic glottal stop /ʔ/ as the onset of the first syllable, whereas the output of the second singular has a light syllable associated with the vowel melody /i/. Furthermore, the two nouns /ʔasad/ and /ʔamal/ have the same prosodic shape and their output derived plurals are both associated with long vowels but with different vowel quality. The first receives a long vowel /u:/ and the second a long vowel /a:/. The derived plurals of the verbal adjectives /saʕi:d/, /ʕa:qil/, and /ʔasi:r/ exhibit apophony as a way of deriving irregular plurals. In addition, as apophony denotes plurality, the suffix /a:ʔ/, which is attached to the output plural in apophony, seems to indicate the masculine

gender (Idrissi, 1997, 138). The lack of explanation in Idrissi's account of the varieties of prosodic shapes of BP forms is related, as explained in detail in chapter seven, to the failure to identify the morphological process of BP formation, and the failure to account for phonological constraints. For instance, short and long vowels could be morphologically supplied and have specific functions. Phonologically, the distribution of short vowels could be governed by syllabification requirements, supplied by default or vowel harmony and so on.

### 2.5.1.2 The Formation of SPs

The main difference between BP and the SP is that the derivational sites of the first plural are cited as internal infixation and/or prefixal affixation, whereas the second plural has its derivational site suffixed to the stem. The distinction can be drawn based on level ordering in lexical phonology (Kiparsky, 1982, 131-137). In this approach it is suggested that the interaction between phonology and morphology is level ordered in nature. That is to say, through lexical derivation and when a morphological operation takes place it will have a consequence on phonology in a way that will change the derived word internally or externally. For example, in the English language some morpheme affixes when attached to a stem word may cause a shift in stress which leads to an internal adjustment to the phonology of that word. However, some morpheme affixes do not have any effect on the internal stem word. In this sense of level ordering, it can be claimed that BP acts within the stem and takes precedence over SP formation, while SP acts outside the stem and has no effect on the phonology of the stem word (Ratcliffe, 1990). The masculine SP will involve the derivational process represented below. The last CV of the singular is attached to the CV plural suffix. The newly created syllable is identified by the spreading of the vowel, and the quality of the vowel depends on case marking:

(83)

$$\dots CV]_{\text{Singular}} \Rightarrow \dots CV + \underline{CV}_{\text{Plural}} + CV_{\text{Case}}$$

|  
u/i

Similarly, the derivational process of the feminine SP is achieved by creating a new syllable which is identified by the spreading of the vowel. The quality of the vowel is not affected by case marking since this operates after the feminine SP has been assigned:

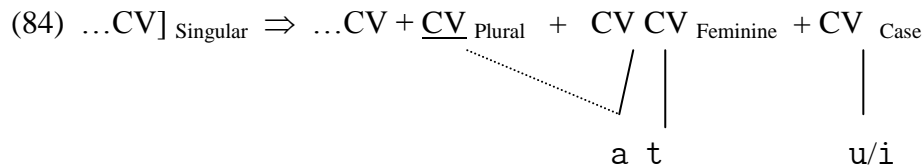

### 2.5.2 Roots and Sites

Kihm (2006) argued that it is not clear to which grammatical level the representations of Form I and Form II verbs in Guerssel & Lowenstamm’s model belongs. Though they are interface representations of phonology and lexicon (consonant melody), morphology (template) and syntax (vowel melody expresses inflection), Kihm presented a model where he married Guerssel & Lowenstamm’s model to the version of head-driven phrase structure grammar (HPSG) adapted for morphology. Lexical entries in HPSG consist of representations of signs and these signs are marked by features associated with the word-form. For example, a word-form may be associated with some of the following feature values: [head (syntactic category), number (singular, dual or plural), and gender (feminine, masculine or neutral). In the model Kihm presented, he proposed CA lexical entries with a feature of MORPH/R, where (R, means ‘root’ and receives sequences of consonants as its value, to be added to other features already provided by HPSG (Kihm, 2006, 75):

(85) [MORPH [R <CCC>]]

The sequence of the consonants is just for illustration and they can be filled at the phonological level by the exact number of the root consonants of the word-form. The root consonants of the word, /kaʔaba/ is represented as follows:

(86) [MORPH [R <C<sub>k</sub>C<sub>t</sub>C<sub>b</sub>>]]

Kihm assumed that all morphophonologically important features distributed by a lexical entry are ordered and given overt forms at one level. This structure is called ‘concrete lexical representations’ (CLRs), and ‘they constitute the interface between ordered features matrices of type ‘word’ and actual words’ (Kihm, 2006, 75). In a linear representation, for example, /katab/, ‘he wrote’, will have the following representation:

$$(87) \quad \langle W \langle \Sigma \langle R C_k C_t \{ V \langle A \rangle V_a \} C_b \rangle \rangle \rangle \Leftrightarrow /k.tab/ \text{ ‘/kataba/’ ‘he wrote’}$$

(Here, W: means ‘word’,  $\Sigma$ : means ‘stem’, and R: means ‘root’ consonants. The latter was originally  $\mathfrak{R}$  but this symbol is used in correspondence theory to refer to the correspondence relation between two related segments, or moras, etc. Thus, I suggest the use of R to account for the root. V<A> then refers to the quality of the vowel that follows the second consonant root and precedes the third consonant. This quality is usually referred to as the verbal inflectional Site VIS. The quality of this vowel, for example, is identified here as /a/).

/ka : taba/, ‘he corresponded/wrote’, will then have the following representation:

$$(88) \quad \langle W \langle \Sigma \langle R C_k \{ V \langle III \rangle C_A \} C_t C_b \rangle \rangle \rangle \Leftrightarrow /k.A.t.b/ \text{ ‘/ka : taba/’}$$

Here, the verbal derivational site VDS that follows the first consonant is identified by V<III> as an additional CV. /kattaba/, ‘to cause sb. to write’, will have the following representation:

$$(89) \quad \langle W \langle \Sigma \langle R C_k \{ V \langle II \rangle C_t \} C_b \rangle \rangle \rangle \Leftrightarrow /k.t.t.b/ \text{ ‘/kattaba/’}$$

## 2.5.2.1 Nominal Formation in the Root and Sites Approach

### 2.5.2.1.1 The Nominal Morphology of CA

In CA, nouns and adjectives are marked for the following features:

- (in)definiteness

Definiteness is achieved by the realization of a root external site. The definite marker /-l/ is prefixed to a word-form. /-l/ assimilates to a following coronal consonant, as in /l-ʒa : r/, ‘the-neighbour’,  $\Rightarrow$  /ʔaʒ-ʒa : r/.

- Case

Case marking is marked with three different vowels attached as suffixes which follow the last root consonant or the gender suffix and the preceding *tanwiin* which is an indefinite article suffix added to nouns in CA. Case marking is as follows; /-u/ expresses the nominative case; /-a/ expresses the accusative case; and /-i/ expresses the genitive case. There is a class of nominals known as ‘diptotes’ which express only two case suffixes: /-a/ for both accusative and genitive, and /-u/ expresses the nominative case.

- Gender

In CA, gender is spelled out by two types: unmarked masculine and marked feminine. In Kihm’s CLR’s model, gender has possible values of the feature N (CAT/N (Noun)) which must be present in CLR’s if V (verb) isn’t. Because the masculine is unmarked, the assumption is that masculine is unvalued for N (Kihm, 2006, 77). N is represented as follows:

$$(90) \quad \{ \langle W \langle \Sigma \langle R C_3 C_s C_r \rangle \rangle \rangle \{ N \} \} \Leftrightarrow /ʒ.s.r/ʒsr \text{ ‘bridge’}$$

In cases where N is identified as feminine then the value is presented as  $N_{\langle F \rangle}$ . The site identified by  $N_{\langle F \rangle}$  may be ordered to the right of the root. This is because the feminine marker value can be also represented by the feminine suffix marker /-t/. It must be noted that some feminine nouns do not have feminine suffix markers, however the value  $N_{\langle F \rangle}$  can represent the existence of the feminine marker in the CLR, as in the feminine noun /ʃams/, ‘sun’.

- Number

In the CLR model, singular is considered the unmarked value for number. In CA, there are two marked values for number: plural and dual. Plural is

unmarked in contrast with dual. The difference between singular and plural is the existence of the value NUM (i.e. number) sited in the CLR of the word-form. Dual is represented as NUM<sub><2></sub> in CLRs of dual word-form. Dual identifies an external root site and its ordered placement is on the right, as in /qalama:ni/ (nominative), ‘two pens’, and /qalamajni/ (accusative-genitive). SP exhibits a variation in suffixes when the plural is assigned for gender and case: -u:na<sub>nom</sub> and -i:na<sub>acc-gen</sub> for masculine nominals, and -a:tun<sub>nom</sub> and -a:tin<sub>acc-gen</sub> for feminine word-forms. The BP does not exhibit case marking nor is it marked for number. Thus, SP is the marked plural.

### 2.5.2.1.2 The Formation of BP from a Root and Site perspective

Kihm assumed four basic assumptions in the formation of BP:

- CA roots are set on a sequence of consonants. Although in verbs this is restricted to three or four consonants, in nominal word-forms there is no limit as long as no morphological operation applies to them. Moreover, all syllables are underlyingly open and take the form of a Cv sequence (here, Kihm assumes some phonological processes associated with the underlying structure. This is completely different from our view which sees the underlying structure as purely morphological processes. The phonological processes, including syllabification, take place only at the surface level).
- Vowels take the unmarked member in the segmental inventory. That is to say, they can occupy nucleus and onset positions. On the other hand, true consonants (obstruents) occur only in onset positions. Kihm assumed that there is no difference, for example, between the vowel /i/ and the glide /j/ because they are both alternate realizations of one form and they both have the same abstract segment which can be represented as /I/.

- The active consonantal root site is hosted between C<sub>2</sub> and C<sub>3</sub>. It was previously assumed that the VIS in verbs is identified by V, which is spelled out as one of the three available vowels that trigger aspectual marking. The same can be held for nominal words in NIS, where the same site is identified for number when activated.
- There is a morphological constraint that governs the length of the root in CA. The inflectional morphology of verbs in CA shows that it only deals with root consonants which are minimally three and maximally four. As suggested in Guerssel and Lowenstamm (1990), the template of the verb in CA consists of three or four root consonants and two derivational sites. One of the latter occupies an internal position in the template, while the second occupies an external position as a prefix. However, the length of the nominal word-forms is not restricted. The actual number of consonant roots in nominals can be minimally one and maximally seems to be six (Kihm, 2006, 80). BP is formed by the activation of the NIS identified by NUM and realized as an additional Cv syllable. This additional material, Cv for example, can build a quantitative correspondence relation between the BP form and its corresponding singular. These additional Cvs slots cannot both be identified and activated at the same time, but rather they are identified as either (C) or (v) at any one time. Thus, all the (C)s and (v)s slots that are created by site activation must be phonologically identified. There seems to be only one type of phonological material that is able to activate both C and v in the internal inflection site, and this is vowels/glides. In BP, the internal active site is identified by both vowels and glides and never by obstruents (Kihm, 2006, 81).

The BP template for trilateral or more nominals is C<sub>1</sub>v C<sub>2</sub>v C<sub>v</sub>G C<sub>3</sub>v (C<sub>4</sub>v). In this template, G (vowel/glide) identifies either C or v. The sequence of numbers shows the root consonants of trilateral and quadrilateral nominal forms. The BP form is not derived from its corresponding singular, but they both represent a parallel representation of the root (Kihm, 2006, 81). In other words, there are two factors that govern the diversity of the actual forms of BP: the first is the quality of G as /A/, /U/, or /I/; the second is the identification of C or v.



It must be noted that all the Cvs in the general template of BP represent open syllables in the underlying structure; however,  $Cv_G$  needs some explanation. Kihm assumed that  $Cv_G$  is also an open syllable, but the G is not a morpheme but rather the exponent of the existence of the feature NUM which identifies the NIS in the CLR. The value feature of G is actually the value feature of NUM. This feature value is represented in the available C and it surfaces either as /aGa/, /iGi/ or /uGu/. Since CA deletes glides when they occur between two short vowels, the deletion of the glide creates long vowels which appear respectively as /a: /, /i: / and /u: /. Also /aGu/ and /iGu/ show up as /a: / and /i: / respectively (Fleisch, 1961, 122ff; Gadalla, 2000, 22ff cited in Kihm, 2006, 82; also see section 4.4.2 for more detail).

### 2.5.2.1.3 The Formation of BP based on Root and Site

The example below shows the singular noun /kaɫb/, ‘dog’. The empty curly brackets are the active NIS site to host NUM. The vowels are not shown because every C is assumed to be followed by v. Since this site is not activated, the phonology assigns a value to the first v position resulting in /kaɫb/, which shows up as a singular by default:

$$(91) \quad \{ \langle w \langle \Sigma \langle R \ C_k C_1 \{ \ } C_b \rangle \rangle \rangle \{ N \} \}$$

In the case where two Vs slots exist in the template, such as  $CvCvC$ , then the second vowel is given a value by the phonology as in /raʒul/, ‘man’, for example. These vowels do not have morphological implications and appear to be random (Kihm, 2006:82). However, if the NUM is activated with a phonological effect in the CLR, it will give the structure below:

$$(92) \quad \{ \langle w \langle \Sigma \langle R \ C_k C_1 \{ NUM \ C_A \} C_b \rangle \rangle \rangle \{ N \} \} \Leftrightarrow /k.l.A. b/ /kila:b/, ‘dogs’$$

Biconsonantal nouns in CA identify the NIS after  $C_2$ . Although these nouns in the singular lack a third consonant, when the BP is formed it supplies the third consonant which is realized in this case as a glottal stop /ʔ/:

- (93)  $\{ \langle_{W \langle_{\Sigma \langle_{R C_d C_m \{ \} \rangle \rangle} \{ N \} \} \Leftrightarrow /dam/, \text{'blood'}$   
 $\{ \langle_{W \langle_{\Sigma \langle_{R C_d C_m \{ \text{NUM } C_A \} C \rangle \rangle} \{ N \} \} \Leftrightarrow /d.m.A. \text{?} / / \text{dima:} \text{?} /, \text{'blood' (plural)}$

Again, an epenthetic /i/ is inserted after the first C by the phonology. The BP templates /CiCa:C/ and /CuCu:C/ have the same prosodic structure and both identify C in the NIS by vowel/glides identification, but with one main difference. This difference is the quality of the vowel/glides that identifies C. In the former it is /A/ which is realized as /a: /, and in the latter it is /U/ which is realized as /u: /.

The quadrilateral templates /CaCa: CiC/ and /CaCa: Ci:C/ as plurals of the quadrilateral singular forms /CuCCuC/ and /CiCCa:C/ both identify the C in the NIS. However, it seems that the length of the last syllables in both singulars is transferred into the corresponding BP plurals, as was assumed in the templatic morphology approach (Hammond, 1988; McCarthy and Prince, 1990b). Consider the following example:

(94)	Singular Form	BP Form
	/ʒundub/, 'locust'	/ʒana:dib/
	/mifta:ħ/, 'key'	/mafa:ti:ħ/

Kihm claimed that the vowel length correspondence of quadrilateral BPs can be analyzed in a root-and-site analysis. First of all, he claimed that most words that exhibit this vowel length are complex quadrilaterals formed through derivation, especially by the prefix /-m/ attached to the root. On the other hand, it seems that simple quadrilaterals without derivation are limited. These simple and unanalysable words may be items which have forms similar to /ʒundub/, 'locust', /sikki:n/, 'knife', or /qindi:l/, 'lamp'; also other forms suffixed with /a:n/ as in /ʃajt<sup>ʕ</sup>a:n/, 'Satan', /sult<sup>ʕ</sup>a:n/, 'sultan'; or nouns of instruments which have the template /miCCa:C/ such as /minʃa:r/, 'saw', /mi:za:n/, 'scale'; or VNs which have the template /taCCi:C/, as in /tas<sup>ʕ</sup>wi:r/, 'picturing'.

Although the nouns of instruments have the prefix /-m/ attached to the root, when forming PB /-m/ it is considered as C<sub>1</sub>. For example, there is no difference between the simple quadrilateral noun /ʒundub/ and the complex derived quadrilateral /minʃa:r/, since both form BP by inserting /a:/ after C<sub>2</sub> without any reference to the true root consonant.

The quantity transfer claimed by Hammond (1988), McCarthy and Prince (1990b) and McCarthy (1997) cannot hold for biconsonantal nouns. In the formation of BP from a correspondent biconsonantal singular form, an extra consonantal root is inserted to repair the biconsonantal nouns when a BP form is derived from them, for example in /dam/ ⇒ /dima:ʔ/. However, it must be noted that Kihm assumed that both the singular and the BP forms are derived from the root. He claimed that /maʒa:hir/, ‘microscopes’, for instance, is a quadrilateral formatted root derived from the stem <<sub>Σ</sub> m ʒ{NUM C<sub>A</sub>} h r>, while its corresponding singular /miʒhar/, ‘a microscope’ is a trilateral basic root noun which is derived by prefixing /-m/ to the root <<sub>R</sub> ʒ h r> which itself assumed to be derived from the perfective verb /ʒahara/, ‘it was brought to light’)

Kihm also assumed that the low glide which shows up as /a:/ in the noun singular /miʔta:ħ/, ‘key’, is part of a long variant of the derivational template for nouns of instruments. The CLR of /miʔta:ħ/ is as follows:

$$(95) \quad \{ \langle \omega \langle \Sigma \rangle m \langle R \rangle C_f C_t C_A C_h \rangle \rangle \{ N \} \} \Leftrightarrow /m.f.t. A.ħ. / (A = a:) / miʔta:ħ/$$

Thus, Kihm (2006, 84) argued that the quantity of the last syllable of the singular /miʔta:ħ/ is not transferred into the correspondence BP /mafati:ħ/, but rather the derivational glide in the singular /A/ which shows up as /a:/ and is preserved in the BP form. In other words, the active derivational site that is associated with nouns of instruments is still active in the BP form. So, /miʔta:ħ/ is assumed to have the formatted root built in a template of five consonants <<sub>R</sub> C<sub>m</sub>C<sub>f</sub>C<sub>t</sub> C<sub>A</sub> C<sub>h</sub>>, but CA inflection morphology does not allow more than four consonants or less than three

consonants in BP. Any roots which extend to four consonants long are shortened to fulfil the number of root consonants constraint. For example /ʕankabu:t/, ‘spider’, has the formatted root built in 6 consonants  $\langle {}_R C_{\text{ʕ}}C_nC_kC_bC_uC_t \rangle$ , but when the BP is formed the formatted root is brought down to  $\langle {}_R C_{\text{ʕ}}C_nC_kC_b \rangle$  (here Kihm did not count the C that activates the NIS in BP). However, /mifta:ħ/, which has the formatted root built in five consonants  $\langle {}_R C_mC_fC_t C_A C_{\text{ħ}} \rangle$  is problematic in the derivation of the BP because the output BP formatted root must not exceed four consonants. So, the truncated segments in BP do not vanish completely but leave a trace behind (Kihm, 2006, 84). Kihm assumed that the mechanism that works for the singular noun /safarʒal/, ‘quince’ $\Rightarrow$  its BP form /safa:riʒ/ can also explain /mifta:ħ/ $\Rightarrow$  /mafa:ti:ħ/. The CLR of /safa:riʒ/ is as follows:

$$(96) \quad \{ \langle {}_W \langle {}_{\Sigma} \langle {}_R C_s C_f \{ \text{NUM } C_A \} C_r C_3 C_{(1)} \rangle \rangle \rangle \{ N \} \} \Leftrightarrow /s.f. A.r.ʒ //safa:riʒ/$$

The last root consonant /l/ is muted, and the second epenthetic short vowel /i/ is linked to the v position after C<sub>3</sub>. This epenthetic vowel is in the underlying structure represented as /I/, and when it is linked to the v after C<sub>3</sub> it is realized as a short /i/. Similarly, Kihm claimed that /mafa:ti:ħ/ exhibits the same process. The CLR of /mafa:ti:ħ/ is as follows:

$$(97) \quad \{ \langle {}_W \langle {}_{\Sigma} \langle {}_R C_m C_f \{ \text{NUM } C_A \} C_t C_{(A)} C_{\text{ħ}} \rangle \rangle \rangle \{ N \} \} \Leftrightarrow /m.f. A. t. C. \text{ħ.} //mafa:ti:ħ/$$

C<sub>3</sub> here is /t/, followed by three slots to which may /I/ link to: the v slot after C<sub>3</sub> /t/, the devalued C itself, and the v slot following it (Kihm, 2006, 85). It makes no difference whether /I/ identifies all three or only C, the outcome is the same where it surfaces as a long vowel /i:/ and is no longer counted as a consonant. Thus, the BP form now satisfies the maximum of a four consonants formatted root. Kihm refused the idea of vowel length transfer. The observed vowel length, he argued, is the consequence of glide surfacing. He claimed that the long /a:/ in /mifta:ħ/ and the long /i:/ in /mafa:ti:ħ/ are underlying glides that have a morphological function. The glides extend the roots in both words and they make them overlong. Thus, due to

the constraint that governs the number of consonant roots, pruning becomes a necessary mechanism to shorten this overlong form. Kihm defined pruning as ‘an operation which suppresses the value, but keeps the attribute, that is the C position’ (Kihm, 2006, 85). Then, lengthening of the epenthetic vowel after C<sub>3</sub> in the BP form follows. Even though Kihm denied vowel transfer, he is in other words suggesting glide transfer.

He went on to claim that the glide is able to identify the site’s V position in the CLR trochaic patterns /CuCuC/ and /aCCuC/ (in Wright’s account they are BP patterns III and XIII respectively). The CLR for /kutub/, ‘books’, of the singular /kita:b/, is given as follows:

$$(98) \quad \{ \langle {}_w \langle \Sigma \rangle {}_R C_k C_t \{ {}_{NUM} C^v U \} C_b \rangle \rangle \{ {}_N \} \} \Leftrightarrow /k.tub/ /kutub/$$

The v slot after C<sub>2</sub> /t/ is filled with v<sub>U</sub> ⇔ /u/ at the spell out. C in the NIS stays unvalued. This results in the structure /kʔub/, then vowel epenthesis takes place after C<sub>1</sub> and the vowel quality of the epenthesis is governed by vowel harmony resulting in the final structure /kutub/.

There are nouns in CA where it is traditionally assumed that they form their BP by the addition of /a:n/, as in /ba:b/, ‘door’ ⇒ /bi:ba:n/ (also /ʔabwa:b/), /waral/, a ‘kind of lizard’ ⇒ /wirla:n/. The length of the vowel (/a:/ and /i:/ in /ba:b/ and /bi:ba:n/) is due to the existence of a glide. Thus, the roots of /ba:b/ can be presented as follows:

$$(99) \quad \langle {}_R C_b C_A C_b \rangle$$

Because glides in CA are weak and tend to appear as long vowels, the C slot is occupied by the glide /A/ in the underlying structure. At the surface level, the position of the glide is filled by the epenthetic /I/ which is represented by the long vowel /i:/ in the BP form. This long vowel, which links the epenthetic /I/ to the devalued C position, does not count as a consonant. Kihm assumed that the /a:n/ attached to the

BP form is *tanwiin*. He assumed that the function of *tanwiin* here may be to make sure that the NIS must not only follow C<sub>2</sub>, but must also be internal to the formatted root:

$$(100) \quad \{ \langle w \langle \Sigma \rangle \langle R \rangle C_b C_{(A)} C_b \{ \text{NUM CA} \} C_n \rangle \rangle \{ N \} \} \Leftrightarrow /b.C.b.A. n/ /bi:ba:n/$$

On the other hand, in /waral/  $\Rightarrow$  /wirla:n/ he assumed that the BP form of C<sub>2</sub> /r/ it is transparent to root consonant counting where it is already three consonants and the fourth is the *tanwiin*). However, the transparency of BP formation does not imply invisibility to phonological interpretation, since the transparent consonant remains valued (Kihm, 2006, 86):

$$(101) \quad \{ \langle w \langle \Sigma \rangle \langle R \rangle C_w C_r C_1 \{ \text{NUM CA} \} C_n \rangle \rangle \{ N \} \} \Leftrightarrow /w.r.l.A.n/ /wirla:n/$$

This *tanwiin* assumption is not convincing, because most CA nouns are subject to *tanwiin* when they refer to indefiniteness. Consider the following examples:

(102)	Singular Form	Singular Template	BP Form
	/wa:di:/ ‘valley’	CvvCvv	/widja:n/
	/na:r/ ‘fire’	CvvC	/ni:ra:n/

Both singular words exhibit long vowels in the first syllable. In /wa:di:/ the root consonants are /w/, /d/, and /j/ which surface as /i:/, while in /na:r/ they are / (n/, /a:/ which are underlyingly /w/, and /r/. On the other hand, both BP words have similar templates. The first syllables of the two BP words have heavy syllables. The long /a:/ in the second two syllables of the BP words is the BP morpheme. In /wa:di:/, the long /a:/ in the singular has been lost in pluralization, and also the long /i:/ or /ij/ of the singular is shown as /j/ in the plural and it creates a new syllable to host the BP morpheme. The long /a:/ in /na:r/ is not shown as /w/ but rather as the long vowel /i:/. The claim is that the third root consonants in both words have created and are headed by new syllables in order to host the BP morpheme /a:/. This creates open syllables in both BP words /Cvv/, which is not

allowed in CA. Then, the epenthetic consonant /n/ is inserted to create closed syllables in both BP words. The existence of the epenthetic /n/ is widespread in CA, and for example is shown as a suffix in masculine SP, dual, the adjective /CaCCa:n/).

## 2.6 Prosodic Circumscription

The basic idea of circumscription is to restrict a prosodic part of a stem from left or right edge in order to apply morphological operations (McCarthy and Prince, 1990b).

There are two types of circumscription:

- In positive circumscription, the kernel, ‘first two moras’, is targeted.
- In negative circumscription, the residue, of ‘the remaining unparsed constituents in positive circumscription’, is targeted.

### 2.6.1 Positive Prosodic Circumscription

McCarthy and Prince proposed that the mechanism of forming BP is by parsing out the initial two moras, which are considered to represent the minimal prosodic requirements of the word which are interpreted in the circumscription mechanism as the base, and mapping the contents of the minimal word onto an iambic foot template (CvCvv). In other words, this function of prosodic circumscription tracks the first two moras (man) from the singular noun (mandi:l), and maps the iambic template (CvCvv) to (mana:). This results in the iambic foot (mana:), then the remaining (residue) of the singular noun, (di:l), is restored and attached to the iambic foot. The vowel melody is changed and the length of the last vowel is transferred to the plural template, as illustrated in the following example:

(103)	Input	mindi:l
	Circumscribe trochee at left edge (first two moras)	(man)di:l
	Parse onto iambic template	mana:

Restore residue and change vowel melody	mana:di:l
Output	[mana:di:l]

The prosodic measure that accounts for mapping the iambic template to the singular noun is  $\phi(W_{\min} = F_{QT}, L)$ , where  $F_{QT}$  represents a quantitative or Moraic trochee foot and  $FI$  is an iambic foot. This is the part of the function that parses the kernel, as in /tan/ of the BP word /tana:ni:n/ represented below:

(104)       $t\ a\ n = W_{\min}$

$F_I[\sigma [t\ a\ \mu]] [\sigma [n\ a:\ \mu\ \mu]] = \text{mapping iambic template}$

$CvCv = t\ a\ n\ a:$

From the vowel melody, it seems as if there is a spreading of /a/; however, there is no direct evidence to confirm this (McCarthy and Prince, 1990b, 247). Consonant mapping directly occupies the syllable onsets, which are the obligatory positions of consonants. This mapping also reveals that spreading is not automatic ((Pulleyblank, 1986 cited in McCarthy and Prince, 1990b, 247)). Singulars with a medial geminate present an interesting relationship to the  $\phi$ -parse, as represented in the following table:

(105)

B. Singular	B: $\phi$	B/ $\phi$	Plural	Diminutive	Gloss
tinni:n	tin	ni:n	tana:ni:n	tunajni:n	'dragon'

The morphological process targets the base B /tinni:n/, the kernel B: $\phi$  /tin/, and the residue B/ $\phi$  /ni:n/. The doubly associated consonant /n/ is both inside and outside the domain of template mapping. When the kernel /tin/ is mapped to the iambic template /CvCvv/, /n/ occupies the onset of the heavy syllable. The residue /ni:n/ remains unchanged and unaffected. The BP gives an interesting account for geminate integrity. This proposes that geminate consonants cannot be divided by rules of epenthesis (McCarthy and Prince, 1990b, 247-249), but rather by rules of segment spreading constrained by obligatory contour principles.



Extrametricity is widely established in metrical phonology. It is claimed (Hayes, 1980, 1982) that in each and every underlying phonological segment, forming morphemes have to occupy a position within the syllable. In some studies on English stress, it has been noticed that some underlying segments do not have any impact on the assignment of the stress on the syllable when they surface. These segments are considered as extrametrical. It has also been claimed that it is not only segments that can be extrametrical at an edge but also elements such as a mora, syllable or foot (Hayes,1982; Harris,1983). McCarthy and Prince (1990b) argued that extrametricality is at work in infixational morphology, where prefixes and suffixes which stand one unit from an edge are turned into infixes (McCarthy and Prince,1986). The main idea of the prosodic circumscription mechanism is based on extrametricality. The phonological or morphological circumscription operation works on the base form as follows:

- (106)         $\phi(C,E)$         (C (Constituent), E (Edge))  
                   $\phi$  (Phonological or morphological function)

When this phonological or morphological function operates on a base, it will choose the part of the base which is characterized by the extrametricality constraint (McCarthy and Prince,1990b,225). The function will return the designated constituent (C) that sits at the edge (E) of the base. This function of a base is rewritten as  $base:\phi$  (C, E), or  $B:\phi$  for short. This function effects the base and splits it into two parts: one is  $B:\phi$ , the part that is determined by the constraint (C,E); the other is the residue (the remainder left unparsed). This residue is the part of (B) outside  $B:\phi$  which is rewritten as  $B/\phi$ . In the prosodic circumscription of the base, the prosodic condition always selects the minimal word of the language which turns out to be the foot. The minimal expansion of the category word ( $W_{min}$ ) is a single foot. The positive prosodic specification of the base to which a rule applies is determined by the follow constraint:

- (107)        ‘Positive prosodic circumscription of a base may only appeal to the category Minimal Word. That is, in  $B:\phi$  (C, E),  $C=W_{min}$ ’. (McCarthy and Prince,1990b)

Positive prosodic circumscription occurs when the circumscribed constituent, that is the kernel or the B:ϕ portion, is targeted. Furthermore, the nature of the minimal word category is determined by the size of the foot. The minimum size of an unmarked stressed foot is two moras.

Early work on CV-theory specified two layers of association. The first is to map a word to a templatic layer; the second is to overwrite the vocalism of the word to the vocalism of the plural form. Melodic overwriting is essential to define the vocalism of Arabic iambic plurals. The circumscribed portion of the minimal word that is parsed to the iambic template normally receives one of various different possible vocalisms, but the residue does not. In the plural, the vocalism /a-i/ is introduced and is subject to a rule of the spreading of the /a/ across the template. The melody of the residue is assigned by overwriting /i/. This overwriting preserves the same length of the vowel, as in [ʒundub >> ʒana:dib, sult<sup>ʔ</sup>a:n>> sala:t<sup>ʔ</sup>i:n]. However, if the residue does not contain a vowel, then /i/ is deleted by stray erasure (McCarthy and Prince, 1990b,246).

Consonant spreading to occupy empty positions is the default only at the earliest stage of the morphology. The shapes and verbal derivation of lexical nouns are formed at that stage. However, at a later stage of the morphology, epenthetic consonants are introduced to occupy any empty onset: /w/ is introduced at level I where BP is formed; /ʔ/ is inserted postlexically (McCarthy and Prince, 1990b, 247). In the example below, the W<sub>min</sub> domain contains inadequate consonants to fill the two obligatory onset positions of the iambic template:

(108)

Singular	B:ϕ	B/ϕ	Plural	Gloss
xɑ:tam	xɑ:	tam	xɑwɑ:tɪm	'signet-ring'

When B:ϕ = /xɑ:/ is mapped from left-to-right to the iambic foot B:ϕ = xɑwɑ:, /w/ is supplied because the second onset of the iambic foot is empty. Thus, the rule accounts for the consonantal default /w/ is ∅ → w, when required by good syllabic formation.

B:ϕ in many forms seems to represent the first syllable. However, in the example below, B:ϕ = CvCv is the first syllable and a part of the second. The residue B/ϕ = vC is not in the base:

(109)

Singular	B:ϕ	B/ϕ	Plural	Gloss
saħa:b-at	saħa	ab	saħa:ʔib	‘cloud’

The morphological process in the example reveals that ϕ seeks moras and not syllables because  $W_{\min}$  in Arabic is bimoraic. The residue B/ϕ vC can be syllabified by the usual rules that derive syllabic representation from moraic structures. The one-and-a-half syllable /ab/ is treated as  $W_{\min} = \mu \mu$ . Subsequently, the default consonant rule is introduced to fill the empty onset; saħa:wib is the outcome of the insertion of the epenthetic /w/. Glide realization rules motivate the epenthetic consonant to surface as a glottal stop /ʔ/ in /saħa:ʔib/ (Brame, 1970, 244).

## 2.6.2 Negative Prosodic Circumscription

Although the PPC analysis succeeded in predicting some iambic BP forms, it failed to account for many forms where they are prosodically impossible according to the analysis proposed by McCarthy and Prince (Al-Suhaibani, 2004, 322). Al-Suhaibani lists some areas where PPC fails to account for BP formation:

In the follow examples, McCarthy and Prince’s incorrect analysis predicts trisyllabic iambic BP forms in the first two examples and a disyllabic form in the third:

(110)	Singular	BP
	s <sup>ʕ</sup> α:ħib, ‘friend’	*s <sup>ʕ</sup> αwα:ħib/ʔas <sup>ʕ</sup> ħα:b
	ħafi:d, ‘grandchild’	*ħafa:ʔid/ʔaħfa:d
	t <sup>ʕ</sup> αbʕ, ‘habit’	*t <sup>ʕ</sup> ubu:ʕ/t <sup>ʕ</sup> αbα:ʔiʕ

In  $s^{\text{ʕ}}\alpha:\text{ħib}$  an epenthetic /w/ is inserted to fill the empty  $C_2$  of the template  $Cv\text{wv}vCvC$ . Similarly, in  $\text{ħafi}:\text{d}$  the only difference is in the placement of the epenthetic consonant. In  $t^{\text{ʕ}}\alpha\text{b}\text{ʕ}$ , because the first two moras are targeted in PPC, the output plural incorrectly creates a disyllabic iambic plural.

Identifying the first two moras in the kernel is problematic. Because PPC targets the kernel and specifically the first two moras, it ignores the original prosodic structure of the singular stem. In  $/\text{ħafi}:\text{d}/$  it is an iambic form, when this form is parsed to an iambic plural template, it parses out an initial trochaic foot where the final syllable is split into two parts,  $\text{ħafi}:/\text{d}$ .

Al-Suhaibani argued that the iambic plural formation is not constrained by the operation of PPC but rather by the operation of NPC (Al-Suhaibani, 2004, 324). In NPC, the prosodic constituents that are subject to NPC are grouped into three categories based on the examples below from Al-Suhaibani (2004) which represent data from the Najdi Dialect spoken in the Arabian Peninsula and CA. The phonetic transcription is provided by the present researcher.

Negative circumscription of the rightmost consonant

(111)	Singular	BP
	/naf $s$ /, ‘soul’	/nufu: $s$ /
	/ʔasad/, ‘lion’	/ʔusu: $d$ /
	/ħafi: $d$ /, ‘grandchild’	/ʔaħfa: $d$ /
	/s $^{\text{ʕ}}$ α:ħib/, ‘companion’	/ʔas $^{\text{ʕ}}$ ħa: $b$ /
	/rα:ħib/, ‘monk’	/raħa: $bi:n$ /
	/t $^{\text{ʕ}}$ α:wu: $s$ /, ‘peacock’	/ʔat $^{\text{ʕ}}$ wa: $s$ /
	/ʃarri: $r$ /, ‘evil person’	/ʔaʃra: $r$ /
	/ʃa: $b$ /, ‘young person’	/ʃaba: $b$ /
	/ħmα: $r$ /, ‘donkey’	/ħami: $r$ /

When the rightmost consonant is isolated by the operation  $\Phi(\text{CONSONANT}, \text{RIGHT})$ , the residue of the singular stem is parsed onto the iambic plural template CvCvv. For example, in /nafɤ/, the last consonant /ɤ/ is targeted and isolated, and then the residue /naf/ is parsed into CvCvv yielding /nafɑ:/. Subsequently the circumscribed constituent /ɤ/ is restored resulting in /nafɑ:ɤ/. Finally changes are made to the vocalic melody resulting in the surface form /nufu:ɤ/. However, in addition to this derivational process some minor rules are needed to account for some iambic plural forms. These rules include onset-filling rules, suffixations and metathesis (Al-Suhaibani, 2004, 325).

Interestingly, /rɑ:ħib/  $\Rightarrow$  /rɑħɑ:bi:n/ seems to have undergone a trisyllabic iambic plural pattern. However, the singular appears to undergo pluralisation twice. First, as predicted by  $\Phi(\text{CONSONANT}, \text{RIGHT})$ , by applying the iambic plural template CvCvv and then the sound masculine plural suffix CvvC. This kind of pluralisation, plural-of-the-plural, is common in CA where usually a sound feminine plural suffix -ɑ:t is attached to a singular form which has already undergone BP formation, as in: /ragul/  $\Rightarrow$  /riɜɑ:l/  $\Rightarrow$  /riɜɑ:la:t/ ‘man’.

#### Negative circumscription of the rightmost mora

(112)	Singular	BP
	/tʔɑbʔ/, ‘habit’	/tʔɑbɑ:jiʔ/
	/ʔiɜl/, ‘calf’	/ʔɑɜɑ:ji:l/
	/ʔamal/, ‘deed’	/ʔama:ji:l/
	/saħɑ:b-a/, ‘cloud’	/saħɑ:ʔib/
	/wɑ:qiʔ-a/, ‘incident’	/wɑqɑ:ʔiʔ/
	/sa:ʔid/, ‘master’	/sɑjɑ:di:d/
	/go:l/, ‘saying’	/ʔɑɜɑ:wi:l/
	/blu:z-a/, ‘blouse’	/balɑ:ji:z/
	/sabi/, ‘capture’	/sɑbɑ:ɜɑ/

Here, the isolated prosodic element is the rightmost mora which is identified by the operation  $\Phi(\mu, \text{RIGHT})$ . When the rightmost mora is identified, the residue of the singular stem is parsed onto an iambic plural template CvCvv. The contents of the circumscribed mora are mapped onto either monomoraic syllable ( $\sigma_\mu$ ) realized as CvC, or a bimoraic syllable ( $\sigma_{\mu\mu}$ ) realized as CvvC. The mapping onto monomoraic or bimoraic syllables accounts for the vowel length of the final syllable of the plural form. Then, changes of vocalic melody and the applying of some minor rules are made to shape the output of the plural form (Al-Suhaibani, 2004, 328-329). For example, in /saħaːb-a/ the -a, which marks the singulative, is always lost when the plural is derived. The rightmost mora (ab) is identified and circumscribed, resulting in /saħa/ + /ab/ and then the residue /saħa/ is mapped onto an iambic plural template CvCvv. Then the kernel is restored and the vocalic melody, where -a spreads to fill the vocalic slots of the iambic template and -i fills the vocalic slot of the final syllable, is changed giving /saħaːib/. However, the last syllable of /saħaːib/ lacks an onset. To fulfil the requirements of formation, an epenthetic glottal stop /ʔ/ is inserted to fill the empty onset. Al-Suhaibani suggested that, instead of restoring the kernel as it is, it can be mapped onto a monomoraic syllable ( $\sigma_\mu$ ) realized as CvC (Al-Suhaibani, 2004, 346).

#### Negative circumscription of the rightmost syllable

(113)	Singular	BP
	/ʔamar/, ‘command’	/ʔawaːmir/
	/taʔab/, ‘trouble’	/mataːʔib/
	/raʒil/, ‘man’	/raʒaːʒiːl/
	/ʒaːmuːs/, ‘buffalo’	/ʒawaːmiːs/
	/diːnaːr/, ‘currency unit’	/danaːniːr/
	/ʒundub/, ‘locust’	/ʒanaːdib/
	/sʔultʔaːn/, ‘sultan’	/sʔalaːtʔiːn/
	/fuqaːʔ-a/, ‘bubble’	/faqaːqiːʔ/
	/libaːs/, ‘clothing’	/malaːbis/

/xɑ:tɑm/, ‘signet-ring’	/xawɑ:tɪm/
/nɑ:tʕɪr/, ‘guard’	/nawɑ:tʕɪr/
/ʒrɑ:b/, ‘pouch’	/ʒawɑ:rɪb/
/sɑʕi/, ‘effort’	/masɑ:ʕi/

When the rightmost syllable is identified by the operation  $\Phi(\sigma, \text{RIGHT})$  and isolated, then the same derivational and mapping processes of the rightmost mora are applied. For example, with  $/ʒɑ:mu:s/ \Rightarrow /ʒawa:mi:s/$  and  $/ʒundub/ \Rightarrow /ʒana:dib/$ , in both cases of the singular stems the kernel, which is the rightmost syllable, is isolated by  $\Phi(\sigma, \text{RIGHT})$  resulting in  $ʒɑ:(mu:s)$  and  $ʒun(dub)$ . The residues are mapped onto the iambic plural template CvCv yielding  $/ʒawa:ɪ/$  (with epenthetic /w/) and  $/ʒana:ɪ/$ . Then, because they are different in length to that of the final syllable, the two kernels are mapped onto a bimoraic syllable ( $\sigma_{\mu\mu}$ ) is realized as CvC resulting in  $/ʒawa:mi:s/$  and a monomoraic syllable ( $\sigma_{\mu}$ ) realized as CvC resulting in  $/ʒana:dib/$  respectively.

Although the length of the final syllable of the singular stem is preserved in the plural stem, it seems that some examples show a lack of Output-Output correspondence as in  $/rɑʒɪl/ \Rightarrow /raʒa:ʒi:l/$ ,  $/libɑ:s/ \Rightarrow /mala:bɪs/$  as well as  $/nɑ:tʕɪr/ \Rightarrow /nawɑ:tʕɪr/$ . This is problematic, since in restoring the kernel in the singular stem it is identified as a monomoraic syllable which is mapped onto CvC. However, in the plural form the last syllable is lengthened and mapped onto CvC instead of the actual input CvC. In  $/rɑʒɪl/ \Rightarrow /raʒa:ʒi:l/$  there is a consonant geminate in the plural which is not supplied in the input. In  $/libɑ:s/ \Rightarrow /mala:bɪs/$  there is an obvious difference between the corresponding forms. That is, the plural is +m which does not exist in the singular. It could be that the actual input singular is  $/malbas/$  and not  $/libɑ:s/$ . Similarly, there is a lack of correspondence between the final syllable of the singular and that of the plural. Al-Suhaibani suggested that the kernel (last syllable) of the singular is mapped onto a specified syllable, which is CvC (Al-Suhaibani, 2004, 358). Al-Suhaibani claimed that NPC exhausts all the iambic plural

data he provided by identifying the smallest rightmost prosodic constituent (that is consonant segment) up the prosodic hierarchy to the rightmost syllable. Although the mechanism of mapping the iambic plural template CvCvv is the same as that proposed by McCarthy and Prince (1990a), the only difference is the direction of circumscription which is here right-to-left.

## **2.7 Faithfulness and Prosodic Circumscription**

Within the correspondence theory literature, it has been suggested that faithfulness constraints can capture the relationships between linguistic structures (McCarthy and Prince, 1995; McCarthy, 1997). Correspondence between an underlying structure of a form and its surface form involves many types of faithfulness, such as in features, segments, and prosody. Faithfulness constraints can be generalized to further account for many other types of linguistic relations. There is a very close output-output transderivational correspondence relation between the surface output of a base word and the surface form of its immediate morphological derivative (Benua, 1995, 1997).

McCarthy (1997) abandoned the devices of prosodic morphology such as, circumscription, templates, or reduplicative copying. Based on the implementation of prosodic faithfulness constraints and the interaction of prosodic-structure and alignment constraints of infixation via circumscription, he concluded that ‘there is no role for operational prosodic circumscription at all’ (McCarthy, 1997,2). He argued that an important subset of recognized circumscriptional systems can be better understood in terms of the satisfaction of high-ranking prosodic faithfulness constraints.

### **2.7.1 Prosodic Faithfulness**

Faithfulness constraints originate from correspondence theory (McCarthy and Prince, 1993a, 1995). The main idea of faithfulness in correspondence theory is defined as follows:



(114) *‘Given two related linguistic forms  $S_1$  and  $S_2$ , correspondence is a relation  $\mathcal{R}$  between any subset elements of  $S_1$  and  $S_2$ . Any element  $\alpha$  of  $S_1$  and any element  $\beta$  of  $S_2$  are correspondents of one another if  $\alpha \mathcal{R} \beta$ ’.*

(McCarthy and Prince, 1993a, 1995)

Each  $S_2$  candidate has the same or different correspondence relation with each  $S_1$  candidate.

Correspondence and faithfulness are closely related. Faithfulness preserves the elements standing in correspondence, while correspondence represents, at least, a relationship between segments. Correspondence between moras reveals the clearest case of correspondence between prosodic units. In the suggested prosodic circumscription mechanism for Arabic BP, correspondence relations are met by a moraic based analysis. Nevertheless, faithfulness to syllables and feet is represented by the edge or the head segments that make up those constituents (McCarthy, 1997, 8).

### **2.7.2 Prosodic Circumscription as Moraic Faithfulness**

The circumscriptional operation assumed for Arabic BP is  $\phi$  (Ft $\mu\mu$ , left). However, this moraic trochee (CvCv) foot is not normally found at the beginning of an Arabic noun stem. In addition, a light-heavy iambic (CvCvv) foot is found in many nouns (McCarthy, 1997). The parsing of such a CvCvv by the circumscriptional operation leads to a truncation of the foot which leaves the part (v) unparsed as in (d) in the following table:

(115)

	Singular	B:ϕ	B/ϕ	Plural	Gloss
a-	nafs	naf	s	nufu:s	‘soul’
	ʔasad	ʔasa	d	ʔusu:d	‘lion’
b-	ʒundub	ʒun	dub	ʒana:dib	‘locust’
	sult <sup>ʔ</sup> a:n	sul	t <sup>ʔ</sup> a:n	sala:t <sup>ʔ</sup> i:n	‘Sultan’
c-	xa:tam	xa:	tam	xawa:tim	‘signet-ring’
	ʒa:mu:s	ʒa:	mu:s	ʒawa:mi:s	‘buffalo’
d-	saħa:b-at	saħa	ab	saħa:ʔib	‘cloud’
	ʒazi:r-at	ʒazi	ir	ʒaza:ʔir	‘island’
e-	kutta:b	kut	ta:b	kata:ti:b	‘religious school’
	ʒilba:b	ʒil	ba:b	ʒala:bi:b	‘traditional dress’

The circumscriptional operation extracts B: ϕ then maps it onto the CvCvv iambic foot template. The residue B/ϕ is then attached and some adjustments are made in the vocalism. The descriptive results of applying this operational function lead to the following claims:

- Circumscription protects the B/ϕ portion from alteration by the plural template: reserving the final syllable in (115-b) ʒundub/ʒana:dib and sult<sup>ʔ</sup>a:n/sala:t<sup>ʔ</sup>i:n. The fragment /ir/ in (115-d) is also preserved by inserting an epenthetic onset.
- The distribution of epenthetic onsets in (115-c, 115-d) shows an abstract effect of circumscription. In (115-c) B: ϕ /xa:/ contains only one consonant, whereas, in (115-d) /saħa/ contains two consonants. Consequently in (115-c) the plural templatic portion /xawa:/ is supplied by epenthetic consonant /w/, and in (115-d) /saħa:/ B/ϕ /ab/ is preserved by inserting the onset /w/ realized in this structure as /ʔ/.
- Circumscription provides a principled account for explaining the conservation of the spreading of a root consonant as in (115-e), even swapping local spreading for a long distance (kutta:b/kata:ti:b).

These claims can also be translated into prosodic faithfulness constraints in OT. The prosodic faithfulness of preserving the weight of the final syllable can be attributed to the high ranking of MAX- $\mu$  and DEP- $\mu$ . Epenthetic consonant distribution and the conservation of consonant spreading are also attributed to faithfulness constraints, but here are attributed to autosegmental associations (McCarthy, 1997, 25).

McCarthy (1997) developed the operational circumscription adopted to account for BP into OT prosodic faithfulness constraints (see also Al-Aghbari, 2001, for an implementation of this approach with Omani Arabic). McCarthy argued that the relationship between the singular and its plural form is assumed to be a transderivational output-output (O-O) correspondence relationship. He noticed some generalisations for the formation of the BP when the circumscriptional operation takes place: the preservation of the weight of the final syllable is an effect of prosodic faithfulness; the position of the epenthetic consonants in /xawa:t<sub>im</sub>/ and /ʒaza:ʔir/; and the conservation of the spreading of consonants is a matter of autosegmental association faithfulness. Autosegmental association faithfulness is the effect of the preservation of segment-to-mora linkages. In other words, these faithfulness constraints are anti-spreading and anti-delinking. In his analysis, McCarthy assumed that both moras and segments stand in O-O correspondence relationships.

In the following examples, superscripted indices are used to account for mora-to-mora correspondence relations, subscripted indices are used to account for segment-to-segment correspondence relations and ( $\hat{\quad}$ ) shows shared Cv moras. The function of the indices is to represent the correspondence relations between the singular and the plural; they have no inherited order. The unsuperscripted mora in the BP form, which has no correspondent in the singular form and thus lacks O-O correspondence, appears at the end of the second syllable (McCarthy, 1997, 26):

Singular-Plural correspondence relations

(116)	Singular Form	BP Form
	/n <sub>1</sub> $\hat{a}$ <sup>1</sup> f <sub>3</sub> <sup>2</sup> s <sub>4</sub> /	/n <sub>1</sub> $\hat{u}$ <sup>1</sup> f <sub>3</sub> $\hat{u}$ <sup>2</sup> :s <sub>4</sub> /

$/\widehat{z}_1\widehat{u}^1n_3^2d_4\widehat{u}^3b_6/$	$/\widehat{z}_1\widehat{a}^1n_3\widehat{a}^2:d_4\widehat{i}^3b_6/$
$/s_1\widehat{u}^1l_3^2t_4\widehat{a}^3:n_6/$	$/s_1\widehat{a}^1l_3\widehat{a}^2:t_4\widehat{i}^3:n_6/$
$/x_1\widehat{a}^1:t_3\widehat{a}^3m_5/$	$/x_1\widehat{a}^1w\widehat{a}^2:t_3\widehat{i}^3m_5/$
$/\widehat{z}_1\widehat{a}^1:m_3\widehat{u}^3:s_5/$	$/\widehat{z}_1\widehat{a}^1w\widehat{a}^2:m_3\widehat{i}^3:s_5/$
$/\widehat{z}_1\widehat{a}^1z_3i^2:r_5(at)/$	$/\widehat{z}_1\widehat{a}^1z_3\widehat{a}^2:\widehat{r}i^3r_5/$

A set of constraints used to account for McCarthy's analysis are given below:

- Constraints demand complete correspondence or identity of corresponding elements:

MAX<sub>oo</sub> (seg): Every segment in output<sub>1</sub> has a correspondent in output<sub>2</sub>.

DEP<sub>oo</sub> (seg): Every segment in output<sub>2</sub> has a correspondent in output<sub>1</sub>.

- Constraints demand the conservation of autosegmental association:

NO-SPREAD<sub>oo</sub> ( $\mu$ , seg): Spreading of moras or segments is prohibited.

NO-DELINK<sub>oo</sub> ( $\mu$ , seg): Reassociation of moras or segments is prohibited.

The function of the constraint NO-SPREAD<sub>oo</sub> ( $\mu$ , seg) is to account for the fact that spreading is not normally an option for onset filling situations. The function of the constraint NO-DELINK<sub>oo</sub> ( $\mu$ , seg) is to maintain that the spreading in the singular is preserved in the plural.

- Constraints demand conservation of prosodic constituents:

MAX<sub>oo</sub> ( $\mu$ ): Every mora in output<sub>1</sub> has a correspondent in output<sub>2</sub>.

DEP<sub>oo</sub> ( $\mu$ ): Every mora in output<sub>2</sub> has a correspondent in output<sub>1</sub>.

Although McCarthy has not developed clear O-O correspondence relations between the singular and its plural, he has accounted for many O-O relations. The preservation of the final syllable is the consequence of mora faithfulness in singular-to-plural

mapping as in /sult<sup>2</sup>a:n/ where the plural is /sala:t<sup>2</sup>i:n/ and not \*/sala:t<sup>2</sup>in/, and for /ʒundub/ it is /ʒana:dib/ and not \*/ʒana:di:b/. The constraint MAX<sub>OO</sub> (μ) is ranked low in Arabic; this is because some materials lack correspondents in the O-O plural. The constraint DEP<sub>OO</sub> (μ) is violated by the added mora (affix) in the plural form. The distribution of epenthetic consonants in the plural is a matter of obedience to autosegmental association. The successful plural candidate for /x<sub>1</sub><sup>1</sup>a<sup>2</sup>:t<sub>3</sub><sup>3</sup>a<sup>3</sup>m<sub>5</sub>/ is /x<sub>1</sub><sup>1</sup>a<sup>1</sup>w<sup>2</sup>a<sup>2</sup>:t<sub>3</sub><sup>1</sup>i<sup>3</sup>m<sub>5</sub>/ and not \*/x<sub>1</sub><sup>1</sup>a<sup>1</sup>t<sub>3</sub><sup>1</sup>a<sup>2</sup>:w<sup>1</sup>i<sup>3</sup>m<sub>5</sub>/, since the latter failed candidate has undergone re-association. Also, for /ʒ<sub>1</sub><sup>1</sup>a<sup>1</sup>z<sub>3</sub><sup>1</sup>i<sup>2</sup>:<sup>3</sup>r<sub>5</sub>/, the candidate /ʒ<sub>1</sub><sup>1</sup>a<sup>1</sup>z<sub>3</sub><sup>1</sup>a<sup>2</sup>:ʔ<sup>1</sup>i<sup>3</sup>r<sub>5</sub>/ obeys the association of autosegmental elements, and the failing candidate /ʒ<sub>1</sub><sup>1</sup>a<sup>1</sup>ʔ<sup>1</sup>a<sup>2</sup>:z<sub>3</sub><sup>1</sup>i<sup>3</sup>r<sub>5</sub>/ fails to fulfil this association. The maintenance of autosegmental association is maintained by the constraint NO-DELINK<sub>OO</sub> (μ, seg) which militates against the re-association of moras and segments. Consonant spreading was also dealt with by McCarthy by introducing the constraint NO-SPREAD<sub>OO</sub> (μ, seg). Consonant spreading in the singular is respected in the plural form. Spreading is revealed when a single consonant occupies more than one syllabic node. This spreading is represented locally, as in /r<sub>1</sub><sup>1</sup>a<sup>1</sup>d<sub>3</sub><sup>2</sup>d<sub>3</sub>/ ‘reply’ ⇒ /r<sub>1</sub><sup>1</sup>u<sup>1</sup>d<sub>3</sub><sup>2</sup>u<sup>2</sup>:d<sub>3</sub>/, or as long-distance spreading as in /k<sub>1</sub><sup>1</sup>u<sup>1</sup>t<sub>3</sub><sup>2</sup>t<sub>3</sub><sup>1</sup>a<sup>3</sup>:<sup>4</sup>b<sub>5</sub>/ ⇒ /k<sub>1</sub><sup>1</sup>a<sup>1</sup>t<sub>3</sub><sup>1</sup>a<sup>2</sup>:t<sub>3</sub><sup>1</sup>i<sup>3</sup>:<sup>4</sup>b<sub>5</sub>/.

Segment correspondence is mapped from one root node in the singular to a corresponding root node in the plural, and thus /d/ and /t/ in the preceding singular examples stand in correspondence with /d/ and /t/ in their plural forms. Accordingly, the constraint that militates against spreading NO-SPREAD<sub>OO</sub> (μ, seg), ensures that consonant spreading in the singular is respected in the plural.

## 2.8 Gaps in Previous Studies of BP

Having introduced the main studies that have investigated the formation of BP, it is worth evaluating these studies and their findings in the light of a simple question ‘what is the underlying structure, or in other words the input, of a BP form?’ This question represents the starting point, we think, of the input for the morphological process of BP formation. All the previous mentioned studies of BP share something in common either directly or indirectly. In their methods of dealing with the formation of

BP, they suppose some structure of the singular form as the input for the output BP form. CA grammarians take all the candidates of a set of singular patterns as inputs and map them to a particular BP form. Although they account for some phonological and semantic processes and predict the association of some singular patterns to qualify for a specific BP form, their accounting of the derivation of BP remains descriptive and does not provide an analytical account which can reveal how morphology works in the derivation of BP.

The first analytical study was carried out by Levy (1971). Her study is a derivational morphophonological study in which she provided lists of major and minor phonological processes which are associated with the derivation of BP. These phonological processes are represented as transformational processes that shape the input singular forms in order to achieve the targeted final BP form. Minor phonological processes are shaped in a few rules in which the input singular form is processed by one rule at a time to achieve the BP form. On the other hand, major phonological processes involve many rules applied to the singular form one once until the well-structured BP form is achieved. As Levy herself noted, the phonological rules applied to similar singular patterns are sometimes unpredictable (Levy, 1971, 358).

In autosegmental studies (McCarthy, 1979, 1981; Abd-Rabbo, 1988; Hammond, 1988; Yip, 1988), the elements of the input are represented at three levels of abstract representation; vocalic, consonantal, and templatic. The template holds for the well-structured pattern of any derived morphological process. Abd-Rabbo (1988, 87) included other elements which he claimed have effects on the BP formation either by their existence or absence. These elements are considered to exist outside the stem singular in the grammatical categories of which the singular forms are identified either as a noun or an adjective and the assignment of gender. Studies which adopt autosegmental approach; although they try to provide general principles of BP formation, are restricted to some singular-plural mapping forms. What is interesting in the autosegmental approach is the identification of the components of the stem word in Arabic. However, these studies fail to recognize the internal morphological and phonological processes which take place within the stem word. As the present study will reveal, the consonantal root is the starting point in the derivation of BP and the

idea of mapping as well as the idea of the template are rejected in favour of identifying the internal active morphological sites. Furthermore, the variety of templates are seen in this study not at an abstract level of representation, but rather as well-formed structures shaped by the phonology of the language. Hammond (1988) was the first to observe that there are some materials transferred from the singular input to the BP. Actually, he only accounted for the transfer of the length of final long vowels. This research takes his observation further and claims that even the consonantal roots are transferred and some morphological processes associated with the singular input are also transferred to the output BP form. There is, however, another claim of the autosegmental approach which must be clarified. This claim concerns the state of short vowels in the BP, form which is dealt with by overwriting, spreading, and epenthesis processes. In fact, short vowels, as studies indirectly suggest, are not transferred from the singular input. Therefore we must ask what is the source of short vowels in a BP form? This source, we suggest, is supplied either by the morphology or the phonology. Either as morphologically or phonologically motivated, the syllabic structure of any derived word has to fulfil the good formation structure of the language. Thus, short vowels have to be positioned in such a way as to break any consonantal clusters which result from any derivational morphological process.

The pioneering work of Guerssel & Lowenstamm (1990), which was applied to BP formation by Idrissi (1997) and Kihm (2006), gives more insight and reveals how morphological processes work internally or externally on the base word. In this work, the derivational morphological processes are recognized when a host morphological active site is identified. There is no need to distinguish between concatenative and non-concatenative morphology. In Arabic, it seems that the morphology makes reference not only to sites external to the stem word, such as prefixation or suffixation, but rather it also makes reference to internal sites existing within the string of root consonants as infixation. Although these studies assume some patterns of templates represented in the underlying structure as a string of CV's (a string of light syllables) filled by root consonants in the C-position and by morphological or phonological vowels in V-position, the present study suggests that the underlying structure of a morphological process exhibiting infixation is represented as a string of root consonants plus any morphological components associated with the input word.

In other words, there is no need to assume a kind of template associated with a specific morphological process where the size of this template is determined by filling the positions of its consonants and vowels (see sections 3.2.3 and 3.3 for details). If a position is not identified, it is simply deleted. The idea of the template itself, whether it is fixed or not fixed, is challenged by the existence of active morphological sites. These active sites do not make reference to the edges of any part of the template, but to the root consonants as we will see with the morphological derivational processes of nouns and adjectives and the formation of BP. Thus, infixational morphological processes can be better understood by identifying the active morphological sites at work in a specific morphological process and not to mapping them onto some kind of template. This assumed template does not actually exist, but rather is the consequence of applying phonological processes to the underlying structure of a morphological form. These phonological processes are generally triggered by the requirements of well-formed syllable structure. Therefore, the diversity in the assumed templates is better related to preference of the prosodic structure in the language and not to the existence of an abstract level of representation where the template is identified as a property of the morphology. In addition, it is not only the morphology which makes reference to sites within the stem word, but also the semantics and the syntax. For example, doubling the second root consonants leads to intensifying the action of the derived form. Also, identifying the feminine suffix *-at* in some BP forms leads the noun or the adjective being identified as a collective form. As far as the syntax is concerned, the internal active site of the last syllable and/or the external active site on the right side of the stem word always hosts many syntactic properties. That is to say, morphological, semantical, and syntactic operations are triggered and hosted in active morphological sites. As soon as such morphological sites are activated, the underlying structure of the derived word is created. At the surface structure, the phonology repairs any ill-formed structure resulted from the morphological derivational process. Although our study is mainly a morphophonological study, we will encounter some morphological structures where the morphology interacts with semantics and syntax. In these interactions, identifying the active sites by more than one morpheme will lead either to restructuring the form or deleting one of these morphemes or restricting the choice of BP forms.



The other type of study which has influenced many researchers uses the approach of prosodic morphology (McCarthy and Prince, 1990a, 1990b). Here, the morphological processes are assumed to take effect in one circumscribed prosodic part of the stem word either left (positive) or right (negative). However, although this approach has been mainly applied to BP formation, it is restricted only to the most productive patterns which have an initial iambic foot in their BP forms. Moreover, this approach assumes some faithfulness correspondence relation between the stem word and the derived BP form. This faithfulness relation is preserved when some parts of the two forms are not subject to any kind of morphological processes. In other words, the claim here is that the derivational processes of the morphology are only restricted to a part of the stem word. This also means that the input for a morphological process is a part of the stem word where the morphological processes take place. Although the motivation for such studies is to argue for the minimal requirements of the prosodic word in Arabic, which is bimoraicity, it is difficult to explain using this approach the diversity of foot structures found in many derived forms. As mentioned earlier, the phonology of CA and LA prefers syllables to be parsed bimoraically or bisyllabically. Thus, bimoraicity or disyllabicity are properties of the phonology and not of the morphology. This phonological preference should be seen as a requirement of a well-formed structure in the language as a whole, which motivates the existence of this requirement in both the circumscribed part of the input and the iambic BP template of the BP form.

Assuming complete or partial prosodic correspondence (McCarthy, 1997; Al-Aghbari, 2001) between the stem word and its derived BP form cannot explain the absence or the existence of some prosodic structures in the derived forms. As shown later in this study (see sections 3.2.3 and 3.3), faithfulness between the two forms is motivated by the need to preserve the morphological properties of the input and not by the phonology alone. For example, the manifestation of the morpheme of the active participle /a:/ as /w/ in the derived form is the result of a morphophonological relation. The preservation of the length of the long vowel in the final syllable as in /ʔasʕfu:r/, ‘bird’,  $\Rightarrow$  /ʔasʕa:fi:r/, ‘birds’, is also the preservation of a morphological property. Correspondence relations between the two forms can only be represented as morphological relations that involve the root consonants plus any

morphological properties associated with the input form. This is the starting point of the derivational morphological process in achieving the targeted output derived form. In this way, because the aim is to derive a new word, the morphological morphemes of the output will be positioned within the underlying structure of its form plus the morphological morphemes associated with the input of the base form. If the morphological morphemes of the two forms clash, then the morphemes of the output will have priority over those of the input. This may consequently lead to the deletion of the morphological morphemes of the input. However, if they do not clash, then they can both survive as long as they are hosted in different active morphological sites. After satisfying the morphological requirements of derivation, then the phonology maintains the output as structurally well-formed. Thus, any existing superficial correspondence relation can be related either to the preservation of some morphological properties or the requirements to satisfy the prosodic preferences of the language. These prosodic preferences are always at work to modify any morphologically derived forms regardless of whether they are inputs or outputs.

As we have seen, all previous studies assume some kind of starting point to the derivational process of BP which could be considered as the input, though not all these studies explicitly discuss the state of the input in a morphologically derived process. Our claim, however, argues for the importance of identifying the input as the raw material for derivational morphology. By doing so, the morphological derivational process is better understood and the optimal well-formed derived form is justified based on its relation to the input. This simply means that morphology applies first before phonology.

## 2.9 Conclusion

This chapter has presented the main findings of each study considered. In some studies, there was a tendency to account for all the patterns associated with the formation of BP. Other studies restricted their investigation to a few productive patterns, motivated only by a phonological and not a morphophonological account. What all these studies lack is specifying the nature of the underlying structure of the derivational morphological process of BP. The idea of correspondence between the input singular and the output BP must be clearly identified, since there is no complete correspondence between them. Such correspondence must be morphologically motivated because phonological components do not stand in correspondence at all. In fact, the idea of active morphological sites reveals the actual derivational morphological process not only in BP but in all non-concatenative morphological processes in Arabic.

The following chapter introduces the framework of the thesis, which is OT. Its main aim is to structure an OT analysis so as to account for the derivational morphology of the non-concatenative nominal system of LA. It is argued that the actual state of the input represents the underlying structure for any morphological derivational process which involves infixational materials. Morphologically motivated infixation is a widespread process in the derivation of nouns, adjectives, and BP formation. The subsequent three chapters discuss this infixational process in LA (Sirt Dialect) in terms of the assumption that the state of the input represents a starting point in the derivational morphology which exhibits infixation or non-concatenative processes in general. It turns out that the account of the derivation of BP goes hand in hand with that of nouns and adjectives. Since BP forms are either nouns or adjectives, the derivation of nouns is presented first, followed by that of adjectives, and then an account of BP is given.

## **Chapter 3: An Optimality Theory Account of Non-concatenative Morphology**

This chapter briefly introduces the fundamental structure of OT and investigates some of the implications of correspondence theory in a morphophonological derivational environment. Also, the state of the input for the morphological derivational process of BP is examined in order to reveal the actual underlying form of this process. An account of and justification for the types of constraints which interact in order to determine the optimal candidate are also given. The theme of this chapter is to account for and prove that morphological processes take place first which give the underlying morphological structure for any derived word, and then phonological processes take place at the surface level to well-structure the underlying form.

### **3.1 Introduction to Optimality Theory**

In the terminology of early generative grammar (Chomsky, 1965; Chomsky and Halle, 1968) and its successive theories, the input (underlying form) of a linguistic object is conceived as the initial point of transformational or derivational rules. These rules apply one after another. That is to say, the input is subject to a series of operations, and the outcome of these operations gives the output or surface form. This output becomes the input of another rule and so on until the final output is achieved.

Conversely, OT (McCarthy and Prince, 1993a/b; Prince and Smolensky, 1993; Prince and Smolensky, 2004b) is a theory of language and grammar whose main implication is to compare the real output or surface structure to the input or underlying structure. OT abandons the rule-based approach and instead introduces a set of Constraints (CON) which interact in parallel in comparing a set of candidate output forms to the input. The constraints are ranked in a hierarchal order starting from the highest ranked constraint and ending in the lowest ranked. These constraints are violable in the sense

that the optimal output candidate must commit the fewest violations of the top ranked constraints. This hierarchy of constraints consists of a universal and language-specific set of constraints. Because of the violability of constraints, the output usually violates some of the lower-ranking constraints, and the optimal candidate is one which does not violate the higher ranked constraints. The basic structure of the evaluation process is explained as follows:

(117) Input → Generator (GEN) → Candidates → Evaluator (EVAL) → Output

The generator is a universal set, and its function is to construct candidate output forms and to specify a relationship between them and the input. Although in principle the input is unconstrained, the role of GEN is to generate logical candidate forms for the input. The evaluator serves to assess the candidates through a specific hierarchal ranking of active constraints. This ranking consists of language-specific as well as universal constraints. The basic mechanism of OT is illustrated below:

(118)

Input		→	Constraint <sub>1</sub> >>>	Constraint <sub>2</sub> >>>	Constraint <sub>(n)</sub>	→	Output
Candidate <sub>1</sub>							
Candidate <sub>2</sub>							
Candidate <sub>(n)</sub>							

The mechanism of the process starts when GEN receives an input and chooses the possible set of candidates. Then EVAL applies the ranking language particular and universal constraints. Candidates probably violate at least one ranking. A candidate that best avoids violating high-ranking constraints is optimal candidate. There are two basic types of constraints in OT: faithfulness and markedness constraints. Markedness constraints evaluate only the good formation of the output candidates, that is to say, that candidate forms are phonetically and phonologically well-formed. Faithfulness constraints evaluate the relationship and identity between the input and output, aiming at the preservation of information to maintain the faithfulness relations of the output to the input.

In OT, the interactions between constraints hold at the level of the output. As just mentioned, there are two sets of constraints that are at work in choosing the optimal candidate for the output. The first set is markedness constraints which fulfil the requirements of the good formation of output forms. That is to say, there are certain segmental and prosodic requirements that must be implemented. The second set of constraints concern faithfulness and evaluate the faithfulness of the output form to the input form. Faithfulness constraints require lexical identity between the input form and the output form. For example, LA forbids onset clusters at the surface level which are sometimes the result of deleting the unstressed short vowel in the syllable. In LA, the word /ki<sup>1</sup>ta:b/, ‘book’, surfaces as /ʔik<sup>1</sup>ta:b/. Based on the tableau below, four possible outputs are crosschecked with some active constraints. Let us first introduce the active constraints of LA at work:

ONSET: Syllables must have onsets (Prince and Smolensky, 1993).

\*COMPLEX: No complex syllable margins (Prince and Smolensky, 1993).

DEP-IO: Output segments must have input correspondents.

\*[Cv]<sub>σ</sub>: Open light syllables are prohibited.

The tableau in the OT literature is used to account for outputs and to crosscheck them with interactive constraints. Outputs take the left vertical position, while constraints take the top horizontal position. The constraints are ordered in a descending order starting from the highest ranked to the lowest ranked constraint. An asterisk (\*) shows a violation and the exclamation mark (!) shows a fatal violation committed by any candidate. The arrow (→) indicates the winning constraint. It must be noted that the order of the outputs in the tableau does not reflect or assume any logical sequence. The suggested ordering is put forward for the sake of simplicity and illustration. In fact, only the obvious possible candidates are suggested which maintain the logical correspondence relations between the input and any possible output. Thus, the suggested ordering of the outputs is motivated by two driving forces; the logical grammatical structure and the ordering of the interactive constraints. However, the hierarchy of constraints from high-ranked to lower-ranked implies that the last listed output is the least likely to surface, even though it is sometimes faithful to the input. The first listed output marked with the arrow is the optimal candidate since it does not

violate the top-ranked constraints. An example of the interaction of constraints to choose the optimal candidate is given below:

(119)

Input: /ki.ta:b/	*[Cv] <sub>σ</sub>	ONSET	*COMPLEX	DEP-IO
a- → ʔik.ta:b				*
b- kta:b			*!	
c- ik.ta:b		*!		
d- ki.ta:b	*!			

\*For the sake of simplicity, there are some other possible candidates have to be ruled out.

The input is the optimal form in CA. However, in LA, the three markedness constraints \*[Cv]<sub>σ</sub>, ONSET, and \*COMPLEX have ruled out the candidates (b), (c), and (d). Although candidate (d) is faithful to the input, the higher ranked constraint militating against open light syllables rules out this candidate. Candidate (a) has more segments than the input, but since the faithfulness constraint DEP-IO is low ranked, candidate (a) wins. The actual competition in the tableau is between candidate (a) and any of the other candidates. This competition is settled by the fact that markedness constraints dominate over the faithfulness constraint in this case.

### 3.2 Correspondence in Optimality Theory

OT was introduced in the first place to account for phonological processes (Prince and Smolensky, 1993; Prince and Smolensky, 2004a). However, due to advances in the understanding of prosodic morphology (McCarthy and Prince, 1986, 1993a ) which account for the interaction between phonology and morphology, and further advances in understanding the faithfulness of the output to the input (McCarthy and Prince, 1993b), OT has also been extended to account for morphophonological processes.

In languages which exhibit the reduplication of an instance, the correspondence identity of the reduplicant and the base from which the reduplicant is derived is expressed by copying either segmental or prosodic constituents. In total reduplication, the copying exhausts the whole word, whereas in partial reduplication part of the segments of the base is reduplicated. This faithfulness identity is shaped accordingly

to a theory known as Correspondence Theory to account for the identity between any two related grammatical representations (McCarthy and Prince, 1995).

### 3.2.1 Standard Correspondence Theory

Derivational morphological processes are largely affected by the interaction of faithfulness constraints which demand identity, and constraints on the output of structural configurations which may favour the modification of the input. This interaction causes unfaithfulness between the output and the input. McCarthy and Prince (1995) introduced Correspondence Theory to account for input-output faithfulness relations. This theory has been adopted by many linguists and has since influenced the study of phonological and morphological processes. The basic of this theory is restated below in terms of correspondence elements:

(120)

*‘Given two related linguistic forms  $S_1$  and  $S_2$ , correspondence is a relation  $\mathcal{R}$  between any subset elements of  $S_1$  and  $S_2$ . Any element  $\alpha$  of  $S_1$  and any element  $\beta$  of  $S_2$  are correspondents of one another if  $\alpha \mathcal{R} \beta$ ’ (McCarthy and Prince, 1995).*

These correspondence relations between  $\alpha$  and  $\beta$  can represent any phonological representation, for example segments, moras, syllables, heads of feet, or distinctive features. They are not limited to base and reduplicant identity and input-output relations, but can be extended to capture the relations between two stems, as in root-and-pattern, circumscriptive, or truncating morphology (McCarthy and Prince, 1999,4).

### 3.2.2 Transderivational Output-Output (O-O) Correspondence

The main idea of O-O correspondence is that ‘words in a paradigm are required to be phonologically identical by constraints on an identity relation between two surface words’ (Benua, 1995, 2004). The mechanism of correspondence can be represented as follows:



(121)

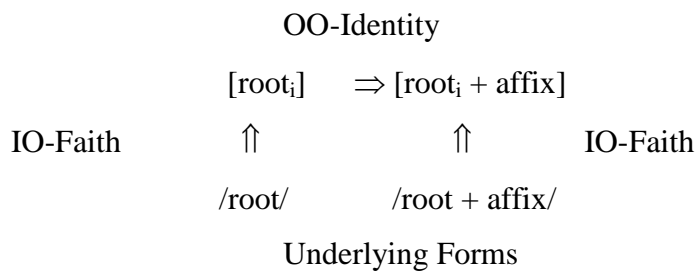

There are two linked correspondence relations that govern this mechanism: the first holds for input-output (IO) relations between the surfaced words and their underlying forms. That is to say, there is an identity or faithfulness relation between the output [root<sub>i</sub>] and its input /root/. Similarly, the output [root<sub>i</sub> + affix] is in an identity correspondence relation with its input /root + affix/. Then, the two output forms [root<sub>i</sub>] and [root<sub>i</sub> + affix] are linked to each other by a transderivational O-O correspondence relation. These relations are governed and evaluated by a set of faithfulness constraints between input-output relations as well as output-output relations. There are many types of IO-faithfulness constraints such as (MAX- IO, DEP- IO, IDENT- IO [F], etc.). Two related outputs are evaluated by IDENT-<sub>OO</sub> constraints such as (MAX-<sub>OO</sub>, DEP-<sub>OO</sub>, IDENT-<sub>OO</sub> [F], etc.).

O-O correspondence in transderivational relations reflects the phonological effects between two morphologically related words. This mechanism of O-O correspondence is assumed to express the mechanism of all types of morphological derivation: affixation, truncation, mapping to a template, and so on. (Benua, 2004, 420). It should be noted that the identity relation triggered by morphological derivation expresses only the relation between the derived word and its output base. Benua identified the base as ‘the independent word identified with the string that undergoes morphological derivation’ (Benua, 2004, 421). Benua stated that it is difficult to give a precise definition of the base. However, in affixation the base is said to be the word identified with the string attached to the affix (Benua, 2004, 421). Such derivational relations between the derived output and an output base require OO-correspondence relations. Building on this, the base and the derived word as independent outputs related by an O-O correspondence relation must be phonologically and morphologically well-formed structures.

### 3.2.3 Output-Output Correspondence Based on LA Plural Formation

From the perspective of O-O correspondence theory, there is no complete correspondence relation between the O-O nominal singular form and its correspondent O-O BP form. For example, the vowel features of the input are not carried over to the output, the vowel melody which fills the vowel positions in the template of the BP form is supplied independently of the input, and also the prosodic structure of the input has no correspondence relation with the prosodic structure of the output. However, the obvious correspondence relations which can be drawn from the input singular and its output BP form are: the consonantal roots of the input, which are mapped to their correspondents in the output BP form, and the weight of the heavy syllable of the final syllable of the input which is carried over to the final syllable of the BP output form. The preservation of the final heavy syllable, as seen later in the discussion of the derivation of some patterns of BP (see, for example, section 7.4.1), is related to certain morphophonological constraints which either require the preservation of some morphological properties of the input in the case of preserving the length of the long vowel, or some phonological constraints which require the syllabification of root consonants after the derivational morphological process has taken place. Such elements stand in correspondence and, in fact, are morphological properties; and there are no phonological properties that could be claimed to stand in correspondence relations. Thus, the only clear correspondence relations which can be drawn from this input-output relation between the nominal form and its derived BP form are, firstly, the string of the consonantal roots which are supplied for both the singular and the BP forms from an abstract consonantal tier. The second is the BP affixes which are supplied from a tier related to the derivational morphological process of the BP and are independent of the singular nominal input. It is evident that there is a lack of faithfulness relations between the nominal singular input and the output BP form. This argument prompts the question of what is the input for a BP form? Since, as many linguists believe for example, McCarthy (1979, 1981) Farwaneh, (1990) Ratcliffe (1990, 1998), the existence of an abstract consonantal tier has to be assumed, the input of the BP form must consist of these consonantal strings plus the BP affixes which are supplied by an independent tier which contains such affixes. The derivational morphological process of SP is different from that of BP. SP has a clear correspondence relation between the nominal input singular and its

correspondent output SP form, since the stem singular is carried over to the output. The suffixes of SP are straightforwardly attached to the stem, sometimes with help from an epenthetic consonant. If the stem ends in a glide this glide has to surface, because such suffixes lack onsets.

Based on the level ordering hypothesis (Kiparsky, 1982; Ratcliffe, 1990), it is suggested that this theory can be extended to account for Arabic morphology in which the morphological process is divided into ‘internal’ and ‘external’ types. In the internal type, the stem is subject to change in vocalism, as in /kataba/, ‘to write’  $\Rightarrow$  /ka:tib/, ‘writer’, whereas in the external type the stem is not affected since the operation is applied outside the stem and consequently does not have a phonological affect on it, as in /muʔallim/, ‘teacher’ (Masc. + Singular),  $\Rightarrow$  /muʔallimi:n/, ‘teachers’ (Masc. + plural +genitive). The internal type takes place in level I and the external type takes place in level II. The inputs for level I are ‘roots’ (abstract strings ranging between two and up to five consonants), vowel melodies, consonantal affixes, and prosodic templates (Ratcliffe, 1990,97). The distinction between BP and SP arises from the fact that the morphological and phonological processes operate within the stem in BP formation and outside the stem in SP formation.

As far as the non-concatenative morphology of the BP system of LA is concerned, there is no clear phonological or morphological correlation between the singular forms and their BP forms. Nevertheless, in many cases, the association of a nominal form with a specific BP form is morphosemantically motivated. There are some affixes that are associated with the formation of LA plurals, such as the suffix /-at/, the long vowel /vv/ which can be an infix or a suffix, and the glottal stop /ʔ/ in initial or final positions. The derivation of BP shows that the position of the long vowel of the BP affix is aligned productively in many BP forms, either after the second consonantal root  $C_2$  or the third consonantal root  $C_3$  as in /k<sub>1</sub>a<sub>1</sub>l<sub>2</sub>a<sub>3</sub>/, ‘dog’ (Masc.)  $\Rightarrow$  /k<sub>1</sub>l<sub>2</sub>a:b<sub>3</sub>/, ‘dogs’, where the BP morpheme is positioned immediately after  $C_2$  and in /ħ<sub>1</sub>a<sub>2</sub>k<sub>2</sub>i:m<sub>3</sub>/, ‘wise man’, (Masc.)  $\Rightarrow$  /ħ<sub>1</sub>u<sub>2</sub>k<sub>2</sub>a<sub>3</sub>a:ʔ<sub>4</sub>/, ‘wise men’, where the BP morpheme is positioned immediately after  $C_3$ .

Radical root consonants provide a direct formal derivational basis in the morphology of Arabic. For example, deverbal nouns which are derived from verbs make reference to the root consonants (Fox, 2003, 44). That is to say, root consonants are shared between the deverbal noun and the verb from which it is derived, as in /k<sub>1</sub>at<sub>2</sub>ab<sub>3</sub>/, ‘he wrote’, ⇒ /k<sub>1</sub>a:t<sub>2</sub>ib<sub>3</sub>/, ‘writer’. The root consonants √ktb are present in the two forms. The extra elements put forward by the deverbal noun are the long vowel that is positioned after C<sub>1</sub> and the epenthetic /i/ in the second syllable. The derivation of the active participle /k<sub>1</sub>a:t<sub>2</sub>ib<sub>3</sub>/ from its correspondent verb /k<sub>1</sub>at<sub>2</sub>ab<sub>3</sub>/ requires the insertion of the long vowel, which marks morphologically the active participle here, after C<sub>1</sub>. It is clear that the vowel features in the input are not transferred to the output form. Thus, the relation between /k<sub>1</sub>a:t<sub>2</sub>ib<sub>3</sub>/ and /k<sub>1</sub>at<sub>2</sub>ab<sub>3</sub>/ holds only for the shared root consonants in the two forms. Similarly, the derivation of the passive participle /m<sub>4</sub>ak<sub>1</sub>t<sub>2</sub>u:b<sub>3</sub>/, ‘written/letter’, requires only the root consonants /ktb/ and the derivational morphemes which mark the passive participle: /m/ initially as a prefix and the long vowel /u:/ positioned after the second root consonant C<sub>2</sub> /t/. Since /m/ does not belong to the root consonants in this example, in the derivation of its BP it is considered one of the string root consonants where it occupies C<sub>1</sub>, which gives /m<sub>1</sub>ak<sub>2</sub>a:t<sub>3</sub>i:b<sub>4</sub>/. Therefore, it is important to specify the nature and the components of the underlying structure, which is the input of any morphological derivational process. It is quite clear that such an underlying structure consists of the string of root consonants and any morphological process associated with the input prior to the derivation of the intended derived word. Another example from CA shows that activity and passivity are supplied independently of the input. The difference between the perfective active /kat<sub>1</sub>ab/, ‘he wrote’, and its corresponding perfective passive /kut<sub>1</sub>ib/, ‘it is written’, is marked by the vowel melody of each form which is marked morphologically.

Actually, the derived words of SP in general and BP in particular show that the base and its derived form are not identical. Since the derivational processes of plural formation involve affixation, it is noticeable that the affixation brings to the derived word some materials which do not have correspondents in the base form. For example, the derivation of MSP involves two O-O derivational processes: the first

holds for the OO-IDENT relation between the O-O active participle /muʕallim/ and its base the verb /ʕallam/; then in the second process, the relation holds for the O-O form /muʕallimi:n/ and its base, the active participle /muʕallim/. In each process the O-O form is checked for faithfulness relations against its underlying form through IO-FAITH. The examples below illustrate the mechanism of O-O transderivational correspondence in SP. Output forms are related to their inputs by an IO-correspondence faithfulness set of constraints that assure that the output word is faithful to its underlying form. The constraints IO-Faith include (MAX-IO, DEP-IO, IDENT-IO [F] EATURE, etc.). Each two output forms are evaluated by the OO-identity set of constraints such as MAX<sub>OO</sub>, DEP<sub>OO</sub>, IDENT<sub>OO</sub> [F] EATURE. Thus, affixation violates DEP<sub>OO</sub>. In order to achieve affixation, the DEP<sub>OO</sub> constraint must be always low ranked:

(122) OO-Identity ⇔ OO-Identity

/ʕallam/	⇒	/muʕallim/	⇒	/muʕallimi:n/
↑ IO-Faith		↑ IO-Faith		↑ IO-Faith
/ʕallam/		/ʕallam+mu/		/muʕallim+i:n/

#### Underlying Forms

First of all, the affixes that are associated with the two nominal words occupy different positions. In the active participle /muʕallim/, the affix /mu/ is a prefix and in /muʕallimi:n/ the onsetless affix /i:n/ is a suffix. Alignment constraints can be formulated to account for the positions of such prosodic and morphological constituents. Thus, to account for the alignment of the prefix and the suffix, two constraints are introduced:

ALIGN (Stem-R, AFFIX-L)

Align the right edge of the stem with the left edge of the affix so that the affix is identified as a suffix.

ALIGN (Stem-L, AFFIX-R)

Align the left edge of the stem with the right edge of the affix so that the affix is identified as a prefix.

The alignment of these constraints is maintained by the active morphological sites determined and specified by the language; otherwise the constraints may target the wrong edge. In other words, the activation of a morphological site triggers and directs consequently the activation of the phonological constraints, in order to well-form the product of the morphological structure.

The diagrams for both /ʕallam+ mu-/ and /muʕallim+ -i:n/ present the hierarchical prosodic representations, and show the coincidence of morphological edges and prosodic edges for both inputs.

(123) a- /ʕallam+ mu-/

b- /muʕallim+ -i:n/

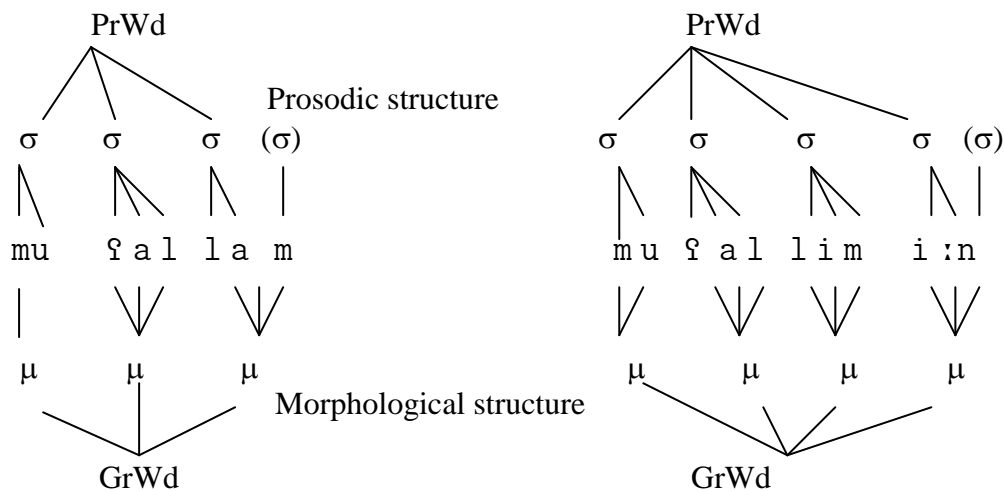

PrWd = prosodic word, GrWd = grammatical word, Parenthesized syllables express extrametricality

As can be seen from the two diagrams, the consequence of the two alignment affix constraints leads the suffixes to form new syllables. On one side, aligning the constraint ALIGN (Stem-L, AFFIX-R), which positions the prefix /mu-/ in (123-a) at the left periphery of the PrWd, leads to the creation of a light syllable since the vowel is specified with this type of active participle. Also, the vowel of the final syllable is assigned as /i/ because it is also marked by the derivation of the active participle. On the other side, aligning the constraint ALIGN (Stem-R, AFFIX-L), which positions the

suffix /i : n/ in (123-b) at the right periphery of the PrWd, results in an ill-formed syllable. This syllable lacks only an onset, since this suffix already has a nucleus and a coda. Thus, this ill-formed syllable attracts the preceding consonant to fill its empty onset in order to repair the onsetless syllable.

As a matter of fact, there is no relation between the input stem verb /ʔ<sub>1</sub>a<sub>1</sub>l<sub>2</sub>l<sub>2</sub>a<sub>m</sub><sub>3</sub>/ and the derived active participle /m<sub>4</sub>uʔ<sub>1</sub>a<sub>1</sub>l<sub>2</sub>l<sub>2</sub>i<sub>m</sub><sub>3</sub>/. The vowels of the first syllable and the last one in the derived word are assigned and supplied by the morphological process of the active participle. Hence, it is hard to observe any phonological faithfulness relation between the input and the output other than in the preservation of the consonantal roots. Thus, the input should consist of the consonantal roots plus the components of the morphological process associated with the input, which here is the root consonant plus the doubling of the medial consonant, and of that of the derived word which is the prefix /mu/ and the vowel /i/ as a nucleus of the final syllable. To present these diagrams in OT account, consider the syllable structure of the possible outputs for the two nominal forms. Notice that the dots show the syllable boundaries:

(124) Interaction of constraints to derive [muʔllim] from [ʔallam+mu-, /i/]:

Input: [muʔllim]	Align (Stem-L, AFFIX-R) and /i/ (FINAL SYLLABLE)	*COMPLEX	DEP
a. → /m <sub>4</sub> u.ʔ <sub>1</sub> a <sub>1</sub> l <sub>2</sub> l <sub>2</sub> i <sub>m</sub> <sub>3</sub> /			*
b. /m <sub>4</sub> uʔ <sub>1</sub> l <sub>2</sub> l <sub>2</sub> i <sub>m</sub> <sub>3</sub> /		*!	
c. /ʔ <sub>1</sub> l <sub>2</sub> l <sub>2</sub> i <sub>m</sub> <sub>3</sub> . [m <sub>4</sub> u]/	*!	*	

The morphological process requires the morphemes to be positioned in their places within the morphological domains available and motivated by the derivational process. Accordingly, the morphemes of the active participle are assigned morphologically within available sites close to the root consonants. The prefix /mu/ is positioned in the site preceding the first root consonant, while the vowel morpheme /i/ is positioned in the site available between C<sub>2</sub> and C<sub>3</sub>. This gives the underlying structure [m<sub>4</sub>uʔ<sub>1</sub>l<sub>2</sub>l<sub>2</sub>i<sub>m</sub><sub>3</sub>] which needs to be phonologically checked in order to meet the wellformedness requirements of the language. At the level of underlying structure in the morphological derivational process, the phonology has not assumed any role.

After marking the requirement of the morphological process, there are many possible output candidates available to compete with the underlying form, one of which is the underlying form. The availability of such candidates in fact reflects the competition between the markedness and faithfulness constraints of the language. Hence, the candidates in the tableau above are just three possible candidates among an unlimited number until the top-ranked constraints of the language are met and satisfied.

In the tableau, it is assumed that the top ranked constraint is morphologically motivated in order to guarantee that the morphological morphemes are positioned in their morphologically assigned places. The first constraint which comes into play after the derivational morphological process is the constraint which militates against margin clusters. Because of the nature of the root consonants and the morphological morphemes, the first expected structure of the underlying form has margin clusters. This is because the phonology has not yet affected the resulting morphological structure. In this light, candidate (c) is ruled out because it fails to locate the correct position of the prefixal morpheme /mu/. Candidate (b) is ruled out because it consists of margin clusters. The winning candidate (a) avoids such margin clusters by inserting an epenthetic vowel. Because DEP is ranked low, the optimal candidate is considered to minimally violate only the low ranked constraint and maximally satisfies the top ranked constraints. In the following tableau, the derivation of the SP /muʔallimi:n/ is explained:

(125) O-O correspondence between base /muʔallim/ and output /muʔallimi:n/

Base: /muʔallim/	ALIGN (Stem-R, AFFIX-L)	ONSET
Output: /muʔallimi:n/		
a- → /mu.ʔal.li.mi:n/		
b- /mu.ʔal.li.mi:i:n/		*!
c- /mu.ʔal.li.m/[i:n]	*!	

The tableau shows that, candidate (c) is ruled out because it violates the alignment constraint. The tableau does not show competition between the constraints, but rather shows the resyllabification of segments so as to avoid onsetless syllables caused by the alignment of the onsetless suffix [-i:n]. It is clear that the derived SP form



reflects the properties of the base. Such derivation involves a stem modification to the input form (Steriade, 1988; Bat-El, 1994).

### **3.3 The Input for Non-concatenative Morphology**

It has been assumed that the derivation of morphology in Semitic languages only makes reference to the root consonants (McCarthy, 1979, 1981), since the root consonants of related words have shared semantic meaning. The root consonants are hence assumed to be the source of the derivation of any two or more related words. The two widespread morphological approaches to Semitic morphology, templatic morphology and prosodic morphology, have in common the assumption of the existence of invariance templates as independent lexical units. In templatic morphology, consonants and vowels are represented in different abstract tiers and are mapped to another abstract level which is represented as an invariance template in one-to-one autosegmental association. On the other hand, the association in prosodic morphology is based on prosodic unit mapping in the sense that the prosodic elements of the input are maintained in the output derived word.

Nevertheless, the existence of independent root consonants has been challenged by many researchers. For example, it has been claimed that denominal verbs in Hebrew are not derived from the string of root consonants, but rather from their corresponding independent base nouns. This claim is supported by the fact that the vowel and second consonant of output nouns make direct reference to their denominal verbs. Also, consonant clusters of the base nouns are preserved in their corresponding denominal verbs ( Bat-El, 1994, 2002; Ussishkin, 1999, 2000, 2006). Accordingly, the relation between the two related forms is seen as an O-O correspondence relation and not as a relation between the root consonants and the output form. In other words, the relation between the base and the output is said to be closely related, in the sense that the output makes a direct reference to the stem word as a whole and not just to the root consonants.

However, the root consonants are still shared between the two correspondent outputs. In addition, the preservation of the short vowel and the second root consonant might

be attributed to faithfulness to morphological derivational processes which require these morphological components to be preserved in the derived output. Thus, such relations can not be captured by O-O corresponding relations, but rather by accounting in IO relations the segments and the morphological properties that are transferred to the output, and then similarly accounting for the segments and the added derivational morphological morphemes that are inserted in the output in output-input relations. In such corresponding relations, the underlying structure of the derived word could be accounted for, which will yield the segments and the morphological components of the input that are transferred to the output plus the added derivational morpheme which is supplied by the intended morphological process.

O-O correspondence theory reveals that the morphology of the base and that of the output are distinct. Consequently, the phonology of the base is also distinct from the phonology of the output. This is due to the relationship between the morphology and phonology of a derived word. Morphology interacts with phonology in that it creates the objects on which the rules of phonology operate (Halle and Jean-Roger, 1987,78). Thus, any word generated by the morphology must be reviewed by the phonology to determine whether it is well-formed. In cases where the output of the morphology is not phonologically well-formed the phonology will repair the ill-formed word.

The morphological and phonological structures of the base must be clearly distinguished from those of the output BP based on a faithfulness relation. The question which should be investigated concerns whether the morphology and the phonology of the output are faithful to the corresponding components of the input. The morphological processes of the input and the output are clearly distinguishable and represent two different processes. However, it is unclear whether or not the phonological processes of the output are faithful to those of the input in such a way that there are two corresponding phonologies, or whether there is only one phonology that operates on any morphological derivational process. At the morphological level, the elements of the base which are preserved, or not, in the output can be considered. The morphologically preserved elements of the base are the string of consonantal roots, which have a morphological function at the abstract level of representation, and usually their precedence order, the long vowels which often have a morphological

function, the autosegmental spreading of segments, and the active morphological sites which are assumed to be active in any morphological operation. At the phonological level, there are no phonological elements of the base that can stand in correspondence with the phonological elements of the output. For example short vowels and the syllable structure of the base lack correspondents. Now, the situation can be considered the other way around starting from the output to the input. Morphologically, the output BP form has the plural affixes which do not have correspondents in the base input, and also derivational epenthetic segments such as doubling a consonant to represent intensity or repeated actions. Phonologically, apart from the root consonants themselves, there are no phonological structures of the base can stand in correspondence with the phonological structures of the derived word.

The morphological operations of the base and the derived output stand in correspondence as distinctive morphological processes because each word is associated with a different morphological process. Similarly, the phonological processes of the base and the derived word are distinctive because their phonological elements do not at all stand in faithfulness correspondence relations. The existence of phonological relations of correspondence between the base and the derived word is assumed by those who adopt templatic and prosodic morphology. Their assumption is based on the mapping of the components of the base to an invariant template shape for the derived word. But, the shape invariant template assumed by templatic morphology and prosodic morphology does not exist as an independent unit in the lexicon. Rather such templates are the result of phonological constraints which operate on the outcome of any morphological process in order to construct a well-formed structure. The motivation to disregard the existence of the shape invariant template is driven by the fact that non-concatenative morphology involves infixational materials into active derivational morphological sites. Such active morphological sites presume the existence and the vital function of root consonants in any morphological process. Thus, the input for a non-concatenative morphological process is the string of root consonants plus the derivational morphological morphemes, for example a morpheme that assigns the derivation of BP or active participle. Then, the phonology takes part in constructing the most well-formed structure preferred by the language, based on the hierarchy of the phonological constraints. As a consequence of this claim, the template can be seen as the result of phonological constraints operating on

a morphological input (see detailed discussion in chapters five for nouns, six for adjectives, and seven for BP for detailed discussions). Ussishkin (2006) suggested that these phonological constraints demand prosodic structures to meet both the minimality and maximality requirements of prosodic markedness effects that shape both the base and the output. He identified these prosodic requirements as fixed prosody. This fixed prosody represents the well-formed prosodic structure of the language. However, although Ussishkin's disagreement with the existence of the independent template is accepted, two assumptions of fixed prosody cannot be accepted. The statement of fixed prosody is based on a faithfulness relation between the stem and the output which Ussishkin claims work in Hebrew. However, as far as the derivation of the non-concatenative morphology of LA is concerned, such a faithfulness relation does not exist. The second issue is his denial of the importance of the role of root consonants. However, such an identification of root consonants is vital in the derivational processes of non-concatenative morphology.

Therefore, we assume that the existence of the template is better understood as the result of the interaction of phonological constraints operating on a given morphological output. Similar accounts have been given for Coptic (Kramer, 2007) and Iraqi Arabic (Tucker, 2011). In these two studies, a root and prosody approach is suggested to account for a non-concatenative morphology. Their central claims are presented as follows:

- Roots and vowels are morphemes: the input consists of root consonants plus a 'discontinuous' vowel affix (for example, /a/ for the perfective aspect, /a:/ for some BP forms).
- Templates are given by prosody: templates are the properties of words which surface from the necessary satisfaction of high-ranking prosodic markedness constraints.

The underlying structure of the output BP, then, is revealed to be the elements standing in correspondence with the base plus any additional derivational affixes evaluated by phonological markedness constraints. Elements of the base that lack correspondents are also evaluated by faithfulness constraints, but the latter will be low

ranked, so the optimal candidate can survive its violations of them. The markedness constraints will evaluate output candidates until an optimal one is determined.

The overview of the non-concatenative morphology of BP reveals that the phonological constraints are a set of constraints which operate on any derived word. The structures resulting from the morphological derivational processes of any non-concatenative related words are checked according to all the active phonological constraints involved in the process of forming the well-formed structures of those words. In other words, phonological constraints are not activated by an individual morphological process; rather, they are always present in order to repair any ill-formed structure produced by any morphological process. In understanding the mechanism of the non-concatenative morphological processes of word formation, OT can deal with and process any derived word. The ability of OT to process morphological components is due in fact to the hierarchy and violability of constraints. In many languages, concatenative or even non-concatenative morphological processes are examined by alignment constraints which force morphological components to be positioned in certain positions in the derived word. Where an alignment constraint is highly ranked processing the morphological process, this can cause the violation of a low-ranked constraint. Nevertheless, such violation should always be minimal and should never be more than necessary. Aligning affixes to any edge of a part or a whole derived word will not violate all of the faithfulness relations between the derived word and the source of derivation. The problem, nonetheless, is how to process infixated derivational morphemes in a non-concatenative morphology by imposing alignment constraints.

In fact, one of the most troublesome challenges for OT is the identification of the input for any morphological process in a non-concatenative morphology. In languages which exhibit partial or complete reduplication, for instance, OT successfully presents many insights into the interaction between prosodic structures and alignment constraints, where derivational morphemes or copied reduplicated prosodic elements are aligned in respect of phonological constraints with full or partial faithfulness to the input. The problem arises from the lack of recognition of morphological processes as explicit and independent properties of the grammar. The simplest definition of morphology is the study of how morphemes are combined to construct lexically

meaningful words. In pre-OT approaches, morphology was not explicitly recognized as an independent component of grammar. Nonetheless, Kiparsky (1982, 1985) and Mohanan (1985) among others separated out the morphology from the rest of the grammar in *Lexical Phonology*. Word structure was dealt with by the interactions between phonology, syntax, and semantics. In order to reach a well-formed output derived word, the derivational process starts by transforming some given input, which usually represents the underlying structure, and subjects it to a string of rules until the optimal output is achieved. During this complicated process, each rule derives one output at a time. Then, this output surfaces as an input for another derived output motivated by a new added rule. Such derivational rules are linear and could be phonological, syntactic, or semantic rules or all of them together.

In rule-based approaches, the structural condition and change of the derivational process are expressed and linked in the rule. Each rule modifies the structural change only once in each derivational process. This process of one step at a time reveals the fact that rule-based processes are blind to the optimal well-formed output. However, in OT as a constraint-based approach, structural condition and structural change in the derivational process are evaluated by other possible constraint violations. By this evaluation, markedness and faithfulness constraints contribute and motivate many structural changes. Thus, any possible structural change is cross-checked with the optimal output form. This is in fact one of the advantages of OT where any possible candidate is evaluated by all of the hierarchically ranked set of constraints. Nevertheless, because OT involves parallel mapping between the input and the derived output, identifying the structure of a morphological process of the non-concatenative type would cause difficulty if the actual input is not identified. Otherwise, the parallel mapping of OT has to borrow a grammatical rule in order to trigger the morphological process. Demonstrated in the present discussion of the components of morphological derivational processes for non-concatenative morphology, this should cause no problem in formulating the exact structure of the input. This is because all the relevant components of the morphological process are identified. As soon as such input is derived, the parallel mapping can map the input to any possible output. The evaluation of the outputs conducted by cross-checking against active markedness and faithfulness constraints in order to justify the well-formedness of the optimal candidate. Therefore, identifying the exact morphological

process keeps the surface level in the interaction of constraints, disallowing intermediary levels between the source of derivation and the derived output.

Augmenting non-concatenative derivational morphemes turns out to be the only challenge in order to run the parallel mapping of OT between the input and the output. If the elements are determined of the source of the derivation that are carried over to the derived output, which are the root consonants plus in some cases some morphological properties associated with the input, as well as infixation, placing derivational morphemes in their right active morphological sites, these elements of the input plus the derivational morphemes form the underlying structure of the morphological process. Consequently, this underlying structure is the actual input for the parallel mapping of any possible output derived candidate. This mapping is evaluated by the relevant active phonological and morphological constraints.

### **3.4 Lexicon Optimization from Non-concatenative Morphological Perspective**

Lexicon optimization in classical OT literature, and as interpreted by its founders Prince and Smolensky (1993, 2004), seeks to account for how OT principles naturally project the structure of the language's grammar into its lexicon. That is to say, how a language acquirer/learner identifies the right input, which represents the underlying structure, to the optimal output, which is the surfaced optimal form. The difficulty in identifying the right input is its infinite or at least the multiplicity nature to create many input candidates. This is governed by one principle of OT 'Richness of the Base', which does not put any restrictions on the input candidates as long as they are phonetically interpreted, grammatically permitted, and logically acceptable. Such mapping between many possible inputs to only one optimal output creates a lack of faithfulness between any input candidate and the optimal output. Prince and Smolensky related this difficulty of identifying the right input to the interaction of constraints which, they assumed, exist in the lexicon. Their statement of the lexicon optimization principle is as the following:

(126) Lexicon Optimization (Prince and Smolensky, 1993, 2004)

*Suppose that several different inputs  $I_1, I_2, \dots, I_n$  when parsed by a grammar  $G$  lead to corresponding outputs  $O_1, O_2, \dots, O_n$ , all of which are realized as the same phonetic form  $\Phi$ . These inputs are all phonetically equivalent with respect to  $G$ . Now one of these outputs must be the most harmonic, by virtue of incurring the least significant violation marks: suppose this optimal one is labelled  $O_k$ . Then the learner should choose, as the underlying form for  $\Phi$ , the input  $I_k$ .*

In this statement, the acquirer/learner of the language would choose the input that minimally violates the hierarchy of the constraints of the language. However, such an assumption means that lexicon optimization predicts fully specified lexical entries. Another problem with this statement is the lack of distinction between phonological and morphological structures. Bearing in mind that OT was originally introduced to account for phonological processes, there is no distinction between the morphological component and the phonological component as independent modules in the grammar or as distinguishable morphological structure from the phonological interpretation of that structure.

The consequence of this lack triggers infinite inputs as well as infinite constraint interactions. Our discussion to the nature of the input in non-concatenative morphology cuts the edge between morphological processes and phonological processes in such a way the morphology and the phonology are treated as individual components of the grammar/lexicon. This underlies the economical nature of the lexicon. Such nature maintains, for instance, few lexical entries, underspecification in lexical entries, as well as underspecification of phonetic contrasts.

The input in the non-concatenative morphology is identified as the string of root consonants, plus sometimes some morphological properties carried over from the source of derivation to the output, and the derivational morpheme/s supplied by the intended derivational process. As mentioned earlier, the string of the consonants are semantically governed i.e. the linearity of the string carries and denotes a semantic meaning maintained by the consonants and their consecutive order. Both the root consonants and the derivational morphemes are phonetically well-structured in the sense that both root consonants and the derivational morphemes carry meaning interpreted phonetically. That is to say that there is a semantic-phonetic relationship



between these elements of the morphological derivational process. This means that these morphemes, the root consonants and the derivational morphemes, are individually listed in the morphological component of the lexicon either as one unit containing both or as two where the root consonants are separated from the derivational morphemes in sub-components within the morphological component.

Thus, lexicon optimization cannot and should not be the most important mechanism to generate lexical entries. This is simply because the morphological processes take place first and are created independently before any interaction or interference from the phonological constraints. This yields that the underlying structure of the input is a morphological product. And this morphological product has yet to be submitted to the phonological component of the grammar in order to subject it to the phonological processes motivated by the need to parse the morphological units/segments. In the parsing process, the morphological segments seek complete faithfulness relations between the input and the output; otherwise the morphological derivational process cannot be identified or preserved. Such faithfulness constraints must be undominated. The phonological process comes to play its role after the morphological process is formed. The function of the phonological constraints is to parse and syllabify the morphological segments when they surface.

Treating the underlying structure i.e. the input, as ill-formed structure does not mean that the grammar of the language rejects or does not have this form. It is rather related to the fact that the underlying structure consists of and fulfils only the morphological process. The grammar requires such structure to undergo another process in the phonological component to be checked by the phonological constraints. In fact, the morphological process creates only one input. In the phonological component, the possible outputs of the underlying structure are generated based on the interaction of the phonological constraints on each possible output. The most harmonic output is the one which satisfies all the top-ranked constraints and minimally violates the low-ranked ones. Based on this harmonic output, the acquirer/learner of the language, then, infers both morphological and phonological information from the output.

Before the acquirer/learner of the language, there are two processes to fulfil. On one hand, s/he has to identify the morphological process i.e. the string of root consonants

and the derivational morpheme/s, which creates the input. On the other hand, and based on and as a consequence of identifying the morphological process, s/he has to identify the active phonological constraints which maintain that only one optimal output surfaces.

The more global optimization of the lexicon can be achieved not by form-by-form optimization, but rather by minimizing the totality of the underlying materials exist in the lexicon. This is exactly what it has been argued here in the nature of the lexicon based on non-concatenative morphology. Such economic and minimality requirements on materials in the lexicon are interpreted by the existence of root consonants and the derivational morphemes in the morphological component. These materials, when they are generated by the intended morphological process, have to go to the phonological component to be checked by the phonological constraints.

### 3.5 Conclusion

This chapter has presented an overview of OT. One of the main concerns was the correspondence relations between the input and the output derived word. It was revealed that in non-concatenative morphology, such as in the morphology of the active participle and BP, the correspondence relations between the derived word and the source of the derivation are not complete. In such grammatical correspondence relations, the phonological components of the input do not correspond to those of the output derived word. The two corresponding words reflect two distinct morphological processes. However, the root consonants, plus sometimes morphological components related to the input are carried over to the output. The underlying structure of BP, for example, consists of the string of root consonants plus any morphological elements related to the input and the BP morphemes which were supplied by the morphological process of the BP. As a consequence of these findings, any morphological property carried over from the input to the output must be preserved by faithfulness constraints. The nature of such morphologically transferred properties reflects in fact faithfulness to derivational morphemes which have lexical properties. As soon as the morphological process is structured, the phonological constraints are motivated at the surface level to modify any ill-structured form. Therefore, the constraints at work are stimulated by the phonology in order to maintain the good formation structure of the morphologically derived words. Whatever the structure of the optimal candidate, the good formation structure must not be thought of as the consequence of mapping an input to a well-formed pre-existing template. The template turns out merely to reflect phonological constraints operating on a morphological process. As a result of this, well-formed templates are seen to be the result of morphophonological processes.

The outcome of this chapter is the identification of the nature of the input in non-concatenative morphological processes. This significance of identification is vital in understanding the non-concatenative morphology of nouns and adjectives, and the derivation of BP. It is impossible to grasp the derivational process of non-concatenative morphology, as well as to justify the surface structure of the optimal output candidate of any morphological process of this type without specifying the nature of the input for derivational non-concatenative morphological processes. The failure to identify the nature of the input is the main weakness of previous studies that

have investigated the nominal system and specifically the formation of BP in Arabic. Such confusion in previous studies can also be related to the lack of identification of the morphological processes independent of the relevant phonological processes. In other words, morphological processes take place first, which give the underlying structure for any derived word, and then phonological processes take place at the surface level to structure the underlying form. The distinction between morphology and phonology in non-concatenative morphological processes is essential in order to justify any relevant morphophonological process. In doing so, the nominal system that exhibits non-concatenative morphology can be better understood.

The follow chapter presents the phonological structure of the word in LA, and aims to develop a picture of the phonological constraints related to the derivational morphological processes which well-form the derived word.

## **Chapter 4: The Prosodic Structure of Libyan Arabic**

Although autosegmental elements are parts of a word whether it is derived or nonderived, the broadest understanding of a word can be better appreciated by considering the suprasegmental elements. Any well-formed word has to have its components, such as consonants and vowels, syllabified. Phonologically, the word must have at least some type of prosodic structure to its segments. Such a prosodic structure starts from minimally fulfilling some type of syllable structure and maximally extending to the prosodic phrase. This chapter presents the structure of the syllable as well as the related prosodic structures, focusing also on the phonological constraints that shape a well-formed word in LA. The syllable is the main focus for two reasons. The first is its importance in parsing the segments, and the second is prompted by previous studies investigating BP formation which take either the autosegmental or moraic approaches to syllabification. Then, an optimality theory account of the syllable is presented to account for the interaction of related constraints which shape the well-formed word. Following this, the patterns of syllabification and the phonotactical phenomena related to the structure of the syllable are also accounted for. Then, the structure of the prosodic word and stress assignment are explained.

### **4.1 Introduction**

Since phonetic transcription is used to represent the actual pronunciation of words used as examples, it is worth shedding some light on the phonetic differences between segments in CA and LA. In CA, the vowel system is very limited. It consists of three short vowel phonemes: the palatal /i/ and labio-velar /u/ which are both closed, and the guttural /a/ which is an open vowel. Long vowels in CA are prolongations of the corresponding short vowels. These long vowels are /i:/, /u:/, and /a:/. Modern Arabic dialects have at least these long vowels (Watson, 2002, 21).

The inventory of the LA vowel system consists of ten vowels, they are: [i:] /ʔi:d/, ‘feast’, [i] /silim/, ‘peace’, [e:] /se:f/, ‘sword’, [a:] /sa:s/, ‘wall’, [a] /katab/, ‘he wrote’, [ɑ:] /bɑ:ba/, ‘dad’, [ɑ] /sʔɑdɑr/, ‘chest’, [o:] /jo:m/, ‘day’, [u:] /sʔu:r/, ‘fence’, and [u] /ħumʊr/, ‘red’ plural. The mid-vowel phonemes [e:] and [o:] are allophonically short in the final position of a word (Abumdas: 1985, 41). Harrama (1993, 24) has listed a total of eight vowels for the Al-Jabal Dialect (JDLA). Although Harrama did not explicitly include the pharyngealized vowel, he mentioned the environment within which the vowels are realized as emphatic and more backed in an environment of emphatic consonants. In Eastern Libyan dialects, Owens accounted for eleven vowels. The extra vowel is [o] which is found in a handful of examples in the dialect such as /mo/, ‘not’ and /moʃ/, ‘not’ (Owens, 1984, 11). This vowel also exists in the SD as in /xo/, ‘brother’ and /bo/, ‘father’, for example. The overall map of the phonemic vowels of LA is given in the follow chart:

(127)

	Front		Central		Back	
	Short	Long	Short	Long	Short	Long
High	i	i:			u	u:
Mid		e:	ə		o	o:
					ʌ	
Low	a	a:			ɑ	ɑ:

The long vowels /e:/ and /o:/ are the actual surface of the CA diphthongs /aj/ and /aw/, respectively. Owens (1984, 10) claimed that in the dialect he studied, the diphthongs are preserved only after the sounds /ħ/, /h/, and /ʔ/, as for instance in /ħawʃ/, ‘house’, and in the incomplete verb suffixes /-aj/ (feminine + singular) and /-aw/ (masculine + plural). The diphthong may be preserved, as in the preceding examples; however, the addition of a suffix may cause the diphthong to surface as a long vowel as in /jaʃrubaw/, ‘they drank’ ⇒ /jaʃrubo:ha/, ‘they drink it’ feminine. Furthermore, diphthongs may be preserved almost fully, as in /rawʃan/, ‘window’ (Mitchell, 1975 cited in Owens, 1984).

In the consonant system of LA which is represented in the follow chart, LA preserves all the CA consonants phonemes:

(128)

		Bilabial	Labiodental	Dental	Dento-alveolar	Post-alveolar	Palatal	Velar	Labial-velar	Uvular	Pharyngeal	Glottal
Plosive	voiced		b		d			g				
		Pharyngealized			d <sup>ʕ</sup>							
	voiceless				t			k		q		ʔ
		Pharyngealized				t <sup>ʕ</sup>						
Fricative	voiced		(v)	ð	z	ʒ					ʕ	
		Pharyngealized			ð <sup>ʕ</sup>	z <sup>ʕ</sup>						
	voiceless			f	θ	s	ʃ		x		ħ	h
		Pharyngealized				s <sup>ʕ</sup>			y			
Trill					r							
Nasal			m		n							
Lateral					l							
	pharyngealized				l <sup>ʕ</sup>							
Approximant						j			w			

(Parenthesised segments are borrowed from European languages)

The fricative pharyngealized voiced dental-alveolar [z<sup>ʕ</sup>] does not exist in CA, and is associated only with a few words in LA such as /z<sup>ʕ</sup>immi : ta/, ‘kind of food made from flour’ and /gaz<sup>ʕ</sup>z<sup>ʕ</sup>a/, ‘kind of rough sand’. The phoneme [v] only exists in LA in loanwords from European languages. The voiceless uvular stop [q] is associated with loan words from CA. The actual surface of this phoneme is realized as the voiced velar stop [g]. The usage of [q] can distinguish between literate and illiterate people. Generally speaking, literate people tend only to preserve [q] in words related to the Quran or official terminology. Another instance related to the difference between CA

and LA is the realization of the glottal stop [ʔ]. In cases where the glottal stop [ʔ] occurs word-initially, it preserves all its features. However, if it occurs word-medially or word-finally, it usually loses its features and surfaces as either a long or short vowel, as in /sa'ma:ʔ/ which surfaces as /sa'me:/ or /sa'me/. The LA dialects are distinguished by the surface realization of some phonemes. For example, the fricative voiced dental [ð], fricative voiced pharyngealized dental [ðˤ], and fricative voiceless dental [θ] may or may not surface as the plosive voiced dental /d/, plosive voiced pharyngealized dental [dˤ], and plosive voiceless dental [t] respectively.

An overview of LA dialects in general terms reveals that it has three main dialectal areas (Owens, 1984, 239). The first is in the West, spoken in Tripoli and the surrounding areas; the second is in the East, spoken in Benghazi and the surrounding areas; and the third is Transitional, which is spoken in areas between the above mentioned dialects and in the south of the country where transitional refers to the effect of the other two dialects. The map below shows the approximate distribution of these dialects:

(129)



(Note that some city names may appear with different spelling (e.g. Surt=Sirt)  
Retrieved from ([http://libya.embassyhomepage.com/libya\\_map](http://libya.embassyhomepage.com/libya_map)), on 20<sup>th</sup>/May/2011.



According to this division, SD, the language under investigation, is considered as a transitional dialect. Nevertheless, such divisions of dialects based on geographical areas should not be taken for granted since people in big cities often come from different areas. Although it is not always easy to draw a line between the dialects, there are some distinctive features separate those in the west and the east of Libya, especially in Tripoli and Benghazi. The difficulty in drawing these distinctions is due to the fact that inhabitants of these regions represent the tribal texture and diversity of linguistic features of the dialects.

To the researcher's best knowledge, there has never been a comprehensive study accounting for the similarities and/or differences between LA dialects. Most studies take a descriptive approach to individual dialects. However, one study (Owens, 1984) has investigated the eastern dialects of Libya focusing on Benghazi and its closely related surroundings. In this study, Owens accounted for the general linguistic features that are shared between these dialects. The overall picture of LA shows that research into LA dialects, most of which involves PhD studies mentioned many times throughout this thesis, have investigated only an individual dialect in the light of CA. Nevertheless, based on geographical areas, Owens (1984, 239-243) briefly drew some generalisations which distinguish the linguistic structure of the three main well recognized areas. At the phonological level, Sorman (a western dialect) deletes unstressed short vowels as in /ʒ<sup>1</sup>bal/, 'mountain', whereas Benghazi (an eastern dialect) tends to preserve this vowel as in /ʒi<sup>1</sup>bal/. In addition, Tripoli (a western dialect) tends to raise final short vowels in closed unstressed syllables, and raises final front low vowels as in /ʔ<sup>1</sup>ʃe/, 'supper' and /<sup>1</sup>kammil/ 'he finished', whereas the Benghazi dialect tends to lower these vowels as in /ʔa<sup>1</sup>ʃa/s and /<sup>1</sup>kammaL/.

Nouns of the form /CvCCvC/ which have a guttural sound in the second consonant position are realized as /vCCvCvC/ in eastern dialects. For instance, in Darj (western dialect) /<sup>1</sup>taʔlib/, 'fox' is realized as /iθ<sup>1</sup>ʔalab/ in Benghazi. Similarly, the adjective form /CvCvC/ as in /<sup>1</sup>axd<sup>ʔ</sup>ur/, 'green' in the Darj dialect is realized as /<sup>1</sup>xad<sup>ʔ</sup>ar/ in the Benghazi dialect. The distinction of masculine and feminine plurals reveals another linguistic distinction between eastern and western dialects. The

Tripoli dialect tends to overgeneralize masculine markers, whereas Tobruk (eastern dialect) tends to preserve the distinction of gender, as in the Tripoli /'kamml-u/, 'they finished' for masculine and plural which is realized as /'kammil-an/, for feminine and /'kammi-l-o/, for masculine.

At the lexical level, the differences in the lexicon between the eastern and the western dialects are clearly distinguishable. These differences are related to the multiple meanings of words and to the association of the meaning of one word with a specific situation or object. For instance, in eastern dialects the word /'bukra:/, 'tomorrow', corresponds to /'yudwa:/ in western dialects. Both of these words refer to the future. In Sebha (transitional dialect), some phonological features are shared with the eastern dialects, but the lexicon is generally grouped with western dialects. Misurata (transitional dialect) has similar features to Sebha, but tends to be more like the western dialects (Owen: 1984, 241). The phonological features and lexical characteristics of the nominal system of SD will be investigated in detail in this thesis.

As far as the differences between the LA dialects are concerned, some of the most obvious differences are motivated by preferences in the syllabification of the open light syllable, the deletion or preservation of the unstressed short vowel in open syllables, and the preference for using one lexical word over another. It is difficult to assume that one dialect is the input for another, yet CA can be strongly claimed to be the input for all LA dialects. Thus, the differences between LA dialects are represented mainly at the surface phonological level.

As will be demonstrated throughout this thesis, LA is similar to CA. Nevertheless, LA has been influenced by many other languages such as Italian, Turkish, Berber, French, and English. This influence has enriched the lexicon of LA while it hardly influences the grammar at all. Most of the borrowed lexicon is from Italian and generally could be categorized as relating to modern equipment and facilities such as machinery parts, workshop equipments, spare parts, and electrical equipment. Consider the following examples from SD:

- |       |                         |           |
|-------|-------------------------|-----------|
| (130) | /warʃ-at/, ‘workshop’   | ‘English’ |
|       | /ʃing-at/, ‘chain’      | ‘Italian’ |
|       | /gazar/, ‘drawer’       | ‘Spanish’ |
|       | /sa:ɡim/, ‘large spoon’ | ‘Berber’  |
|       | /kundar-at/, ‘shoes’    | ‘Turkish’ |
|       | /zo:fri:/, ‘cheater’    | ‘French’  |

All these examples are loanwords from different languages; however, all of these words are adapted to the phonological and lexical requirements of LA in general and SD in particular (more details can be found in section 7.6).

It has always been assumed that the internal syllable structure consists of an obligatory nucleus preceded by an optional onset and followed by an optional coda. The nucleus and the coda together form the rhyme. In LA, the onset and the nucleus are generally obligatory. The conventional syllable structure is formed in a tree-branching form, so that, for example, the preposition /min/, ‘from’ is formed as follows:

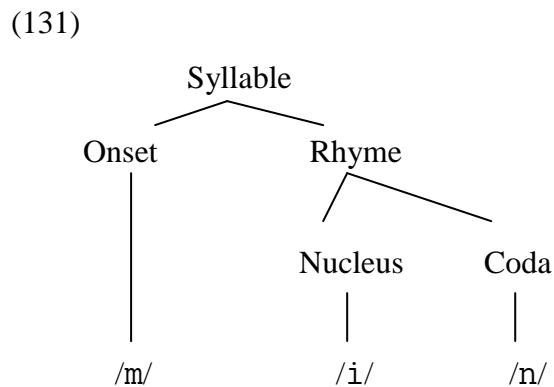

The onset and the coda may each consist of more than one consonant each. The nucleus consists of minimally one vowel and maximally two vowels.

## **4.2 Previous Accounts of CA Syllable Structure**

The main idea behind the presentation of the three schools of thought about syllable structure is motivated by previous studies that have investigated the formation of BP. In each of these studies some assumptions are made about the syllabification process in the derivation of BP or even the prosodic nature of BP templates. In earlier studies, the autosegmental elements of consonants and vowels are taken into consideration. In a later stage, other studies assume the standard prosodic structure where the prosodic elements are seen as representative of the weight of syllable structure. The OT approach to the syllable is expressed by the interaction of constraints, whatever their nature as autosegmental or prosodic. Thus, no single school is favoured over the other. In fact, the autosegmental approach is accepted in order to account for the consonant and the vowel as independent segments in the morphological derivational process. Likewise, the prosodic approach is accepted to account for the weight of the syllable and the preference for one syllabic structure over another. Both types of constraint of autosegmental and prosodic structures are set in an interactive competition among constraints in order to achieve the optimal output candidate.

It must be noted that, whenever a template pattern is mentioned or associated with some examples it is given only for reference, since many linguists adopt and/or use it as a morphological property. As demonstrated in the previous chapter and will be emphasised in the consecutive following chapters, the template is not a property of the morphology, but rather it is the outcome of phonological constraints operate on an underlying morphological structure.

### **4.2.1 An Autosegmental Account of the Syllable**

In autosegmental phonology, it is suggested that the phonology consists of several tiers of representation. In each tier the segments are arranged in a linear form. These segments are linked to each other by association lines which show how they are to be coarticulated. Autosegmental phonology was originally introduced to capture the representation of tone in tone languages (Goldsmith, 1976, 1979). Inspired by the work on autosegmental phonology, McCarthy (1979, 1981) extended the notion of

autosegmentation to Semitic languages. He suggested that the syllable in the Semitic languages Arabic and Hebrew is represented in three tiers: the consonantal root tier which hosts the root consonants, the skeletal tier which hosts the template, and the vocalic tier which hosts the vowels. It must be noted that the ordering of tiers represented here is just for illustration. The distribution of consonants and vowels in Arabic is formed by a distinct CV template. Each CV template can distinguish the morphological structure of the word. Thus, the constituent morphemes seem to shape the word rather than just being arranged in a string of subsegments ( McCarthy, 1979; Kenstowicz, 1994; Al-Ageli, 1996, 77). For example, the distinction between a Form I trilateral verb and a Form II trilateral verb is made through the gemination of the C<sub>2</sub> in Form II. The structures of Form I /daras/, ‘he studied’ and Form II /darras/, ‘he caused sb. to study’ are given as follows:

(132)

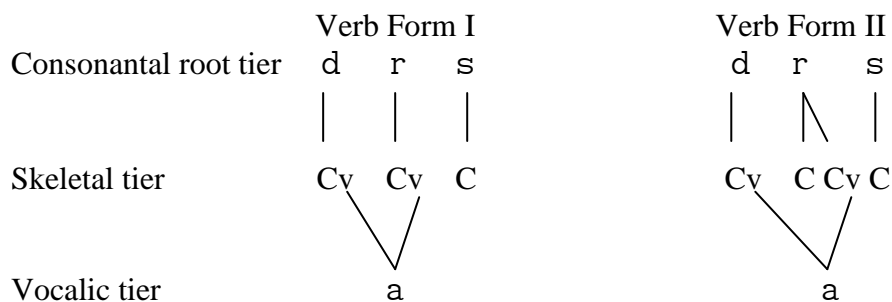

The prosodic shapes of the two verb forms are different. Form II is derived from Form I by geminating the second consonant. The mapping of the elements of the consonantal root tier and the elements of the vocalic tier to the skeleton tier is governed by the universal association convention:

(133) ‘Associate autosegments and autosegment-bearing units one-to-one, left-to-right’  
(Goldsmith, 1976; McCarthy, 1979, 1982).

In the derivational category, the passive and the active forms preserve the same prosodic shape. The difference is only represented in the melodic tier by the change of the vowel quality as in /katab/, ‘he wrote’ active voice, which has the prosodic shape /CvCvC/ and /kutib/, ‘it was written’, passive voice, which has the same

prosodic shape. As can be seen, the active voice is represented by /a/, whereas the passive voice is represented by /u/ and /a/ in the melodic tier. Instead of the explicit CV skeleton, the consonants and the vowels are labelled as Xs (Kaye and Lowenstamm, 1984; Levin, 1985 cited in Watson, 2002, 51). The idea behind introducing X-slots is to optionally associate either a consonant or a vowel in a skeletal position. For example, the representation of a Form III verb, which has the prosodic template /CvVCvC/, for instance /ra:sa1/, ‘to correspond with sb.’, will lead to the mis-association of the second vowel. Thus, mapping the melodic elements to the skeletal tier in one-to-one linking may cause the vowel to be linked to the wrong consonant. The distinction between the templates of Form II and Form III trilateral verbs can be presented in X-slot fashion where the vocalic slots are represented as X-slots before being associated with a nucleus (Nuc) (Watson, 2002, 52):

(134)

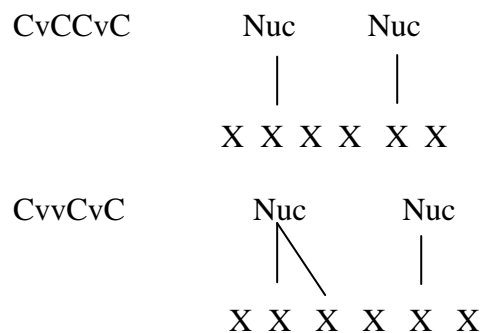

The difference between X-slot and CV association is captured by the fact that the former represents the optionality of phonological weight as far as the rhyme of the syllable is concerned, while the latter cannot identify more than one vowel slot at a time. Thus, the representations of the light (CV) and the heavy (CVV and CVC) syllables based on X-slot theory are given as follows. Form /CV/ syllable has the follow structure:

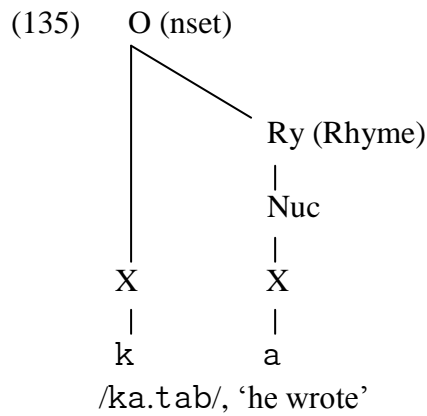

Forms /CvV/ and /CvC/ syllables have the follow structures:

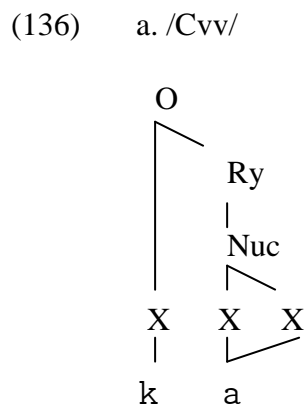

/ka:tiβ/, 'writer'

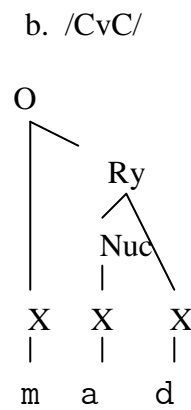

/mad.dad/, 'he extended'

As can be seen in the tree diagrams, the two adjacent vowels in /CvV/ form a single nucleus and they are both directly linked to the nucleus branch. In /CvC/, the vowel is linked directly to the nucleus and the consonant is directly linked to the rhyme branch. Arabic verb forms exhibit a productive process of affixations. The general affixation morphemes are: /ʔ-/ 'causative' in Form IV, /t-/ 'reflexive' in Forms V, VI, VIII-XV, /n-/ in Form VII, and /s-/ in Form X. So far, it is suggested based on the autosegmental approach that there are three morpheme tiers: the vocalic, the consonantal, and the skeletal/prosodic tier. To account for the affixation morphemes, McCarthy (1979) assumed that there is another level of tier representation to host the morpheme affix. Following Spencer (1991, 139), we adopt the Greek letter  $\mu$  to account for any morpheme, whether it is melodic, consonantal, or affixational. The

structure of Form IV and Form VII are given below (see Spencer, 1991, 131-149, for further discussion):

(137) a. Form IV

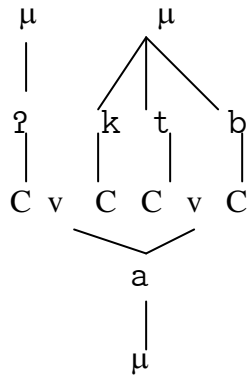

b. Form V

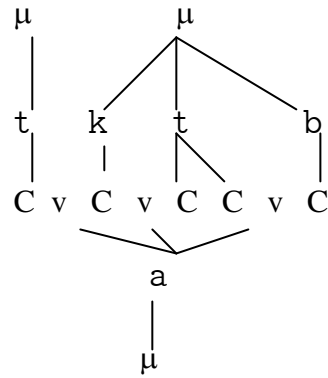

c. Form VI

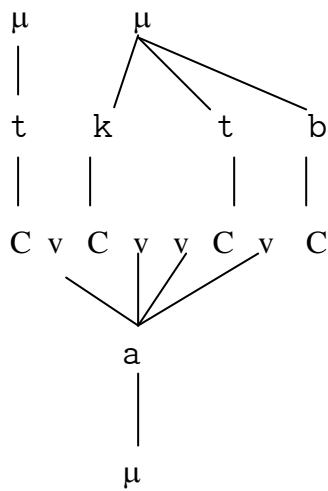

d. Form VII

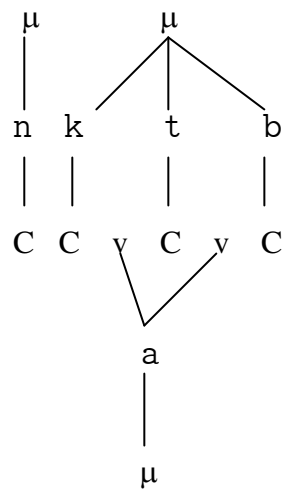

All the affixes in the above tree diagrams are prefixes. However, in Form XIV the morpheme /-n/ is infixational, as represented in the follow tree diagram:



(138) Form XIV

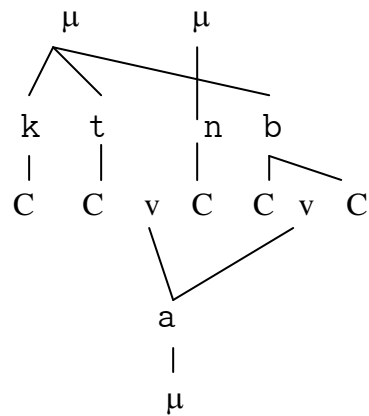

It must be noted that the affix morphemes are associated before the root melody, because if not the first consonant of the triliteral root would be linked to the first C-slot of the prosodic template, and that would consequently blocks affixation (Spencer, 1991, 140).

The reflexive affix /t-/ in Form VIII is infixated inside the stem verb. This creates a problem for the association from left-to-right and one-to-one constraints. McCarthy (1979) introduced a rule called the ‘Eight Binyan Flop’ which dissociates the /t-/ prefix and shifts it one position to the right on the skeleton, that is to say, in the second position of the skeleton:

(139) Eight Binyan Flop

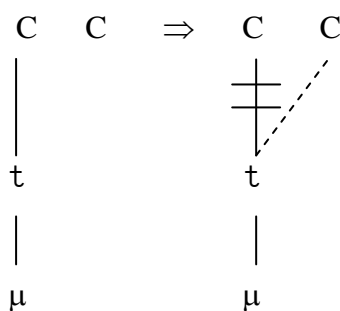

This gives the structure below, where identifying the position of the inserted morpheme takes place before the association of consonants, otherwise the association of the consonants would block the infixation as in Form VIII:

(140) Form VIII

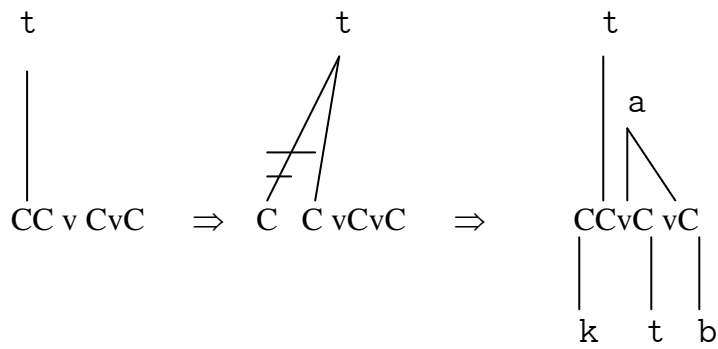

This rule dissociates the infix /t/ and forces it to shift one slot to the right. The other problem is how to account for gemination in Form II and Form V, for example. This requires the delinking of one of the association lines. The Form II and Form V erasure rule are given as follows (adopted from Spencer, 1991, 141):

(141)

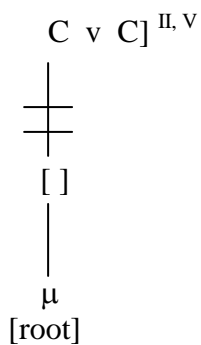

Thus, this rule will give the following structure for Form II:

Erasure Rule for Form II /kat t ab/ 'he caused sb. to write/dictate'

(142)

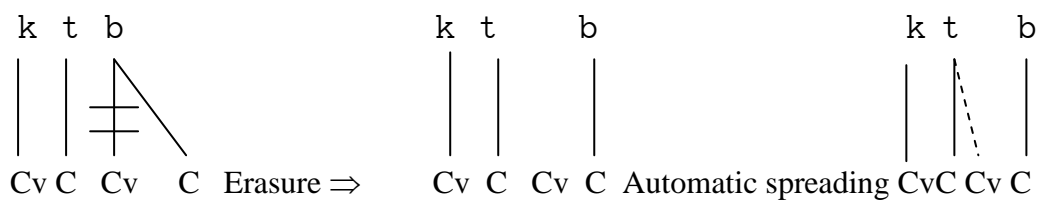

As can be seen, the association link is erased first, then the C-slot is not associated with any link, and finally by autospreading /t/ is spread to fill the empty slot on the right yielding gemination.

McCarthy (1979) also presented an account of the patterns of nouns, and specifically the phenomenon of the patterns of BP in Arabic. Plural formation in Arabic nouns, as discussed earlier in chapter two, is achieved in one of two ways: the first is the formation of SP in which a suffix is attached to the noun; the second is BP which exhibits a change in the Cv skeleton and a change in vowel melody (Spencer, 1991, 142-144). McCarthy (1979) argued that the BP template has the prosodic template structure /CvCv̄vCv (v) C/ where the bracketed vowel depends on the length of the corresponding vowel in the singular noun. Furthermore, the vocalic melody associated with BP is [/a/ and /i/]. The following examples illustrate the prosodic template of BP and how the consonants, vowels, and the plural morpheme are associated to the skeleton template.

(143)            Quadriliteral roots

Singular Form	BP Form
/masbaħ/, ‘swimming pool’	/masa:biħ/, ‘swimming pools’
/misʕba:ħ/, ‘lamp’	/masʕa:bi:ħ/, ‘lamps’

(144)            Quinqueliteral roots

/ʕankabu:t/, ‘spider’	/ʕana:kib/, ‘spiders’
-----------------------	-----------------------

(145)            Trilateral roots

/qa:mu:s/, ‘dictionary’	/qawa:mi:s/, ‘dictionaries’
/xa:tam/, ‘signet-ring’	/xawa:tim/, ‘signet-rings’

Before the association of the consonants and vowels, it can be seen that the last syllable of the BP form is always associated with the vowel /i/. Thus, in the

derivation of the BP, /i/ must be aligned with the rightmost vowel position in McCarthy's account. The quadrilateral nouns will have the following structure:

(146)

a. /masa:biħ/

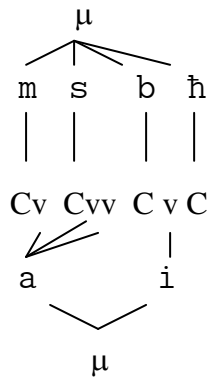

b. /mas<sup>ʕ</sup>a:biħ/

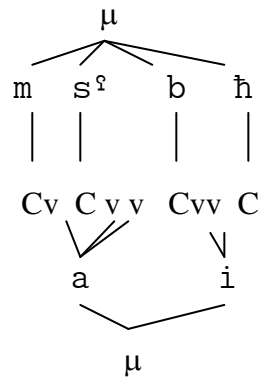

After assigning the vowel /i/ position, the consonants and the vocalic melody are associated left-to-right. The quinqueliteral root reveals that the prosodic template of the BP has only four C-slots. Consequently, one of the root consonants of the singular has to be lost and, since the association is left-to-right, the last consonant remains unassociated as illustrated in the follow diagram:

(147) /ʕankabu:t/

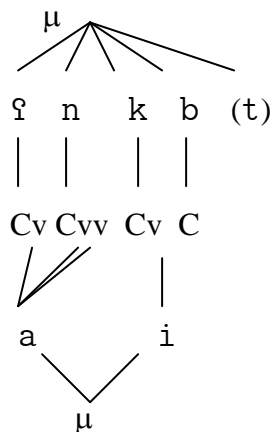

As presented in the tree diagram of /ʕankabu:t/, /t/ is unassociated because there is no C-slot available, thus /t/ is truncated. However, the CA quinqueliteral word

/farazdaq/, ‘a loaf of bread’ is optionally pluralized either by truncating C<sub>4</sub> or C<sub>5</sub> yielding the BP forms /fara:ziq/ and /fara:zid/ respectively.

The BP prosodic template which is derived from a trilateral noun template /CvVCvC/ exhibits the insertion of a glide. This insertion of the glide in the BP template compensates for a corresponding long vowel in the singular noun:

(148) a. /qawa:mi:s/

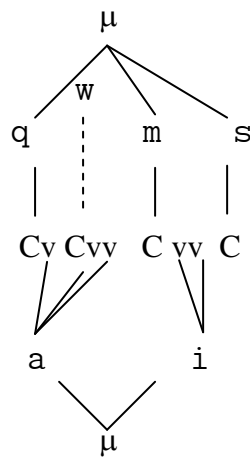

b. /xawa:tim/

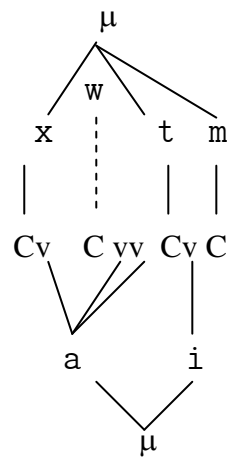

In /qawa:mi:s/ and /xawa:tim/, both plurals show the insertion of the glide /w/ in the second position of the skeleton template. In a normal autosegmental association the second consonant of the consonantal tier is associated with the second consonantal position in the skeleton template, but a rule is provided to insert the glide in its position prior to the spreading of the consonants. Thus, when the glide is infix, it automatically triggers the association between its slot and the root consonants via the rule of automatic delinking (Spencer, 1991, 143).

The diversity of templates and the well-formed prosodic structures associated with such templates can not be justified by phonological processes alone. In fact, this diversity of templates and/or well-formed prosodic structures is accounted for by the different derivational morphemes triggered and associated with different morphological derivational processes. That is to say, the template structure represents phonological processes operating on underlyingly morphological structures. The string of root consonants, sometimes morphological components transferred from the input, and the derivational morpheme supplied by the relevant morphological process

in morphologically specified active morphological sites, construct the underlying structure of the derived word. These are purely morphological processes. However, at the surface level, the phonology repairs any ill-formed structure resulted from the morphological process. Thus, the template is resulted from a syllabification process and other phonological processes, applied on the underlying morphological components.

#### 4.2.2 A Moraic Account of the Syllable

In moraic theory (Hayes and Abad, 1989; Hayes, 1989, 1995), the structure of the syllable is not treated as separated X-slots, but rather the syllable is measured by its weight. Vowels are considered as moraic at the underlying level, where short vowels are linked to one mora and heavy vowels are linked to two moras. Consonants, on the other hand, are considered as underlyingly nonmoraic unless they are geminate. Nevertheless, under language-specific parameters, consonants in the coda position may be recognized as moraic. These languages are said to identify the weight of the syllable by weight-by-position. It must be noted that under moraic theory, onsets play no role in the weight of the syllable. As far as syllable weight is concerned, languages treat syllable weight differently. On the one hand, there are languages that treat /Cv/ and /CvC/ as light and /Cvv/ as heavy; on the other hand, there are languages that treat /Cv/ as light and /CvC/ and /Cvv/ as heavy. Although consonants in the coda position are marked either as moraic or nonmoraic based on language-specific preference, short vowels under moraic theory are linked with one mora, and prolonged vowels are linked with two moras. The representation of syllables based on moraic weight is as follows:

(149)

a. Light syllable

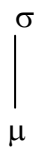

b. Heavy syllable



Light syllables are considered as monomoraic, whereas heavy syllables are considered as bimoraic represented as follows:

(150)

a. Monomoraic syllables

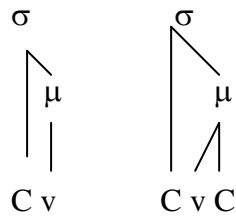

b. Bimoraic syllables

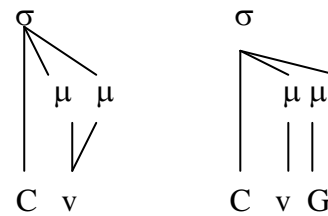

The vowel of the monomoraic syllable /Cv/ is linked to one mora, and similarly in /CvC/ both the vowel and the consonant are linked to one mora, since consonants are underlyingly treated as nonmoraic. In the bimoraic syllable, (G) stands for geminate consonants; the syllable /CvG/ is considered as bimoraic where the vowel and the consonant are linked to different moras. The long vowel of the bimoraic syllable /Cvv/ is linked to two moras.

Following Watson's (2002, 54-55) justification, moraic analysis is here favoured over X-slot analysis for the following reasons. In X-slot theory, every segment is given equal rank regardless of weight, whereas moraic theory accounts for the prosodic weight of the syllable where only segments that bear weight are given status. Unlike X-slot theory, which does not group segments, moraic theory reveals the closely interaction between the weight of the syllable and the assignment of stress. Moraic theory gives an economical explanation for phonological process such as compensatory lengthening (Hayes, 1989). Watson gives an example of the historical change of the Cairene Arabic word /ra:s/, 'head' which is /raʔs/ in CA. This historical change also exists in LA. The glottal stop is deleted and is compensated for by lengthening the vowel. Under moraic theory, the glottal stop is first disassociated and then the vowel spreads to fill the empty mora position which is left behind by the glottal stop. However, in X-slot theory, this process is achieved in many steps; first deleting the consonant completely from the X-slot, the X is disassociated from the coda position, and then, thirdly, X is reassociated with the nucleus position (Watson, 2002, 55).

### 4.2.3 Syllable Structure in OT

In OT (McCarthy and Prince, 1993a, 1995, 1999; Prince and Smolensky, 1993, 2004a), it is assumed that Universal Grammar provides a set of violable constraints on syllable structure, and each language ranks these constraints based on language specific parameters. There are two conflicting types of constraints of markedness and faithfulness. Markedness constraints militate against any ill-formed syllable structure and faithfulness constraints require segmental faithfulness. It has been widely adopted that the basic unmarked syllable structure is CV (Jacobson, 1962; Clements and Keyser, 1983). OT introduces two markedness constraints and two faithfulness constraints to account for the universal syllable structure. The universal markedness constraints are ONSET and \*CODA, and the universal faithfulness constraints are MAX-IO and DEP-IO. The statements of these constraints are given as follows:

ONSET: A syllable must have an onset.

\*CODA: A syllable must not have coda.

MAX-IO: Every segment of the input has a correspondent in the output.

DEP-IO: Every segment of the output has a correspondent in the input.

The two types of constraints are not restricted to correspondence input-output mapping, but can also be of the O-O correspondence type ( see, McCarthy and Prince, 1995; Benua, 1995, 1997; McCarthy, 1997), among others).

Based on the OT mechanism, GEN will generate a large number of syllable candidates and EVAL will cross-check them with the constraints hierarchy of the language, and based on that the optimal candidate is chosen. To see how the two markedness constraints interact together, consider the tableau below:

(151)

Input: [CvCv]	*CODA	ONSET
a. → /Cv.Cv/		
b. /CvC.v/	*!	*!

The dots in the outputs show syllabification. The tableau shows that candidate (a)



satisfies both constraints, while (b) violates both because in the first syllable it has a coda and in the second it lacks an onset.

Segment preservation by the two conflicting faithfulness constraints is illustrated in the tableau:

(152)

Input: [CvCv]	MAX-IO	DEP-IO
a. → /Cv.Cv/		
b. /Cv.CvC/		*!

Since preserving the exact segments is favoured over any added segments, candidate (b) loses because the added consonant violates the higher ranked constraint MAX-IO.

The following section introduces syllable structure and syllabification in LA based on OT.

### 4.3 Syllable Structure and Syllabification in LA

#### 4.3.1 Syllable Patterns in LA

Abumdas (1985, 89) reported thirteen syllable patterns in LA (the Tripoli, Zlitan, and Benghazi varieties) as presented in the table below.

(153) Syllable Patterns in LA identified by Abumdas (1985):

Syllable Pattern	Example	Gloss
1- v	/a.be/	'he agreed'
2- vv	/u:ɡuf/	'stop'
3- vC	/as.wad/	'black'
4- vvC	/i:h/	'yes'
5- Cv	/ki.tab/	'he wrote'
6- Cvv	/ka:tib/	'writer'
7- CvC	/man/	'Who?'
8- CvCC	/kalb/	'dog'
9- CvvC	/t <sup>ʕ</sup> u:l/	'length'
10- CCv	/yt <sup>ʕ</sup> a/	'cover'
11- CCvvC	/kta:b/	'book'
12- CCvCC	/lbist/	'I wore'
13- CCvC	/smin/	'he became fat'

Elgadi (1986, 57) accounted for a further two syllable types which he claimed exist in the Tripoli Dialect (TD). These syllables have triconsonantal onset clusters. They are /CCCv/ as in /nkwe/, 'to be cauterized' and /CCCvC/ as in /l tħam/, 'it was welded'.

Looking at the fifteen syllable patterns which represent all the possible types in LA, it is clear that the nucleus is always represented by; either a short or long vowel. The onset may consist of no consonant or up to three consonants, while the coda may consist of no consonant and maximally two consonants. In Abumdas' account, an initial vowel syllable is permitted, at least underlyingly; however, in TD it is not allowed (Elgadi, 1986, 59).

The triconsonantal cluster claimed by Elgadi for TD was questioned by Al-Ageli (1996, 112). These types of syllables exhibit the insertion of a morphological prefix or

infix, and this is usually the case for the verbs to which they are attached; for example, /t/, /n/ or the preposition /l/. In his account, Elgadi assumed that no pre-stem epenthesis occurs in such cases. He introduced a vowel insertion rule to break up the triconsonantal clusters stem-internally (Elgadi, 1986, 69), and thus /ktabt+l+hum/, (I wrote + preposition + them) meaning ‘I wrote to them’ becomes /ktabt+i.l+hum/ where the triconsonantal cluster is broken up by the epenthetic /i/ (Al-Ageli, 1996, 112).

The occurrence of superheavy syllables and those with an additional consonant linked to a branching rhyme are restricted to the word final-position (Al-Ageli, 1996, 113). This type of superheavy syllable usually occurs at word boundaries or occur as a result of a phrase-level syllabification ( McCarthy, 1979; Al-Ageli, 1996):



[φ] = phonological phrase, (X) = can be a vowel or a consonant

McCarthy (1979, 10-11) claimed that in CA the heavy syllables /CvVC/ and /CvCC/ are positioned at the end of a phonological phrase. The tree diagram above refers to the phrase-final consonant which is adjoined to a preceding syllable. In later studies, McCarthy and Prince (1990a; 1990b) suggested that any consonant at the periphery is considered as extrametrical. In the tree diagram, the rightmost consonant of the stem which occurs in a coda position in a superheavy syllable is considered as an extrametrical syllable node. This vowelless syllable is considered to be the onset of an unparsed syllable. Extrametricality is not restricted to rightmost stems, but is also introduced to syllabify the leftmost stems. Since Arabic does not prefer onset clusters, these are seen as unsyllabified segments.

### 4.3.2 Syllable Structure and Syllabification in LA

In the previous table, the syllable patterns 1-4 in LA occur syllable-initially and they underlyingly lack onsets. Onsets are inserted at the surface level, because vowel-initial syllables are not allowed in LA. The typical mode of syllable repair in these cases is to insert the glottal stop /ʔ/ to fill the empty onset. Pattern 1 is not common. The long vowel in Pattern 2 is at the underlying level represented as the glide /w/ which occupies C<sub>1</sub>. Pattern 3 is always associated with adjectives of colour and defect. Pattern 4 only occurs in the following examples:

(155) a. /v/ as in /a.be/ ‘he agreed’

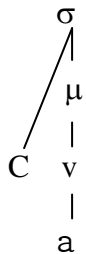

b. /vv/ as in /u:.guf/ ‘Stop!’

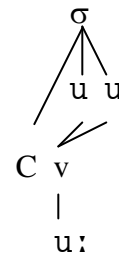

c. /vC/ as in /as.wad/ ‘black’



d. /vvC/ as in /i:h/ ‘yes’



An example shows how OT can deal with the empty onset is given below:

(156)

Input: [abe]	ONSET	DEP-IO
a. → /ʔa.be/		*
b. /a.be/	*!	

The tableau shows the interaction between a markedness constraint and a faithfulness constraint. Candidate (a) is not faithful to the input because of the added segment, but

the higher ranked markedness constraint which militates against onsetless syllables chooses it as optimal. In LA, a syllable at the surface level must always have an onset. The absence of onsets in the syllable structures given above is related to the fact that these structures represent the underlying structures of these syllables. Another reason for onsetless syllables is due to a constraint that forces glides in the initial onset position to surface as long vowels, as in /u:.guf/ in which the initial vowel is the surface realization of the glide /w/.

The following monomoraic syllable is the minimal syllable pattern in LA in general. This syllable is obligatorily filled by a consonant and a vowel:

(157) /Cv/ as in /ka.ta.b/

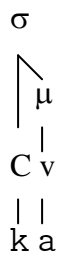

When it is in the stem-final position the pattern /CvC/ is considered light. However, if it occurs word-internally it may be subject to receiving stress, as in /ka.ta.b.ha/, ‘he wrote it’, and thus, in this case this pattern is considered heavy:

(158) a. /Cvv/ as in /ka:.tib/, ‘writer’

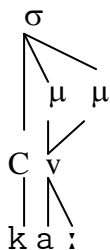

b. /CvC/ as in /man/, ‘Who?’



Patterns /CvvC/ and /CvCC/ are considered super heavy syllables since they consist of two moras plus an additional consonant:

(159) a. /Cv̥vC/ as in /t̥u:l/, ‘length’

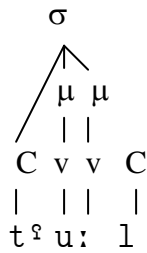

b. /CvCC/ as in /kalb/, ‘dog’



Pattern /Cv̥vC/ is restricted to the word-final position of the phonological phrase as in /ʔiʒ.ba:l/, ‘mountains’ plural, and SP suffixes as in /mu.ʔal.li.mi:n/, ‘teachers’ masculine + plural, and /mu.ʔal.li.ma:t/, ‘teachers’ feminine + plural. In both patterns, the last consonants are not considered as extrametrical, but rather as extrasyllabic since they are not incorporated into the adjacent syllable at any stage in the derivation (Selkirk, 1981; Kager, 1995; Watson, 2002). Now, consider the syllables that exhibit margin clusters:

(160) a. /CCv/

[ɣit̥ɑ:ʔ] ⇒ /yt̥ɑ/, ‘cover’

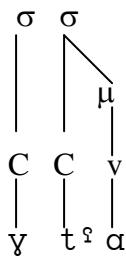

b. /CCv̥vC/

[kita:b] ⇒ /kta:b/, ‘a book’

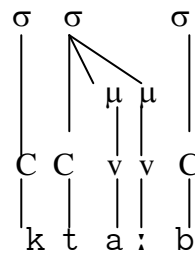

(161) a. /CCvCC/

[labist̥] ⇒ /lbist̥/, ‘I wore’

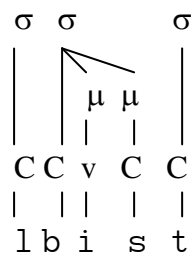

b. /CCvC/

[samɪn] ⇒ /smin/, ‘he became fat’

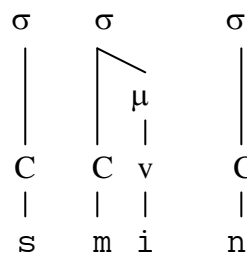

c. /CCCv/

[n̂kawɣ] ⇒ /nkwe/, ‘to be cauterized’

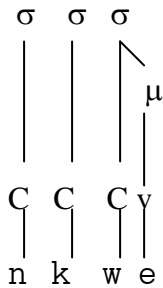

d. /CCCvC/

[l̂t̂aħam] ⇒ /ltħam/, ‘it was welded’

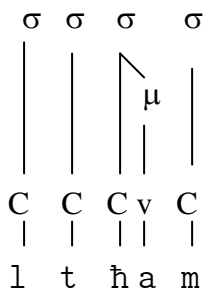

Pattern /CCv/ is derived from the triliteral defective root verb /y,t̂,j/ where the glide shows up firstly as a long vowel /a:/ and secondly it undergoes shortening. Pattern /CCvvC/ is underlyingly represented as /CvCvvC/, but the short vowel is lost creating an initial onset cluster. The first consonant cluster is considered extrametrical, which becomes the coda of an unparsed syllable. The onset of this unparsed syllable is filled with a glottal stop at the surface level. Pattern /CCvCC/ is at the underlying level represented as /CvCvC+C/, and the onset cluster is the result of deleting the short vowel in the open syllable, while the coda cluster is the result of attaching the first singular object pronoun /t̂/ to the stem verb. Both consonants at the periphery are considered extrametrical. Pattern /CCvC/ is at the underlying level represented as /CvCvC/; it seems that short vowels in open syllables are subject to deletion when they are unstressed. The patterns /CCCv/ and /CCCvC/ exhibit

triconsonantal onset clusters. These patterns are claimed by Elgadi (1986, 57) to exist in TD. It seems that they may be underlyingly represented as clusters, but at the surface level these sequences of consonants require a rule of vowel epenthesis to break them up (Elgadi, 1986; Al-Ageli, 1996).

### 4.3.3 Semisyllables in LA

The words represented in the follow examples exhibit two phonological processes related to the syllable structure. The first is a superheavy syllable of the pattern /CvvC/ and /CvCC/, and the second is the onset cluster as in /CCvvC/. The onset cluster is the result of deleting a high short vowel in an open syllable. This onset cluster is resolved by an epenthetic vowel and a glottal stop in the surface structure. The deletion of a short vowel also occurs after geminates, as in /muʔallimi:n/, ‘teachers’ ⇒ /muʔallmi:n/. This deletion also creates a superheavy syllable /CvCC/ in a word-medial position. The superheavy syllables exceed the maximum weight of the syllable allowed in LA which restricts it to being maximally bimoraic. The unsyllabified mora of the superheavy syllable in the final position is considered as extrametrical. However, the occurrence of a superheavy syllable word-medially creates a trimoraic syllable. Since syllables are maximally bimoraic, the third mora of the superheavy syllable cannot be parsed by the syllable. Kiparsky (2003, 5) suggested that this extra unsyllabified mora is adjoined to the prosodic word. He identified the unsyllabified mora of the superheavy syllable as a semisyllable. The licening of semisyllables takes place only at the word level. The examples below illustrate the structure of superheavy syllables:

- (162) /gɑ:l.ha/, ‘he said it’  
 /jɪsr.gu/, ‘they steal’  
 /n.hɑ:r/, ‘rivers’  
 /ʔaʒ.r/, ‘reward’

These words can be taken forward and put in a representation of a prosodic hierarchy. The representation presupposes two claims: firstly, moras must be parsed by syllables



(Selkirk, 1981); and secondly, every mora must be assigned to a higher-level prosodic constituent (Ito, 1986, 1989). In the tree diagrams, moras are arranged according to a bimoraic weight to form syllables. Any mora that fails to fulfil the bimoraicity requirement is attached directly to the prosodic word. Although the foot is higher in the prosodic hierarchy than the syllable, an unparsed segment cannot be attached to the foot since the latter itself requires foot binarity. Thus, the next higher prosodic rank is the prosodic word which does not have restrictions on weight size. In /gɑ:l.ha/, the mora /l/ is left unparsed by the syllable; consequently, it is directly attached to the prosodic word. Similar to this, in /j i s r .g u/, the unparsed mora /r/ is attached to the prosodic word. In /n.hɑ:r/, there are two unparsed moras. The first is /n/ which creates an onset cluster, and the second is /r/ in the final position which is considered as an extrametrical unsyllabified onset. Both of these unparsed moras are linked directly to the prosodic word. In /ʔaʒ.r/, /r/ is an extrametrical mora linked to the prosodic word:

(163)

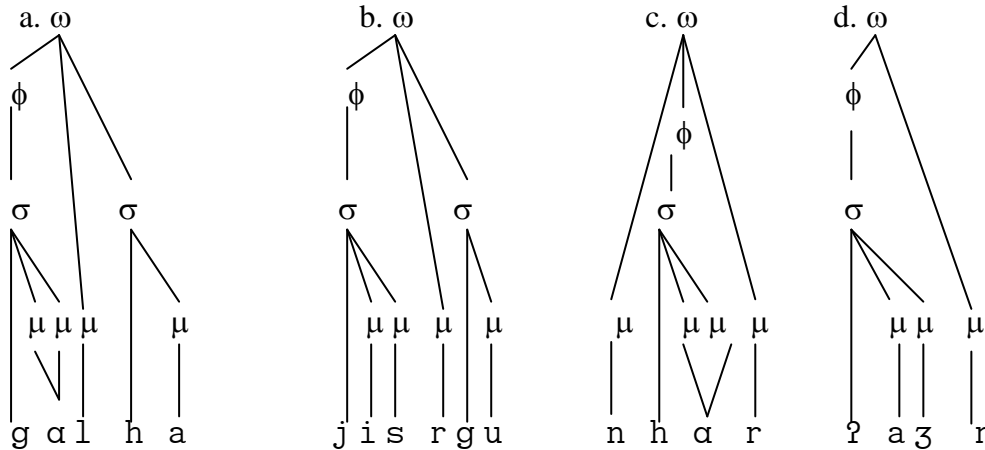

Let us take (163-a) as an illustrating example and see how it can be developed in an OT account. In /gɑ:l.ha/, there are two metrical constraints at work; FOOT-BIN which requires a syllable to be bimoraic; and second LICENSE-<sub>μ</sub> which allows a third mora, which is /l/, to be parsed as a semisyllable. To avoid the loss of a mora, we also need the constraint MAX-<sub>μ</sub>. The statements of the constraints are as follows:

LICENSE-<sub>μ</sub> : All moras must be licensed by syllables, (Kiparsky, 2003).

FOOT-BIN: Feet are binary under moraic or syllabic analysis. (Prince, 1980; Kager, 1989; Prince and Smolensky, 1993)

MAX- $\mu$ : All moras of the input must be preserved.

(164)

Input: [gɑ:lha]	*Cv] $\sigma$	MAX- $\mu$	LICENSE- $\mu$	FOOT-BIN
a. $\rightarrow$ (gɑ:l) $\downarrow$ $\mu$ .ha				*
b. (gɑl).ha		*!		
c. (gɑ:).li.ha	**!			

The tableau shows that candidates (c) and (b) follow different strategies to syllabify /l/. In (c) /l/ is syllabified by creating an open light syllable, while in (b) /l/ is attached to the first syllable creating a heavy syllable /CVC/ but at the cost of deleting a mora. Thus, both candidates are ruled out by the high-ranked constraints \*Cv] $\sigma$  and MAX- $\mu$  respectively. The optimal candidate (a) only violates FOOT-BIN. However, this constraint is outranked by LICENSE- $\mu$ , which allows /l/ to be parsed to the prosodic word directly, and so candidate (a) wins.

#### 4.4 Phonotactics of LA

##### 4.4.1 Consonant Clusters

Consonant clusters refer to a string of consonants uninterrupted by vowels. Such a string consists of two or more consecutive consonants. Consonant clusters can be found in initial, medial or final positions in all LA dialects. They may be found across the word boundary, across the morpheme boundary, or within a word (Abumdas, 1985, 65).

#### 4.4.1.1 Initial Position

An initial consonant cluster is the result of syncopating an unstressed initial light syllable. The below examples represent a cluster within the stem:

(165)	Underlying Form	Surface Form
	/ʕɑrɑf/, ‘he knew’	/ʕrif/
	/kila:b/, ‘dogs’	/kla:b/
	/duʕa:ʔ/, ‘calling’	/dʕe:/

It is quite common in LA that unstressed open light syllables lose their short vowels, creating a string of consecutive consonants. Levy observed that, in CA, surface pattern /ʔaCCa:C/ can be derived from underlying /CaCa:C/ by a rule called by McCarthy and Prince the /Ca/ metathesis rule (Levy, 1971; McCarthy and Prince, 1990b). McCarthy and Prince (1990b) also claimed that the underlying structure for the BP trochaic patterns /CaCuC/, /CaCiC+ at/, and /CaCiCa:ʔ/ surface as /ʔaCCuC/, /ʔaCCiCat/, and /ʔaCCiCa:ʔ/ respectively. Furthermore, the relative adjective /CvCvC/ surfaces as /ʔaCCaC/, as in /kabar/ ⇒ /ʔakbar/, ‘greater; greatest’ (McCarthy and Prince, 1990b, 279). Similarly, the imperative can be claimed to follow the same path. However, it might be the case that avoiding open light syllables and stress assignment play the main roles in the so-called /Ca/ metathesis, which is very obvious in LA. There are many exceptions to these consonant clusters within the stem. In the examples below there is no loss of vowels in both forms in SD, for example:

(166)	/ʕinab/, ‘grapes’	/ʕanab/
	/daʒa:ʒ/, ‘chicken’	/daʒa:ʒ/
	/ʒami:l/, ‘beautiful’	/ʒami:l/

However, in Tripoli Dialect, these words are subject to initial consonant clusters (Abumdas, 1985). Nonetheless, taking an example from SD can show how the light unstressed syllable is treated in the environment of a neighbouring heavy syllable.

This example /kila:b/ ‘dogs’ ⇒ /ʔikla:b/ presented in the follow table accounts for both the avoidance of unstressed light syllables as well as the avoidance of consonant clusters:

(167)

Input: [kila:b]	*[Cv] <sub>σ</sub>	ONSET	*COMPLEX	DEP-IO
a. → /ʔik.la:b/				*
b. /kla:b/			*!	
c. /ik.la:b/		*!		
d. /ki.la:b/	*!			

Candidate (d) is faithful to the input and does not violate the other constraints. It satisfies \*COMPLEX by avoiding clusters. It satisfies ONSET, and also satisfies DEP-IO by not gaining any additional segments. However, it violates the higher ranked constraint \*[Cv]<sub>σ</sub>, which militates against any unstressed open light syllable. Candidate (c) lacks an onset so it is ruled out by ONSET. Because of its onset cluster, candidate (b) commits a violation of the constraint \*COMPLEX. The optimal candidate (a) satisfies all the three markedness constraints, but violates the faithfulness constraint DEP-IO by creating a new syllable where the unsyllabified mora is positioned as coda. Candidate (a) is not faithful to the input since the glottal stop of the output has no correspondent in the input. But, since DEP-IO is low ranked, candidate (a) wins.

#### 4.4.1.2 Across the Morpheme Boundary

In cases where the prefix is occupied by an inflectional morpheme or where C<sub>1</sub> and C<sub>2</sub> are bilabial, then the vowel of the first open syllable of the word is syncope to create a string of two clusters (Abumdas, 1985, 69):

(168)	/na+limm/, ‘I gather’	/nlimm/
	/ta+bi:ʔi/, ‘you sell’ fem.	/tbi:ʔi/
	/mafa:ti:h/, ‘keys’	/mfa:ti:h/
	/mawɑ:ʔi:d/, ‘promises’	/mwɑ:ʔi:d/

Consonant clusters can also be the result of prefixing a preposition or prefixing a derivational morpheme:

/bi+ ru:ħah/, ‘by himself’	/bru:ħah/
/mu+ ʒa:hid/, ‘fighter’	/mʒa:hid/

All these prefixes undergo three syllabification processes. In the first, the prefix preserves its light syllable attached to the stem word. In the second, such a light syllable is unstressed, and thus loses its short vowel to create a complex onset. Then, the first onset of the cluster is resyllabified as a coda in a new closed syllable headed by an epenthatic glottal stop.

#### 4.4.1.3 Medial Position

The following examples show medial clusters within the stem and across boundaries:

(169)	/sariqa/	/sirga/, ‘theft’
	/samiʕat/	/simʕat/, ‘she listened’
	/bint+i/	/binti/, ‘my daughter’
	/m+ CvCvC/	/maktu:b/, ‘fate/written’
	/m+ t+ CvCCvC/	/mitmakkin/, ‘skilful’
	/m+ CvCvC/	/mudnib/, ‘guilty’
	/CaCCaC/	/ʕaskar/, ‘soldiers’

In these examples, the loss of the short vowels and the creation of medial clusters are attributed to the shift of the stress. Nevertheless, each consonant of the cluster is maintained by a distance governed by the syllable boundary.

#### 4.4.1.4 Final Position

Within the stem, final double consonants are allowed in three conditions: when they are constrained by a fall of sonority sequence; when C<sub>1</sub> and C<sub>2</sub> form the trilateral

noun/verb are identical; or when the inflectional suffix is the first subject pronoun. This is true in a pause; however, in continuous speech or across morpheme boundaries the second consonant of the cluster may be positioned in a new syllable:

- (170)        /bɑrg/, ‘lightening’  
               /nidd/, ‘counterpart/equivalent’  
               /katɑbt/, ‘I wrote’

In the examples above, the coda clusters are the result of either the falling sonority of segments or identical geminated segments. These sonority sequences cannot be interrupted by any epenthetic vowel. The markedness constraint representing the sonority sequence is defined as follows:

SON-SEQ: Complex onsets rise in sonority, and complex codas fall in sonority, (Clements, 1990).

(171)

Input: [bɑrg]	SON-SEQ	DEP-IO
a. → /bɑrg/		
b. /bɑ.rɑg/		*!

In order to preserve the sonority sequence, the SON-SEQ constraint must outrank DEP-IO which militates against epenthesis. Thus, candidate (b) loses because of the epenthetic vowel that breaks the string of the coda cluster. Candidate (a) wins since the falling sonority of the consonant cluster is respected.

#### 4.4.2 Glides Distribution

In CA as well as LA, glides are considered root consonants at the abstract level of root consonants representation. In derivational and inflectional morphology, glides are subject to phonological processes such as surfacing as consonantal or vocalic, deletion, and change of features. In this section, an overview of the states of glides and the related morphophonological constraints that motivate the glides to surface are

presented. Since our focus here is to account for non-concatenative derivational morphology of the nominal system, the implications of this section will be put forward to account for the surface structure of glides as a consequence of interaction between phonology, represented by the active phonological constraints, and the morphology, represented by the underlying morphological structure of the derived word

Generative linguists do not distinguish between high vowels and glides based on feature distinctions. They assume that the only difference is glides are syllabic while high vowels are not (Chomsky and Morris, 1968). At a later stage, the distinction was comprehended based on the theory of the syllable (Selkirk, 1982, 1984; Clements and Keyser, 1983; Kaye and Lowenstamm, 1984; Levin, 1985). In this theory, vowels occupy the nucleus of the syllable while glides occupy the periphery margins at onset or coda. The realization of vowels and glides based on syllable structure is as follows:

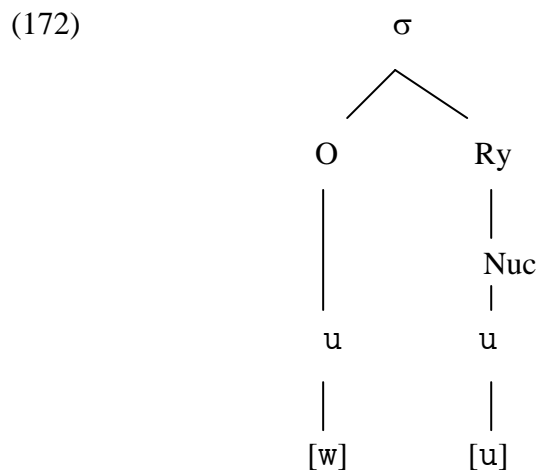

Furthermore, it has been assumed that high vowels such as [i,u] have identical feature to [j,w]. The only difference is glides are considered as the nonsyllabic realization of vowels (Padgett, 2008). In other words, glides and vowels share V-place nodes, but the difference between them is in identifying the feature [consonant]. Consider the follow representation:

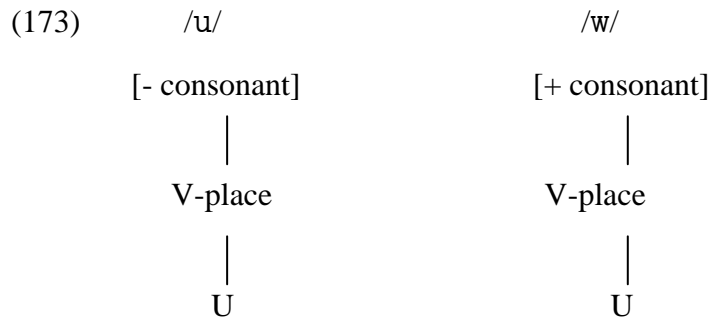

Because of the feature [consonant], the high vowel /u/ is identified as a nucleus and the glide /w/ as a margin. In Arabic, glides alternate with high vowels but high vowels do not alternate with glides (Rosenthal, 2006, 408). The vocalic features assumed here, following Rosenthal, are {I} = [i], {U} = [u], and {A} = [a], and mid-vowels from the combination of {I, A} = [e] and {U, A} = [o] (Rosenthal, 2006 based on Schane, 1984; Kaye, 1989).

In moraic phonology theory, glides are linked directly to a syllable node while vowels are linked directly to a mora (Hyman, 1985; McCarthy and Prince, 1986; Hayes, 1989). The realization of vowels and glides based on moraic structure is as follows:

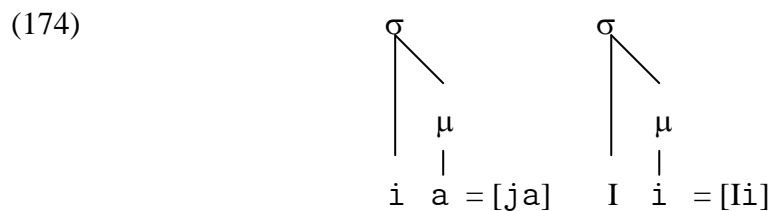

In Arabic glides can delete, surface, or vocalize, and thus these phonological alternations lead in varieties to surface structure of the stems. In the phonology of LA nouns, underlying diphthongs surface as monophthongs. Consider the follow varieties:

(175) Underlying Form	Surface Form
/ʔ <sub>1</sub> i <sub>2</sub> d <sub>3</sub> /, ‘festival’	/ʔ <sub>1</sub> i : d <sub>3</sub> /
/k <sub>1</sub> aw <sub>2</sub> x <sub>3</sub> /, ‘hut’	/k <sub>1</sub> u : x <sub>3</sub> /
/b <sub>1</sub> aw <sub>2</sub> b <sub>3</sub> /, ‘door’	/b <sub>1</sub> a : b <sub>3</sub> /
/j <sub>1</sub> aw <sub>2</sub> m <sub>3</sub> /, ‘day’	/j <sub>1</sub> o : m <sub>3</sub> /



/ʔ<sub>1</sub>a.j<sub>2</sub>b<sub>3</sub>/, ‘shame/fault’

/ʔ<sub>1</sub>e : b<sub>3</sub>/

The interesting thing about the position of the glide in monosyllabic stems is that each glide in the underlying form is preceded by a short vowel and followed by a consonant. The surface forms of the glides as monophthongs indicate that they are parsed as moras. Putting them into constraint interactions, it is clear that there are two constraints at work. The first is a markedness constraint and the second is a faithfulness constraint. The markedness constraint militates against the existence of glides as consonants and the faithfulness constraint requires identity with the input. The two constraints are given below to account for the surface form /ʔ<sub>1</sub>i : d<sub>3</sub>/:

NO-DIPH : No syllable contains a bivocalic nucleus.

IDENT-IO : Correspondent segments in input and output have identical values.

(176)

Input: [ʔ <sub>1</sub> i.j <sub>2</sub> d <sub>3</sub> ]	NO-DIPH	IDENT-IO
a. → /ʔ <sub>1</sub> i : d <sub>3</sub> /		*
b. /ʔ <sub>1</sub> i.j <sub>2</sub> d <sub>3</sub> /	*!	

The faithful candidate /b/ violates the higher ranked markedness constraint NO-DIPH which militates against the surface appearance of a diphthong. The optimal candidate (a) parses the diphthong as a monophthong, and thus it avoids the violation of the markedness constraint.

The diphthong /aw/ in the input /k<sub>1</sub>aw<sub>2</sub>x<sub>3</sub>/ surfaces as a long vowel /u :/ in the output /k<sub>1</sub>u : x<sub>3</sub>/. The constraints involved here are a set of MAX-IO [FEATURE] constraints.

They are defined as:

MAX- {U} : Every feature of {U} in S<sub>1</sub> has a correspondent in S<sub>2</sub>.

MAX- {A} : Every feature of {A} in S<sub>1</sub> has a correspondent in S<sub>2</sub>.

(177)

Input: [k <sub>1</sub> aw <sub>2</sub> x <sub>3</sub> ]	NO-DIPH	MAX- {U}	MAX- {A}
a. → /k <sub>1</sub> u : x <sub>3</sub> /			*
b. /k <sub>1</sub> a : x <sub>3</sub> /		*!	
c. /k <sub>1</sub> aw <sub>2</sub> x <sub>3</sub> /	*!		

Although it does not violate the MAX-Feature constraints, candidate (c) is ruled out by the active language-specific constraint NO-DIPH. Since MAX- {U} dominates MAX- {A}, candidate (a) /k<sub>1</sub>u : x<sub>3</sub>/ becomes optimal.

The only difference between /k<sub>1</sub>aw<sub>2</sub>x<sub>3</sub>/ ⇒ /k<sub>1</sub>u : x<sub>3</sub>/ and /b<sub>1</sub>aw<sub>2</sub>b<sub>3</sub>/ ⇒ /b<sub>1</sub>a : b<sub>3</sub>/ is the ranking of the MAX-FEATURE constraints. The ranking in the first form is that MAX- {U} >> (dominates) MAX- {A}, whereas in the second MAX- {A} >> MAX- {U}.

In the tableau below, the undominated constraint NO-DIPH rules out the faithful candidate (c). The optimal candidate (a) satisfies MAX- {A} although it violates MAX- {U}. But since MAX- {A} >> MAX- {U}, candidate (b) loses and candidate (a) wins.

(178)

Input: [b <sub>1</sub> aw <sub>2</sub> b <sub>3</sub> ]	NO-DIPH	MAX- {A}	MAX- {U}
a. → /b <sub>1</sub> a : b <sub>3</sub> /			*
b. /b <sub>1</sub> u : b <sub>3</sub> /		*!	
c. /b <sub>1</sub> aw <sub>2</sub> b <sub>3</sub> /	*!		

Candidate (d) in the follow tableau represents /j<sub>1</sub>aw<sub>2</sub>m<sub>3</sub>/ which is ruled out by the higher ranked constraint NO-DIPH. The interaction between MAX- {U} and MAX- {A} does not predict the optimal candidate. Their interaction results in forms (b) /j<sub>1</sub>u : m<sub>3</sub>/, and (c) /j<sub>1</sub>a : m<sub>3</sub>/. Thus, their ranking plays no role here. The actual optimal output is (a) /j<sub>1</sub>o : m<sub>3</sub>/ which surfaces with a homorganic mid-vowel. Neither the feature high {U} nor low {A} alone succeed in being expressed in the optimal output. The surfacing of the mid-vowel is the result of the derivational combination of features. The combination of the features {U, A} produces the mid-vowel [o] and the combination of {I, A} results in the mid-vowel [e] (Rosenthal, 2006, 408). In this case, the string of /aw/ surfaces as /o/. The markedness constraint COMBINE {U, A}

chooses the winner (a) since both outputs (b) and (c) fail to do so. The markedness constraint is defined as:

COMBINE {U, A}: Combine the features of {U} with the features of {A}.

(179)

Input: [j <sub>1</sub> aw <sub>2</sub> m <sub>3</sub> ]	NO-DIPH	COMBINE {U, A}	MAX- {U}	MAX- {A}
a. → /j <sub>1</sub> o : m <sub>3</sub> /			*	*
b. /j <sub>1</sub> u : m <sub>3</sub> /		*!		*
c. /j <sub>1</sub> a : m <sub>3</sub> /		*!	*	
d. /j <sub>1</sub> aw <sub>2</sub> m <sub>3</sub> /	*!			

Similar to the argument for /j<sub>1</sub>aw<sub>2</sub>m<sub>3</sub>/ ⇒ /j<sub>1</sub>o : m<sub>3</sub>/ but with a difference in feature combination, the optimal candidate in (a) /ʔ<sub>1</sub>e : b<sub>3</sub>/ wins because the constraint COMBINE {I, A} outranks both MAX-FEATURE constraints, as represented in the follow tableau:

(180)

Input: [ʔ <sub>1</sub> aj <sub>2</sub> b <sub>3</sub> ]	NO-DIPH	COMBINE {I, A}	MAX- {I}	MAX- {A}
a. → /ʔ <sub>1</sub> e : b <sub>3</sub> /			*	*
b. /ʔ <sub>1</sub> i : b <sub>3</sub> /		*!		*
c. /ʔ <sub>1</sub> a : b <sub>3</sub> /		*!	*	
d. /ʔ <sub>1</sub> aj <sub>2</sub> b <sub>3</sub> /	*!			

As we have seen, diphthongs in the medial position in the monosyllabic syllable pattern /CvGC/ (G= glide) surface as homorganic long vowels. However, if a diphthong occurs in the final position it might be preserved, as in the following examples:

- (181) /ʒaw/, ‘weather/mood’  
 /zaj/, ‘dress/as’

The preservation of the diphthong in the final position is related to the fact that stems (nouns and verbs) in Arabic are consonant-final (McCarthy and Prince, 1990a,

1990b). The condition of being consonant-final is related to the suffix and not to the stem in the case a suffix augmented to a stem. This is due to a constraint on the suffix that forbids a syllable peak preceding a suffix (Rosenthal, 2006). Rosenthal argued that a verb stem such as /ramaj+ta/, ‘you threw’ and /rami+ta/, which are both derived from the root  $\sqrt{\text{rmj}}$ , are both consonant-final. In /ramaj+ta/, the glide /j/ occupies the consonant position and in /rami+ta/, the final segment is also a glide but it happens to be vocalized. Both representations of the glide and the vocalized glide occupy a mora position. Thus, both satisfy the constraint FINAL-C (ONSONANT). Other constraints which might force the glide to surface with its consonantal features in final position are: where the constraint maintains the minimal number of two root consonants in an underived word, and if the constraint requires the minimal bimoraicity prosodic structure of the word.

Turning to the preserved diphthongs in /ʒaw/ and /zaj/. For the sake of simplicity, only the diphthong preservations in the final positions are considered in the light of two interactive constraints. The first is NO-DIPH which militates against diphthongs and the second is FINAL-C which requires a stem to have a consonantal coda in the final position. The FINAL-C constraint is defined as follows:

FINAL-C: A stem is consonant-final, (McCarthy and Prince, 1990a, 1990b).

(182)

Input: [ʒaw]	FINAL-C	NO-DIPH
a. → /ʒaw/		*
b. /ʒa:/	*!	
c. /ʒu:/	*!	
d. /ʒo:/	*!	

All three candidates (b), (c) and (d) exhibit the lengthening of their vowels and are possible vocalized forms of the glide /w/. However, these vocalized forms violate the higher ranked constraint FINAL-C. Although it violates NO-DIPH, candidate (a) satisfies the higher ranked constraint since the glide surfaces with its consonantal feature. Similarly, for the stem /zaj/, the glide surfaces with its consonantal feature, satisfying FINAL-C.

So far, only the surface features of the glide have been analyzed. At the same time, it has been assumed that, in order for the glide to surface as a homorganic long vowel, its vocalic element must be parsed moraicly. Otherwise, the glide surfaces as an onset since its consonantal features overcome its vocalic features. The surfacing of a glide as an onset is productive in the derivation of the BP form from its base (its singular form) which has a glide at the underlying level. In the base form, the glide surfaces as moraic, which yields a homorganic long vowel. However, in its BP correspondent form, the glide surfaces as an onset in the position of the second root consonant. The identification of  $C_2$  is vital in BP formation since it hosts the BP affix. Thus, the surface form of the glide is subject to two conflicting constraints;  $\{I, U\} = \mu$  which forces the glide to surface as a mora, and  $GLIDE=ONSET$  which forces the glide to surface as a consonant. The two constraints are defined below:

$\{I, U\} = \mu$  : Vocalic elements of  $\{I\}$  and  $\{U\}$  are moraic, (Rosenthal, 1997).

$GLIDE=ONSET$ : A glide must surface as a consonant.

Consider the follow example:

(183)  $/b_1a : b_3/$ , ‘door’  $\Rightarrow$   $/b_1w_2a : b_3/$ , ‘doors’

The homorganic long vowel of the base  $/b_1a : b_3/$  is at the underlying level represented as a short vowel plus a glide sequence  $/b_1aw_2b_3/$ . Due to restrictions on such sequences to surface in the pattern  $/C_1vC_2C_3/$  where  $C_2$  is a glide, the glide surfaces with its vocalic feature yielding  $/b_1a : b_3/$ . As introduced in chapter two, the derivation of a BP form from its correspondent singular form involves a correspondent relation between two independent outputs. Each output has an underlying correspondent input. Thus, the base  $/b_1a : b_3/$  is in a correspondence relation with its underlying form,  $/b_1aw_2b_3/$ , and the output  $/b_1w_2a : b_3/$  is in a correspondence relation with its underlying form,  $/b_1a : b_3/$  plus the BP affix  $/a : /$ . Now, the glide, which surfaces as a homorganic long vowel in the base, surfaces with its consonantal feature as an onset in the BP form  $/b_1w_2a : b_3/$ . That is to say, the active constraint  $\{I, U\} = \mu$  which forces the glide to surface as a mora in the input-

output relation of the base and its underlying form, is dominated by GLIDE=ONSET which requires the glide to surface as onset. The surface of a glide with its consonantal feature in BP formation is supported by two facts: the first is to identify the position of C<sub>2</sub> to host the BP affix, and the second is to satisfy the minimality requirements of three root consonants in the derivational morphological process.

The tableau below accounts for the consonantal feature of the glide. Candidate (b) loses because it does not identify this consonantal feature. The winning candidate (a) successfully identifies this feature and consequently succeeds in identifying the position of C<sub>2</sub>.

(184)

Base: [b <sub>1</sub> a : b <sub>3</sub> ] + â :	GLIDE=ONSET	{I, U} = μ
Output: [b <sub>1</sub> w <sub>2</sub> a : b <sub>3</sub> ]		
a. /b <sub>1</sub> w <sub>2</sub> a : b <sub>3</sub> /		*
b. /b <sub>1</sub> a : a : b <sub>3</sub> /	*!	

The appearance of the glide /w/ in the BP form is constrained by the underlying glide of the base singular. A similar account can be given of the base /ʔi : d/, ‘festival’, which underlyingly is /ʔi j d/. In the derivation of its BP form, the glide surfaces to fill the onset of C<sub>2</sub> of the output BP form. Consider the follow tableau:

(185)

Base: [ʔ <sub>1</sub> i : d <sub>3</sub> ] + â :	GLIDE=ONSET	{I, U} = μ
Output: [ʔ <sub>1</sub> j <sub>2</sub> a : d <sub>3</sub> ]		
a. → /ʔ <sub>1</sub> j <sub>2</sub> a : d <sub>3</sub> /		*
b. /ʔ <sub>1</sub> i : a : d <sub>3</sub> /	*!	

In LA, an underlying vowel plus glide usually surfaces as a long vowel. However, there is another phenomenon concerning the phonological realization of morphologically governed long vowels. In the derivational morphology of active participles in LA, a long vowel /a :/ is infixes between C<sub>1</sub> and C<sub>2</sub>, as in /ka : t i b/, ‘writer’, from the root √k t b. Some of the singular nouns of the pattern /C<sub>1</sub>a : C<sub>2</sub>i C<sub>3</sub>/ qualify for the BP pattern /C<sub>1</sub>aw<sub>4</sub>a : C<sub>2</sub>i C<sub>3</sub>/, in which the long vowel of the base

singular is realized as a glide /w/ in the BP form. The position of this glide occupies the position of C<sub>2</sub> and it attracts the BP morpheme when the BP form is formed. But it seems that the appearance of such long vowels as glides in the derivation of BP is more complicated than this. However, let us take the following singular examples which exhibit morphological long vowel morphemes and consider their actual realization in the BP form:

(186) Singular form	BP form
/x <sub>1</sub> a:t <sub>2</sub> am <sub>3</sub> /, ‘signet-ring’	/x <sub>1</sub> aw <sub>4</sub> a:t <sub>2</sub> im <sub>3</sub> /
/ʒ <sub>1</sub> a:m <sub>2</sub> u:s <sub>3</sub> /, ‘buffalo’	/ʒ <sub>1</sub> aw <sub>4</sub> a:m <sub>2</sub> i:s <sub>3</sub> /
/ʒ <sub>1</sub> az <sub>2</sub> i:r <sub>3</sub> -at/, ‘island’	/ʒ <sub>1</sub> az <sub>2</sub> a:j <sub>4</sub> ir <sub>3</sub> /
/r <sub>1</sub> is <sub>2</sub> a:l <sub>3</sub> -at/, ‘letter’	/r <sub>1</sub> as <sub>2</sub> a:j <sub>4</sub> il <sub>3</sub> /
/ħ <sub>1</sub> al <sub>2</sub> u:b <sub>3</sub> -at/, ‘milch-camel’	/ħ <sub>1</sub> al <sub>2</sub> a:j <sub>4</sub> ib <sub>3</sub> /
/g <sub>1</sub> in <sub>2</sub> d <sub>3</sub> i:l <sub>4</sub> /, ‘lantern’	/g <sub>1</sub> an <sub>2</sub> a:d <sub>3</sub> i:l <sub>4</sub> /
/s <sub>1</sub> ul <sub>2</sub> t <sup>ʕ</sup> <sub>3</sub> a:n <sub>4</sub> /, ‘Sultan’	/s <sub>1</sub> al <sub>2</sub> a:t <sup>ʕ</sup> <sub>3</sub> i:n <sub>4</sub> /

The subscript numbers show the correspondence relation and do not intend to show the order of roots. In the singular forms, the long vowels occupy different positions. The long vowels in /x<sub>1</sub>a:t<sub>2</sub>am<sub>3</sub>/ and /ʒ<sub>1</sub>a:m<sub>2</sub>u:s<sub>3</sub>/ are in the first syllable, while in /ʒ<sub>1</sub>az<sub>2</sub>i:r<sub>3</sub>-at/, /r<sub>1</sub>is<sub>2</sub>a:l<sub>3</sub>-at/, and /ħ<sub>1</sub>al<sub>2</sub>u:b<sub>3</sub>-at/ they are in the second syllable, and in /g<sub>1</sub>in<sub>2</sub>d<sub>3</sub>i:l<sub>4</sub>/ and /s<sub>1</sub>ul<sub>2</sub>t<sup>ʕ</sup><sub>3</sub>a:n<sub>4</sub>/ in the third syllable. Looking at the BP forms, only the long vowels of /x<sub>1</sub>aw<sub>4</sub>a:t<sub>2</sub>im<sub>3</sub>/ and /ʒ<sub>1</sub>aw<sub>4</sub>a:m<sub>2</sub>i:s<sub>3</sub>/ surface as the glide /w/ which appears in the position of C<sub>2</sub>. This glide surfaces as an onset of the newly created syllable which takes the BP morpheme /a:/ as its nucleus. In the examples /ʒ<sub>1</sub>az<sub>2</sub>a:j<sub>4</sub>ir<sub>3</sub>/, /r<sub>1</sub>as<sub>2</sub>a:j<sub>4</sub>il<sub>3</sub>/, /ħ<sub>1</sub>al<sub>2</sub>a:j<sub>4</sub>ib<sub>3</sub>/, /g<sub>1</sub>an<sub>2</sub>a:d<sub>3</sub>i:l<sub>4</sub>/ and /s<sub>1</sub>al<sub>2</sub>a:t<sup>ʕ</sup><sub>3</sub>i:n<sub>4</sub>/, the BP morpheme is infixes after the second root consonant creating a new syllable, whereas in /x<sub>1</sub>aw<sub>4</sub>a:t<sub>2</sub>im<sub>3</sub>/ and /ʒ<sub>1</sub>aw<sub>4</sub>a:m<sub>2</sub>i:s<sub>3</sub>/ the BP morpheme is not attached to the second root consonant but rather to the glide. The change of the long vowel to the glide /w/ suggests that the glide formation takes place before plural formation. This notion is supported by the normal BP formation of such patterns which attracts the plural formation process after the second root consonant.

However, there are three possibilities for the surface expression of the long vowel: it surfaces as a glide, or is deleted due to the unavailability of a hosting active morphological site, or is preserved as a long vowel. Glide formation, which, as discussed above, is very common when a word/stem exhibits a long vowel in the first syllable, undergoes BP formation. It is quite clear that the BP morpheme /a:/ overwrites the long vowels of the singular forms. It seems that the active morphological site of the BP is filled by the BP morpheme /a:/ which consequently deprives the long vowels of the singular forms from appearing. The appearance or disappearance of long vowels in BP derivation is constrained by the availability of an unoccupied derivational site. This morphological site cannot be occupied by more than one morpheme at a time. The preservation of long vowels in the BP forms in /g<sub>1</sub>an<sub>2</sub>a:d<sub>3</sub>i:l<sub>4</sub>/ and /s<sub>1</sub>al<sub>2</sub>a:t<sup>ʔ</sup><sub>3</sub>i:n<sub>4</sub>/ is due to the availability of a free derivational morphological site, whereas the change of the quality of the BP form in /s<sub>1</sub>al<sub>2</sub>a:t<sup>ʔ</sup><sub>3</sub>i:n<sub>4</sub>/ is evidence that the phonology requires it to surface as a front long vowel /i:/, as is the case with /g<sub>1</sub>an<sub>2</sub>a:d<sub>3</sub>i:l<sub>4</sub>/.

The glide /j/ in the BP forms of /ʒ<sub>1</sub>az<sub>2</sub>a:j<sub>4</sub>ir<sub>3</sub>/, /r<sub>1</sub>as<sub>2</sub>a:j<sub>4</sub>il<sub>3</sub>/, and /h<sub>1</sub>al<sub>2</sub>a:j<sub>4</sub>ib<sub>3</sub>/ is not the realization of the long vowels of the singular forms, but is rather actually the realization of the glottal stop /ʔ/. In LA, the glottal stop regularly surfaces as a glide /j/ word medially (Abumdas, 1985, 154). But what triggers this glottal stop to surface? Let us take one instance to illustrate the triggering of the glide /j/:

(187)        /ʒ<sub>1</sub>az<sub>2</sub>i:r<sub>3</sub>-at/, 'island'                      /ʒ<sub>1</sub>az<sub>2</sub>a:j<sub>4</sub>ir<sub>3</sub>/

In BP formation, a suffix is always deleted and short vowels are not carried over to the plural form. What is transferred from the singular is the root consonants, and the long vowel yields /ʒ<sub>1</sub>z<sub>2</sub>i:r<sub>3</sub>/.

Now, in order to form the BP, the BP morpheme must be infixes after the second root consonant. This creates a problem since the long vowel of the singular occupies this position. Since a morphological site cannot be filled by more than one morpheme at a time, the BP morpheme overwrites the long vowel to yield /ʒ<sub>1</sub>az<sub>2</sub>a:r<sub>3</sub>/.

Since the BP pattern is trisyllabic and since the syllable



that hosts the BP morpheme is always an independent open heavy syllable, the last root consonant forms a new syllable where an epenthetic glottal stop is inserted to fill its onset and an epenthetic vowel to fill the nucleus yield /ʒ<sub>1</sub>aʒ<sub>2</sub>a : ʔ<sub>4</sub>i r<sub>3</sub>/. Then, the glottal stop is changed to a glide based on LA preference.

#### 4.4.3 Vowel and Consonant Lengthening

Lengthening is a process in which LA tends to prolong vowels as well as consonants. LA exhibits the prolonging of vowels in both nouns and particles. In particles, the last short element is lengthened before the suffix /C#/. For example, the consonant is lengthened in /min+ k/, ‘from you’ ⇒ /minnək/, /ʔan+ i/, ‘about me’ ⇒ /ʔanni/; in vowel lengthening, the particle /li/, ‘for’ + any pronoun triggers lengthening of the vowel as in /li+ hum/, ‘for them’ ⇒ /li:hum/, /li+ k/, ‘for you (fem.)’ ⇒ /li:k/. Vowel lengthening in nominal forms is frequent in trilateral words where the first consonant root is a glide /w/. The CA realization of initial glide /w/ in *Masdar* (nominalised form) is represented in the following examples:

(188)	Root consonants	Perfective	( <i>Masdar</i> )
	/wʒh/	/waʒʒah/	/ʒihah/, ‘direction’
	/wθq/	/waθiq/	/θiqah/, ‘rely/trust’
	/wzn/	/wazan/	/zinah/, ‘weigh’
	/ws <sup>ʔ</sup> f/	/was <sup>ʔ</sup> af/	/s <sup>ʔ</sup> ifah/, ‘description’
	/ws <sup>ʔ</sup> l/	/was <sup>ʔ</sup> al/	/s <sup>ʔ</sup> ilah/, ‘relativeness/relation’

LA realization of initial glide /w/ in *Masdar* is as follows:

(189)	/ʒi:hah/
	/θi:qah/
	/zi:nah/
	/s <sup>ʔ</sup> i:fah/

/s<sup>ɨ</sup>i:lɑh/

Both the CA and LA examples exhibit the loss of the glide initially in nominalised forms. The stress falls on the first syllable of the nominalised forms. The only difference, however, is that in LA the vowel of the stressed syllable is lengthened and becomes bimoraic. For CA, the pattern has the structural form /CvCvh/ where the first vowel has a high feature. Similarly, LA has preserved the high feature of the vowel, but for the purpose of stress assignment the initial vowel is lengthened. Some nouns of the form /CvCCvC/ also exhibit vowel lengthening. The second vowel of this pattern is lengthened, as in:

(190)	CA	LA	(Abumdas, 1985, 247)
	/qunfuð/	/gunfu:d/, ‘hedgehog’	
	/mat <sup>ɨ</sup> raħ/	/mat <sup>ɨ</sup> ra:h/, ‘place’	
	/sullam/	/sallu:m/, ‘ladder’	
	/muʃmuʃ/	/miʃma:ʃ/, ‘apricot’	

In LA, final consonantal root glides in verbs form diphthongs, which may surface as short vowels as in /bana.j/, ‘he built’, which surfaces as /bane:/. However, when object suffixes are attached to such verbs, they retain the weight of that diphthong which surfaces as a long vowel. Thus, the lengthening of the vowel is the result of the satisfaction of the bimoraicity structure of the language. The following examples represent the lengthening of vowels in LA:

(191)	Underlying Form	Surface Form	Stem plus Object Suffixes
	/sammaw/	/samma+ h/	/samma:h/, ‘he named him’
	/ʔat <sup>ɨ</sup> aj/	/ʔat <sup>ɨ</sup> a+hum/	/ʔat <sup>ɨ</sup> a:hum/, ‘he gave them’ masc.
	/ʒaʔaʔ/	/ʒe+ kin/	/ʒa:kin/, ‘he came to you’ fem. + Pl.

The claim for the bimoraicity requirement comes from the fact that even when, for example, the subject feminine pronoun /-t/ is inserted between the stem verb and the object suffix, bimoraicity has to be respected. If the subject suffix is of the form

/-(C) v/, then this suffix is adjoined to a syllable to occupy the coda position forming a bimoraic syllable of the type /CvC/. It must be recalled that /t/ in this position is not considered as extrametrical since it is not positioned at the periphery. Examples are as follows:

- (192) /sammathum/, ‘she named them’  
 /ʕɑt ʕɑtkum/, ‘she gave you’ masc + Pl.  
 /ʒathin/, ‘she came to them’ fem.

On the other hand, however, if the subject suffix is of the form /- vC/, which is the feminine /-it/, and if the object suffix is of the form /-Cv(C)/, then two processes take place. One is the preservation of the vowel /i/, and the second is the lengthening of the vowel that precedes the subject suffix (Harrama, 1993, 39-40), as in:

- (193) /sa:ʕid+ it+ ah/ ⇒ /sa:ʕada:tah/, ‘she helped him’  
 /sa:ʕid+ it+ ak/ ⇒ /sa:ʕada:tak/, ‘she helped you’ masc. + sing.  
 /sa:ʕid+ it+ ik/ ⇒ /sa:ʕada:tik/, ‘she helped you’ fem. + sing.

Thus, the difference between the last two examples is represented by the quality of the vowel of the last syllable in each word. The preservation of the vowel /i/ is to mark the feminine gender. Furthermore, subject suffixes tend to be hosted in heavy syllables when they occur between the stem verb and the object suffix as in:

- (193) /sa:nid+u+kum/ ⇒ /sa:ndu:kum/, ‘they supported you masc. + Pl.  
 /sa:ʕid+ na+kin/ ⇒ /sa:ʕidna:kin/, ‘we helped you’ fem. +Pl.  
 /kallam+ ti+ ah/ ⇒ /kallimti:h/ ‘you (fem. + sing.) talked to him’

It seems that vowel lengthening in the above examples is the result of stress assignment, because stress in LA falls on the heavy syllable.

Some adjectives of the form /CvCvC/ are realized as /CvvCvC/ in LA. In the comparison that follows between CA and LA, it can be seen that the corresponding vowel of the first syllable is lengthened in LA:

(194)	CA	LA
	/s <sup>ɪ</sup> aʃab/	/s <sup>ɪ</sup> ɑ:ʃib/, ‘difficult’
	/xarib/	/xɑ:rib/, ‘destroyed/rotten’
	/sahal/	/sa:hil/, ‘easy’

The lengthening of the initial vowel in LA could be attributed to one of the following factors: either to the stress, since the stress falls in the initial syllable; or to the morphological derivational process of these adjectives. It might be more plausible to assume that these adjectives in CA correspond to or are realized as active participle adjectives in LA which is morphologically assigned by the long vowel morpheme /a:/.

#### 4.4.4 Geminates

Gemination here refers to the phonological or morphological process where a consonant is doubled, creating a sequence of two identical consonants.

##### 4.4.4.1 Initial Consonant Doubling

The definite article /l-/ assimilates with any following coronal sound. This is assimilation across the morpheme boundary which leads the definite article to lose its features and acquire those features of the following coronal sound. Thus, the result of this assimilation process is the doubling of the initial coronal consonant of the stem word, as in:

(195)	/l+ʃaba:b/	⇒	/ʃʃaba:b/, ‘the youths’ masc. + PL.
	/l+s <sup>ɪ</sup> u:ra/	⇒	/s <sup>ɪ</sup> s <sup>ɪ</sup> u:ra/, ‘the picture’ fem. + sing.
	/l+na:r/	⇒	/nna:r/, ‘the fire’

However, this is not the case for non-coronal sounds, as represented in the following examples:

- (196)     /ɫ+ʕiʝu:n/         ⇒         /ɫʕiʝu:n/, ‘the eyes/oases’  
            /ɫ+ga:ʝla/         ⇒         /ɫga:ʝla/, ‘the afternoon’ fem.  
            /ɫ+ward/           ⇒         /ɫward/, ‘the rose’

#### 4.4.4.2 Medial Consonant Doubling

Consonant doubling in the medial position occurs within the morpheme and across morpheme boundaries. Within the morpheme boundary, the grammatical derivation of some lexical classes involves doubling of the second root consonant in trilateral words. In verbs, Form II trilateral verbs of the form /CvCCvC/ are formed by doubling the second consonant of Form I trilateral verbs /CvCv(C)/:

- (197)     Form II trilateral verb  
            /ʕɑɫɫɑt ʕ/, ‘he made sb. make a mistake’  
            /kaɫɫab/, ‘he made sb. write’  
            /maʕʕa:/, ‘he directed/caused sb. walk’

However, in many cases Form II verbs do not have Form I correspondence verbs, but rather they are derived by doubling the second root consonant:

- (198)     /kaɫɫam/, ‘he talked to sb.’  
            /ʕaɾraɾab/, ‘he tried sth.’  
            /ħawwal/, ‘he moved sth.’

Also’ in nouns, the VN /CvCCvvC/ is derived from Form I or II trilateral verbs by doubling the second root consonant as well as lengthening the vowel of the last syllable. This verbal noun carries a semantic reference, since it denotes a profession, the name of a tool, or a repeated action, as in:

(199) Trilateral Form I verb	Derived Verbal Noun
/rasam/ ‘he drew’	/rissa:m/, ‘artist’
/ʕamal/ ‘he did sth.’	/ʕummɑ:l/, ‘workers’ masc. + Pl.
/ʕazan/ ‘he made a cement/bread’	/ʕiʕʕa:na/, ‘bread/cement mixer’ fem.
Trilateral Form II verb	Derived Verbal Noun
/xallat <sup>ʕ</sup> / ‘he mixed’	/xalla:t <sup>ʕ</sup> /, ‘mixer’
/ħallaq/ ‘he had his hair cut’	/ħilla:q/, ‘barber’

In all the examples above, each of the doubled consonants is hosted in a different syllable. That is to say that the first consonant occupies the coda of the first syllable, whereas the second consonant occupies the onset of the second syllable.

The lexical and non-lexical words in the two groups below are formed by a biconsonantal root plus a possessive pronoun suffix. By contrast, the two groups behave differently: in group (a) the suffix is headed by a vowel, whereas in group (b) it is headed by a consonant. As can be seen from the first group, since the requirements of good formation for the syllable in LA necessitate it to having an onset at the surface, and also since the suffix is headed by a vowel, this forces the suffix to form a syllable of its own by geminating the coda of the preceding syllable in order to form its own onset. However, in the second group, because the suffix is already headed by an onset consonant, the suffix forms its own syllable without geminating the preceding consonant:

(200)			
a.	/jad+i/	⇒	/jaddi/, ‘my hand’
	/fam+ak/	⇒	/fammak/, ‘your (sing. + masc.) mouth’
	/ʕan+ah/	⇒	/ʕannah/, ‘about him’
	/ʕum+i/	⇒	/ʕummi/, ‘my mother’
b.	/jad+ha/	⇒	/jadha/, ‘her hand’
	/fam+ha/	⇒	/famha/, ‘her mouth’

/ʕan+hum/           ⇒           /ʕanhum/, ‘about them’  
 /ʔum+hin/           ⇒           /ʔumhin/, ‘their (fem.) mother’  
 /kaħħ/               ⇒           /kaħħa/, ‘a cough’

#### 4.5 The Prosodic Word in LA

Based on the prosodic hierarchy in which the word dominates the foot, the minimal word in Arabic has only one metrical foot. The minimal base (stem or word) must be a single quantitative trochee /CvCv/ (light syllable) or, equally, two moras /Cvv/ or /CvC/ (heavy syllable). Although the stem or the word in Arabic requires a final unparsed consonant in /CvCC/ or final /CvC/, this has no role in the weight of the syllable. The unparsed final segment is considered to be an incomplete syllable or extrasyllabic. Because final incomplete syllables are considered as extrametrical, they are not affected by the minimal word requirements; however, they may be required in order to satisfy the well-formation of Arabic stems (; McCarthy and Prince, 1990a, 1990b; Watson, 2002). LA exhibits three types of syllables: /Cv/, which is considered as light; and /Cvv/ and /CvC/ which are considered heavy. They are represented as follows:

(201)

a. Light syllable Cv

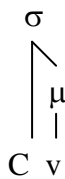

b. Heavy syllables Cvv and CvC

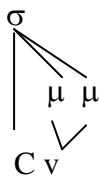

/ˈkaː.tib/, ‘writer’

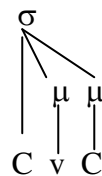

/ˈħuk.muk/, ‘your judgement’

The moraic trochee plays an important role in the Arabic system of prosody (McCarthy and Prince, 1990a, 1990b). The quantitative trochaic foot as the minimal word in LA is represented as follows:

(202)

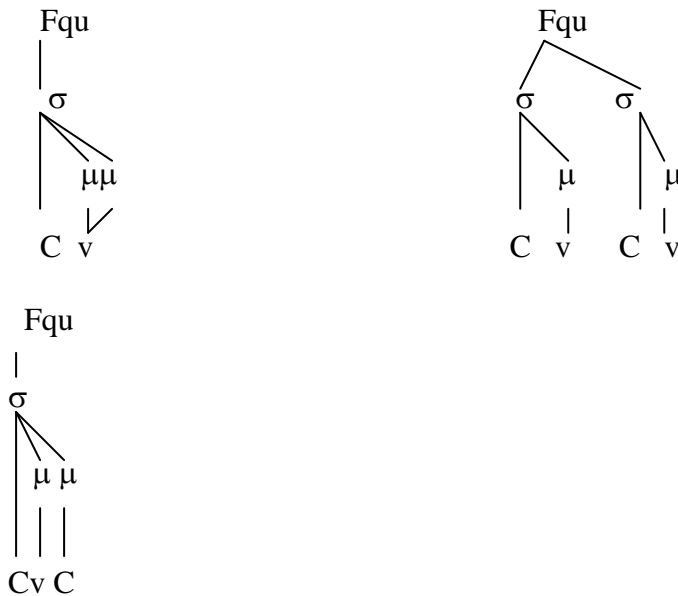

In the above tree diagrams, the trochaic quantitative foot is represented in three possible forms. In Cv and CvC, both feet consist of one syllable each, and each syllable consists of two moras, and thus they carry the same weight. The only difference between these two feet is that in Cv both moras are occupied by two vowels which form a long vowel. On the other hand, the moras in CvC are represented by a vowel and a consonant. In CvCv the two moras are divided between the two syllables where each carries one mora in weight. All the trochaic quantitative feet are bimoraic. Thus, the minimal word in Arabic can be either a single bimoraic syllable or two consecutive monomoraic syllables.

(203)

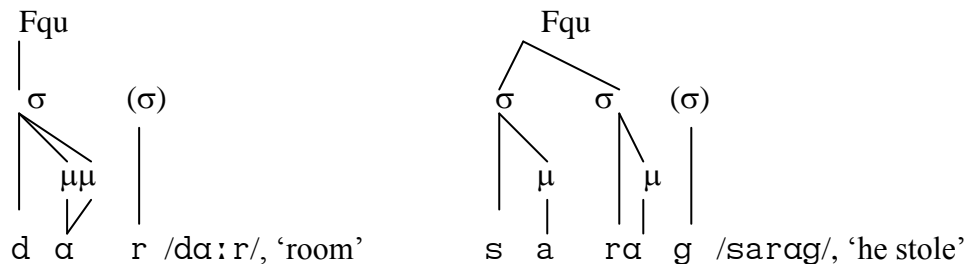



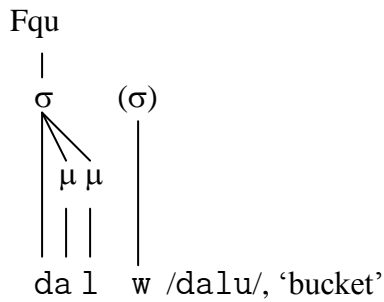

The parenthesized syllables are incomplete, and they are considered extrametrical since they do not contribute to the weight of the feet represented by the words above. All these words satisfy the minimal requirements of bimoraicity (McCarthy and Prince, 1990a).

It must be noted that there are words in Arabic that do not fulfil the minimal word requirements. McCarthy and Prince listed some examples, such as:

- Nonlexical words as in /wa/, 'and', /bi/, 'in/with'. These words are not bimoraic, and thus they fail the minimal word requirement.
- A few lexical biliteral words such as /ʔab/, /bin/, 'son'. These biliteral words have one mora, and this class is very limited. Interestingly, McCarthy and Prince (1990a:50) observed that this class of biliteral words mostly represents either near kin (/ʔab/, 'father' or /ʔax/, 'brother') or parts of the body as in (/dam/ 'blood' or /fcm/ 'mouth'). When these biliteral nouns are joined to possessive suffixes for example, the resulting forms would be at least two moras long: for example, /ʔax+j/ ⇒ /ʔaxj/, 'my brother', /dam+j/ ⇒ /damj/, 'my blood'. In LA, the resulting forms are either a prolongation of the vowel of the stem noun or the gemination of the last consonant of the stem noun. Thus, the examples are represented as /ʔax+j/ with long vowel insertion ⇒ /xu : j/, and /dam+j/ through gemination ⇒ /dammi j/
- Some imperative words such as /daʕ/, 'leave' from the root /wdʕ/, and /ktub/, 'write' from the root /ktb/.

These lists of exceptions are exhaustive. In cases where these apparent monomoraic words interact in the morphology of the language, they display the satisfaction of the minimal word requirement. For example, in CA, /ʔab/ satisfies word minimality when the dual is derived; this gives /ʔabaw+a:n/, ‘two fathers’. The imperative form has two characteristics, both of which involve the morphological truncation or deletion of the last vowel of the indicative imperative and the loss of the agreement marker. These two processes do not create an environment for satisfying word minimality (McCarthy and Prince, 1990a, 19).

In supporting their claim of the minimal word in Arabic, McCarthy and Prince (1990a, 19-23) presented four pieces of evidence where word minimality is respected;

- There are a considerable number of monosyllabic words where the last two consonants are identical, as in /tall/, ‘hill’. In this case, the biliteral root /tɫ/ satisfies the minimal moraic condition through geminating the final consonant.
- In *Masdar*, the initial root /w/ loss is compensated for by the feminine suffix /+at/ which identifies the only *Masdar* type that requires feminine marker suffixation. For example, /waθiq/, ‘to trust (perfective)’ ⇒ /θiqat/, ‘trust (*Masdar*)’.
- Many monomoraic borrowed words are treated as bimoraic in Arabic, such as the English word /gas/, ‘gas’ ⇒ /ga:z/.
- Truncated vocative. In CA, the truncated vocative respects word minimality if it is not already bimoraic, as in: /ma:lik/ ⇒ /ma:li/ (proper name, masculine), /suʔa:d/ ⇒ /suʔa:/ (proper name, feminine), /marwa:n/ ⇒ /marwa/ (proper name, masculine).

Furthermore, in their study of BP, McCarthy and Prince (1990a, 252) suggested that the initial bimoraic sequence, which is either the moraic or the trochee, is targeted and circumscribed in order to map the BP template.

In their counting of nouns that take BP in the first half of Wehr's dictionary (Wehr and Cowan, 1961), McCarthy and Prince (1990a; 1990b) accounted for the following basic underived nominal patterns found in the CA:

(204) Basic Nominal Patterns found in CA

Root consonants	Mora Count				
	Two		Three		Four
Biliteral	/C <sub>1</sub> vC <sub>2</sub> C <sub>2</sub> / (6%)	/C <sub>1</sub> vC <sub>2</sub> vC <sub>2</sub> / (<1%)	/C <sub>1</sub> vC <sub>2</sub> vvC <sub>2</sub> / (3%)	/C <sub>1</sub> vvC <sub>2</sub> vC <sub>2</sub> / (<1%)	/C <sub>1</sub> vvC <sub>2</sub> vvC <sub>2</sub> / (<1%)
Triliteral	/C <sub>1</sub> vC <sub>2</sub> C <sub>3</sub> / (27%)	/C <sub>1</sub> vC <sub>2</sub> vC <sub>3</sub> / (7%)	/C <sub>1</sub> vC <sub>2</sub> vvC <sub>3</sub> / (18%)	/C <sub>1</sub> vvC <sub>2</sub> vC <sub>3</sub> / (12%)	/C <sub>1</sub> vvC <sub>2</sub> vvC <sub>3</sub> / (2%)
Quadriliteral				/C <sub>1</sub> vC <sub>2</sub> C <sub>3</sub> vC <sub>4</sub> / (14%)	/C <sub>1</sub> vC <sub>2</sub> C <sub>3</sub> vvC <sub>4</sub> / (11%)

Adapted from McCarthy and Prince (1990b:24)

- Identical consonant numbers mean identical geminated consonants.

As can be seen from the table, the prosodic structure of the noun ranges from bimoraic to quadrimoraic. The table also shows that the minimal word is constrained by two facts: the first is that the minimal word is bimoraic, as in /C<sub>1</sub>vC<sub>2</sub>C<sub>2</sub>/ and it can be maximally disyllabic, as in /C<sub>1</sub>vC<sub>2</sub>C<sub>3</sub>vvC<sub>4</sub>/. The minimality and maximality represent the underived noun forms. These facts could be translated into two constraints (McCarthy and Prince, 1990a, 1990b) as follows:

Minimal Stem constraint

Templates are minimally bimoraic.

Maximal Stem Constraint

Templates are maximally disyllabic.

Any underived noun respects these two constraints. The minimal stem requirement is /CvCv/, /Cvv/ or /CvC/ which in any case maintains the minimal bimoraic requirements for the stem. On the other hand, the maximal number of syllables in underived words is two.

## 4.6 Stress Assignment in LA

In LA, each word has a single main stress. The stress can fall on the ultimate, penultimate, or antepenultimate syllable. The examples below represent the distribution of stress assignment in LA:

(205)

- Stress on the ultimate syllable:

/hi.l.'ka:n/, 'tired'

/j.s<sup>ʕ</sup>ɑf.'fɑrr/, 'empty/to whistle'

- Stress on the penultimate:

/ma.'ka:tib/, 'offices'

/kal.'lim.tak/, 'I warned you' Pl. + Masc.

- Stress on the antepenultimate:

/'kit.bit/, 'she wrote'

/'ta.mar/, 'dates'

Stress patterns reveal some facts about the LA stress system. In all the examples, the weight of the syllable plays the main role in assigning stress. Thus, LA is a quantity-sensitive language. Another fact is found in regard to the treatment of superheavy syllables. The superheavy syllables /Cv<sub>v</sub>C/ and /CvCC/ are stressed regardless of their positions as in /hi.l.'ka:n/, 'tired' and /j.s<sup>ʕ</sup>ɑf.'fɑrr/, 'empty'. Assigning stress to a superheavy syllable is straightforward since it occurs without any restrictions. If the word does not have a superheavy syllable, then the assignment of stress is achieved by tracing the heavy syllable from the rightmost edge of the word, as in /ma.'ka:tib/ and /kal.'lim.tak/. These two examples show that the heavy syllables /Cv<sub>v</sub>/ and /CvC/ are stressed. It must be noted that the two words end in a

/CvC/, but since this heavy syllable occurs in the final position, its final consonant is treated as extrasyllabic. In /ma. 'ka :.tib/ and /ka.l. 'lim.tak/, both final syllables have the heavy pattern /CvC/. The final consonant fails to attract stress due to its extrametricality. In this case the preceding heavy syllable consequently attracts stress. This shows that stress is assigned starting from the rightmost edge shifting towards the leftmost edge. This turns out to be absolutely correct; where neither the ultimate nor the penultimate attracts the stress, the penult syllable is stressed as in / 'kit.bit/ and / 'ta.mar/. The assignment of stress based on the weight of the syllable reveals that LA is a quantity-sensitive language which builds moraic trochees from right to left. Furthermore, the prosodic word in the language is right-headed.

Since syllables are identified as light and heavy based on moraic weight, and since syllables are grouped based on foot structure, these assumptions suggest that there are two constraints required by the language to capture the weight of the syllable and to make sure that syllables are grouped as feet. FOOT-BIN accounts for the bimoraicity of the syllable, and PARSE-SYL requires syllables to be parsed into feet:

FOOT-BIN: Feet are binary under moraic or syllabic analysis, (Prince, 1980; Kager, 1989; Prince and Smolensky, 1993).

Under foot binarity, a foot either has two moras, for instance heavy (H) or a sequence of light syllables as (LL), or two syllables ( $\sigma\sigma$ ) (HH). The function of FOOT-BIN is to eliminate any single light syllable (L) (Kager, 1999, 161). In other words, the internal structure of the foot is minimally and maximally binary. Thus, the foot is either disyllabic or bimoraic. However, FOOT-BIN accounts for the internal weight of the foot, but not for the binary alteration of weak and strong syllables. There is a need for an additional constraint that guarantees that syllables are parsed by feet. Any syllable that is not parsed by a foot is assumed to be metrified as a degenerate foot or an immediate daughter of PrWd (Kager, 1999, 162). This constraint is defined as follows:

PARSE-SYL: Syllables must be parsed by feet, ( Hayes, 1980; Halle and Jean-Roger, 1987; Prince and Smolensky, 1993)

In this case, FOOT-BIN must dominate PARSE-SYL in order to ensure that feet are parsed in a binary manner and also to block any degenerated syllable. The tableau below illustrates this ranking:

(206)

Candidates	FOOT-BIN	PARSE-SYL
→ a. (σσ) (σσ)		
b. (σσσσ)	*!	
c. (σσ) σ.σ		*!

In the tableau, feet are arranged in brackets. The winning candidate (a) satisfies both constraints, whereas candidates (c) and (b) have one violation each.

The relation between syllable weight and stress assignment can be interpreted by a constraint known as weight-to-stress principle (WSP). This constraint requires a heavy syllable to be the head of a foot:

WSP: Heavy syllables are stressed, (Prince, 1983; Prince and Smolensky, 1993).

Related to this constraint, there is another constraint which determines the rhythmic type of feet (whether iambic or trochaic). Since bimoraicity is fully respected in LA, this constraint will be set as trochaic and it ensures that a trochaic parse is a favoured candidate. This constraint is influenced and shaped by both FOOT-BIN and PARSE-SYL. The rhythmic foot type is defined below:

RHTYPE = T: Feet have initial prominence.

Under FOOT-BIN, a trochaic foot can have minimally one syllable with two moras and maximally two syllables with a maximum of four moras. However, it is sometimes possible to find two coexisting heavy syllables which are compatible with the requirement of bimoraicity; this coexistence of two heavy syllables violates the constraint WSP which requires the main stress to be assigned to one heavy foot. This leads to the question of to which heavy syllable the stress should be assigned. In LA, the final syllable is not stressed unless it is superheavy, and thus the general tendency in the language is to avoid a foot in the final position. It must be recalled that a final

segment is considered as extrametrical because it does not contribute to the weight of the syllable. The requirement of the non-final foot is defined below:

NONFINALITY: No foot is final in PRWD, (Prince and Smolensky, 1993).

Now, the question is how to account for stress for the rightmost non-final heavy syllable. It is clear that the direction of the stress assignment is right edge directed. We need to introduce two alignment constraints. The first aligns the right edge of the PRWD with the head foot:

ALIGN (HD-FT, RIGHT, PRWD, RIGHT) (McCarthy and Prince, 1993a)

The second alignment constraint is a constraint that demands feet to be close to the right edge of the PRWD:

ALL-FT-RIGHT: Align (FT, RIGHT, PRWD, RIGHT) (McCarthy and Prince, 1993a)

GRWD = PRWD: A grammatical word must be a prosodic word.

In LA, stress does not only show the syllabification of the word or the accented syllables, but can also sometimes distinguish verbs from nouns. The trilateral VN can be distinguished from its correspondent trilateral verb by the placement of the stress:

(207)	Form I trilateral verb	Form I trilateral VN
	/na <sup>1</sup> baħ/, ‘to bark (a dog)’	/ <sup>1</sup> nabaħ/, ‘barking’
	/s <sup>ʔ</sup> α <sup>1</sup> raf/, ‘he expended’	/ <sup>1</sup> s <sup>ʔ</sup> araf/, ‘expenses’

The stress falls on the second syllable of the verb, while in the noun the stress falls on the first syllable. Abumdas restricted the stress in the syllable pattern /CvCvC/ to the ultimate syllable which exists in all Western (Magrib) Arabic dialects, and that is one of the phonological processes which distinguish it from Eastern Arabic as well as from CA (Abumdas, 1985, 95-96). Nevertheless, it seems that lexical requirements dominate syllable weight because the stressed vowels carry different lexical properties. In the verb, the second vowel is the lexical vowel supplied by the

morphology to designate the verb state, while in the VN; the first vowel is the lexical which is again supplied by the morphology to designate the noun state. The other two unstressed vowels are supplied by the phonology to avoid consonant clusters.



## 4.7 Conclusion

This chapter has explored the main phonological phenomena related to the morphophonological processes. It raised the importance of the syllable structure in understanding the well-formation structure resulting from any derivational morphological process. It also laid out the core phonological motivations for the phonological constraints that shape the well-formed structure of any derived or non-derived word. In the later discussion of the derivation of nouns, adjectives, and BP, these constraints are manipulated and many more constraints are discussed as they arise. The significance of these constraints is in giving a morphophonological account of the interaction between non-concatenative morphological processes and the phonological constraints that adjust any derived word resulting from this morphological process. The assumed templates as well-formed structures for derived words are better explained by the interaction between the morphology and the phonology. Such well-formed templates are not a morphological property as assumed by templatic morphology. They are in fact the consequence of some phonological constraints operating on a derived morphological word. In the following three chapters on nouns, adjectives, and BP formation it is shown that the morphophonological constraints are constraints responsible for shaping the well-formation structure of derived words in LA. Identifying the inputs for the derivational morphological processes of lexical words lays the ground for the first half of the process leading to optimal outputs. In addition to this, identifying the active phonological constraints which operate on any structure resulting from the morphological processes lays the ground for the other half. Thus, the relation between the derived word and its source of derivation must be seen as the interaction between morphology and phonology. However, the morphology always precedes the phonology. In this way, the morphological processes offer the underlying structure of the derived words, while the phonological processes only operate at the surface level of these derived words. In the discussion of the non-concatenative morphology of nouns, adjectives, and BP, the morphology-phonology relationship is explored in detail.

## **Chapter 5: Non-concatenative Derived Nouns in LA**

This chapter explores the non-concatenative morphology of the derived noun in LA. One of the main goals of this chapter is to identify the actual morphological processes of derived nouns, and the state of the derivational morphemes associated with noun derivation and their placement in the active morphological sites which host these morphemes. The other important aim is to account for the morphophonological constraints that well-form the optimal output derived nouns. This chapter and the following support the chapter dedicated to BP derivation. The chapter explains the prosodic structure of the noun, followed by the process of deriving the noun by examining the functional derivational morphemes, and concludes by presenting some inflectional processes related to the input noun when the BP form is derived.

### **5.1 Introduction**

Various assumptions have been put forward when addressing the morphological structure of nouns and adjectives in LA based on previous studies on the formation of BP (see chapter two, and especially sections 3.2.3 and 3.3). Following Ratcliffe (1990), the morphology of Arabic involves two levels: level one morphology is considered as non-concatenative and affects the stem by infixational processes, while in level two the morphology is considered concatenative where it does not affect the stem and is achieved by adding prefixes or suffixes. There are active morphological sites within the stem or the word that attract any morphological operations (Guerssel and Lowenstamm, 1990; Idrissi, 1997; Kihm, 2006). These active sites distinguish concatenative from non-concatenative morphology. In concatenative morphology, the sites are external and are identified by prefixes or suffixes; in non-concatenative morphology they are internal and are identified by infixation. Because concatenative morphology does not affect the stem, it can be captured by O-O correspondence constraints with special emphasis on alignment constraints in order to align the edge of a prefix or a suffix to the edge of a stem (see section 3.2.3). Non-concatenative

morphology is more complicated. Its derivation requires the reconstruction of the prosodic structure of the derived word (Ussishkin, 2006; Kramer, 2007; Tucker, 2011). Thus, the phonology of the language will play the final role in constructing a well-formed structure for a morphologically derived word.

Whether the morphological process is of the type concatenative or non-concatenative, the morphological process takes place first, and then repaired at the surface level by the related phonological constraints. Thus, in non-concatenative morphology, the input is identified as a stem plus a derivational morpheme hosted in an external active morphological site. This combination of a stem and a derivational morpheme is a morphological process which needs to be adjusted by the phonology when the derived word surfaces. It must be mentioned here that even this stem is derived as non-concatenative morphological process. That is to say, this stem is formed by the string of root consonants plus a derivational morpheme located in one of the active internal morphological sites. Similarly, in non-concatenative morphology, the input is identified as the string of the root consonants, in some cases morphological components transferred from the source of derivation, and the derivational morpheme supplied by the relevant morphological process. To put it straightforward, the two types of morphology are underlyingly pure morphological processes without any intervention from the phonology. The phonological constraints are active only at the surface level to adjust any ill-formed structure produced by the morphological processes.

The idea of correspondence theory in comparing two corresponding linguistic structures is always at work in the present discussion of the morphological derivational processes of the nominal system of LA in this chapter and chapters six and seven. Based on the findings of the discussion of the actual and active correspondent relations between the input and the output of non-concatenative morphological derivational processes in sections 2.8 and 3.3, the input for non-concatenative derivational process is identified as a string of root consonants, plus in some cases some morphological processes associated with the input, and the derivational morphemes supplied by the intended morphological process. The subsequent investigation of the derivational morphological processes of the nominal system, identifies the correspondence relations between any two corresponding

structures, whatever the relation between the source of derivation and its corresponding nominal form, and implements the derivational morphological processes that form the output, as interpreted in section 3.3.

## **5.2 Nouns**

Most LA nouns are derived from trilateral or quadrilateral lexical roots. Nouns with two or five root consonants do exist but they are rare and unproductive. Most roots with five consonants are associated with foreign loanwords. The classification of nouns involves two types:

a- Non-derived nouns.

Non-derived refers to the morphological process in which such nouns are not derived from root consonants or other grammatical categories. These nouns may refer to names of people, animals, trees, and so on, and they have different patterns.

b- Derived nouns

Generally, these are said to be derived from verbs. However, they can also be derived from other grammatical categories such as prepositions, adjectives and nouns.

### **5.2.1 Moraic Structure of Nouns**

The nouns represented below are distinguished by the moraic weight of the syllable. The moraic weight represents both the syllable and the foot types found in the derivation of nouns.

The templates associated with the follow examples are just for illustration of the prosodic structure of the nouns. They do not have any theoretical implications, as the templates in this thesis are considered as only the product of morphophonological processes, and they do not exist as a level of representation in the morphology.

### 5.2.1.1 Triliteral Nouns with Two Moras

The moraic structure of triliteral nouns suggests that the minimal word is either /CvC(C)/ or /CvCv(C)/ with the parenthesized consonants/moras denoting extrametricality. Thus, the possible moraic structure of triliteral nouns is given below in /CvCC/ and /CvCvC/:

(208) a. /CvCC/

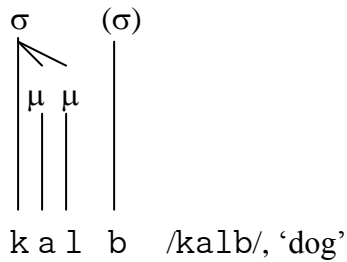

b. /CvCvC/

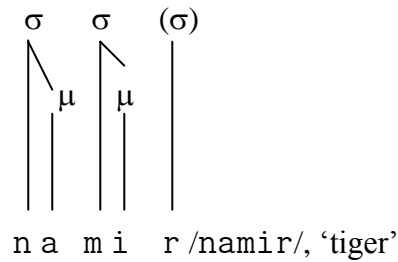

It must be noted that the noun template /Cvvc/ is at the underlying level represented as /CvGC/, where G refers to a glide. Thus, the representation of /Cvvc/ is at the underlying level represented as /CvCC/, and since /Cvvc/ is also bimoraic it will have the following representation:

c. /Cvvc/

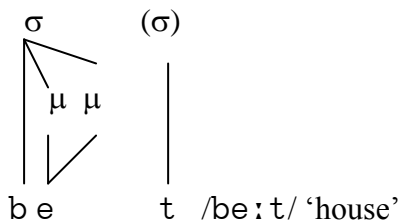

Triliteral underived nouns with two moras will have the same prosodic structure as that in /CvCC/ and /CvCvC/ respectively.

### 5.2.1.2 Triliteral Nouns with Three Moras

These nouns consist of two syllables. One of these syllables is heavy, whereas the other syllable is light:

(209) a. /Cv̄vCv̄C/

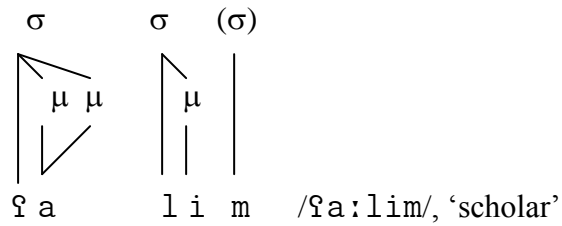

b. /Cv̄Cv̄vC/

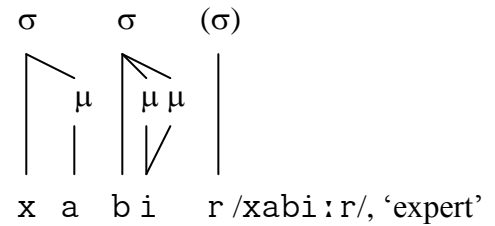

The pattern /Cv̄Cv̄vC/ is more productive than /Cv̄vCv̄C/. The most productive pattern of /Cv̄vCv̄C/ is /Ca:CiC/, and this pattern is almost always associated with the Form I active participle which is usually derived from its corresponding Form I triliteral verb /Cv̄Cv̄C/, while the /Cv̄Cv̄vC/ is more common and very diverse and is associated with more vocalic patterns. The prosodic difference between /Cv̄Cv̄vC/ and /Cv̄vCv̄C/ is that the former is headed by an iambic foot, whereas the latter is headed by a bimoraic trochaic foot plus something more (i.e. degenerated light syllable) (McCarthy and Prince, 1990a, 28). The anti-iambic form /Cv̄vCv̄C/ cannot be characterized by a single prosodic component. Thus, McCarthy and Prince (1990a) eliminated this form from the underived stem types. Furthermore, this pattern is already associated with the Form I active participle which is derived from a Form I triliteral verb. Triliteral underived nouns with three moras will have the same prosodic structure as in /Cv̄CC/ and /Cv̄Cv̄C/ above.

### 5.2.1.3 Triliteral Nouns with Four Moras

This pattern consists of two trochaic feet. It is an unproductive pattern in non-derived nouns. Triliteral underived nouns with four moras will have the same prosodic structure as that in /Cv̄vC/, for example:

(210) /Cv̄vCv̄vC/

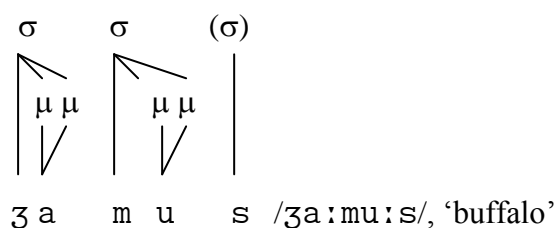

### 5.2.1.4 Quadrilateral Underived Nouns with Three Moras

In such nouns, the first syllable has two moras and the second has only one mora since the last mora is considered as extrametrical, for example:

(211) /CvCCvC/

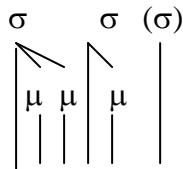

ma kti b /maktib/, 'office'

### 5.2.1.5 Quadrilateral Underived Nouns with Four Moras

From the following representation of the prosodic structure of underived noun stems, there are two very obvious observations: the first is the minimal prosodic structure of the word which is revealed to be bimoraic; and the second is that the stem nouns are shaped into templates which maximally have two syllables.

(212) /CvCCvvC/

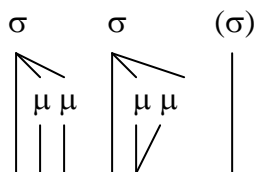

ʔ a sʔ f u r /ʔasʔfu:r/ 'bird'

## 5.3 Derivation of Nouns

The morphological derivational processes of nouns exhibit two morphological facts: the identification of the root consonants and the derivational morphemes associated with each type of noun. The derivation of nouns represented below is classified by the type of noun. In each type, the morphological and the phonological processes are explored in order to justify the well-formation structure of the optimal output.

### 5.3.1 Verbal Nouns

It is sometimes difficult to avoid the use of the unclear and misleading terminology employed by Arabic grammarians to describe a morphological derivational process. The term VN, for example, is used by grammarians to indicate that the derived noun corresponds to an input verb form. However, it is in fact not clear in what sense the derived noun is related to the verb. If this means that the verb stem is the input for the morphological derivational process, there is no doubt that the derived noun has no complete faithfulness relations to the input verb stem. What actually stand in correspondence are only the root consonants. Besides, there is no relation between the phonological components of the input and that of the output. In other words, the morphological process of the so-called VN involves the insertion of the morphological information marked by the derived noun and the restructuring of segments based on the phonological requirements of the language. On the other hand, if the idea of the noun is to describe semantically and denote the abstract nature of the derived noun, then it could be plausible to separate the process of how the action takes place which is denoted by the verb from the action referred to by the derived noun which has an abstract meaning. It is widely observed that the Arabic lexicon is based around the idea of abstract root consonants in which similar derived words are said to share some semantic meaning which is indicated by the root consonants themselves. Thus, the relation between the derived noun and the verb is held by the meaning represented by the root consonants. In this way, the correspondence relation could be understood. However, the morphological process of the derived noun brings in additional information which is inserted within the root consonants in order to derive the noun. It is difficult to claim any morphological relationship between the verb and the derived noun unless we assume that the root consonants are vital and they are present in any morphological derivational process. Consequently, it must always be kept in mind that we are not assuming any correspondence relationship between the input and the derived output other than the root consonants, and that, on some occasions, some morphological properties of the input are carried over to the derived output. Also, we will retain the idea of patterns or forms which are marked with Roman numbers and associated with Arabic morphology (Wright, 2005) for the sake of referencing since these conventions are adopted by many linguists.



Now, we could say that the VNs are derived directly from their corresponding input root consonants. They can be derived from trilateral or quadrilateral root consonants and the morphological derivational processes are divided and represented depending on the number of root consonants. Because of the productivity of derived nouns which have trilateral roots, their division is based on the type of morphological affixational process involved.

### **5.3.1.1 Trilateral Root VN**

#### **5.3.1.1.1 Form I**

This Form is derived from Form I trilateral roots. It exhibits a variety of patterns. In CA it exhibits about forty-four possible VNs for Form I trilateral VNs (Wright, 2005, Vol. I, 110-1112). LA also exhibits this unpredictability in forming the VN. For the sake of simplicity, the formation of Form I VN is classified based on the morphological derivational processes that shape this form. This classification is divided into four groups: short vowel morphemes, long vowel morphemes, long vowel plus suffixational or prefixational morphemes, and suffixational morphemes.

##### **5.3.1.1.1.1 Short Vowel Morphemes**

By short vowel morphemes we mean that the short stem vowels have a morphological function other than their phonological function. All of these verbs and their corresponding derived VNs have the surface structure pattern /CvCvC/. It must be noted that the underlying forms of the verb and the derived noun are different. In the verb form, the underlying form is /CvCvC/, where the initial unstressed vowel is often subject to deletion to create the surface form /CCvC/ (Harrama, 1993, 138). In the derived noun, the underlying structure is represented as /CvCC/, and because this form contains a coda cluster it is often the case that an epenthetic vowel is inserted to break up this cluster. The quality of such vowels is constrained by the quality of the stem vowel. The stem vowels can be either /a,i, or u/. The distribution of the vowels is as the follows, for example:

1- /C<sub>1</sub>aC<sub>2</sub>aC<sub>3</sub>/

Form I trilateral verb

/n<sub>1</sub>a<sup>1</sup> b<sub>2</sub>aḥ<sub>3</sub>/, ‘to bark (a dog)’

/w<sub>1</sub>a<sup>1</sup> z<sub>2</sub>an<sub>3</sub>/, ‘to weigh’

Form I trilateral VN

/<sup>1</sup> n<sub>1</sub>ab<sub>2</sub>aḥ<sub>3</sub>/, ‘barking’

/<sup>1</sup> w<sub>1</sub>az<sub>2</sub>an<sub>3</sub>/, ‘weight’

2- /C<sub>1</sub>iC<sub>2</sub>iC<sub>3</sub>/

Form I trilateral verb

/r<sub>1</sub><sup>1</sup> b<sub>2</sub>iḥ<sub>3</sub>/, ‘to make profit’

/ʔ<sub>1</sub><sup>1</sup> l<sub>2</sub>im<sub>3</sub>/, ‘to come to know’

Form I trilateral VN

/<sup>1</sup> r<sub>1</sub>ib<sub>2</sub>iḥ<sub>3</sub>/, ‘profit’

/<sup>1</sup> ʔ<sub>1</sub>il<sub>2</sub>im<sub>3</sub>/, ‘knowing’

3- /C<sub>1</sub>uC<sub>2</sub>uC<sub>3</sub>/

Form I trilateral verb

/ð<sup>ʔ</sup><sub>1</sub>α<sup>1</sup> l<sub>2</sub>am<sub>3</sub>/, ‘to treat unjustly’

/ʃ<sub>1</sub><sup>1</sup> r<sub>2</sub>ib<sub>3</sub>/, ‘to drink’

Form I trilateral VN

/<sup>1</sup> ð<sup>ʔ</sup><sub>1</sub>ul<sub>2</sub>um<sub>3</sub>/, ‘injustice’

/<sup>1</sup> ʃ<sub>1</sub>ur<sub>2</sub>ub<sub>3</sub>/, ‘drinking’

What is interesting in these examples is that the derived VN and its corresponding verb in the above first forms seem to be identical. However, although the stress which distinguishes the two corresponding forms is evident, there is no evidence that the stem vowels are the same since the last pair of examples shows no relation. The VN assigns stress to the initial syllable, whereas in the verb the stress is assigned to the final syllable. This raises the question of whether the /CvC/ syllable is treated as light or heavy in LA, since stress assignment in LA is based on the weight of the syllable. It is quite clear that in the verb form it is treated as heavy, while in the VN form it is treated as light. Regardless of stress assignment, the derived VNs satisfy the minimality rule of the prosodic word in LA which states that the minimal word as bimoraic. In fact, the derived VNs satisfy both the minimality and the maximality of the prosodic word; they are bimoraic and disyllabic represented by the underlying or the surface structures. Although the VN and the verb both have a string of light syllables /CvCv(C)/, they differ in assigning stress. The foot type of such a string of light syllables can either be trochaic or iambic, and the only difference is the direction of the stress. The difference is revealed by the fact that the foot in the VN form is a

trochaic where the stress is left-headed, while in the verb form the foot is iambic where the stress is right-headed.

This is merely a structural comparison between the two corresponding forms. But, in fact, this has nothing to do with the actual morphological process. The stem vowel of the VN is a morpheme which is positioned after the first root consonant  $C_1$ , while in the verb form there are two stem vowels which occupy the position after  $C_1$  and  $C_2$  respectively. In fact, the functions of the vowel morphemes distinguish the VN from the verb.

There are other types of vowel morphemes which have the surface form of long vowels. However, they are long vowels which are the surface realization of an underlying vowel plus a glide. Consider the follow examples:

4- / $C_1o:C_3$ /

Form I trilateral verb

/ $^1g_1\alpha:l_3$ /, ‘to say’

/ $^1n_1a:m_3$ /, ‘to sleep’

Form I trilateral VN

/ $^1g_1o:l_3$ /, ‘saying’

/ $^1n_1o:m_3$ /, ‘sleeping’

5- / $C_1e:C_3$ /

Form I trilateral verb

/ $^1s_1\alpha:r_3$ /, ‘to walk’

/ $^1d_1\alpha:r_3$ /, ‘to do’

Form I trilateral VN

/ $^1s_1e:r_3$ /, ‘walking’

/ $^1d_1e:r_3$ /, ‘doing’

All Form I trilateral verb forms in 4 and 5 have long vowels. These are represented as a vowel plus glide at the underlying level. For  $^1g_1\alpha:l_3$  and  $^1n_1a:m_3$ , the underlying form for the long vowel / $a:$ / is / $aw$ / and for  $^1s_1\alpha:r_3$  and  $^1d_1\alpha:r_3$ , it is / $aj$ /. Recall that glides are represented as vowels at the underlying level but at the surface level they have the feature [ $\pm$  consonant]. Thus, in this case the underlying glide may surface as a long vowel by spreading its features to the preceding vowel or acquiring the features of that vowel, or it surfaces with its consonantal features. In the verb forms, the features of the vowel / $a$ / spread to both glides, yielding a long vowel

/a:/. However, this is not the case when the VN forms are derived. The derived VN forms have mid-long vowels. These mid vowels are derived by the combination of the features of the vowel and the underlying glides. The difference between each verb and its derived VN form is how the underlying vowel plus glide surface. They surface as a long vowel /a: / in the verb form as a result of the spreading of the features of the vowel, while in the VN form the features of the glide are combined with the features of the vowel (Schane, 1984; Kaye, 1989). The underlying structures of the verb and the derived noun, which exhibit medial glides, have the same underlying structure as those which do not have a medial glide. That is to say, the verb is actually represented as /CvCvC/ underlyingly, while the derived noun has the structure /CvCC/ regardless of the state of the medial root consonant. In the following form, the medial root consonant is a glide and when the VN is derived it is suffixed with the morpheme /t/ which denotes the noun of one instance, for example:

6- /C<sub>1</sub>i:C<sub>3</sub>a-t/

Form I triliteral verb	Form I triliteral VN
/ <sup>1</sup> ħ <sub>1</sub> α:r <sub>3</sub> /, ‘to be confused’	/ <sup>1</sup> ħ <sub>1</sub> i:r <sub>3</sub> a-t/, ‘confusion’
/ <sup>1</sup> ʕ <sub>1</sub> α:r <sub>3</sub> /, ‘to be jealous’	/ <sup>1</sup> ʕ <sub>1</sub> i:r <sub>3</sub> a-t/, ‘jealousy’

In forms 7 and 8 below, the final root consonant is a glide. Given the many restrictions on the surfacing of the glide, it is forced to surface with its vocalic features in both the verb and the derived noun.

7- /C<sub>1</sub>aC<sub>2</sub>i/

Form I triliteral verb	Form I triliteral VN
/m <sub>1</sub> e <sup>1</sup> ʃ <sub>2</sub> e:/, ‘to walk’	/ <sup>1</sup> m <sub>1</sub> aʃ <sub>2</sub> i/, ‘walking’
/b <sub>1</sub> e <sup>1</sup> n <sub>2</sub> e:/, ‘to build’	/ <sup>1</sup> b <sub>1</sub> an <sub>2</sub> i/, ‘building’

8- /C<sub>1</sub>aC<sub>2</sub>u:/

Form I triliteral verb	Form I triliteral VN
/s <sub>1</sub> e <sup>1</sup> h <sub>2</sub> e:/, ‘to be inattentive’	/ <sup>1</sup> s <sub>1</sub> ah <sub>2</sub> u/, ‘inattentiveness’
/s <sup>ʔ</sup> <sub>1</sub> e <sup>1</sup> f <sub>2</sub> e:/, ‘to become pure’	/ <sup>1</sup> s <sup>ʔ</sup> <sub>1</sub> af <sub>2</sub> u/, ‘purification’

Recall that the verb is at the underlying level represented as /CvCvC/ and the derived noun as /CvCC/. In the verb form, it is clear that the resulting long mid-vowel is the result of combining the vowel with the glide, while in the noun form the glide is forced to surface with its vocalic features to create a disyllabic form. In fact, the surfacing of the glide in the final position in the derived noun is not motivated by the preference of the vocalic over the consonantal features. It is rather the preference to avoid the heavy monosyllabic structure in derived words. Let us take /m<sub>1</sub>a∫<sub>2</sub>i/ as an illustrative example which has the underlying structure [m<sub>1</sub>a∫<sub>2</sub>j<sub>3</sub>].

(213)

Input: [m <sub>1</sub> a∫ <sub>2</sub> j <sub>3</sub> ]	*CVCC	DEP	IDENT-C
a. → /m <sub>1</sub> a.∫ <sub>2</sub> i/			*
b. /m <sub>1</sub> a.∫ <sub>2</sub> i j <sub>3</sub> /		*!	
c. /m <sub>1</sub> a∫ <sub>2</sub> j <sub>3</sub> /	*!		

Because of the markedness restriction on the surface of the monosyllabic heavy syllable, candidate (c) is disregarded. Candidate (b) is a disyllabic structure but it reaches this form by using an epenthetic vowel which is not preferable for this derived noun. The winning candidate (a) shows that the preference is to force the glide to lose its consonantal features in such a way that the vocalic features surface in the nucleus position to create a new syllable. In this case, the underlying monosyllabic syllable surfaces as a string of two light syllables.

### 5.3.1.1.1.2 Long Vowel Morphemes

These infixational morphemes identify the internal active morphological sites by infixing the VN morphological morphemes between C<sub>2</sub> and C<sub>3</sub>. These morphemes have the surface form of long vowels. As can be seen from the derived VN forms below, the VN and its corresponding verb do not stand in complete correspondence. The infixed morpheme in the VN form, which surfaces as a long vowel, creates a new syllable in which it occupies the nucleus and attracts C<sub>2</sub> to the onset position and C<sub>3</sub> to the coda position. C<sub>1</sub> is either syllabified as a light syllable by an epenthetic short vowel or resyllabified by inserting a glottal stop initially to avoid onset cluster. Thus, VN derivation is achieved by syllabifying the string of root consonants plus the

infixed morpheme based on the well-formation prosodic structure of LA. Consider the following examples:

1- /C<sub>1</sub>C<sub>2</sub>u:C<sub>3</sub>/

Form I trilateral verb	Form I trilateral VN
/w <sub>1</sub> α ' s <sup>ɛ</sup> <sub>2</sub> α l <sub>3</sub> /, 'to arrive'	/o: ' s <sup>ɛ</sup> <sub>2</sub> u: l <sub>3</sub> /, 'arriving'
/h <sub>1</sub> a ' r <sub>2</sub> α b <sub>3</sub> /, 'to run away'	/h <sub>1</sub> ' r <sub>2</sub> u: b <sub>3</sub> /, 'escape'

2- /C<sub>1</sub>C<sub>2</sub>a:C<sub>3</sub>/

Form I trilateral verb	Form I trilateral VN
/' x <sub>1</sub> α : b <sub>3</sub> /, 'to become stupid'	/' x <sub>1</sub> j <sub>2</sub> a : b <sub>3</sub> /, 'stupidity'
/r <sub>1</sub> α ' g <sub>2</sub> α d <sub>3</sub> /, 'to sleep'	/r <sub>1</sub> ' g <sub>2</sub> α : d <sub>3</sub> /, 'sleeping'

3- /C<sub>1</sub>aC<sub>2</sub>a:C<sub>3</sub>/

Form I trilateral verb	Form I trilateral VN
/' θ <sup>ɛ</sup> <sub>1</sub> α l <sub>2</sub> l <sub>3</sub> /, 'to mislead'	/θ <sup>ɛ</sup> <sub>1</sub> α ' l <sub>2</sub> α : l <sub>3</sub> /, 'misleading'
/ʃ <sub>1</sub> α ' r <sub>2</sub> α b <sub>3</sub> / or /ʃ <sub>1</sub> ' r <sub>2</sub> i b <sub>3</sub> /, 'to drink'	/ʃ <sub>1</sub> α ' r <sub>2</sub> α : b <sub>3</sub> /, 'drinking'

Let us consider two representative examples, /o: ' s<sup>ɛ</sup><sub>2</sub>u: l<sub>3</sub>/ and /' x<sub>1</sub>j<sub>2</sub>a : b<sub>3</sub>/ . The follow tableau show markedness constraints play the main role in shaping the optimal candidates. In the word /o: ' s<sup>ɛ</sup><sub>2</sub>u: l<sub>3</sub>/, candidate (c) violates two markedness and one faithfulness constraints. It lacks an onset and fails to assign stress to the rightmost syllable. Also, it does not preserve the root consonant, which is the glide /w/, in violation of MAX. Candidate (b) has a complex onset and fails to capture the vocalic features of the glide /w/ in the initial position which is required by the language. Candidate (a) wins because it satisfies all markedness constraints but violates the low ranked faithfulness constraints with the initial long vowel and the glottal stop, as represented in the following tableau.

(214)

Input: [ws <sup>ɛ</sup> û:l]	*COMPLEX	{I, U} = μ	ONSET	RIGHTMOST	MAX	DEP
a. → /ʔo:.'s <sup>ɛ</sup> u:l/					*	**
b. /ws <sup>ɛ</sup> u:l/	*!	*				
c. /'o:.'s <sup>ɛ</sup> u:l/			*!	*	*	

The derivation of the VN /'x<sub>1</sub>j<sub>2</sub>a:b<sub>3</sub>/ from the verb requires the identification of the second radical root which is at the underlying level represented as the glide /j/. The surface structure of the verb is /'x<sub>1</sub>α:b<sub>3</sub>/, in which the glide surfaces as a long vowel /a:/. In order to locate the VN morpheme, the glide has to surface with its consonantal features to take the position of the host onset. The tableau shows that candidate (c) is ruled out by the \*COMPLEX constraint. Candidate (b) has a string of four consecutive vowels. This is because the glide surfaces with its vocalic feature. Consequently the VN morpheme is positioned in an onsetless syllable. Thus, candidate (b) fails to compete due to not identifying the consonantal features of the glide. Candidate (a) wins since it only violates the low ranked faithfulness constraint which penalizes epenthesis:

(215)

Input: [xjâ:b]	*COMPLEX	GLIDE=ONSET	ONSET	DEP
a. → /ʔix.ja:b/				**
b. /xi:.'a:b/		*!	*	
c. /xja:b/	*!			

There is a case where the low long vowel morpheme /a:/ phonologically surfaces as a long mid-vowel /e:/. This is because the final root consonant is actually a glide. Regardless of the type of glide and the fact that this is one of the characteristics of the glide in the final position, if this glide is preceded by a long vowel it is always subject to deletion. The actual underlying forms for /ʃ<sub>1</sub>'r<sub>2</sub>e:/ is /ʃ<sub>1</sub>ir<sub>2</sub>a:j<sub>3</sub>/ and for /d<sub>1</sub>'ŋ<sub>2</sub>e:/ is /d<sub>1</sub>uŋ<sub>2</sub>a:w<sub>3</sub>/:

4- /C<sub>1</sub>C<sub>2</sub>e:/

Form I triliteral verb  
 /ʃ<sub>1</sub>e' r<sub>2</sub>e:/, 'to buy'  
 /d<sub>1</sub>e' ʔ<sub>2</sub>e:/, 'to pray'

Form I triliteral VN  
 /ʃ<sub>1</sub>' r<sub>2</sub>e:/, 'buying'  
 /d<sub>1</sub>' ʔ<sub>2</sub>e:/, 'praying'

However, the phonological motivation for the mid-vowel is not the presence or absence of glides, as since they are not permitted to appear in this environment. At the same time the long vowel in the final position is often subject to shortening, and this long vowel carries morphological information which could be lost if its length is shortened. This causes no problem for CA, which tends to insert a glottal stop /ʔ/ stem finally to compensate for the absence of glides as well as preserving the length of the vowel. Because LA is a language closely related to CA, the actual input borrowed from CA is one which ends with the glottal stop and one that ends in a glide. This is motivated by the surfacing of the mid-vowel. Because of the shared features of the low vowel and the glottal stop, where both have back features, and because of the tendency in LA to avoid the long vowel /a:/ and the glottal stop in the final position, as well as because there is no way to simply delete them, this homogeneous structure of back features is shifted to the centre. Consider the derivation of the optimal candidate from its underlying form [ʃ<sub>1</sub>i r<sub>2</sub>a: ʔ<sub>4</sub>]:

(216)

Input: [ʃ <sub>1</sub> i r <sub>2</sub> â : ʔ <sub>4</sub> ]	*ʔ] <sub>STEM</sub>	*-VV] <sub>STEM</sub> [BACK]	*CV	MAX	IDENT-F
a. → /ʃ <sub>1</sub> r <sub>2</sub> e:/				**	**
b. /ʃ <sub>1</sub> i.r <sub>2</sub> e:/			*!	**	**
c. /ʃ <sub>1</sub> ' r <sub>2</sub> a:/		*!		**	
d. /ʃ <sub>1</sub> i' r <sub>2</sub> a: ʔ <sub>4</sub> /	*!		*		

In the tableau, all the markedness constraints are ranked higher than the faithfulness constraints. Consequently, the possible candidates (d, c, and b) are ruled out by their violations of the top ranked constraints. The optimal candidate (a) is chosen as the winner although it does not preserve the maximum segments or the identity of the input. This is because the faithfulness constraints are outranked by the markedness constraints.



### 5.3.1.1.1.3 Long Vowels Plus Suffixational or Prefixational Morphemes

The formation of the VNs here requires two morphological processes: firstly the infixation of /a:/; and secondly the suffixation of /t/. The suffix /t/ denotes the noun of one instance. This suffix is realized as /ah/ in a pause. Since suffixation belongs to level two morphology, the infixation of /a:/ takes precedence over the suffixation of /t/. Thus, the derivation of the VNs in the following examples 1 and 2 is formed by firstly infixing /a:/ in the active morphological site between C<sub>2</sub> and C<sub>3</sub>, and secondly the suffix is positioned after C<sub>3</sub>. This derivation gives the structure /C<sub>1</sub>C<sub>2</sub>a:C<sub>3</sub>t/ in which it creates consonant clusters in the initial and final positions. To avoid these clusters in the surface structure, epenthetic vowels are inserted. Consider the follow examples:

1- /C<sub>1</sub>aC<sub>2</sub>a:C<sub>3</sub>a-t/

Form I trilateral verb

/ʔ<sub>1</sub>a<sup>1</sup> d<sub>2</sub>a l<sub>3</sub>/, ‘to be fair’

/s<sub>1</sub><sup>1</sup> l<sub>2</sub>i m<sub>3</sub>/, ‘to be safe’

Form I trilateral VN

/ʔ<sub>1</sub>a<sup>1</sup> d<sub>2</sub>a:l<sub>3</sub>-at/, ‘justice’

/s<sub>1</sub>a<sup>1</sup> l<sub>2</sub>a:m<sub>3</sub>-at/, ‘safety’

2- /C<sub>1</sub>C<sub>2</sub>a:C<sub>3</sub>a-t/

Form I trilateral verb

/k<sub>1</sub>a<sup>1</sup> t<sub>2</sub>ab<sub>3</sub>/, ‘to write’

/g<sub>1</sub>a<sup>1</sup> r<sub>2</sub>e:/, ‘to read’

/<sup>1</sup>z<sub>1</sub>ɑ:r<sub>3</sub>/, ‘to visit’

Form I trilateral VN

/k<sub>1</sub>i<sup>1</sup> t<sub>2</sub>a:b<sub>3</sub>-at/, ‘writing’

/g<sub>1</sub><sup>1</sup> r<sub>2</sub>ɑ:j<sub>3</sub>-at/, ‘reading/study’

/z<sub>1</sub>i<sup>1</sup> j<sub>2</sub>ɑ:r<sub>3</sub>-ɑt/, ‘visiting’

Let us take /z<sub>1</sub>i<sup>1</sup> j<sub>2</sub>ɑ:r<sub>3</sub>-ɑt/ as an example to illustrate the derivation of this type of VN. The underlying root consonants for its trilateral verb are √zwr. The derivation of the VN involves the infixation of /a:/ between C<sub>2</sub> and C<sub>3</sub> and the suffixation of /t/ yielding the form /zwa:r t/. This derived VN requires some phonological processing to form a well-formed structure. One of the phonological processes involved is related to the actual form when a glide surfaces with its consonantal features. In LA, there is a tendency to front the features of the glide /w/ to become /j/ in a morphological

derivational environment (Abumdas, 1985, 141). This requires the statement of a constraint that encourages a glide /w/ to be fronted:

GLIDE-FRONTING: A glide must be fronted in a morphological derivational process.

In the tableau, candidate (d) violates the glide fronting constraint. Candidate (c) fails to identify the consonantal features of the glide. Candidate (b), which is the outcome of the morphological process of deriving the VN before the phonological processes take place, has a complex onset and a complex coda in violation of the constraint \*COMPLEX. Candidate (a) wins since it resorts to epenthetic vowels to avoid the string of consonant clusters.

(217)

Input: [zwâ : rĕ]	*COMPLEX	GLIDE=ONSET	GLIDE-FRONTING	MAX	DEP
a. → /z <sub>1</sub> i.j <sub>2</sub> α:r <sub>3</sub> αt/					**
b. /z <sub>1</sub> j <sub>2</sub> α:r <sub>3</sub> t/	*!				
c. /z <sub>1</sub> i.i:α:r <sub>3</sub> αt/		*!		*	***
d. /z <sub>1</sub> i.w <sub>2</sub> α:r <sub>3</sub> αt/			*!		

In the following examples 3, 4, and 5, the infixed VN morpheme /a:/ is hosted between C<sub>3</sub> and an infix morpheme /n/ positioned stem-finally. The infixation of /n/ is generally associated with the derivation of certain noun and adjective types, and in the examples below it signifies a semantic meaning of a continuous intensive action or motion (Wright, 2005: Vol. I, 113; Samirrai, 2007, 27). Another point with regards to the glide, which is in the position of C<sub>2</sub>, is that it surfaces with its vocalic features to create a long vowel. Although both syllables of each derived VN are equally heavy, the stress is assigned to the right syllable since the rightmost constraint fulfils the stress preference of the language. Consider the following examples:

3- /C<sub>1</sub>e:C<sub>3</sub>a:n<sub>4</sub>/

Form I trilateral verb

/'m<sub>1</sub>a:l<sub>3</sub>/, 'to lean'

/'ʒ<sub>1</sub>a:b<sub>3</sub>/, 'to bring'

Form I trilateral VN

/m<sub>1</sub>e: 'l<sub>3</sub>a:n<sub>4</sub>/, 'leaning'

/ʒ<sub>1</sub>e: 'b<sub>3</sub>a:n<sub>4</sub>/, 'bringing'

4- /C<sub>1</sub>o:C<sub>3</sub>a:n<sub>4</sub>/

Form I trilateral verb

/ ' d<sub>1</sub>α : x<sub>3</sub>/, 'to be dizzy'

/ ' l<sub>1</sub>a : m<sub>3</sub>/, 'to blame'

Form I trilateral VN

/d<sub>1</sub>o : ' x<sub>3</sub>α : n<sub>4</sub>/, 'dizziness'

/l<sub>1</sub>o : ' m<sub>3</sub>a : n<sub>4</sub>/, 'blaming'

The tableau below illustrates as an example the derivation of the VN /m<sub>1</sub>e : ' l<sub>3</sub>a : n<sub>4</sub>/ from its corresponding verb which has the root consonants √mjl. The MAX constraint accounts for the consonantal features of the root consonants which are usually violated by glides. Thus, candidate (b) is faithful to MAX but it violates the higher ranked constraint which requires glides to surface with their vocalic features. Candidate (c) misplaces the stress. Candidate (a), although it violates the maximality constraint, satisfies the other two high-ranked constraints:

(218)

Input: [mj l â : ñ]	{I, U} = μ	RIGHTMOST	MAX
a. → /m <sub>1</sub> e : ' l <sub>3</sub> a : n <sub>4</sub> /			*
b. /m <sub>1</sub> a j ' l <sub>3</sub> a : n <sub>4</sub> /	*!		
c. / ' m <sub>1</sub> e : l <sub>3</sub> a : n <sub>4</sub> /		*!	

In the following list 5, there are two variants of the VN that are derived from the corresponding verb. The first is similar to the VN type given above. The second is monosyllabic and looks like the corresponding trilateral verb form. However, this cannot be claimed to be a full correspondence derivation, since the grammatical category of each form is different from its correspondence; and the short vowels, although they look alike, have a different functional purpose. Nevertheless, the derived monosyllabic VN gives extra evidence for the minimal prosodic structure which is binary:

5- /C<sub>1</sub>aC<sub>2</sub>C<sub>3</sub>a:n<sub>4</sub>/ or /C<sub>1</sub>aC<sub>2</sub>C<sub>3</sub>/

Form I trilateral verb

/ ' d<sub>1</sub>a f<sub>2</sub> f<sub>3</sub>/, 'to push'

/ ' ʔ<sub>1</sub>α d<sup>ʔ</sup><sub>2</sub> d<sup>ʔ</sup><sub>3</sub>/, 'to bite'

Form I trilateral VN

/d<sub>1</sub>a f<sub>2</sub> ' f<sub>3</sub>a : n<sub>4</sub>/

/ʔ<sub>1</sub>α d<sup>ʔ</sup><sub>2</sub> ' d<sup>ʔ</sup><sub>3</sub>α : n<sub>4</sub>/

$/^1 d_1 a f_2 f_3/$

$/^1 \text{ʕ}_1 \alpha d^{\text{ʕ}}_2 d^{\text{ʕ}}_3/$

$/^1 d_1 a f_2 f_3/$ , ‘pushing’

$/^1 \text{ʕ}_1 \alpha d^{\text{ʕ}}_2 d^{\text{ʕ}}_3/$ , ‘biting’

The only example 6 below that involves prefixation in the derivation of the VN is given as follows. At first, it is not clear whether this VN exhibits infixation or if the long vowel /i:/ is the actual vocalic realization of the underlying glide. The infixational process in deriving the VN so far reveals that the infixated morpheme is the long vowel /a:/. This could lead to treating the long vowel as the surface representation of the underlying glide:

6-  $/m_4 a C_1 i : C_3 - a t/$

Form I trilateral verb

$/^1 \text{ʕ}_1 a : \text{ʕ}_3/$ , ‘to live’

$/^1 k_1 a : d_3/$ , ‘to entrap’

Form I trilateral VN

$/m_4 a ^1 \text{ʕ}_1 i : \text{ʕ}_3 - a t/$ , ‘living’

$/m_4 a ^1 k_1 i : d_3 - a t/$ , ‘trap/set up’

Thus, the derivation of  $/m_4 a ^1 \text{ʕ}_1 i : \text{ʕ}_3 - a t/$ , for example, is derived from the root consonants  $\sqrt{\text{ʕ j ʕ}}$ . But it is surprising to observe the absence of the long vowel morpheme /a:/ since this is the normal infixational morpheme for deriving this noun. For the normal expected infixational process since the glide is the second root consonant, it has to surface with its consonantal features in order to host the long vowel morpheme. That does not happen, and the prefixal morpheme /m/ is identified as the first root consonant for the stem noun. This is evidenced by the existence of the long vowel after the first root consonant, which is identified as the second root consonant of the noun stem. The question is where the morpheme /a:/ has gone and what happens to the glide. The answer relies on the existence of the long vowel /i:/. Because the prefix is identified as the first root consonant of the stem noun, the underlying structure of the noun is represented as  $[\sqrt{m_4 \text{ʕ}_1 a : j_2 \text{ʕ}_3 t}]$ . It seems that there are competing requirements regarding the surfacing of the morpheme /a: / a result of the morphological requirements to preserve this morpheme as well as preserving the identity of the glide, and the phonological requirement which

disfavours that the glide surfaces as a coda in a superheavy syllable. As the optimal form shows, the solution is to preserve the vocalic features of the glide and to preserve the length of the morpheme as well:

(219)

Input: [m̂ʔâ : jʃt̂]	*TRIMORAIC	*DIPH	MAX-C	IDENT-[F]
a. → /m <sub>4</sub> a.ʔ <sub>1</sub> i :.ʃ <sub>3</sub> at/			*	*
b. /m <sub>4</sub> a.ʔ <sub>1</sub> a.i.ʃ <sub>3</sub> at/		*!		
c. /m <sub>4</sub> a.ʔ <sub>1</sub> a : j <sub>2</sub> .ʃ <sub>3</sub> at/	*!			

Candidate (c) is ruled out due to the consonant clusters. The evaluation of the three possible candidates (a), (b), and (c) is based on their vocalic realization the underlying glide. The glide in candidate (c) surfaces with its consonantal features in violation of the constraint that requires glides to surface with their vocalic features. However, the glides in candidates (a) and (b) surface with their vocalic features and are equally moraic. In (a) the glide surfaces as a long vowel, while in (b) it surfaces as a moraic glide. It must be noted that the length of the long vowel and the diphthong is caused by the epenthetic /i/. Since diphthongs are not preferred in this position in the language, the surface of the glide as a vowel shapes the optimal candidate. Thus, candidate (a) wins.

#### 5.3.1.1.1.4 Suffixational Morphemes

The morpheme suffix attached to the derived nouns below is the suffix which designates the noun of one instance. There is no evidence that the initial short vowel is a stem vowel, since there is a diversity of quality in these vowels. However, such diversity could be related to neighbouring consonants, since emphatic and back consonants tend to shape the features of the inserted vowel to back features. Thus, it could be said that the epenthetic vowel is originally /i/, but it acquires the back features of the neighbouring back consonants, for example:

1- /C<sub>1</sub>iC<sub>2</sub>C<sub>3</sub>-at/

Form I trilateral verb

/s<sub>1</sub>a<sup>1</sup> r<sub>2</sub>aḡ<sub>3</sub>/, ‘to steal’

Form I trilateral VN

/<sup>1</sup>s<sub>1</sub>i r<sub>2</sub>ḡ<sub>3</sub>a-t/, ‘stealing/theft’

/g<sub>1</sub>α<sup>1</sup>ʔ<sub>2</sub>αd<sub>3</sub>/, ‘to sit’

/'g<sub>1</sub>iʔ<sub>2</sub>d<sub>3</sub>a-t/ ‘sitting/, a sit’

2- /C<sub>1</sub>uC<sub>2</sub>C<sub>3</sub>-at/

Form I trilateral verb

/d<sub>1</sub>a<sup>1</sup>w<sub>2</sub>e:/, ‘to talk/make noise’

/t<sup>ʔ</sup><sub>1</sub>α<sup>1</sup>l<sub>2</sub>αb<sub>3</sub>/, ‘to ask for sth.’

Form I trilateral VN

/'d<sub>1</sub>uw<sub>2</sub>w<sub>3</sub>a-t/, ‘noise/nonsense’

/'t<sup>ʔ</sup><sub>1</sub>ul<sub>2</sub>b<sub>3</sub>a-t/, ‘asking’

3- /C<sub>1</sub>aC<sub>2</sub>C<sub>3</sub>a-t/

Form I trilateral verb

/d<sub>1</sub>e<sup>1</sup>ʔ<sub>2</sub>e:/, ‘to pray/invite’

/'r<sub>1</sub>α:f<sub>3</sub>/, ‘to be kind’

Form I trilateral VN

/'d<sub>1</sub>aʔ<sub>2</sub>w<sub>3</sub>a-t/, ‘pray/invitation’

/'r<sub>1</sub>o:f<sub>3</sub>a-t/, ‘being kind’

All the derived words share something in common as far as the syllabification process is concerned. The suffix attracts the final root consonant to form an independent syllable, while the initial two root consonants form another syllable of their own. Both syllabification processes are motivated by the requirement to avoid the consonant cluster resulting from the morphological process.

### 5.3.1.1.2 Form II

The Form II trilateral VN is derived from Form II trilateral verbs. Form II trilateral verbs are formed by geminating the second medial root consonant. However, in the derivation of Form II VN, this gemination is not carried over to the VN. The relation between Form II VN and the source of derivation, which is the Form II verb, is semantically established. Both forms denote the intensity or extensiveness of the action which may last continuously for a long time:

1. /t<sub>4</sub>aC<sub>1</sub>C<sub>2</sub>i:C<sub>3</sub>/

This VN pattern is derived from its corresponding Form II trilateral verb, by the prefix /t-/ being augmented to the first root consonant to create an independent syllable; and

the long vowel /i : / being infixes between C<sub>2</sub> and C<sub>3</sub> in the second syllable. Consider the following examples:

Form II trilateral verb

/ 'h<sub>1</sub>ad<sub>2</sub>d<sub>2</sub>ad<sub>3</sub>/, 'to identify'

/ 'x<sub>1</sub>aw<sub>2</sub>w<sub>2</sub>af<sub>3</sub>/, 'to frighten'

Form II trilateral VN

/t<sub>4</sub>aħ<sub>1</sub>' d<sub>2</sub>i : d<sub>3</sub>/, 'identifying'

/t<sub>4</sub>ax<sub>1</sub>' w<sub>2</sub>i : f<sub>3</sub>/, 'frightening'

As an example, the VN /t<sub>4</sub>ax<sub>1</sub>' w<sub>2</sub>i : f<sub>3</sub>/ is formed from the root consonants √xwwf of the correspondent Verb II which yields the underlying form /txwwi : f/. The underlying form contains five root consonants, which is not permitted in the language. In LA, the maximal number of root consonants in a morphological derivational process is four. This may explain the loss of one of the geminated root consonants. The constraint which militates against root consonants to exceed five is given as follows:

\*5 CONSONANTS: in a derivational morphological process root consonants must not exceed five.

Consider the following tableau:

(220)

Input: [t̂xŵwî : f]	*COMPLEX	*5 CONSONANTS	MAX
a. → /t <sub>4</sub> ax <sub>1</sub> .w <sub>2</sub> i : f <sub>3</sub> /			*
b. /t <sub>4</sub> ax <sub>1</sub> .w <sub>2</sub> a.w <sub>2</sub> i : f <sub>3</sub> /		*!	
c. /t <sub>4</sub> x <sub>1</sub> w <sub>2</sub> i : f <sub>3</sub> /	*!		*

The importance of the constraint \*COMPLEX is twofold: firstly it avoids consonant clusters, and secondly makes sure that the root consonants are syllabified. Candidate (c) violates the higher ranked constraint which militates against consonant clusters. The competition between candidates (b) and (a) is settled by the markedness constraint \*5 CONSONANTS which dominates over the faithfulness constraint MAX. Consequently, candidate (a) wins.

2. /t<sub>4</sub>iC<sub>1</sub>C<sub>2</sub>a:C<sub>3</sub>/

The difference between this and the preceding VN is the quality of the VN morpheme, which is in this type represented by the long vowel /a:/. The derivational process is similar to the preceding, but we could add a constraint that shapes the quality of the epenthetic short vowel, for example:

Form II trilateral verb

/<sup>1</sup> ð<sub>1</sub>αk<sub>2</sub>k<sub>2</sub>αr<sub>3</sub>/, ‘to remind’

/<sup>1</sup> m<sub>1</sub>at<sub>2</sub>t<sub>2</sub>al<sub>3</sub>/, ‘to exemplify’

Form II trilateral VN

/t<sub>4</sub>ið<sub>1</sub> <sup>1</sup>k<sub>2</sub>α:r<sub>3</sub>/, ‘souvenir’

/t<sub>4</sub>im<sub>1</sub> <sup>1</sup>t<sub>2</sub>α:l<sub>3</sub>/, ‘idol’

The following type involves the prefixation of /t-/ and the suffixation of /-t/, which is associated with the noun of one instance. It must be noted that, in the language, the suffix /t/ is phonetically realized as /a/ unless it is in the construct state or in connected speech:

3. /t<sub>4</sub>aC<sub>1</sub>C<sub>2</sub>iC<sub>3</sub>-at/

Form II trilateral verb

/<sup>1</sup> ʒ<sub>1</sub>αr<sub>2</sub>r<sub>2</sub>αb<sub>3</sub>/, ‘to try’

/<sup>1</sup> k<sub>1</sub>am<sub>2</sub>m<sub>2</sub>al<sub>3</sub>/, ‘to accomplish’

Form II trilateral VN

/<sup>1</sup> t<sub>4</sub>aʒ<sub>1</sub>r<sub>2</sub>ib<sub>3</sub>-at/, ‘experience/try’

/<sup>1</sup> t<sub>4</sub>ak<sub>1</sub>m<sub>2</sub>il<sub>3</sub>-at/, ‘accomplishment’

The derivational process for /<sup>1</sup>t<sub>4</sub>ak<sub>1</sub>m<sub>2</sub>il<sub>3</sub>-at/ proceeds as follows: the root consonants of the verb √kmm̄l are augmented to the prefix and the suffix, which gives the underlying form /tkmmlt/:

(221)

Input: [t̄k̄m̄ml̄t̄]	*COMPLEX	*5 CONSONANTS	MAX
a. → / <sup>1</sup> t <sub>4</sub> ak <sub>1</sub> .m <sub>2</sub> i.l <sub>3</sub> at/			*
b. / <sup>1</sup> t <sub>4</sub> ak <sub>1</sub> m <sub>2</sub> .l <sub>3</sub> at/	*!		
c. / <sup>1</sup> t <sub>4</sub> ak <sub>1</sub> m <sub>2</sub> .m <sub>2</sub> l <sub>3</sub> at/		*!	



The interesting thing about the winning candidate (a) is the process of syllabification. Each morphological morpheme is hosted in an independent syllable of its own. The stress on the first syllable pushes the segment /m/ either to be augmented as a cluster or otherwise left unparsed. Since these two options are not preferred in the language, an epenthetic /i/ forms a new syllable with /m/ in order to form a well-formed word.

### 5.3.1.1.3 Form III

VNs which are derived from Form III sound verbs have the below structure:

1. /m<sub>4</sub>uC<sub>1</sub>a:C<sub>2</sub>aC<sub>3</sub>-at/

The Form III VN form exhibits the prefix /mu-/. It was claimed earlier that the VN morpheme is generally infixes after the second root consonant C<sub>2</sub>. But in this VN form, the morphology identifies the consonant of the prefix as a root consonant. In this case, the VN morpheme overwrites the morpheme of the Form III verb since both morphemes are specified as a long vowel /a:/. There is support for this claim from the formation of BP. For example, in /d<sub>1</sub>ar<sub>2</sub>as<sub>3</sub>/, ‘he wrote’, /m<sub>4</sub>ad<sub>1</sub>r<sub>2</sub>as<sub>3</sub>-at/, ‘school’ ⇒ /m<sub>4</sub>ad<sub>1</sub>a:r<sub>2</sub>is<sub>3</sub>/, ‘schools’, the prefix /m/ is identified as the second root consonant although the actual second root in the verb form is /r/. This also suggests that the prefix becomes part of the stem and cannot be treated in isolation. Building on this identification of the second root consonant in the Form III VN, the active morphological site in the verb form coincides with the same active morphological site in the VN form. However, two morphemes occupying the same active site at the same time cannot be tolerated by the morphology. Thus, the morpheme of the new derived word, which is here the VN, fills the position of the active site identified by the VN morpheme. Also, this is supported by the fact that the two morphemes identify different grammatical categories: the first identifies Form III in the verb category, while the second identifies Form III in the noun category. The derivation of this VN form also exhibits a suffixation of /t/. The function of the suffix is to mark the noun of one instance which refers to the singulative state of the derived noun. Consider the follow examples:

(222)	Form III trilateral verb	Form III trilateral VN
	/'s <sub>1</sub> a: .ŋ <sub>2</sub> a d <sub>3</sub> /, 'to assist'	/m <sub>4</sub> u. 's <sub>1</sub> a: .ŋ <sub>2</sub> a. d <sub>3</sub> -at/, 'assistance'
	/'ŋ <sub>1</sub> a: .j <sub>2</sub> i n <sub>3</sub> /, 'to examine'	/m <sub>4</sub> u. 'ŋ <sub>1</sub> a: .j <sub>2</sub> a. n <sub>3</sub> -at/, 'examination'

As far as syllabification is concerned, the prefix forms its own light syllable since the vowel is supplied by the morphology. The VN morpheme forms, along with the consonant identified as the second root consonant, a heavy syllable. The suffix is syllabified with C<sub>3</sub> by an epenthetic vowel; otherwise the suffix would create a cluster. Resulting from this syllabification, C<sub>2</sub> is left unparsed since it cannot be parsed either to the preceding syllable or to the following segment which is parsed with the suffix. To syllabify this segment, an epenthetic vowel is inserted creating a light syllable. It must be clear that we are not suggesting any directionality of syllabification, but the main concern is the syllabification process in clusters created by the morphology after the morphological infixational materials have been positioned.

If the VN is derived from a defective verb (the third root consonant is a glide), the stress shifts to the last heavy syllable in obedience to the constraint RIGHTMOST, for example:

(223)	Form III trilateral verb	Form III trilateral VN
	/'ŋ <sub>1</sub> a: n <sub>2</sub> a: /, 'to suffer'	/m <sub>4</sub> uŋ <sub>1</sub> a: 'n <sub>2</sub> a: -t/, 'suffering'
	/'ħ <sub>1</sub> a: d <sub>2</sub> a: /, 'to come close'	/m <sub>4</sub> uħ <sub>1</sub> a: 'd <sub>2</sub> a: -t/, 'coming close'

The tableau shows that the two candidates have each two heavy syllables. Since LA assigns stress from right to left based on the heaviness of syllable weight, and since both candidates have equal syllable weight, candidate (a) wins because it assigns stress on the rightmost syllable:

(224)

Input: [m̂uŋ <sub>1</sub> a: n <sub>2</sub> a: t̂]	RIGHTMOST	NONFINALITY
a. → /m <sub>4</sub> u.ŋ <sub>1</sub> a: . 'n <sub>2</sub> a: t/		*
b. /m <sub>4</sub> u. 'ŋ <sub>1</sub> a: .n <sub>2</sub> a: t/	*!	

2. /C<sub>1</sub>iC<sub>2</sub>a:C<sub>3</sub>/

This pattern is formed by the infixation of the VN morpheme /a:/ between C<sub>2</sub> and C<sub>3</sub>. The long vowel associated with the Form III trilateral verb is not carried over to the VN form. The deletion of the long vowel might be explained as follows. Although both the verb and the VN have the long vowel /a:/, these morphemes have different functions. In the verb, it is associated with the derivation of the Form III trilateral verb, and thus has a verbal function. In the VN, it is associated with the derivation of the Form III trilateral VN, and thus has a noun function. In the derivation of the VN, the grammatical category is assigned as a noun and the long vowel which marks the verb category has lost its function and consequently cannot be transferred to the noun, for example:

(225)	Form III trilateral verb	Form III trilateral VN
	/'ʔ <sub>1</sub> a:l <sub>2</sub> aʒ <sub>3</sub> /, 'to cure'	/ʔ <sub>1</sub> i'l <sub>2</sub> a:ʒ <sub>3</sub> /, 'curing/medicine'
	/'d <sub>1</sub> a:f <sub>2</sub> aʔ <sub>3</sub> /, 'to defend'	/d <sub>1</sub> i'f <sub>2</sub> a:ʔ <sub>3</sub> /, 'defence'

The position of each derivational morpheme occupies a different active morphological site. In the first, it is located after C<sub>1</sub>, while in the second it is after C<sub>2</sub>. This is in fact evidence that each derivational morpheme of each corresponding word carries different morphological information. Consequently, in the derivational morphological process of this VN the derivational morpheme of the input is not carried over to the output derived VN.

#### 5.3.1.1.4 Form IV

In LA, the Form IV trilateral VN is derived from its corresponding Form IV trilateral verbal root consonants. The corresponding verb exhibits an initial prefix glottal stop /ʔ/. This glottal stop is carried over to the derived VN. Consider the following pattern:

1. /ʔ<sub>4</sub>iC<sub>1</sub>C<sub>2</sub>a:C<sub>3</sub>/

The derivation of this pattern is achieved by infixing the VN morpheme /a:/ between C<sub>2</sub> and C<sub>3</sub> of the root consonants. Then, an epenthetic /i/ is inserted to syllabify the first two consonants, for example:

(226) Form IV trilateral verb	Form IV trilateral VN
/ <sup>1</sup> ʔ <sub>4</sub> ɑs <sup>ʔ</sup> <sub>1</sub> d <sub>2</sub> ɑr <sub>3</sub> /, ‘to publish’	/ʔ <sub>4</sub> i s <sup>ʔ</sup> <sub>1</sub> d <sub>2</sub> ɑ : r <sub>3</sub> /, ‘publishing’
/ <sup>1</sup> ʔ <sub>4</sub> an <sub>1</sub> k <sub>2</sub> ɑr <sub>3</sub> /, ‘to deny’	/ʔ <sub>4</sub> i n <sub>1</sub> k <sub>2</sub> ɑ : r <sub>3</sub> /, ‘denying’

If the last consonant in the derived VN is a glide, it is deleted in normal speech. However, it is realized as a glottal stop in the construct state. The deletion of the glide is motivated by the fact that, in LA, glides in the final position surface with their vocalic features. The position of the glide in the VN form is preceded by the VN morpheme /a:/. The glide to surface with its vocalic features in such an environment means that it creates a string of three vowels which is not permitted, for example:

(227) Form IV trilateral verb	Form IV trilateral VN
/ <sup>1</sup> ʔ <sub>4</sub> al <sub>1</sub> q <sub>2</sub> ɑ:/, ‘to give a speech’	/ʔ <sub>4</sub> i l <sub>1</sub> q <sub>2</sub> ɑ:/, ‘addressing’
/ <sup>1</sup> ʔ <sub>4</sub> al <sub>1</sub> ʔ <sub>2</sub> ɑ:/, ‘to cancel’	/ʔ <sub>4</sub> i l <sub>1</sub> ʔ <sub>2</sub> ɑ:/, ‘cancelling’

The derivation of /ʔ<sub>4</sub>i l<sub>1</sub> q<sub>2</sub>ɑ:/ is represented in the follow tableau:

(228)

Input: [ʔ <sub>4</sub> lqâ : j]	*COMPLEX	*__GLIDE] <sub>STEM</sub>	*/vvv/	MAX
a. → /ʔ <sub>4</sub> i l <sub>1</sub> q <sub>2</sub> ɑ:/				*
b. / <sup>1</sup> ʔ <sub>4</sub> l <sub>1</sub> q <sub>2</sub> ɑ:/	*!			
c. /ʔ <sub>4</sub> i l <sub>1</sub> q <sub>2</sub> ɑ : j/		*!		
d. /ʔ <sub>4</sub> i l <sub>1</sub> q <sub>2</sub> ɑ : i/			*!	

What is common in candidates (d) and (c) is that they both have a representation of the glide. The first is vocalic and the second is consonantal. But since a glide in a final position is required by the language to surface with its vocalic root, the constraint \*\_\_GLIDE]<sub>STEM</sub> penalizes any consonantal surfacing of the glide as in candidate (c). The glide in candidate (d) surfaces with its vocalic features, however this creates a string of three vowels which is not permitted in the language. Thus, in this case the constraints \*\_\_GLIDE]<sub>STEM</sub> and \*/vvv/ militate against the realization of the glide in the final position. Candidate (b) is denied due to complex clusters. Candidate (a) is the optimal well-formed candidate since it fulfils all the markedness constraints.

2. /ʔ<sub>4</sub>i 'C<sub>1</sub>a:C<sub>3</sub>-at/

The second pattern of Form IV VN does not correspond to the Form IV verb form. It seems that the input for the derived VN is Form I trilateral verb rather than the Form IV. This is because this verb has at the underlying level a medial glide which surfaces as a long vowel /a:/. For example, the underlying structure of Form IV trilateral verbs /d<sub>1</sub>aw<sub>2</sub>ar<sub>3</sub>/ is /ʔ<sub>4</sub>ad<sub>1</sub>w<sub>2</sub>ar<sub>3</sub>/, and the actual surface structure in CA is /ʔ<sub>4</sub>ad<sub>1</sub>a:r<sub>3</sub>/. It is assumed that, in LA, the Form IV verb /ʔ<sub>4</sub>ad<sub>1</sub>a:r<sub>3</sub>/ undergoes a deletion of the unstressed light syllable which surfaces as what looks like the Form I verb /'d<sub>1</sub>a:r<sub>3</sub>/. However, /d<sub>1</sub>a:r<sub>3</sub>/ cannot be claimed to relate to the Form I trilateral verb, since in the derivation of its Form IV VN the initial glottal stop is retained. Consider the follow examples:

(229)	Form I trilateral verb	Form IV trilateral VN
	/'d <sub>1</sub> a:r <sub>3</sub> /, 'to administrate'	/ʔ <sub>4</sub> i 'd <sub>1</sub> a:r <sub>3</sub> -at/, 'administration'
	/'ʔ <sub>1</sub> a:r <sub>3</sub> /, 'to lend'	/ʔ <sub>4</sub> i 'ʔ <sub>1</sub> a:r <sub>3</sub> -at/, 'lending/borrowing'
	/'m <sub>1</sub> a:l <sub>3</sub> /, 'to lean'	/ʔ <sub>4</sub> i 'm <sub>1</sub> a:l <sub>3</sub> -at/, 'leaning/curving'
	/'z <sub>1</sub> a:l <sub>3</sub> /, 'to demolish'	/ʔ <sub>4</sub> i 'z <sub>1</sub> a:l <sub>3</sub> -at/, 'demolishing'

The long vowels in both the verb and its correspondent VN in each pair are actually the vocalic realization of the underlying glides. Thus, the derivation of all these VNs is suffixational and the long vowel /a:/ must not be confused with the infixational VN morpheme.

### 5.3.1.1.5 Form V

The corresponding Form V VN has an identical structure to that of Form V trilateral verbs. The grammatical category can only be identified in context; otherwise neither the phonology nor the morphology can be used to make the distinction between the two forms based on their surface structures, for example:

(230)	Form V trilateral verb	Form II trilateral VN
	/t <sub>4</sub> a 's <sub>1</sub> at <sub>2</sub> t <sub>2</sub> ar <sub>3</sub> /, 'to cover/hide'	/t <sub>4</sub> a 's <sub>1</sub> at <sub>2</sub> t <sub>2</sub> ar <sub>3</sub> /, 'covering/hiding'
	/t <sub>4</sub> a 'b <sub>1</sub> as <sub>2</sub> s <sub>2</sub> am <sub>3</sub> /, 'to smile'	/t <sub>4</sub> a 'b <sub>1</sub> as <sub>2</sub> s <sub>2</sub> am <sub>3</sub> /, 'smiling'

In CA, however, the two corresponding forms are distinguished by the quality of the vowel in the last syllable of each form. In the verb form the last vowel is /a/, whereas it is /u/ in the VN form. Such vowels are morphologically supplied as derivational morphemes. Because, as assumed earlier, CA is the input for LA, the two corresponding structures have distinctive final vowels in the underlying structure, but at the surface level these vowels appear as /a/ due to phonological constraints that require the fronting of the back vowel /u/.

### 5.3.1.1.6 Form VI

The Form VI VN looks identical to its corresponding Form VI trilateral verb. However, the last short vowel is generally /i/ but in some environments it is recognized as /a/. These environments can be a back consonant, an emphatic vowel, or a bilabial consonant, for example:

(231) Form VI trilateral verb	Form VI trilateral VN
/t <sub>4</sub> a 'g <sub>1</sub> a : t <sub>2</sub> a l <sub>3</sub> /, 'to fight with'	/t <sub>4</sub> a 'g <sub>1</sub> a : t <sub>2</sub> i l <sub>3</sub> /, 'fighting'
/t <sub>4</sub> a 'ʔ <sub>1</sub> α : r <sub>2</sub> α k <sub>3</sub> /, 'to quarrel with'	/t <sub>4</sub> a 'ʔ <sub>1</sub> α : r <sub>2</sub> α k <sub>3</sub> /, 'quarrel'
/t <sub>4</sub> a 's <sup>ʔ</sup> <sub>1</sub> α : d <sub>2</sub> a m <sub>3</sub> /, 'to clash/collide with'	/t <sub>4</sub> a 's <sup>ʔ</sup> <sub>1</sub> α : d <sub>2</sub> a m <sub>3</sub> /, 'clash/collision'

Since C<sub>1</sub> hosts the derivational morpheme to create a heavy syllable, the initial prefix is syllabified as a light syllable while the last two consonants are syllabified as the onset and coda respectively in a new syllable.

### 5.3.1.1.7 Form VII

/ʔi n<sub>4</sub> C<sub>1</sub> i C<sub>2</sub> a : C<sub>3</sub>/

This pattern is derived from the Form VII trilateral verb. The verb form is distinguished by the prefix /n/. In LA, the active participle is sometimes used instead, as in /'m<sub>5</sub>i n<sub>4</sub> ħ<sub>1</sub> a r<sub>2</sub> i f<sub>3</sub>/ and /'m<sub>5</sub>i n<sub>4</sub> ʒ<sub>1</sub> a r<sub>2</sub> i f<sub>3</sub>/ in the examples that follow:

(232)	Form VII trilateral verb	Form VII trilateral VN
	/ʔin <sub>4</sub> ħ <sub>1</sub> a <sup>1</sup> r <sub>2</sub> ɑf <sub>3</sub> /, ‘to lose way’	/ʔin <sub>4</sub> ħ <sub>1</sub> i <sup>1</sup> r <sub>2</sub> ɑ: f <sub>3</sub> /, ‘losing way’
	/ʔin <sub>4</sub> ʒ <sub>1</sub> a <sup>1</sup> r <sub>2</sub> ɑf <sub>3</sub> /, ‘to be driven away’	/ʔin <sub>4</sub> ʒ <sub>1</sub> i <sup>1</sup> r <sub>2</sub> ɑ: f <sub>3</sub> /, ‘being driven away’

The glottal stop associated with the verb and the VN requires some comment. The presence of the glottal stop in both forms prompts the question of whether it is associated with a semantic meaning or inserted by the phonology to break the initial consonant cluster. The morpheme /n/ which is associated with the derivation of Form VII trilateral verb suggests that the glottal stop is epenthetic. This suggestion is motivated by the need to parse this morpheme. Also, /n/ identifies an active morphological site outside the root consonants which in this case is identified as a prefix. That is to say, there is no correspondence relation between the glottal stop of the verb and that of the VN. Both are supplied by the phonology independently and, consequently, the glottal stop is phonologically motivated. Thus, the derivation of the VN is processed by infixing the VN morpheme /a:/ between C<sub>2</sub> and C<sub>3</sub>, and thus the remaining consonants are syllabified. The same account can be given of the pattern /ʔ<sub>4</sub>iC<sub>1</sub>C<sub>2</sub>a:C<sub>3</sub>/ of the Form IV VN. In this pattern, the glottal stop is inserted to break up the initial consonant cluster.

The derivation of /ʔin<sub>4</sub>ħ<sub>1</sub>i<sup>1</sup> r<sub>2</sub>ɑ: f<sub>3</sub>/, for example, is processed as follows: the root consonants of the Form VII trilateral verb plus the morpheme /n/ yield  $\sqrt{\text{hrf} + \text{n-}}$ . Then, this form and the VN morpheme construct the input for the derivation of VN, as can be seen in the following tableau. But first a constraint must be introduced that organizes the adjacency of a prefixal derivational morpheme and a root consonant:

\*PREFIX+ROOT: a prefix must not be syllabified with a root consonant.

(233)

Input: [n̂ħrâ : f]	*COMPLEX	*PREFIX+ROOT
a. → /ʔin <sub>4</sub> .ħ <sub>1</sub> i <sup>1</sup> r <sub>2</sub> ɑ: f <sub>3</sub> /		
b. /ʔin <sub>4</sub> ħ <sub>1</sub> . <sup>1</sup> r <sub>2</sub> ɑ: f <sub>3</sub> /	*!	
c. /n <sub>4</sub> iħ <sub>1</sub> . <sup>1</sup> r <sub>2</sub> ɑ: f <sub>3</sub> /		*!

There is no problem with the placement of the VN morpheme, since it is supplied by the morphology. This morpheme takes C<sub>2</sub> as an onset and C<sub>3</sub> as a coda, creating a heavy syllable. However, syllabifying C<sub>1</sub> and the prefix /n/ reveals a preference in syllabification of derivational consonant morphemes in the language. In the winning candidate, the prefix is syllabified as an independent syllable. The possibility for this prefix to be augmented with C<sub>1</sub> within one syllable is not a choice, as candidate (c) shows. The only choice for C<sub>1</sub> to be syllabified is by an epenthetic /i/ to create an independent syllable; otherwise syllabifying it in either direction would produce a string of consonants. This would violate the anti-cluster constraint \*COMPLEX.

### 5.3.1.1.8 Form VIII

C<sub>1</sub>t<sub>4</sub>iC<sub>2</sub>a:C<sub>3</sub>/

This Form is derived from the Form VIII trilateral verb. The two forms exhibit the infixational morpheme /t/ between C<sub>1</sub> and C<sub>2</sub>, for example:

- |       |   |   |
|-------|---|---|
| (234) | Form VIII trilateral verb   | Form VIII trilateral VN   |
|       | /'ħ <sub>1</sub> t <sub>4</sub> aq <sub>2</sub> αr <sub>3</sub> /, 'to humiliate'     | /ħ <sub>1</sub> t <sub>4</sub> i 'q <sub>2</sub> α:r <sub>3</sub> /, 'humiliation'      |
|       | /'ħ <sub>1</sub> t <sub>4</sub> ak <sub>2</sub> am <sub>3</sub> /, 'to seek judgment' | /ħ <sub>1</sub> t <sub>4</sub> i 'k <sub>2</sub> a:m <sub>3</sub> /, 'seeking judgment' |

The derivation of this VN is similar to that of the Form VII VN. They both syllabify the infixational consonantal morphemes in independent syllables:

(235)

Input: [ħtqâ:r]	*COMPLEX	*PREFIX+ROOT
a. → /ʔiħ <sub>1</sub> .t <sub>4</sub> i.'q <sub>2</sub> α:r <sub>3</sub> /		
b. /ʔiħ <sub>1</sub> t <sub>4</sub> .'q <sub>2</sub> α:r <sub>3</sub> /	*!	
c. /ħ <sub>1</sub> i.t <sub>4</sub> .'q <sub>2</sub> α:r <sub>3</sub> /		*!

As can be seen from the tableau, augmenting /t/ with C<sub>1</sub> in (b) and (c) creates violations to the constraints \*COMPLEX and \*PREFIX+ROOT respectively. The



optimal candidate (a) avoids violating these constraints by syllabifying /t/ and C<sub>1</sub> in separate syllables.

### 5.3.1.1.9 Form IX

/ʔ<sub>4</sub>iC<sub>1</sub>C<sub>2</sub>iC<sub>3</sub>a:C<sub>3</sub>/

This Form is derived from the Form IX trilateral verb. The derivation of this verb is achieved by geminating the third radical root. In deriving the VN, its morpheme /a:/ is hosted between the geminated consonants with respect to the local spreading requirement. Although the VN morpheme separates the two geminated segments, both are still hosted within the same syllable. In MSA (Ryding, 2005, 78), this form has the surface structure as in:

(236) Form IX trilateral verb	Form IX trilateral VN
/ʔ <sub>4</sub> i s <sup>ʕ</sup> <sub>1</sub> f <sub>2</sub> a r <sub>3</sub> r <sub>3</sub> /, ‘to turn yellow’	/ʔ <sub>4</sub> i s <sup>ʕ</sup> <sub>1</sub> f <sub>2</sub> i ' r <sub>3</sub> a : r <sub>3</sub> /, ‘yellowness’
/ʔ <sub>4</sub> i ʔ <sub>1</sub> w <sub>2</sub> a ʔ <sub>3</sub> ʔ <sub>3</sub> /, ‘to crook’	/ʔ <sub>4</sub> i ʔ <sub>1</sub> w <sub>2</sub> i ' ʔ <sub>3</sub> a : ʔ <sub>3</sub> /, ‘crookedness’

In LA, this form is borrowed from CA and is mainly used in the formal language, but generally speaking people tend to use other forms. Hence, the examples are replaced by the forms /s<sup>ʕ</sup><sub>1</sub> a ' f<sub>2</sub> a : r<sub>3</sub>/ and /ʔ<sub>1</sub> a ' w<sub>2</sub> a ʔ<sub>3</sub>/ respectively.

### 5.3.1.1.10 Form X

/s<sub>5</sub>t<sub>4</sub>iC<sub>1</sub>C<sub>2</sub>a:C<sub>3</sub>/

The Form X trilateral verb is distinguished by two prefixes (s-, t-) augmented respectively to the root consonants. Interestingly, the two prefixes are not joined within one syllable either in the verb or in the noun forms. The first prefix is syllabified in a coda position in an independent syllable where a vowel and a glottal stop are epenthesized to produce a well-formed syllable, while the second prefix forms another syllable with the first root consonant, for example:

(237) Form X trilateral verb	Form X trilateral VN
/s <sub>5</sub> ' t <sub>4</sub> ak <sub>1</sub> m <sub>2</sub> il <sub>3</sub> /, 'to accomplish'	/s <sub>5</sub> t <sub>4</sub> ik <sub>1</sub> ' m <sub>2</sub> a:l <sub>3</sub> /, 'accomplishing'
/s <sub>5</sub> ' t <sub>4</sub> an <sub>1</sub> ʒ <sub>2</sub> id <sub>3</sub> /, 'to call for help'	/s <sub>5</sub> t <sub>4</sub> in <sub>1</sub> ' ʒ <sub>2</sub> a:d <sub>3</sub> /, 'calling for help'

As a consequence of identifying the active morphological site according to the VN morpheme which takes C<sub>2</sub> and C<sub>3</sub> as its components of a well-formed syllable, the syllabification process has to parse the unparsed C<sub>1</sub> and the prefixes C<sub>4</sub> and C<sub>5</sub>. However, the syllabification process has to respect the way the language parses affixes. The constraint \*PREFIX+ROOT has already been introduced. There is another constraint, we suggest, which militates against the augmentation of two affixes within one syllable. The constraint is defined as follows:

\*AFFIX+AFFIX: two affixes must not be parsed within the same syllable.

Satisfying both constraints is not possible. This is because the only way to satisfy them is to parse the unparsed segments in three syllables, two of which are consecutive light syllables. Since the language tends to reduce any string of light syllables, one of the constraints has to be ranked lower than the other. Let us take /s<sub>5</sub>t<sub>4</sub>ik<sub>1</sub>' m<sub>2</sub>a:l<sub>3</sub>/ in accounting for the constraints at work in its derivation:

(238)

Input: [ŝf̂kmâ:l]	*AFFIX+AFFIX	*CvCv	*PREFIX+ROOT	DEP
a. → /ʔis <sub>5</sub> .t <sub>4</sub> ik <sub>1</sub> .' m <sub>2</sub> a:l <sub>3</sub> /			*	***
b. /s <sub>5</sub> it <sub>4</sub> .k <sub>1</sub> i.' m <sub>2</sub> a:l <sub>3</sub> /	*!	*		**
c. /ʔis <sub>5</sub> .t <sub>4</sub> i.k <sub>1</sub> i.' m <sub>2</sub> a:l <sub>3</sub> /		**!	*	****

In the tableau, the three possible candidates show diversity in syllabifying the initial segments. The motivation to rank \*AFFIX+AFFIX at the top leads parsing the first segment independently; otherwise the other parsing options push the segments to be syllabified into light syllables. Therefore, the constraint \*CvCv must be equally ranked with the top constraint to eliminate light syllables. Satisfying these two constraints rules out candidates (c) and (b). Nevertheless, the price of such a satisfaction of the top constraints leads to a violation of \*PREFIX+ROOT by candidate (a). In order for (a) to win, \*PREFIX+ROOT must

be ranked lower than the top constraints. These possible syllabifications of segments can only be achieved by ranking the constraint DEP very low in order to allow for epenthetic segments to produce the well-formed syllabification favoured by the language.

The structure of the noun of one instance is derived by the suffixation /-t/ which is augmented to the Form X VN. The syllabification is similar to that in Form X VN, but the last segment is adjoined to the suffix to create a new syllable, for example:

/s<sub>5</sub>t<sub>4</sub>iC<sub>1</sub>C<sub>2</sub>a:C<sub>3</sub>a-t/

(239)	Form X trilateral verb	Form X trilateral VN
	/s <sub>5</sub> t <sub>4</sub> a 'ħ <sub>1</sub> a:l <sub>3</sub> /, 'to be impossible'	/s <sub>5</sub> t <sub>4</sub> i 'ħ <sub>1</sub> a:l <sub>3</sub> -at/, 'impossibility'
	/s <sub>5</sub> t <sub>4</sub> a 'ŋ <sub>1</sub> a:d <sub>3</sub> /, 'to bring back'	/s <sub>5</sub> t <sub>4</sub> i 'ŋ <sub>1</sub> a:d <sub>3</sub> -at/, 'returning back'

### 5.3.1.2 Quadrilateral VN

In quadrilateral VN forms, there are four root consonants. These are either genuinely distinct or duplicated root consonants. The morphology of this VN exhibits internal and external affixations and in some cases both affixational processes take place in the underlying morphological process. Consider the following quadrilateral VN forms:

a- /C<sub>1</sub>aC<sub>2</sub>C<sub>3</sub>aC<sub>4</sub>a-t/

(240)	/'t <sub>1</sub> a r <sub>2</sub> ʒ <sub>3</sub> a m <sub>4</sub> /, 'to translate'	/'t <sub>1</sub> a r <sub>2</sub> ʒ <sub>3</sub> a m <sub>4</sub> -at/, 'translation'
	/'f <sub>1</sub> a r <sub>2</sub> g <sub>3</sub> a ŋ <sub>4</sub> /, 'to explode'	/'f <sub>1</sub> a r <sub>2</sub> g <sub>3</sub> a ŋ <sub>4</sub> -at/, 'explosion'

The surface structure of this form represents the preference in syllabification for this form. Due to the fact that, in the underlying structure, the segments are parsed into a CV syllable structure, the underlying structure of the well-formed structure for /t<sub>1</sub>a r<sub>2</sub>ʒ<sub>3</sub>a m<sub>4</sub>at/, for example, is possibly /t<sub>1</sub>a.r<sub>2</sub>a.ʒ<sub>3</sub>a.m<sub>4</sub>at/. In fact, the surface structure is motivated by the stress assignment of the language which favours stress falling on a heavy syllable:

(241)

Input: [tarazamat]	*CV] <sub>σ</sub>	MAX-IO
a. → /'t <sub>1</sub> ar <sub>2</sub> .ʒ <sub>3</sub> a.m <sub>4</sub> at/	*	*
b. /'t <sub>1</sub> a.r <sub>2</sub> a.ʒ <sub>3</sub> a.m <sub>4</sub> at/	***!	

There is no way for the faithful candidate (b) to surface, since it contains a string of consecutive light syllables. Candidate (a) wins because it minimally violates the top-ranked constraint, even though it violates the low-ranked constraint.

b- /t<sub>5</sub>aC<sub>1</sub>aC<sub>2</sub>C<sub>3</sub>i :C<sub>4</sub>/

(242) /'z<sub>1</sub>al<sub>2</sub>b<sub>3</sub>aħ<sub>4</sub>/, 'to fool sb.'                      /t<sub>5</sub>az<sub>1</sub>al<sub>2</sub>'b<sub>3</sub>i :ħ<sub>4</sub>/, 'fooling'  
/ 'x<sub>1</sub>as<sup>ɛ</sup><sub>2</sub>x<sub>3</sub>as<sup>ɛ</sup><sub>4</sub>/, 'to privatize'                      /t<sub>5</sub>ax<sub>1</sub>as<sup>ɛ</sup><sub>2</sub>'x<sub>3</sub>i :s<sup>ɛ</sup><sub>4</sub>/, 'privatizing'

In this form, there are two affixational morphemes: the external morpheme prefix /t/ and the infixational morpheme /i :/ which is hosted between C<sub>3</sub> and C<sub>4</sub>. Both morphemes fill the active morphological sites for this form. The actual underlying surface form /t<sub>5</sub>az<sub>1</sub>al<sub>2</sub>'b<sub>3</sub>i :ħ<sub>4</sub>/, for instance, is represented as /t<sub>5</sub>a.z<sub>1</sub>a.l<sub>2</sub>a.'b<sub>3</sub>i :ħ<sub>4</sub>/ in which each segment is syllabified as a light syllable apart from the last two segments which are syllabified in a heavy syllable since the VN vowel morpheme is bimoraic. The prefixal morpheme is syllabified as a light syllable due to the preference of the language to parse such segments which are isolated from the root segments. Within the root segments, the syllabification process requires the reduction of the number of light syllables. Thus, the short vowel associated with the second root segment is truncated, creating a heavy closed syllable.

c- /C<sub>1</sub>(v)C<sub>2</sub>C<sub>3</sub>a :C<sub>4</sub>/

The VN vowel morpheme /a :/ of this form fills the active morphological site hosted between C<sub>3</sub> and C<sub>4</sub>. Although the syllabification of the root segments is similar to that in the preceding form, the initial epenthetic vowel is constrained as /i/ except, it seems, in some environments where it surfaces as /u/ as in the following examples:

- (243) /'z<sub>1</sub>a<sub>1</sub>l<sub>2</sub>z<sub>3</sub>a<sub>1</sub>l<sub>4</sub>/, 'to be shaken repeatedly'      /z<sub>1</sub>i<sub>1</sub>l<sub>2</sub>'z<sub>3</sub>a:l<sub>4</sub>/, 'earthquake'  
 /'ɣ<sub>1</sub>ɑ<sub>r</sub><sub>2</sub>b<sub>3</sub>a<sub>1</sub>l<sub>4</sub>/, 'to sieve'      /ɣ<sub>1</sub>i<sub>r</sub><sub>2</sub>'b<sub>3</sub>a:l<sub>4</sub>/, 'sieve'  
 /'b<sub>1</sub>ɑ<sub>r</sub><sub>2</sub>h<sub>3</sub>ɑ<sub>n</sub><sub>4</sub>/, 'to give evidence'      /b<sub>1</sub>u<sub>r</sub><sub>2</sub>'h<sub>3</sub>ɑ:n<sub>4</sub>/, 'evidence'

d- /t<sub>5</sub>aC<sub>1</sub>aC<sub>2</sub>C<sub>3</sub>aC<sub>4</sub>/

The prefix in this form behaves like the previously mentioned cases. It is syllabified as an independent light syllable separated from the root segments. The syllabification process of the root segments fulfils the requirement to reduce the number of light syllables. Thus, the short vowel associated with the second root segments is deleted creating with the preceding segment a heavy closed syllable, for example:

- (244) /'s<sub>1</sub>a<sub>1</sub>l<sub>2</sub>s<sub>3</sub>a<sub>1</sub>l<sub>4</sub>/, 'to chain'      /t<sub>5</sub>a's<sub>1</sub>a<sub>1</sub>l<sub>2</sub>s<sub>3</sub>a<sub>1</sub>l<sub>4</sub>/, 'serial'  
 /'x<sub>1</sub>a<sub>1</sub>l<sub>2</sub>x<sub>3</sub>a<sub>1</sub>l<sub>4</sub>/, 'to shake'      /t<sub>5</sub>a'x<sub>1</sub>a<sub>1</sub>l<sub>2</sub>x<sub>3</sub>a<sub>1</sub>l<sub>4</sub>/, 'shaking'

## 5.4 Instance Nouns

These nouns refer to the occurrence of one action described by the VN. The structure of the instance noun is achieved by the addition of the /-t/ suffix to the VN stem. They have the following forms:

a- /C<sub>1</sub>aC<sub>2</sub>C<sub>3</sub>a-t/

- |       |  |  |
|-------|--|--|
| (245) | VN Form  | Instant Noun   |
|       | /'d <sup>ʔ</sup> <sub>1</sub> ɑ <sub>r</sub> <sub>2</sub> ɑ <sub>b</sub> <sub>3</sub> /, 'hitting' | /'d <sup>ʔ</sup> <sub>1</sub> ɑ <sub>r</sub> <sub>2</sub> b <sub>3</sub> -at/, 'a hit' |
|       | /'r <sub>1</sub> ɑ <sub>f</sub> <sub>2</sub> ɑ <sub>f</sub> <sub>3</sub> /, 'lifting'              | /'r <sub>1</sub> ɑ <sub>f</sub> <sub>2</sub> f <sub>3</sub> -at/, 'a lift'             |

b- /C<sub>1</sub>iC<sub>2</sub>C<sub>3</sub>a-t/

- |       |   |   |
|-------|---|---|
| (246) | /'ħ <sub>1</sub> i <sub>1</sub> l <sub>2</sub> i <sub>m</sub> <sub>3</sub> /, 'dream' | /'ħ <sub>1</sub> i <sub>1</sub> l <sub>2</sub> m <sub>3</sub> -at/, 'a dream' |
|       | /'k <sub>1</sub> i <sub>1</sub> ð <sub>2</sub> i <sub>b</sub> <sub>3</sub> /, 'lie'   | /'k <sub>1</sub> i <sub>1</sub> ð <sub>2</sub> b <sub>3</sub> -at/, 'a lie'   |



/<sup>1</sup>x<sub>1</sub>ub<sub>2</sub>uz<sub>3</sub>/, ‘bread’

/<sup>1</sup>x<sub>1</sub>ub<sub>2</sub>z<sub>3</sub>-at/, ‘a loaf’

b- /C<sub>1</sub>vC<sub>2</sub>C<sub>3</sub>vvC<sub>4</sub>a-t/

(250) Collective Noun

/m<sub>1</sub>iʃ<sub>2</sub><sup>1</sup>m<sub>3</sub>a:ʃ<sub>4</sub>/, ‘apricots’

/t<sub>1</sub>i f<sub>2</sub><sup>1</sup>f<sub>3</sub>a:h<sub>4</sub>/, ‘apples’

Unit Noun

/m<sub>1</sub>iʃ<sub>2</sub><sup>1</sup>m<sub>3</sub>a:ʃ<sub>4</sub>-at/, ‘an apricot’

/t<sub>1</sub>i f<sub>2</sub><sup>1</sup>f<sub>3</sub>a:h<sub>4</sub>-at/, ‘an apple’

## 5.6 Feminine Nouns

The general derivational rule that derives some feminine nouns from their corresponding masculine nouns is the feminine morpheme suffix /-t/ realized as /a/ in a pause. However, some nouns are considered feminine without having this suffix, as in /ʃ<sub>1</sub>am<sub>2</sub>iʃ<sub>3</sub>/, ‘sun’ and /s<sub>1</sub>am<sub>2</sub>e:/, ‘sky’, for example:

(251) Masculine Nouns

/<sup>1</sup>k<sub>1</sub>a l<sub>2</sub>b<sub>3</sub>/, ‘dog’

/s<sup>ʔ</sup><sub>1</sub>α<sup>1</sup> d<sub>2</sub>i:q<sub>3</sub>/, ‘friend’

Feminine Nouns

/<sup>1</sup>k<sub>1</sub>a l<sub>2</sub>b<sub>3</sub>-at/

/s<sup>ʔ</sup><sub>1</sub>α<sup>1</sup> d<sub>2</sub>i:q<sub>3</sub>-at/

As with parsing suffixes, a consonantal suffix creates a cluster if it is augmented to a preceding root consonant. To avoid such a cluster, an epenthetic vowel is inserted between the suffix and the last root consonant, as illustrated in the tableau:

(252)

Input: [k <sub>1</sub> a l <sub>2</sub> b <sub>3</sub> t̪]	*COMPLEX	DEP
a. → / <sup>1</sup> k <sub>1</sub> a l <sub>2</sub> .b <sub>3</sub> at/		*
b. / <sup>1</sup> k <sub>1</sub> a l <sub>2</sub> b <sub>3</sub> t/	*!	

The low-ranked constraint DEP allows candidate (a) to avoid the consonant cluster by inserting a vowel, whereas candidate (b) is denied by the higher ranked constraint militating against clusters.





## 5.8 Instrumental Nouns

These nouns refer to the tools by which the action of the verb is carried out. The derivational morpheme for this noun is the prefixal morpheme /m/, and in some forms the internal morpheme /a:/ and the suffixal morpheme /t/ are also activated in their associated active morphological sites, for example:

a- /m<sub>4</sub>aC<sub>1</sub>C<sub>2</sub>aC<sub>3</sub>/

- |       |  |  |
|-------|--|--|
| (256) | /s <sub>1</sub> a <sup>1</sup> n <sub>2</sub> a d <sub>3</sub> /, ‘to support’       | / <sup>1</sup> m <sub>4</sub> a s <sub>1</sub> n <sub>2</sub> i d <sub>3</sub> /, ‘support device’ |
|       | /ʃ <sub>1</sub> a <sup>1</sup> b <sub>2</sub> a k <sub>3</sub> /, ‘to join together’ | / <sup>1</sup> m <sub>4</sub> a ʃ <sub>1</sub> b <sub>2</sub> i k <sub>3</sub> /, ‘clipper’        |

b- /m<sub>4</sub>aC<sub>1</sub>C<sub>2</sub>a:C<sub>3</sub>/

- |       |   |  |
|-------|---|--|
| (257) | /f <sub>1</sub> a <sup>1</sup> t <sub>2</sub> a ħ <sub>3</sub> /, ‘to open’ | /m <sub>4</sub> a f <sub>1</sub> <sup>1</sup> t <sub>2</sub> a : ħ <sub>3</sub> /, ‘key’   |
|       | / <sup>1</sup> g <sub>1</sub> a : s <sub>3</sub> /, ‘to measure’            | /m <sub>4</sub> a g <sub>1</sub> <sup>1</sup> j <sub>2</sub> a : s <sub>3</sub> /, ‘scale’ |

c- /m<sub>4</sub>aC<sub>1</sub>C<sub>2</sub>C<sub>3</sub>a-t/

- |       |   |   |
|-------|---|---|
| (258) | /k <sub>1</sub> a <sup>1</sup> n <sub>2</sub> a s <sub>3</sub> /, ‘to sweep’                | / <sup>1</sup> m <sub>4</sub> a k <sub>1</sub> n <sub>2</sub> s <sub>3</sub> -a-t/, ‘broom’                 |
|       | /ʔ <sub>1</sub> a <sup>1</sup> s <sup>ʔ</sup> <sub>2</sub> a r <sub>3</sub> /, ‘to squeeze’ | / <sup>1</sup> m <sub>4</sub> a ʔ <sub>1</sub> s <sup>ʔ</sup> <sub>2</sub> r <sub>3</sub> -a-t/, ‘oil mill’ |

In (a) and (b), the prefixal and infixal derivational morphemes are syllabified in bisyllabic structures. The syllabification of the suffix in (c), in fact, creates a trisyllabic structure, where C<sub>2</sub> is initially syllabified in a light syllable. The light syllable trapped between two heavy syllables loses its vowel, which can be attributed to the preference for avoiding light syllables in such a position, causing the preceding syllable to be a superheavy syllable. This is a normal case of semi-syllable structures allowed in the language, as previously showed in section 4.3.3.

## 5.9 Occupational Nouns

An occupational noun denotes the profession of a person. There are two main patterns for such nouns: the first is derived by the gemination of the second radical root and the VN morpheme is infixed between the second segment of the gemination and the last radical root; and the second pattern takes the form of the active participle whose morpheme /a:/ is inserted between the first and second radical roots. If the derived noun denotes the feminine gender, then the feminine morpheme /t/ is suffixed, for example:

1. /C<sub>1</sub>aC<sub>2</sub>C<sub>2</sub>a:C<sub>3</sub>/ and its feminine /C<sub>1</sub>aC<sub>2</sub>C<sub>2</sub>a:C<sub>3</sub>a-t/

(259)	Verb Form	Masculine	Feminine
	/x <sub>1</sub> α' b <sub>2</sub> αz <sub>3</sub> /, 'to bake'	/x <sub>1</sub> αb <sub>2</sub> ' b <sub>2</sub> α:z <sub>3</sub> /	/x <sub>1</sub> αb <sub>2</sub> ' b <sub>2</sub> α:z <sub>3</sub> -at/, 'baker'
	/' <sub>1</sub> sα:g <sub>3</sub> /, 'to drive'	/s <sub>1</sub> aw <sub>2</sub> ' w <sub>2</sub> α:g <sub>3</sub> /	/s <sub>1</sub> aw <sub>2</sub> ' w <sub>2</sub> α:g <sub>3</sub> -at/, 'driver'

2. /C<sub>1</sub>a:C<sub>2</sub>iC<sub>3</sub>/ and its feminine /C<sub>1</sub>a:C<sub>2</sub>C<sub>3</sub>a-t/

(260)	Verb Form	Masculine	Feminine
	/ʔ <sub>1</sub> a' m <sub>2</sub> al <sub>3</sub> /, 'to work'	/' <sub>1</sub> ʔ <sub>1</sub> a:m <sub>2</sub> il <sub>3</sub> /	/' <sub>1</sub> ʔ <sub>1</sub> a:m <sub>2</sub> l <sub>3</sub> -at/, 'worker'
	/t <sub>1</sub> α' l <sub>2</sub> ab <sub>3</sub> /, 'to ask'	/' <sub>1</sub> t <sub>1</sub> α:l <sub>2</sub> ib <sub>3</sub> /	/' <sub>1</sub> t <sub>1</sub> α:l <sub>2</sub> b <sub>3</sub> -at/, 'student'

## 5.10 Diminutive Nouns

This type of noun denotes smallness or endearment (Ryding, 2005, 90). These nouns are derived from nouns or adjectives, and the diminutive marker /j/ occupies the position between C<sub>2</sub> and C<sub>3</sub>, and takes the surface forms /aj/ or /e:/, for example:

1. Masculine /C<sub>1</sub>C<sub>2</sub>aj<sub>4</sub>j<sub>5</sub>iC<sub>3</sub>/, Feminine /C<sub>1</sub>C<sub>2</sub>aj<sub>4</sub>C<sub>3</sub>a-t/

(261)		Masculine	Feminine
	/r <sub>1</sub> a' ħ <sub>2</sub> i:m <sub>3</sub> /, 'kind'	/r <sub>1</sub> ' ħ <sub>2</sub> aj <sub>4</sub> j <sub>5</sub> im <sub>3</sub> /	/r <sub>1</sub> ' ħ <sub>2</sub> aj <sub>4</sub> m <sub>3</sub> -at/
	/s <sub>1</sub> e' m <sub>2</sub> i:n <sub>3</sub> /, 'fat'	/s <sub>1</sub> ' m <sub>2</sub> aj <sub>4</sub> j <sub>5</sub> in <sub>3</sub> /	/s <sub>1</sub> ' m <sub>2</sub> aj <sub>4</sub> n <sub>3</sub> -at/

2. Masculine /C<sub>1</sub>w<sub>4</sub>e:C<sub>2</sub>iC<sub>3</sub>/, Feminine /C<sub>1</sub>w<sub>4</sub>e:C<sub>2</sub>C<sub>3</sub>a-t/

(262)		Masculine	Feminine
	/ <sup>1</sup> f <sub>1</sub> a:l <sub>2</sub> iḥ <sub>3</sub> /, ‘clever’	/f <sub>1</sub> <sup>1</sup> w <sub>4</sub> e:l <sub>2</sub> iḥ <sub>3</sub> /	/f <sub>1</sub> <sup>1</sup> w <sub>4</sub> e:l <sub>2</sub> ḥ <sub>3</sub> -at/
	/ <sup>1</sup> k <sub>1</sub> a:t <sub>2</sub> ib <sub>3</sub> /, ‘writer’	/k <sub>1</sub> <sup>1</sup> w <sub>4</sub> e:t <sub>2</sub> ib <sub>3</sub> /	/k <sub>1</sub> <sup>1</sup> w <sub>4</sub> e:t <sub>2</sub> b <sub>3</sub> -at/

### 5.11 Inflection

Nouns inflect for gender, humanness, number, definiteness, and case. The features of gender and humanness are inherent in the noun. The features of number and definiteness are specified semantically by the reference nature of the noun within a context, and the feature case is specified by the syntactic role of the noun within a phrase structure (Ryding, 2005, 119). There is no neutral assignment in Arabic nouns. Nouns are either masculine or feminine. Gender is assigned in natural environments where natural gender is distinguished as in the natural gender of a human being or that of creatures. Otherwise, the assigning of gender category seems semantically to be random. For example, /<sup>1</sup>ʃ<sub>1</sub>am<sub>2</sub>iʃ<sub>3</sub>/, ‘sun’, is considered feminine and /g<sub>1</sub>α<sup>1</sup>m<sub>2</sub>ar<sub>3</sub>/, ‘moon’, is considered masculine, although neither are assigned naturally to gender. Masculine is unmarked in nouns whereas feminine is marked by the suffix /-t/ which is realized as /-a/ or /-h/ in a pause. Because Arabic does not distinguish neutral gender category, nouns are assigned to either masculine or feminine. Nevertheless, Arabic makes a morpho-semantic feature distinction as to whether a noun refers to a human or not. This distinction is very important in the formation of some plural forms and also for marking agreement within the phrase or the clause. This human feature applies only to nouns in the plural (Ryding, 2005:125). Thus, if the plural noun has a non-human referent it receives feminine singular agreement, as in:

(263)	/ʔil-diʃa:b	ʔil-ʒa:jʔ-at/
	‘The-wolf + plural	the-hungry’ feminine + singular
	‘The hungry wolves’	
	/fi-l-ʔija:m	l-fa:jt-at/
	‘In-the-day (plural)	the-passed’ feminine + singular

‘In the last days’

If the plural noun has a human reference, however, the noun distinguishes whether it takes masculine or feminine gender and it has to trigger number agreement with the other components of the phrase or the clause, as in:

(264) /ʔil-rʒa:l      ʔil-ma:ʃj-i:n      ʔale: riʒle:-hum/  
‘The-man (plural)    the-walking (plural)    on      feet-their’  
‘The men who are walking on foot’

/ʔil-bant-a:t      ʔil-zajr-ɑ:t/  
‘The- girl (plural)      the-visiting’ plural  
‘The visiting girls’

Interestingly, only nouns that denote human beings take the sound masculine plural. Furthermore, there are some broken plural patterns restricted to human beings (Ryding, 2005, 128), as in:

(265) /CuCaCa:ʔ/  
/ra' ʔi:s/, ‘a president’      ⇒      /ruʔa' sa:ʔ/, ‘presidents’  
  
/ʔaCCiCa:ʔ/  
/sʕɑ'di:q/, ‘a friend’      ⇒      /ʔasʕdi' qɑ:ʔ/, ‘friends’  
  
/CuCCa:C/  
/tʕɑ:lib/, ‘a student’      ⇒      /tʕul' lɑ:b/, ‘students’

As far as number marking is concerned, nouns in Arabic are marked for number by three number markers: singular, dual, and plural. Singular is marked by the suffix /t/ which is realized as /a/ in a pause as in the following examples:

(266)	Count Noun	Mass Noun
	/ma 'di :n-a/, 'city'	/' rɔml-a/, 'sand'

For both masculine and feminine nouns, the dual morpheme /-e :n/ suffix is added:

(267)	Singular Noun	Dual Noun
	/' ħo :ʃ/, 'house'	/ħo : 'ʃe :n/, 'two houses'
	/' madrsa-t/, 'school'	/madris 'te :n/, 'two schools'

In LA, the plural is used instead of dual except in situations of emphasis. Furthermore, the derivation of the dual can be arrived at by the usage of /'zo :z/, means a pair, before plural nouns:

(268) /'zo :z te 'ri :s/, 'two men'

LA distinguishes two types of plurals: SP and BP. In SP, it distinguishes MSP and FSP. MSP refers generally to male human beings. In addition, any group of people, even if the majority are feminine, that includes at least one male is referred to by the sound masculine. The inflectional suffix for this type is /-i :n/ in the genitive case and /-u :n/ in the nominative case. The examples given below are in the genitive case because speakers of LA tend to over-generalize /-i :n/:

(269)	/mu 'ʔallim/, 'teacher'	⇒	/muʔalli 'mi :n/, 'teachers'
	/xɔb 'bɔ :z/, 'baker'	⇒	/xɔbbɔ : 'zi :n/, 'bakers'

The formation of FSP is achieved by suffixing the feminine morpheme plural /-a :t/ to the singular:

(270)	Singular Noun	Feminine Sound Plural
	/ʃa :bb-at/, 'young girl'	/ʃa :bb-a :t/
	/t <sup>ʕ</sup> ɔ :lib-at/, 'student fem.'	/t <sup>ʕ</sup> ɔ :lib-a :t/

It is generally assumed that the pluralization process of SP does not affect the stem. However, there is a phonological process of deleting unstressed short vowels associated with the formation of SP, as follows:

(271)	Base form + suffix	MSP
	/muslim+i:n/, 'Muslim'	/musilmi:n/

The example suggests that the stem is subject to phonological processes as a result of SP derivation. This is contrary to the claim by Ratcliffe (1990) that the phonological processes in Level II morphology occur externally to the stem.

## 5.12 Conclusion

The correspondence relations between the derived noun and its source of derivation, whatever its assumed source, has shown that they, in fact, do not stand in complete correspondence. The morphological process of the derived noun make reference only to the root consonants and it has never been the case that the phonological elements are carried over to the derived word or even show any faithfulness relation between the derived output and its corresponding source of derivation. The derivation of nouns shows that the root consonants plus the derivational morphemes of the noun represent the underlying structure of the derived noun. The discussion of the morphological process started by identifying the root consonants and the target derivational morphemes. These together form the underlying structure of the derived noun. Then, at the surface level, the phonological constraints repair any ill-formed structure. As was shown, the underlying structure of the derived noun surface as a possible candidate. However, although it shows complete faithfulness to the input, it fails to satisfy the active phonological constraints of the language. Because the underlying structure is the result of an associated morphological process which usually has a string of consonant clusters, any underlying form has to satisfy the constraint \*COMPLEX in order to surface. Without any doubt, this is the first and one of the top-ranked constraints in checking the structure of the underlying form. Its function is twofold; to force syllabification and to avoid consonant clusters at the surface level. The non-concatenative morphology of nouns demonstrates the actual morphophonological operations that are required to reconstruct new words in LA.

Similar to the account given of derived nouns, the following chapter shows that the derivation of adjectives tracks the same path as that of nouns. The only difference is actually the type of derivational morphemes which distinguish the adjective from the noun.

## **Chapter 6: Non-concatenative Derived Adjectives in LA**

This chapter continues along the lines of what has been suggested for the derivation of nouns. The only difference, of course, is the type of adjectival morphemes. In the first place, the derivation of adjectives from corresponding root consonants is accounted for with a focus also on the derivation of participles. Then, the inflectional processes related to the formation of BP are explained.

### **6.1 Adjectives Derived from Triliteral Roots**

In the follow examples which are associated with the derivation of adjectives from triliteral root consonants, the singular adjectives are given as if they are derived from a corresponding verb form. Although it is assumed that the morphological derivational process for adjectives also involves the root consonants plus a specific adjectival marker which is positioned in the active morphological site, the singular adjective forms are given for illustration, and whether the adjective is derived from Form I or Form II triliteral root verbs is always open to question. This is similar to the situation with the derivation of nouns discussed in the previous chapter. In fact, there is no obvious correspondence relation between the input ‘verb’ and the output adjective form. For example, the existence of a doubled medial root consonant in the adjective does not necessarily mean that the adjective is derived from a corresponding Form II triliteral verb. Similarly, many derived adjectives have only Form II correspondent verbs, but the doubled medial root consonant is not carried over to the derived adjective. Also, some adjectives are derived by the vowel morphemes only, which, in other words, mean that the vowels have a morphological function which is triggered by the morphological derivational process of adjectives. Thus, the corresponding given verb form could be treated as evidence against any complete correspondence relation between the input and the output derived word. Consider the following examples:



a. /C<sub>1</sub>aC<sub>2</sub>i:C<sub>3</sub>/

- (272) /n<sub>1</sub>ǎ<sup>ǎ</sup><sub>2</sub>ǎf<sub>3</sub>/, ‘to become clean’                      /n<sub>1</sub>aǎ<sup>ǎ</sup><sub>2</sub>i:f<sub>3</sub>/, ‘clean’  
           /s<sub>1</sub>m<sub>2</sub>i n<sub>3</sub>/, ‘to be fat’                                        /s<sub>1</sub>am<sub>2</sub>i:n<sub>3</sub>/, ‘fat’

This adjective form is derived from the string of root consonants and the adjectival morpheme /i:/ which is hosted in the active morphological site after C<sub>2</sub> of the adjective form. This long vowel denotes a specific meaning in this adjective form which refers to the constant characteristics being described by the adjective form, whether these characteristics are given by nature or are acquired. The morphological derivational process of this adjective is as follows: the root consonants √nǎ<sup>ǎ</sup>f plus the adjectival morpheme /i:/ are positioned in the active morphological site after C<sub>2</sub>, which gives the underlying structure √nǎ<sup>ǎ</sup>i:f. Since this structure has an initial consonant cluster, the phonology repairs it by the force of the constraint \*COMPLEX.

In (b) and (c) below, the active morphological site of the adjective is identified by the initial vowel; the second vowel is supplied by the phonology:

b. /C<sub>1</sub>aC<sub>2</sub>C<sub>3</sub>/

- (273) /ǎ<sub>1</sub>aǎ<sub>2</sub>ab<sub>3</sub>/, ‘to attract’                                        /ǎ<sub>1</sub>aǎ<sub>2</sub>b<sub>3</sub>/, ‘attracting’  
           /s<sub>1</sub>am<sub>2</sub>m<sub>2</sub>aḥ<sub>3</sub>/, ‘to make attractive’                      /s<sub>1</sub>am<sub>2</sub>iḥ<sub>3</sub>/, ‘handsome’  
           /w<sub>1</sub>as<sub>2</sub>s<sub>2</sub>ax<sub>3</sub>/, ‘to make a mess’                            /w<sub>1</sub>as<sub>2</sub>ix<sub>3</sub>/, ‘dirty/ill-mannered’

c. /C<sub>1</sub>vC<sub>2</sub>C<sub>3</sub>/

- (274) /s<sub>1</sub>ar<sub>2</sub>r<sub>3</sub>/, ‘to hide something’                              /s<sub>1</sub>ir<sub>2</sub>r<sub>3</sub>/, ‘secret’  
           /ḥ<sub>1</sub>ar<sub>2</sub>r<sub>2</sub>ar<sub>3</sub>/, ‘to free somebody’                        /ḥ<sub>1</sub>ur<sub>2</sub>r<sub>3</sub>/, ‘free’  
           /ǎ<sub>1</sub>a<sup>1</sup>ǎ<sub>2</sub>ab<sub>3</sub>/, ‘to attract’                                        /ǎ<sub>1</sub>aǎ<sub>2</sub>b<sub>3</sub>/, ‘attracting’

d. /C<sub>1</sub>iC<sub>2</sub>C<sub>3</sub>a:C<sub>4</sub>/

In (d), the adjective morpheme is /a:/ and the active morphological site is after C<sub>3</sub>. However, it is not clear whether the function of the suffixed consonant /n/ has a morphological task associated with the adjective or if this suffix is supplied by the phonology in order to protect the length of the final vowel, which is the adjective morpheme, from being shortened. Deriving the BP of these singular adjectives involves the deletion of /n/ and keeping the adjectival marker at the rightmost periphery of the derived BP adjectives. Thus, it can be assumed that the phonology to supply this consonant is not clear since the length of the final long vowel is preserved in the BP. There is a morpho-semantic function adopted by many CA grammarians (cited in Samirrai, 2007). This function of /n/, when it follows the adjectival morpheme /a:/, is to denote a huge quantity of activity or action in a limited time:

(275)	/ʕ <sub>1</sub> r <sub>2</sub> iɣ <sub>3</sub> /, ‘to become sweaty’	/ʕ <sub>1</sub> i r <sub>2</sub> ɣ <sub>3</sub> ɑ:n <sub>4</sub> /, ‘sweaty’
	/s <sub>1</sub> k <sub>2</sub> i r <sub>3</sub> /, ‘to be drunk’	/s <sub>1</sub> i k <sub>2</sub> r <sub>3</sub> ɑ:n <sub>4</sub> /, ‘drunk’
	/z <sub>1</sub> ʔ <sub>2</sub> i l <sub>3</sub> /, ‘to be angry’	/z <sub>1</sub> i ʔ <sub>2</sub> l <sub>3</sub> ɑ:n <sub>4</sub> /, ‘angry’

Thus, one cannot say /s<sub>1</sub>i k<sub>2</sub>r<sub>3</sub>ɑ:n<sub>4</sub>/, ‘drunk’, for example, unless the object being described is totally drunk and not in control of himself/herself any more. Similarly, /z<sub>1</sub>i ʔ<sub>2</sub>l<sub>3</sub>ɑ:n<sub>4</sub>/, ‘angry’, is said to denote the object when it is fully possessed with anger. The difference between the two adjectives /C<sub>1</sub>iC<sub>2</sub>C<sub>3</sub>a:n<sub>4</sub>/ and /C<sub>1</sub>aC<sub>2</sub>i:C<sub>3</sub>/, as far as the time reference is concerned, is that /C<sub>1</sub>iC<sub>2</sub>C<sub>3</sub>a:n<sub>4</sub>/ refers to a limited time period while /C<sub>1</sub>aC<sub>2</sub>i:C<sub>3</sub> / refers to an unlimited period (Samirrai, 2007, 81). Because the suffix /n/ denotes quantity, it is plausible for it to be deleted in the derivation of BP since quantity is designated by the BP morpheme and there is no need to double mark the quantity. This function of /n/ is not yet clear since there is a BP form which exhibits this consonant in the final position, for example:

(276)	/ħ <sub>1</sub> u:t <sub>3</sub> /, ‘whale’	/ħ <sub>1</sub> i:t <sub>3</sub> ɑ:n <sub>4</sub> /
	/ʒ <sub>1</sub> ɑ:r <sub>3</sub> /, ‘neighbour’	/ʒ <sub>1</sub> i:r <sub>3</sub> ɑ:n <sub>4</sub> /

/f<sub>1</sub>a:r<sub>2</sub>iS<sub>3</sub>/, ‘knight’

/f<sub>1</sub>ur<sub>2</sub>S<sub>3</sub>a:n<sub>4</sub>/

/w<sub>1</sub>a:d<sub>2</sub>i:/, ‘valley’

/w<sub>1</sub>id<sub>2</sub>j<sub>3</sub>a:n<sub>4</sub>/

In all these BP forms, the BP morpheme is hosted after C<sub>3</sub>. However, the position of the BP morpheme occupies the same position as of the adjectival morpheme /a:/ in the preceding adjectives listed earlier. It can be noted that the consonant /n/ is suffixed in the adjective as well as in the BP lists. The positioning of the BP morpheme after C<sub>3</sub> suggests that all the words are actually adjectives. This is supported by the fact that both /f<sub>1</sub>a:r<sub>2</sub>iS<sub>3</sub>/ and /w<sub>1</sub>a:d<sub>2</sub>i:/ are active participle adjectives marked by the existence of the adjectival participle marker /a:/ after C<sub>1</sub>. Because these words are adjectives, this adjectival marker appears as /a:/ in the final position of the BP form. The existence of the /n/ also suggests that the meaning acquired by the BP form is similar to that of the adjective (see sections, 7.3.3 and 7.3.10, for further discussion).

e. /C<sub>1</sub>iC<sub>2</sub>C<sub>2</sub>a:C<sub>3</sub>/

In this adjective form, there are two morphological processes: the first is the doubling of the medial root consonant; the second is the infixation of the adjectival marker /a:/ in the position after the second part of the doubled medial root consonant. The function of doubling the medial consonant is to designate that the action is performed in an intensive and extensive manner, for example:

(277) /ʒ<sub>1</sub>a:l<sub>3</sub>/, ‘to wonder around’

/ʒ<sub>1</sub>iW<sub>2</sub>W<sub>2</sub>a:l<sub>3</sub>/, ‘explorer’

/f<sub>1</sub>aʔ<sub>2</sub>a:l<sub>3</sub>/, ‘to do’

/f<sub>1</sub>iʔ<sub>2</sub>ʔ<sub>2</sub>a:l<sub>3</sub>/, ‘effective’

The requirement of the morphological process to intensify the medial root segment forces the glide to surface with its consonantal features, as in /ʒ<sub>1</sub>iW<sub>2</sub>W<sub>2</sub>a:l<sub>3</sub>/. In such cases, the identical intensified segments are syllabified with respect to OCP, which requires the syllabification of these segments separately.



this should cause no problem so long as the syllable which contains the features of the glide is stressed. Thus, maximality must outrank the constraint which militates against open heavy syllables in the final position.

h. /ʔ<sub>4</sub>aC<sub>1</sub>C<sub>2</sub>aC<sub>3</sub>/

This form is associated with masculine adjectives which denote colours or physically defective characteristics of the body. Its equivalent feminine form is /C<sub>1</sub>aC<sub>2</sub>C<sub>3</sub>a : ʔ<sub>4</sub>/, for example:

(280)	/z <sub>1</sub> a r <sub>2</sub> r <sub>2</sub> a g <sub>3</sub> /, ‘to become blue’	/ʔ <sub>4</sub> a z <sub>1</sub> r <sub>2</sub> a g <sub>3</sub> /, ‘blue’
	/ħ <sub>1</sub> a m <sub>2</sub> m <sub>2</sub> a r <sub>3</sub> /, ‘to become red’	/ʔ <sub>4</sub> a ħ <sub>1</sub> m <sub>2</sub> a r <sub>3</sub> /, ‘red’
	/ʕ <sub>1</sub> a m <sub>2</sub> a :/, ‘to become blind’	/ʔ <sub>4</sub> a ʕ <sub>1</sub> m <sub>2</sub> a :/, ‘blind’
	/t <sup>ʕ</sup> <sub>1</sub> a r <sub>2</sub> a ʃ <sub>3</sub> /, ‘to become deaf’	/ʔ <sub>4</sub> a t <sup>ʕ</sup> <sub>1</sub> r <sub>2</sub> a ʃ <sub>3</sub> /, ‘deaf’

It is difficult to decide whether the glottal stop has a lexical or phonological function. If it has a lexical function in the examples given above, then it could be considered as an adjectival derivational morpheme. If it has a phonological function, then the surfacing of this glottal stop is epenthesized to break the initial cluster created by the morphological process. That is to say, the lexical vowel may be the second one and not the first.

## 6.2 Participles

Participle adjectives are not morphologically derived from their corresponding verbs. However, the relationship between the two is closely reflected in their meanings, which has led some grammarians to call them ‘verbal adjectives’ (Erwin, 1963, 219). However, as has already been claimed of this thesis, the phonological structure of the base form of the verb does not stand in complete correspondence with the phonological structure of the derived form. Also, the morphological structure of the base does not usually stand in correspondence with the morphological structure of the derived word. Thus, the derivation of adjectives is achieved by the activation of the morphological active sites which exist between the root consonants by the adjectival

morphemes, and the morphological derivational relations must always be evaluated as a relation between the underlying structure of the base, which is the root consonants plus any active morphological structure, and the derived word which is the underlying form of the base plus any morphological structure associated with the derivation of the derived word. In this sense, assuming an overt relationship between a specific verb form and the adjective form from which it is derived is often a misleading derivational attribution. Since infixational processes require the restructuring of the base form, it is often hard to see any complete correspondence between the base and its derived form. Consequently, we must be very careful in the use of the term ‘verbal adjectives’, although it cannot be denied that sometimes there is a relationship between the morphological structure of the verb and the corresponding morphological structure in the derived adjective form. This will be illustrated below in the analysis of the morphological derivational processes of such adjectives.

As far as meaning is concerned, the active participle describes the doer who carries out an action, while the passive participle describes the object acted upon, or it describes how the action affects this object. In Arabic, therefore, active participle adjectives denote and indicate objects which are engaged in an activity, process, or state (Ryding, 2005, 102). Voice, at times, distinguishes the active participle from the passive participle. In LA, however, there are many cases in which the active participle is over-generalized to express both participles. This leaves to the context the distinction between meanings of these participles. Participles are substantives; they can refer to a noun class or as adjective class. The derivations of participles from trilateral root consonants are given as follows.

## **6.2.1 Trilateral Adjectives**

### **6.2.1.1 Form I**

The main differences between active and passive patterns of Form I is the type of morphemes which identify the active morphological sites in each pattern. The Form I active participle is derived by infixing the morpheme /a :/ after C<sub>1</sub>. Its passive pattern is derived by two morphological processes: the infixing of the morpheme /u :/ after

the second root consonant  $C_2$ ; and the prefixing of the morpheme /m/ which precedes the first root consonant. Augmenting the morphemes in any morphological process is not random, but is rather achieved by identifying and activating the active morphological sites. That is to say, the difference between the active and the passive participles lies in the way they identify the active morphological sites and the type of morphemes processed in their morphological derivations. Form I participles have the structural patterns / $C_1a:C_2iC_3$ / for active and / $m_4aC_1C_2u:C_3$ / for passive, for example:

(281) Verb	Active Participle	Passive Participle
/k <sub>1</sub> at <sub>2</sub> ab <sub>3</sub> /, ‘to write’	/k <sub>1</sub> a:t <sub>2</sub> ib <sub>3</sub> /, ‘writer’	/m <sub>4</sub> ak <sub>1</sub> t <sub>2</sub> u:b <sub>3</sub> /, ‘written’
/ħ <sub>1</sub> ak <sub>2</sub> am <sub>3</sub> /, ‘to rule’	/ħ <sub>1</sub> a:k <sub>2</sub> im <sub>3</sub> /, ‘ruler’	/m <sub>4</sub> aħ <sub>1</sub> k <sub>2</sub> u:m <sub>3</sub> /, ‘ruled’
/g <sub>1</sub> at <sub>2</sub> al <sub>3</sub> /, ‘to kill’	/g <sub>1</sub> a:t <sub>2</sub> il <sub>3</sub> /, ‘killer’	/m <sub>4</sub> ag <sub>1</sub> t <sub>2</sub> u:l <sub>3</sub> /, ‘killed’

Interestingly, the morpheme /u:/ of the passive participle identifies the second root consonant  $C_2$  as the active morphological site, which means that in the derivational process the morpheme /u:/ is identified first before the prefix /m/. The position of the second root consonant is very important in many morphological processes in LA, such as the derivation of some forms of BP, some adjectives, and some verb forms. After the active morphological sites are identified by the specific morphemes, the phonology comes into play with the role of parsing the segments into syllables or feet. The instances given in the preceding examples are in their optimal outputs at the surface level. However, in their underlying forms, as we have been assuming for the derivation of non-concatenative morphology, only the string of root consonants plus the targeted morphological morphemes exist. In other words, only the morphological units exist and not the phonological units.

Let us first consider the underlying form of the active participle form /k<sub>1</sub>a:t<sub>2</sub>ib<sub>3</sub>/. Its underlying form consists of the string of the root consonants plus the morpheme /a:/ identified after the first root consonant  $C_1$ , which is  $\sqrt{ktb} + /a:/$ , yielding the structure  $\sqrt{ka:t}b$ . Since the morpheme with  $C_1$  creates an optimal well-formed open heavy syllable, the last two root consonants are left unparsed. Consequently, the phonology syllabifies these two consonants in another syllable by inserting an

epenthetic vowel /i/ which gives the optimal form /k<sub>1</sub>a:.t<sub>2</sub>ib<sub>3</sub>/. Similarly, the underlying structure for the passive form is  $\sqrt{ktu:b} + m-$ , which gives the structure  $\sqrt{mktu:b}$ . The last two consonants are syllabified by the morpheme /u:/ which occupies the nucleus position of the final created syllable. Since all segments must be syllabified at the surface level, the prefix and the first root consonant cannot be a part of the onset of the already well-formed syllable, since clusters are not usually allowed and they cannot be left unparsed syllabically. Thus, an epenthetic low vowel is inserted to augment the two segments in a new syllable which gives the final optimal form /m<sub>4</sub>ak<sub>1</sub>t<sub>2</sub>u:b<sub>3</sub>/. This suggested mode of derivation is also evident in the fact that in both participles the stress falls on the syllables which contain the long vowels, in which they form the heaviest syllable in each derived participle form. In other words, the long vowels identify the nucleus position in each derived form, and as a result any segment which is not identified as a part of a well-formed syllable has to be syllabified in a new syllable.

The requirement of the language to parse the underlying morphological structure into a well-formed prosodic structure at the surface is constrained by various syllabic and prosodic constraints. For example, as just pointed out, the active participle morpheme /a:/ is already positioned in a bimoraic syllable accepted by the language which requires syllables to be parsed moraically. This causes no problem in the syllabification of the first root consonant C<sub>1</sub>, but a problem is caused by the lack of parsing of C<sub>2</sub> and C<sub>3</sub>. There are two possibilities for parsing the last two root consonants: either as a string of complex coda to the preceding syllable; or to be parsed into a newly formed syllable. However, parsing them as a coda would lead to two violations of highly ranked constraints: one militating against consonant clusters and a other requiring syllables to be parsed moraically. Parsing them as a coda would create a trimoraic syllable in which the second root consonant is syllabified as a mora to an already formed heavy syllable, as can be seen from the follow candidate (b). The brackets are given to show the possible foot structure:



(282)

Input: [ká : tɓ]	*COMPLEX	FOOTBIN	DEP
a. → (k <sub>1</sub> a :). (t <sub>2</sub> i b <sub>3</sub> )		*	*
b. (k <sub>1</sub> a : t <sub>2</sub> b <sub>3</sub> )	*!	**	

The asterisks in the FOOTBIN grid represent the violations of foot binarity by the number of unfooted moras. Candidate (b) has two violations of the higher ranked constraints. This is caused by the coda cluster which contains a string of two consonants. At the same time, this cluster creates with the heavy nucleus a string of four moras which is never permitted by the binarity requirement of the language. Candidate (a), on the other hand, avoids the complex coda by syllabifying the last two root consonants in a new syllable by inserting a short vowel. Although it violates the constraint which militates against epenthesis, this violation is considered a violation of the low ranked constraint. This candidate satisfies the first higher ranked constraint fully and by comparison it violates the second higher ranked constraint minimally. Thus, the way candidate (a) syllabifies the segments satisfies the prosodic structure of the language and leads it to outrank candidate (b).

The derivation of the passive participle of the preceding active participle is different, since it requires the identification of two active morphological sites. The augmentation of the affixational morphemes is as follows. The prefix /m-/ identifies the external active site which precedes the first root consonant C<sub>1</sub>, while the infixational /u:/ identifies the internal active site positioned between C<sub>2</sub> and C<sub>3</sub>. This gives the underlying structure of the passive participle, which is /mktu : b/. Now, as a result of the morphological process, C<sub>2</sub> and C<sub>3</sub> plus the morpheme /u:/ create a heavy well-formed syllable. However, the prefix plus C<sub>1</sub> are not syllabified yet and both are given by the morphology as a string of consonants as shown in candidate (b) in the follow tableau:

(283)

Input: [m̂ktû : b]	*COMPLEX	DEP
a. (m <sub>4</sub> ak <sub>1</sub> ). (t <sub>2</sub> u : b <sub>3</sub> )		*
b. (m <sub>4</sub> k <sub>1</sub> t <sub>2</sub> u : b <sub>3</sub> )	*!	

Because such a complex onset is not permitted by the language, the phonology inserts a short vowel in such a way that the prefix and C<sub>1</sub> are syllabified together. Thus, candidate (a) is chosen as the possible optimal candidate.

If the final two root consonants are identical, the active and the passive participles have the structural forms /C<sub>1</sub>a:C<sub>2</sub>C<sub>3</sub>/ and /m<sub>4</sub>aC<sub>1</sub>C<sub>2</sub>u:C<sub>3</sub>/ respectively. Such structures are forced by the constraint OCP which militates against the adjoining of identical segments. In both forms of the participles, the second identical segments are considered extrametrical since they do not contribute to the foot weight, for example:

- (284) /r<sub>1</sub>αd<sub>2</sub>d<sub>3</sub>/, ‘to return’    /r<sub>1</sub>α:d<sub>2</sub>d<sub>3</sub>/, ‘having returned’    /m<sub>4</sub>a r<sub>1</sub>d<sub>2</sub>u:d<sub>3</sub>/, ‘returned’  
       /ħ<sub>1</sub>ab<sub>2</sub>b<sub>3</sub>/, ‘to love’        /ħ<sub>1</sub>a:b<sub>2</sub>b<sub>3</sub>/, ‘having loved’        /m<sub>4</sub>aħ<sub>1</sub>b<sub>2</sub>u:b<sub>3</sub>/, ‘loveable’

In the active participle form /r<sub>1</sub>α:d<sub>2</sub>d<sub>3</sub>/, for example, there is no need to syllabify the identical segments in an independent syllable. This is because in actual speech it is pronounced as one segment, and also this could be related to the sonority sequence since one of the motivations to break consonant clusters is to avoid a rising in sonority in such final positions. Thus, there is no motivation to insert a short vowel between the identical segments, since there is no violation of sonority.

On the other hand, the identical segments of the passive participle are split because of the activation of the morphological site of passiveness which occurs between them. Thus, the distance between the two segments is autosegmentally respected. The first segment takes the position of the onset, while the second takes the position of the extra syllabic position.

Participles derived from hollow verbs have the patterns of structural forms /C<sub>1</sub>a:j<sub>2</sub>iC<sub>3</sub>/ and /m<sub>4</sub>aC<sub>1</sub>j<sub>2</sub>u:C<sub>3</sub>/ respectively, for example:

- (285)  
       /z<sub>1</sub>a:d<sub>3</sub>/, ‘to increase’    /z<sub>1</sub>a:j<sub>2</sub>i d<sub>3</sub>/, ‘having increased’    /m<sub>4</sub>a z<sub>1</sub>j<sub>2</sub>u:d<sub>3</sub>/, ‘increased’  
       /z<sub>1</sub>α:r<sub>3</sub>/, ‘to visit’        /z<sub>1</sub>a:j<sub>2</sub>i r<sub>3</sub>/, ‘visitor’                /m<sub>4</sub>a z<sub>1</sub>j<sub>2</sub>u:r<sub>3</sub>/, ‘being visited’

The morphological process of the participles requires the medial glide to surface with its consonantal features for two different reasons. In the active participle, the glide surfaces with its default consonantal features as a radical root consonant without any phonological motivation to surface as vocalic. In this way, the glide plus the final consonant are in the position of a coda cluster. Since the active participle morpheme identifies  $C_1$  as the host,  $C_1$  with the active participle derivational morpheme together create a heavy syllable. The underlying structure for the active participle, after identifying the active morphological site, is  $\sqrt{Z_1 a : j_2 d_3}$ . To avoid the consonant cluster, an epenthetic vowel is inserted. The glide surfaces in the passive participle in order to fulfil the morphological requirement for  $C_2$  to host the passive participle morpheme. Thus, the underlying structure for the passive form is  $\sqrt{m_4 Z_1 j_2 u : d_3}$  with an onset cluster.

Interestingly, participles derived from defective verbs have the patterns  $/C_1 a : C_2 i/$  and  $/m_4 a C_1 C_2 i/$  respectively where the passive morpheme  $/u :/$  does not surface, for example:

(286)

$/k_1 a w_2 e :/$ , ‘to cauterize’    $/k_1 a : w_2 i/$ , ‘having cauterized’    $/m_4 a k_1 w_2 i/$ , ‘cauterized/ironed’

$/\Omega_1 a f_2 e :/$ , ‘to exempt’    $/\Omega_1 a : f_2 i/$ , ‘having exempted’    $/m_4 a \Omega_1 f_2 i/$ , ‘exempted’

Because of the instability of the glide in the final position, it is forced to surface only with its vocalic features and not with its consonantal features, and then consequently is subject to long-vowel shortening in the final position. Hence, these restrictions on the glide in the final position cause the deletion of the passive morpheme  $/u :/$  in favour of the glide being able to surface with its vocalic features. The motivation for this deletion is the fact that if the passive morpheme surfaced with the vocalic features of the glide, the final syllable would have a string of three vowels. Another reason could be related to the quality of the resulting string of vowels. These vowels consist of two back vowels (passive morpheme  $/u :/$ ) and one front vowel (the glide  $/j/$  which surfaces as  $/i/$ ), which gives the underlying structure form  $\sqrt{m_4 k_1 w_2 u : j_3/}$ . Then, after the glide surfaces as vocalic, it gives  $\sqrt{m_4 k_1 w_2 u : i/}$ . However, such a

combination is not possible in the language. Let us consider the states of the final glide in the derivation of the active participle /k<sub>1</sub>a : .w<sub>2</sub>i/. There are two possible realizations for the final glide: the first (candidate (c) below) is to surface as a consonant in which it creates a coda cluster; the second is to surface as vocalic. However, candidate (c) is ruled out by a constraint which militates against consonant clusters, and the second possible realization is constrained by the constraint militating against heavy open syllables in the final position as is the case with candidate (b). This length of the long vowel is in fact the combination of the epenthetic vowel /i/ plus the vocalic realization of the glide /j/. Since this glide is not in the position of a stressed syllable, it surfaces with its vocalic features in such a way that it obeys the constraint which militates against a heavy open syllable in the final position:

(287)

Input: [kâ : wj]	*COMPLEX	*V:] <sub>STEM</sub>	MAX
a. → /k <sub>1</sub> a : .w <sub>2</sub> i/			*
b. /k <sub>1</sub> a : .w <sub>2</sub> i : /		*!	
c. /k <sub>1</sub> a : w <sub>2</sub> j <sub>3</sub> /	*!		

In the derivation of the passive form of the preceding example, the appearance of the glide preceded by the active participle morpheme /u : / leads to complex phonological processes. The follow tableau shows four possible candidates. We can ignore the syllabification of the prefix since our main focus here is the realization of the final glide when it is augmented with the internal passive participle morpheme /u :/. It is obvious that candidate (d) shows some faithfulness to the underlying morphological process, but such surfacing of the consonantal features of the glide violates the constraint \*GLIDE]<sub>STEM</sub> which requires the glide to surface with its vocalic features. The realization of the vocalic features of the glide in candidate (c) creates a string of trimoraic moras. This superheavy nucleus is ruled out by the constraint which militates against trimoraic moras. However, there is another effect shown in candidate (b), which is the avoidance of the existence of non-homogeneous vowels within the same nucleus. In candidate (b), the markedness constraint \*[u+i] causes the deletion of the passive participle morpheme /u :/. In this case, the faithfulness constraint MAX which militates against the deletion of input segments, which including the

morphological morphemes, must be low ranked. Candidate (a) wins by shortening the final long vowel. Although the winning candidate (a) also deletes the participle morpheme, the source of the last vowel /i/ is difficult to tell, since it could either be the result of the glide surfacing as vocalic or as the result of deleting the glide altogether and replacing it with an epenthetic vowel in order to syllabify /w/:

(288)

Input: [m̂kwû : j]	*GLIDE] <sub>STEM</sub>	*TRIMORAIC	*[u+i]	*V:] <sub>STEM</sub>	MAX
a. → /m <sub>4</sub> ak <sub>1</sub> .w <sub>2</sub> i/					*
b. /m <sub>4</sub> ak <sub>1</sub> .w <sub>2</sub> i : /				*	*
c. /m <sub>4</sub> ak <sub>1</sub> .w <sub>2</sub> u : i/		*!	*		
d. /m <sub>4</sub> ak <sub>1</sub> .w <sub>2</sub> u : j/	*!	*	*		

### 6.2.1.2 Form II

The active participle of this form has the structure /m<sub>4</sub>(u)C<sub>1</sub>aC<sub>2</sub>C<sub>2</sub>iC<sub>3</sub>/ and its passive participle has the structure /m<sub>4</sub>(a)C<sub>1</sub>aC<sub>2</sub>C<sub>2</sub>aC<sub>3</sub>/. Both forms double the medial root consonants. There is an obvious phonological difference between the active and passive participle: the former has a raised short vowel realized as /i/ in the final syllable, while the latter has a low short vowel realized as /a/. Both vowels can be used to distinguish morpho-semantically between the two participles, for example:

(289)

/z<sub>1</sub>ar<sub>2</sub>r<sub>2</sub>a<sub>3</sub>/, 'to plant'    /m<sub>4</sub>z<sub>1</sub>ar<sub>2</sub>r<sub>2</sub>i<sub>3</sub>/, 'having grown'    /m<sub>4</sub>z<sub>1</sub>ar<sub>2</sub>r<sub>2</sub>a<sub>3</sub>/, 'grown'  
 /ʃ<sub>1</sub>ar<sub>2</sub>r<sub>2</sub>a<sub>3</sub>/, 'to open'    /m<sub>4</sub>ʃ<sub>1</sub>ar<sub>2</sub>r<sub>2</sub>i<sub>3</sub>/, 'having opened'    /m<sub>4</sub>ʃ<sub>1</sub>ar<sub>2</sub>r<sub>2</sub>a<sub>3</sub>/, 'opened'

As the verb forms are given for illustration, we are not assuming any complete correspondence relation between the verb and any of the participle forms. Though in some morphological derivational processes, as we have in many previous examples, there is strong evidence that the morphological processes of the input are carried over to the output derived form. For example, doubling the medial root consonant is a morpho-semantically distinctive process in LA, and the function of doubling is to

intensify the action expressed and/or to account for the multiplicity of the action. That is to say, this process is not restricted to some verb forms only but can also be found in nouns as well as adjective forms. However, for the sake of simplicity, we take such a morphological process as evidence of correspondence as long as it is available in the verb and carried over to the derived participle form. Thus, the underlying structure for the participle is the root consonants plus the morphological process of doubling the medial consonant, and the derivational morphological processes which are the participle morpheme prefix /mu-/ and the short vowels /i/ for the active and /a/ for the passive in the final syllables. Let us consider the active participle form represented in the tableau:

(290)

Input: [m̂ûzrîŋ]	OCP	*CV	*COMPLEX	MAX	DEP
a. → /ʔim <sub>4</sub> .z <sub>1</sub> ar <sub>2</sub> .r <sub>2</sub> iŋ <sub>3</sub> /				*	*
b. /m <sub>4</sub> z <sub>1</sub> ar <sub>2</sub> .r <sub>2</sub> iŋ <sub>3</sub> /			*!	*	
c. /m <sub>4</sub> u.z <sub>1</sub> ar <sub>2</sub> .r <sub>2</sub> iŋ <sub>3</sub> /		*!			

The OCP requires the syllabification of the double root consonants in different syllables; otherwise the identical segments create consonant clusters. The predictable syllabification process, then, is represented by candidate (c) with an epenthetic vowel for the medial syllable. But since the language has a tendency to reduce the number of light open syllables and to delete unstressed short vowels, the first back vowel associated with the prefix is subject to deletion. Deleting the vowel also causes another problem by creating a complex onset as in candidate (b). Hence, candidate (a) can only win by ranking the faithfulness constraints below the markedness constraints.

For participles derived from defective verbs, they have the patterns /m<sub>4</sub>(u)C<sub>1</sub>aC<sub>2</sub>C<sub>2</sub>i/ and /m<sub>4</sub>C<sub>1</sub>aC<sub>2</sub>C<sub>2</sub>a/ respectively, for example:

(291)

/ʔ <sub>1</sub> ab <sub>2</sub> b <sub>2</sub> a/, ‘to fill up’	/m <sub>4</sub> ʔ <sub>1</sub> ab <sub>2</sub> b <sub>2</sub> i/, ‘full up’	/m <sub>4</sub> ʔ <sub>1</sub> ab <sub>2</sub> b <sub>2</sub> a/, ‘filled up’
/ʔ <sub>1</sub> an <sub>2</sub> n <sub>2</sub> a/, ‘to sing’	/m <sub>4</sub> uʔ <sub>1</sub> an <sub>2</sub> n <sub>2</sub> i/, ‘singer’	/m <sub>4</sub> ʔ <sub>1</sub> an <sub>2</sub> n <sub>2</sub> a/, ‘being sung’

What is of interest here is the state of the final glide. In the passive form, the glide is deleted but the passive participle morpheme /a/ remains as the nucleus of the final syllable. The tendency to delete the glide suggests that the final vowel of the active form is the active participle morpheme /i/ and not the vocalic realization of the glide. The following tableau shows the derivation of the passive form. The markedness and prosodic constraints rule out all of the losing candidates (d), (c), and (b). Although candidates (a) and (b) delete the glide altogether, because of MAX constraint the competition between them is solved by ranking DEP lower than \*COMPLEX. Thus, candidate (a) wins because it fully satisfies the top ranked constraints and minimally violates the low ranked constraints:

(292)

Input: [m̂ûɣ̂b̂âj]	*GLIDE] <sub>STEM</sub>	*[a+i]	*CV	*COMPLEX	DEP	MAX
a. → /ɥim <sub>4</sub> .ɣ <sub>1</sub> ab <sub>2</sub> .b <sub>2</sub> a/					*	**
b. /m <sub>4</sub> ɣ <sub>1</sub> ab <sub>2</sub> .b <sub>2</sub> a/				*!		**
c. /m <sub>4</sub> u.ɣ <sub>1</sub> ab <sub>2</sub> .b <sub>2</sub> aɪ/		*!	*			
d. /m <sub>4</sub> u.ɣ <sub>1</sub> ab <sub>2</sub> .b <sub>2</sub> aɟ <sub>3</sub> /	*!		*			

### 6.2.1.3 Form III

Active and passive participles of this form have the forms /m<sub>4</sub>(u)C<sub>1</sub>a:C<sub>2</sub>iC<sub>3</sub>/ and /m<sub>4</sub>(u)C<sub>1</sub>a:C<sub>2</sub>aC<sub>3</sub>/ respectively, for example:

(293)

/ĥ<sub>1</sub>a:k<sub>2</sub>am<sub>3</sub>/, ‘to judge’    /m<sub>4</sub>ĥ<sub>1</sub>a:k<sub>2</sub>im<sub>3</sub>/, ‘having judged’    /m<sub>4</sub>ĥ<sub>1</sub>a:k<sub>2</sub>am<sub>3</sub>/, ‘judged’  
 /ĥ<sub>1</sub>a:r<sub>2</sub>ib<sub>3</sub>/, ‘to fight’    /m<sub>4</sub>uĥ<sub>1</sub>a:r<sub>2</sub>ib<sub>3</sub>/, ‘fighter’    /m<sub>4</sub>uĥ<sub>1</sub>a:r<sub>2</sub>ab<sub>3</sub>/, ‘illegal’

The medial syllable of each participle form is syllabified by default since the morphological process specified with C<sub>1</sub> is carried over from the corresponding verb forms. These syllables are well-structured, since C<sub>1</sub> and the Form III verb morpheme create independent heavy open syllables in each derived form. The prefix is also syllabified by default since it has a Cv structure. The final participle morphemes are

vowels which form with C<sub>2</sub> and C<sub>3</sub> their independent syllables. In other words, each morphological morpheme, whether transferred from the verb form or supplied by the derivational process of the participles, fill all the internal active derivational sites. Although these morphemes are supplied by the morphological derivational process, the surface structure of each derived form is well-structured by default without any further phonological modification to the resulting outputs.

Participles derived from defective verbs have the forms /m<sub>4</sub>C<sub>1</sub>a:C<sub>2</sub>i/ and /m<sub>4</sub>C<sub>1</sub>a:C<sub>2</sub>a/ respectively. The glide does not surface at all. And as far as the participle morphemes are concerned, the back vowel associated with the prefix is deleted since they form together a light unstressed syllable which is subject to lose its vowel, and the internal participle morphemes occupy the nuclei of the final open syllables which have lost their glide codas, for example:

(294)

/m<sub>1</sub>α:r<sub>2</sub>α/, ‘to imitate’    /m<sub>4</sub>m<sub>1</sub>a:r<sub>2</sub>i/, ‘having imitated’    /m<sub>4</sub>m<sub>1</sub>α:r<sub>2</sub>α/, ‘imitated’  
 /ʒ<sub>1</sub>α:r<sub>2</sub>α/, ‘to agree’    /m<sub>4</sub>ʒ<sub>1</sub>a:r<sub>2</sub>i/, ‘supportive’    /m<sub>4</sub>ʒ<sub>1</sub>α:r<sub>2</sub>α/, ‘being supported’

#### 6.2.1.4 Form IV

The active participle of this form has the form /m<sub>4</sub>uC<sub>1</sub>C<sub>2</sub>iC<sub>3</sub>/ and the passive participle has the pattern /m<sub>4</sub>uC<sub>1</sub>C<sub>2</sub>aC<sub>3</sub>/, for example:

(295)

/ħ<sub>1</sub>aS<sub>2</sub>aN<sub>3</sub>/, ‘to give’    /m<sub>4</sub>uħ<sub>1</sub>S<sub>2</sub>iN<sub>3</sub>/, ‘giver’    -  
 /h<sub>1</sub>aM<sub>2</sub>aL<sub>3</sub>/, ‘to disregard’    /m<sub>4</sub>uh<sub>1</sub>M<sub>2</sub>iL<sub>3</sub>/, ‘careless’    /m<sub>4</sub>uh<sub>1</sub>M<sub>2</sub>aL<sub>3</sub>/, ‘disregarded’

This is another good example where it is difficult to tell whether the forms are derived from their corresponding verbs. The idea of correspondence between the two corresponding forms is driven by the assumption that the source of the derivation is the Form IV verb /ʔaCCaC/. However, the Form I verb /CaCaC/ could be also the source of the derivation of these participles. The hypothesis of active morphological



sites gives a solid account of the derivation of such forms. By activating the active morphological sites, the derived participles only make reference to the root consonants. This means that the initial glottal stop associated with Form IV verb is itself the result of activating its external site. However, this external site is not identified in the derived participles, which raises the question of why the source of the derivation could not be the Form I verb, for instance. The surface structure of the participles suggests that the participle morphemes fill the active morphological sites within the root consonants without any reference to the verb form. Thus, the morphological derivational process identifies the external active sites and fills them with the prefix /mu/, and identifies the internal active site by /i/ and /a/ for the active and passive participles respectively.

Participles which are derived from hollow verbs have the following structure: the active participle has the pattern /m<sub>4</sub>uC<sub>1</sub>i:C<sub>3</sub>/; and the passive participle has the pattern /m<sub>4</sub>uC<sub>1</sub>a:C<sub>3</sub>/, for example:

(296)

/d<sub>1</sub>α:r<sub>3</sub>/, ‘to administer’    /m<sub>4</sub>ud<sub>1</sub>i:r<sub>3</sub>/, ‘headmaster’    /m<sub>4</sub>ud<sub>1</sub>α:r<sub>3</sub>/, ‘administrated’  
 /ħ<sub>1</sub>α:t<sup>ʔ</sup><sub>3</sub>/, ‘to surround’    /m<sub>4</sub>uħ<sub>1</sub>i:t<sup>ʔ</sup><sub>3</sub>/, ‘ocean’    /m<sub>4</sub>uħ<sub>1</sub>α:t<sup>ʔ</sup><sub>3</sub>/, ‘surrounded’

The length of the long vowels of the derived participles is the result of a morpho-phonological process. This length is the effect of the internal participle morpheme vowel and its preceding glide. In the active participle, the morpheme /i/ is adjoined to the glide /w/ which is in the position of C<sub>2</sub>. However, there is a problem in the surfacing of such a combination because it is combined from non-homogeneous features. Recall that the glide has the features to surface as either a consonant or a vowel. Whichever way the glide surfaces, it creates an unacceptable combination with the active participle morpheme /i/ whether it surfaces as /wi/ or /ui/. Since the morpheme is internal and not in any way subject to deletion, this morpheme colours the preceding glide with its features. Because it is not possible for the glide to surface with its consonantal features as in candidate (c) below, the only way for the glide to appear is with its vocalic features, as in candidate (b) which is also not acceptable. Therefore, the possible surfacing for such a combination,

since the active participle has the priority to surface, is by spreading the features of /i/ to fill the position of the glide:

(297)

Input: [m̂ûdwîr]	GLIDE=μ	*[u+i]	MAX {I}	IDENT
a. → /m <sub>4</sub> u.d <sub>1</sub> i:r <sub>3</sub> /				*
b. /m <sub>4</sub> u.d <sub>1</sub> uir <sub>3</sub> /		*!	*	
c. /m <sub>4</sub> ud <sub>1</sub> .wir <sub>3</sub> /	*!		*	

The winning candidate (a) suggests that the language favours the preservation of the participle morpheme at the price of losing the features of the glide. Similarly, the derivation of the passive participle follows the same argument, but with the difference of spreading the features of the morpheme vowel /a/:

(298)

Input: [m̂ûdwâr]	GLIDE=μ	*[u+a]	MAX {A}	IDENT
a. → /m <sub>4</sub> u.d <sub>1</sub> a:r <sub>3</sub> /				*
b. /m <sub>4</sub> u.d <sub>1</sub> uar <sub>3</sub> /		*!	*	
c. /m <sub>4</sub> ud <sub>1</sub> .war <sub>3</sub> /	*!		*	

As can be seen from the tableau above, the identity of the vocalic features of the glide does not surface, but rather the passive morpheme vowel colours the features of the glide. The argument could be that the length of the long vowel is the result of a compensatory lengthening process; in other words, losing the glide and compensating for it with an epenthetic vowel. However, there is no obvious phonological motivation to delete the glide and also there is no motivation to account for an epenthetic vowel. The surface structures of the two participles give credit to the spreading of the participle morpheme vowels to the preceding vocalic features of the glide.

For final doubled root consonants, the active participle has the form /C<sub>1</sub>a:C<sub>2</sub>C<sub>3</sub>/ and the passive participle has the form /m<sub>4</sub>aC<sub>1</sub>C<sub>2</sub>u:C<sub>3</sub>/, for example:

(299)

/ʒ<sub>1</sub>an<sub>2</sub>n<sub>3</sub>/, 'to be mad'                      /ʒ<sub>1</sub>a:n<sub>2</sub>n<sub>3</sub>/, 'jinni'                      /m<sub>4</sub>aʒ<sub>1</sub>n<sub>2</sub>u:n<sub>3</sub>/, 'being mad'

/h<sub>1</sub>a m<sub>2</sub> m<sub>3</sub>/, ‘to be concerned’    /h<sub>1</sub>a : m<sub>2</sub> m<sub>3</sub>/, ‘important’    /m<sub>4</sub>a h<sub>1</sub> m<sub>2</sub> u : m<sub>3</sub>/, ‘concerned’

In the active participle forms, the participle morpheme identifies the active root site after C<sub>1</sub>. The doubled segments occur in a superheavy syllable, but the last doubled segment does not contribute to the weight since the syllable is already trimoraic. Consequently, there is no violation of OCP. On the other hand, the passive morphemes /m/ and /u :/ identify the external and internal active morphological sites respectively. The doubled consonants are separated by the internal participle morpheme in such a way that the last one is identified as extrametrical because the syllable is already heavy.

### 6.2.1.5 Form V

These adjectives are derived from the Form V verb. The morphology of the Form V verb exhibits two morphological processes: the prefix /t/ and the doubling of the medial root consonant. The participles have the form /m<sub>5</sub> u t<sub>4</sub> C<sub>1</sub> a C<sub>2</sub> C<sub>2</sub> i C<sub>3</sub>/ for the active and /m<sub>5</sub> u t<sub>4</sub> C<sub>1</sub> a C<sub>2</sub> C<sub>2</sub> a C<sub>3</sub>/ for the passive, but the productive forms are expressed with the raising of the initial back vowel. It must be noted that, in CA, the forms are /m<sub>5</sub> u t<sub>4</sub> a C<sub>1</sub> a C<sub>2</sub> C<sub>2</sub> i C<sub>3</sub>/ and /m<sub>5</sub> u t<sub>4</sub> a C<sub>1</sub> a C<sub>2</sub> C<sub>2</sub> a C<sub>3</sub>/, where the initial two morphemes are syllabified in successive open light syllables. However, as is mentioned in many places, LA tends to reduce the number of consecutive light syllables to create a heavy closed syllable. The forms given above reflect the optimal structures for the syllabification of these output participles, as in the following examples:

- (300) /t<sub>4</sub> a h<sub>1</sub> a w<sub>2</sub> w<sub>2</sub> a l<sub>3</sub>/, ‘to remove’  
           /m<sub>5</sub> i t<sub>4</sub> h<sub>1</sub> a w<sub>2</sub> w<sub>2</sub> i l<sub>3</sub>/, ‘removable’    /m<sub>5</sub> i t<sub>4</sub> h<sub>1</sub> a w<sub>2</sub> w<sub>2</sub> a l<sub>3</sub>/, ‘being removed’
- /t<sub>4</sub> a h<sub>1</sub> a r<sub>2</sub> r<sub>2</sub> a k<sub>3</sub>/, ‘to move’  
           /m<sub>5</sub> i t<sub>4</sub> h<sub>1</sub> a r<sub>2</sub> r<sub>2</sub> i k<sub>3</sub>/, ‘removed’    /m<sub>5</sub> i t<sub>4</sub> h<sub>1</sub> a r<sub>2</sub> r<sub>2</sub> a k<sub>3</sub>/, ‘being removed’

One of the differences between CA and LA arises at the level of syllabification. In CA, there is a preference for syllabifying morphological morphemes in independent syllables in such a way that a morpheme cannot co-exist with another morpheme. In LA, however, this mode of the syllabification of morphemes is often challenged whenever there are successive light syllables. Due to the fact that in a multi-syllable word the light syllables are on the left where the prefixal morphemes are hosted, any resulting initial successive light syllables are reduced to a closed syllable where the infixational second vowel of the light syllable is deleted. The deletion of the second vowel could be related either to its nature, since it is inserted by the phonology and is not a stem vowel, or to the fact that the first vowel is a participle morpheme which cannot be deleted. The input form of the CA active participle [m<sub>5</sub>ut<sub>4</sub>aħ<sub>1</sub>αw<sub>2</sub>w<sub>2</sub>il<sub>3</sub>] is illustrated in the following tableau. It must be noted that all of the morphemes are syllabified independently in such a way that each morpheme consonant occupies either an onset or coda position and each vowel morpheme occupies a nucleus position. Also, the distribution of the doubled consonants is guaranteed by OCP, so we do not need to mention this constraint again in the tableau. Hence, we will restrict our constraints to account for the preference of the syllabification of the prefixal morphemes:

(301)

Input: [m <sub>5</sub> û t <sub>4</sub> aħ <sub>1</sub> αw <sub>2</sub> w <sub>2</sub> î l <sub>3</sub> ]	*CVCV	SEPARATE-MORPHEME	RAISE [u]	MAX
a. → /m <sub>5</sub> i t <sub>4</sub> .ħ <sub>1</sub> αw <sub>2</sub> .w <sub>2</sub> î l <sub>3</sub> /		*		*
b. /m <sub>5</sub> i.t <sub>4</sub> a.ħ <sub>1</sub> αw <sub>2</sub> .w <sub>2</sub> î l <sub>3</sub> /	*!			

The constraint RAISE [u] assures the preference in LA to fronting the initial back vowel. This is a productive phonological process where the language tends to front the vowel /u/ to /i/. As far as the difference between the two languages is concerned, ranking the constraint \*CVCV above SEPARATE-MORPHEME results in LA syllabification. Ranking them otherwise results in the CA preference of syllabification.

Form /m<sub>5</sub>i t<sub>4</sub>C<sub>1</sub>aC<sub>2</sub>C<sub>2</sub>i/ holds for the active participle derived from a verb that has a final glide which is deleted in the derivation of the participle form. The absence of the

corresponding passive form is related to the semantic meaning of the morpheme /t/, which refers here to the resultative state of the action, for example:

- (302) /t<sub>4</sub>aŷ<sub>1</sub>ɑd<sub>2</sub>d<sub>2</sub>a/, ‘to have lunch’      /m<sub>5</sub>it<sub>4</sub>ŷ<sub>1</sub>ɑd<sub>2</sub>d<sub>2</sub>i/, ‘having had lunch’  
       /t<sub>4</sub>aŷ<sub>3</sub>ag<sub>2</sub>g<sub>2</sub>a/, ‘to get promoted’      /m<sub>5</sub>it<sub>4</sub>r<sub>1</sub>ag<sub>2</sub>g<sub>2</sub>i/, ‘having had a promotion’

### 6.2.1.6 Form VI

This form has the structural form /m<sub>5</sub>ut<sub>4</sub>C<sub>1</sub>a:C<sub>2</sub>iC<sub>3</sub>/. The medial long vowel is carried over from the corresponding Form VI verb. The derivational process is similar to that of the Form V participle. Thus, the active constraints include the one that militates against successive light syllables and other which requires each morpheme to be syllabified independently. The meaning of the corresponding participles is carried over from the reciprocal meaning expressed in the Form VI verb which accounts for an action which involves two or more parties. However, the distinction between the two forms of the participle does not stand in correspondence with the morphemes of each participle. It sometimes requires an additional preposition with the passive participle form in order to clarify its meaning from the active participle, for example:

- (303) /t<sub>4</sub>ag<sub>1</sub>ɑ:b<sub>2</sub>il<sub>3</sub>/, ‘to confront’  
       /m<sub>5</sub>it<sub>4</sub>g<sub>1</sub>ɑ:b<sub>2</sub>il<sub>3</sub>/, ‘having faced/confronted’  
       /m<sub>5</sub>it<sub>4</sub>g<sub>1</sub>ɑ:b<sub>2</sub>al<sub>3</sub>/, ‘being faced/confronted’
- (304) /t<sub>4</sub>an<sub>1</sub>a:g<sub>2</sub>iʃ<sub>3</sub>/, ‘to have a discussion’  
       /m<sub>5</sub>it<sub>4</sub>n<sub>1</sub>a:g<sub>2</sub>iʃ<sub>3</sub>/, ‘having had a discussion’  
       /m<sub>5</sub>it<sub>4</sub>n<sub>1</sub>a:g<sub>2</sub>aʃ<sub>3</sub>/, ‘being discussed’

The derived active participle from the defective final root consonant has the structural form /m<sub>5</sub>it<sub>4</sub>C<sub>1</sub>a:C<sub>2</sub>i/, where the final glide does not surface. The internal passive morpheme /a/ appears in the final position of the participle stem, but the stem does not complete the meaning without a preposition, for example:

- (305) /t<sub>4</sub>aŋ<sub>1</sub>ɑ:d<sub>2</sub>a/, ‘to assault’  
 /m<sub>5</sub>i t<sub>4</sub>ŋ<sub>1</sub>ɑ:d<sub>2</sub>i/, ‘having assaulted’  
 /m<sub>5</sub>i t<sub>4</sub>ŋ<sub>1</sub>ɑ:d<sub>2</sub>a + ʔa l e : h/, ‘the victim of assault’

- (306) /t<sub>4</sub>aŋ<sub>1</sub>ɑ:t<sup>ʔ</sup><sub>2</sub>ɑ/, ‘to use drugs’  
 /m<sub>5</sub>i t<sub>4</sub>ŋ<sub>1</sub>ɑ:t<sup>ʔ</sup><sub>2</sub>i/, ‘having used drugs’  
 /m<sub>5</sub>i t<sub>4</sub>ŋ<sub>1</sub>ɑ:t<sup>ʔ</sup><sub>2</sub>a + b i : h/, ‘the tool used for drugs’

### 6.2.1.7 Form VII

This Form has the structural form /m<sub>5</sub>i n<sub>4</sub>C<sub>1</sub>aC<sub>2</sub>iC<sub>3</sub>/ and it carries a passive meaning (Harrama, 1993, 201). The morpheme /n/, which is associated with the intransitive Form VII verb, may express, for example, a reflexive, resultative or passive (Ryding, 2005, 555). This passiveness is carried over from the verb and expressed in the participle form by the morpheme /n/. Although the active participle is overgeneralized, the passive structure is similar to that given for the Form VI participle, in which the passiveness is accounted for with an additional preposition added to the passive stem form, for example:

- (307) /n<sub>4</sub>ŋ<sub>1</sub>a z<sub>2</sub>a l<sub>3</sub>/, ‘to be isolated’                      /m<sub>5</sub>i n<sub>4</sub>ŋ<sub>1</sub>a z<sub>2</sub>i l<sub>3</sub>/, ‘isolated’  
 /n<sub>4</sub>ʒ<sub>1</sub>a r<sub>2</sub>a f<sub>3</sub>/, ‘to be driven away’                      /m<sub>5</sub>i n<sub>4</sub>ʒ<sub>1</sub>a r<sub>2</sub>i f<sub>3</sub>/, ‘driven away’

The prefixal consonant morphemes /m/ and /n/ could each be said to have a /CV/ syllable type. In this case, the overall syllable structure of the participle form will have a consecutive string of light syllables. However, the output shows that the initial syllable is a closed syllable. This closed syllable is structured by the stress assignment; recall that in the absence of heavy syllables the stress falls on the initial syllable and also because the language tends to reduce the number of unstressed light syllables which reaches four in the participle form:

(308)

Input: [m <sub>5</sub> i n <sub>4</sub> a f <sub>1</sub> a z <sub>2</sub> i l <sub>3</sub> ]	STRESS	*CV	MAX
a. → /'m <sub>5</sub> i n <sub>4</sub> . f <sub>1</sub> a. z <sub>2</sub> i l <sub>3</sub> /		**	*
b. /'m <sub>5</sub> i. n <sub>4</sub> a. f <sub>1</sub> a. z <sub>2</sub> i l <sub>3</sub> /		****!	

Both possible candidates satisfy the stress constraint but assign the initial stress in different ways. Candidate (b) assigns the stress to the initial syllable because all the syllables have an equal light weight, while candidate (a) also assigns stress to the initial syllable because it is the heaviest. However, the constraint which requires the reduction of light syllables chooses candidate (a) as optimal because it has the least number of light syllables and also because the constraint MAX is lower ranked.

Active participles which are derived from doubled final root consonants have the form /m<sub>5</sub>i n<sub>4</sub> C<sub>1</sub> a C<sub>2</sub> C<sub>3</sub>/, for example:

- (309) /n<sub>4</sub>ʃ<sub>1</sub> a l<sub>2</sub> l<sub>2</sub>/, 'to become paralyzed'      /m<sub>5</sub>i n<sub>4</sub> ʃ<sub>1</sub> a l<sub>2</sub> l<sub>3</sub>/, 'paralyzed'  
/n<sub>4</sub>s<sub>1</sub> a m<sub>2</sub> m<sub>3</sub>/, 'to get poisoned'      /m<sub>5</sub>i n<sub>4</sub> s<sub>1</sub> a m<sub>2</sub> m<sub>3</sub>/, 'poisoned'

(310)

Input: [m <sub>5</sub> i n <sub>4</sub> a ʃ <sub>1</sub> a l <sub>2</sub> l <sub>3</sub> ]	STRESS	*CV	MAX
a. → /m <sub>5</sub> i n <sub>4</sub> . ' ʃ <sub>1</sub> a l <sub>2</sub> l <sub>3</sub> /			*
b. /m <sub>5</sub> i. n <sub>4</sub> a. ' ʃ <sub>1</sub> a l <sub>2</sub> l <sub>3</sub> /		**!	

The form structure /m<sub>5</sub>i n<sub>4</sub> C<sub>1</sub> a : C<sub>3</sub>/ accounts for the active participle which has a hollow root consonant in this form. The glide neither surfaces in the verb form nor in the participle form, for example:

- (311) /n<sub>4</sub>ʃ<sub>1</sub> a : l<sub>3</sub>/, 'to be removed'      /m<sub>5</sub>i n<sub>4</sub> ʃ<sub>1</sub> a : l<sub>3</sub>/, 'having been removed'  
/n<sub>4</sub>h<sub>1</sub> a : r<sub>3</sub>/, 'to collapse'      /m<sub>5</sub>i n<sub>4</sub> h<sub>1</sub> a : r<sub>3</sub>/, 'collapsed'

The deletion of the glide in the two derived words is due to the fact that it is collapsed with the following vowel to create a bimoraic nucleus which surfaces as a long vowel /a:/. In fact, the glide is underlyingly represented as /j/ in the two corresponding forms. In order to understand the derivational morphological structure of the

participle, we need first look at the surface structure of the glide in the verb form. The morphological process of the Form VII verb is at the underlying level represented as  $[\sqrt{\int}j\text{L}, +/n-]$ , which yields the surface structure  $/n_4.\int_1a.j_2a\text{L}_3/$  in such a way that the prefixal morpheme is syllabified independently, and the root consonants are syllabified in a way which avoids any consonant clusters. The surface structure, although avoiding consonant clusters, positions the glide between two short vowels. In such a situation, the glide is deleted (Brame, 1970, 239). Consider the following tableau:

(312)

Input: $[\hat{n}\hat{\int}ajal]$	SEPARATE- MORPHEME	*v-G-v	MAX
a. $\rightarrow /n_4.\int_1a:l_3/$			*
b. $/n_4.\int_1a.j_2a\text{L}_3/$		*!	

The importance of the constraint SEPARATE- MORPHEME is to guarantee that the syllabification of the prefixal morpheme is in an independent syllable, which is satisfied by the two possible candidates. The actual competition is between the markedness constraint \*v-G-v which militates against the existence of a glide between two short vowels, and the faithfulness constraint which requires the preservation of the input root segments. Because the markedness constraint outranks the faithfulness constraint, candidate (a) is chosen as optimal. In a similar way, the derivation of the participle exhibits the loss of the glide:

(313)

Input: $[\hat{m}\hat{n}\hat{\int}ajal]$	*v-G-v	*CV	SEPARATE- MORPHEME	MAX
a. $\rightarrow /m_5in_4.\int_1a:l_3/$			*	*
b. $/m_5i.n_4a.\int_1a:l_3/$		*!		*
c. $/m_5in_4.\int_1aj_2a\text{L}_3/$	*!		*	

For active participles of defective verbs of this Form, the pattern is  $/m_5in_4C_1aC_2i/$ , for example:

- (314)  $/n_4\int_1at^{\text{?}}_2i/$ , ‘being given’                       $/m_5in_4\int_1at^{\text{?}}_2i/$ , ‘having been given’  
 $/n_4\int_1ar_2i/$ , ‘being bought’                               $/m_5in_4\int_1ar_2i/$ , ‘having been bought’



### 6.2.1.8 Form VIII

The patterns for active and passive participles of this Form are /m<sub>5</sub>uC<sub>1</sub>t<sub>4</sub>aC<sub>2</sub>iC<sub>3</sub>/ and /m<sub>5</sub>uC<sub>1</sub>t<sub>4</sub>aC<sub>2</sub>aC<sub>3</sub>/ respectively. It seems that the active participle pattern is used for both participles. However, only educated people distinguish between the two patterns, for example:

(315) /ħ<sub>1</sub>t<sub>4</sub>ar<sub>2</sub>am<sub>3</sub>/, ‘to respect’  
 /m<sub>5</sub>uħ<sub>1</sub>t<sub>4</sub>ar<sub>2</sub>im<sub>3</sub>/, ‘having respected’      /m<sub>5</sub>uħ<sub>1</sub>t<sub>4</sub>ar<sub>2</sub>am<sub>3</sub>/, ‘respected’

(316) /ħ<sub>1</sub>t<sub>4</sub>aq<sub>2</sub>ar<sub>3</sub>/, ‘to humiliate’  
 /m<sub>5</sub>uħ<sub>1</sub>t<sub>4</sub>aq<sub>2</sub>ir<sub>3</sub>/, ‘having humiliated’      /m<sub>5</sub>uħ<sub>1</sub>t<sub>4</sub>aq<sub>2</sub>ar<sub>3</sub>/, ‘humiliated’

The morpheme /t/ which is carried over from the Form VIII verb refers to the reflexive and resultative state of the action in which this morpheme connects the relation between the action and the doer or the object that is being affected by the action. Because this participle form conveys a passive or resultative meaning, the active participle sometimes cannot be derived (Ryding, 2005, 571). In normal circumstances, there are two consonantal morphemes associated with each participle structure in this form: the prefix /m/ and the infix /t/. There are also two vocalic morphemes which mark each participle. If we consider the active participle form /m<sub>5</sub>uħ<sub>1</sub>t<sub>4</sub>ar<sub>2</sub>im<sub>3</sub>/, for example, its underlying structure is [√ħtrm, + /mu-/, /i/] which yields [√muħtrim]. As far as syllabification is concerned, the vocalic morphemes of the participle identify the first and the last syllables as /mu.ħt.rim/. The question, then, is how to syllabify /ħ/ and /t/. There is no way to syllabify them as light syllables because that would create a consecutive structure of three light syllables, which is not favoured by the language. In order to reduce the number of light syllables without creating any complex consonant clusters, the first unsyllabified segment /ħ/ is adjoined as a coda to the preceding syllable. Otherwise, creating a complex structure is inevitable. In the tableau below, candidates (d) and (c) violate the constraint which militates against complex margins and they are consequently ruled

out. The competition between (b) and (a) is settled by the candidate that has the minimal number of light syllables. That is the winning candidate (a):

(317)

Input: [m̂ûħ̄r̄im]	*COMPLEX	*CV
a. → /m <sub>5</sub> uħ <sub>1</sub> .t <sub>4</sub> a.r <sub>2</sub> im <sub>3</sub> /		*
b. /m <sub>5</sub> u.ħ <sub>1</sub> a.t <sub>4</sub> a.r <sub>2</sub> im <sub>3</sub> /		***
c. /m <sub>5</sub> uħ <sub>1</sub> t <sub>4</sub> .r <sub>2</sub> im <sub>3</sub> /	*!	
d. /m <sub>5</sub> uħ <sub>1</sub> .t <sub>4</sub> r <sub>2</sub> im <sub>3</sub> /	*!	

For participles derived from doubled final roots, the form is /m<sub>5</sub>uC<sub>1</sub>t<sub>4</sub>iC<sub>2</sub>C<sub>3</sub>/ for the active and /m<sub>5</sub>uC<sub>1</sub>t<sub>4</sub>aC<sub>2</sub>C<sub>3</sub>/ for the passive, for example:

(318) /ħ<sub>1</sub>t<sub>4</sub>a.l<sub>2</sub>l<sub>3</sub>/, ‘to occupy’  
 /m<sub>5</sub>uħ<sub>1</sub>t<sub>4</sub>i.l<sub>2</sub>l<sub>3</sub>/, ‘occupier’                      /m<sub>5</sub>uħ<sub>1</sub>t<sub>4</sub>a.l<sub>2</sub>l<sub>3</sub>/, ‘occupied’

(319) /h<sub>1</sub>t<sub>4</sub>a.z<sub>2</sub>z<sub>2</sub>/, ‘to shake’  
 /m<sub>5</sub>uh<sub>1</sub>t<sub>4</sub>i.z<sub>2</sub>z<sub>3</sub>/, ‘being shaken’                      /m<sub>5</sub>uh<sub>1</sub>t<sub>4</sub>a.z<sub>2</sub>z<sub>3</sub>/, ‘shaken’

Participles of this form which are derived from hollow verbs have only the passive participle form /m<sub>5</sub>uC<sub>1</sub>t<sub>4</sub>a:C<sub>3</sub>/, for example:

(320) /ʔ<sub>1</sub>t<sub>4</sub>a:z<sub>3</sub>/, ‘to need’                      /m<sub>5</sub>uʔ<sub>1</sub>t<sub>4</sub>a:z<sub>3</sub>/, ‘desperate’  
 /x<sub>1</sub>t<sub>4</sub>a:r<sub>3</sub>/, ‘to choose’                      /m<sub>5</sub>ux<sub>1</sub>t<sub>4</sub>a:r<sub>3</sub>/, ‘chosen’

(321)

Input: [m̂ûx̄t̄ajar]	ONSET	*v-G-v	*CV	MAX
a. → /m <sub>5</sub> ux <sub>1</sub> .t <sub>4</sub> a:r <sub>3</sub> /				*
b. /m <sub>5</sub> u.x <sub>1</sub> a.t <sub>4</sub> a.iar <sub>3</sub> /	*!		***	
c. /m <sub>5</sub> u.x <sub>1</sub> a.t <sub>4</sub> a.j <sub>2</sub> ar <sub>3</sub> /		*!	***	

Participles of this form derived from defective verbs have the structural forms /m<sub>5</sub>iC<sub>1</sub>t<sub>4</sub>aC<sub>2</sub>i/ and /m<sub>5</sub>iC<sub>1</sub>t<sub>4</sub>aC<sub>2</sub>a/ respectively, for example:

- (322) /m<sub>1</sub>t<sub>4</sub>aħ<sub>2</sub>i/, ‘to be erased’  
 /m<sub>5</sub>um<sub>1</sub>t<sub>4</sub>aħ<sub>2</sub>i/, ‘having erased’      /m<sub>5</sub>um<sub>1</sub>t<sub>4</sub>aħ<sub>2</sub>a/, ‘erased’  
 /k<sub>1</sub>t<sub>4</sub>aw<sub>2</sub>e/, ‘to be cauterized’  
 /m<sub>5</sub>uk<sub>1</sub>t<sub>4</sub>aw<sub>2</sub>i/, ‘having cauterized’      /m<sub>5</sub>uk<sub>1</sub>t<sub>4</sub>aw<sub>2</sub>α/, ‘cauterized’

### 6.2.1.9 Form IX

This form is usually associated with adjectives which denote colours or defects in physical characteristics. The structural forms of both participles of this form have the same structure, which is /muC<sub>1</sub>C<sub>2</sub>aC<sub>3</sub>C<sub>3</sub>/ with a doubling of the final root consonant. The passive structure is very rare since the verb from which it is derived is intransitive (Ryding, 2005, 581). In LA, however, it is hard to tell whether the participle is actually derived from Form IX, Form II, or even Form I. This is because the participle derived from Form IX and/or Form II does exist, where as the Form II participle may be said to be a variant of Form IX, for example:

- (323) /ʔ<sub>4</sub>iS<sub>1</sub>w<sub>2</sub>ad<sub>3</sub>d<sub>3</sub>/, ‘to become black’      /m<sub>5</sub>uS<sub>1</sub>w<sub>2</sub>ad<sub>3</sub>d<sub>3</sub>/, ‘being black’  
 /ʔ<sub>4</sub>i b<sub>1</sub>j<sub>2</sub>ad<sup>ʔ</sup><sub>3</sub>d<sup>ʔ</sup><sub>3</sub>/, ‘to become white’      /m<sub>5</sub>ub<sub>1</sub>j<sub>2</sub>ad<sup>ʔ</sup><sub>3</sub>d<sup>ʔ</sup><sub>3</sub>/, ‘being white’

### 6.2.1.10 Form X

This participle Form has the structural forms /m<sub>6</sub>uS<sub>5</sub>t<sub>4</sub>aC<sub>1</sub>C<sub>2</sub>iC<sub>3</sub>/ and /m<sub>6</sub>uS<sub>5</sub>t<sub>4</sub>aC<sub>1</sub>C<sub>2</sub>aC<sub>3</sub>/ for active and passive participles respectively. The meaning denoted by these participle forms may be reflexive, estimative, or requestative (Ryding, 2005, 584; Wright, 2005, Vol. I, 44), for example:

- (324) /S<sub>5</sub>t<sub>4</sub>aʔ<sub>1</sub>m<sub>2</sub>al<sub>3</sub>/, ‘to use’  
 /m<sub>6</sub>uS<sub>5</sub>t<sub>4</sub>aʔ<sub>1</sub>m<sub>2</sub>il<sub>3</sub>/, ‘having used’      /m<sub>6</sub>uS<sub>5</sub>t<sub>4</sub>aʔ<sub>1</sub>m<sub>2</sub>al<sub>3</sub>/, ‘being used’  
 /S<sub>5</sub>t<sub>4</sub>aʔ<sub>1</sub>b<sub>2</sub>ad<sub>3</sub>/, ‘to slave’

/m<sub>6</sub>uS<sub>5</sub>t<sub>4</sub>aʔ<sub>1</sub>b<sub>2</sub>i d<sub>3</sub>/, ‘having slaved’ /m<sub>6</sub>uS<sub>5</sub>t<sub>4</sub>aʔ<sub>1</sub>b<sub>2</sub>a d<sub>3</sub>/, ‘being enslaved’

There are two consonantal morphemes inherited from the Form X trilateral verb. These are /s/ and /t/. On the other hand, the derivation of the participles supplies one consonantal morpheme which is /m/ and two morpheme vowels for each participle form. This makes a total of three morpheme consonants and two morpheme vowels for each participle form. All the consonant morphemes are considered prefixes in relation to the root consonants. The order of these morphemes is as follows: /t/ is associated with the Form VI trilateral verb and refers to a reflexive signification; and /s/ is associated with the Form X trilateral verb and refers to factitive, futuristic, possession, and declarative senses (Wright, 2005, Vol. I, 44-45). Hence, the underlying structure prior to the formation of the participle forms of /m<sub>6</sub>uS<sub>5</sub>t<sub>4</sub>aʔ<sub>1</sub>m<sub>2</sub>i l<sub>3</sub>/, for instance, is represented as √stʔml. In the formation of the active participle, its morphemes are spreaded in such a way that the first and last syllables resulting from the morphological process are phonologically acceptable. The underlying structure of the active participle is thus √mustʔmil. The leftmost and rightmost syllables seem to be phonologically acceptable. However, the underlying structure consists of three consecutive consonants which need to be syllabically parsed. There is no way to syllabify them in light syllable structures since this would create a string of light syllables in a language which tends to reduce the number of such syllables. Also it seems that the language has some restrictions on the number of permitted syllables. Consider the following tableau which represents the phonological constraints that shape the optimal candidate:

(325)

Input: [m̂ûŝt̂ʔ̂m̂il̂]	*COMPLEX	*4 SYLLABLES	*CV	DEP
a. → /m <sub>6</sub> uS <sub>5</sub> .t <sub>4</sub> aʔ <sub>1</sub> .m <sub>2</sub> i l <sub>3</sub> /				*
b. /m <sub>6</sub> u.S <sub>5</sub> a.t <sub>4</sub> a.ʔ <sub>1</sub> a.m <sub>2</sub> i l <sub>3</sub> /		*!	*****	***
c. /m <sub>6</sub> uS <sub>5</sub> t <sub>4</sub> .ʔ <sub>1</sub> m <sub>2</sub> i l <sub>3</sub> /	*!			

Candidate (c) is the candidate faithful to the underlying structure of the input. But since it surfaces with complex margins, it is ruled out by the constraint that militates against margin complexity. This constraint is always at work after any morphological

process. Candidate (b) assumes that each consonant has at the underlying level a light syllable structure; however, it violates two constraints which cause structural preferences in syllabification. This candidate exceeds the maximum number of permitted syllables and at the same time has five consecutive light syllables. The optimal candidate (a) shows preference for the syllabification of the language in which the underlying form is syllabified by minimally violating the faithfulness constraint DEP, which requires the output to be as faithful as possible to the underlying form. Thus, the constraints \*4 SYLLABLES and \*CV must be treated as joint constraints because together they shape the syllabification preference of the output. In other words, the phonological constraints drive the output to form as many heavy syllables as possible. The asterisks show the number of violations, and candidate (a) has the least violations of the DEP constraint.

Participles derived from doubled verbs have the pattern /m<sub>6</sub>uS<sub>5</sub>t<sub>4</sub>aC<sub>1</sub>iC<sub>2</sub>C<sub>3</sub>/ for active participles and the pattern /m<sub>6</sub>uS<sub>5</sub>t<sub>4</sub>aC<sub>1</sub>aC<sub>2</sub>C<sub>3</sub>/ for passive participle, for example:

- (326)      /s<sub>5</sub>t<sub>4</sub>aħ<sub>1</sub>il<sub>2</sub>l<sub>3</sub>/, ‘to allow’  
                  /m<sub>6</sub>uS<sub>5</sub>t<sub>4</sub>aħ<sub>1</sub>il<sub>2</sub>l<sub>3</sub>/, ‘having allowed’      /m<sub>6</sub>uS<sub>5</sub>t<sub>4</sub>aħ<sub>1</sub>al<sub>2</sub>l<sub>3</sub>/, ‘being allowed’  
                  /s<sub>5</sub>t<sub>4</sub>aγ<sub>1</sub>al<sub>2</sub>l<sub>3</sub>/, ‘to use’  
                  /m<sub>6</sub>uS<sub>5</sub>t<sub>4</sub>aγ<sub>1</sub>il<sub>2</sub>l<sub>3</sub>/, ‘having used’      /m<sub>6</sub>uS<sub>5</sub>t<sub>4</sub>aγ<sub>1</sub>al<sub>2</sub>l<sub>3</sub>/, ‘being used’

Participles derived from hollow verbs have the form /m<sub>6</sub>uS<sub>5</sub>t<sub>4</sub>aC<sub>1</sub>i : C<sub>3</sub>/ for the active participle and /m<sub>6</sub>uS<sub>5</sub>t<sub>4</sub>aC<sub>1</sub>a : C<sub>3</sub>/ for the passive participle, for example:

- (327)      /s<sub>5</sub>t<sub>4</sub>aʒ<sub>1</sub>α : r<sub>3</sub>/, ‘to seek protection’  
                  /m<sub>6</sub>uS<sub>5</sub>t<sub>4</sub>aʒ<sub>1</sub>i : r<sub>3</sub>/, ‘having protected’      /m<sub>6</sub>uS<sub>5</sub>t<sub>4</sub>aʒ<sub>1</sub>α : r<sub>3</sub>/, ‘being protected’  
                  /s<sub>5</sub>t<sub>4</sub>aʔ<sub>1</sub>α : r<sub>3</sub>/, ‘to borrow’  
                  /m<sub>6</sub>uS<sub>5</sub>t<sub>4</sub>aʔ<sub>1</sub>i : r<sub>3</sub>/, ‘borrower’      /m<sub>6</sub>uS<sub>5</sub>t<sub>4</sub>aʔ<sub>1</sub>α : r<sub>3</sub>/, ‘borrowed/false’

Participles derived from defective verbs of Form X have the following forms: for the active participle /m<sub>6</sub>uS<sub>5</sub>t<sub>4</sub>aC<sub>1</sub>C<sub>2</sub>i/ and for the passive participle /m<sub>6</sub>uS<sub>5</sub>t<sub>4</sub>aC<sub>1</sub>C<sub>2</sub>a/ as follows:

- (328) /s<sub>5</sub>t<sub>4</sub>ah<sub>1</sub>d<sub>2</sub>a/, ‘to calm down’  
 /m<sub>6</sub>uS<sub>5</sub>t<sub>4</sub>ah<sub>1</sub>d<sub>2</sub>i/, ‘having calm down’    /m<sub>6</sub>uS<sub>5</sub>t<sub>4</sub>ah<sub>1</sub>d<sub>2</sub>a/, ‘being calmed down’  
 /s<sub>5</sub>t<sub>4</sub>ay<sub>1</sub>n<sub>2</sub>a/, ‘to get enough’  
 /m<sub>6</sub>uS<sub>5</sub>t<sub>4</sub>ay<sub>1</sub>n<sub>2</sub>i/, ‘having had enough’    /m<sub>6</sub>uS<sub>5</sub>t<sub>4</sub>ay<sub>1</sub>n<sub>2</sub>a/, ‘being ruled out’

## 6.2.2 Quadrilateral Adjectives

Participles of this type are derived from their corresponding quadrilateral root consonants. They have the structural forms /m<sub>5</sub>uC<sub>1</sub>aC<sub>2</sub>C<sub>3</sub>iC<sub>4</sub>/ and /m<sub>5</sub>uC<sub>1</sub>aC<sub>2</sub>C<sub>3</sub>aC<sub>4</sub>/ respectively, for example:

- (329) /t<sub>1</sub>ar<sub>2</sub>ʒ<sub>3</sub>am<sub>4</sub>/, ‘to translate’  
 /m<sub>5</sub>ut<sub>1</sub>ar<sub>2</sub>ʒ<sub>3</sub>im<sub>4</sub>/, ‘translator’    /m<sub>5</sub>ut<sub>1</sub>ar<sub>2</sub>ʒ<sub>3</sub>am<sub>4</sub>/, ‘translated’  
 /h<sub>1</sub>an<sub>2</sub>d<sub>3</sub>as<sub>4</sub>/, ‘to organise’  
 /m<sub>5</sub>uh<sub>1</sub>an<sub>2</sub>d<sub>3</sub>is<sub>4</sub>/, ‘engineer’    /m<sub>5</sub>uh<sub>1</sub>an<sub>2</sub>d<sub>3</sub>as<sub>4</sub>/, ‘well-planned’

(330)

Input: [m̂ûtrʒîm]	*COMPLEX	*CV	DEP
a. → /m <sub>5</sub> u.t <sub>1</sub> ar <sub>2</sub> .ʒ <sub>3</sub> im <sub>4</sub> /		*	*
b. /m <sub>5</sub> u.t <sub>1</sub> a.r <sub>2</sub> a.ʒ <sub>3</sub> im <sub>4</sub> /		***	**
c. /m <sub>5</sub> ut <sub>1</sub> r <sub>2</sub> .ʒ <sub>3</sub> im <sub>4</sub> /	*!		

Participles derived from quadrilateral verbs they have the following forms /m<sub>6</sub>it<sub>5</sub>C<sub>1</sub>aC<sub>2</sub>C<sub>3</sub>iC<sub>4</sub>/ and /m<sub>6</sub>it<sub>5</sub>C<sub>1</sub>aC<sub>2</sub>C<sub>3</sub>aC<sub>4</sub>/ respectively, for example:

- (331) /t<sub>5</sub>ay<sub>1</sub>at<sup>ʔ</sup><sub>2</sub>r<sub>3</sub>as<sub>4</sub>/, ‘to be snoopy’

/m<sub>6</sub>i t<sub>5</sub>ʔ<sub>1</sub>ɑ t<sup>ʔ</sup><sub>2</sub>r<sub>3</sub>i s<sup>ʔ</sup><sub>4</sub>/, ‘snoopy’

-

/t<sub>5</sub>aʔ<sub>1</sub>a s<sub>2</sub>k<sub>3</sub>a r<sub>4</sub>/, ‘to seek shelter’

/m<sub>6</sub>i t<sub>5</sub>ʔ<sub>1</sub>a s<sub>2</sub>k<sub>3</sub>i r<sub>4</sub>/, ‘protected’    /m<sub>6</sub>i t<sub>5</sub>ʔ<sub>1</sub>a s<sub>2</sub>k<sub>3</sub>a r<sub>4</sub>/, ‘being camped’

## 6.3 Inflection

Adjectives are similar to nouns in that they are inflected for gender, number and definiteness. Most feminine adjectives are derived from their corresponding masculine forms by the addition of the feminine morpheme suffix /-t/ which surfaces as a short vowel in a pause.

### 6.3.1 Gender

The augmentation of the feminine suffix to the masculine stem adjective requires some phonological adjustments as a consequence of augmenting the consonant suffix to the stem. The constraint \*COMPLEX militates against the cluster created by the suffix. Thus, in order to syllabify the suffix, an epenthetic vowel is needed to form a new syllable, for example:

(332)	Masculine	Feminine
	/kabi:r/, ‘big’	/kabi:r-at/
	/mangu:l/, ‘transferred’	/mangu:l-at/
	/t <sup>ʔ</sup> ɑ:lib/, ‘student’	/t <sup>ʔ</sup> ɑ:lib-at/
	/ʔaswad/, ‘black’	/so:d-at/
	/ʔaʔma:/, ‘blind’	/ʔamj-at/
	/sa:hi/, ‘absent-minded’	/sa:hj-at/
	/sirta:wi/, ‘From Sirt’	/sirta:wij-at/
	/li:bi/, ‘Libyan’	/li:bij-at/

### 6.3.2 Number

Singular and plural are the most distinguishable number categories in LA. Adjectives that modify dual nouns generally do not inflect for duality in LA, but rather take the plural form, for example:

- (333)        /sija:rtɛ:n ʒdid/, ‘two cars new’, ‘two new cars’  
               /zo:z krasɪ: ħumur/, ‘two chairs red’, ‘two red chairs’

Unless there is a requirement for emphasis, the modifier or the modifying word does not agree in number with the object being described. In /sija:rtɛ:n ʒdid/ the BP adjective form /ʒdid/ does not agree with the dual noun /sija:rtɛ:n/. The tendency here is to emphasize only the number of cars. The second example has the dual modifier /zo:z/ which designates the dual quantity. Nevertheless, neither the noun nor the adjective agree with the modifier since both words are BP structures.

There are two types of plurals for adjectives: SP and BP. SP adjectives consist of MSP and FSP. Adjectives that qualify for BP are discussed in the next chapter in details. For now, however, a few questions are raised regarding the surface structure of some adjectives that qualify for SP, and the possible candidates are explored.

#### 6.3.2.1 Sound Plural

Here, ‘sound plural’ is assumed to mean that the plural refers to the regularity of the derivation of the plural where no phonological processes affect the singular stem. However, this regularity of SP is questionable and it will be shown that the singular stem is subject to some phonological processing during the derivation of the plural. The morphological process for this type of plural is as follows: sound masculine plurals take the suffix /-i : n/; while sound feminine plurals take the suffix /-a : t/, for example:

- |       |                      |                  |
|-------|----------------------|------------------|
| (334) | Masculine Singular   | Masculine Plural |
|       | /maʒhu:l/, ‘unknown’ | /maʒhu:l-i : n/  |



/sahrɑ:n/, ‘awake at night’	/sahrɑ:n-i:n/
Feminine Singular	Feminine Plural
/ʒami:l-at/, ‘beautiful’	/ʒami:l-a:t/
/sirta:wijj-at/, ‘from Sirt’	/sirta:wijj-a:t/

Although the term sound/regular refers to the absence of phonological changes to the stem word, in many cases there does seem to be a phonological change to the stem when attaching the plural suffix, for example:

(335)	/ʔa:d <u>i</u> :/, ‘normal’	/ʔa:di <u>j</u> -i:n/
	/ha:ʒ <u>i</u> f/, ‘irresponsible’	/ha:ʒf-i:n/
	/mkass <u>a</u> r/, ‘broken’	/mkassr-i:n/

The underlined segments of the stem singulars are subjected to some phonological change when their corresponding SP forms are derived. There is a long final vowel in /ʔa:di:/ which is the result of the surfacing of the underlying glide. This glide has to surface in the derivation of SP as an onset to head the onsetless suffix /-i:n/. This is to say that the stem undergoes a phonological change which forces the final glide to surface with its vocalic features since the language does not allow consonantal glides in the final position. In the derivation of the SP, the glide undergoes a phonological change in order to force it to surface with its consonantal features. In the second example, /i/ in the singular /ha:ʒif/ is an epenthetic vowel associated with the derivation of the active participle. As mentioned earlier, as a result of infixing the active participle /a:/ in the active morphological site after C<sub>1</sub>, the resulting structure comes with two unsyllabified final root consonants. Consequently, the phonology repairs this structure by inserting the short vowel. However, when the SP is derived, this short vowel is lost due to a phonological constraint which requires the minimizing of the number of unstressed light syllables. Thus, there are many cases where the stem singular has to go through some phonological modification as a consequence of attaching the plural suffix.

As far as the morphological process of plurals is concerned, the question that should be asked concerns which constraints motivate a singular form to qualify for a SP or a BP form. There are many singular adjectival forms that only take SP, and there are restricted adjectival forms that only take BP. This is not to deny the possibility of an adjectival form qualifying for both plurals. The answer has in fact been provided by many CA grammarians (see Samirrai, 2007, for an exhaustive list). The answer lies in the grammatical distinction between the noun and the adjective, and specifically the distinction in meaning. CA grammarians argue that adjectives usually take SP and not BP. The qualification for an adjective to take SP and not BP starts from the SP suffixes which are similar to those that mark the derivation of the plural in verbs. Hence, there is a relation between a verb ending in such suffixes and an adjective which qualifies for the same suffixes. The shared meaning triggered by the plural suffixes in both the verb and the adjective is related to a temporary state or condition which refers to the action. Thus, the similarity between the verb and the adjective here is the time reference which limits the effect of the two to a specific closed period of time. In other words, an adjective which qualifies for a SP form is said to designate that this adjective denotes an action which does not last for long. If such an adjective loses the time reference, it is more likely to be considered as a noun, and consequently qualify for a BP form. To put this in relative terms, the closer the adjective is to the noun state, the more likely it is to qualify for BP; and the closer the adjective to the verb state, the more likely it is to qualify for SP (Samirrai, 2007, 126). Consider the following examples:

(336)	Singular adjective	SP	BP
	/qa:tɪl/, ‘murderer’	/qa:tɪl-i:n/	/qatalat/
	/ħazi:n/, ‘depressed’	/ħazi:n-i:n/	/ħaza:na:/

The SP in these examples refers to the actions, whereas the BP refers to the type or group of people who do these actions.

## 6.4 Conclusion

In the discussion of their derivation, it turns out that the non-concatenative morphological derivational process of adjectives is similar to that of nouns. The correspondence relations between the output derived adjective and that of the corresponding input, whatever the source of derivation, showed that there was a lack of complete correspondence between the two corresponding words. Comparable to the underlying structure of derived noun, the underlying structure of derived adjectives consists of root consonants plus the specified adjectival morpheme(s) in a parallel to the non-concatenative morphological process exhibited in the derivation of nouns. After the adjectival morphemes have targeted the active morphological sites associated with the derivational morphological nature of adjectives, the underlying structure of the derived adjective is formed. This underlying structure is repaired by the morphological and phonological constraints at the surface level, so that the optimal derived adjective candidate would be chosen based on satisfying the higher ranked constraints in the language.

## **Chapter 7: Non-concatenative Derived Broken Plurals in LA**

This chapter integrates the outcomes of the chapters on nouns and adjectives in order to explore the morphophonological nature of the input of the derived BP form. A similar account of the non-concatenative morphological processes proposed for the derivation of nouns and adjectives is put forward to account for the derivation of BP. Thus, the morphological process takes the root consonants and the associated morphological BP morphemes as the components of the underlying structure of the derived BP form. This chapter begins by giving a brief account of the previous studies of BP in LA. Then, the BP forms are divided into four categories based on the number of root consonants: biliteral, triliteral, quadriliteral, and quinqueliteral root consonants. Following this, loanwords in LA which qualify for BP are explained. Then, an investigation is presented to account for why some input singular forms have more than one possible BP form. The chapter concludes by accounting for the plural of the plural and the morpho-syntactic and morpho-semantic constraints that deprive a nominal form from qualifying for BP.

### **7.1 Introduction**

There are only a few studies of LA plural formation in general and of BP in particular. Most of the studies follow the descriptive approach of CA grammarians in such a way that they list the BP patterns in correspondence with their singular candidates. These studies are Elfitoury (1976), Abumdas (1985), Elgadi (1986), and Harrama (1993). Owens (1984) also presented a plural-singular correspondence account, but he attempted to account also for the status of the vowel of the BP pattern in relation to the vowel of its singular correspondent as well as some morphophonological processes such as the state of glides in the derivation of BP. However, he did not give any account of the motivation for the quality of the vowel in the BP form. Two other studies which deal specifically with the Sirt dialect (Al-Zoaby and Mohammed, 2005; Mohammed et al., 2006) which try to account for the affixational processes related to

BP formation as well as the vowel quality of the two corresponding forms. They interpreted the idea of the BP pattern in a syllabic weight by listing the singular forms in association with whether they qualify for monosyllabic, disyllabic, or trisyllabic forms. No assumption at all was made of correspondence relations between the input and the output, but they did look at BP formation as a consequence of the affixation type that transforms the singular to the BP template. Although they tried to give a tentative account of the morphophonological processes in the Sirt dialect, they were guilty of confusing of phonological and morphological motivations for vowels.

## 7.2 Biliteral Roots

The most productive number of root consonants in lexical words is found in the trilateral form. However, there are a few lexical words in LA that surface with two root consonants. These words are assumed to have a monomoraic structure at the underlying level while some are not considered moraic at all as in /bn/, ‘son’. This has the surface structure /ʔibn/, since it does not have a syllable at the underlying level. In the derivational morphology of such biliteral root words, they are always brought into conformity with the minimal prosodic requirement of the language which is the binarity structure (McCarthy and Prince, 1990b). In the derivation of BP, for example, these words exhibit infixational consonants, which are usually represented at the underlying structure as glides, in order to form well-formed syllables. A closer look at the BP forms and their corresponding singular forms below shows that all of the BP forms end in a long vowel /a :/ plus a glottal stop /ʔ/, for example:

(337) Underlying Roots	Singular Form	BP Form
√bn, ‘son’	/ʔ <sub>4</sub> ib <sub>1</sub> n <sub>2</sub> /	/ʔ <sub>4</sub> ab <sub>1</sub> n <sub>2</sub> a : ʔ <sub>5</sub> /
√ʔb, ‘father’	/ʔ <sub>1</sub> ab <sub>2</sub> /	/ʔ <sub>1</sub> ab <sub>2</sub> a : ʔ <sub>5</sub> /
√sm, ‘name’	/ʔ <sub>4</sub> is <sub>1</sub> m <sub>2</sub> /	/ʔ <sub>4</sub> as <sub>1</sub> m <sub>2</sub> a : ʔ <sub>5</sub> /
√dm, ‘blood’	/d <sub>1</sub> am <sub>2</sub> /	/d <sub>1</sub> im <sub>2</sub> a : ʔ <sub>5</sub> /

The BP morpheme /a :/ identifies the active morphological site after C<sub>2</sub>, as all the BP forms show. Now, the question is why these plurals end in a glottal stop. There could

be two reasons for this: either the glottal stop is epenthetic to prevent the length of the final resulting long vowel, which is the BP morpheme, from shortening; or the glottal stop actually corresponds to an underlying glide /w/. In fact, both reasons could be true. On the one hand, the BP morpheme is subject to shortening and, since this morpheme is a morphological component, the shortening process leads to the loss of the morphological process because the short vowel does not and cannot compensate the BP morpheme /a:/. On the other hand, the existence of a glide in the underlying structure can be observed in the formation of SP in these words, for example:

(338)	Singular Form	SP Form
	/ʔ <sub>4</sub> i s <sub>1</sub> m <sub>2</sub> /	/ʔ <sub>4</sub> i s <sub>1</sub> m <sub>2</sub> a w <sub>3</sub> -a:t/
	/d <sub>1</sub> a m <sub>2</sub> /	/ʔ <sub>4</sub> i d <sub>1</sub> m <sub>2</sub> a w <sub>3</sub> -a:t/

As a matter of fact, √bn could be considered as having at the underlying level a trilateral form because of the way it forms its BP form. The length of the vowel and the glottal stop in the final position suggest that the glottal stop is the compensation for the underlying glide. In the derivation of SP of /ʔ<sub>4</sub>i s<sub>1</sub>m<sub>2</sub>/ and /d<sub>1</sub>a m<sub>2</sub>/, the SP suffix /a:t/ is augmented to the glide /w/. The glide surfaces here for two reasons: it is no longer in final position; and due to the constraint \*2<sub>CONSONANTS</sub> which requires the derived word to have minimally three consonants. In this case, minimality is satisfied by virtue of the surfacing of the underlying glide.

The underlying glide of words which have the surface structure of biconsonantal root words is forced to surface in the derivation of the collective noun as well as in the derivation of BP. Consider the derivation of the collective noun and the BP forms of the singular form /ʔ<sub>1</sub>a x<sub>2</sub>/:

(339)	Underlying root	Singular Form	Collective Plural	BP
	√ʔx, 'brother'	/ʔ <sub>1</sub> a x <sub>2</sub> /	/ʔ <sub>1</sub> i x <sub>2</sub> w <sub>3</sub> -at/	/ʔ <sub>1</sub> i x <sub>2</sub> w <sub>3</sub> a:n/

In both the collective and the BP nouns, the glide surfaces in the position of the onset of the syllable that hosts the plural marker. However, the motivation for such

surfacing is different in the two forms: in the collective noun, the glide surfaces to satisfy the rule of minimal root consonants in the derived noun; in the BP form, the glide surfaces because it represents the active morphological site that hosts the BP morpheme.

The singular /ʔ<sub>4</sub>ib<sub>1</sub>n<sub>2</sub>/ can represent an illustrative example for similar forms. It is assumed that this singular is at the underlying level triconsonantal; otherwise the structure of the optimal output BP form cannot be justifiable:

(340)

Input: [bnâ : w]	*COMPLEX	*GLIDE] <sub>STEM</sub>	*VV] <sub>STEM</sub>	*2 <sub>CONSONANTS</sub>	IDENT
a. → /ʔ <sub>4</sub> ab <sub>1</sub> .n <sub>2</sub> a : ʔ <sub>5</sub> /					*
b. /ʔ <sub>4</sub> ab <sub>1</sub> .n <sub>2</sub> a : /			*!	*	
c. /ʔ <sub>4</sub> ab <sub>1</sub> .n <sub>2</sub> a : w <sub>3</sub> /		*!			
d. /b <sub>1</sub> n <sub>2</sub> a : ʔ <sub>5</sub> /	*!				*

Candidate (d) is ruled out by the top ranked constraint \*COMPLEX, which is assumed to come into play first after any derivational morphological process. The other three markedness constraints rule out both candidates (c) and (b). Candidate (c) is disregarded due to the fact that it maintains the third root consonant glide in the final position, which is not permitted. Candidate (b) performs better than (c), but deletes the glide in which the long vowel BP morpheme is subject to shortening. Candidate (a) shows that the optimal way is to compensate for the final glide with an epenthetic glottal stop by which all the markedness constraints are satisfied. However, the cost of this process leads to a lack of identity between the root consonants of the output with those of the input (i.e. the glide). This should cause no problem so long as the identity constraint is low-ranked.

The derivational morphological process often reveals traces of the underlying form which do not show up in the surface singular forms, but they are forced to surface in the derived BP output forms by the force of markedness constraints. Thus, the identity of the root consonants of the surface input seems, at first glance, to not correspond to those of the derived output. In fact this is often the case and working backwards from the output derived word to its corresponding input is more revealing.

### 7.3 Triliteral Root Consonants

The main focus in this section is the formation of BP of nouns and adjectives which are derived from triliteral root consonants. The morphological and phonological processes associated with BP are explored and investigated. The main goal is to account for the consequences of identifying the morphological active sites and the morphological morphemes that mark BP formation. Furthermore, after the morphology takes place, it is essential to consider the role of phonological processes which shape the well-formed nature of the derived BP word. The argument will consistently oppose the notion of the existence of templatic patterns which have previously been associated with the formation of BP. Templates in this thesis are seen as the result of phonological markedness constraints which well-form the possible surface candidates of the underlying input supplied by the morphological process.

In order to explain the formation of BP, the data is presented in BP form and its corresponding source of derivation which is usually the singular nominal form. It must be re-emphasized that the correspondence relationship between a BP form and its singular correspondent holds only for the root consonants, long vowels, and any morphological morpheme transferred from the singular. We will see that the phonological processes of the input (singular) play no role in the output (plural). Thus, the form given as an input (underlying structure) is the root consonants, any morphological morpheme associated with the singular, and the BP morpheme/s. The output is represented in its optimal form and constraints on all of the active phonological processes are presented and discussed for each BP form.

#### 7.3.1 Form /C<sub>4</sub>uC<sub>1</sub>C<sub>2</sub>u:C<sub>3</sub>/

This BP form is derived by infixing the BP morpheme in the active morphological site identified by the BP form which is positioned between C<sub>2</sub> and C<sub>3</sub>. The initial epenthetic glottal stop is inserted to syllabify C<sub>1</sub> which, as a result of the BP derivational process, is left unparsed. Consider the following examples:



a. /C<sub>1</sub>aC<sub>2</sub>aC<sub>3</sub>/

- (341) /g<sub>1</sub>al<sub>2</sub>ab<sub>3</sub>/, ‘heart’ /ʔ<sub>4</sub>ug<sub>1</sub>l<sub>2</sub>u:b<sub>3</sub>/  
 /ð<sup>ʕ</sup><sub>1</sub>ar<sub>2</sub>af<sub>3</sub>/, ‘circumstance’ /ʔ<sub>4</sub>uð<sup>ʕ</sup><sub>1</sub>r<sub>2</sub>u:f<sub>3</sub>/

b. /C<sub>1</sub>iC<sub>2</sub>iC<sub>3</sub>/

- (342) /s<sub>1</sub>iʒ<sub>2</sub>in<sub>3</sub>/, ‘prison’ /ʔ<sub>4</sub>is<sub>1</sub>ʒ<sub>2</sub>u:n<sub>3</sub>/  
 /n<sub>1</sub>is<sub>2</sub>ir<sub>3</sub>/, ‘vulture’ /ʔ<sub>4</sub>in<sub>1</sub>s<sub>2</sub>u:r<sub>3</sub>/

c. /C<sub>1</sub>aC<sub>2</sub>iC<sub>3</sub>/

- (343) /m<sub>1</sub>al<sub>2</sub>ik<sub>3</sub>/, ‘king’ /ʔ<sub>4</sub>im<sub>1</sub>l<sub>2</sub>u:k<sub>3</sub>/  
 /ʒ<sub>1</sub>ar<sub>2</sub>id<sub>3</sub>/, ‘traditional robe’ /ʔ<sub>4</sub>iʒ<sub>1</sub>r<sub>2</sub>u:d<sub>3</sub>/

In (341, 342, and 343), it is obvious that the short vowels of the singular do not correspond to the vowels of the plural. The quality of the epenthetic short vowel in the plural is /i/, but it is subject to change according to the environment. As in (341), the quality of the vowel is shaped by the environment of back features triggered by the back consonant and the emphatic consonant.

Let us take /ʔ<sub>4</sub>ug<sub>1</sub>l<sub>2</sub>u:b<sub>3</sub>/ as an example. The tableau below shows three possible candidates. Candidate (c) is ruled out because it violates the higher ranked constraint which militates against consonant clusters. Candidate (b) also violates the other equivalent higher constraint which militates against open light syllables. The optimal candidate (a) satisfies both higher ranked constraints at the price of violating the low ranked constraint which militates against epenthetic segments:

(344)

Input: [g <sub>1</sub> l <sub>2</sub> u <sup>h</sup> :b <sub>3</sub> ]	*COMPLEX	*Cv] <sub>σ</sub>	DEP
a. → /ʔ <sub>4</sub> ug <sub>1</sub> .l <sub>2</sub> u:b <sub>3</sub> /			**
b. /g <sub>1</sub> u.l <sub>2</sub> u:b <sub>3</sub> /		*!	
c. /g <sub>1</sub> l <sub>2</sub> u:b <sub>3</sub> /	*!		





A word with geminated final consonants is considered a biliteral word in the abstract representation of the autosegmental association of segments (McCarthy, 1979, 1981; Hoberman, 1988). If the segments are associated with a template in a case such as this, the second root consonant spreads to fill the third slot of the template. In other words, a monosyllabic word with final geminated root consonants is at the underlying level represented as disyllabic. But due to a syncope process in which the second vowel separates the geminated consonants, the underlying form surfaces as monosyllabic with final geminated consonants together standing in a coda position (Brame, 1970). What is interesting as far as BP is concerned is the fact that the BP morpheme identifies the first part of the geminated consonant as C<sub>2</sub> and not the second part. The other interesting fact is the preservation of the local spreading of the geminated consonants. This spreading is preserved by localizing the geminated consonants within the same syllable that contains the geminated consonants.

### 7.3.2 Form /C<sub>4</sub>iC<sub>1</sub>C<sub>2</sub>a:C<sub>3</sub>/

The structure of this pattern is similar to the previous one but with a change in the quality of the BP morpheme. Here, the morpheme surfaces as /a:/. The initial cluster resulting from BP derivation is avoided by the epenthetic glottal stop, for example:

- a. /C<sub>1</sub>aC<sub>2</sub>aC<sub>3</sub>/
- (349)      /ʒ<sub>1</sub>ab<sub>2</sub>a<sub>l3</sub>/, ‘mountain’                      /ʔ<sub>4</sub>iʒ<sub>1</sub>b<sub>2</sub>a:l<sub>3</sub>/
- / k<sub>1</sub>a<sub>l2</sub>ab<sub>3</sub>/, ‘dog’                                /ʔ<sub>4</sub>ik<sub>1</sub>l<sub>2</sub>a:b<sub>3</sub>/

In the examples below, the initial long vowel /u:/ is the surface realization of the glide /w/. The underlying structure for the BP form is /w<sub>1</sub>a<sub>l2</sub>a:d<sub>3</sub>/, but in LA the glide in such positions is forced to surface with its vocalic features. This might be triggered by the fact that the stress is assigned to the final heavy syllable. And since the light syllable which contains the glide is unstressed and the language avoids unstressed light syllables, the glide surfaces with its vocalic features. Consider the following examples:







/b<sub>1</sub>a:b<sub>3</sub>/, ‘door’

/ʔ<sub>4</sub>i b<sub>1</sub>w<sub>2</sub>a:b<sub>3</sub>/

f. /C<sub>1</sub>aC<sub>2</sub>i:C<sub>3</sub>/

The derivation of the BP of this singular is very interesting and it gives some insight into the active morphological sites associated with the derivational morphology of the language. Here, the singular form is an adjective associated with the adjectival morpheme /i:/ hosted between the root consonants C<sub>2</sub> and C<sub>3</sub>, and its derived corresponding BP adjective is associated with the BP morpheme /a:/ which occupies the same morphological site that hosts the adjectival morpheme in the corresponding singular form. Consider the following examples:

(358)            /ʔ<sub>1</sub>a f<sub>2</sub>i:f<sub>3</sub>/, ‘virtuous’            /ʔ<sub>4</sub>i ʔ<sub>1</sub>f<sub>2</sub>a:f<sub>3</sub>/  
                  /k<sub>1</sub>a b<sub>2</sub>i:r<sub>3</sub>/, ‘big’                /ʔ<sub>4</sub>i k<sub>1</sub>b<sub>2</sub>ɑ:r<sub>3</sub>/

The fact that the long vowel of the singular is not transferred to the BP form is attributed to a morphosyntactic constraint that militates against the existence of more than one morpheme within one active morphological site. This constraint must be undominated; otherwise a morphological site may cause an ill-formed syllable which is in this case a syllable with four moras created by the two morphemes. The constraint can be defined as follows:

\*MORPHEME-CLASH: a morphological site must not be occupied by more than one morpheme.

The function of this constraint is to militate against the double marking of grammatical categories more than once within a stem. As a matter of fact, the adjective qualifies for BP only by virtue of acquiring a noun state. Thus, the deletion of the adjectival morpheme /i:/ is grammatically constrained, since in addition to its nature as a plural marker, the BP morpheme /a:/ also grammatically marks the noun.



### 7.3.3 Form /C<sub>1</sub>vC<sub>2</sub>C<sub>3</sub>a:C<sub>4</sub>/

The initial short vowel is at the underlying level /u/, but LA generally tends to raise it to /i/. There are two further morphological processes associated with this BP form. The first is that the active morphological site for the BP is identified after the third root consonant; and the second is the insertion of the suffix /n/ in the coda position of the last syllable. If the second root consonant of this form is underlyingly a glide /w/, then this glide surfaces with its vocalic features to form a long vowel. But as can be seen from the corresponding BP forms, this glide does not actually surface with its identical features but rather it undergoes glide-fronting. Consider the examples (359) and (360) below:

a. /C<sub>1</sub>u:C<sub>3</sub>/

- |       |   |   |
|-------|---|---|
| (359) | /ħ <sub>1</sub> u:t <sub>3</sub> /, ‘whale’                           | /ħ <sub>1</sub> i:t <sub>3</sub> a:n <sub>4</sub> /                           |
|       | /s <sup>ʔ</sup> <sub>1</sub> u:s <sup>ʔ</sup> <sub>3</sub> /, ‘chick’ | /s <sup>ʔ</sup> <sub>1</sub> i:s <sup>ʔ</sup> <sub>3</sub> a:n <sub>4</sub> / |

b. /C<sub>1</sub>a:C<sub>3</sub>/

- |       |   |   |
|-------|---|---|
| (360) | /ʒ <sub>1</sub> ɑ:r <sub>3</sub> /, ‘neighbour’ | /ʒ <sub>1</sub> i:r <sub>3</sub> a:n <sub>4</sub> / |
|       | /n <sub>1</sub> ɑ:r <sub>3</sub> /, ‘fire’      | /n <sub>1</sub> i:r <sub>3</sub> a:n <sub>4</sub> / |

The actual surfacing of an underlying glide is not a straightforward process. The singular forms above in (359) and (360) show multiple choices of the surface features of the underlying glide. In (359), the underlying backness feature of the glide spreads to the preceding vowel /a/ to form a long back vowel at the surface; while in (360) the low vowel spreads to the glide creating a long low vowel at the surface. However, the identical features of the glide either as vocalic or consonantal in the singular are not maintained in the corresponding BP form. The long front vowel /i:/ suggests that it is the surface vocalic feature of the underlying glide /j/. This cannot be the case, since from the root consonants it is clear that the underlying glide is /w/. The fronting of a back glide is not only common in LA but is also productive in the derivational morphology of CA (Ibn Jinni, 1954, Vol. I, 344-350; Abaas, 1963, Vol. IV, 776-783).

Taking / ħ<sub>1</sub>i : t<sub>3</sub>a : n<sub>4</sub>/ as an example, its derivation is worked out in the following tableau:

(361)

Input: [ħwtâ : ñ ]	{U, I}=μ	GLIDE-FRONTING	IDENT-C
a. → / ħ <sub>1</sub> i : t <sub>3</sub> a : n <sub>4</sub> /			*
b. / ħ <sub>1</sub> u : t <sub>3</sub> a : n <sub>4</sub> /		*!	
c. / ħ <sub>1</sub> i w . t <sub>3</sub> a : n <sub>4</sub> /	*!	*	

The surface representation of the glide is shaped by the two higher ranked constraints {U, I}=μ and GLIDE-FRONTING. The first requires the glide to surface with its vocalic features; and the second requires it to undergo fronting. In candidate (c), the glide surfaces with its consonantal features, in a fatal violation of the higher ranked constraint. Although in candidate (b) the glide surfaces with vocalic features and is faithful to the features of the glide, does not satisfy the requirement to undergo fronting. Consequently, it is ruled out by the GLIDE-FRONTING constraint. The winning candidate (a) violates the identity constraint but wins since GLIDE-FRONTING dominates IDENT-C.

In the preceding tableau, there is an issue not addressed so far, since its main concern is the surface structure of the glide. This issue is the epenthetic /n/. It seems that the instability of the glide in the C<sub>2</sub> position motivates the shift of the BP morpheme to be hosted after C<sub>3</sub>. Aligning the long vowel at the right edge of the word means that this long vowel is subject to vowel shortening in the final position, which is a productive phonological process in LA. However, such a shortening leads to the shortening of the BP morpheme which is assigned by the morphology. Any deletion of morphological elements by phonology causes failure to identify the morphological process. To avoid shortening, the epenthetic /n/ is inserted to create a heavy closed syllable and, subsequently, a shortening of the long vowel does not take place. In Arabic there are generally two epenthetic consonants which may be inserted in such circumstances: /n/ and /ʔ/. /ʔ/ in the final position is often associated with feminine adjectives, nouns, and as a realization of glide [w] in stem final position, while /n/ is often associated



d. /C<sub>1</sub>aC<sub>2</sub>u:C<sub>3</sub>/

- (364) /g<sub>1</sub>αf<sub>2</sub>u:d<sub>3</sub>/, ‘young camel’                      /g<sub>1</sub>i f<sub>2</sub>d<sub>3</sub>a:n<sub>4</sub>/  
           /x<sub>1</sub>a r<sub>2</sub>u:f<sub>3</sub>/, ‘male sheep’                         /x<sub>1</sub>i r<sub>2</sub>f<sub>3</sub>a:n<sub>4</sub>/

e. /C<sub>1</sub>a:C<sub>2</sub>i: /

- (365) /r<sub>1</sub>a:f<sub>2</sub>i:/, ‘shepherd’                                 /r<sub>1</sub>i f<sub>2</sub>j<sub>3</sub>a:n<sub>4</sub>/  
           /w<sub>1</sub>a:d<sub>2</sub>i:/, ‘valley’                                    /w<sub>1</sub>i d<sub>2</sub>j<sub>3</sub>a:n<sub>4</sub>/

Some of the singular forms have more than one BP candidate. Consider the following examples:

- |       |   |  |  |  |
|-------|---|--|--|--|
| (366) | Singular Form                                       | 1 <sup>st</sup> BP Candidate   | 2 <sup>nd</sup> BP Candidate                                       | 3 <sup>rd</sup> BP Candidate                                       |
|       | /f <sub>1</sub> a:r <sub>2</sub> i s <sub>3</sub> / | /f <sub>1</sub> a w <sub>4</sub> a:r <sub>2</sub> i s <sub>3</sub> / | /f <sub>1</sub> u r <sub>2</sub> s <sub>3</sub> a:n <sub>4</sub> / | -  |
|       | /r <sub>1</sub> a:f <sub>2</sub> i:/                | /r <sub>1</sub> a w <sub>4</sub> a:f <sub>2</sub> i:/                | /r <sub>1</sub> u f <sub>2</sub> a:t <sub>4</sub> /                | /r <sub>1</sub> i f <sub>2</sub> j <sub>3</sub> a:n <sub>4</sub> / |

In the discussion of the possibility of a singular candidate qualifying for more than one BP form, it will become clear that such a qualification is restricted and distinguished by a difference in meaning between the BP candidates. The suffix /n/ in the BP form is motivated and justified by morpho-semantic requirements. The function of the suffix /n/ is to designate that the individuals being pluralized are considered to be one group of individuals. The function of /n/ is twofold: changing the grammatical category to nouns; and designating the sense of a collective noun in such a way that the individuals are seen as equal within one group.

### 7.3.4 Form /C<sub>1</sub>iC<sub>2</sub>C<sub>2</sub>a:C<sub>3</sub>/

This BP form exhibits gemination of the second root consonant. In Arabic, geminating the second root consonant generally has semantic significance. It refers to the intensiveness and extensiveness of an action which lasts for a long period of time (Wright, 2005, Vol. I, 31). This BP form is generally associated with the plural of the active participle. Although the derivation of such a medially geminated BP form can

be assumed to be derived from a corresponding medially geminated singular form, this BP form is derived from singular forms where the medial root consonant is not geminated. For example, the geminated consonants in /t<sub>1</sub>i<sub>3</sub>z<sub>2</sub>a:r<sub>3</sub>/ do not have correspondents in the singular /t<sub>1</sub>a:z<sub>2</sub>i:r<sub>3</sub>/, because there is no geminated form of this singular. So, a plausible justification is to assume that geminated medial root consonants are motivated by a morpho-semantic derivational process. Consider the following examples:

a. /C<sub>1</sub>a:C<sub>2</sub>iC<sub>3</sub>/

(367)	/z <sub>1</sub> a:h <sub>2</sub> il <sub>3</sub> /, ‘ignorant’	/z <sub>1</sub> ih <sub>2</sub> h <sub>2</sub> a:l <sub>3</sub> /
	/t <sub>1</sub> a:z <sub>2</sub> i:r <sub>3</sub> /, ‘merchant’	/t <sub>1</sub> i <sub>3</sub> z <sub>2</sub> a:r <sub>3</sub> /

In CA, the initial short vowel tagged with this form is /u/. The fronting of the vowel to /i/ is a phonological process in LA which tends to front the back vowel /u/ (Abumdas, 1985, 238-239). The long vowel of the singular which marks the derivation of the active participle is not transferred to the BP. This can be attributed to the fact that the position of the second root consonant is already occupied by the geminated consonant. The morphological gemination process is assumed to be triggered by the identification of an empty inserted C-slot, which has the function of a derivational site, and the spreading of the geminated consonant is to fill that C-slot (Guerssel and Lowenstamm, 1990; Idrissi, 1997; Kihm, 2006). The obligatory contour principle (OCP) (Leben, 1973; McCarthy and Prince, 1986) which prohibits the adjacency of identical autosegments seems to cause a problem in the parsing of geminated consonants. However, this may not cause problems for two reasons: the first is that the inserted C-slot is at the underlying level represented as /CV/, so that the association or lack of association of autosegmental elements can be attributed to any phonological process, such as the syncope of the unstressed short vowel; the second is the fact that these geminated consonants are separated by a syllable boundary. As can be seen from the BP forms, the geminated consonants are represented as long-distance autosegmental spreading. That is to say, the geminated consonants cannot be hosted within one syllable, but rather they are spreaded into separate syllables. As a result, the only possible position for the BP morpheme is to be

hosted between the second part of the geminated consonant and the third root consonant. Before taking /ʒ<sub>1</sub>i.h<sub>2</sub>h<sub>2</sub>a:l<sub>3</sub>/ as an example and considering its derivation, two constraints must be introduced:

OCP: A sequence of adjacent identical segments is disallowed (under consonant adjacency).

\*CVCV: A sequence of two unstressed open light syllables is disallowed.

(368)

Input: [ʒ <sup>h</sup> h <sup>h</sup> : l]	OCP	*COMPLEX	*CVCV	ONSET	DEP
a. → /ʒ <sub>1</sub> i.h <sub>2</sub> .h <sub>2</sub> a:l <sub>3</sub> /					*
b. /ʒ <sub>1</sub> i.h <sub>2</sub> a.h <sub>2</sub> a:l <sub>3</sub> /			*!		**
c. /ʒ <sub>1</sub> i.h <sub>2</sub> h <sub>2</sub> .a:l <sub>3</sub> /	*!	*		*	*
d. /ʒ <sub>1</sub> i.h <sub>2</sub> h <sub>2</sub> a:l <sub>3</sub> /	*!	*			*

In the tableau, both constraints OCP and \*COMPLEX are equally ranked because any violation of OCP will consequently create a consonant cluster in violation of \*COMPLEX. Candidates (d) and (c) parse the geminated consonants as a complex onset and a complex coda respectively. Thus, they are ruled out by these two constraints. Notice that any misplacement of the geminated consonants may cause an ill-formed syllable as is the case with candidate (c). Candidate (b) does not violate any of these constraints since both geminated consonants are parsed in different syllables. Recall that stress falls on the heavy syllable. However, in order to satisfy OCP by syllabifying the first geminated consonant in a light syllable and the second in a heavy syllable, candidate (b) commits a violation of the constraint \*CVCV which militates against any string of unstressed open light syllables. The optimal candidate (a) syllabifies the first geminated consonant as a mora linked to the preceding syllable, and thus it satisfies all the constraints.

The OCP seems to play a vital role in forcing the spreading of the geminated consonants in such a way that they are separated by a distance. In this case, the optimal distance is the syllable boundary. It is interesting to observe that the second part of the geminated consonant is considered as the sole root consonant, since the BP morpheme identifies it as the onset of the syllable of the active morphological site. The first part, on the other hand, is syllabified by the phonology but its morphological

function in relation to the second is maintained as long as both segments stay close to each other while at the same time being separate. The only way to achieve these conditions is within the syllable boundaries of the word. This should not cause a problem since the binarity of the syllable is also satisfied.

### 7.3.5 Form /C<sub>1</sub>aC<sub>4</sub>a:C<sub>2</sub>iC<sub>3</sub>/

This form of BP is mainly restricted to the active participle singular of the form /Ca:CiC/. The morpheme of the active participle positioned after C<sub>1</sub> of the singular is realized as a glide /w/ in the derivation of BP. This glide takes the position of C<sub>2</sub> of the BP form. In templatic morphology (McCarthy, 1979; Yip, 1988; Hammond, 1988; McCarthy and Prince, 1990a) and in prosodic morphology (McCarthy and Prince, 1990b; McCarthy, 1997; Watson, 2002), this glide is considered an epenthetic consonant to fill an empty onset. However, it seems that there is a relation between the long vowel and its surfacing as a glide. It is widely observed that long vowels are usually transferred in the process of derivational morphology since they usually carry a morphological property. The failure of transfer is attributed to the fact that the active morphological site is already occupied by another morphological morpheme, as is the case with BP when C<sub>2</sub> is filled by the BP morpheme. In the availability of a derivation site, the morphological properties of the input are carried over to the output derived word.

It has also been widely observed that long vowels and glides are underlyingly represented as a sequence of two moras. In long vowels, this is a sequence of two homorganic vowels, while in glides it is a diphthong which is a sequence of a vowel plus a homorganic glide (Brame, 1970, 132; Rosenthal, 2006, 408). Thus, both long vowels and glides are underlyingly vocoids and the difference is only in the surface representation where the glides can either surface as vowels or with their extra consonantal features. It is assumed that glides alternate with high vowels in Arabic, but high vowels do not alternate with glides (Rosenthal, 2006, 408). The derivation of BP motivates the assumption that long vowels are underlyingly represented as diphthongs. In one case the underlying diphthong surfaces as a glide, and in the second it surfaces as a vowel. Consider the following examples:

a. /C<sub>1</sub>a:C<sub>2</sub>iC<sub>3</sub>/

- (369)        /ħ<sub>1</sub>a:m<sub>2</sub>il<sub>3</sub>/, ‘pregnant’                      /ħ<sub>1</sub>aw<sub>4</sub>a:m<sub>2</sub>il<sub>3</sub>/  
                  /ʒ<sub>1</sub>a:m<sub>2</sub>iʔ<sub>3</sub>/, ‘mosque’                      /ʒ<sub>1</sub>aw<sub>4</sub>a:m<sub>2</sub>iʔ<sub>3</sub>/

b. /C<sub>1</sub>a:C<sub>2</sub>iC<sub>3</sub>-at/

- (370)        /q<sub>1</sub>a:f<sub>2</sub>il<sub>3</sub>-at/, ‘caravan’                      /q<sub>1</sub>aw<sub>4</sub>ɑ:f<sub>2</sub>il<sub>3</sub>/  
                  /z<sub>1</sub>a:j<sub>2</sub>l<sub>3</sub>-at/, ‘she-camel’                      /z<sub>1</sub>aw<sub>4</sub>a:j<sub>2</sub>il<sub>3</sub>/

c. /C<sub>1</sub>a:C<sub>3</sub>-at/

- (371)        /ʔ<sub>1</sub>a:z<sub>3</sub>-at/, ‘necessity’                      /ʔ<sub>1</sub>aw<sub>4</sub>a:j<sub>5</sub>iʒ<sub>3</sub>/  
                  /ħ<sub>1</sub>a:ʒ<sub>3</sub>-at/, ‘need/thing’                      /ħ<sub>1</sub>aw<sub>4</sub>a:j<sub>5</sub>iʒ<sub>3</sub>/

d. /C<sub>1</sub>a:C<sub>2</sub>i:C<sub>4</sub>-at/

- (372)        /t<sup>ʔ</sup><sub>1</sub>ɑ:g<sub>2</sub>i:j<sub>4</sub>-at/, ‘hat’                      /t<sup>ʔ</sup><sub>1</sub>aw<sub>4</sub>ɑ:g<sub>2</sub>i:j/

The long vowel in the singular forms (a) – (d) surfaces as a glide /w/ in the corresponding BP forms. Following Brame (1970) and Rosenthal (2006), it is assumed that the quality of the surface glide is underlyingly represented as /u/. In the singular form, the low long vowel is shaped by the spreading of the features of the short vowel /a/ over to the features of underlying glide /u/ forced by the constraint MAX- {A} suggested earlier, creating the long vowel /a:/. The feature maximality adopted in this thesis refers to the maximal preservation of the identified feature and its spreading to any other neighbouring feature. In other words, this constraint has two functions: the preservation and spreading of features. For the derivation of the active participle, the low long vowel is achieved by the constraint MAX- {A}. In the derivation of its corresponding BP form, however, the underlying glide has to surface with its consonantal features in an onset position. Interestingly, this onset takes the position of C<sub>2</sub> of the string of word consonants. The consequence of such a realization of this onset forces the BP morpheme to identify it as the onset of the active



morphological site. This is not the case with the previous BP forms where the BP morpheme realizes C<sub>2</sub> of the root consonants as the onset of the syllable of the morphological site. This fact can be taken as evidence that glide formation takes place before the derivation of BP. Otherwise, the failure to identify the glide leads the BP morpheme to identify C<sub>2</sub> of the root consonants as the onset host, which consequently leads to an ill-formed word.

An illustrative example shows the surface realization of the glide in the morphological process of deriving BP. Ignore for now the other unrelated phonological process of the epenthetic glide /j/ in the third syllable in the set of examples in (b) and (c), since this is discussed in other BP forms:

(373)

Input: [ħwâ : ml]	GLIDE=ONSET	{U}=μ
a. → /ħ <sub>1</sub> a.w <sub>4</sub> a : .m <sub>2</sub> il <sub>3</sub> /		*
b. /ħ <sub>1</sub> u.m <sub>2</sub> a : l <sub>3</sub> /	*!	

The tableau shows that, in order to achieve the right position for the BP morpheme, the glide must surface with its consonantal feature. This feature is tagged with the subscripted number 4 in the tableau to distinguish it from the root consonant subscripted with the number 2. In candidate (b), the glide surfaces with its vocalic features, causing the BP morpheme to identify C<sub>2</sub> of the root consonants as a host. That subsequently creates an ill-formed word. So, unless the constraint GLIDE=ONSET dominates {U}=μ, the right position of the BP will not be recognized.

The discussion now turns to the vocalic realization of the glide as a result of a morphophonological process. The singular forms in (e) below have a glide /j/ in C<sub>3</sub> position. This glide surfaces as a long vowel and, since it is in the final position, it is subject to vowel shortening. However, for ease of reference the long vowel is retained as a correspondent to the glide, for example:

e. /C<sub>1</sub>a : C<sub>2</sub>i : /

(374)                    /q<sub>1</sub>ɑ : d<sup>ɛ</sup><sub>2</sub>i : /, ‘judge’                    /q<sub>1</sub>ud<sup>ɛ</sup><sub>2</sub>a : t<sub>4</sub>/

/ʒ<sub>1</sub>a:n<sub>2</sub>i:/, ‘convicted person’    /ʒ<sub>1</sub>un<sub>2</sub>a:t<sub>4</sub>/

There are three possible realizations of the underlying glide /j/ in the final position: full consonantal features, vocalic features, or deletion. This phonological process is not only active in LA, but also in CA (Abaas, 1963, 645; Bakkuush, 1987, 163; Wright, 2005, Vol. I, 88) and in CA (Brame, 1970, 36; Levy, 1971, 117). In the derivation of BP forms in (e), neither the consonantal nor the vocalic features of the glide /j/ are transferred from their corresponding singulars. In addition, the initial long vowel of the singular forms, which is the active participle morpheme, surfaces as a short vowel /u/ in the BP forms. This short vowel is actually the vocalic realization of the underlying glide /w/. The association between the long vowel /a:/ of the singular active participle forms and the glide /w/ in their corresponding BP forms gives reasonable evidence that the long vowel is at the underlying level represented as a glide. Examples (a) – (d) represent the consonantal features of this glide, while (e) represent the surface of the vocalic features.

The suffix /t/ is not the feminine marker as these BP forms have masculine gender. It is not clear whether or not this suffix has a syntactic function. That is to say, it is not clear whether it distinguishes an adjective from a noun. However, the obvious phonological function of this suffix is to maintain the length of the final long vowel, otherwise such length would be subject to shortening. Consider this tableau:

(375)

Input: [qûd <sup>ʒ</sup> â:j]	{U, I}=μ	*[j] <sub>STEM</sub>	*V: <sub>STEM</sub>	MAX-V- LONG	DEP	IDENT-C
a. → /q <sub>1</sub> ud <sup>ʒ</sup> <sub>2</sub> a:t <sub>4</sub> /						*
b. /q <sub>1</sub> ud <sup>ʒ</sup> <sub>2</sub> a:j <sub>3</sub> /		*!				
c. /q <sub>1</sub> ud <sup>ʒ</sup> <sub>2</sub> a:/			*!			*
d. /q <sub>1</sub> ud <sup>ʒ</sup> <sub>2</sub> a/				*!		*

The input which represents the underlying form has two glides: the first is the morpheme that marks the active participle which surfaces in the singular form as /a:/; the second is the root consonant /j/ in the final position. Because the first glide

surfaces as vocalic and the second is subject to deletion, the constraint  $\{U, I\}=\mu$  has to simultaneously check that the glides surface with their vocalic features. The identification of  $C_2$  as the host of the BP morpheme forces the glides to surface as vocalic. The first glide is syllabified with the first root consonant as its onset; the second has the choice of either deletion or realization as moraic in which it creates a trimoraic structure. These choices are represented in the tableau by four possible candidates. Candidate (d) is ruled out because of the shortening of the long vowel which marks the BP. However, candidate (c) preserves the length but is ruled out by the constraint which militates against long vowels in the final position. For a moment these two constraints seem to contradict each other. The only way to satisfy them is by constructing a closed syllable to prevent the shortening and at the same time preserving the length of the long vowel. This appears to be a case of interaction between the phonology and the morphology in the derivation of BP where the language tends to suffix a consonant so as to close any open heavy syllable. Candidates (b) and (a) both have closed syllables, but there is a problem with candidate (b). The realization of the glide as vocalic causes a trimoraic structure which is not permitted in the language. Also, its realization as consonantal violates the constraint which militates against final glides. Nevertheless, in order for candidate (a) to be optimal, the constraint DEP must dominate the constraint IDENT-C. In this way, the identity of the glide /j/ is sacrificed in favour of another epenthetic consonant.

### 7.3.6 Form /C<sub>1</sub>uC<sub>2</sub>aC<sub>3</sub>a:C<sub>4</sub>/

This BP form is generally restricted to the plural form of the singular verbal adjectives / C<sub>1</sub>a:C<sub>2</sub>iC<sub>3</sub>/ and / C<sub>1</sub>aC<sub>2</sub>i:C<sub>3</sub>/. The singular forms denote masculine rational beings and also designate the good or bad instinctive nature of the doer. None of the root consonants of this form exhibit a glide or geminated consonants. There are two morphological constructions associated with such BP forms: the active morphological site is located after C<sub>3</sub>; and the vowel associated with C<sub>1</sub> is marked as /u/. Interestingly, the long vowels of the singulars which determine the adjectival category are not transferred to the BP form. The syllabic structure of this BP form is trisyllabic. In the last syllable, the nucleus is filled by the BP morpheme which creates a heavy syllable. The vowels of the other two light syllables are supplied as follows: the vowel

/u/ in the first syllable is introduced by the morphology since this BP form is always associated with this vowel; the vowel /a/ of the second syllable is filled by the phonology either by default or to avoid the occurrence of two inhomogeneous high vowels within one foot. Consider the following examples:

a. /C<sub>1</sub>a:C<sub>2</sub>iC<sub>3</sub>/

(376)            /ʔ<sub>1</sub>a:l<sub>2</sub>i<sub>m</sub><sub>3</sub>/, ‘scholar/scientist’            /ʔ<sub>1</sub>u<sub>l</sub><sub>2</sub>a<sub>m</sub><sub>3</sub>a:ʔ<sub>4</sub>/  
                   /ʃ<sub>1</sub>a:ʔ<sub>2</sub>i<sub>r</sub><sub>3</sub>/, ‘poet’                                /ʃ<sub>1</sub>uʔ<sub>2</sub>a<sub>r</sub><sub>3</sub>a:ʔ<sub>4</sub>/

b. /C<sub>1</sub>aC<sub>2</sub>i:C<sub>3</sub>/

(377)            /ħ<sub>1</sub>a<sub>k</sub><sub>2</sub>i:m<sub>3</sub>/, ‘wiseman’                                /ħ<sub>1</sub>u<sub>k</sub><sub>2</sub>a<sub>m</sub><sub>3</sub>a:ʔ<sub>4</sub>/  
                   /ʃ<sub>1</sub>a<sub>f</sub><sub>2</sub>i:r<sub>3</sub>/, ‘ambassador’                                /ʃ<sub>1</sub>u<sub>f</sub><sub>2</sub>a<sub>r</sub><sub>3</sub>a:ʔ<sub>4</sub>/

The epenthetic glottal stop is inserted to avoid long vowel shortening in the final position. Other forms of BP which are closely related to the form under discussion, such as /ʔ<sub>4</sub>aʔ<sub>1</sub>n<sub>2</sub>i<sub>j</sub><sub>3</sub>a:ʔ<sub>5</sub>/ and /ʔ<sub>4</sub>aʃ<sub>1</sub>d<sub>2</sub>i<sub>q</sub><sub>3</sub>a:ʔ<sub>5</sub>/, show that the second vowel is [i]. The quality of this vowel suggests that it is epenthetic because the epenthetic vowel in general is [i] (Abumdas, 1985, 206; Kager, 1999, 125). However, the question raised is why the second vowel in /ʔ<sub>1</sub>u<sub>l</sub><sub>2</sub>a<sub>m</sub><sub>3</sub>a:ʔ<sub>4</sub>/ is [a] and not [i]. Based on the horizontal classification of vowels, they can be classified as front, central and back. However, the distribution of the main Arabic vowels [i], [a], and [u] if are considered based on this horizontal scale, we find that [i] is front, [u] is back but [a] is not central. If the position of [a] is considered in relation to the contrasted front and back vowels, it is obvious that it is closer to the back vowel and further from the front. Now, some possible occurrence of consecutive vowels can be established. There is no restriction on the occurrence of homogenous vowels. The occurrence of [a] + [u] and [a] + [i] in any order is permitted since each pair is combined from a neighbouring combination. Nevertheless, the occurrence of front plus back is very restricted (Bakkuush, 1987, 51-52). The order [i] + [u] does not exist, but [u] + [i] is restricted to the morphology of the passiveness of verbs.

### 7.3.7 Form /C<sub>4</sub>aC<sub>1</sub>C<sub>2</sub>iC<sub>3</sub>a:C<sub>5</sub>/

This BP is applicable to singular VNs of the form /C<sub>1</sub>aC<sub>2</sub>i:C<sub>3</sub>/ which has the glide /j/ in C<sub>3</sub>. Structurally, there is a similarity between this BP form and the preceding one. The only difference is the syllabification of the first syllable and the quality of the vowel of the second syllable which seems to be coloured by the neighbouring high front vowel. The glottal stop initially suggests that the first syllable is at the underlying level a light syllable which contains a low vowel. Deleting the unstressed low vowel motivates the insertion of the glottal stop to prevent the initial consonant cluster, for example:

a. /C<sub>1</sub>aC<sub>2</sub>i: /

- |       |  |  |
|-------|--|--|
| (378) | /ʔ <sub>1</sub> ɑn <sub>2</sub> i:/, 'rich'    | /ʔ <sub>4</sub> ɑʔ <sub>1</sub> n <sub>2</sub> i.j <sub>3</sub> a:ʔ <sub>5</sub> / |
|       | /n <sub>1</sub> ab <sub>2</sub> i:/, 'prophet' | /ʔ <sub>4</sub> an <sub>1</sub> b <sub>2</sub> i.j <sub>3</sub> a:ʔ <sub>5</sub> / |

The morphological process of forming this BP form gives an insight into the importance of the root consonants. If the consonantal features of the glide are not identified, the BP morpheme will fail to identify the active morphological site which is the host of this morpheme. Consider the underlying structural form of the BP /ʔ<sub>4</sub>ɑʔ<sub>1</sub>n<sub>2</sub>i.j<sub>3</sub>a:ʔ<sub>5</sub>/. The morphology requires the location of the BP morpheme after C<sub>3</sub>, yielding the structure √ʔ<sub>1</sub>n<sub>2</sub>j<sub>3</sub>a:/. For the syllabification process, the third syllable is already formed and it is well structured by the fact that the BP morpheme constructs a heavy syllable in which C<sub>3</sub> is taken as its onset. C<sub>1</sub> and C<sub>2</sub> are each syllabified as a light syllable by inserting the default vowel /a/ in each empty vowel position, giving the structure /ʔ<sub>1</sub>an<sub>2</sub>a.j<sub>3</sub>a:/. Recall that the underlying syllabification process of root consonants is based on the assumption that the underlying syllable structure of Arabic is an open light syllable (Lowenstamm Lecarme, 1996; Guerssel and Lowenstamm, 1996; Idrissi, 1997). Thus, the existence of closed syllables at the surface is due to phonological or morphological constraints which, for example, require the deletion of unstressed short low vowels or the deletion of an unidentified segment as a result of a morphological process. In other words, the phonology identifies the root consonants of a morphological process as onsets of light open



filled the active morphological site. The positions of the two morphemes are identified in the same position, which is after the second root consonant. The restriction on filling an active morphological site by only one morpheme in a derivational process, however, causes the BP morpheme /a:/ to overwrite the transferred long vowel. Arabic grammarians always associate this BP form as the noun plural of the singular form /CvCvvC/ with or without a feminine singulative suffix /-t/. Such singular forms, which are classified as adjectives, take the adjectival BP form /CiCa:C/. This suggests that the grammatical classification plays a role in deciding the number of syllables in the BP form. Let us first consider as examples an adjective and a noun which have the long /i:/ in their second syllable:

(381)	Singular Form	BP Form
	/k <sub>1</sub> ab <sub>2</sub> i:r <sub>3</sub> / ‘big’ (adjective)	/k <sub>1</sub> b <sub>2</sub> a:r <sub>3</sub> /
	/q <sub>1</sub> ab <sub>2</sub> i:l <sub>3</sub> -at/ ‘tribe’ (noun)	/q <sub>1</sub> ab <sub>2</sub> a:ʔ <sub>4</sub> il <sub>3</sub> / ‘tribes’

In /k<sub>1</sub>ab<sub>2</sub>i:r<sub>3</sub>/, the long vowel /i:/ is an adjectival morpheme, while in /qabi:l-at/ it is a part of the noun. The underlying structure of the morphological derivational process for deriving the adjective consists of the root consonants plus the adjectival morpheme √kbr + /i:/, which yields the structure √kbi:r. Deriving the BP for this adjective gives the underlying structure √kbi:r + /a:/, in which the BP morpheme clashes with the adjective morpheme since the two morphological processes identify the same active morphological site after C<sub>2</sub> by. Thus, /i:/ is deleted in favour of the BP morpheme. By comparison, the long vowel /i:/ of the noun is also not carried over to the BP form, but the motivation for this deletion is different from that of the adjective. The BP form /C<sub>1</sub>aC<sub>2</sub>a:C<sub>4</sub>iC<sub>3</sub>/ is a noun form and it is only applicable to singular nouns. The corresponding noun form for the adjective /k<sub>1</sub>ab<sub>2</sub>i:r<sub>3</sub>/ is /k<sub>1</sub>ab<sub>2</sub>i:r<sub>3</sub>-at/, ‘sin’. This noun form now qualifies for the BP /C<sub>1</sub>aC<sub>2</sub>a:C<sub>4</sub>iC<sub>3</sub>/, giving /k<sub>1</sub>ab<sub>2</sub>a:j<sub>4</sub>ir<sub>3</sub>/, ‘sins’. From a structural point of view, the only difference between the adjective and the noun is the suffix /t/ which marks the noun of one instance. Moreover, the noun does not necessarily need to have this suffix to qualify for this BP. In all the follow examples associated with this BP form whether

or not it has /t/, the noun takes this BP form. Interestingly, the long vowel /i:/ of the noun form corresponds to the glottal stop /ʔ/ in CA and corresponds to /j/ in the follow examples from LA. It seems, however, that the length of the long vowel of the noun motivates the appearance of the glide in the output BP form. Bear in mind that the vocalic features of the glide of the input noun cannot surface, because they are preceded by the BP morpheme /a:/. Consequently, the vocalic features of the glide could either be deleted or forced to surface with their consonantal features. However, deletion means that the noun loses some of its root components. The only way to keep the faithfulness relation of correspondence between the noun and its corresponding derived BP is to preserve the consonantal features of the glide. In this way, the vocalic features of the glide do not clash with the BP morpheme, and also the surface consonantal features of the glide stand in a relation of faithfulness to the vocalic features of the glide in the input noun. However, the actual surface of the glide in the BP form is as a glottal stop in CA, and as a glide /j/ in LA.

It seems that there are some restrictions on the surfacing of high glides which result from a derivational morphological process. Brame (1970, 23-24) noticed that the medial high glides do not show up in the derivation of the active participle. They rather surface as a glottal stop forced by a phonological rule she called the ‘Glottal Formation Rule’. Consider the following examples of the root consonants and their corresponding derived active participles:

- (382)            √kwn, ‘to make’            /ka:ʔin/ ‘existent’  
                   √sjr, ‘to run’            /sa:ʔir/ ‘walker’

Both high glides surface as glottal stops /ʔ/. But, when the medial root is not a glide, the medial root consonant surfaces as normal, for example:

- (383)            √ktb, ‘to write’            /ka:tib/ ‘writer’

Thus, the glottal stop is not an epenthetic consonant compensating for the deletion of a glide or filling an empty onset. It turns out that the glottal stop is the actual



realization of the high glides in a derivational morphological process. As we have already come across many examples, in a phonological process the glide is forced to surface with its vocalic or consonantal features, and this is motivated by purely phonological constraints. To account for the surface glottal stop as a compensation for the high glides in the active participle form and the BP form, we need to assume that the motivation for this glide change is a morpho-phonological process. In other words, it is restricted to some morphological processes where the root components of the input consist of either a glide or a long vowel and where the glide has to surface as a glottal stop. Let us now consider the singular noun forms that qualify for this BP form, for example:

a. /C<sub>1</sub>aC<sub>2</sub>i:C<sub>3</sub>/

(384)            /f<sub>1</sub>a s<sup>ʕ</sup><sub>2</sub> i:l<sub>3</sub>/, ‘faction’                            /f<sub>1</sub>a s<sup>ʕ</sup><sub>2</sub> α:j<sub>4</sub> i l<sub>3</sub>/  
                      /d<sup>ʕ</sup><sub>1</sub> α m<sub>2</sub> i:r<sub>3</sub>/, ‘conscience’                            /d<sup>ʕ</sup><sub>1</sub> α m<sub>2</sub> α:j<sub>4</sub> i r<sub>3</sub>/

In CA, the BP surfaces with the glottal stop as, for instance, /f<sub>1</sub>a s<sup>ʕ</sup><sub>2</sub> α:ʔ<sub>4</sub> i l<sub>3</sub>/ . This BP is derived as presented in the follow tableau. For the sake of explanation and simplicity, we use the consonantal features of the glide are used in the input and not as a long vowel which appears in the singular noun:

(385)

Input: [f s <sup>ʕ</sup> â : j l]	GLIDE=ONSET	GLIDE ⇒ [ʔ]	IDENT	MAX
a. → /f <sub>1</sub> a.s <sup>ʕ</sup> <sub>2</sub> α:.ʔ <sub>3</sub> i l <sub>4</sub> /			*	
b. /f <sub>1</sub> a.s <sup>ʕ</sup> <sub>2</sub> α:.j <sub>3</sub> i l <sub>4</sub> /		*!		
c. /f <sub>1</sub> a.s <sup>ʕ</sup> <sub>2</sub> α:.i:l <sub>4</sub> /	*!	*		

In the sequence of subscript numbers, the ordered root segments suggest that this noun is actually in quadrilateral and not trilateral form because of the fact that the long vowel which appears in the singular noun is underlyingly a glide and part of the root components of the input. In all the possible candidates, the underlying glide corresponds to some elements in the output. In (c), it corresponds to the vocalic features, while in (b) it corresponds to the consonantal features of the glide. However, the glottal stop in candidate (a) stands in an unfaithful relation to the glide. There are

two requirements for the glide to surface in the output suggested by the optimal output candidate (a). They are, firstly, that the glide must surface with its consonantal features, so that it does not create a string of four moras with the BP morpheme; and secondly, the glide has to change into a glottal stop. Thus, the glide in candidate (c) surfaces with its vocalic features in violation of the top ranked constraint. Candidate (b) violates the second top ranked constraint which requires the glide to change to a glottal stop. Because identity faithfulness is ranked lower than the top two constraints, candidate (a) wins. It must be noted that there is no violation of the MAX constraint, since each output has a corresponding segment to each in the input.

In the LA optimal candidate /f<sub>1</sub>a s<sup>2</sup>α: j<sub>4</sub>i l<sub>3</sub>/, the glide does not correspond to the glide of the input in a faithfulness relation. Actually, the glide is the actual surface of the glottal stop, since LA tends to replace the glottal stop with a glide /j/ whether the actual underlying glide is /w/ or /j/. Thus, the input for LA is in fact the optimal candidate of CA, as represented in the tableau below:

(386)

Input: /f <sub>1</sub> a s <sup>2</sup> â: ʔ <sub>3</sub> i l <sub>4</sub> /	*[ʔ]	IDENT	MAX
a. →/f <sub>1</sub> a.s <sup>2</sup> α: .j <sub>3</sub> i l <sub>4</sub> /		*	
b. /f <sub>1</sub> a.s <sup>2</sup> α: .ʔ <sub>4</sub> i l <sub>3</sub> /	*!		

As can be seen from the tableau, candidate (b) loses because the constraint which militates against the glottal stop is ranked higher than the identity constraint. With both candidates, there is no violation of the MAX constraint since the two have corresponding segments.

b. /C<sub>1</sub>aC<sub>2</sub>i:C<sub>3</sub>-at/

(387)            /ʒ<sub>1</sub>ar<sub>2</sub>i:d<sub>3</sub>-at/, ‘newspaper’            /ʒ<sub>1</sub>ar<sub>2</sub>a:j<sub>4</sub>id<sub>3</sub>/  
                      /d<sub>1</sub>ag<sub>2</sub>i:g<sub>3</sub>-at/, ‘minute’            /d<sub>1</sub>ag<sub>2</sub>a:j<sub>4</sub>ig<sub>3</sub>/

The derivation of these two nouns follows the same derivation of the preceding nouns but, as is always the case suffixations do not contribute to the derivational morphological process of BP. In these singular nouns, the suffix /t/ is deleted because

it designates the singular number in the noun and thus it does not have any role in the formation of the plural.

c. /C<sub>4</sub>iC<sub>1</sub>C<sub>2</sub>a:C<sub>3</sub>-at/

(388)            /ʔ<sub>4</sub>iʃ<sub>1</sub>k<sub>2</sub>ɑ:r<sub>3</sub>-ɑt/, ‘sack’                            /ʃ<sub>1</sub>ak<sub>2</sub>a:j<sub>5</sub>ir<sub>3</sub>/  
                   /ʔ<sub>4</sub>iʔ<sub>1</sub>m<sub>2</sub>a:m<sub>3</sub>-at/, ‘turban’                        /ʔ<sub>1</sub>am<sub>2</sub>a:j<sub>5</sub>im<sub>3</sub>/

These singular forms are very interesting in the way their long vowel /a: / behaves in the BP forms. The root component /a: / is treated in a way similar to the way the glides are treated in the derivation of the active participle mentioned earlier. In fact, this long vowel surfaces as a glottal stop in the output BP form. Then, the constraint militates against the surfacing of the glottal stop in LA, forcing it to surface as a glide /j/.

### 7.3.9 Form /C<sub>1</sub>aC<sub>2</sub>a:C<sub>3</sub>i: /

All the singular forms that qualify for this BP form end in the long vowel /a: /. This long vowel denotes the singular feminine gender which is suffixed to nonhuman nouns (Sibawayh, 1999, Vol. VI, 84-85; Al-Hadithi, 2003, 209). Interestingly, this suffix is not truncated in the derivation of BP, as is usually the case for other feminine suffixes. The length of the long vowel is preserved in the BP form, but its quality is changed to front features so as to be compatible with the requirement of BP formation to front the features of the transferred final long vowels. The length of the final long vowel of the BP form suggests that its corresponding long vowel in the singular form is genuine and part of the root components; otherwise the length of the final vowel of the BP form could not be obviously motivated. It must be noted that the feminine marker usually surfaces as /t/ in connected speech, but in a pause the marker surfaces as a long vowel /a: /. Thus, the singular candidates are nouns ending in a feminine marker. This is very important, since the BP form /CaCa:Ca: / is applicable only to adjectives whose marker is carried over from the singular form to the BP form, seen





b. /C<sub>1</sub>aC<sub>2</sub>C<sub>3</sub>a:C<sub>4</sub>/

- (395) /s<sub>1</sub>ak<sub>2</sub>r<sub>3</sub>a:n<sub>4</sub>/, 'drunk' /s<sub>1</sub>ak<sub>2</sub>a:r<sub>3</sub>a:/  
/s<sub>1</sub>ah<sub>2</sub>r<sub>3</sub>a:n<sub>4</sub>/, 'awake at night' /s<sub>1</sub>ah<sub>2</sub>a:r<sub>3</sub>a:/

c. /C<sub>1</sub>aC<sub>2</sub>C<sub>3</sub>a:C<sub>4</sub>/

- (396) /ʔ<sub>1</sub>að<sub>2</sub>r<sub>3</sub>a:ʔ<sub>4</sub>/, 'virgin' /ʔ<sub>1</sub>að<sub>2</sub>a:r<sub>3</sub>a:/  
/s<sup>ʔ</sup><sub>1</sub>ah<sub>2</sub>r<sub>3</sub>a:ʔ<sub>4</sub>/, 'desert' /s<sup>ʔ</sup><sub>1</sub>ah<sub>2</sub>a:r<sub>3</sub>a:/

d. /C<sub>1</sub>aC<sub>2</sub>i:C<sub>3</sub>/

- (397) /j<sub>1</sub>at<sub>2</sub>i:m<sub>3</sub>/, 'orphan' /j<sub>1</sub>at<sub>2</sub>a:m<sub>3</sub>a:/  
/ħ<sub>1</sub>az<sub>2</sub>i:n<sub>3</sub>/, 'sad' /ħ<sub>1</sub>az<sub>2</sub>a:n<sub>3</sub>a:/

e. /C<sub>1</sub>aC<sub>2</sub>i:C<sub>3</sub>-at/

- (398) /s<sub>1</sub>aʒ<sub>2</sub>i:j<sub>3</sub>-at/, 'virtue' /s<sub>1</sub>aʒ<sub>2</sub>a:j<sub>3</sub>a:/  
/h<sub>1</sub>ad<sub>2</sub>i:j<sub>3</sub>-at/, 'gift' /h<sub>1</sub>ad<sub>2</sub>a:j<sub>3</sub>a:/

f. /C<sub>1</sub>a:C<sub>2</sub>iC<sub>3</sub>-at/

- (399) /z<sub>1</sub>a:w<sub>2</sub>ij<sub>3</sub>-at/, 'angle/corner' /z<sub>1</sub>aw<sub>2</sub>a:j<sub>3</sub>a:/

g. /C<sub>1</sub>aC<sub>2</sub>u:C<sub>3</sub>/

- (400) /k<sub>1</sub>as<sub>2</sub>u:l<sub>3</sub>/, 'lazy' /k<sub>1</sub>as<sub>2</sub>a:l<sub>3</sub>a:/  
/ʒ<sub>1</sub>as<sub>2</sub>u:r<sub>3</sub>/, 'brave' /ʒ<sub>1</sub>as<sub>2</sub>a:r<sub>3</sub>a:/

In all these examples, the underlined adjectival markers are transferred to the BP form. Regardless of the position of these markers in the input singular, they appear as the adjectival vowel suffix /a:/ in the output BP. Thus, the underlying structure of the BP form should include the adjectival marker of the input since it represents a

morphological operation which becomes a part of the underlying form which must be preserved in the morphological derivational process of BP. That means that, for example, the BP form /s<sub>1</sub>ak<sub>2</sub>a:r<sub>3</sub>a:/ has the underlying structure √skra:n + /a:n/, which includes the root consonants plus the adjectival marker /a:n/, and in the formation of BP the underlying structure after infixing the BP morpheme gives √ska:ra:n. The underlying structure of this BP consists of two grammatical morphemes that distinguish the adjective: that is, /a:n/ transferred from the singular and /a:/ supplied with the BP form. This cannot be acceptable since it marks the adjectival category with two morphemes at the same time within one word. Thus, the constraint \*DOUBLE-MARKING can be suggested which has a lexical function and its main function is to militate against a grammatical category to be assigned appearing more than once:

(401)

Input: [skâ:râ:ñ]	*DOUBLE-MARKING	MAX
a. → /s <sub>1</sub> a.k <sub>2</sub> a:r <sub>3</sub> a:/		*
b. /s <sub>1</sub> a.k <sub>2</sub> a:r <sub>3</sub> a:n <sub>4</sub> /	*!	

Highly ranking the constraint \*DOUBLE-MARKING over the faithfulness constraint MAX allows for the deletion of the extra morpheme. This deletion is motivated by the morphological derivational process, because the deleted morpheme is from the input and not supplied by the output. It seems that the derivational process of BP has an effect on shifting the adjectival morpheme from any position within the stem to the right margin of the stem where it is considered as a suffix. The following example shows the internal position of the adjectival morpheme of the active participle:

(402)

Input: [zâ:wâ:jâ:]	*DOUBLE-MARKING	MAX
a. → /z <sub>1</sub> a.w <sub>2</sub> a:j <sub>3</sub> a:/		*
b. /z <sub>1</sub> a:w <sub>2</sub> a:j <sub>3</sub> a:/	*!	

As candidate (b) shows, the internal adjectival morpheme has to shift to the right edge of the derived BP word. It must be noted that adjectival BP forms always gain their grammatical category from their corresponding inputs. However, if the input adjective

establishes and qualifies for a BP noun form, especially when the adjective acquires a noun state, the adjectival morpheme is no longer needed since the grammatical category is changed.

### 7.3.11 Form /C<sub>1</sub>aC<sub>2</sub>C<sub>3</sub>a:/

This form is a verbal adjective which denotes injuries and defects of the body or mind (Wright, 2005, Vol. I, 220). In many cases, it has been observed that adjectives sometimes assign the BP morpheme after C<sub>3</sub>, as in /ʔ<sub>1</sub>aŋ<sub>2</sub>i:/ ⇒ /ʔ<sub>4</sub>aʔ<sub>1</sub>n<sub>2</sub>j<sub>3</sub>a:ʔ<sub>5</sub>/ and /ʔ<sub>1</sub>a:q<sub>2</sub>i:l<sub>3</sub>/ ⇒ /ʔ<sub>1</sub>uq<sub>2</sub>a:l<sub>3</sub>a:ʔ<sub>4</sub>/. Similarly, this adjectival BP form is distinguished by two morphological processes: the BP morpheme marks the plural, and the position of the same morpheme marks the adjectival category. As can be seen from the singular forms below, the adjectival morpheme of the singular form /i:/ is not carried over to the adjectival BP, but rather the position of the BP morpheme functions as a plural marker as well as an adjectival marker.

#### a. /C<sub>1</sub>aC<sub>2</sub>i:C<sub>3</sub>/

Only singular nouns of this form that denote a passive meaning qualify for this form of BP, for example:

- |       |  |  |
|-------|--|--|
| (403) | /ʒ <sub>1</sub> a r <sub>2</sub> i : ħ <sub>3</sub> /, ‘injured’ | /ʒ <sub>1</sub> a r <sub>2</sub> ħ <sub>3</sub> a :/ |
|       | /g <sub>1</sub> a t <sub>2</sub> i : l <sub>3</sub> /, ‘dead’    | /g <sub>1</sub> a t <sub>2</sub> l <sub>3</sub> a :/ |

#### b. /ʔ<sub>4</sub>aC<sub>1</sub>C<sub>2</sub>aC<sub>3</sub>/

Singular forms denote adjectives of physical defect qualifying for this BP, for example:

- |       |   |   |
|-------|---|---|
| (404) | /ʔ <sub>4</sub> a x <sub>1</sub> r <sub>2</sub> a s <sub>3</sub> /, ‘dumb’              | /x <sub>1</sub> a r <sub>2</sub> s <sub>3</sub> a :/              |
|       | /ʔ <sub>4</sub> a t <sup>ʔ</sup> <sub>1</sub> r <sub>2</sub> a ʃ <sub>3</sub> /, ‘deaf’ | /t <sup>ʔ</sup> <sub>1</sub> a r <sub>2</sub> ʃ <sub>3</sub> a :/ |





b. /C<sub>1</sub>u:C<sub>2</sub>a:C<sub>3</sub>/

(407) /d<sub>1</sub>u:l<sub>2</sub>a:b<sub>3</sub>/, ‘cupboard’ /d<sub>1</sub>aw<sub>4</sub>a:l<sub>2</sub>i:b<sub>3</sub>/

c. /C<sub>1</sub>a:C<sub>2</sub>u:C<sub>3</sub>-at/

(408) /f<sub>1</sub>a:t<sub>2</sub>u:r<sub>3</sub>-at/, ‘bill’ /f<sub>1</sub>aw<sub>4</sub>a:t<sub>2</sub>i:r<sub>3</sub>/  
 /m<sub>1</sub>a:s<sub>2</sub>u:r<sub>3</sub>-at/, ‘pipe’ /m<sub>1</sub>aw<sub>4</sub>a:s<sub>2</sub>i:r<sub>3</sub>/

It must be said here that all the singular forms which have three root consonants on the surface of the singular forms and which qualify for the BP to form C<sub>1</sub>aC<sub>4</sub>a:C<sub>2</sub>i:C<sub>3</sub> are not derived words. The order of the subscript numbers neither reflects nor suggests any derivational process, but rather only reflects the order of the segments as they appear in the two corresponding forms. The realization of the first long vowel of the singular as a glide /w/ triggered by the requirement of the BP morpheme to realize the second root consonant gives a strong argument that long vowels are at the underlying level represented as glides. If the BP morpheme fails to identify the active morphological site of the underlying glide, it may be misplaced. In fact, all these singular forms should be treated as quinqueliteral root consonants because these singulars consist of three surfaced consonants plus two underlying glides which surface as vocalic or consonantal segments. In the tableau below, the derivation of /t<sup>ɛ</sup><sub>1</sub>aw<sub>4</sub>a:b<sub>2</sub>i:r<sub>3</sub>/ is taken as an illustrative example. This BP form has the underlying structure [√t<sup>ɛ</sup>wbwr, /a:/] where both underlying glides are represented as [w]:

(409)

Input: [t <sup>ɛ</sup> wâ:bwr]	*5 <sub>CONSONANTS</sub>	MAX-C	IDENT
a. →/ t <sup>ɛ</sup> <sub>1</sub> a.w <sub>2</sub> a:b <sub>3</sub> i:r <sub>5</sub> /		*	*
b. / t <sup>ɛ</sup> <sub>1</sub> a.w <sub>2</sub> a:b <sub>3</sub> u:r <sub>5</sub> /		*	
c. / t <sup>ɛ</sup> <sub>1</sub> a.w <sub>2</sub> a:b <sub>3</sub> w <sub>4</sub> r <sub>5</sub> /	*!		

The possible candidates show that the BP morpheme is hosted in the active morphological site which is headed by the surfaced glide with its consonantal features that are positioned in C<sub>2</sub>. Otherwise, the right position for the BP morpheme will be

misplaced. Thus, the assumption is made that the long vowel is at the underlying level a glide and consequently it is in the position of C<sub>2</sub>. However, the question is why the first glide has to surface with its consonantal features and the second one does not. If the second glide surfaces with its consonantal features, this will create a string of five root consonants, as in candidate (c), which violates the top ranked constraint which militates against any derivational structure exceeding four root consonants. The constraint \*5<sub>CONSONANTS</sub> actually works on the behaviour of other top ranked constraints, which are not included in the tableau for the sake of simplicity. It is not a straightforward process to syllabify five root consonants without creating complex consonant clusters or creating a number of syllables which could exceed the maximum permitted syllables in the language, bearing in mind that the language tends to favour open syllables in many morphologically derived structures. Both candidates (b) and (a) show that, to avoid exceeding the maximum permitted root number, the second glide has to surface with its vocalic features. As a matter of fact, both candidates violate the faithfulness constraint which requires the preservation of the consonantal features of the input. The competition between (b) and (a) is settled by the morphophonological characteristics of the BP, which requires the fronting of the features of the final long vowel. Hence, there is no violation of the identity constraint caused by (c) or (b) because they both preserve the consonantal and vocalic features of the input. Therefore, candidate (a) wins by ranking the identity constraint low.

### **7.3.13 Form /C<sub>1</sub>vC<sub>2</sub>vC<sub>3</sub>/**

The structure of this BP is similar to that of the collective noun with a diversity of short vowels. The second vowel is usually the back low vowel /a/, but the initial vowel is phonologically supplied as /i/. However, in neighbouring guttural segments it is forced to surface as a back vowel. Although the collective noun has many structural forms depending on the corresponding singular input, the morphological process is represented as follows: deleting the suffix singular marker /t/, and then resyllabifying the structure in such a way that consonant clusters are avoided. The sense of similarity between the BP form and the collective noun is expressed by their corresponding input singular forms. The singular form is associated with the suffix /t/, which designates the noun of one instance. This relation could reveal why the BP

has a similar structure to that of the collective noun. Consider some collective examples:

- (410)    /r<sub>1</sub>i : ∫<sub>3</sub>-at/, ‘feather’                      /r<sub>1</sub>i : ∫<sub>3</sub>/  
               /d<sub>1</sub>u : d<sub>3</sub>-at/, ‘worm’                         /d<sub>1</sub>u : d<sub>3</sub>/

The structure of the collective noun is at the underlying level represented as /C<sub>1</sub>aC<sub>2</sub>aC<sub>3</sub>/. The length of the long vowel is the actual realization of the medial glide, since the language has many restrictions on the surfacing of the glide in such positions. For words that do not exhibit medial glides, the derivational process of the collective noun is straightforward. The suffix is deleted and the resulting structure is resyllabified. It must be noted that the underlying structure of these collective nouns is represented as /C<sub>1</sub>aC<sub>2</sub>C<sub>3</sub>/, but because of the preference of the language to avoid consonant clusters, the monosyllabic heavy syllable is restructured as a string of two light syllables:

- (411)    /t<sub>1</sub>am<sub>2</sub>r<sub>3</sub>-at/, ‘date’                                 /t<sub>1</sub>am<sub>2</sub>ar<sub>3</sub>/  
               /g<sub>1</sub>am<sub>2</sub>l<sub>3</sub>-at/, ‘lice’                                    /g<sub>1</sub>am<sub>2</sub>al<sub>3</sub>/

The distinction between the two plurals, the BP and the collective noun, is in fact captured by the quality of the initial and final vowels of the BP form which seem to be supplied morphologically. In the collective noun, the initial vowel is the lexical one and the second is supplied by the phonology. On the other hand, the initial vowel of the BP is phonologically /i/ or a backed vowel due to neighbouring guttural or bilabial sounds, and the second is lexically supplied as /a/. In the examples below it must be said that the BP form is at the underlying level represented as /C<sub>1</sub>vC<sub>2</sub>vC<sub>3</sub>/, but, because LA tends to delete unstressed vowels, the initial vowel is deleted and the resulting initial consonant cluster is avoided by inserting an initial glottal stop and a short vowel, for example:

a. /C<sub>1</sub>o : C<sub>3</sub>-at/

- (412)    /d<sub>1</sub>o : l<sub>3</sub>-at/, ‘country’                                 /ʔ<sub>5</sub>id<sub>1</sub>w<sub>2</sub>al<sub>3</sub>/

/s<sup>ɤ</sup><sub>1</sub>o:r<sub>3</sub>-at/, ‘picture’

/ʔ<sub>5</sub>is<sup>ɤ</sup><sub>1</sub>w<sub>2</sub>ar<sub>3</sub>/

b. /C<sub>1</sub>i:C<sub>3</sub>-at/

(413) /ħ<sub>1</sub>i:l<sub>3</sub>-at/, ‘trick’

/ʔ<sub>4</sub>iħ<sub>1</sub>j<sub>2</sub>al<sub>3</sub>/

/ʃ<sub>1</sub>i:ʃ<sub>2</sub>-at/, ‘bottle/glass’

/ʔ<sub>4</sub>iʃ<sub>1</sub>j<sub>2</sub>aʃ<sub>3</sub>/

c. /C<sub>1</sub>uC<sub>2</sub>C<sub>3</sub>-at/

(414) /g<sub>1</sub>ub<sub>2</sub>b<sub>3</sub>-at/, ‘dome’

/ʔ<sub>4</sub>ag<sub>1</sub>b<sub>2</sub>ab<sub>3</sub>/

/ɣ<sub>1</sub>ur<sub>2</sub>f<sub>3</sub>-at/, ‘room’

/ʔ<sub>4</sub>αɣ<sub>1</sub>r<sub>2</sub>af<sub>3</sub>/

d. /C<sub>1</sub>iC<sub>2</sub>C<sub>3</sub>-at/

(415) /s<sub>1</sub>in<sub>2</sub>n<sub>3</sub>at/, ‘tradition’

/ʔ<sub>4</sub>is<sub>1</sub>n<sub>2</sub>an<sub>3</sub>/

/k<sub>1</sub>is<sub>2</sub>r<sub>3</sub>at/, ‘fraction’

/ʔ<sub>4</sub>ik<sub>1</sub>s<sup>ɤ</sup><sub>2</sub>ar<sub>3</sub>/

e. /C<sub>1</sub>iC<sub>2</sub>C<sub>3</sub>-at/

(416) /q<sub>1</sub>it<sup>ɤ</sup><sub>2</sub>ʔ<sub>3</sub>-at/, ‘a piece’

/q<sub>1</sub>it<sup>ɤ</sup><sub>2</sub>aʔ<sub>3</sub>/

/ħ<sub>1</sub>ik<sub>2</sub>m<sub>3</sub>-at/, ‘a wisdom’

/ħ<sub>1</sub>ik<sub>2</sub>am<sub>3</sub>/

f. /C<sub>1</sub>aC<sub>2</sub>C<sub>3</sub>-at/

(417) /x<sub>1</sub>e:~<sub>2</sub>m<sub>3</sub>-at/, ‘tent’

/ʔix<sub>1</sub>j<sub>2</sub>am<sub>3</sub>/

/q<sub>1</sub>e:~<sub>2</sub>m<sub>3</sub>-at/, ‘value’

/q<sub>1</sub>ij<sub>2</sub>am<sub>3</sub>/

g. /C<sub>1</sub>uC<sub>2</sub>C<sub>3</sub>-at/

(418) /t<sub>1</sub>uħ<sub>2</sub>f<sub>3</sub>-at/, ‘souvenir’

/t<sub>1</sub>uħ<sub>2</sub>af<sub>3</sub>/

/ʔ<sub>1</sub>um<sub>2</sub>m<sub>3</sub>-at/, ‘nation’

/ʔ<sub>1</sub>um<sub>2</sub>am<sub>3</sub>/

h. /C<sub>1</sub>aC<sub>2</sub>C<sub>3</sub>-at/

- (419)      /d<sub>1</sub>aw<sub>2</sub>l<sub>3</sub>-at/, ‘country’                      /d<sub>1</sub>uw<sub>2</sub>a<sub>1</sub>l<sub>3</sub>/  
               /q<sub>1</sub>ar<sub>2</sub>j<sub>3</sub>-at/, ‘village’                         /q<sub>1</sub>ur<sub>2</sub>a: /

Although this BP is distinguished from the collective noun by the lexical vowels, the close relation between the meaning of this BP and that of the collective noun must not be disregarded. The corresponding singulars which are suffixed with the morpheme which designates the noun of one instance singular, and each of these two plurals bring the sense of the collective noun in the plural forms. Thus, this BP should be considered as a collective noun which refers to the individuals as one group.

### 7.3.14 Form /C<sub>1</sub>uC<sub>2</sub>C<sub>3</sub>/ ⇒ /C<sub>1</sub>uC<sub>2</sub>uC<sub>3</sub>/

This BP form /C<sub>1</sub>uC<sub>2</sub>C<sub>3</sub>/ is an adjectival form and it is restricted to adjectives which denote colours and physical and mental defects. The underlying structure of this form is represented as a monosyllabic superheavy syllable, but in the surface structure LA tends to break the complex coda by an epenthetic vowel which is in harmony with the initial lexical vowel. This lexical vowel is the BP morpheme, for example:

a. /C<sub>1</sub>aC<sub>2</sub>C<sub>3</sub>a: /

- (420)      /h<sub>1</sub>am<sub>2</sub>r<sub>3</sub>a: /, ‘red’                                      /h<sub>1</sub>um<sub>2</sub>ur<sub>3</sub>/  
               /s<sup>ɛ</sup><sub>1</sub>af<sub>2</sub>r<sub>3</sub>a: /, ‘yellow’                                      /s<sup>ɛ</sup><sub>1</sub>uf<sub>2</sub>ur<sub>3</sub>/

b. /C<sub>4</sub>aC<sub>1</sub>C<sub>2</sub>aC<sub>3</sub>/

- (421)      /ʔ<sub>4</sub>αʔ<sub>1</sub>r<sub>2</sub>αʔ<sub>3</sub>/, ‘cripple’                                      /ʔ<sub>1</sub>ur<sub>2</sub>uʔ<sub>3</sub>/  
               /ʔ<sub>4</sub>αz<sub>1</sub>r<sub>2</sub>αg<sub>3</sub>/, ‘blue’    /z<sub>1</sub>ur<sub>2</sub>ug<sub>3</sub>/

c. /C<sub>1</sub>aC<sub>2</sub>i: C<sub>3</sub>/

- (422)      /ʔ<sub>1</sub>ag<sub>2</sub>i: m<sub>3</sub>/, ‘sterile’                                      /ʔ<sub>4</sub>uʔ<sub>1</sub>g<sub>2</sub>um<sub>3</sub>/

/s<sub>1</sub>a<sub>g</sub><sub>2</sub>i : m<sub>3</sub>/, ‘ill’

/ʔ<sub>4</sub>u<sub>s</sub><sub>1</sub>g<sub>2</sub>u<sub>m</sub><sub>3</sub>/

d. /ʔ<sub>4</sub>a<sub>C</sub><sub>1</sub>C<sub>2</sub>a<sub>C</sub><sub>3</sub>/

(423) /ʔ<sub>4</sub>a<sub>b</sub><sub>1</sub>j<sub>2</sub>a<sub>d</sub><sub>3</sub>/, ‘white’

/b<sub>1</sub>i : d<sub>3</sub>/

/ʔ<sub>4</sub>a<sub>s</sub><sub>1</sub>w<sub>2</sub>a<sub>d</sub><sub>3</sub>/, ‘black’

/s<sub>1</sub>u : d<sub>3</sub>/

/ʔ<sub>4</sub>a<sub>ʔ</sub><sub>1</sub>m<sub>2</sub>a : /, ‘blind’

/ʔ<sub>1</sub>i<sub>m</sub><sub>2</sub>i/

The examples above show diversity in syllabification. On the one hand, there is a tendency to avoid the underlying superheavy monosyllabic by syllabifying the output in a string of two light syllables. There is also a tendency to restructure these light strings by resyllabifying the initial light syllable into a heavy closed syllable. The deletion of the initial vowel should not be related only to the preference for deleting unstressed short vowels; otherwise this diversity in syllabification cannot be justified. The preference for deleting such vowels might be related to the sonority of the neighbouring consonants, but this matter is not investigated in this study. On the other hand, the underlying monosyllabic structure is preserved in cases where the medial root consonant is a glide. However, the identity of the lexical vowel which marks the BP is not maintained, as in /b<sub>1</sub>i : d<sub>3</sub>/ and /ʔ<sub>1</sub>i<sub>m</sub><sub>2</sub>i/. The loss of identity is phonologically governed, since the lexical vowel /u/ is subject to the effects of a neighbouring vowel either within the same nucleus or within the same foot. In the case of /b<sub>1</sub>i : d<sub>3</sub>/, the underlying structure of this word is /b<sub>1</sub>u<sub>j</sub>d<sub>3</sub>/. The existence of the vowel next to the glide /j/, either with its consonantal or vocalic features, is not permitted in the language. The actual output shows that the vocalic features of the glide spreads to the preceding vowel by a compensatory lengthening process. Consider the following tableau:

(424)

Input: [b <sub>1</sub> u <sub>j</sub> d <sub>3</sub> ]	*[uj]	IDENT-C	IDENT-V
a. → /b <sub>1</sub> i : d <sub>3</sub> /			*
b. /b <sub>1</sub> u : d <sub>3</sub> /		*!	
c. /b <sub>1</sub> u <sub>j</sub> d <sub>3</sub> /	*!		

In a straightforward way, the markedness constraint rules out candidate (c) although it is faithful to the underlying form. Candidate (b) preserves the lexical vowel but it sacrifices the identity of the underlying root consonant which is the glide. This choice is not possible since faithfulness to the root consonant outranks faithfulness to the lexical vowel. Consequently, candidate (a) wins because it preserves the identity of the glide as vocalic and only minimally violates the identity of the lexical vowel. Since the identity of the lexical vowel is ranked low, satisfying the identity of the root consonant plus satisfying the markedness constraint qualifies candidate (a) to be optimal.

The loss of the features of the lexical vowel in /ŋ<sub>1</sub>i<sub>m</sub>₂i/ seems to be constrained by the vocalic features of the glide. In such a position, the underlying glide has to surface as vocalic. The raising of the back lexical vowel is not related to the fact that LA tends to raise the back vowel /u/. This is simply not the case, because the lexical vowel is maintained in most of the examples. The lack of identity is in fact related to the coexistence of the lexical back vowel with the vocalic features of the glide, which is /i/ within the same foot. Such coexistence leads to disharmony between the two vowels. Consider the following example:

(425)

Input: [ŋ <sub>1</sub> û <sub>m</sub> ₂j <sub>3</sub> ]	*GLIDE] <sub>STEM</sub>	HARMONY	IDENT-V	MAX
a. → /ŋ <sub>1</sub> i <sub>m</sub> ₂i/			*	
b. /ŋ <sub>1</sub> u <sub>m</sub> ₂i/		*!		
c. /ŋ <sub>1</sub> u <sub>m</sub> ₂j <sub>3</sub> /	*!	*		

The tableau shows that all the maximum segments are preserved in the candidate outputs. However, there is a restriction on the surfacing of the glide with its consonantal features in the final position. Thus, the glide has to surface but with its vocalic features, otherwise the maximality constraint will be violated. Candidate (c) is ruled out for having a glide at the end. With candidate (b), the vocalic features of the glide are in disharmony with the lexical vowel, so it is ruled out by the second markedness constraint. Now, the price is the loss of the features of the lexical vowel. This should not cause a problem as long as maximality is maintained and as long as only the features of the lexical vowel are ranked low.



## 7.4 Quadriliteral Root Consonants

The four consonants of quadriliteral BP forms are derived from either trilateral or genuine quadriliteral root forms. In forms derived from trilateral forms, whether they are prefixes or infixes (the latter usually being the case), the additional consonant morphemes are considered as genuine root consonants in the sense that they are recognized by the morphological processes. For instance, if the BP identifies  $C_2$  as the host for the BP morpheme and the first consonant was originally a prefix, the morphological process will identify that prefix as the first root consonant. It must be noted that identical medial consonants are not necessarily the result of intensifying the medial consonants of a trilateral form. Such identical consonants are root consonants of a quadriliteral form which do not have correspondence with a trilateral form, and consequently cannot be and are not derived from trilateral forms. In addition, the local and the long consonant spreading are guaranteed by OCP which militates against the adjacency of identical segments. In quadriliteral forms the formation of BP is straightforward, identifying  $C_2$  as the host for the morphological process.

### 7.4.1 Form $/C_1aC_2a:C_3i:C_4/$

The underlying structure of this BP form has a string of root consonants plus the long vowel  $/a:/$  which is positioned between  $C_3$  and  $C_4$ . This long vowel is at the underlying level represented as a glide. However, this glide surfaces with its consonantal features, which will lead to a string of five root consonants which is not permitted by the language in the derivation of BP, and consequently a consonant must be deleted to satisfy the maximum root consonant constraint which restricts the number to only four. This should not cause a problem, because this glide surfaces with its vocalic features in both the singular form as well as the BP form. Consider the examples below:

a.  $/C_1aC_2C_3a:C_4/$

(426)  $/d_1ak_2k_3a:n_4/$ , 'shop'

$/d_1ak_2a:k_3i:n_4/$

$/s^{\text{f}}_1ab_2b_3a:t^{\text{f}}_4/$ , 'shoes'

$/s^{\text{f}}_1ab_2a:b_3i:t^{\text{f}}_4/$

In the two singular forms, the identical medial consonants are genuine root consonants and they are not the result of a morphological process since neither form has a corresponding triliteral form. Thus, the underlying structure of /d<sub>1</sub>a.k<sub>2</sub>a:k<sub>3</sub>i:n<sub>4</sub>/, for example, will have the structure [√dkka:n, + /a: /]. After identifying the active morphological site of BP, the structure will be [√dka:ka:n]. This input is processed in order to achieve its optimal BP form:

(427)

Input: [dkâ :ka :n]	*COMPLEX	GLIDE-FRONTING	OCP	MAX	IDENT
a. → /d <sub>1</sub> a.k <sub>2</sub> a:k <sub>3</sub> i:n <sub>4</sub> /					*
b. /d <sub>1</sub> a.k <sub>2</sub> a:k <sub>3</sub> a:n <sub>4</sub> /		*!			
c. /d <sub>1</sub> k <sub>2</sub> a:k <sub>3</sub> i:n <sub>4</sub> /	*!				*

Although all the candidates fulfil the maximality constraint which requires all the input segments to be present in the output, and they all also satisfy the OCP constraint, BP derivation requires the fronting of the features of the long vowel which takes the position of the nucleus of the third syllable. Candidate (c) is ruled out by the top ranked constraint which militates against consonant clusters resulting from any derivational morphological process. By ranking the identity constraint lower than the constraint motivated by the BP derivational process, which requires the fronting of long vowels which are at the underlying level represented as glides, candidate (a) outranks candidate (b). Thus, the optimal candidate (a) satisfies all the dominant constraints but only minimally violates the low ranked constraint.

In the following instances (b)-(f), the derivation of the BP forms is similar to that of /d<sub>1</sub>a.k<sub>2</sub>a:k<sub>3</sub>i:n<sub>4</sub>/ . The only reason to cite these examples here and elsewhere is to show the diversity of the short vowels in the singular forms which do not play any role in the derivational process of BP. Another reason is to show that, regardless of the quality of the final long vowels, BP formation requires long vowels to be fronted. As is the case in (e) and (f), suffixes are deleted in the derivation of BP:





are restricted to /a/ if the BP morpheme is hosted in C<sub>2</sub> and if there is no neighbouring glide /j/. The question is whether or not there is a constraint which militates against the coexistence of instances of a consecutive /a:/ with any other long vowel other than /i:/ which can be motivated phonologically. BP formation shows that the front vowel /i/ is epenthesized to break consonant clusters and its long form corresponds to any long vowel in the input.

f. /C<sub>1</sub>vC<sub>2</sub>C<sub>3</sub>a:C<sub>4</sub>at/

The singular forms have identical medial consonants positioned in C<sub>2</sub> and C<sub>3</sub>. Both corresponding identical segments of the singular form and its corresponding plural form are governed by the constraint OCP, by which the distance between the identical segments is respected in such a way that the spreading of the segments in the input form is maintained in the output plural form, for example:

(432)      /k<sub>1</sub>ur<sub>2</sub>r<sub>3</sub>a:s<sub>4</sub>-at/, ‘book note’                      /k<sub>1</sub>ar<sub>2</sub>a:r<sub>3</sub>i:s<sub>4</sub>/  
               /d<sub>1</sub>ar<sub>2</sub>r<sub>3</sub>a:ʒ<sub>4</sub>-at/, ‘bicycle’                              /d<sub>1</sub>ar<sub>2</sub>a:r<sub>3</sub>i:ʒ<sub>4</sub>/

Both corresponding forms show that the syllabification of the identical segments meets the spreading requirements governed by the constraint OCP.

In the following examples, two phonological processes shape the above BP form. The first is the option of avoiding the initial consonant cluster which results from the morphological process. The initial consonant is syllabified as a light syllable and then the unstressed vowel of the light syllable is deleted and an epenthetic vowel plus an epenthetic glottal stop are inserted to create an initial closed syllable. The second is the actual surfacing of the glide which is forced to surface with its consonantal features in order to host the BP morpheme, since this glide is in the position of C<sub>2</sub>, for example:

/C<sub>1</sub>i:C<sub>3</sub>a:C<sub>4</sub>/

(433)      /ʃ<sub>1</sub>i:tʃ<sub>3</sub>a:n<sub>4</sub>/, ‘Satan’                                      /ʔ<sub>5</sub>iʃ<sub>1</sub>j<sub>2</sub>a:tʃ<sub>3</sub>i:n<sub>4</sub>/

/m<sub>1</sub>i:d<sub>3</sub>a:n<sub>4</sub>/, ‘field’

/ʔ<sub>5</sub>i m<sub>1</sub> j<sub>2</sub> a:d<sub>3</sub> i:n<sub>4</sub>/

In these singular forms, the underlying C<sub>2</sub> is a glide /j/ which surfaces with its vocalic features as a long vowel in the singular forms. However, in their corresponding BP forms, the glide surfaces with its consonantal features in order to host the BP morpheme. If the glide did surface with its vocalic features, this would cause a failure to identify the active morphological site for the BP morpheme and may also cause the misplacement of this morpheme either in C<sub>1</sub> or C<sub>3</sub>. Thus, the glide has to surface with its consonantal features to form with the BP morpheme as an independent syllable. Taking /ʔ<sub>5</sub>i j<sub>2</sub> a:t<sub>3</sub> i:n<sub>4</sub>/ as an example, this BP has the underlying structure [ʔ<sub>5</sub> j t<sub>3</sub> a:n, + /a: /], which after the morphological process yields the structure [ʔ<sub>5</sub> j a:t<sub>3</sub> a:n]:

(434)

Input: [ʔ <sub>5</sub> j a:t <sub>3</sub> a:n]	*COMPLEX	GLIDE-FRONTING	*CV	IDENT	DEP
a. → /ʔ <sub>5</sub> i j <sub>2</sub> a:t <sub>3</sub> i:n <sub>4</sub> /				*	*
b. /ʔ <sub>5</sub> i j <sub>2</sub> a:t <sub>3</sub> i:n <sub>4</sub> /			*	*	
c. /ʔ <sub>5</sub> j <sub>2</sub> a:t <sub>3</sub> i:n <sub>4</sub> /	*!			*	
d. /ʔ <sub>5</sub> i j <sub>2</sub> a:t <sub>3</sub> a:n <sub>4</sub> /		*!			*

If the glide surfaces with its vocalic features, this creates a string of vowels which are at least trimoraic with the vowels of the BP morpheme. Consequently, such a candidate is eliminated. Candidate (d) is excluded because it fails to raise the long vowel. Candidate (c) has an initial complex onset which is not permitted by the language. Therefore, the top ranked constraints eliminate both candidates (d) and (c). Because DEP is ranked very low, the only difference between the winner (a) and the loser (b) is the ranking of \*CV higher than DEP since the language tends to avoid light syllables.

#### 7.4.2 Form /C<sub>1</sub>aC<sub>2</sub>a:C<sub>3</sub>C<sub>4</sub>-at/

Two derivational processes take place in this form. The first is morphological, deriving the BP by infixing the BP morpheme /a:/ after C<sub>2</sub>; and the second is a



of light syllables. This gives preference to the syllabification of the optimal output. However, as far as the morphological process is concerned, the optimal output is not faithful to the input root segments. The long vowel in the singular forms, which could be said to be present at the underlying level as a glide, does not surface at all.

(437)

Input: [dkâ : tu : rɸ]	*5 CONSONANTS	*4 SYLLABLES	MAX
a. → /d <sub>1</sub> a.k <sub>2</sub> a : t <sub>3</sub> .r <sub>4</sub> at/			*
b. /d <sub>1</sub> a.k <sub>2</sub> a : .t <sub>3</sub> u : .r <sub>4</sub> at/		*!	
c. /d <sub>1</sub> a.k <sub>2</sub> a : .t <sub>3</sub> w <sub>5</sub> .r <sub>4</sub> at/	*!		

Actually, the deletion of the long vowel could be the consequence of two constraints. If the assumed glide surfaces as a consonant, as in (c), this increases the number of root consonants to more than the maximum permitted number which is four. If the glide surfaces as a long vowel, as in (b), this increases the number of syllables to four, two of which are consecutive heavy syllables. Thus, as a consequence of ranking the prosodic constraints higher and lowering the faithfulness constraint, the long vowel is deleted.

It must be noted that, in all the examples mentioned above, the BP morpheme usually does not stand alone in the derived words without the suffix /t/. The process of plural formation is carried out by the BP morpheme /a :/ after C<sub>2</sub> and by the suffix /t/ at the same time. Hence, these derived words are simultaneously morphologically and semantically triggered in such a way that neither effect can be achieved alone. Such words are considered as relative adjectives, which denote that a person or a thing belongs and is connected to other individuals as one homogenous group or family. This is exactly what the collective noun refers to. The pluralisation process means in a sense that the BP morpheme designates the huge number of individuals and the collective noun morpheme /t/ designates these individuals as one group.

### 7.4.3 Form /C<sub>1</sub>aC<sub>2</sub>a : C<sub>3</sub>iC<sub>4</sub>/

a. /C<sub>1</sub>aC<sub>2</sub>C<sub>3</sub>aC<sub>4</sub>/







consonant, the BP morphological process results in the structure  $\sqrt{\text{na:kbu:t}}$ . However as can be seen from the optimal output, two elements are deleted. They are the long vowel /u:/ and the fifth root consonant. Interestingly, the deletion of the long vowel is motivated by the fact that long vowels are at the underlying level considered as glides (Levy, 1971; Brame, 1970; Rosenthal, 2006). Since they are glides, they have consonantal and vocalic features. However, the syllabification of the third root consonant /k/ could be the effect of the deletion of the two elements. Because the second root consonant plus the BP morpheme produce a well-formed syllable, and also because in general the second root consonant and the BP morpheme tend to favour a heavy open syllable, syllabifying /k/ with this syllable will increase the weight of the syllable so that it is superheavy. Thus, /k/ has to establish a new syllable. This can be illustrated that throughly considering the active constraints on three possible candidates in the following tableau.

(443)

Input: [ʔnâ:kbu:t]	*5 <sub>CONSONANTS</sub>	*COMPLEX	*CV:C-MEDIAL	MAX
a. → /ʔ <sub>1</sub> a.n <sub>2</sub> a:k <sub>3</sub> ɪb <sub>4</sub> /				**
b. /ʔ <sub>1</sub> n <sub>2</sub> a:k <sub>3</sub> b <sub>4</sub> /		**!		**
c. /ʔ <sub>1</sub> a.n <sub>2</sub> a:k <sub>3</sub> .b <sub>4</sub> u:t <sub>5</sub> /	*!		*	

The faithful candidate (c) violates two constraints. It exceeds the maximum permitted number of consonants, which actually, given the addition of the underlying glide, are six. The other violation is caused by the way the third consonant is syllabified. It is augmented as a mora with an already heavy syllable. There is no phonological motivation to create this superheavy syllable, for example by the deletion of a short vowel. Although candidate (b) satisfies the maximum consonant constraint, the consonants are adjoined together creating complex consonant clusters which are not favoured by the language. Candidates (b) and (a) both violate the low ranked MAX constraint in order to satisfy the maximum consonant constraint. However, candidate (a) wins because it successfully breaks up the consonant clusters with epenthetic vowels.

b. /C<sub>1</sub>iC<sub>2</sub>C<sub>3</sub>a:C<sub>4</sub>iC<sub>5</sub>/

(444) /b<sub>1</sub>i r<sub>2</sub> n<sub>3</sub> a : m<sub>4</sub> i ʒ<sub>5</sub>/, ‘programme’                      /b<sub>1</sub> a r<sub>2</sub> a : m<sub>4</sub> i ʒ<sub>5</sub>/

What is interesting about this BP form is the deletion of the medial consonant. Although the singular is a borrowed word from a European language, there are four root consonants in the verb form /barmaʒ/, ‘to programme/plan’. In the derivation of the singular noun, an epenthetic /n/ is inserted medially. This epenthetic consonant, and none of the root consonants, is deleted when the BP form is derived:

(445)

Input: [brâ : na : mʒ]	*5 <sub>CONSONANTS</sub>	*COMPLEX	*4 <sub>SYLLABLES</sub>	MAX
a. → /b <sub>1</sub> a.r <sub>2</sub> a : .m <sub>4</sub> iʒ <sub>5</sub> /				**
b. /b <sub>1</sub> r <sub>2</sub> a : m <sub>4</sub> ʒ <sub>5</sub> /		*!		**
c. /b <sub>1</sub> a.r <sub>2</sub> a : .n <sub>3</sub> a : m <sub>4</sub> ʒ <sub>5</sub> /	*!	*		
d. /b <sub>1</sub> a.r <sub>2</sub> a : .n <sub>3</sub> a : .m <sub>4</sub> iʒ <sub>5</sub> /	*!		*	

The faithful candidates (d) and (c) both violate the maximum root consonants constraint. However, the difference between them reflects a fact about the maximum number of syllables permitted in the derivation of BP, which must be no more than four. Candidate (c) satisfies this, but it violates the constraint which militates against consonant clusters, whereas candidate (d) avoids the cluster by violating the constraint which militates against excessive syllables. Although these two candidates are ruled out by the higher ranked constraint \*5<sub>CONSONANTS</sub> and are both faithful to the underlying form, the syllabification preference and the tendency to avoid consonant clusters in the derivation of BP play the main role in eliminating the candidates (d), (c), and (b). Candidate (a) is the winner because it respects all three top constraints.

## 7.6 Foreign Loanwords in LA

Foreign loanwords here refer to those borrowed from any language other than CA, as Arabic represents the underlying morphological and phonological structure of LA. The close relationship between Arabic and LA is motivated by the morphological derivational processes which exhibit the role of the root consonants and the active

morphological sites. The adoption of foreign loanwords reflects fundamental facts about the phonology and morphology of the host language. In LA, many loanwords are borrowed from different languages such as Berber, Turkish, Italian, and English. Such languages have different morphological and phonological structures which distinguish them from LA. Thus, it is very interesting to look at the behaviour of some representative foreign loanwords when they form BP.

As an overgeneralisation, foreign loanwords form plurals by taking the FSP suffix /a:t/. This fact seems to represent the first morphological adaptation process by the language in order to subject these loanwords to the derivational morphological process of pluralisation. From the research of BP formation, it is revealed that the derivational process of BP is achieved by identifying the active morphological site which hosts the BP morpheme. In that derivational process, the BP morpheme is either hosted after C<sub>1</sub> in a monosyllabic structure or after C<sub>2</sub> or C<sub>3</sub> in other syllabic structures. Also, it has been observed that the root consonants play the main role in deriving lexical words in the sense that words derived from the same root consonant share a semantic meaning. It would not be surprising for a foreign loanword to qualify for FSP, since this loanword in this case is treated as a stem word. However, it would be surprising if a loanword qualified for a BP form. In this case, the BP morpheme is morphologically able to identify the active morphological host site. The representative examples below show that foreign loanwords can form BP and they are governed by the active morphological and phonological constraints of LA.

1. /CvCaC/

In this form, the short vowel BP morpheme /a/ is hosted after the second consonant. The first vowel is phonologically supplied and does not carry any morphological information. This judgment is supported by the fact that the initial vowel is subject to deletion because it occurs in the position of an unstressed light syllable, for example:

(446)	/warʃ-at/, ‘workshop’	/ʔuraʃ/	‘English’
	/ʃing-at/, ‘chain’	/ʔiʃnag/	‘Italian’
	/go:m-at/, ‘tyre’	/ʔagwam/	‘Italian’

/be:l-at/, 'torch'

/ʔibjal/

'Italian'

These examples represent certain facts about adaptation to the morphology and the phonology of the language. If we take the correspondence relations between the input (singular foreign loanword) and the output (its BP correspondent), there is no morphological or phonological correspondence at all. It is obvious that the singular form is not considered as a stem word when the derivational process of BP takes place. What stands in correspondence, in fact, is the string of root consonants. This is exactly how the derivation of non-concatenative morphology works in LA. That is to say, the derivational morphological process picks up the root consonants of the singular form and subjects them to the derivational process of BP formation. At the underlying level of the BP process, the input is the root consonants plus the BP morpheme identified after C<sub>2</sub>. Then, at the surface of the derived word, the phonology operates in order to maintain the optimal output as well-structured based on the satisfaction of the top ranked constraints of the language. An illustrative example could be /warʃ-at/, in which the suffix /-t/ of the singular form marks the singulative since this BP form is similar to the structure of the collective noun. The existence of this suffix may explain why the corresponding BP form has this structural form. This BP form is always associated with the structure of the collective noun. It seems that the pluralisation process identifies the collective noun structure as the plural of the corresponding singular form. As far as the derivational morphological of BP process is concerned, the suffix is deleted and the underlying structure of the BP form consists of the root consonants plus the BP morpheme, which yields the structure [ $\sqrt{\text{wra}}\text{ʃ}$ ]. This structure is the output of the morphological derivational process. The phonological process takes this structure as an input to subject it to the relevant active phonological constraints in order to maintain that the optimal candidate as phonologically well-structured. The following tableau represents some possible output candidates.

(447)

Input: [wrâʃ]	*COMPLEX	*[w_]STEM	ONSET	MAX
a. → /ʔuraʃ/				
b. /uraʃ/			*!	
c. /waraʃ/		*!		
d. /wraʃ/	*!			

As is usually the case with the output of a derivational morphological process, it consists of complex margins. At the surface level, such margins are not allowed in derived words, and consequently the top ranked constraint which militates against consonant clusters rules out candidate (d). The other three candidates (c), (b), and (a) show some restrictions on the surfacing of the initial glide /w/. The language usually tends to avoid either the consonantal or vocalic features of this glide, and as in some cases it is deleted altogether if it is in the initial position of the word. The optimal output (a) shows that the vocalic features of the glide must be maintained. This motivates the maximality constraint to be positioned among the top ranked constraints. The importance of the MAX constraint is its twofold use with glides. On the one hand it preserves the consonantal features of the glide, and on the other it preserves its vocalic features. Thus, MAX here assures that deletion should not be tolerated. Whether the glide surfaces with its consonantal or vocalic features depends upon the other two markedness constraints \*[w\_]STEM and ONSET. However, if the glide surfaces with its consonantal features, this will cause the violation of the constraint militating against initial glides, and if the glide surfaces with its vocalic features that will cause the creation of an onsetless syllable. Thus, whatever the ranking of the constraints, the optimal candidate must satisfy all of them. This is exactly why candidate (a) is selected as the winner.

## 2. /CvCv:C/

This BP form exhibits the long vowel BP morpheme after C<sub>2</sub>. In the examples below, the second syllable is already identified as a heavy syllable according to the length of the BP morpheme. However, the initial syllable is in fact an open light syllable, which could be assumed for each of the BP words below. Since the initial syllable is unstressed, the vowel is deleted and a new syllable is created by inserting a short vowel plus a glottal stop, for example:

(448)	/gazar/, ‘drawer’	/ʔagʒu:r/	‘Spanish’
	/bank/, ‘bank’	/ʔabnu:k/	‘English’
	/go:l/, ‘goal’	/ʔagwɑ:l/	‘English’
	/ħukk-at/, ‘can’	/ʔaħka:k/	-

How the morphological process identifies the position of the BP morpheme in /go:l/ and /ħukk-at/ must now be considered, since they may both cause a problem if the morphophonological constraints of the language are not taken into consideration. In /go:l/, the singular has a biconsonantal surface structure. In the derivational process, the derived word must minimally have three root consonants. This causes no problem as the singular has a long vowel; the morphological derivational process identifies the length of the long vowel as a glide, which is usually how the language treats surfacing long vowels. In deriving BP, the underlying assumed glide has to surface with its consonantal features in order to host the BP morpheme; otherwise the BP morpheme cannot identify the target active morphological site. The second word /ħukk-at/ has two identical final root consonants which are governed by the OCP which requires the spreading of identical segments. The BP form shows that the BP morpheme is hosted after the first identical consonant which at the same time represents the second root consonant of the word. The spreading of the identical segments is maintained by the fact that the second identical segment is positioned as an extrasyllabic segment.

### 3. /CaCa:CaC/

The second consonant of this BP form either corresponds to the second root consonant or to the length of the long vowel of the corresponding singular form. If the corresponding singular has a long vowel positioned after C<sub>1</sub>, then in the BP form this long vowel is realized as a glide /w/. Such behaviour is similar to that of the morpheme of the active participle form /Ca:CaC/ which is realized as /w/ when it forms BP. Thus, foreign loanwords having such a structure are subject to having a glide in the second position of the BP form. Consider the following examples:

(449)	/ro:ʃin/, ‘window’	/rawa:ʃin/	‘Persian’
-------	--------------------	------------	-----------



/sa:ɡim/, ‘large spoon’	/sawa:ɡim/	‘Berber’
/so:ri:j-at/, ‘shirt’	/sawa:ri:/	‘Berber’
/xɑ:nib/, ‘thief’	/xawɑ:nib/	‘Hebrew’

All the long vowels of the singular forms correspond to a glide /w/ in the BP forms. Although the long vowels of the loanwords do not carry morphological information, as in LA, the length of the vowels is preserved as a glide in the BP form. It is not explicitly assumed in this study that the active participle morpheme is at the underlying level represented as a glide /w/. But whatever the quality of the underlying glide, it seems that the glide is the actual realization of or compensation for a corresponding long vowel. Thus, in the underlying structure, the length of the long vowel of the foreign loanword should be considered as a glide; otherwise the surfacing of the glide in the BP may not be justified. In considering the underlying structure of the BP derivational process of the Persian word /ro:ʃin/, its underlying structure is morphologically realized as [√rwa:ʃn] as in the tableau below:

(450)

Input; [rwâ:ʃn]	*COMPLEX	ONSET	DEP
a. → /ra.wa:ʃin/			**
b. /ro.a:ʃin/		!*	*
c. /rwa:ʃn/	!*		

In candidate (c), the consonant clusters resulting from the morphological process are ruled out by the constraint which militates against margin clusters. The problem with candidate (b), which is caused by the glide surfacing with its vocalic features, is the fact that the BP morpheme is left onsetless. This is not tolerated in the language, which requires the obligatory filling of the onset. The winning candidate (a) has no problem as it fulfils the two top ranked constraints fully, although the additional segments violate the least ranked constraint DEP.

If the second root consonant is in place and is identified by the morphological process, the derivational process, in which such a consonant is identified as the host of the BP morpheme, is straightforward, as in the following examples:

(451)	/ʔibre:z-at/, ‘socket’	/barɑ:jiz/	‘Italian’
	/sibsi:/, ‘cigarette’	/saba:si:/	‘Berber’
	/kundar-at/, ‘shoes’	/kana:dir/	‘Turkish’
	/kabtin/, ‘captain’	/kaba:tin/	‘English’
	/ʃabtir/, ‘chapter’	/ʃaba:tir/	‘English’

In these examples, the active derivational site is identified after the existing second root consonant  $C_2$ . The underlying structure of each BP form in these examples consists of a complex onset and complex coda, and the BP morpheme is hosted after  $C_2$ . For example, the BP form /barɑ:jiz/ has the underlying structure [ $\sqrt{\text{bra:jz}}$ ] in which the glide /j/ corresponds to the long vowel /e:/ in the corresponding singular form /ʔibre:z-at/. It must be noted that the initial glottal stop of the singular is the consequence of avoiding the initial cluster of the loanword. At the surface level, phonological constraints come into play to repair the consonant clusters which result from the morphological process. Thus, the function of the active top ranked constraint \*COMPLEX, for example, is to resyllabify the clusters in such a way that the optimal output is well-structured even though the price is having to rank the constraint DEP as low in order to insert segments which do not have corresponding relationships with the underlying structure.

#### 4. /C<sub>1</sub>aC<sub>2</sub>a:C<sub>3</sub>i:C<sub>4</sub>/

All the singular loan words which qualify for this BP form have disyllabic heavy syllable structures. The first syllable is the closed heavy syllable /CvC/ or the open heavy /Cvv/, and the second is the super heavy /CvvC/. We have just discussed in the previously mentioned forms the identification of the active morphological site to host the BP morpheme in the initial syllable forms. However, what is of interest in the second heavy syllable is its long vowel and its correspondent in the BP form. First, the long vowel does exist in the BP form. However, no claim of long vowel transfer is made, here, since the existence of the long vowel is actually the vocalic realization of the underlying glide which is represented by the surfacing of the long vowel. That is to say, the underlying glide cannot surface. If it did it would create a string of five root consonants, which is not permitted in the language. The constraint \*5<sub>CONSONANTS</sub> will

truncate one of the rightmost root consonants. In order to avoid such a truncation, the glide has to surface with its vocalic features, and in this way the trace of the root consonant is maintained in the vocalic features of the glide and consequently the maximality constraint is satisfied. Second, whatever the quality of the long vowel of the singular form, in forming the BP this long vowel must be fronted in compatibility with the requirements of BP derivation. The behaviour of these loanwords when they qualify for this BP form is similar to that of LA generally.

(452) /ʒirdi:n-at/, ‘garden’	/ʒarɑ:di:n/	‘Italian’
/fa:tu:r-at/, ‘invoice’	/fawa:ti:r/	‘Italian’
/finʒa:l/, ‘cup’	/fana:ʒi:l/	‘Turkish’
/fakru:n-at/, ‘turtle’	/faka:ri:n/	‘Berber’
/gatʔtʔu:s/, ‘cat’	/gatʔɑ:tʔi:s/	‘Spanish’
/ʃiyʃi:r/, ‘socks’	/ʃayɑ:ʃi:r/	‘Persian’
/balako:n-at/, ‘balcony’	/bala:ki:n/	‘Italian’
/talafo:n/, ‘telephone’	/tala:fi:n/	‘English’

As the BP correspondents in the above examples show, the final long vowel is always /i:/ whatever the vowel quality of the corresponding singulars. Thus, the underlying glide of the singular has to be fronted as glide /j/, and the constraint which militates against exceeding the permitted number of root consonants forces this glide to surface with its vocalic features as /i:/.

## 7.7 Multiple BP Candidates

In the derivational morphological process of BP, a singular form may qualify for more than one BP form. The diversity of BP forms associated with one singular form can be explained according to morphophonological, morpho-semantic or syntactic interactions. This is because each BP form designates a meaning different from the other qualifying BP form, and each BP form is also distinguished by its associated morphological morphemes.

1. /C<sub>1</sub>a:C<sub>2</sub>iC<sub>3</sub>/

This singular form is associated with the masculine active participle. The long vowel /a: / is actually the active participle morpheme which we have considered a morphological property of the singular form which is subject to be carried over to the output BP form. In the output BP form, the active participle morpheme surfaces not as /a: / but rather as a consonantal glide /w/ or its correspondent vocalic features /u/. At first sight, there seems to be no relation between the active participle morpheme /a: / and its corresponding glide found in the BP form. However, if we expect the participle morpheme to surface as a glottal stop, which is a plausible assumption since both share phonetic features, then such surfacing is subject to phonological constraints because the language tends to constrain the appearance of the glottal stop. The only case we have come across is the appearance of the glide /j/ as a glottal stop in the final syllable in the derivation of active participles. For example, the derivation of the active participle from its corresponding trilateral root word such as  $\sqrt{\text{sjr}}$  + /a: / gives the optimal output [sa:ʔir].

In the derivation of BP, the glide /w/ with either consonantal or vocalic features corresponds to the active participle morpheme /a: /. This suggests that, for some phonological and morphological constraints, the participle morpheme has to surface as the glide /w/. Phonologically, as mentioned above, there could be some restrictions on the surfacing of the glottal stop as a compensation for the participle morpheme /a: /. Morphologically, because the glide /w/ is identified as the active morphological site which hosts the BP morpheme, the glottal stop cannot carry any morphological information since it is subject to phonological changes. Consequently, its replacement by the glide is preferred.

An other suggestion, although no solid evidence is available, is to suggest that the active participle morpheme is actually a glide /w/ but, because of some phonological constraints, it surfaces as /a: /. This might make sense given that the long vowels are actually represented as diphthongs at the underlying level. Nevertheless, whatever the actual representation of the long vowels, the glide /w/ corresponds morphologically to

the active participle morpheme /a :/. There is no reason to believe otherwise, since the existence of /w/ in the BP form and its obvious morphological function in hosting the BP morpheme cannot be justified as far as input-output relations are concerned.

From the list of BP forms below, an attempt is made to establish a morpho-semantic distinction between the BP candidates.

(453)	Singular Form	1 <sup>st</sup> BP Candidate	2 <sup>nd</sup> BP Candidate
	/ħ <sub>1</sub> a : r <sub>2</sub> i s <sub>3</sub> /, ‘guard’	/ħ <sub>1</sub> ur <sub>2</sub> r <sub>2</sub> a : s <sub>3</sub> /	/ħ <sub>1</sub> ar <sub>2</sub> a s <sub>3</sub> /
	/x <sub>1</sub> a : d <sub>2</sub> i m <sub>3</sub> /, ‘servant’	/x <sub>1</sub> ud <sub>2</sub> d <sub>2</sub> a : m <sub>3</sub> /	/x <sub>1</sub> ad <sub>2</sub> a m <sub>3</sub> /

The doubling of the medial root consonant in the first set of pairs above is a morpho-semantic function of Arabic which designates the intensity and/or the multiplicity of the action in verbs and of the quantity in nouns. In fact, the BP morpheme in /ħ<sub>1</sub>ur<sub>2</sub>r<sub>2</sub>a : s<sub>3</sub>/, for instance is the long vowel /a :/. The medial consonant is doubled to express the fact that the action is repeatedly and continuously done for a long time. Recall that one of the functions of doubling medial root consonants in nouns is to denote profession. Thus, the sense of repetition expressed in the nouns is to designate profession. The second BP correspondent candidate /ħ<sub>1</sub>ar<sub>2</sub>a s<sub>3</sub>/ is in fact the collective noun which has the function of referring to the individuals as one group. This collective noun is unmarked, since it lacks the usual suffix /t/ which marks the singular form associated with some collective noun forms. The distinction between the two BP forms is that; the first expresses that the members of the group are individuals, while the second expresses the unity of the individuals as one group. The collective noun in the following examples shows the singulative suffix /t/:

(454)	/t <sup>ʔ</sup> <sub>1</sub> a : l <sub>2</sub> i b <sub>3</sub> /, ‘student’	/t <sup>ʔ</sup> <sub>1</sub> ul <sub>2</sub> l <sub>2</sub> a : b <sub>3</sub> /	/t <sup>ʔ</sup> <sub>1</sub> al <sub>2</sub> ab <sub>3</sub> -at/
	/k <sub>1</sub> a : f <sub>2</sub> i r <sub>3</sub> /, ‘infidel’	/k <sub>1</sub> uf <sub>2</sub> f <sub>2</sub> a : r <sub>3</sub> /	/k <sub>1</sub> af <sub>2</sub> ar <sub>3</sub> -at/

It must be noted that the active participle morpheme is an adjectival morpheme. However, the examples above show that when the BP is formed the grammatical category may be subject to change. In the first BP form, the derived word is

considered either as an adjective or a noun depending on the context, while in the second BP form there is no doubt that the grammatical category is a noun.

The set of pairs below shows that the preferred adjectival morpheme position is after C<sub>3</sub> of the root consonant. Regardless of the first BP form, which could be either a noun or an adjective, the second BP form is an adjectival form denoted by the existence of the adjectival long vowel morpheme /a:/. In fact, because the derived word is an adjective, the long vowel represents both the BP morpheme and the adjectival morpheme. The shift of the BP morpheme from C<sub>2</sub>, which is usually the case in nouns, to C<sub>3</sub> is motivated by the grammatical state of the derived word which is the adjective form. That is to say, the syntactic category of /ʃ<sub>1</sub>uʔ<sub>2</sub>a:r<sub>3</sub>a:ʔ/, for instance, is assigned as an adjective, while /ʃ<sub>1</sub>uʔ<sub>2</sub>ʔ<sub>2</sub>a:r<sub>3</sub>/ has the option of being assigned as an adjective or a noun depending on the context.

- (455) /ʃ<sub>1</sub>a:ʔ<sub>2</sub>i:r<sub>3</sub>/, ‘poet’                      /ʃ<sub>1</sub>uʔ<sub>2</sub>ʔ<sub>2</sub>a:r<sub>3</sub>/    /ʃ<sub>1</sub>uʔ<sub>2</sub>a:r<sub>3</sub>a:ʔ/  
           /ʒ<sub>1</sub>a:h<sub>2</sub>i:l<sub>3</sub>/, ‘ignorant’                /ʒ<sub>1</sub>uh<sub>2</sub>h<sub>2</sub>a:l<sub>3</sub>/    /ʒ<sub>1</sub>uh<sub>2</sub>a:l<sub>3</sub>a:ʔ/

In the BP form /C<sub>1</sub>aw<sub>4</sub>a:C<sub>2</sub>iC<sub>3</sub>/, the glide /w/ is the actual consonantal surface of the corresponding active participle /a:/. There is no obvious reason to suggest that this BP is an adjective, since in the morphological derivational process associated with BP if the derived word is an adjective, then the adjective morpheme appears after C<sub>3</sub>. However, this BP is not associated with any adjective morpheme. It could be said that the BP form acquires the noun state and is no longer an adjective (Samirrai, 2007, 136). From a correspondence point of view, this BP form is a noun. It could be said that the second BP form /C<sub>1</sub>uC<sub>2</sub>C<sub>3</sub>a:n<sub>5</sub>/ has the adjective form since the BP morpheme coincides with the adjectival morpheme; both are represented as /a:/, after C<sub>3</sub>. However, the existence of and motivation for the appearance of /n/ as a suffix is not clear. Arabic grammarians consider this /n/ in the derivation of BP as a suffix attached to adjectives to transform them into nouns (Sibawayh, 1999; Samirrai, 2007), for example:

- (456) /f<sub>1</sub>a:r<sub>2</sub>i:s<sub>3</sub>/, ‘knight’                      /f<sub>1</sub>aw<sub>4</sub>a:r<sub>2</sub>i:s<sub>3</sub>/                      /f<sub>1</sub>ur<sub>2</sub>s<sub>3</sub>a:n<sub>5</sub>/

/r<sub>1</sub>a:ʔ<sub>2</sub>i/, ‘shepherd’      /r<sub>1</sub>aw<sub>4</sub>a:ʔ<sub>2</sub>i/      /r<sub>1</sub>iʔ<sub>2</sub>j<sub>3</sub>a:n<sub>5</sub>/

2. /C<sub>1</sub>aC<sub>2</sub>i:C<sub>3</sub>/

The long vowel /i:/ is an adjectival morpheme which designates the constant and dominant characteristics associated with the object being described. Such characteristics have a similar status in terms of stability to that of the noun state. In other words, these characteristics either do not have a time reference or they last for a long period of time. For example, when the adjectives /t<sup>ʔ</sup>awi:l/, ‘tall’, /qas<sup>ʔ</sup>i:r/, ‘short’, and /kari:m/, ‘generous’ describe an object, they usually describe the productivity and the continuity of these characteristics. In the derivation of the BP from a corresponding singular form which exhibits such a morpheme, the morpheme is preserved in the output adjectival BP form and lost from the noun form. Furthermore, as an adjectival morpheme, it has at least two varieties i.e. [a:] and [i:]. There is also diversity in the process of syllabification process of the adjectival BP forms.

(457) /m<sub>1</sub>ar<sub>2</sub>i:d<sup>ʔ</sup><sub>3</sub>/, ‘ill’      /ʔ<sub>4</sub>im<sub>1</sub>r<sub>2</sub>a:d<sup>ʔ</sup><sub>3</sub>/      /m<sub>1</sub>ar<sub>2</sub>d<sup>ʔ</sup><sub>3</sub>a:/  
       /m<sub>1</sub>aj<sub>2</sub>j<sub>4</sub>it<sub>3</sub>/, ‘dead’      /ʔ<sub>4</sub>im<sub>1</sub>w<sub>2</sub>a:t<sub>3</sub>/      /m<sub>1</sub>aw<sub>2</sub>t<sub>3</sub>a:/

The difference between the first BP candidate above and the second reveals why the singular form has two possible candidates. If the position of the BP morpheme is considered, it is obvious that in the first instance it occupies the position after C<sub>2</sub>, while in the second it occupies the position after C<sub>3</sub>. This is very important, since the first form has in fact what looks like a BP noun form, whereas the second is an adjectival form because of the position of the adjectival morpheme which coincides with the BP morpheme. It must be noted that this adjectival morpheme has a specific meaning and it is always associated with specific adjectives which have a passive meaning. This meaning denotes, for example, physical and mental defects and diseases. For instance, the difference between /ʔ<sub>4</sub>im<sub>1</sub>w<sub>2</sub>a:t<sub>3</sub>/ and /m<sub>1</sub>aw<sub>2</sub>t<sub>3</sub>a:/ is that the latter denotes the actual physical state of being dead, while /ʔ<sub>4</sub>im<sub>1</sub>w<sub>2</sub>a:t<sub>3</sub>/ could refer to the death state physically or morally or both (Samirrai, 2007, 115-116). The

other meaning of the adjectival morpheme /a:/ is to denote the instinct and good characteristics associated with masculine human, for example:

- (458) /d<sup>ʕ</sup><sub>1</sub>aʔ<sub>2</sub>i:f<sub>3</sub>/, ‘weak’                      /ʔ<sub>4</sub>i d<sup>ʕ</sup><sub>1</sub>ʔ<sub>2</sub>a:f<sub>3</sub>/                      /d<sup>ʕ</sup><sub>1</sub>uʔ<sub>2</sub>a f<sub>3</sub>a:ʔ/  
           /k<sub>1</sub>a r<sub>2</sub>i:m<sub>3</sub>/, ‘generous’                      /ʔ<sub>4</sub>i k<sub>1</sub> r<sub>2</sub>a:m<sub>3</sub>/                      /k<sub>1</sub>u r<sub>2</sub>a m<sub>3</sub>a:ʔ/  
           /k<sub>1</sub>a b<sub>2</sub>i:r<sub>3</sub>/, ‘big’                              /ʔ<sub>4</sub>i k<sub>1</sub> b<sub>2</sub>a:r<sub>3</sub>/                      /k<sub>1</sub>u b<sub>2</sub>a r<sub>3</sub>a:ʔ/

The second BP form exhibits the glottal stop /ʔ/ after the long vowel, but we could ask why the preceding form /C<sub>1</sub>aC<sub>2</sub>C<sub>3</sub>a:/ does not exhibit this glottal stop. The answer could be phonologically motivated, in that the glottal stop is inserted to an already heavy stressed syllable in order to preserve the length of the long vowel which marks the weight of the syllable. In /C<sub>1</sub>aC<sub>2</sub>C<sub>3</sub>a:/, however, the stress is assigned initially to the heavy syllable and consequently the second syllable plays no role in stress assignment. For singular forms that have an identical final root consonant, /C<sub>1</sub>uC<sub>2</sub>aC<sub>3</sub>a:ʔ/ surfaces as /ʔ<sub>4</sub>aC<sub>1</sub>iC<sub>2</sub>C<sub>3</sub>a:ʔ<sub>5</sub>/, as in the following example:

- (459)        /ʃ<sub>1</sub>a d<sub>2</sub>i:d<sub>3</sub>/, ‘tough’                      /ʔ<sub>4</sub>i ʃ<sub>1</sub> d<sub>2</sub>a:d<sub>3</sub>/                      /ʔ<sub>4</sub>a ʃ<sub>1</sub> i d<sub>2</sub> d<sub>3</sub>a:ʔ<sub>5</sub>/

The difference between the two adjectival BP forms could be related to the syllabification preference. However, as a matter of fact, the initial vowel /u/ of /C<sub>1</sub>uC<sub>2</sub>aC<sub>3</sub>a:ʔ/ seems to be morphologically assigned. It may have a morphological function added to the adjectival morpheme. If the two BP forms are similar, then we expect this vowel to exist in /ʔ<sub>4</sub>aC<sub>1</sub>iC<sub>2</sub>C<sub>3</sub>a:ʔ<sub>5</sub>/ . This does not happen, and thus the short vowel actually also marks the differences between the two forms.

### 3. /ʔ<sub>4</sub>aC<sub>1</sub>C<sub>2</sub>a:/

The initial glottal stop /ʔ/ is one of the morphemes associated with adjectives which denote colours or physical and mental defects. The following examples represent adjectives which denote physical defects and have two possible BP candidates:

- (460)        /ʔ<sub>4</sub>aʔ<sub>1</sub>m<sub>2</sub>a:/, ‘blind’                      /ʔ<sub>1</sub>i m<sub>2</sub>i/                      /ʔ<sub>1</sub>i m<sub>2</sub>j<sub>3</sub>a:n<sub>4</sub>/



/ʔ<sub>4</sub>a t<sup>ɛ</sup><sub>1</sub> r<sub>2</sub> a ʃ<sub>3</sub>/, ‘deaf’      /t<sup>ɛ</sup><sub>1</sub> u r<sub>2</sub> u ʃ<sub>3</sub>/      /t<sup>ɛ</sup><sub>1</sub> i r<sub>2</sub> ʃ<sub>3</sub> a : n<sub>4</sub>/

In the first BP form, the BP morpheme is the initial vowel since the BP form is at the underlying level represented as /CvCC/. Notice that the initial vowel in /ʔ<sub>1</sub>i m<sub>2</sub>i :/ is /u/, but because LA tends to raise /u/ it is no wonder that this vowel is raised to /i/. In this form, the adjectival morpheme is not clear. On the other hand, there is no doubt that the second BP is an adjective since the BP morpheme and the adjectival one coincide after C<sub>3</sub>. Thus, the adjectival morpheme of the input is preserved in the BP output, suggesting that the BP form is grammatically assigned as an adjective. However, the existence of the suffix /n/ needs to be justified, which can be achieved by comparing the meanings of the two BP candidates. In the first BP candidate, the meaning refers to the characteristics of the individual objects as individual, whereas in the second candidate the meaning refers to those objects as one group. That is to say, the second BP candidate has a similar meaning to that of the collective noun.

Taking into consideration the phonological states of the realization of the medial glide, the BP list pairs in (4) below could be treated in the same way as the previous analysis:

4. /C<sub>1</sub>aG<sub>2</sub>C<sub>3</sub>/

(461)	/h <sub>1</sub> e : t <sup>ɛ</sup> <sub>3</sub> /, ‘wall’	/ʔ <sub>4</sub> i h <sub>1</sub> j <sub>2</sub> u : t <sup>ɛ</sup> <sub>3</sub> /	/h <sub>1</sub> i : t <sup>ɛ</sup> <sub>3</sub> a : n <sub>4</sub> /
	/x <sub>1</sub> e : t <sup>ɛ</sup> <sub>3</sub> /, ‘thread’	/ʔ <sub>4</sub> i x <sub>1</sub> j <sub>2</sub> u : t <sup>ɛ</sup> <sub>3</sub> /	/x <sub>1</sub> i : t <sup>ɛ</sup> <sub>3</sub> a : n <sub>4</sub> /
	/h <sub>1</sub> o : d <sup>ɛ</sup> <sub>3</sub> /, ‘basin/bowl’	/ʔ <sub>4</sub> i h <sub>1</sub> w <sub>2</sub> a : d <sup>ɛ</sup> <sub>3</sub> /	/h <sub>1</sub> i : d <sup>ɛ</sup> <sub>3</sub> a : n <sub>4</sub> /
	/ʔ <sub>1</sub> u : d <sup>ɛ</sup> <sub>3</sub> /, ‘match/stick’	/ʔ <sub>4</sub> i ʔ <sub>1</sub> w <sub>2</sub> a : d <sup>ɛ</sup> <sub>3</sub> /	/ʔ <sub>1</sub> i : d <sup>ɛ</sup> <sub>3</sub> a : n <sub>4</sub> /
	/n <sub>1</sub> a : b <sub>3</sub> /, ‘canine tooth’	/ʔ <sub>4</sub> i n <sub>1</sub> j <sub>2</sub> a : b <sub>3</sub> /	/n <sub>1</sub> i : b <sub>3</sub> a : n <sub>4</sub> /
	/b <sub>1</sub> a : b <sub>3</sub> /, ‘door’	/ʔ <sub>4</sub> i b <sub>1</sub> w <sub>2</sub> a : b <sub>3</sub> /	/b <sub>1</sub> i : b <sub>3</sub> a : n <sub>4</sub> /

The only difference between the first BP in (4) and its correspondent in (3) is the type of BP morpheme. In this form, the BP morpheme is a long vowel, while in the preceding one it is a short vowel.

## 7.8 Plural of the Plural

The plural of the plural in LA is not a productive process as is the case in CA. The morphological derivational process of this plural form is to subject an already marked pluralized form to another pluralisation process. Usually, the input for this type of plural is a BP form. The pluralisation process then marks this input in two ways. The first is to add the FSP suffix /a:t/ to the rightmost edge of the derived word, and the second is to follow another BP process. Consider the following examples:

- (462) /h<sub>1</sub>ar<sub>2</sub>am<sub>3</sub>/, ‘pyramid’      /ʔ<sub>4</sub>ah<sub>1</sub>r<sub>2</sub>a:m<sub>3</sub>/      /ʔ<sub>4</sub>ah<sub>1</sub>r<sub>2</sub>a:m<sub>3</sub>-a:t/  
       /q<sub>1</sub>o:l<sub>3</sub>/, ‘saying’            /ʔ<sub>4</sub>aq<sub>1</sub>w<sub>2</sub>a:l<sub>3</sub>/            /ʔ<sub>4</sub>aq<sub>1</sub>a:w<sub>2</sub>i:l<sub>3</sub>/

In /ʔ<sub>4</sub>ah<sub>1</sub>r<sub>2</sub>a:m<sub>3</sub>-a:t/, the FSP morpheme /a:t/ is suffixed to the stem BP form. Thus, the resulting plural form is marked internally by the BP morpheme and externally by the FSP morpheme. This means that there are at least two active morphological sites to host the plural markers, but such sites should not be marked both internally and externally at the same time. Rather, marking the plural must be dedicated to only one host site within the stem and only one site external to the stem. In the second word /ʔ<sub>4</sub>aq<sub>1</sub>w<sub>2</sub>a:l<sub>3</sub>/, the BP morpheme is hosted in the active morphological site after C<sub>2</sub> which is the normal process. However, in the derivation of the plural of the plural, the initial epenthetic glottal stop /ʔ/ is considered as the first root consonant, and the BP morpheme of the input surfaces as a long vowel /i:/. Hence, the morphological derivational process of the plural of the plural identifies /q/ as the second root consonant, which is in fact the first root consonant of the singular and the BP form, yielding /ʔ<sub>4</sub>aq<sub>1</sub>a:w<sub>2</sub>i:l<sub>3</sub>/. The length of the final vowel of the plural of the plural form is maintained not as a BP morpheme but rather as the preservation of the final length of the long vowel of the BP input form. In this way, /ʔ<sub>4</sub>aq<sub>1</sub>a:w<sub>2</sub>i:l<sub>3</sub>/ cannot be said to have two internal active sites to mark the plural. In this form, the morpheme /a:/ fills the position of the BP morpheme, and the final long vowel /i:/ is maintained as if it corresponds to a glide or a long vowel of the input.

## 7.9 Morpho-syntactic and Morpho-semantic Constraints on Qualifying for BP

An overall generalisation which could be made about the formation of plural types in LA is that feminine human nouns or adjectives qualify for FSP in a straightforward process, while only masculine human nouns qualify for BP. The problem arises when an adjective denoting the human masculine undergoes plural formation. In the present discussion of BP formation (in section 7.3, for example), many adjectives have been encountered that qualify for BP, yet one could count a huge number of adjectives that only assign MSP and never BP. Therefore it may seem that it is difficult to predict the type of pluralization which will occur. As soon as we account for the morpho-syntactic features of the input, whether a noun or an adjective, and cross check it with that of the corresponding derived word, we can understand the mechanism of qualifying for a specific plural type. Morpho-syntactic features refer to the derivational morphological morphemes and to the syntactic features that are assigned to distinguish each syntactic head of each nominal category whether it is a noun or an adjective. Such features and/or morphemes are morphologically assigned to a specific active derivational morphological site. Derivational morphological morphemes are positioned internally or externally to the stem, and they function not only to represent a close morphological relation between two or more related words, but also distinguish syntactic categories. For instance, the long vowel /i:/ in /nad<sup>ɛ</sup>i:f/, ‘clean’, morpho-syntactically distinguishes the adjectival category of this word, and also the long vowel /a:/ in /ka:tib/, ‘writer’, is a morpheme that distinguishes the active participle adjective. The correspondence relations between the input adjective /mar i:d<sup>ɛ</sup>/ ‘ill’ and its derived output BP /mar d<sup>ɛ</sup>a:/ shows a lack of faithfulness in morpho-syntactic features and the displacement of such features between the two related words. The adjectival morpheme /i:/, which distinguishes the syntactic category of the input as an adjective, does not show up in the output. Nevertheless, the BP form does not show the BP morpheme in its usual position in the active morphological site after C<sub>2</sub>, but rather it is shifted to the position after C<sub>3</sub>. In fact, the morpheme /a:/ in /mar d<sup>ɛ</sup>a:/ marks both the BP according to the nature of this morpheme, and the adjective by the position of this morpheme. The BP derivational process recognizes the input as a noun and not as an adjective. If the pluralization

process recognizes the input to be an adjective, it would assign SP and not BP. In fact the answer does not rely only on the morpho-syntactic features of the input. The semantic signification represented by the adjectival morpheme /i :/ also clarifies the qualification for BP. This morpheme denotes the stable state of the object regardless of time reference and/or the action itself. Because this morpheme expresses the repeated and intensive action that lasts for some long period of time, it adds some stable signification to the word it is attached to. In other words, although this morpheme denotes the adjective category, it shares some characteristics of the stable state of the noun. Consequently, the pluralization process assigns BP to the adjective input by the virtue of acquiring a stable state.

It is hard to ignore the three-way interactive relationship between morphology, semantics, and syntax when an adjective undergoes pluralization. This interactive relationship is embedded within the underlying morphological structure of any input adjective. What blocks an adjective from taking BP are the elements that are transferred from the input to the output, whether they are morphological, semantic, or syntactic features and/or derivational morphemes. Thus, if any adjective fails to qualify for BP, this could be attributed to the elements being carried over from the input. Such elements associated with an adjective usually describe the action taken by the entity. Now, the distinction between MSP and BP becomes relevant. MSP is used to describe entities in relation to the action, while BP is used to describe entities regardless of the action. The two possible plurals for /nad<sup>ɔ</sup> i : f/, for instance, are the MSP /nad<sup>ɔ</sup> i : f i : n/ and the BP /nd<sup>ɔ</sup> a : f/. In the MSP form, the MSP suffix /-i : n/ denotes the intensity of the action within a limited time; while the BP acquires the noun state by deleting the adjective morpheme and positioning the BP morpheme after C<sub>2</sub>, which is the usual process for nouns. The BP form no longer refers to the action, but rather the virtue of always being clean becomes one of the characteristics of the entity. Consequently, given these stable and permanent characteristics, the adjective acquires the noun state.

Some representative examples can be considered where adjectives fail to qualify for BP. In each example, the nature of the derivational morphological morphemes of the adjective are considered and a general account is given for some semantic features

embedded within each morpheme that block an adjective from qualifying for BP. It must be noted that adjectives which have non-human references receive FSP, and masculine human receive either /i:n/ for genitive and construct states or /u:n/ for the nominative, and, as mentioned earlier, LA tends to overgeneralize /i:n/:

In the analysis of the derivational processes of non-concatenative morphology, we have identified the morphological derivational process as consists of a string of root consonants plus in some cases any morphological components associated with the input plus the derivational morphemes of the intended derivational output process. Thus, there are no complete correspondence relations between the input and the derived output. What is of interest as far as the input is concerned are the elements that are transferred to the output. The analysis so far has not observed any phonological correspondence relations between any two related words. The correspondence relations of faithfulness accounted for concern the root consonants and the morphological morphemes found in the inputs which in some cases show up in the output. These morphological morphemes are very important in understanding the choice of pluralization. The follow representative examples for each adjective type can now be considered.

a. Verbal Nouns

The singular adjectives in the examples below exhibit two consonantal morphological morphemes, the geminated medial root consonant /b/ in the first and /t-/ as prefix in the second. The long vowels are the adjectival morphemes.

- (463)        /xabba:z/, ‘baker’                    /xabba:z-i:n/  
               /tanfi:ð/, ‘implementation’        /tanfi:ð-a:t/

These two adjectives qualify for SP because of the morpho-semantic features of the two morphemes. Geminating the medial root consonant denotes the intensity, extensity, and repetition of the action. This is always associated with VNs that designate profession. The prefixal morpheme /t-/ designates an associative meaning of the action which involves two (or more) parties, gradual and continuous movement,

or an increase in a quality. The two morphemes in the above examples refer to the actions and how they are done, and do not in any way refer to the doers of those actions. Thus, the function of the morphemes here is to express the processing of the activities within a constraint of time. The intensity of the action is expressed in /xabba:z/ by the geminated medial consonant, while in /tanfi:ð/ it is expressed by /i:/. /t-/ in /tanfi:ð/ expresses the associative meaning involving two or more parties. Consequently, such references to the action block these adjectives from qualifying to receive BP.

The derivational morphemes associated with Form VII adjectives behave in the same way. In the singular adjective /ʔinʔika:s/, there are two derivational morphemes denoting different actions. They are /n/ and /a:/:

(464)            /ʔinʔika:s/, 'reflection'            /ʔinʔika:s-a:t/

The morpheme /n/ designates many meanings of the action, such as reflexive, resultative, passive, and the action being done or happening oneself. The morpheme /a:/: designates the associative action, the repeated action, and the attempted action which are associated with Form III adjectives. Thus, these derivational adjectival morphemes express the multiple relations of the action among more than one party. In other words, the relation does not hold for the entities themselves but rather it holds for and reflects the action that affects these entities.

The morpheme /s/ in the follow representative example adds to and denotes special characteristics of the adjective:

(465)            /ʔistiʔda:d/, 'readiness'            /ʔistiʔda:d-a:t/

It denotes the process of the action which lasts for a long period of time. The meaning of the adjective signals that it designates the process of preparation which usually involves some procedural steps. In addition, the morpheme /a:/: designates the relation between multi-party processes involved in the action. In some adjectives, the

adjective, by its nature, designates the action without affixational derivational morphemes as in the following example:

(466)        /tɑðabðab/, ‘oscillation’        /tɑðabðab-a:t/

This quadrilateral adjective is formed by reduplicating the first two root consonants. As the adjective shows, there are no obvious adjectival morphemes. However, reduplicated forms in LA, and even in CA, usually express the intensity of the action. Consequently, this adjective is prevented from qualifying for receiving BP.

In the discussion of participles, many adjectives have been encountered that qualify for BP. Furthermore, we have observed that either the active participle morpheme /a: / or the passive participle morphemes /u: / are transferred to the output derived BP form. Although such morphemes are adjectival morpheme, they acquire the stable state of the noun since they designate the consistent characteristics of the entity and not the action done by this entity. However, participles may preserve their adjectival nature in such a way that they denote the action and the activity carried out by the entity. Such actions and activities are constrained by a limitation of the period of time involved. That is to say, the action denoted by the participle lasts only for a short period of time. Consider the examples in (b) and (c) below:

b. Active Participle

Active participle adjectives of the form /Ca:CiC/ qualify for many BP patterns such as /CaCa:CiC/ and /CuCaCa: ?/. Their qualification to receive BP is attributed to the fact that such adjectives have acquired some stable and long lasting characteristics associated usually with nouns. In some cases, the active participle does not qualify for BP, but rather it receives SP. Consider the example given below:

(467)        /sa:kin/, ‘resident’        /sa:kin-i:n/

In fact, this adjective has a BP form which is the medial geminated form /sukka:n /. The difference between the BP and SP forms reveals a difference between the noun

and the adjective. The BP form denotes the entities that live permanently in the residence, whereas the SP denotes the entities that currently and temporarily occupy.

Other constraints disqualifying the active participle from receiving BP can be attributed to the existence of adjectival morphemes which designate the state of the action and the parties involved in the action. Such morphemes, as discussed and explained in the discussion of verbal nouns in (a) above, are underlined in the following examples. It must be noted that the prefix /m-/ is the participle derivational morpheme, and since it does not contribute to the SP formation it is not underlined. The remaining consonants are the roots:

- (468) /munassiq/, ‘coordinator’                      /munassiq-i:n/  
           /mutaxassis/, ‘specialist’                      /mutaxas<sup>ʕ</sup>s<sup>ʕ</sup>is<sup>ʕ</sup>-i:n/  
           /mustamiʔ/, ‘listener’                              /mustamiʔ-i:n/  
           /mustawrid/, ‘importer’                            /mustawrid-i:n/

Because of these morphemes, the adjectives are explicitly connected to and express the actions. As mentioned previously, the adjective may denote the action without any affixational derivational morpheme. That is to say, the adjective describes and designates the sort of actions and processes, as in the following example:

- (469)        /muʃrif/, ‘supervisor’                      /muʃrif-i:n/

Although the participle morpheme /m-/ refers to the doer, this adjective designates the process of activities done by the doer. Thus, the sense of supervision designated by the adjective suggests that it denotes a temporary process of action. Even in some quadrilateral adjectives, what prevents the adjective from qualifying to receive BP is the designation of the action, as in the following example:

- (470)        /muhandis/, ‘engineer’                            /muhandis-i:n/



### c. Passive Participle

One of the differences between the active and passive participles is that the former usually denotes the doer of the action, while the passive participle usually denotes the receiver of that action. The action plays the main role in forming the passive participle. Consequently, the norm for the passive participle is to receive only SP and not BP, as in the following examples:

- (471)            /mandu:b/, ‘delegate’            /mandu:b-i:n/  
                  /muzallad/, ‘volume’            /muzallad-a:t/

It must be noted that there are cases when the passive participle adjective qualifies for BP. This is because such an adjective acquires the stable and permanent characteristics of the noun, as presented in section 6.2. To overgeneralize the qualification of an adjective to receive a plural form, we could say that the closer the adjective is to designating the action, the more likely it is to receive SP. In addition, the closer the adjective is to designating stable and permanent characteristics, the more likely it is to receive BP.

## 7.10 Overview of Constraints Interaction and Ranking

As has been arguing throughout this thesis, the input, which is the underlying structure of the derivational morphological process, is restricted and shaped by the components of the morphological process. When the input is processed in the phonological component, the creation of competing outputs is triggered by the interaction between the constraints of the language. On the one hand, morphological components seek faithfulness. Preservation of the consonantal roots and the derivational morphemes are governed, generally, by undominated constraints. This is related to the fact that if the identity of these morphological components is affected, then the morphological process is either lost or unidentified. Thus, these components must have input-output faithfulness relations. On the other hand, at the surface level, the phonological constraints seek phonological processing and structural modification to any output candidate. The first constraint to play the phonological role is

\*COMPLEX which has twofold function. It encourages syllabification of the morphological components and at the same time militates against any consonantal cluster which, as expected, may result from the morphological process. In this case, the phonology inserts epenthetic vowels where necessary to syllabify the morphological components:

\*COMPLEX >> DEP

Well-formedness of syllable structure in the language requires at least the filling of two syllable nodes, which are the onset and nucleus. The usual syllabification process is to fill the consonantal morphological morphemes e.i. the root consonants plus the consonantal derivational morphemes, in onset positions, and to fill vocalic derivational morphological morphemes in nucleus positions. When all the morphological components are positioned within syllable nodes, any unsyllabified segment or consonant cluster becomes subject to resyllabification by epenthesis processes where epenthetic vowels are inserted in order to create well-formed syllables. The general epenthetic vowel is /i/, however, it might be affected by a neighbouring environment, for example, vowel harmony, backness, in such a way that this vowel changes its features. The syllabification process seeks to parse segments with respect to binarity requirements. Syllables are parsed as bimoraic and feet are parsed in disyllabic structures. In some occasions and in restricted environment, the language allows a trimoraic syllable where the extra mora is licensed to be adjoined directly to the prosodic word.

The tendency of the language is to create as many heavy syllables as possible. The vowels of unstressed light syllables are usually omitted creating consonant clusters in the margins. To avoid such clusters, phonology repairs these consonants by augmenting them in new closed syllables:

\*Cv, \*CvCv, \*[Cv]<sub>σ</sub>, \*COMPLEX >>> MAX (VOWEL)

As far as onset filling is concerned, there are some constraints on the surface of glides, whether as root consonants or as derivational morphemes. For root consonants, if the morphological process identifies the glide as the head of an active

morphological site, then the glide surfaces with its consonantal features. Otherwise, if it is in the initial or the final position of the stem, that is the derived word, it becomes subject to restriction on its vocalic or consonantal features, or loses its features all together and acquires different features, and even deletion:

GLIDE=ONSET >> {I, U} = μ

The constraint NO-DIPH is ranked high. To satisfy this constraint, the features of glide has to undergo change and/or the inhomogeneous segments has to be combined in such a way the segments are positioned closer to the centre:

NO-DIPH, COMBINE {U, A} >> IDENT-FEATURE

For root consonants, any output produced by the derivational morphological process has to fulfil the minimality number of root consonants, that is the constraint \*2 CONSONANTS, and the maximality constraint \*5 CONSONANTS:

\*2 CONSONANTS >> DEP

\*5 CONSONANTS >> MAX-C

The long vowels are considered underlyingly as glides as demonstrated in many previous examples. When such long vowel coexist with four root consonants, in the derivation of the morphological process it is omitted all together. There are three markedness constraints responsible for the deletion. The preservation of the long vowel violates at least one of them:

\*4 SYLLABLES, ONSET, \*5 CONSONANTS >>> MAX-V-LONG

The overall picture of constraints interaction is expressed by two extreme sets of constraints. On the one side, faithfulness constraints of the morphological components seek preservation of identity at the surface. On the other side, phonological constraints seek to restructure these morphological components when they surface. The conflict between these constraints is compromised as long as the morphological components are preserved in the output, and the optimal output has the least violations to the hierarchy of the phonological constraints.

## 7.11 Conclusion

This chapter has argued against any complete correspondence relations between the stem singular form and the derived output BP form. The derivation of BP forms is shaped by the morphological processes of non-concatenative morphology. Deriving the BP form requires the restructuring of the corresponding source of derivation. As is the case for the derivation of nouns and adjectives, the morphological process of BP first strips the root consonants of the input and then inserts the derivational morphemes in the active morphological sites associated with the targeted BP type. Identifying the target BP morpheme, the associated host active morphological site and the input root consonants together structure the underlying form of the derived BP form. There are elements, however, carried over from the input which are preserved in the output. These elements are not phonological nature, but rather have a morphological and lexical nature. For example, the morpheme associated with the active participle is sometimes maintained in some BP forms. Also, the lexical nature of some adjectival forms is maintained as adjectives in the derived BP form. However, some adjectives acquired the lexical states of the noun and that explains why some input adjectives are associated with specific noun forms. When an output derived BP surfaces, we observe a diversity of morphological and phonological constraints which operate on it. Such diversity is triggered in most cases by the nature and the position of the derivational morphemes. Morphologically speaking, there are two morphological constraints associated with the derived word as far as the root consonants are concerned; the first is that the minimal number of root consonants is three, and the second is that the maximal number of root consonants is four. These two constraints are high-ranked in the language, and even loanwords have to respect them in order to qualify for BP.

The diversity of BP forms is in fact related to the richness of the derivational morphemes associated with BP. Each derivational BP morpheme carries a different meaning and consequently requires a different morphological process. This explains precisely why a singular form has multiple corresponding BP forms. In this case, the morphological process is not only morphologically motivated but is in fact morpho-  
semantically motivated. Thus, such derivational morphemes are supplied by either the

morphology or the semantics. In both cases, the derivational morphemes must be morphologically identifiable.

## Chapter 8: Summary and Conclusions

Throughout this thesis, a morphophonological account has been presented of the formation of the non-concatenative morphology of the nominal system of LA with special reference to the formation of BP. In addition, an OT account has been presented of all the morphological and phonological constraints related to the surfacing output candidates. The major contribution of this research is the identification of the underlying structure of the derivational morphological processes related to the derivation of the non-concatenative nominal system of LA. Reviewing previous studies which have investigated the non-concatenative morphology of BP in CA in Chapter two, it was revealed that all these studies fail to identify the exact derivational morphological process. Their failure to identify the morphological process leads them to mistakenly assume input-output relationships between segments of the input and those of the output. Consequently, the input of a BP derived word has never actually been identified. Since the non-concatenative morphological process of BP is similar to any non-concatenative morphological process in the nominal system of LA, the nature of the input of such morphological derivational processes was questioned (see section 2.8). Because of the interference of at least the two linguistic levels of morphology and phonology in the derivation of non-concatenative morphology in output words, this thesis has highlighted the importance of identifying the input for any derivational morphological process. The input turns out to involve the root consonants plus, in some cases, any morphological components related to the source of derivation along with the derivational morphemes of the intended morphological process.

The other contribution of the thesis is the identification of the nature of the underlying structure of the morphological process and how such identification can be worked out in an OT framework (see section 3.3). I think that the major problem in dealing with a morphophonological derivational process in OT concerns the nature of the input. That is to say, because OT is an output-oriented approach, it does not explain or justify the

nature of the relationship between the output and the input of non-concatenative morphological processes since it ignores the derivational morphological process and the other components of this process. It is shown to be the case that the string of root consonants and in some cases some morphological properties of the source of the derivation plus the derivational morphemes of the intended derivational process are the main components of any underlying structure. Thus, the nature of the input is shaped by these components. At the surface level, phonological constraints modify this input until the optimal output is achieved. One of the most important phonological constraints which first plays a role in modifying the underlying structure is the constraint \*COMPLEX. The function of this constraint is twofold: to militate against any margin complexity resulted from the morphological process and to encourage the syllabification of segments.

Accounting for the correspondence relations between the input and the output derived word, it is revealed in this thesis that there are no phonological elements, a part from the root consonants, standing in correspondence. The phonological structure of the input does not in any way contribute to the phonological structure of the derived output. The phonological constraints are in fact active at the surface level to modify any ill-formed structure resulting from the morphological derivational processes. In other words, the phonological constraints are a set of universal and language-specific constraints which are not in any way restricted to specific inputs or specific outputs. They are rather seen as constraints which seek the good formation of the output candidates. On the other hand, in a morphological derivational process, the morphology of the source of the derivation is distinguished from that of the derived word, although we have come across some cases where some morphological properties of the source of the derivation are carried over into the derived word. These may include the derivational morphemes of the active participle and the lexical derivational morphemes of adjectives. It is emphasized in this thesis that the morphological processes of non-concatenative morphology take place prior to any phonological process.

This represents exactly the borderline between the morphology and phonology of non-concatenative derived words. The intermediate relationship which holds between the input and the output derived word is a purely morphological relationship which is

motivated and supplied by the derivational morphemes of the intended morphological process. In addition, the structure of the underlying form of the derived word consists of the components of the morphological process of such derived words. Thus, unless the morphological process and its morphological components are identified, the motivation for the phonological processes cannot be justified or triggered.

Most of the work which has been carried out on the Arabic derivational system fails to recognize the actual morphological derivational processes and/or the precedence of the morphological over phonological processes. From the CA descriptive approach up to the prosodic morphology approach, the concept of the template plays the main role in derivational morphology. It has not previously been investigated why such templates exist. The derivational processes of the nominal system of LA show that the template is the result of the phonological constraints which operate on the structure which results from the derivational morphological processes. Furthermore, the diversity of templates associated with one underlying input is attributed to the interaction between morphology and phonology, as in /ʒabal/, ‘mountain’, and their two BP candidates /ʒiba:l/, and /ʔiʒba:l/, and/or morphology and semantics as in /tʕɑ:lib/, ‘student’, and their two BP candidates /tʕulla:b/, and /tʕɑlabat/. The difference between /tʕulla:b/ and /tʕɑlabat/ is morphosemantically constrained. The derivational morphemes of the two plural forms are distinct, and the difference between their meanings is also distinct. In /tʕulla:b/, the meaning denoted by the plural refers to the individuals within one group, while in /tʕɑlabat/ it is considered as a collective noun which refers to one group rather than referring to the individuals of that group. Although this thesis has focused on the morphophonological processes of the derivation of the non-concatenative nominal system of LA, the morphosemantics processes have been touched upon only briefly since the present researcher has only a limited knowledge of semantics. Thus, any future studies should focus more on morphosemantics, which could tell us more about the morphosemantic functions of the derivational morphemes.

As a generalisation, nouns qualify for BP. This is supported not only by the productivity of BP forms in nouns but also by the adjectives that qualify for BP. The



generalisation concerning adjectives is that they receive SP because of the unstable and temporary nature denoted by the adjective. However, if an adjective acquires the stable and permanent state of the noun, it qualifies for BP. In section 7.9, the qualification of an adjective to receive a plural form was attributed to the complex process of interaction between morphology, syntax, and semantics. For example, /nad<sup>ɛ</sup>i:f/ ‘clean’ has the MSP /nad<sup>ɛ</sup>i:fi:n/ and the BP /nd<sup>ɛ</sup>a:f/. In MSP form, the MSP suffix /-i:n/ denotes intensity of the action within a limited time; while the BP acquires the noun state by deleting the adjective morpheme and positioning the BP morpheme after C<sub>2</sub>, which is the usual process for nouns. The difference in meaning between the two plural forms is semantically governed. In addition, when this adjective qualifies for BP it changes its syntactic category to a noun. Section 7.9 has accounted for some morphosemantic constraints that disqualify a noun from qualifying to receive BP. Such constraints are governed by the meaning denoted by the derivational morphemes. The meanings of these derivational morphemes designate the relationship between two or more parties and/or the processes involved in activities. Thus, these derivational morphemes describe, as do adjectives, the action and not the entity. For example, /mustaʃfa:/, ‘hospital’, though the prefix /m-/ designates the noun of place, the morphemes /s/ and /t/ designate the activity of the actions. /s/ designates the intensive process of the action which lasts for some long time, while /t/ designates the reflexive and multi-party relations of the actions. Consequently, the existence of such morphemes prevents a word from acquiring the stable and permanent characteristics of the noun.

As far as non-concatenative morphology is concerned, the association of a derivational morpheme with an active morphological site is not sporadic. Observing the derivational morphemes of the nominal system of LA (see chapters five, six, and seven), it is revealed that each morpheme is hosted in a specific active morphological site identified by the morphological process itself. For example, the morpheme of the active participle is hosted immediately after C<sub>1</sub>, and BP morphemes are usually hosted immediately after C<sub>2</sub>. In some adjectives it happens that the BP morpheme is hosted after C<sub>3</sub>. This is related to the fact that these BP morphemes are phonetically identical to the adjectival morpheme (see sections 7.3.6 and 7.3.7). Since the lexical features of the nominal system surface as suffixes, the BP morpheme is forced to surface after C<sub>3</sub>

in order to compensate for the deletion of the adjectival morpheme, as in /ħ<sub>1</sub>ak<sub>2</sub>i :m<sub>3</sub>/, ‘wise man’ /ħ<sub>1</sub>uk<sub>2</sub>am<sub>3</sub>a :ʔ<sub>4</sub>/, ‘wise men’. However, the adjectival morpheme is phonetically omitted but lexically preserved since the BP morpheme functions as a plural marker and by its position as an adjectival marker. In other instances, we have seen that the multi-templates association with one underlying form can be attributed to the type of morphemes and/or the morphological or semantical motivation of the derivational process. In other words, the active morphological sites are activated by either a morphological and/or a morphosemantic process.

Identifying the actual derivational morphological processes and how the phonological constraints modify the derived non-concatenative nominal output, as put forward in section 3.3, has been applied in chapters five, six, and seven. The results confirm the research hypothesis stated in the introduction to this thesis. Thus, to justify the well-formedness of such derived words, the morphological process has to be identified first with all its morphological components, and then morphophonological constraints come into play at the surface level to well-form such derived words.

As pointed out on many occasions, this thesis is concerned with the morphophonological processes of the non-concatenative nominal system. Based on the present study’s findings, these are applied on BP formation in chapter seven. The diversity of BP patterns cannot be understood and justified by morphophonological processes only. Consequently, it has been difficult to construct a model to predict such BP patterns. This is mainly because BP formation makes reference to at least three linguistic levels of morphology, phonology, and semantics. Such predictability could be achieved if the semantic meanings and functions of the derivational morphemes were identified and their processes were understood.

In any future research in Arabic language, including CA and its dialects, it is recommended that a thorough investigation is carried on the derivational morphemes, both vocalic and consonantal. Their function and position in the active morphological sites would give more insight of the derivational morphological processes of the language. In addition, it would reveal the interaction between the linguistic levels. By doing so, the acquisition and/or learning of the language could be investigated in the light of activating the derivational morphemes in their host active morphological sites.

## References

- Abaas, Hasan. 1963. *Al-Nahw Al-Wafi*. Daar Al-Ma'arif: Cairo.
- Abd-Rabbo, M. Z. 1988. 'Sound Plural and Broken Plural Assignment in Classical Arabic' in M. Eid '(ed(s))' *Perspectives on Arabic Linguistics*. Papers from the Annual Symposium on Arabic Linguistics. John Benjamins Publishing Co., Amsterdam/Philadelphia. 55-93.
- Abdunnabi, Awad. 2000. *A Descriptive Grammar of Libyan Arabic: A Structural Method*. PhD, University of Exeter.
- Abumdas, Abdul Hamid. 1985. *Libyan Arabic Phonology*. PhD, University of Michigan.
- Al-Ageli, Hussein. 1996. *Syllabic and Metrical Structure in Tripolitanian Arabic: A Comparative Study in Standard and Optimality Theory*. PhD, University of Essex .
- Al-Aghbari, Khalsa. 2001. *The Broken Plurals in the Muscat Dialect of Omani Arabic*. Master of Arts, University of Victoria.
- Al-Hadithi, Khadija. 2003. *Abniyat Al-Sarf Fi Kitaab Sibawayh. (Morphological Forms in the Sibawayh's Kitaab)*. Maktabat Lebanon Nashiruun: Beirut.
- Al-Suhaibani, Al-Waleed . 2004. *Arabic Broken Plurals and Prosodic Circumscription: A Theoretical and Experimental Investigation*. PhD, University of Delaware.
- Al-Zoaby, Rema & E. Y. Mohammed. 2005. *Pluralization in English and Arabic: A Phonological Study*. Al-Tahadi University: Sirt. Unpublished work.
- Asfour, F. M. 2001. *Theoretische Aspekte Der Internen Pluralbildung Im Klassischen Arabisch*. PhD, Diplomarbeit zur Erlangung des Magistergrades, Universität Wien.
- Bakkuush, Al-Tayyib. 1987. *Al-Tasrif Al-Arabi. (Arabic Morphology)*. Mu'assasat Abdelkarim Bin Abdellah: Tunis.
- Bat-El, Outi. 1994. 'Stem Modification and Cluster Transfer in Modern Hebrew'. Natural Language & Linguistic Theory 12: 571-596.
- Bat-El, Outi. 2002. 'Semitic Verb Structure with a Universal Perspective' in J. Shimron '(ed(s))' *Language Processing and Language Acquisition in a Root-Based Morphology*. John Benjamins Publishing Company Amsterdam, Philadelphia: 29-59.

- Belnap, R. Kirk. 1999. 'A New Perspective on the History of Arabic: Variation in Marking Agreement with Plural Heads'. *Folia Linguistica*, 33: 169-185.
- Benua, Laura. 1995. 'Identity Effects in Morphological Truncation' in J. Beckman, L. W. Dickey, & S. Urbanczyk '(ed(s))' *Papers in Optimality Theory*. University of Massachusetts Occasional Papers in Linguistics 18 Amherst, Mass. Graduate Linguistic Student Association. 77-136:
- Benua, Laura. 1997. *Transderivational Identity: Phonological Relations between Words*. PhD, University of Massachusetts, Amherst. [ROA-259, <http://rucss.rutgers.edu/roa.html>].
- Benua, Laura. 2004. 'Transderivational Identity: Phonological Relations between Words' in J. McCarthy '(ed)' *Optimality Theory in Phonology*. Blackwell: 419-437.
- Brame, Michael. 1970. *Arabic Phonology: Implications for Phonological Theory and Historical Change*. PhD, Massachusetts Institute of Technology.
- Chomsky, Noam. 1965. *Aspects of the Theory of Syntax*. MIT Press: Cambridge, Mass.
- Chomsky, Noam & M. Halle. 1968. *The Sound Pattern of English*. Harper and Row: New York.
- Clements, George. 1990. 'The Role of the Sonority Cycle in Core Syllabification' in J. Kingston & M. E. Beckman '(ed(s))' *Papers in Laboratory Phonology I: Between the Grammar and Physics of Speech*. Cambridge University Press: 283-333.
- Clements, George. N. & S. Keyser. 1983. *Cv Phonology: A Generative Theory of the Syllable*. MIT Press: Cambridge, Mass.
- Elfitoury, Abubaker. 1976. *A Descriptive Grammar of Libyan Arabic*. PhD, Georgetown University.
- Elgadi, Abdalla. 1986. *Tripolitanian Arabic Phonology and Morphology: A Generative Approach*. PhD, Georgetown University.
- Erwin, W. M. 1963. *Short Reference Grammar of Iraqi Arabic*. Georgetown University Press: Georgetown.
- Farwaneh, Samira. 1990. 'Well-Formed Association in Arabic: Rule or Condition?' in M. Eid & J. McCarthy '(ed(s))' *Perspectives on Arabic Linguistics II. Papers from the Second Annual Symposium on Arabic Linguistics*. John Benjamins Publishing Company. 120-142:
- Fleisch, H. 1961. *Traité de Philologie Arabe, I: Préliminaires, Phonétique Morphologie nominale*. Imprimerie Catholique: Beirut.
- Fox, Joshua. 2003. *Semitic Noun Patterns*. Winona Lake: Eisenbrauns.

- Gadalla, H. 2000. *Comparative Morphology of Standard and Egyptian Arabic*. Munich: Lincom Europa.
- Goldsmith, John. 1976. *Autosegmental Phonology*. PhD, MIT.
- Goldsmith, John A. 1979. *Autosegmental Phonology*. Garland Pub: New York.
- Goweder, A., M. Poesio & A. De Roeck. 2004. 'Broken Plural Detection for Arabic Information Retrieval'. Paper presented at *Proceedings of the 27th annual international ACM SIGIR conference on Research and development in information retrieval, SIGIR, 2004*, pp.566-567.
- Greville, G. Corbett. 2000. *Number*. Cambridge University Press: Cambridge.
- Guerssel, M. & J. Lowenstamm. 1990. 'The Derivational Morphology of the Verbal System of Classical Arabic'. Ms, Université du Québec à Montréal, Université Paris 7.
- Guerssel, M. & J. Lowenstamm. 1996. 'Ablaut in Classical Arabic Measure I Active Verbal Forms' in L. Lowenstamm, J. & U. Shlonsky '(ed(s))' *Studies in Afro-Asiatic Grammar*. Holland Academic Graphics: The Hague.123-134.
- Halle, Morris & J. Vergnaud. 1987. *An Essay on Stress*. MIT Press: Cambridge, Mass.
- Hammond, Michael. 1988. 'Templatic Transfer in Arabic Broken Plurals'. *Natural Language & Linguistic Theory*, 6: 247-270.
- Harrama, Abdulgalil. 1993. *Libyan Arabic Morphology: Al-Jabal Dialect*. PhD, University of Arizona.
- Harris, J. W. 1983. *Syllable Structure and Stress in Spanish*. MIT Press.
- Hayes, Bruce. 1980. *A Metrical Theory of Stress Rules*. PhD, MIT. [Published 1985, New York: Garland.].
- Hayes, Bruce. 1982. 'Extrametricity and English Stress'. *Linguistic Inquiry*, 13: 227-276.
- Hayes, Bruce. 1989. 'Compensatory Lengthening in Moraic Phonology'. *Linguistic Inquiry*, 20: 253-306.
- Hayes, Bruce. 1995. *Metrical Stress Theory: Principles and Case Studies*. University of Chicago Press:
- Hayes, Bruce & M. Abad. 1989. 'Reduplication and Syllabification in Ilokano'. *Lingua*, 77: 331-374.
- Hoberman, R. 1988. 'Local and Long-Distance Spreading in Semitic Morphology'. *Natural Language & Linguistic Theory*, 6: 541-549.
- Hyman, Larry. 1985. *A Theory of Phonological Weight*. Dordrecht: Foris.

- Ibn Aqil, Abd Allah ibn Abd al-Rahman. 2005. *Sharh Ibn Aqil Ala Alfiyat Ibn Malik. Two Volumes*. Maktabat Dar Al-Turaath: Cairo.
- Ibn Jinni, Abu al-Fatih Uthman. 1954. *Sirr Sina`at Al-a`Irab*. Mustafá al-Babi al-Halabi: Egypt.
- Idrissi, Ali. 1997. 'Plural Formation in Arabic' in M. Eid & R. Ratcliffe '(ed(s))' *Perspectives on Arabic Linguistics: Papers from the Annual Symposium on Arabic Linguistics*. John Benjamins Publishing Company: Amsterdam/Philadelphia. 123-145.
- Ito, Junko. 1986. *Syllable Theory in Prosodic Phonology*. PhD, University of Massachusetts, Amherst. [Published 1988, New York: Garland.].
- Ito, Junko. 1989. 'A Prosodic Theory of Epenthesis'. Natural Language & Linguistic Theory, 7: 217-260.
- Jacobson, R. 1962. *Selected Writings 1: Phonological Studies*. Mouton: The Hague.
- Kager, René. 1989. *A Metrical Theory of Stress and Destressing in English and Dutch*. Walter de Gruyter.
- Kager, René. 1995. *The Metrical Theory of Word Stress*. Research Institute for Language and Speech, University of Utrecht: Utrecht.
- Kager, René. 1999. *Optimality Theory*. Cambridge University Press: Cambridge.
- Kaye, J. & J. Lowenstamm. 1984. 'De La Syllabicité' in F. Dell '(ed(s))' *Forme Sonore Du Language*. Hermann: Paris. 123-161.
- Kaye, Jonathan. 1989. *Phonology: A Cognitive View*. Lawrence Erlbaum: Hillsdale, N.J.
- Kenstowicz, Michael. 1994. *Phonology in Generative Grammar*. Blackwell: Oxford.
- Kihm, Alain. 2006. 'Non-Segmental Concatenation: A Study of Classical Arabic Broken Plurals and Verbal Nouns'. Morphology, 16: 69-105.
- Kiparsky, Paul. 1982. 'Lexical Morphology and Phonology' in I. S. Yang '(ed(s))' *Linguistics in the Morning Calm*. Hanshin: Seoul. 3-91.
- Kiparsky, Paul. 1985. 'Some consequences of Lexical Phonology'. *Phonology Yearbook*, 2:85-138.
- Kiparsky, Paul. 2003. 'Syllables and Moras in Arabic' in C. Féry & R. van de Vijver '(ed(s))' *The Syllable in Optimality Theory*. Cambridge University Press: Cambridge. 147-182.
- Kramer, Ruth. 2007. 'Non-Concatenative Morphology in Coptic' in K. Aaron & D. Teeple (Eds.) *Phonology at Santa Cruz 7*. Linguistics Research Center. Santa Cruz, CA.

- Leben, W. 1973. *Suprasegmental Phonology*. PhD, MIT.
- Levin, Juliette. 1985. *A Metrical Theory of Syllabicity*. PhD, MIT.
- Levy, Mary Mansnerus. 1971. *The Plural of the Noun in Modern Standard Arabic*. PhD, University of Michigan.
- Lowenstamm, Jean & K. Jonathan. 1986. 'Compensatory Lengthening in Tiberian Hebrew' in L. Wetzels and E. Sezer '(ed(s))' *Studies in Compensatory Lengthening*. Dordrecht: Foris. 97-132.
- Lowenstamm L. J. 1996. 'Five Puzzling Chaha Verbs: An Exercise in Practical Morphophonemics' in G. Hudson '(ed(s))' *Essays in Gurage Language and Culture*. Wiesbaden: Harrassowitz. 123-132.
- McCarthy, J. J. & A. Prince. 1990b. 'Foot and Word in Prosodic Morphology - the Arabic Broken Plural'. *Natural Language & Linguistic Theory*, 8: 209-283.
- McCarthy, J. J. 1982. 'Prosodic Templates, Morphemic Templates and Morphemic Tiers' in H. H. van der & N. Smith '(ed(s))' *The Structure of Phonological Representations*. Foris Dordrecht. 191-233.
- McCarthy, J. J. & A. Prince. 1986. *Prosodic Morphology*. University of Massachusetts, Amherst and Brandeis University, Waltham, Mass. [Annotated version 1996, issued as Technical report no. 32, Rutgers Centre for Cognitive Science.].
- McCarthy, J. J. & A. Prince. 1993a. 'Generalized Alignment' in G. E. Booij and J. van Marle '(ed(s))' *Yearbook of Morphology*. Dordrecht: Kluwer. 79-153.
- McCarthy, J. J. 1979. *Formal Problems in Semitic Phonology and Morphology*. PhD, MIT.
- McCarthy, J. J. 1981. 'A Prosodic Theory of Non-Concatenative Morphology'. *Linguistic Inquiry*, 12: 373-418.
- McCarthy, J. J. 1997. *Faithfulness and Prosodic Circumscription*. [Roa-201, [Http://Ruucs.Rutgers.Edu/Roa.Html](http://Ruucs.Rutgers.Edu/Roa.Html)].
- McCarthy, J. J. 2002. *A Thematic Guide to Optimality Theory*. Cambridge University Press: Cambridge.
- McCarthy, J. J. & A. Prince. 1993b. *Prosodic Morphology*. Rutgers Center for Cognitive Science: New Brunswick, N.J.
- McCarthy, J. J. & A. Prince. 1995. 'Faithfulness and Reduplicative Identity' in J. Beckman, L. W. Dickey & S. Urbanczyk '(ed(s))' *Papers in Optimality Theory*. University of Massachusetts Occasional Papers in Linguistics 18 Graduate Linguistic Student Association: Amherst, Mass. 249-384.

- McCarthy, J. J. & A. Prince. 1999. 'Faithfulness and Identity in Prosodic Morphology' in R. Kager, H. van der Hulst & W. Zonneveld '(ed(s))' *The Prosody-Morphology Interface*. Cambridge University: Cambridge.
- McCarthy, John. & Alan. Prince. (1990a). 'Prosodic Morphology and Templatic Morphology'. in Eid, Mushira & J. McCarthy '(ed(s))' *Perspective on Arabic Linguistics II*. Benjamins: Amsterdam. 1-54.
- Mitchell, T. F. 1975. *Principles of Firthian Linguistics*. Longman: London. 162-200.
- Mohammed, Monera, N. Mohammed & A. Khalifa. 2006. *Plural Affixation in English and Libyan Arabic: A Morphophonological Study*. Al-Tahdi University: Sirt.
- Mohanan, K. P. 1985. *Lexical Phonology*. PhD, MIT.
- Owens, Jonathan. 1984. *Short Reference Grammar of Eastern Libyan Arabic*. Otto Harrassowitz: Wiesbaden.
- Padgett, Jaye. 2008. 'Glides, Vowels, and Features'. *Lingua*, 118: 1937-1955.
- Prince, Alan. 1980. 'A Metrical Theory for Estonian Quantity'. *Linguistic Inquiry*, 11: 511-562.
- Prince, Alan & P. Smolensky. 2004a. *Optimality Theory*. Blackwell.
- Prince, Alan & P. Smolensky. 1993. *Optimality Theory: Constraint Interaction in Generative Grammar*. Rutgers University, New Brunswick & University of Colorado, Boulder. [To appear as Technical report no. 2, Rutgers University Centre for Cognitive Science. Cambridge, Mass: MIT Press.]
- Prince, Alan & P. Smolensky. 2004b. *Optimality Theory: Constraint Interaction in Generative Grammar*. Blackwell.
- Prince, Alan. 1983. 'Relating to the Grid'. *Linguistic Inquiry*, 14: 19-100.
- Pulleyblank, Douglas. 1986. *Tone in Lexical Phonology*. Reidel, Dordrecht.
- Ratcliffe, R. R. 1990. 'Arabic Broken Plurals: Arguments for a Two-Fold Classification of Morphology' in M. Eid & J. McCarthy '(ed(s))' *Perspectives on Arabic Linguistics II*. Papers from the Second Annual Symposium on Arabic Linguistics. John Benjamins Publishing Company: 94-119.
- Ratcliffe, R. R. 1998. *The "Broken" Plural Problem in Arabic and Comparative Semitic: Allomorphy and Analogy in Non-Concatenative Morphology*. John Benjamins Publishing Company.
- Rosenthal, Sam. 1997. 'The Distribution of Prevocalic Vowels'. *Natural Language & Linguistic Theory*, 15: 139-180.



- Rosenthal, Sam. 2006. 'Glide Distribution in Classical Arabic Verb Stems'. *Linguistic Inquiry*, 37: 405-440.
- Ryding, Karin. 2005. *A Reference Grammar of Modern Standard Arabic*. Cambridge University Press: Cambridge.
- Samirrai, Fadel. 2007. *Ma'ani Al-Abniya Fi Al-Arabia (the Meaning of Patterns in Arabic)*. Dar Omar: Aman.
- Schane, Sanford. 1984. 'The Fundamentals of Particle Phonology'. *Phonology Yearbook I*: 129-155.
- Selkirk, E. O. 1982. 'The Syllable' in H. H. van der & N. Smith '(ed(s))' *The Structure of Phonological Representation. Part 2*. Dordrecht: Foris. 337-383.
- Selkirk, E. O. 1984. *Phonology and Syntax: The Relation between Sound and Structure*. MIT Press: Cambridge.
- Selkirk, E. O. 1981. 'Epenthesis and Degenerate Syllables in Cairene Arabic' in H. Borer & Y. Aoun '(ed(s))' *Theoretical Issues in the Grammar of Semitic Languages*. MIT: Cambridge. 111-140.
- Sibawayh, Amr ibn Uthman. 1999. *Al-Kitaab*. Dar Al-Kutub Al-Alimiyah: Beirut.
- Spencer, Andrew. 1991. *Morphological Theory : An Introduction to Word Structure in Generative Grammar*. Blackwell: Oxford.
- Steriade, Donca. 1988. 'Reduplication and Syllable Transfer in Sanskrit and Elsewhere'. *Phonology*, 5: 73-155.
- Tucker, Matthew. 2011. 'Iraqi Arabic Verbs: The Need for Roots and Prosody' in M. Washburn, K. McKinney-Bock, E. Varis, A. Sawyer & B. Tomaszewicz (Eds.) *Proceedings of the 28th West Coast Conference on Formal Linguistics*. Somerville, MA, USA, Cascadilla Proceedings Project.
- Ussishkin, A. 2000. *The Emergence of Fixed Prosody*. PhD, UC Santa Cruz.
- Ussishkin, A. 2006. 'Affix-Favored Contrast Inequity and Psycholinguistic Grounding for Non-Concatenative Morphology'. *Morphology*, 16: 107-125.
- Ussishkin, A. 1999. 'The Inadequacy of the Consonantal Root: Modern Hebrew Denominal Verbs and Output-Output Correspondence'. *Phonology*, 16: 401-442.
- Watson, Janet. 2002. *The Phonology and Morphology of Arabic*. Oxford University Press: Oxford.
- Wehr, Hans & J. Milton. 1961. *A Dictionary of Modern Written Arabic*. Harrassowitz: Wiesbaden.
- Wright, William. 2005. *A Grammar of the Arabic Language*. Dover Publications, INC: New York.

Yip, Moria. 1988. 'Template Morphology and the Direction of Association'. Natural Language & Linguistic Theory, 6: 551-577.

## Appendix: List of OT Constraints

\*[ʔ]

A glottal stop is prohibited.

\*ʔ]<sub>STEM</sub>

A glottal stop is prohibited stem-finally.

\*AFFIX+AFFIX

Two affixes must not be parsed within the same syllable.

ALIGN (HD-FT, RIGHT, PRWD, RIGHT)

Every prosodic word ends in a head foot.

Align (FT, RIGHT, PRWD, RIGHT)

Align the right edge of the stem with the left edge of the affix. (The affix is identified as a suffix.)

ALIGN (STEM-L, AFFIX-R)

Align the left edge of the stem with the right edge of the affix. (The affix is identified as a prefix.)

\*[- back]

Back vowels must be fronted.

\*CODA

A syllable must not have coda.

COMBINE {U, A}

Combine the features of {U} with the features of {A}.

\*COMPLEX

No complex syllable margins.

\*<sub>2</sub>CONSONANTS

The minimal root consonants must not be less than three in a derived word.

\*<sub>5</sub> CONSONANTS

In a derivational morphological process, root consonants must not exceed five.

\*[Cv]<sub>σ</sub>

Open light syllables are prohibited.

\*CV

Light syllables are prohibited.

\*CV:C-MEDIAL

Superheavy syllables are not allowed word-medially.

\*CVCC

Superheavy syllables are prohibited.

\*CvCv

A sequence of light syllables is prohibited.

DEP

Segments of the output must have input correspondents.

DEP-IO

Output segments must have input correspondents.

DEP<sub>OO</sub> (seg)

Every segment in Output<sub>2</sub> has a correspondent in Output<sub>1</sub>.

DEP<sub>OO</sub> (μ)

Every mora in Output<sub>2</sub> has a correspondent in Output<sub>1</sub>.

DEP-μ

Output moras must have input correspondents.

\*DIPH

Diphthongs are prohibited.

\*DOUBLE-MARKING

Derivational morphemes which mark grammatical categories must not assign a grammatical category more than once in any derived word.

FINAL-C

A stem is consonant-final.

FT-BIN

Feet are binary under moraic or syllabic analysis.

GLIDE ⇒ [ʔ]

A glide must surface as a glottal stop.

GLIDE-FRONTING

A glide must be fronted in a morphological derivational process.

GLIDE=ONSET

A glide must surface as a consonant.

GRWD = PRWD

A grammatical word must be a prosodic word.

\*GLIDE]<sub>STEM</sub>

A glide in stem-final position is prohibited

HARMONY

Vowels must be in harmony.

/i/ (FINAL SYLLABLE)

Final syllable must be /i/.

IDENT

All the identity features of the input must be preserved in the output.

IDENT-C

The identity features of the consonant must be preserved.

IDENT-F

The identity of the features must be preserved.

IDENT-IO

Correspondent segments in input and output have identical values.

IDENT-IO (Front)

Frontness identity of input must surface in the output.

IDENT-V

The identity features of the vowels of the input must be preserved in the output.

{I, U} =  $\mu$

Vocalic elements of {I} and {U} are moraic.

LICENSE- $\mu$

All moras must be licensed by syllables.

MAX

Segments of the input must have output correspondents.

MAX- $\mu$

Input moras must have output correspondents.

MAX<sub>OO</sub> (seg)

Every segment in Output<sub>1</sub> has a correspondent in Output<sub>2</sub>.

MAX<sub>OO</sub> ( $\mu$ )

Every mora in Output<sub>1</sub> has a correspondent in Output<sub>2</sub>.

MAX-IO

Every segment of the input has a correspondent in the output.

MAX- {U}

Every feature of {U} in  $S_1$  has a correspondent in  $S_2$ .

MAX- {A}

Every feature of {A} in  $S_1$  has a correspondent in  $S_2$ .

MAX {I}

Every feature of {I} in  $S_1$  has a correspondent in  $S_2$ .

MAX-C

Each consonant of the input must have output correspondent.

MAX-V-LONG

No long vowel shortening.

MAX-V-STEM

Each vowel of the input stem must have output correspondent.

NO-DIPH

No syllable contains a bivocalic nucleus.

NO-DELINK<sub>OO</sub> ( $\mu$ , seg)

Reassociation of moras or segments is prohibited.

NONFNALITY

No foot is final in PRWD.

NO-SPREAD<sub>OO</sub> ( $\mu$ , seg)

Spreading of moras or segments is prohibited.

OCP

No identical adjacent autosegments.

ONSET

Syllables must have onsets.

PARSE-SYL

Syllables must be parsed by feet.

\*PREFIX+ROOT

A prefix must not be syllabified with a root consonant.

RAISE [u]

The vocalic features of [u] must be raised.

RHTYPE = T

Feet have initial prominence.

#### RIGHTMOST

Stress falls on the rightmost syllable.

#### SEPARATE- MORPHEME

Infix morphemes must be parsed in separate syllables.

#### SON-SEQ

Complex onsets rise in sonority, and complex codas fall in sonority.

#### STRESS

Stress must be assigned.

#### \*4 SYLLABLES

The maximum allowed syllables is four.

#### \*TRIMORAIC

A sequence of trimoraic weight is not allowed.

#### \*[u+i]

Back and front vowels do not coexist within one syllable.

#### \*[uj]

A sequence of [u] and [j] do not coexist within the same syllable.

#### \*<sub>v</sub>-G-<sub>v</sub>

A glide does not surface if it is preceded and followed by two vowels at the same time.

#### \*V:]<sub>STEM</sub>

Long vowels are prohibited stem-finally.

#### -VV]<sub>STEM</sub> FRONTING

Long vowels must be fronted stem-finally.

#### \*-vv]<sub>STEM</sub> [BACK]

The quality of long vowel in stem-final position must be back.

#### \*/vvv/

A sequence of three vowels is prohibited.

#### \*[w\_ ]<sub>STEM</sub>

The glide [w] must not surface as an onset within the stem.

#### WSP

Heavy syllables are stressed.

#### \*[j]<sub>STEM</sub>

The glide [j] is not allowed stem-finally.