



Durham E-Theses

Using discrete event simulation for scheduling and long range capacity planning of a high volume press shop

Custance, Lucie Jane

How to cite:

Custance, Lucie Jane (2005) *Using discrete event simulation for scheduling and long range capacity planning of a high volume press shop*, Durham theses, Durham University. Available at Durham E-Theses Online: <http://etheses.dur.ac.uk/3107/>

Use policy

The full-text may be used and/or reproduced, and given to third parties in any format or medium, without prior permission or charge, for personal research or study, educational, or not-for-profit purposes provided that:

- a full bibliographic reference is made to the original source
- a [link](#) is made to the metadata record in Durham E-Theses
- the full-text is not changed in any way

The full-text must not be sold in any format or medium without the formal permission of the copyright holders.

Please consult the [full Durham E-Theses policy](#) for further details.

Academic Support Office, Durham University, University Office, Old Elvet, Durham DH1 3HP
e-mail: e-theses.admin@dur.ac.uk Tel: +44 0191 334 6107
<http://etheses.dur.ac.uk>

University of Durham
School of Engineering



Lucie Jane Custance

**Using Discrete Event Simulation for Scheduling and Long
Range Capacity Planning of a High Volume Press Shop**

MSc Thesis

A copyright of this thesis rests with the author. No quotation from it should be published without his prior written consent and information derived from it should be acknowledged.

2005

This thesis is submitted to the University of Durham in partial fulfilment of the requirements for the degree of Master of Science.



17 JAN 2006

Table of Contents

Table of Contents	ii
List of Figures	vi
List of Tables	vii
Abstract	viii
Acknowledgements	ix
Declaration	x
Nomenclature	xi
1 INTRODUCTION	1
1.1 RESEARCH AIM	3
1.2 RESEARCH OBJECTIVES	3
1.3 RESEARCH OUTLINE	5
1.4 PROJECT OUTLINE.....	7
1.5 DISCRETE EVENT SIMULATION	8
1.5.1 The Importance Of Simulation To Lean Manufacture	8
1.6 THE INDUSTRIAL NEED	10
1.6.1 Automotive Sector Facts And Figures	11
1.6.2 Mergers And Over Capacity	11
1.6.3 Key Factors To Remain Competitive In The Automotive Industry.....	12
1.6.4 Facility Layout Constraints.....	12
2 LITERATURE REVIEW	14
2.1 INTEGRATION OF DES WITH DESIGN FOR X (DRX), LIFE CYCLE ANALYSIS (LCA) AND OTHER PRODUCT DESIGN TECHNIQUES	14
2.1.1 Digital Enterprise Technology	14
2.1.2 The Early Design Stages	16
2.1.3 Concurrent Design And Life Cycle Management.....	17
2.1.4 Design For X.....	21
2.1.5 Product Data Management.....	24

2.1.6	Knowledge Management	25
2.1.7	Analysis Of Findings	26
2.2	SIMULATION	28
2.2.1	What Is Simulation?	28
2.2.2	Elements Of A Simulation Study	30
2.2.3	Usage Of Simulation	33
2.2.4	Simulation Surveys	34
2.2.5	Introducing Simulation Into Factories	35
2.2.6	Simulation Compared To Manual Or Spreadsheet Methods	37
2.2.7	Alternatives To Simulation	38
2.2.8	Types And Uses Of Simulation Software	38
2.2.9	Discrete Event Simulators	39
2.2.10	Des Terminology	40
2.2.11	Simulation Optimisation	41
2.2.12	Animation	42
2.2.13	Model Complexity	43
2.2.14	Schedules	44
2.2.15	Modelling Approaches	44
2.2.16	Product Mix	45
2.2.17	Verification And Validation Of Simulations	45
2.2.18	Conclusion	49
3	DEVELOPMENT OF SCHEDULING MODEL AND IDENTIFICATION OF SYSTEM REQUIREMENTS	51
3.1	INTRODUCTION	51
3.2	REQUIREMENTS CAPTURE	51
3.2.1	User Requirements	51
3.2.2	System Requirements	53
3.2.3	Prioritisation Of Areas To Be Investigated	53
3.3	THE INDUSTRIAL ENVIRONMENT	54
3.4	EVALUATION OF N Muk SCHEDULING PROCESS	56
3.4.1	Planning For Mass Customisation	56

3.4.2	Proposed Short Term Schedule System.....	56
3.4.3	Conclusions Of Analysis	59
3.5	SIMULATION SOFTWARE SELECTION AND BENCHMARKING	59
3.5.1	Functionality Requirements	60
3.5.2	Software Package Evaluation	61
3.5.3	Conclusion	63
4	BUILDING SIMULATION MODELS OF FLOW LINES FOR VALIDATING SCHEDULES AND LONG RANGE PLANNING	65
4.1	INTRODUCTION	65
4.2	PROBLEM FORMULATION.....	67
4.2.1	Setting Of Objectives And Overall Project Plan	67
4.3	MODEL CONCEPTUALISATION	68
4.3.1	Assumptions	69
4.3.2	Constraints	70
4.4	MODEL TRANSLATION	71
4.4.1	Data Collected	72
4.4.2	Obsolete Data.....	73
4.4.3	Model Entities	74
4.4.4	Building Large Models	81
4.4.5	Model Verification	83
4.5	MODEL VALIDATION AND USE.....	84
4.5.1	Validation	84
4.5.2	Downloading Production Run Data.....	85
4.6	CONCLUSION.....	86
5	EXPERIMENTATION AND RESULTS	87
5.1	INTRODUCTION	87
5.2	EXPERIMENTAL DESIGN.....	88
5.3	PRODUCTION RUNS AND ANALYSIS.....	88
5.3.1	Inventory Reduction.....	88
5.3.2	Results Of Inventory Experiments	90
5.4	MORE RUNS - WHAT IF SCENARIOS	91

5.4.1	Scenario 1	92
5.4.2	Scenario 2	102
5.4.3	Scenario 3	105
5.5	IMPLEMENTATION AND EXPECTED BENEFITS	108
6	FUTURE WORK AND CONCLUSIONS	109
6.1	ACHIEVEMENT OF MAJOR GOALS AND OBJECTIVES	109
6.1.1	Model Of The Press Shop	109
6.1.2	Increased Communication	110
6.1.3	Awareness Of Des / Det	111
6.2	HOW THE MODEL AND WITNESS FIT IN WITH NMUK SYSTEMS	111
6.3	LIMITATIONS OF THE SIMULATION	112
6.4	FUTURE WORK.....	113
6.5	CLOSING REMARKS	114

List of Figures

Figure 1-1 Types of simulation cases	1
Figure 1-2 Project Flowchart	7
Figure 2-1 Digital Enterprise Technology Framework	16
Figure 2-2 Comparison of modifications made in Japan and the West	19
Figure 2-3 Percentage reduction because of DFX	22
Figure 2-4 Flow through DFX, Boothroyd and Dewhurst	23
Figure 2-5 Law's approach to Modelling (Law 2001)	30
Figure 2-6 Centeno and Carrillo's Modelling Technique	32
Figure 2-7 Perera's (2002) fishbone diagram	36
Figure 2-8 Process Models (Smith and Peters, 1996)	40
Figure 2-9 Model Validity	46
Figure 2-10 Relationship between User Value and Confidence	47
Figure 3-1 DET framework for the press shop model	52
Figure 4-1 Research Methodology	66
Figure 4-2 Laser Match Condition	76
Figure 4-3 Parts going below safety levels	77
Figure 4-4 Parts going over maximum levels	78
Figure 4-5 Number of parts in the buffer	79
Figure 5-1 Offset charts for Inventory Reduction Exercise	90
Figure 5-2 Scenario 1 Offsets	93
Figure 5-3 Revised Offset charts for Scenario 1	97
Figure 5-4 Final offset table Scenario 1	97
Figure 5-5 Offset chart for Scenario 2	103
Figure 5-6 Scenario 3 Offsets	105
Figure B-6-1 Simulation Questionnaire	134

List of Tables

Table 2-1 Areas for investigation with simulation	34
Table 3-1 Software Selection Matrix.....	64
Table 4-1 Model Validation Table.....	85
Table 5-1 GIR Targets.....	89
Table 5-2 What If Scenarios	92
Table 5-3 Inventory table for Scenario 1.....	93
Table 5-4 Capacity Table for Scenario 1	94
Table 5-5 Revised Capacity Chart for Scenario 1.....	95
Table 5-6 Final Capacity chart for Scenario 1	98
Table 5-7 Final Inventory table for Scenario 1	99
Table 5-8 Inventory table for lower ED volume Scenario 1.....	100
Table 5-9 Offset tables for lower ED volume	100
Table 5-11 Inventory and Offset table for Scenario 2	102
Table 5-12 Capacity table for Scenario 2	103
Table 5-13 Comparison to wk 28 offsets	106
Table 5-14 Inventory analysis for Scenario 3	106
Table 5-15 Capacity chart for Scenario 3	107

Abstract

The thesis expresses the essential requirement for and the use of Discrete Event Simulation (DES) in a high volume press shop. The press shop produces blanks and panels for the body shop, which manufactures three car models. DES is used to combat the battle between shop efficiency and low inventory.

The process used to choose the most appropriate software package is described and then current situation in the press shop is discussed. The procedures involved in model creation follow set model construction guidelines. There are several assumptions made, which together with the constraints of the system, provide the limitations of the inputs facing the system. There is a trade off between model complexity and accuracy, so the setting of the constraints and assumptions often provided difficult decisions.

Validation of the model is very important, so this was a lengthy process, involving using a series of dummy buffers to check inputs such as cycle times and batch quantities. The validated model is used to monitor the methods used to reduce inventory on the shop floor over a period of eight weeks and then used for 'What If? Scenarios, to ascertain the systems capacity and inventory levels under different conditions. The scenarios include using volumes that are 100% higher on some models than the current situation and 20% less than currently. The findings are examined and proposals made for the introduction of the proposed volumes where possible. Findings of the scenarios highlight bottlenecks in the shop and areas for improvement. Using the model, the schedules can be changed quickly and easily to try and eliminate the bottlenecks and improve capacity.

Conclusions discuss the problems encountered during the modelling process as well as the benefits. The integration of DES into the current scheduling processes in the shop poses no problems and the model will be used as an aid for capacity planning in the future.

Acknowledgements

The author would like to thank the following people for their support, knowledge and advice throughout this research; Nick Toes, Trevor Smith and Steve Balding as well as other members of Production Control and Production at NMUK. Professor Paul Maropoulos, David Bramall and the Agility Group from the University of Durham.

Declaration

I confirm that no part of the material offered in this thesis has previously been submitted by me for a degree in this or any other university. This thesis presents the author's own work, except where appropriately acknowledged citations are given. Where material has been generated through joint work, my independent contribution has been clearly indicated.

The copyright of this thesis rests with the author. No quotation from it should be published without their prior written consent and information derived from it should be acknowledged.

Nomenclature

BoM	Bill of Materials
CAD	Computer Aided Design
CAE	Computer Aided Engineering
CAM	Computer Aided Manufacture
CAPE	Computer Aided Production Engineering
CAPP	Computer Aided Process
CIM	Computer Integrated Manufacture
CT	Coil Threading
DES	Discrete Event Simulation
DET	Digital Enterprise Technology
DFE	Design for Environment
DFMA	Design for Manufacture and Assembly
DFS	Design for Service
DFSS	Design for Six Sigma
DFX	Design for X
ED	Nissan Primera
GIR	Global Inventory Reduction
GPP	General Purpose Programming Language
GPSS	General Purpose Simulation Languages
HM	Nissan Tino
HS	Nissan Almera
JIT	Just In Time
KBE	Knowledge Based Engineering
LCA	Life Cycle Analysis
MDC	Manual Die Change
MM	Nissan Micra
MRP	Materials Requirements Planning
NMUK	Nissan Manufacturing UK
PDM	Product Data Management

QC	Quality Check
QFD	Quality Function Deployment
SMMT	Society of Motor Manufacturers and Traders
SNP	Standard Number of Parts

1 Introduction

If used effectively, Discrete Event Simulation can offer companies a competitive advantage in scheduling, capacity planning and other benefits including a reduction in system bottlenecks. This leads to reduced time to market and reduced operational costs. The Automotive industry is particularly competitive due to the saturation of vehicles in the market. Any competitive edge that a company can get in terms of cost and efficiency would be highly desirable. Many automotive manufacturers have been quick to realise this, with companies like Ford, BMW, Nissan and Rover all employing simulation to improve their business performance.

There are several different types of manufacturing environments that simulation can be used within. From one off projects, through to batch jobs such as Job shop or Flexible Manufacturing Systems (FMS) and Group Technology, and then Flow systems. Figure 1-1 shows the relationship between the variety and volume and the type of environment that it is most common in.

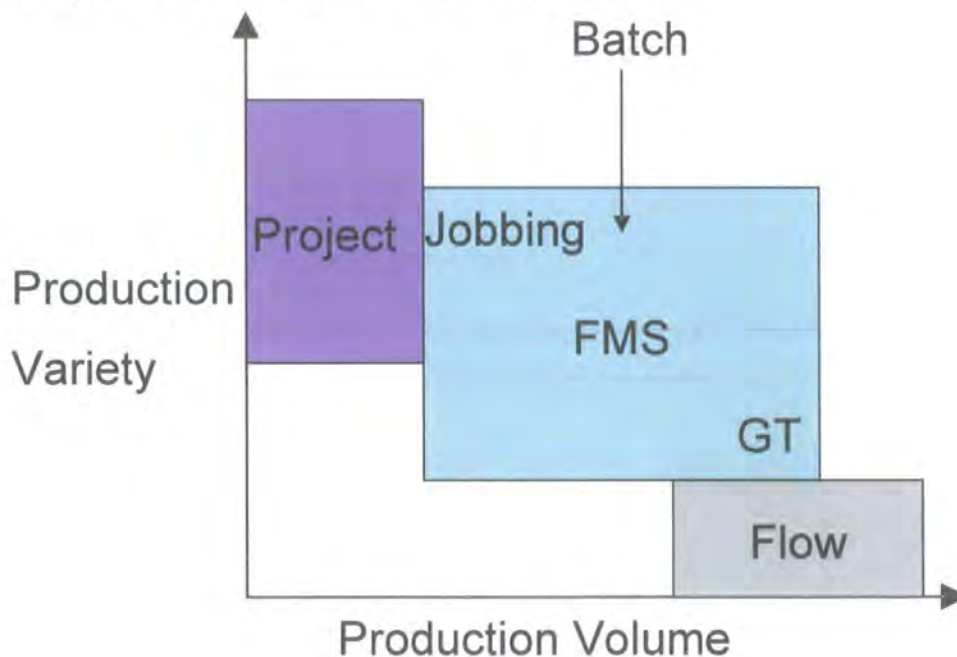

Figure 1-1 Types of simulation cases

INTRODUCTION

Simulation is used for all of these sectors and if designed at the right level of complexity, could be a major factor in the introduction of new products, processes and scheduling techniques. This research concentrates on a flow production system in an automotive press shop where material is worked through a set series of processes to manufacture press panels. These are permanent, dedicated lines in a brown field site and are not used for any other purpose.

Nissan Motor Manufacturing UK (NMUK) is based in Sunderland, UK and employs 4300 staff. It is the most productive car plant in Europe, but is constantly striving to maintain its position and improve productivity whilst reducing costs. The plant currently manufactures three models of car, the Micra, the Almera and the Primera. The Press Shop also presses panels for other plants and service parts.

The plant, and Nissan as a whole, underwent a period of losses and subsequent redundancies in the late 1990's, but with a re-branding exercise, revival plans, new vehicles and an alliance with Renault, the business has returned to profit. This research will examine how simulation is used at the plant and areas for future projects are identified.

A Digital Enterprise Technology framework is a new idea that encompasses simulation and provides feedback loops to all areas of design and maintenance of products and processes. The effectiveness of this framework is assessed throughout this research and the benefits of its use are explored.

The research described herein deals with the need for improvements of the long and short-term capacity planning of the Press Shop. The Press Shop is at the start of the car manufacturing process and supplies the Body Shop with the inner and outer panels for all three vehicles. Prior to this research, capacity planning was performed using spreadsheets, which took a long time to update and disseminate the results into a user-friendly format. This was perceived to be inflexible and required high levels of operator knowledge. Due to constraints imposed by the spreadsheet it was not known if optimal schedules were being produced. It was

also desirable to be able to carry out "What If" scenarios for proposed future schedule changes.

With production demands on the shop increasing, the inventory and efficiency targets were becoming more difficult to attain with the existing capacity planning tools. It was, therefore, proposed that a Discrete Event Simulation (DES) of the Press Shop could be created. DES is already used in other departments of the company and across the manufacturing sector, however for the purposes of planning in the Press Shop, new links between DES and dynamic stock control systems would need to be created.

1.1 Research Aim

The aim of this research is to produce a fully functioning Discrete Event Simulation (DES) model of a high volume press shop and deploy it using the principles of Digital Enterprise Technology (DET) to improve efficiency and scheduling in a high volume press shop. The model must be easy to use, even by those not trained in DES, via a user interface and generic output templates. The model shall be used to predict the outcomes of various 'What If?' scenarios imposed by the user. The importance of continuous production in the Press Shop means that the verification and validation of the simulation, prior to full roll out, are of paramount importance to the research.

1.2 Research Objectives

The main objective of the research is to show the advantages of using a Discrete Event Simulation software package to create a model of the press shop. This involved

1. To assess DES tools and select the most appropriate for the Press Shop model.
2. To create a model of a complex press shop using the chosen software package.

INTRODUCTION

3. To demonstrate the deployment of the DES model for planning and optimising the flow of work through a press shop and use it for capacity planning.
4. To utilise the DES model for "What If" scenarios and draw appropriate conclusions regarding planning and configuration of work through the real system.
5. To validate the model using real data for a week's schedule.

Forecasting of the blank and press lines and assessing the inventory holding and lead times against volume and mix changes is done with a spreadsheet, which is proving to be laborious and time consuming, using a lot of often inaccurate assumptions. The need for more accurate and reliable outputs means that the simulation model is essential for running the shop to better levels of efficiency. The research has involved the initial research and analysis of a variety of Discrete Event Simulation Software packages available. This analysis leads to the justification of and training of the key user in the chosen software package. Working in the Press Shop environment has provided the author with the background knowledge to model an accurate representation of the Press Shop and allow realistic schedules to be drawn from it on a regular basis.

By enhancing the analytical and forecasting methods used in the shop, the model was used to;

- Assess the press shop's current operating schedule.
- Produce a more optimised schedule solution to supply the body shop and other customers' demand.
- Keep inventory stocks to a minimum. These are governed by the targets set by the Global Inventory Reduction plans, which are produced for all the Nissan plants around the world by a team in Japan.
- Provide the ability to carry out 'What if?' scenarios reflecting possible shop capacity disruptions or future volume change plans.

The research must also provide a suitable implementation plan for deploying any new scheduling systems into the plant. This includes specifying methods and procedures for using and updating the model and training key users.

1.3 Research Outline

Figure 1-2 shows the methodology followed in this research. This thesis will determine the steps required to create and implement a simulation model of a high volume Press Shop.

To begin the research it was necessary to understand the Press Shop environment and the current procedures and processes. The Literature Review highlights areas that could be used to improve performance in the press shop and show what design and modelling techniques would have the most positive impacts. Short new model lead times are very important to survive in such a fast moving manufacturing sector and the methods used to reduce them most effectively are explored. The Literature Review also offers a more detailed insight into the need for simulation in today's businesses, from new factory design and redesign through to scheduling issues.

Chapter 3 describes the modelling process undertaken and discusses problems in simulating flow lines and their solutions. More detailed documentation of the models can be found in Appendix F.

Since, there are many Discrete Event Simulation software packages on the market, a detailed survey and benchmarking exercise was carried out, the results of which are shown in Section 3.5. The chosen software package for the research was Witness. In brief this is because it fulfilled all of the criteria and was seen by other more experienced users as the easiest to use with the most support offered from the supplier.

INTRODUCTION

A very important part of modelling is testing and verification of the results that are coming out of the model. Detailed testing and validations are presented in Section 4.4.5 and their importance is discussed in Section 4.5.

1.4 Project Outline

Below is the methodology followed throughout this research.

Figure 1-2 Project Flowchart

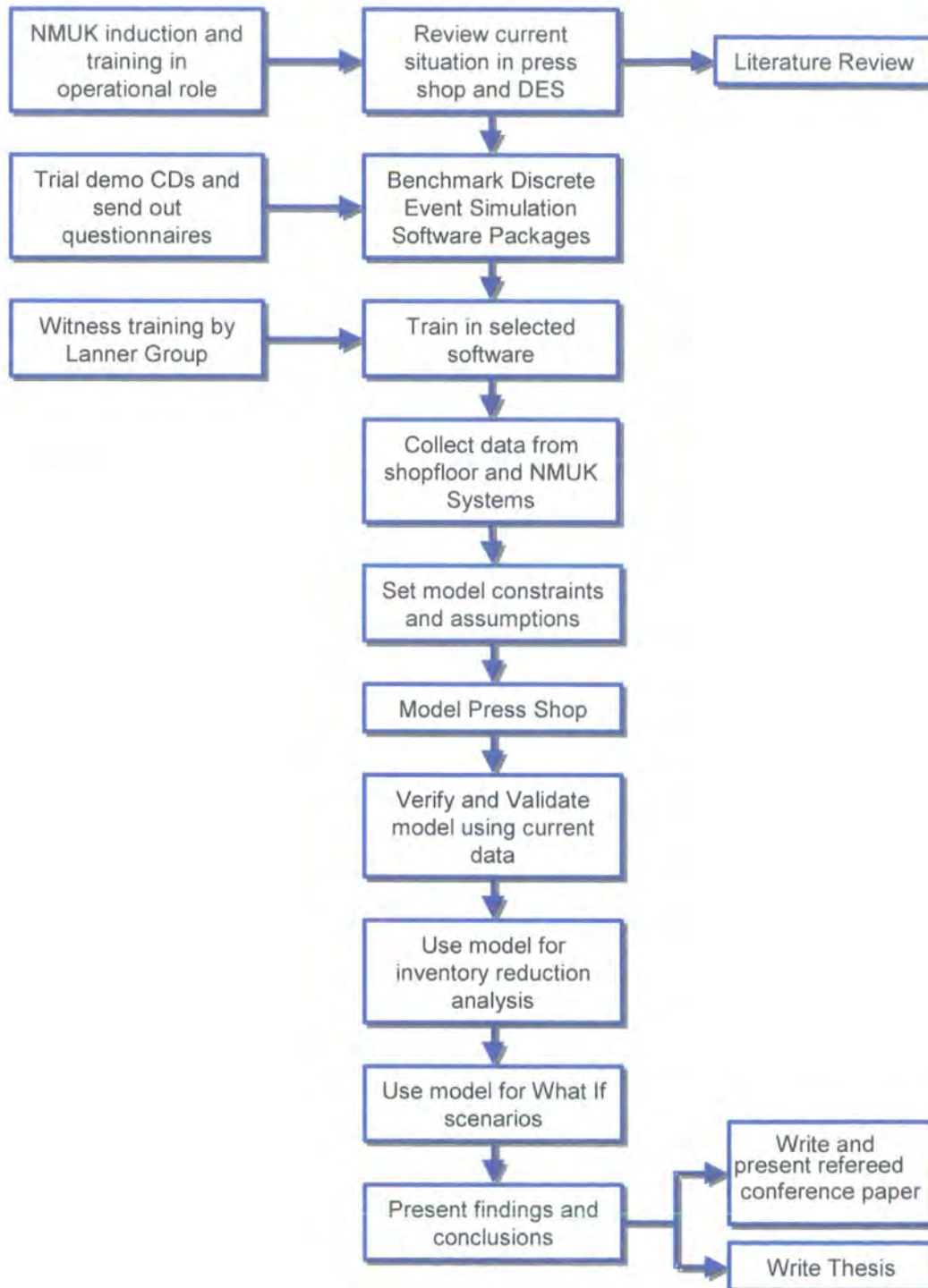

1.5 Discrete Event Simulation

Discrete Event Simulation (DES) is a modelling technique that is used world-wide by companies trying to improve competitiveness and reduce costs. It is used in both the service and manufacturing sectors and its advantages have been proven by high volume manufacturers, such as Nissan, and by suppliers of one-off components or small batches, such as Astrium satellites, as vital components for success. There are many DES software packages on the market. Models incorporating DES are used for scheduling, capacity planning and identifying bottlenecks within a system. DES models are dynamic with events happening at defined times. User-defined logic in the software allows the model to predict the sequence of events. Many of the major automotive manufacturers use DES to stay at the top of a very competitive market.

1.5.1 The Importance of Simulation to Lean Manufacture

A very important transition for all companies and one that has been implemented in the automotive industry is the move from mass production to lean manufacture. It was an idea first embraced by the Toyota Company in Japan, providing them with the means to provide a wider range of vehicles in smaller batches in order to supply to demand. A 5-year study of lean manufacture best practice was undertaken by the Massachusetts Institute of Technology by Jones, Womack and Roos (1991).

Henry Ford successfully introduced mass production in the early 20th century by introducing the standardisation and interchangeability of parts, tools and gauges. He made it possible for unskilled and semi-skilled workers to repeatedly produce a high quality vehicle for the time. Prior to this craft production and the assembly of parts from several non standard suppliers meant that no two vehicles were the same and had to be put together by experts. Ford looked at ways of increasing throughput and reducing movement and time wastage of workers. He took the parts to them and by repeating operations increased familiarity and speed of

INTRODUCTION

operations. With the introduction of a continuous flow assembly line Ford dominated the automotive industry. Because he only made the one model of car, his customer base was limited and the Europeans and Japanese fought back with the ability to supply what the customer wanted; more variety and choice.

After the Second World War, Taiichi Ohno and Eiji Toyoda devised the Toyota Production System, known as Just In Time or Lean Manufacture (Jones et al 1991). By making smaller batches of parts, Toyota found that they could do quicker part changeovers. With the reduction in die changeover times from a whole day to minutes a wide range of vehicles and variants was possible. It also meant that fewer parts needed to be stored and mistakes could be picked up before affecting hundreds or thousands of vehicles. In Europe dedicated machines, which ran the same part for years were commonplace, making it an expensive and lengthy process to change parts.

The Japanese workers expected jobs for life from Toyota and so to get the best out of them, Toyota made sure that all workers were multi-skilled and continually enhanced their skills. Improvements and suggestions came from the shop floor up. Every worker on the line still has the ability to stop it when they come across a problem that they cannot fix. In the beginning this meant that the line was always stopping, but as people learnt how to solve and eliminate the causes of the problems, the results were less rework and a better quality of vehicle being produced.

By consulting with suppliers and installing a Just In Time logistics system, Toyota found that they got the benefits of further reduced stock holding. Encouraging non-competing suppliers to discuss issues amongst themselves also improved technology offered to them. Another important breakthrough was building two or three vehicles at the same plant, improving the flexibility of vehicle mix and volumes further and decreasing idle time on machines.

Lean manufacture means drastically reducing the time and effort needed to change product or design. To work it needs to be applied from design, through production

to service. It means that time to market for a product is reduced as well as the inventory benefits already mentioned.

The press shop and company as a whole, employs most if not all of these ideas and now builds to customer specification with orders coming from the dealerships and the car being off the end of line within 6 days. Whole vehicle product changeovers can be done in a day. An example of this is the change from the old style model to a new style. All of this contributes to making it the most competitive car plant in Europe. Figure 3-2 shows this flow and where simulation would fit into it and the sectors that it would provide feedback to.

It is expected that simulation will help in this research by further improving the flexibility of production by finding and getting rid of bottlenecks and investigating capacity plans and schedules.

1.6 The Industrial Need

It is hypothesised that Discrete Event Simulation can drastically reduce the time it takes to analyse schedules with volume and mix changes, without negatively affecting the accuracy of the results. According to literature (Perera 2001), DES is very flexible, and therefore in this research, should be used as the basis of decision making for other projects around the shop such as capacity plans and model introduction and phase-outs. There are currently other projects going on in the Press Shop that would benefit from the use of simulation. For example, the introduction of a new die on one of the blanking lines has allowed for much greater flexibility on the lines. Simulation could be used to show the best line balancing for the lines or even as a tool to show if enough time was available to take lines out of production to run trials. Using DES often removes the need to use estimates and judgements when making important decisions.

1.6.1 Automotive Sector Facts and Figures

The automotive industry is of great importance to the UK economy. It is a major employer with 827, 000 jobs dependant on it. These jobs range from the actual manufacture of vehicles and parts (237,000) to sales, servicing and repair (555,000). The total sector turnover was £45 bn in 2000, with a 9.6% contribution to the total UK manufacturing turnover. The value of exports is around £20 bn, (around 80% of output) which counts as 10.5 % of total UK exports. There are more than 40 producers of cars, vans and trucks in the UK and around 7000 automotive suppliers. Having all of these manufacturers means that there is a lot of competition for the difficult European market. To compete, requires that production costs are low and efficiency is high. Britain has the two most productive car plants in Europe; Nissan in Sunderland and Toyota in Burnaston. In 2000, Nissan produced almost 328,000 cars using a practice of Kaizen, continuous improvement and the Japanese method of lean manufacturing and Just in Time production. Despite this it is still cheaper and easier to produce cars on the continent. Europe has a lower cost base and easier logistics for component procurement in the bigger European market.

Other tactics used to stay on top of the market are falling prices, low borrowing costs and revamped models. Time to market is crucial and new models and current model facelifts can make or break a company.

1.6.2 Mergers and over capacity

Figures published in October 2002 state that the British car industry is booming with car production up by 13% on 2001. (Figures are from the SMMT (Society of Motor Manufacturers and Traders) website, 2003.) After Germany, Britain has Europe's second largest car market. Estimated sales figures for 2002 are 2.5 million. In 2000 however a different view was held by many. At the time when plants such as Rover and Ford were closing, it was thought that Europe's car market was suffering from over capacity. It is estimated that Europe can produce six million cars more than it can sell (21million). Since then, alliances have been

formed, like the one between Renault and Nissan. This is in an effort to reduce costs by using common vehicle platforms, meaning the use of identical and similar parts and sharing costs such as logistics. Other such ventures include Ford buying Volvo, Daimler merging with Chrysler and the integration of Mitsubishi into the group.

1.6.3 Key factors to remain competitive in the automotive industry

To remain competitive, the following points should be considered;

- Short lead times
- A multi-skilled, flexible workforce
- Variety in design with add-ons to let customers personalise their purchase
- Flexibility of the plant

1.6.4 Facility Layout Constraints

In this research there is not any scope to move facilities because of their size and the resulting costs, it is however a factor that should be considered when looking at improving factory layout and improving efficiency in the factory.

Brown factory sites such as NMUK are where the plant is already in place when the research and planning takes place. Constraints such as fixed facilities are already present. There are limitations on floor space and transport systems and links, machinery upgrades, installations and modifications need to be carefully planned so as not to interfere with production, which incurs a cost penalty of several thousands of pounds per minute.

A green field site has none of these constraints and allows the designer free reign. This is where simulation can be used to optimise layouts and have most effect. See Figure 1-2 for where constraints are set in this thesis. Of the literature available very few researchers make the distinction between brown and green field

INTRODUCTION

sites when discussing modelling. Hence this research attempts to identify the constraints that a brown field site imposes on the modeller.

This chapter has described the outline of this research and has provided evidence for the need for DES using the principles of DET in a high volume press shop. The objectives have been stated and the methods of how these will be achieved have been discussed. The following chapters will put these methods into practice and show the findings of the research.

2 Literature Review

This Literature Review discusses the importance that the design techniques used for both products and processes have on the key competitive factors in the automotive industry. These are; short lead times, flexibility of a workforce and variety in design as first highlighted in section 1.6.3. The DET framework can be an invaluable tool for providing a system of feedback and maximising the use of data and information. Techniques which can be part of the DET framework, such as Life Cycle management, Design for Manufacture and Design for X, Concurrent Design, Product Data Management and Knowledge Management are examined. Their benefits and applications are discussed. A computer-based tool, which can be used to support all of these techniques, is discrete event simulation. DET can bring all of these aspects of design together and using DES provides a framework for increased interoperability of systems.

In the second part of the Literature Review, the development and use of simulation is researched, covering the key competitive factor of 'flexibility of the plant'. The other three factors are covered in both this and the design sections of the Literature Review. The many definitions of simulation are evaluated and the various modelling approaches are discussed. Elements of the approaches such as validation and verification are studied and the barriers to simulation in companies are considered from the point of view of simulation surveys and practical experiences.

2.1 Integration of DES with Design For X (DRX), Life Cycle Analysis (LCA) and other product design techniques

2.1.1 Digital Enterprise Technology

Brown (2000) says that the goal of Digital Manufacture is to provide the manufacturing community with solutions to create, validate, monitor and control

agile, distributed manufacture production systems geared towards build to order and lean production.

The Digital Enterprise Technology (DET) framework (Maropoulos 2002) in Figure 2-1 and 6.5 APPENDIX C provides a link between the digital and physical domains using simulation, factory and product design and feedback loops. DET is the "collection of systems and methods for the digital modelling of the global product development and realisation process, in the context of lifecycle management" (Maropoulos 2002). The main benefits that DET brings are; risk minimisation of a new product, digital manufacture and assembly of products, reduction of lead-time to market and most importantly a system of feedback to all those involved in the design process. DET involves looking at "Distributed and Collaborative Design", "Process Modelling and Process Planning", "Advanced Factory Equipment and Layout Design and Modelling", "Physical to Digital Environment Integrators" and "Enterprise Integration Technologies". One of the most important technologies in recent years is the internet and it is a key technology to facilitate DET. Feedback between all of these aspects allows users from different departments and functions and even countries to track and monitor the whole process. Simulation plays a key role in the integration of the digital domain and the physical environment. Levels one to three are entirely digital and consequently include deviations from reality. One major advantage of DES is the risk mitigation by the deployment of "time" within the 3D digital environment. Time, of course, connects the model with the real world and allows realistic decisions to be made concerning capacity, line balancing and lead times and comparing predicted data with actual results to 'calibrate' the model. As can be seen from Figure 2-1, DES is vital in providing feedback via simulation results to the three cornerstones that precede it and for the transfer between the digital and physical domains.

Many systems use web capabilities to link supply chains together. It makes sure that everyone has the right information at the right time. Users have confidence that they are using the most up to date data. To be effective the digital web

database needs to interface with multiple CAD systems, PDM and be easily interfaced with (Cheung 2002).

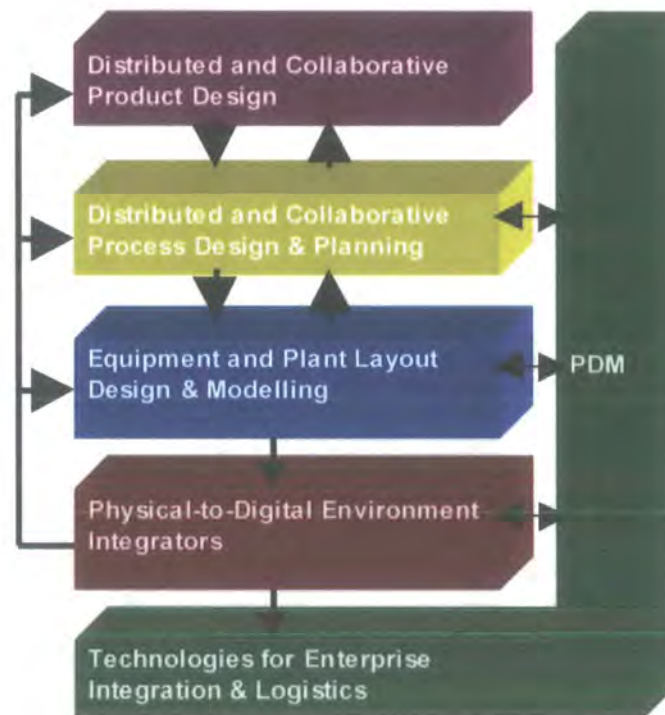

Figure 2-1 Digital Enterprise Technology Framework

2.1.2 The Early Design Stages

The design stage in a product or process life cycle is the time when the most significant cost and time savings can be made. It has been proven that the further downstream the life cycle modifications are made, the more difficult and expensive they are to make. Although continuous improvements (CI) make significant reductions in the production stage, these costs could have been avoided completely by thinking about life cycle implications early on. CI is also very restricted by the fundamental design of the product itself. Major changes to tooling and processes are almost impossible in the production stage. All that needs to be changed at the design stage however are the paper and electronic documents (Mirtinnen and Nemhard , 1997). More significantly for new process design but also

LITERATURE REVIEW

for product design, DET facilitates the feedback loop between the design planning and the equipment and plant layout via Product Data Management. The effect this has depends on whether the process site is green field or brown field.

All too frequently there is a desire to jump into prototype manufacture in order to reduce lead times. There is the worry that unless this stage is reached very early on, that the market share and introduction window will be lost. This is only really true for high-tech industries. What is very important at this stage is ensuring that all relevant parties have had input and that data where possible is reused from past projects to maximise knowledge transfer and data sharing via a framework such as DET. This can be using simulation or other presentation techniques.

Once a prototype is proven to meet the functionality requirements it becomes very hard to change people's mind set to new ideas and improvements. It is also very difficult to stop the momentum of the project. This means that it is very important to get everyone involved in the project to agree on the product specification very early on. A good product specification and functionality requirement reduces the number of queries later. This specification from the customer requirements can be created using Quality Function Deployment (QFD). The designer needs to be careful however not to over specify and complicate the initial design process. (Edwards 2000). These short design cycles make simulation important because a model is the quickest and most accurate way of evaluating a process when it is not possible to test it out on the production line. 'What If?' Scenarios can be carried out without the commitment of time or money.

2.1.3 Concurrent Design and Life Cycle Management

Concurrent design is when considerations of down stream implications are looked at early on in the project such as the life cycle processes of marketing, production, process planning, manufacture and disposal. Zhang and Xue (2002) define it as a sequence of life cycle processes done in parallel. This parallel method of working is further enhanced by the ability of all involved to have continuous access to what

LITERATURE REVIEW

is going on in different areas of the project. A DET framework is very effective here. All of these Life Cycle processes have costs associated with them, whether they are financial or environmental. An international product-modelling standard called STEP has been developed to integrate different product life cycle models using a universal computer language. Previously, it was necessary for all the databases to be in the same environment, but with technical advances in the Internet and distributed modelling and computing. STEP makes it possible to integrate models from different platforms; Windows, UNIX and Mac, and in different languages. (Zhang, Xue 2002)

70% of product costs are decided at the design stage and the further along the design and production process you progress, the greater the modification cost. Figure 2-2 by Wiendahl, Strzke (1998) shows how Japan differs from the West with modifications to design. In Japan, more changes are made early on before SOP where cost is small. In the West the attitude is more likely to be jump in and then see what does not work (Edwards 2000).

Simulation could be used to cut the number of modifications made to the product or process because scenarios can be tested quickly to find out the most efficient and discover what things might go wrong, for example finding bottlenecks or that the manufacturing sequence is too complicated. Holst (2001) says that Discrete Event Simulation (DES) is often used to troubleshoot specific problems such as bottlenecks, usually in the late stages of the manufacturing system lifecycle or as a stand alone tool, often lacking strategic focus. He also points out that the majority of manufacturers in Japan do not use DES at all because they do not have enough belief in what it can do for them in the present or the future.

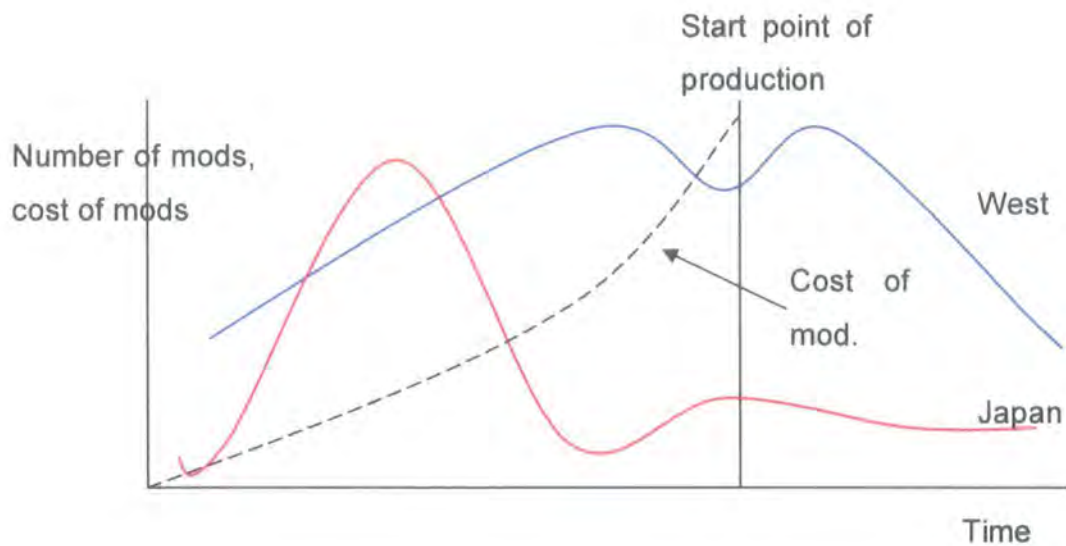

Figure 2-2 Comparison of modifications made in Japan and the West

To ensure that concurrent engineering and design techniques are put to best use, Williams (2001), believes that it is important to show the fundamental steps that should be followed so as to get the maximum benefit from them and to make them repeatable in future products. Formal tools and techniques that could be used are Design for Manufacture and Assembly (DFMA) and value analysis. DET can assist the adherence to techniques such as DFMA because it provides a framework that can cope with varying data requirements and systems throughout the project. If this framework is planned correctly, the duplication of redundant data is eliminated. This means that people from all aspects of the project can view data from a variety of medium at any time, safe in the knowledge that what they are looking at is the most up to date information.

DFMA involves deconstructing a large complex problem into smaller design tasks that can be distributed to teams and worked upon concurrently. DFMA looks at how a product will be made and the cost and ease of its manufacture. It looks at the ergonomics of manufacture and strives to make it as simple as possible for the operator. Items produced are often modular and are made in family sets using the same materials and tooling. The layout of the manufacturing process is set out to

LITERATURE REVIEW

create as little reaching and movement for the operator as possible. Components are easy to handle and integrate with each other simply without excess force. Boothroyd and Dewhurst state several advantages of DFMA such as, speed of investigation of materials and processes, shortened development time and increased consensus among the team and provision of unbiased costings leading to meaningful discussions in the supply chain. This reduction in development time may be because of the use of simulation. Types of 3 D simulation can be used to show how parts fit together and find the optimum assembly sequence. Other techniques may be Design for the environment, which is becoming increasingly important in today's conscious market. This is especially prevalent for the automotive industry. There is lots of research into alternative fuels and the reduction of emissions during a vehicles useful life. The actual manufacture and materials are also important, for example the paints used, how the raw materials have been extracted from source. As Life Cycle Management is a cradle to grave concept, the consequences of disposal are also important. Can the product be split into its component parts and re-used or recycled? If not, how long will the product take to biodegrade? What effect will this process have on the environment? Can the raw materials be sustained? Sustainability is the economic, social, environmental value criteria, which is determined by interest groups around the company. (Alting et al 1998) This could be shareholders, customers, suppliers, employees, the local community or political interest groups. It is impossible to suggest that a designer could come up with all the answers to the problems that may arise in and after production. This is why it is essential that a multi-disciplined team be involved throughout the design process, using tools such as simulation to shorten the lead times and reduce the number of modifications required and the number of mistakes being made.

The complete Life Cycle Approach (LCA) has four stages (Miettinen, Haemaelaeninen 1997).

1. Goal definition and scope – Planning stage
2. Inventory analysis – calculate material and energy balance of system
3. Impact assessment

4. Improvement assessment

With production increasing it is increasingly important to consider the whole life cycle of a product, rather than just its manufacture.

It has been found that LCA can simplify products and reduce costs. Simulation can be used through all of these stages. For a new product it is especially important in the planning stage to reduce lead times and eliminate potential bottlenecks. In inventory analysis, as used in this research, inventory levels can be examined at different times during the production process and schedules can be optimised or made more efficient. For impact assessment simulation is important to reveal the effects of volume or product mix changes on a production line. In improvement assessment simulation is used widely when a product or process is already in place. It is useful for improving facility efficiency and carrying out 'What If?' scenarios of product or process changes.

2.1.4 Design for X

Boothroyd and Dewhurst were the founders of the DFMA practice. Their aim was to systematically analyse product designs with the goal of reducing manufacture and assembly costs. Advantages of such a technique are;

- Reduced part count
- Shorter time to market
- Improved quality through assembly simplification
- Lower overheads

Van Vliet et al (2002) have the opinion which the author is in agreement with, that for DFX to be effective, it needs to be considered throughout the entire design process and have feedback loops to ensure continuous design evaluation and co-ordination. Despite its potential DFMA is not used much in industry since its heyday post World War 2. This is because in a time of scarcity of tools and materials, practices which reduced the number of components and tooling was essential. Today it is often only desired and not essential to do this.

According to Antony and Coronado (2002) the benefits of all of these Design for X approaches are;

1. Reduced time to market
2. Reduced Life Cycle Costs
3. Increased understanding of customer expectations and priorities
4. Less design changes or iterations
5. Less prototypes
6. Better quality and reliability
7. Better management of risk
8. Lower warranty costs
9. Bigger market share and business profitability

Some of these points are similar to the benefits expected from using modelling techniques, especially in the case of the press shop model, points 1, 4, 6 and 7. These demonstrate how the use of early analysis and using historical data for example can save time and effort as well as make cost savings without prototype manufacture. It could be said that simulation and DFMA both have the properties required to carry out this early analysis. The chart in Figure 2-3 below shows how much companies can expect to save in different areas of the product life cycle if they use DFMA and other DFX techniques.

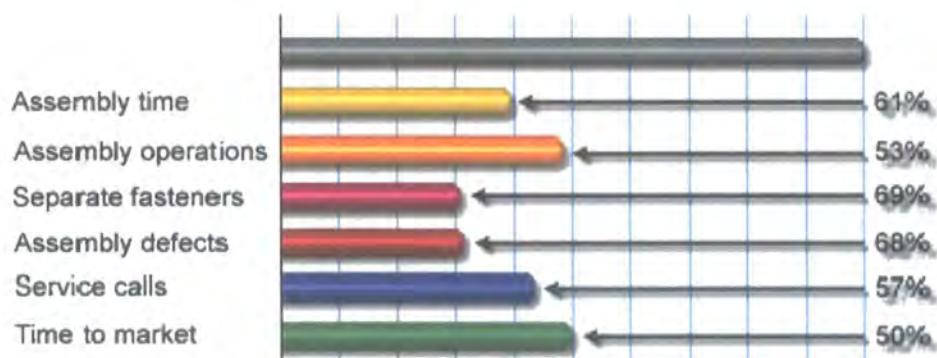

Figure 2-3 Percentage reduction because of DFX (reproduced from DFMA.com, 2002) Boothroyd and Dewhurst

As already mentioned, there are several different components of DFMA. They are

LITERATURE REVIEW

- DFA – Provides product simplification. It is the core software tool for Concurrent Engineering (CE).
- DFM – helps with the selection of materials and processes. Gives piece part and tooling cost estimates, which can then be fed back to DFA. Is more accurate than other approaches because it does not rely on historical data.
- DFS } (Design for Service and Environment) They are used to improve serviceability, maintainability and assess the environmental impact of the final design
- DFE }

DFS is becoming more and more important as consumers are demanding more from the products they buy. By considering service factors at the design stage, manufacturers and consumers can benefit from reduced warranty costs, improved customer satisfaction and more environmentally sensitive products due to their longer useful life. These techniques may incorporate simulation as a tool to increase their effectiveness.

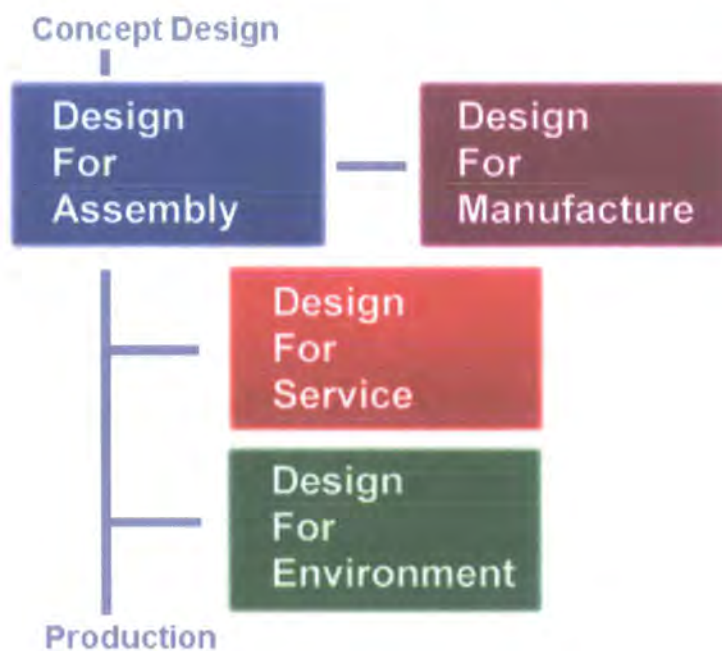

Figure 2-4 Flow through DFX, Boothroyd and Dewhurst (reproduced from DFMA.com, 2002)

2.1.5 Product Data Management

Product Data Management (PDM) is a computing system used to manage electronic data collected from different functions. It enables different communications media to share data in internal structures. For example, from CAD/CAM and CIM systems using different coding languages such as C++, Java and Visual Basic (Oh et al 2001). PDM is used to reduce time to market, create new markets and exploit data, information and knowledge assets. PDM has been around for about 30 years and is used to solve information bottlenecks and provide timely and relevant product data to any users within and beyond the organisation, by maintaining engineering Bill of Materials (BoM) and its configuration. It is also responsible for drawing and engineering change management functions and the management of CAD files. This is possible via the use of the World Wide Web, Intranets and computer networks. PDM is important for simulation because it provides a medium for carrying data to and from the model. It makes results of simulation easy for all users and those involved in the product or process to access at the same time. They are able to change inputs and disseminate the results individually or as a team (Chen, Simon 1999). PDM is also an integral part of DET.

Cheung et al (2002) agree that PDM and manufacturing models need a collaborative product development and manufacturing environment in order to improve decision support on product development processes. PDM is commonly used within large organisations such as the automotive and aerospace industries where there can be 20 000 to 50 000 users on the same system. By working from the same source of product information, lead times and data duplication and errors are reduced. Everyone is working from the same version of information at the same time. This means that parts are not being designed that will not fit together, manufacturing costs are reduced, purchasing are buying the right parts and production are making the right parts (Fan 2000). DET embraces this idea and by maximising the interoperability of systems through PDM makes simulation modelling and results easier to feedback and disseminate.

Security can be put into place to ensure that only people with the correct access rights can read, write or change files. Systems can also be set up to inform relevant users by e-mail of changes to drawings or specifications. This means that time waiting for agreement from the parties concerned is reduced. PDM is used to integrate CAD, CAM, simulation and CAE, which are developed independently into a common environment throughout the product life cycle. (Oh, Han and Suh 1998).

2.1.6 Knowledge Management

Knowledge Management Systems are required to capture design intent, rationale and historical knowledge to capture, organise and manipulate in order to help generate new design knowledge (Lang et al 2002). Knowledge Management tries to make more efficient and effective use of expert human resources wherever they are geographically or organisationally. History of design is very important because the majority of designs are built on existing designs and a knowledge base of existing designs shows what does and does not work. 'What If?' scenarios in simulation can be used to test these and possible design changes if further verification is required.

Distributed Knowledge based modelling is the development of multi agent systems to solve problems through collaboration among different types of knowledge in different agents (Zhang, Xue, 2002). Data is facts in their most basic form. For example this could be 25 or Newcastle. Information puts this data into context, such as £25 cost to buy a widget, place of conference is Newcastle. Knowledge is the merger of the data into a more personalised and contextual form. There is a switch going on from data and information management, which are of lean content to knowledge exploitation, which is rich content (Lovett et al 1999). This could be the integration of text, audio and video to capture and reuse knowledge. Simulation is a good way of visually displaying knowledge and convincing people that ideas will or will not work. Companies are focussing on knowledge to try and get the promised benefits of knowledge exploitation. Previously, e-mail was considered as

LITERATURE REVIEW

the main technology medium for this exploitation, but it did not deliver the amount of profit and customer satisfaction as promised (Breu et al 2000). The web and Intranet applications reach a larger number of people in a more interactive way. They can be used to carry out product surveys and gauge employee consensus about how the company is operating. This information gathered from the surveys can then be translated into knowledge and used to improve future products and company decisions. This information can be stored via PDM and using DET techniques it can be reused and analysed very efficiently. The author believes that simulation is vital for improving products and processes and can use the knowledge gathered to perform 'What if?' scenarios. The results can then be fed back via PDM and used to allay people's fears of a new process before it is introduced. The web increases the accessibility of tools and methodologies and provides a more consistent interface between the computer and users.

Another use of knowledge is Knowledge Based Engineering (KBE), which uses rules and formulas to automatically generate and modify CAD models. KBE is used for knowledge elicitation, formalisation and validation, interface and functionality design and user acceptance.

Collaboration between experts is essential and successful collaboration comes from the efficient sharing of knowledge, negotiation, co-ordination and management of activities (Lang et al 2002). Knowledge bases are considered crucially important in improving the capability of computer aided concurrent design systems. (Zhang, Xue 2002)

2.1.7 Analysis of findings

An analysis of this section of the literature review shows that design needs to have more emphasis than it is currently getting in terms of Life Cycle Analysis. It should not be the pattern that things can be fixed later and that it is more important to get to market first, than get to market with a quality product. Good design, can in fact, cut time to market and techniques such as PDM and distributed design, make it

LITERATURE REVIEW

easier for individuals across the organisation to work concurrently on designs via Intranet and computer networks. Tools such as simulation can be used in the design process for both product and process and can help reduce time to market further by allowing the user to carry out several 'What If?' scenarios without taking up time and expense on the production lines or for prototype testing. The benefits of simulation techniques need to be compared to the benefits brought about by tools such as DFMA to see which are the most effective.

Frameworks such as the DET example can be used to share the design information effectively and provide a system that alerts users to new information, thus reducing the time to review and ok new ideas. Modelling and Simulation are good preparation tools for design and process engineering decisions in real world systems, which when used properly as discussed in 2.2 have numerous financial and time saving benefits as an indispensable problem solving methodology.

Because the press shop is on the same site as the rest of the factory it was purpose built to supply the body shop and provide the shortest route of flow through the manufacturing process. In terms of process design, the shop is set out in such a way that agrees with the principles of DFMA by Boothroyd and Dewhurst. This flow can be seen in Figure 3-2. Because it is a brown field site, there is no opportunity to look at reorganising the process flow in this research, but it should be considered when looking at other applications of simulation in other areas of the business such as installing a new facility such as a new press or laser.

2.2 Simulation

2.2.1 What is Simulation?

There are many different definitions of what simulation is and what it is used for. It has been used since the early 1960's to assist in the decision-making processes within industry. The following are some examples.

According to the Oxford English Dictionary, simulation is "The technique of imitating behaviour of some situation or system by means of an analogous model, situation or apparatus, either to gain information more conveniently or to train personnel".

There are several more academic descriptions of simulation and its uses, some more accepted than others.

- Simulation is a highly effective analytical tool for assessing the quality of design of a production system relative to its ability to meet production goals of quantity and quality within constraints of operational complexity and cost (Seila 1995). Basically, this means using simulation to assess the capacity of a production system, whilst considering cost and possibly model mix.

- Evans and Olsen (1998) say that simulation is used to predict, explain, train and identify optimal solutions. Bowden and Hall (1998) agree by stating that Simulation is used to determine the state of certain controllable inputs to cause system outputs to be at their most favourable or optimal condition. This is a common use for simulation and many software packages now include optimiser functions. Another way of reaching near optimal solutions is by carrying out several production runs and slightly changing variables. Pidd (1998) agrees with this and has written that simulation is used to investigate possible improvements in a real system and discover the effect of different policies on that system.

LITERATURE REVIEW

- Smith and Peters (1996) describe a use of simulation in the design stages. This is the optimum place to start using simulation but is often neglected. They claim that simulation tools are primarily used to evaluate candidate designs to aid in the decision of design selection. This contradicts Holst (2001) who believes that simulation is more often used for troubleshooting bottlenecks in existing systems too late in the manufacturing lifecycle. This means it can only have a limited effect.
- A valid point is made by Law (2001) who states that simulation models are the surrogates for experimentation with the actual system, which can usually be disruptive, not cost effective, or simply impossible. The author believes that this is the reason that a lot of companies choose to use simulation. Production lines can continue to run and there is not the cost of downtime or making prototypes to test theories. Banks and Carson (1984) agree and say that simulation is the imitation of a real world process or system that removes the need to test experiments on line. Centeno and Carillo (2001) make a similar point that simulation modelling enables the mimicking of reality.
- A successful simulation project delivers useful information at the appropriate time to support a meaningful decision (Sadowski and Grabau 2000). Timing is very important in a simulation project. If the information is late then it may become obsolete. The delivery of results may be linked to the complexity of the model. The more complex the model, the longer it will take to verify and validate it. With complex models there is often a lot of information to understand. According to Knoll and Heim (2000) simulation is good for this purpose and for taking the guesswork out of project planning.
- According to Ingalls (2001) simulation is the process of designing a model of a real system and conducting experiments for the purpose either of understanding behaviour of a system or of evaluating various strategies for

LITERATURE REVIEW

the operation of the system. This covers all of the points that the other authors have made and is the idea that can be identified with the most.

Law (2001) believes that there are seven processes in the modelling project as shown in Figure 2-5

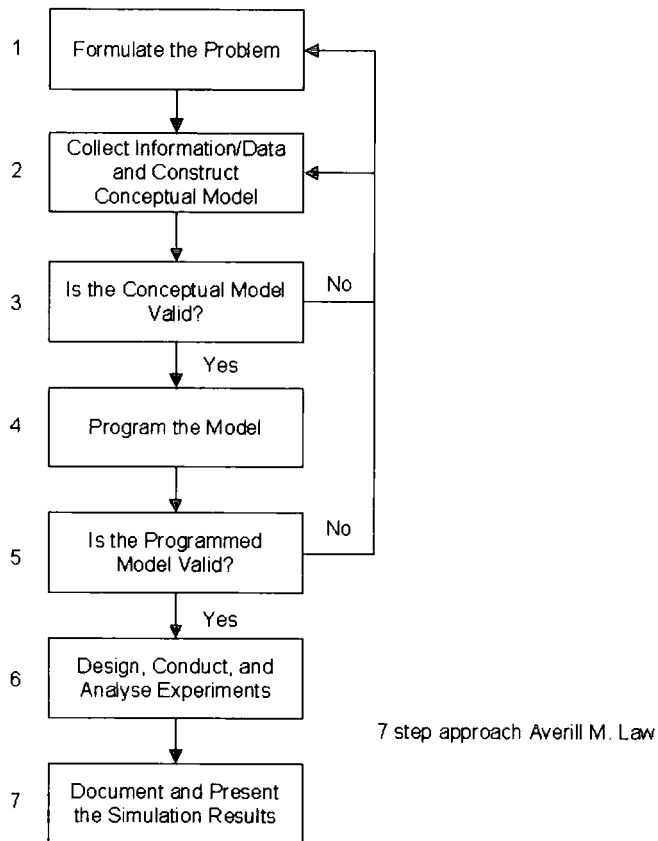

Figure 2-5 Law's approach to Modelling (Law 2001)

2.2.2 Elements of a simulation study

An idea that is supported by many including Banks (2000) is that a simulation study involves 12 points

1. Problem Formulation
2. Setting of objectives and overall project plan

3. Model conceptualisation
4. Data Collection
5. Model Translation
6. Model Verification
7. Model Validation
8. Experimental Design
9. Production Runs and Analysis
10. More runs
11. Documentation and Reporting
12. Implementation

Point 4 - data collection is further explained by Leemis (2000) as either the classical or the exploratory approaches;

The classical approach is when a designed experiment is conducted.

The exploratory approach is when questions are addressed by means of existing data that the modeller had no hand in collecting.

He states that the classical approach of data collection is better in terms of control and the exploratory approach is better in terms of cost.

Comparing the modelling flows of Law (2001) and Bank's (2000). A combination of both is the preferred ideal and, depending on the situation, these models should only be used as guidelines. Twelve points are often too many for a simple simulation and many points can be combined. It is up to the user to decide which points are essential and which can be delayed or ignored. For example experimental design may be brought under the heading of model validation or it may be ignored altogether, with the user going directly to runs and analysis in order to get value from the model as quickly as possible. Irrespective of the methods chosen, it is essential that a methodical approach and framework are used when formulating the model in order that it is fully documented and interpretable by others.

Centeno and Carrillo (2001) believe in the following. Figure 2-6 Centeno and Carrillo's Modelling Technique

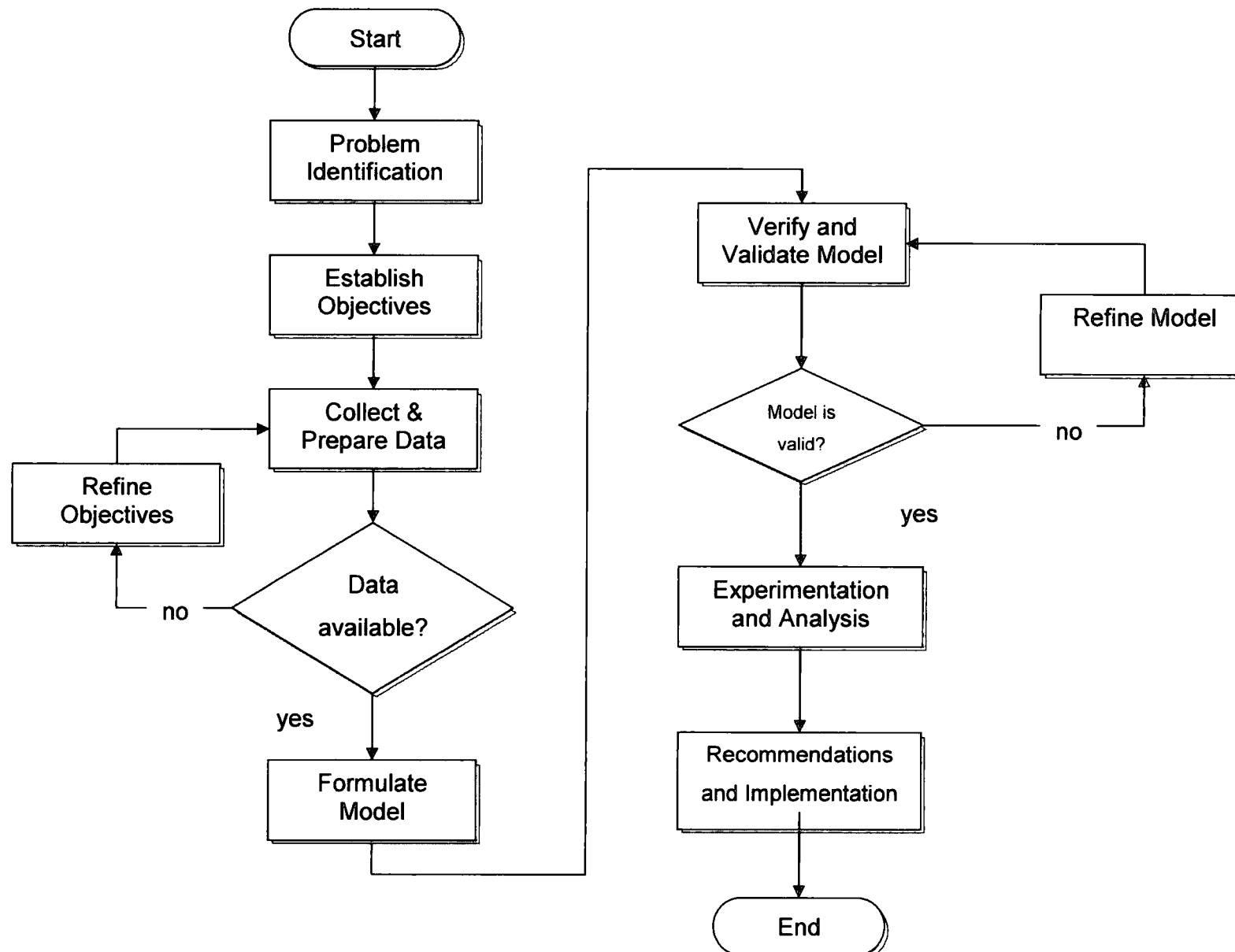

2.2.3 Usage of Simulation

Centeno and Carrillo (2001) believe that success is more probable if a model has clear objectives, it is planned carefully, a realistic time line is developed and the project is continuously reviewed and reassessed as it evolves. Pidd (1996) states that key success factors in simulation are programming and experimentation phases.

Law and McComas (1998) say that simulation can be used to investigate a wide range of operational areas which are relevant to the aims and objectives of this research.

The model proposed for the press shop will encompass all of the factors shown in Table 2-1 bar new equipment and quality control. New equipment would be a factor for a green field site or even a brown field site with new product/process requirements. To do this effectively a framework such as DET is required to ensure that all inputs are as accurate and up to date as possible and that all those concerned with the results are in the feedback loop.

The need for equipment and personnel	Operational Areas		
	Performance	Operational Procedures	Performance Measures
Shifts	Throughput	Production Scheduling	Throughput
New equipment	Time in system	Inventory	Utilisation of equipment and people
Consequences of change in product mix and volume	Bottlenecks	Reliability	
Buffers – size and location		Quality Control	
Logistics, pallets and fixtures			
Number, type and layout of machines			

Table 2-1 Areas for investigation with simulation

2.2.4 Simulation Surveys

Many surveys have been carried out into what types of simulation companies and universities like to use and into what features are the most important when selecting the most appropriate software package for simulations. Nikoukaran and Paul (1999) summarise that the most important feature is a consistent, user-friendly interface. Other factors are an interactive debugger, the software

LITERATURE REVIEW

package's storage capabilities, interaction via a mouse and the ability to graphically display input, output and run-time statistics. Hlupic (1999), who performed a survey across a wide range of companies and universities, reported that the most widely used software packages are Simul8 and Witness and found that most people tend to use only one or two software packages. The survey was not representative of real industrial needs because it was quite heavily biased towards universities. This is because the response rate to the surveys was quite poor from the companies questioned. This is obvious in some of the results because most universities use simulation software packages for teaching and research (In this case, two separate surveys would have been better, one directed towards use in companies and consultancies and the other for education and research. Bearing this in mind, the survey found that ease of learning and use was the most important criteria in selection of a simulation software package.

2.2.5 Introducing Simulation into Factories

Simulation is often championed by an individual in the company. This is a view shared by many including Centeno and Carrillo (2001). If it is one person promoting the use of simulation in the company it may be difficult to get the support of others. Common challenges are;

- Acceptance of Staff
- Availability of staff
- Existence of useful data
- Management expectations

By getting people involved from the start in areas such as system requirements and data collection using techniques such as PDM in the DET framework, acceptance is more likely as is the implementation of the results.

Perera (2001), has also found this to be the case in the UK. He also found that in the UK simulation is often only used for specific applications with a low profile

LITERATURE REVIEW

instead of continuously. This results in a general lack of skill, meaning that consultancy is often relied upon. The following diagram Figure 2-7 shows the most common barriers to simulation

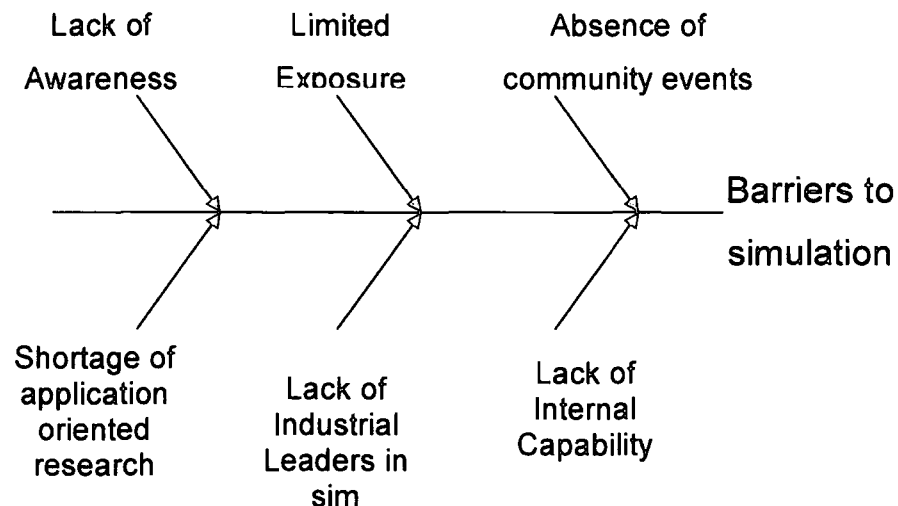

Figure 2-7 Perera's (2002) fishbone diagram

Unless these challenges are overcome, it may be very difficult to obtain funding and collect the data needed for the simulation. It may be beneficial to let others know the benefits of simulation for the company. These are described by Centeno and Carrillo as;

- Simulation is cheaper and more flexible than experimenting on the real thing
- Models built can be used repeatedly
- Simulations are usually easier to apply and understand than analytical methods
- Simulations do not require simplification like analytical (spreadsheet) methods
- Simulations can provide estimates of the time in the system and worker and machine utilisation, the number in queues and the time in the queue.

It also needs to be remembered however that simulation does have its limitations as well as capabilities.

- The optimisation of a system is only an estimation and is only the results of the scenarios tested.

LITERATURE REVIEW

- The quality of the information output is only as good as the information input.
- Simulation does not solve problems, just provides information to assist the user.

Perera (2001) suggests solutions to the lack of use and understanding of simulation in the UK. These include being taught simulation earlier at university. He also talks about the involvement and promotion of simulation by professional institutes, have more commercial events such as the Winter Simulation Conference in the USA. At the moment the events that the UK has are attracting more attention from universities and researchers, but companies need to get more involved if simulation is to become more widely accepted. Holst (2001) has done research showing that the countries particularly slow in accepting and using DES are Sweden and Japan. Often the tool is under utilised he agrees and is often used on a one off basis instead of on going projects and long term planning.

In general, making simulation more accessible with customised platforms and standard templates is seen by many people, including the author, as a way of making taking on simulation tasks less daunting. There is also the question of cost as many SMEs couldn't afford personalised software packages.

2.2.6 Simulation compared to manual or spreadsheet methods

Seila (2001) promotes the use of spreadsheets in place of actual simulation software packages as a user friendly platform that most people have access to with the first dating back to 1961. (The most well known software package being Microsoft Excel). Spreadsheets can represent mathematical and logical relationships between variables. Spreadsheets can generate random numbers and variables and have a tabular structure, which allows the developer to organise computations and results in a natural and intuitive manner. There are however limitations;

1. Only simple data structures are available
2. Complex algorithms are difficult to implement

3. Spreadsheets are slower than simulation software packages
4. Data storage is limited

Spreadsheets are good when ballpark figures are sufficient, but for complex structures with accurate inputs requiring accurate outputs, simulation software packages are a better solution.

2.2.7 Alternatives to Simulation

Alternative methods to simulation are String diagrams and cell clustering. String diagrams present a graphical display of a proposed layout with the material transport links superimposed on it. Cell clustering breaks components down into part families and machines into groups by using a matrix of which parts can run where. (Alexander and Chandrasekharan 1991) This is good for when there are a high volume of parts. These methods are used to minimise material flows and so eliminate the waste of movement.

2.2.8 Types and uses of simulation software

The two types of software are Languages and Simulators. Languages use straight forward programming such as C or Java to mimic reality whereas simulation is mostly done using a graphical user interface, often with only a small amount of programming knowledge require. Surveys by Nikoukaran (1999) and Paul Hlupic (1999) have shown that most people use a combination of both or just simulators. Simulators are more flexible, user-friendly and increasingly powerful but languages may be preferred for more mathematical and statistical problems where it is not necessary to see how parts in the model develop or move. However, it is up to the user to make sure that the software is appropriate for the application area.

Languages are either GPSS--General Purpose Simulation Languages or GPP--General Purpose Programming Languages. The user needs to make sure that the software is appropriate for the application area. The choice of software is primarily a matter of taste or of convenience.

2.2.9 Discrete Event Simulators

In Discrete Event Simulation (DES) the model progresses each time something happens in it (an event). The model is said to be dynamic and the events happen at defined times and logic in the software allows the model to react to the sequence of events. DES can be utilised for analysing product mix for production planning and scheduling (Al-Aomar 2000). Schriber and Brunner (2000) describe DES thus; the state of the model only changing at discrete but a possibly random set of simulated time points. Discrete Event Simulation has been used in the manufacturing industry since the 1960's (Holst 2001) and has become an extremely powerful tool.

Figure 2-7 by Schriber and Brunner (2000) shows the differences between the process design and marketing driving the use of DES. In Figure 2-8 the first diagram of an already established process is reviewed by DES and improvements made to result in the actual process. In the second diagram the market displays the need for a new process/product and DES is used right from the start to come up with the best process. The second method is better where there is no current process and fewer constraints. The first is used to see if there are better ways of doing a process and how many improvements can be made.

Smith and Peters (1996) propose the use of discrete event simulation for the production of short-term schedules. Traditionally simulation is used for long-term analyses. With computers becoming faster and more powerful, more complex simulations with several replications are possible. With simulations becoming more interactive, it is possible to evaluate and develop and adjust schedules quickly. There are software packages which concentrate on short term schedules, but Smith and Peters (1996) point out that whatever software package is used it is vital that all data is known and that you cannot model with uncertainty.

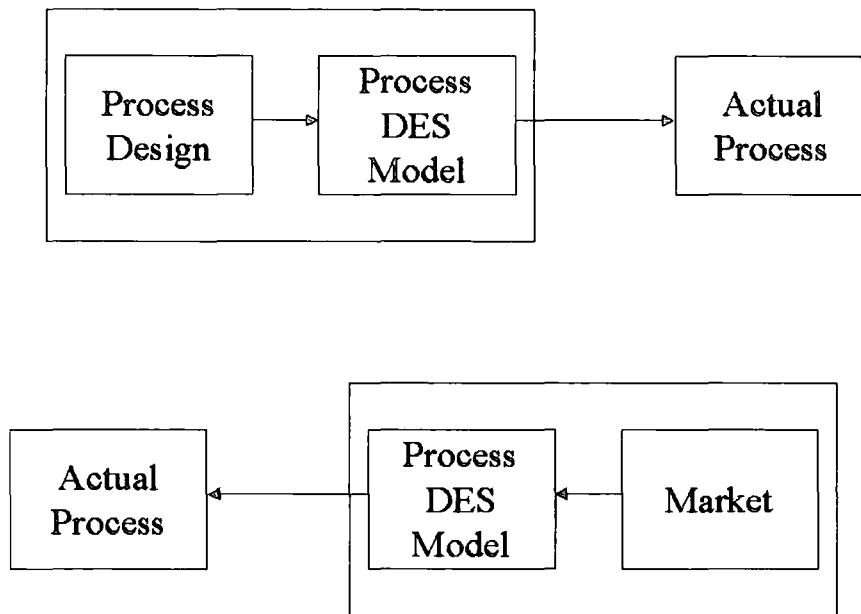

Figure 2-8 Process Models (Smith and Peters, 1996)

2.2.10 DES Terminology

An event is a happening that changes the state of a model/system or as Ingalls (2001) puts it, an event is the conditions that occur at a point in time which cause a change in the state of the system. He also describes the other parts of a simulation model; Queues are places in the simulation where entities wait and an entity is a unit of traffic that responds to an event.

A resource is a system element that provides a service to the model users, which are usually entities. Resources are usually capacity limited. A control element supports other types of delay or logical alternatives based on a systems state – switches, counters etc. An operation is a step carried out on or by an entity while it moves through a system.

Banks (2000) and Carson add that an attribute is a property of an entity and an activity is a time period of specified length. An event is an instantaneous occurrence that may change the state of the system. A system is a group of objects joined together in some regular interaction or interdependence toward accomplishment of some purpose.

2.2.11 Simulation Optimisation

Simulation Optimisation provides a structured approach to determine optimal input parameter values. (Swisher et al, 2000). Optimisation is important because trying different things and running the model is a very inefficient way of getting results and attempting to learn about the model (Kelton, 2000). Simulation optimisation is the practice of linking the optimal method with the simulation model in order to determine the appropriate settings of certain input parameters to maximise performance of simulated systems. Simulation optimisation is the use of search methods to find input parameter settings that improve selected output measures of a simulated system (Boesal et al 2001) and (Bowden and Hall, 1998). Optimisation of performance measures are based on outputs from stochastic (mainly DES) simulations (Fu 2001)

It is now commonplace to have optimisers that are already integrated into the software package. The user can then choose the scale of the optimisation search most suitable to the required accuracy of the model.

Common domains to look at with optimisation models are

- Methods
- Classification
- Strategy and Tactics
- Intelligence
- Interfaces
- Problem formulation

Fu (2001) states that there are essential pieces of information required for optimisation;

- Input and output variables
- An objective function
- The constraints

Optimisation is difficult if there are a large number of variable types. The optimum performance can never be evaluated exactly, just a close approximation achieved.

Procedures that can be used for optimisation include,

- Statistical procedures, e.g. ranking and selection procedures
- Metaheuristics, e.g., Genetic algorithms
- Stochastic optimisation, e.g., Random search or stochastic optimisation
- Others, e.g., Ordinal optimisation, simple path optimisation

2.2.12 Animation

Animation is the bridge for non-experienced users to more complex models and helps people to visualise models making them more likely to trust outputs if they can see what is happening. (Knoll and Heim 2000). These visual systems have only been available since the late 1970's and before this, models were simply black boxes, with data going in and results coming out (Robinson, 1994). This made it difficult for users to have confidence in the model and to give the results any credibility. This leads onto Smith and Peters (1996) believing that graphics are important in the development, validation, verification and marketing of results. A graphical user interface makes simulations easier to use.

The downside however is the amount of memory that animation takes up and the time it takes to draw and run. Complex animation should only be used where absolutely necessary to keep model size and development times down.

2.2.13 Model Complexity

Complexity can be looked upon in a variety of ways such as looking at the number of entities the model contains (Simon, 1964), the level of detail (Webster et al 1984) or the difficulty of understanding the system being modelled (Golay et al 1989). The author believes it is down to the experience of the modeller of the system being modelled as to which definition is most appropriate. For a user that is confident in the understanding of a system, their only problem will be deciding what data is essential for the model and what, does not add anything to the accuracy so could be left out. The inexperienced user is faced with the daunting task of breaking down the processes so as to understand what's important and what is not to the final desired result.

A complex model is one, which has several parts or elements in the system. Simple models are easier to implement and validate and change in a shorter time scale. Pidd (1996) declares that "complicated models have no right of acceptance", which is collaborated by Salt's idea (1993) that "simplification is the essence of simulation" These ideas promote simplifying a model as far as possible without losing the accuracy deemed necessary by the user. This saves time and computational memory, which could be argued is not as important today as it was historically due to improved computer performance. (Chwif et al 2000). If a model is simple and has only taken a short time to produce, the user is more likely to be able to discard it and start again if the model fails or parameters change, rather than struggle to adapt it because it has taken so much effort to build. (Salt 1993). Care should be taken however not to over simplify the model, or too much accuracy is lost and the results become worthless.

LITERATURE REVIEW

Complex models have the advantage of increasing the 'Show-off' factor, which could be important when trying to sell a process or new product to managers or customers. This is related to human nature that the product/process animation looks good on the screen, so they buy into it. A complex model will most probably also represent reality better than a simpler one, but as Salt (1993) points out that a complex and fully detailed model can be completely imprecise. Complex models are also more difficult to validate and so put confidence in.

To avoid the pitfalls of either putting in too much detail or over simplifying the model Pidd (1996) suggests starting small and adding later when there is the evidence that the data is required to improve the accuracy of the model.

2.2.14 Schedules

A schedule is the assignment of scarce resources to competing activities over a given time horizon to obtain the best system performance considering due date, lot size, timing and quantity of order release (Kempf et al, 2000). Scheduling is the time-sequenced allocation of resources (Czarnecki et al, 1997). It has been proven that spreadsheets lack flexibility to rapidly modify schedules based on changes in customer demand.

2.2.15 Modelling Approaches

Mehta and Rowles (1999) suggest that there are two types of modelling approaches;

- Internal Consulting
- Distributed Approach

Internal consulting uses a centralised department of modellers that tackles all of the simulation needs of the company by acting as consultants to the end users of the models. The consultants become tool experts and are more likely to follow standard modelling procedures. Knowing all the shortcuts reduces model build time

LITERATURE REVIEW

enormously and being an outsider means that a seemingly complex system can become much simpler by discounting superfluous information. Disadvantages however are that the consultant needs educating about the real system for every model undertaken.

In the distributed approach many modellers build and analyse simulation models. These are the same people that will be the end users and analyse the results. This creates an approach using excellent local process knowledge and creates a flexible and multi-disciplined workforce. Unfortunately models are likely to take longer to create by the infrequent modeller and models could be far too complex.

2.2.16 Product Mix

DES makes it possible to analyse various product mixes quickly and easily. Simply by changing the inputs, the model can show the consequences of changes in product mix. According to Al-Aomar (2000), this makes both the model and the production system very flexible. Flexibility is the key to success and survival in fast moving business, which demands continual improvement in delivery times, operational costs, capacities, material utilisation and information flow.

Product mix can be used to get the maximum flexibility and capacity out of the plant.

2.2.17 Verification and Validation of simulations

This is a very important part of the simulation process. There is no point in producing a model if the user is not confident in the outputs. Sargent (2000) describes verification as ensuring that a computer program of a computerised model and its implementation are correct and The Defense Modelling and Simulation Office (1996) describe it as the process of determining that the model implementation accurately represents the developers' conceptual description and specifications. Meanwhile a more simplistic explanation by Centeno and Carrillo (2001) is that verification is checking that the model has been built as intended. Hu

LITERATURE REVIEW

et al (2001) agree with this. Centeno and Carrillo (2001) also state validation as the process of ensuring that the model truly represents the real world.

Schlesinger et al (1979) state validation as the substantiation that the model, within its domain of applicability, possesses a satisfactory range of accuracy consistent with the intended application of the model. Law (2001) adds that validation is the process of determining whether a simulation model is accurate replication of a system for particular objectives of study. Validation is an expensive and time consuming exercise so it is important that a model is kept as simple as possible to make the process a lot easier. Hu et al (2001) agree with this statement by saying that validation is the process of determining the balance of the framework of the model from the perspective of its intended uses of the model.

Sargent (2000) and Centeno and Carrillo (2001) are of the opinion and the author agrees that users and potential users need confidence in the models they produce and use. The amount of accuracy required in the model should be specified and agreed to by all parties involved at the start of a project.

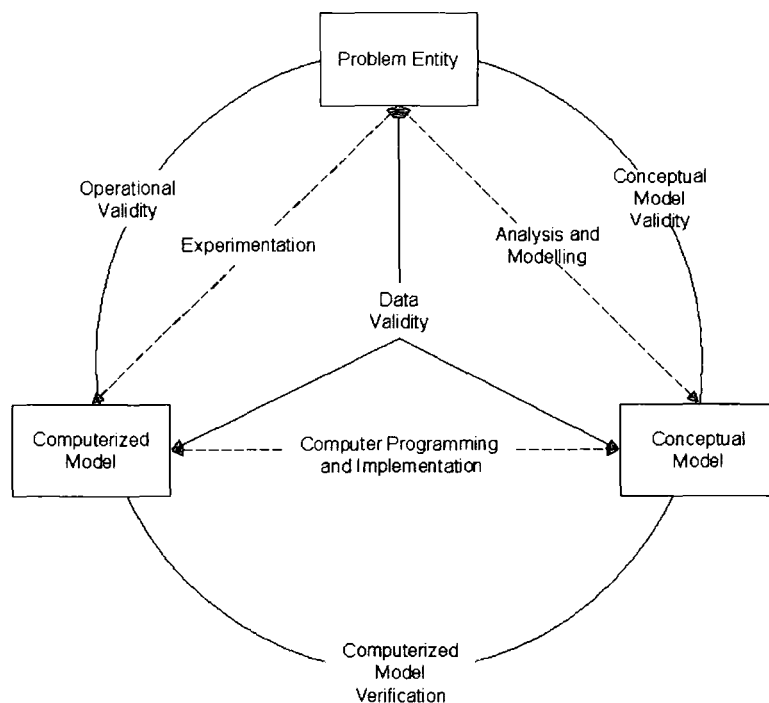

Figure 2-9 Model Validity

Figure 2-9 reproduced from Hu (2001) shows how important and necessary it is to validate and verify a model at all stages, from concept and programming to experimentation.

Validation techniques include the use of animation, comparison to other models, historical data validation, traces and extreme condition tests and in some cases it may be considered necessary to test the model itself by running the program under different conditions and looking at structure properties and performing program walk throughs.

It needs to be remembered that all projects are different and so the techniques used to verify and validate them are as unique as the project. Williams and Gevaert (1997) say that all the assumptions in a model should be listed before beginning the model so that the modeller need only validate the dynamic variables in the model and hence save time in the process. Additionally it is important to ensure that all involved agree on the constraints and accuracy that the model will use.

Verification and validation are important in increasing the user's confidence in the model. Figure 2-10 used by many authors such as Hu et al (2001) and Sargent (2000), shows the relationship between value to the user, cost and confidence in the model. User value increases with model confidence.

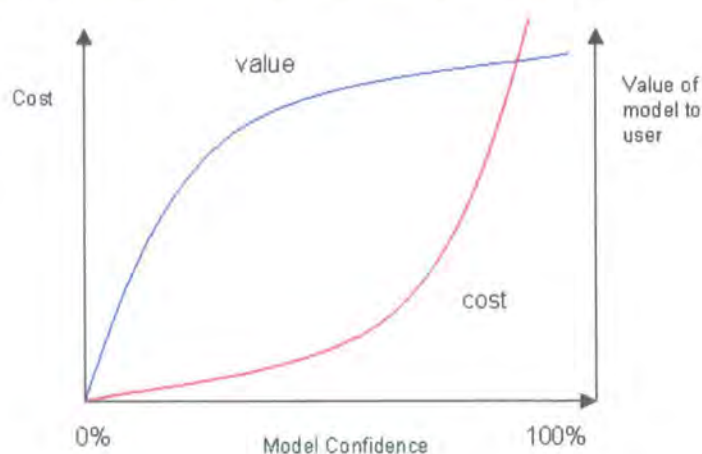

Figure 2-10 Relationship between User Value and Confidence

LITERATURE REVIEW

The list in Appendix C, Figure C-2 by Centeno and Carrillo (2001) shows the various techniques for model validation

2.2.18 Conclusion

In conclusion simulation is an essential and powerful tool in today's manufacturing sector. It allows the user to see quickly and accurately whether a product or schedule or factory layout is viable. It is cheaper than doing the change and then discovering that it will not work and perhaps costing the company millions. Simulation should be included in the design process from the start and not just be seen as a tool used after the event to confirm things.

This review has demonstrated the benefits that simulation could bring earlier in the scheduling and forecasting process and in the understanding of subjects such as factory layout and production flow. The use of spreadsheets is often enough and the best method for simple projects that do not have lots of variables. With more complex scenarios the time to prepare calculations and make changes to the spreadsheet increases dramatically. Whereas with a well designed simulation, the inputs and parameters can be changed repeatedly to refine the model outputs without as much effort. This is why this research is considered significantly valuable to industry. Optimising schedules can be a laborious task, especially with spreadsheets. Simulation can cut this time immensely and provide the user with the ability to disseminate the results after each model/schedule change and validate the model during construction using techniques such as dummy buffers.

Before choosing the simulation software package for this research, there needs to be a further survey carried out into what companies look for in a simulation software package. It has been found that companies are often too busy or reluctant to reply, so the survey must ask relevant questions and be short and simple to complete. Asking companies what they wanted would allow them to purchase the software package most suitable to their needs and be more confident in its use and the results produced.

LITERATURE REVIEW

This review has highlighted the importance of simulation modelling techniques for both new and current in service product and process designs. Whether they are for one off projects, batch jobs or flow shops as shown in Figure 1-1. Using a DET framework, the lead-time of projects can be significantly reduced by increasing the sharing of data and increasing system flexibility. Modelling confidence needs to be enhanced in order for the technique and its results to be more widely accepted across industry. In a lot of companies, as shown by Perera (2001), the current operating environment and way of working is not as effective as it could be in terms of new product and process introduction, and the confidence in modelling is also low. A lot of work being duplicated, which is extending design and prototype manufacture as well as increasing costs. The research shows the benefits that simulation can bring if the constraints and assumptions are set and agreed at the start of the project. This setting of the model complexity makes everyone's expectations of the model and its results more realistic and more willing to accept them, and reduces the number of changes required later in the design process.

3 Development of Scheduling model and Identification of System Requirements

3.1 Introduction

Before being introduced in the Press Shop, market analysis was used to confirm the need for DES and to decide problems it would be used to tackle. The Literature review has reinforced the need for the model in order to increase the flexibility of the press shop and create the most time and cost efficient schedules. Figure 1-2 shows the importance of this stage of the research, because it sets the scene for all the phases that follow. Decisions made here will affect the accuracy and complexity of the model. Salt's idea (1993) from 2.2.13 says that simple is best is the approach that will be taken, with care being taken not to oversimplify and lose accuracy. This method also allows the inexperienced user to add to the model in phases as confidence increases (Pidd, 1996). Validation and verification is also improved if done at each phase. A cross-functional team was set up to input the important factors for the modelling software package such as cost and support and to decide on the research targets and time scale. A Digital Enterprise Technology (DET) framework for bringing all the parties together and sharing the information and research results was developed as a result of the requirements capture.

3.2 Requirements Capture

3.2.1 User Requirements

An analysis of the current situation in the given environment was carried out. This involved providing a forum, in which potential users and those with a vested interest in the project, could voice their opinions either in person or anonymously via feedback forms. This was necessary to ensure that both sides of the story were heard and prevent bias in the inputs and outputs of the created model. Other techniques used were the interrogation of data available on the Intranet and company archives. This sharing of information is a very important factor in DET.

ANALYSIS AND REQUIREMENTS CAPTURE

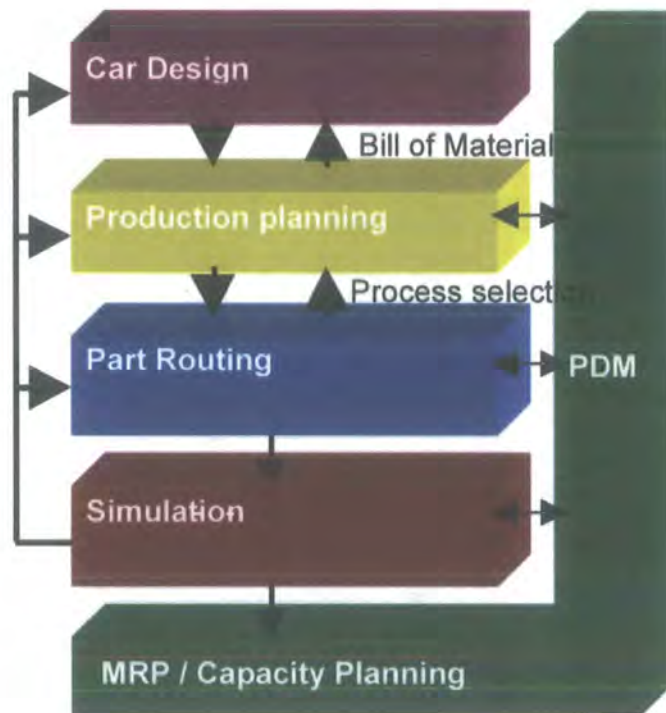

Figure 3-1 DET framework for the press shop model

Figure 3-1 shows how the DET model from Figure 2-1 can be adapted to suit the research. This model aids the planning process and allows the user to visualise how each section of the research interacts and feeds back to the other sections.

This analysis revealed that there is an ongoing conflict in the press shop over departmental targets of efficiency and cost between production (shop floor based department) and production control (office based department) respectively. The decision to use DES to show trade-offs between the two or show one point as being more important than the other was made. Efficiency in the shop comes from larger batch runs and fewer die changes, whereas cost reductions come from having less stock on the floor and therefore fewer overheads, but more cycles and smaller batches, thus creating more downtime. An optimised schedule is required that satisfies all parties.

ANALYSIS AND REQUIREMENTS CAPTURE

3.2.2 System Requirements

In terms of DET, the simulation model is required to feedback scheduling results to Process Modelling and Process Planning to enable the co-development of process models and plans and also to input schedules into Enterprise Integration Technologies as all scheduling information in NMUK must be shared via an MRP system. This system is run shiftly to update stock levels around the plant and create new supplier and in house orders. The data in the MRP stems from a BoM (Bill Of Materials) and the orders created by the sales team and dealerships.

3.2.3 Prioritisation of Areas to be Investigated

The plant currently manufactures three models of car, the Micra, the Almera and the Primera. These will subsequently be called MM, HS and ED respectively. The Press Shop must satisfy the demand for panels from the body shop, service parts and external customers and must produce sufficient stocks of panels to prevent catastrophic stoppages in the body shop. With such demand, it can be difficult to predict and recover quickly from breakdown and shortages. As well as inventory analyses, the identification of bottlenecks was also carried out. After discussion, significant bottlenecks for consideration were found to be the 5000T press and the Laser facilities. These have the longest cycle times and are the only machines capable of running certain parts. This means that in case of breakdown, the shop will be starved of parts a lot quicker than if a breakdown occurred on one of the more flexible lines. Hypotheses regarding shift patterns, breakdowns and capacity need to be evaluated without the added expense of trial and error on the factory floor. Also, with volume mixes going up and down, the DES model may be used for line balancing activities to see how moving blanks or panels across machines effects the lines. Typical volumes are 4200 MM per week, 1700 HS and 1300 ED and 600 Tinos (HM) per week.

3.3 The Industrial Environment

Figure 3-2 shows the flow of parts through the press shop. The diagram shows coils entering the press shop, by road, from a local steel warehouse. Deliveries are made approximately two hours before they are due to be blanked from a local steel warehouse, which holds two to four weeks stock of all parts from the steel mills. Once the coils are blanked (according to a schedule produced by production control) the blanks are stored on the shop floor until they are pressed on one of the six presses. Any tonnage remaining on the coils is put in one of three bays. There are three 2700 T presses (271, 272, 273), two 3200 T presses (321 and 322) and one 5000T press. Some blanks are also sent to one of the two Laser facilities to produce panels not possible from one blank. Both Laser facilities are fed by blanks from Blanking machine number two. The laser blanks are then stored along with the other blanks in front of the presses. After being pressed the panels are sent to 'panel stores' in stillages ready to be consumed by the 'body shop'. Panels may also be used for service or supplied to external customers. Batches of blanks and panels are pressed one to three times per week depending on usage and stillage constraints. Each blanking machine produces around 100000 blanks per week. The Lasers make a combined total of approximately 26000 finished blanks per week. All of these blanks are then made into panels, spending between a few hours to a couple of days in the blank stores.

EXISTING PRESS SHOP LAYOUT

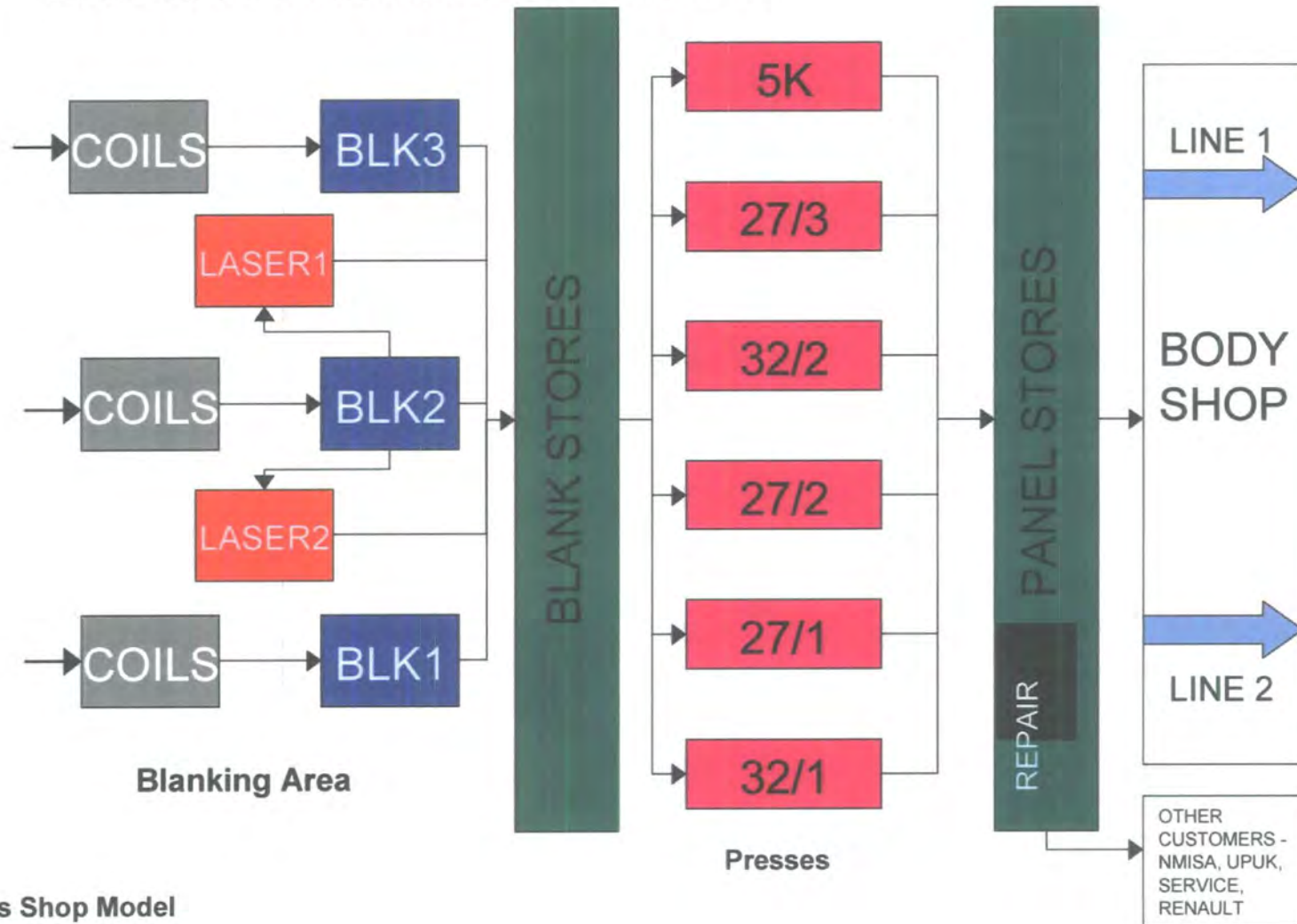

Figure 3-2 Press Shop Model

3.4 Evaluation of NMUK Scheduling Process

At the start of any simulation it is important to set a base level of the current situation in order to find what effects the model would have on elements of the scheduling process. This section presents the results of the analysis carried out at NMUK in Figure 3-2. The process shown describes the flow from the orders being placed at the dealership, to the ordering of steel for the press shop. It shows where a DET simulation tool could fit into the framework. In brief, orders are received from the dealerships across the UK and the rest of Europe. These are fed into Nissan Europe Headquarters and are distributed to the relevant manufacturing plant. Concentrating on the UK plant, most blanks are made in house with the exception of two types from local suppliers. Production planning then produce long and short term schedules, the former based on sales forecast and the latter adjusted according to customer orders. The short term looks at the next 4 weeks and the long term covers the following 5 months.

3.4.1 Planning for Mass Customisation

NMUK operates a system called D-6 (D minus 6) which means that there should only be a period of six working days between the receipt of a customer order from the dealership to the car coming off the end of the production line, which meets all the order specifications. The customer should receive their vehicle within 14 calendar days of ordering it. The percentage of cars made to order is at present 25%, with many of the more popular models being made according to anticipated requirements and allocated as the orders come through. It is expected that, in the future, 100% of vehicles will be made according to customer demand removing the need for vehicles to be stockpiled and the production of obsolete parts. This move is designed to decrease overheads and increase profit.

3.4.2 Proposed Short Term Schedule System

The D-6 window means that the short term scheduling systems have to be accurate and flexible enough to react to changing demands. This research has

ANALYSIS AND REQUIREMENTS CAPTURE

developed DES as an additional scheduling tool to provide decision support to act alongside the MRP system to give rapid answers to scheduling queries and “What If?” scenarios. Crucially, the simulation should be able to identify schedules that could potentially jeopardise the press shop by predicting parts shortages between blanking and press and between press and body shop.

A Bill of Materials (BOM) is produced from the schedules and the demand is seen via the plant-wide MRP system. Once demand has been identified, simulation can be used to determine the effect of the demand on production. The press shop production controllers use the long term schedules for steel ordering (local orders) and the short term schedules to schedule the press, blanking and Laser lines. The simulation will download information directly from the MRP system, based on current stock levels and schedules and then use this information to analyse current short-term schedules and look at proposed ‘What If?’ scenarios.

Figure 3-2, shows how the proposed simulation will fit into the current system. Where simulation is placed in the diagram is in line with Figure 3-1. By employing a DET framework, feedback loops will be set up between the model and the press, blanking and laser schedules. As improvements in the short term schedule are found and bottlenecks are eliminated, this will be reflected in reality in the time and cost improvements realised. The diagram shows that the model obtains its data from MRP sources such as the demand produced by exploding the Bill of Materials. With the plan to use the model to demonstrate the possibility of capacity increases in future months, there is also a feedback loop to the long term schedules. This diagram effectively shows how flexible the simulation will be by using the one model for different applications, including, long term schedules for capacity planning and short term schedules for bottleneck elimination and schedule optimisation.

ANALYSIS AND REQUIREMENTS CAPTURE

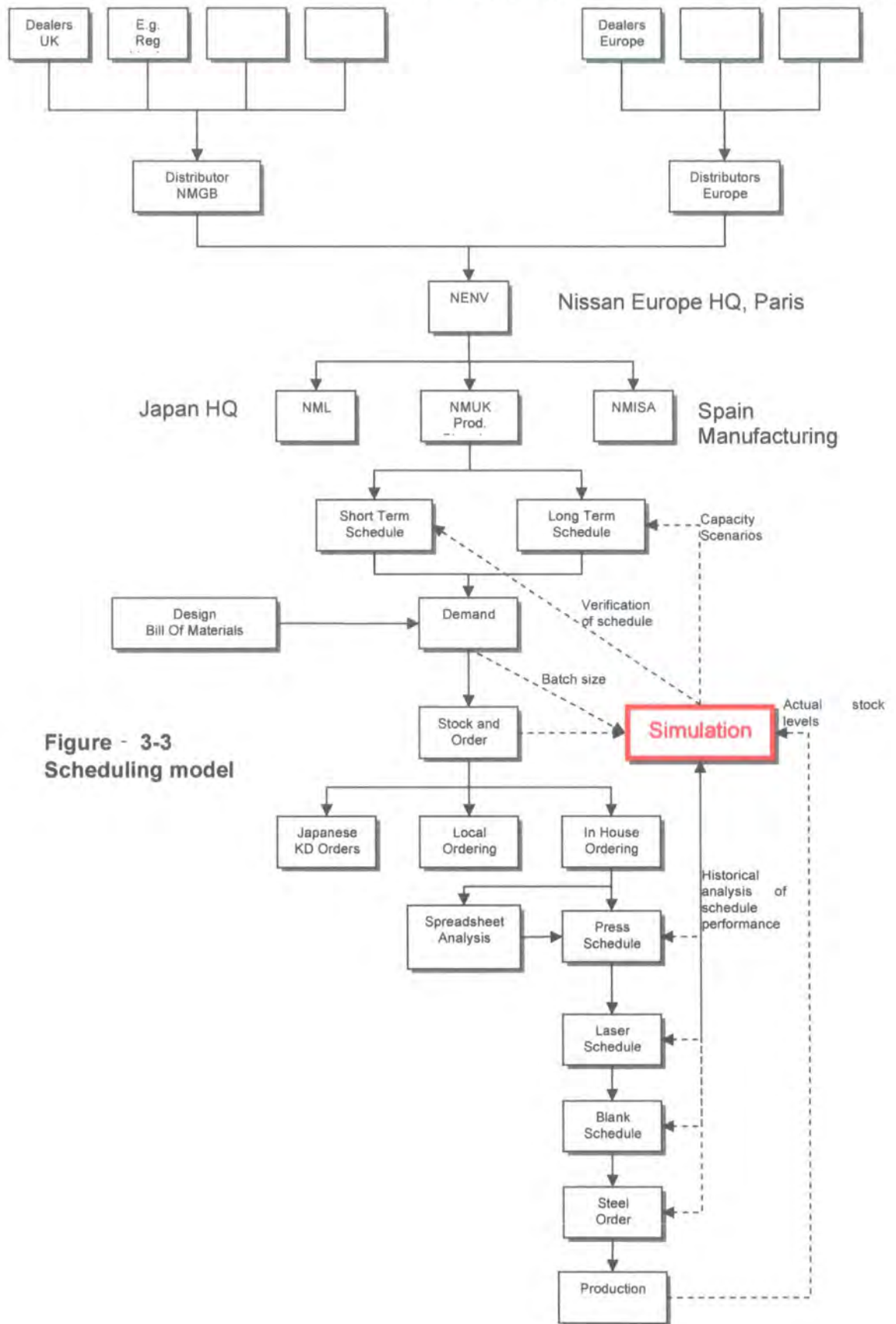

Figure - 3-3
Scheduling model

3.4.3 Conclusions of Analysis

The scheduling processes for short term scheduling in the Press Shop are accurate but would benefit from improvement to the running orders themselves. This means looking at the number of cycles and batch sizes to achieve optimum conditions. The main areas for improvement are capacity planning and inventory reduction. These areas are trade offs between efficiency and low inventory levels. There is scope for simulation in the scheduling framework to be used alongside the current MRP system by using DET techniques to control the flow of data between the relevant systems and company departments.

The novelty of the approach taken with DET lies in the flexible use of simulation software to provide;

- i. Decision support for short term schedule verification
- ii. Optimisation of manufacturing system (reduction in inventory)
- iii. Long term planning via scenario experimentation
- iv. The maximisation of data reuse through integration with existing software systems and ways of working.

3.5 Simulation Software Selection and Benchmarking

The next stage of any simulation research is to evaluate the available simulation software packages and choose the one that will meet all of the model requirements. In order to choose the most appropriate, a benchmarking exercise of the software packages available on the market was undertaken. To complement this a few large companies across Britain that use simulation were sent a questionnaire to ascertain which software packages they use and the positive and negative aspects they have encountered. This questionnaire could be used for any simulation software package research and is not constrained to the press shop model. This would entail amending the weighting of the functionality requirements to suit the intended use of the model.

3.5.1 Functionality Requirements

Initially, it was important to determine the factors that the software packages would be scored against. This information was obtained from interviewing potential users and those who had an interest in the model and results. Figure 3.3 shows from where these requirements have arisen.

From the user's point of view, several functionality requirements and constraints were identified. These are;

- Allow uploads of data from an external source (e.g. Access or Excel).
- Integration of information in DET framework.
- Take into account all of the stated inputs for decision making.
- Allow several (hundreds) of inputs to be processed.
- Give output data in the form of a schedule with running times and accurate shift times. This is in the form of the number of minutes per shift, and allowing for time required for breaks and shift handovers.
- Take into account rules given with certain priorities. For example the number of heavy parts that can be run in sequence for safe working practices.
- Have a function to account for downtimes and trials, have average and ad hoc failures and account for staffing and stillage resource levels.
- Be able to handle parts with several attributes for scheduling.
- Show the parts running through the system at a given speed to show their movement.
- Not be too expensive to allow for more than one licence to be bought.
- Be usable / compatible to other projects in the company.
- Interact with common office software packages for dissemination of results and allow maximum user input.
- Produce inventory reports to show stocks in blanking and press line buffers.
- Allow inexperienced users to be able to use the simulation easily via a simple front end (forms, drop down menus) and without changing set information.

ANALYSIS AND REQUIREMENTS CAPTURE

- Be able to be run quickly to answer queries and 'What If?' Scenarios and also on a regular weekly/monthly basis for the scheduling of item, which result in the creation of a production plan.
- Feedback results using a DET framework to all users.

In order to fulfil these requirements, it was necessary to do research into the software packages available on the market and how academic and company users rate them.

3.5.2 Software package Evaluation

3.5.2.1 The Requirements List

The list of requirements that potential software packages were rated against was drawn up from the functionality requirements in 3.2.2 together with more specific model capabilities. These were extracted from points brought up in the literature review. For example, the use of an optimiser function, this would reduce the man time taken to get the most efficient schedule.

An initial web search immediately eliminated all of the software packages that were obviously unsuitable. (Either they do not have the ability to simulate such complex models or do not have features such as scheduling or interfacing with other software packages for importing and exporting data.) This initial research saved time to look at the more appropriate software packages in greater detail.

Information and demo CD requests from six software package vendors gave the opportunity to evaluate selected software packages in further detail and assess them against the benchmarking matrix shown in Table 3-1. Points looked at include: animation capabilities and interfaces with other software packages, level and cost of support offered, scheduling and optimisation methods. Where further questions arose the vendors were contacted again to obtain further info and advice. The most important points, as highlighted in the matrix are cost and the

ANALYSIS AND REQUIREMENTS CAPTURE

support service provided (both for training and after sales). Secondary points were the interface with other office software packages, especially Excel, the ability to monitor WIP and throughput of parts and scheduling. The others were seen more as nice to haves that would improve model capability.

User questionnaires were also distributed to obtain a more personal point of view and an unbiased opinion on the usability of the software. Users from various sectors and companies such as Renault, British Airways, BMW and Cummins Engines were asked to get as wide an opinion as possible. Points assessed were the ease of use for simple and complex models, opinion of support provided, updates, value for money and what role the software package plays within the company and how useful it has been. British Airways use three software packages, Witness, Automod and Simul8, the most predominant being Witness. They have a dedicated internal consulting department that creates simulation models with 30-40 users that can use the networked software package at any one time. However the relevance of on line hints is often low and they can be quite difficult to translate into models. Also on the downside is that for the inexperienced user there often is not enough on screen prompting and there can be difficulties linking the models to external software packages such as Excel. BA believes that the software package meets most of their needs and has many invaluable functions such as the documentor and has good speed capabilities.

Renault has 100 regular users of Witness and like BA appreciates and benefits from the good after sales and support service from Lanner. They find that the integration with other software packages is average and that Witness is better for creating simple models than complex ones. Both companies have special deals with Lanner regarding licenses and training which is competitive. A copy of the questionnaire used is provided in APPENDIX B.

With Witness already being used within NMUK, it was possible to get the opinions of regular users within the company but it was seen as important to obtain up-to-date information on all the available software.

3.5.3 Conclusion

From the outcome of the benchmarking analysis, shown in Table 3-1, the software packages that fulfilled all the user criteria are Witness, QUEST, Arena and ProModel. Since, several software packages were suitable, the selection came down to other criteria such as cost. The most important points, given the highest priority by the user are cost, a good support service and simplicity to use. This is Quest's main drawback in that it is so expensive and can be quite complex. Witness is a lot cheaper and from the research carried out, was seen as one of the most user-friendly software packages on the market, with a good support and maintenance service.

The selected software package, therefore is, Witness, produced by the Lanner Group. The users questioned believe that it is the market leader and can be used to model almost all types of scenarios. An optimisation and data mining software package is available and graphics are in 2D with add on 3D option. It has the capability to analyse WIP and the after sales support offered was reported as excellent. With the software package already in use at the company, it will be more readily accepted and supported.

Table 3-1 Software Selection matrix

Simulaton Criteria	Using Software System Features/Functions																										
Software		Companies Using it	Info received	Criteria	Cost	Microsoft/Excel Interface	3D capability	Good Support Service	Data Mining	Pull System	AGVS	Acceleration/Deceleration	Stillages	CAD/Factory Design Capability	Operator Movement	WIP Total	Breakdowns	Ability to Specify Process Orders	scheduling	Cash Flow Analysis	Optimiser						
ARENA	Rockwell	Brunel University	student cd and info already got		low	✓	✓	✓	✓				✓		✓	✓	✓	✓	✓	✓	✓	✓	✓	✓	✓	✓	✓
@RISK	Palisade		demo cd and info		low	✓			✓												✓	✓					
AutoMod	Brooks, Autologic	Nissan Japan, Rover	demo cd and info		med	✓	✓	✓	✓			✓			✓	✓	✓	✓	✓	✓	✓	✓	✓	✓	✓	✓	✓
AutoSched					high																						
AWESIM	Frontstep, Symix		demo cd and info		n/a	✓										✓										✓	
Extend	Imagine That	Proctor and Gamble	demo cd and info		med	✓		✓								✓	✓				✓	✓			✓	✓	
NETWORK II.5 and SIMSCRIPT II.5	CACI Products		Access via website		med		✓									✓											
ProModel	ProModel Corporation		journal info			✓	✓			✓			✓		✓	✓	✓	✓	✓	✓	✓	✓	✓	✓	✓	✓	✓
QUEST	Delmia	Renault, Paragon Simulation	Training course attended. Durham have		very high	✓	✓		✓	✓	✓	✓	✓	✓	✓	✓	✓	✓	✓								
SIMUL8	Visual Thinking International	British Airways, Durham University			low											✓	✓								✓		
Taylor ED	Enterprise Dynamics	Michelin	Demo cd and info		n/a	✓	✓	✓				✓			✓	✓					✓	✓			✓	✓	
Witness	Lanner	Nissan, Cummings Engines, Renault,	Already available at Nissan		med for 10 licences	✓	✓	✓	✓	✓		✓	✓	✓	✓	✓	✓	✓	✓	✓	✓	✓	✓	✓	✓	✓	✓

4 Building Simulation Models of Flow Lines for Validating Schedules and Long Range Planning

4.1 Introduction

The following methodology, based on Banks (2000) was formulated to create the simulation model and to integrate the model with the current press shop scheduling system. The main difference between this method and the one by Banks (2000) are that some points have been combined, but all of the elements remain. Setting of Objectives and Overall Project Plan is included in Problem Formulation. Data Collection have been combined and finally Documentation and Reporting has been included in Implementation. This has been done in order to achieve a better research flow. It was found that working on two or three points concurrently reduced duplication of work and increased productivity and users' understanding of what the project was trying to achieve. This was done by discussing related topics in one meeting and getting feedback instead of holding several more protracted meetings covering the same ground. Also for the data collection and validation stages of this revised model, it was vital to create links with existing software. For example, creating downloads from the MRP system of real data to input into the model and validate results against. The original Banks model (2000) can be seen in section 2.2.2. A revised version which suits the methodology used in this research is depicted in Figure 4-1.

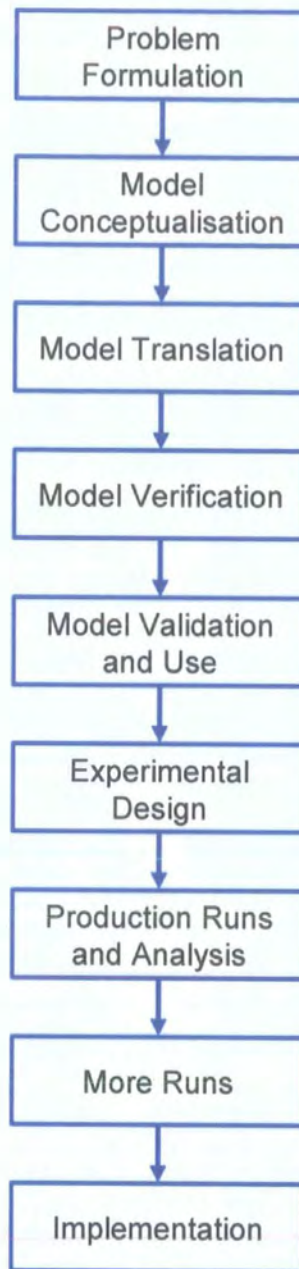

Figure 4-1 Research Methodology

1. Problem Formulation

The scope is the NMUK press shop including Blanking, Laser and Press facilities covering short term scheduling (within a month's horizon) and 'What If?' scenarios that cover long term schedules (5 months). This can be seen in the Press Shop model in Figure 3-2.

2. Model conceptualisation

Ideas and opinions from current users from the shop floor and scheduling functions and senior staff created a project aim and scope by considering all of the constraints, assumptions and inputs that the model would have to cope with.

3. Model Translation

In model translation, the model was created and the data input. Full documentation of the final model and the entities and parts it contains was produced. The model was built in stages. The problems encountered and their solutions are also discussed.

4. Model Verification

The model was verified through its construction against static MRP data. This was done using temporary attributes and dummy buffers that would display the information such as cycle time or part number on screen.

5. Model Validation and Use

In model validation, the results obtained from the model were checked against real data collected from the blanking and press lines over a time period of a week. Further production runs were carried out and the model stopped at various times to confirm the results. How the model is used and integrated with current systems is explained.

4.2 Problem Formulation

The problem was formulated because of the need for improvement in the current press shop scheduling system. Ideas and opinions from current users and senior staff created a project aim and scope by considering all of the constraints and inputs that the model would have to cope with.

4.2.1 Setting of Objectives and overall project plan

MODEL CONSTRUCTION

Every simulation project should have a detailed set of objectives, in line with the overall objective of the project, together with a series of quantifiable metrics. This is to measure the success of the new system at given milestones and of the final results. The detailed requirements for the model were:

- To create a detailed digital model of the press shop including the blanking and press lines
- To reduce inventory in the press shop by reducing WIP and throughput times
- To identify and eliminate bottlenecks
- To validate / quantify outputs
- To train selected users in the use of the chosen software package
- To use the model for capacity experimentation

Quantifiable Metrics and targets

- Reduce cost of inventory in line with company GIR (Global Inventory Reduction) targets to £432,332 from £639,315 at the start of 2003
- Reduce number of day's inventory to 2.6 days at year end from 4.07 at start of the year.
- Accurately as within 10% test the shops capacity, with outputs checked against real system data for targets such as inventory and throughput.
- Have no user intervention during model run time ensuring that coding outputs required results.

4.3 Model Conceptualisation

This is the process of turning ideas and visions into the basis for a simulation model. This was undertaken in the form of the diagram showing the flow through the press shop in Figure 3-2.

Due to the complexity of operations within the Press Shop, numerous assumptions and simplifications had to be made, trying not to influence the accuracy of the produced results. These points are explained in 4.3.1

4.3.1 Assumptions

During the early stages of model conceptualisation, it became obvious that the model would be too complex to build and slow to run if all of the available information were included. The following assumptions were made in order to simplify the model and eliminate unnecessary detail. This is a good idea but care should be taken not to oversimplify and lose accuracy. As Pidd (1996) suggested in 2.2.13 it is better to start simple and add to it. This way the user can assess at each stage the validity of data and whether it adds anything to the model. For further schedule investigations it may be desirable to ignore the assumptions stated here. If this becomes necessary it will be stated. For example a change the shift patterns and overtime that is assumed excluded in assumption 2 would allow for major capacity increases and more flexible work patterns.

Assumption 1 – Assume constant availability of coils

If this is true, the inclusion of coil numbers in the model can be ignored. This will reduce the number of parts in the model by approximately a quarter. This assumption is simulated by having buffers that can hold up to 300 parts and are continuously at maximum capacity. This method also saves pre fill time at the start of the model execution and allows the user to ignore blank weight as it is not needed to calculate the number of blanks from a coil anymore.

Assumption 2 – Assume a normal working week

This means the inclusion of shift patterns and breaks during a normal week. It is assumed for normal model running that weekends are not included

Assumption 3 – Ignore SNPs (Standard number of parts per stillage)

It is assumed that this detail would have negligible effect on the model structure and would not greatly affect the results.

Assumption 4 – Assume availability of stillages

MODEL CONSTRUCTION

This means that although stillage movement is ignored it should still be remembered when making large or critical parts that there is limited space in stores. Run sizes should be kept realistic.

Assumption 5 – Ignore transport data

This is similar to the assumption of coil availability and is a detail that is outside the scope of this project.

Assumption 6 – Ignore Blank Wash facility

The blank wash can be ignored because it is an unnecessary consideration for the purposes of schedule production and would only affect production if blanking and press runs for the parts that need washing were too tight. Therefore the time to carry out this task can be ignored.

Assumption 7 – Ignore staffing levels

Assume that there is the manpower available to run four out of the five blanking and laser facilities and two out of three of the '2700' presses as well as the 5000T and the two '3200' presses.

Assumption 8 – Ignore transport around the shop

Because of the lead-time between press and blanking, the time to move parts around the shop is negligible.

4.3.2 Constraints

These constraints are set by the shop currently and are included to minimise die changes and set up times

- Some parts (Left and Right) are run from the same coil on the same die. Therefore to minimise die changes they should be run together in the schedule.
- A minimum run size should be > 400, this is because it takes 45 minutes on press and 15 minutes on blanking to set dies and coils so the previous run

MODEL CONSTRUCTION

needs to be long enough to ensure that the line does not incur needless downtime.

- All Laser parts run on Blanking 2. This is a constraint due to the required dies not being available on the other two blanking lines.
- Rotate shear parts can only be run on Blanking 2 or Blanking 3 as Blanking 1 does not have the correct die facilities.
- At least 8 hours of inventory should be kept at in the panel stores to allow for line side stocks. This is to ensure that body shop has at least a shifts worth of stock available to cover for delays in the press runs and any scrap that may occur.

Another constraint is the fact that the model represents a brown field site with particularly heavy machinery. This means that the shop layout can not be amended to try and improve product flow and increase shop capacity. If it were a green field site, this constraint would not exist and it may be possible to improve on the results from this research. This would be in areas such as time for die changeovers and coil loading, by changing where tools and materials are stored in the shop.

4.4 Model Translation

Before actually building a model, it is important to identify all the relevant data and information as described above. It may not be necessary to collect it all at this stage as the requirements may change or the data may become obsolete. It is important however, to know where it can be obtained, either from reliable sources, for example if somebody has collected it previously or through experimentation by the model builder.

This section describes the translation of the collected data into the actual simulation model. The model was built up in stages, starting with just one blanking machine and one press machine and ending with a representation of the full Press Shop.

4.4.1 Data Collected

The data collected for these points is given in APPENDIX D. The majority of the data was obtained either from shop floor or office based users from their experience of the machinery, current MRP system and schedules. The rest was researched from press shop archives.

- Number of coil loads, recoils, quality checks, run outs and time to perform, to create a distribution for an average number of operations before each is required.
- Number of die changeovers and times, as above to ensure that the correct distributions are used in the model
- Time availability on each line – shift patterns, lunch breaks, down times. This is very important when faced with labour shortages
- Total number of parts and number of each part required, batch sizes and weekly volumes.
- Safety stock levels – 8 and 10 hours, so that a part never stocks out and body shop can always be supplied.
- Number of parts that determine frequency of blanking and pressing.
- Parts that go together – Right and Left parts, A and B spec of the same part.
- Parts that need to be lasered, in order to prepare the laser schedule.
- Which die sets are fixed to which machine to decide about line balancing for future schedules?
- Extract scheduling logic, for example when production levels mean it is advantageous to have two/three runs instead of one
- How parts are tracked through the production process Average strokes and blanks per minute for each part and each machine, to get time required to process.
- Which coils go onto which blanking line and which blanks can go onto which press line?
- Which parts can be commonised on a coil (without compromising on quality)? Important when scheduling the blanking lines, to use parts with the same coil

straight after each other where possible to reduce coil movement and coil threading time.

4.4.2 Obsolete data

The following is a list of data that, at the start of the project, was considered important, but due to constraints and assumptions was made obsolete. It may be important for future research, so they are worth mentioning.

- The number of coils as mentioned became unnecessary when it was assumed that coils would always be available.
- Blank weights. This may be used in a future exercise to decide on the best coil sizes for different parts. As the coil availability was assumed constant, this point also became obsolete.
- SNP for each part and number of stillages available and which parts share stillages. Not important for this project as it is assumed that for what if scenarios that stillages will be available and sourced if necessary.
- Transport data for the delivery of coils and blanks from suppliers. It is assumed that there is a constant availability of coils from suppliers and the orders for the blanks are met.
- How long parts take to blank wash. This point has not been considered in the model as it would add an element of unnecessary data.
- Which parts are commonised to which coil. Only important if dealing with coil data.
- Sizes of machines and the paths of parts. Only important if movement around the press shop is to be considered. Not in the scope of this project and What if scenarios, but may be looked at in the future.
- Mean Time Between Failures (MTBF) for machines, average number of pulled runs. Not considered significant as it is only a problem in major breakdown situations, which would have to be modelled accordingly.

MODEL CONSTRUCTION

- Repair times for machines to decide whether to set this as a distribution. Again, this is only important if a major repair is required in the case of a facility breakdown. This would be considered as a 'What If?' scenario.
- Scrap and reject rates to decide if this is an important factor in the model. This would complicate the model too much. This figure is very low and with the model volumes being reduced by a factor of 100 the scrap rates become negligible.

4.4.3 Model Entities

These are the buffers, machines and parts that make up the model. This is a description of each entity used and what it does. See Shop Model to see where the following descriptions refer to in the press shop flow.

4.4.3.1 Coil Bay Buffers

The model has three coil bays as buffers with a capacity of 300. Each coil bay is dedicated to feed a Blanking machine. There is no other information in the buffer as the decision was taken to assume that the coils were always available for the blanking lines.

4.4.3.2 Blanking Lines

There are 3 blanking lines, 'Blanking 1','2','3', and these are represented by single machines. They read schedules in from external text files. The data they read in are 'Part number', which is generic and is 'panel'. This is to minimise the number of actual parts in the model. All part numbers used are attributes of the Witness parts, panel. Next is the blanking line the part is made on, the batch size of the run, the blank number that is the attribute of the part panel. This is a number used in the actual press shop for the type of blank. E.g. 73112 AX30B is the blank for a Micra roof. Next is the cycle time required to make one part, the die set that is used to

MODEL CONSTRUCTION

create the part so that extra set up time can be put in if the die set is different than the previous part's, the storage area that the blank needs to go to. For the purpose of the model, each press machine has its own blank storage area so as to minimise the size of the buffers. Finally the information concerning which model of car the blank is for is given. MM, ED and HS are the codes used in the press shop. Keeping as much information as possible the same, means that downloads are easier to translate into the model and results are easier to understand not only by the user but by those that the information is being reported to.

Two counter systems are used by the Blanking machines, firstly to ensure that the quantity made matches the batch quantity read in from file and, secondly, so that when the number of lines read in from the file matches the required number, production will stop and the machines active and idle times will be correct. The machines use simple rules to pull raw material from their respective coil bays.

Each blanking machine uses three set up times. The first is for coil threading, when a new coil is brought to the line. This is set to happen every 150 operations and uses a time from a distribution input into Witness from historic data from a database. The second is die change, this relates to the information read in from the external schedule file and again the time refers to a continuous distribution. Finally, there is a quality check set up operation. In reality this happens whenever a new part batch is started and the time also refers to a distribution from historic part data. Each blanking machine uses its own shift pattern. At any one time it is only possible to run a maximum of three out of the five Blanking and Laser facilities due to manpower availability.

4.4.3.3 Laser facilities

There are two laser facilities in the model, 'Laser 1' and 'Laser 2'. 'Laser 1' is perhaps the more complex because it processes fifteen different types of Laser blanks whereas 'Laser 2' is dedicated to only one or two products. Each Laser

facility is modelled as an assembly machine because a Laser blank is made up of two or three blank parts.

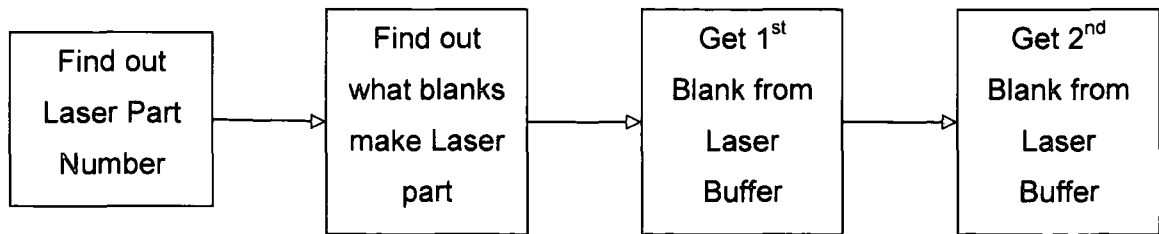

Figure 4-2 Laser Match Condition

Figure 4-2 shows the algorithm for the input rule for Laser1. Each of the fifteen laser blanks requires a similar procedure. The rule is used to match the laser blank number 'Las1type' with information from the schedule, which is read in from a text file and will pull two blank parts from the Laser stores buffer that match those given. As an example for this condition, the Laser Blank number is A765327MGAS and the two blanks that make up that part are A765324M7UB and A765324M7GB. Laser 2 uses the same rule but pulls three blanks in total from the buffer.

The laser facilities read in schedule files in the same way as the Blanking machines. The data includes the Laser facility name (i.e. Laser1), the batch size of the run, the Laser blank number, the cycle time per part and which store the parts need to go to be used by the presses. Both Lasers run to their own shift patterns so that, as mentioned earlier, only 3 facilities run at any one time.

On output from the Laser machines, parts are given a time stamp of when they were made, this is so that the time between production and use on the press can be recorded. The blanks from the ordinary blanking lines have a similar timestamp process to make it possible to see the time between blank and laser blank and the time between blank and press. When the model is run, the timestamp information can be exported to an external data file and used to first determine the time inventory spends on the shop floor. In the press shop, this is termed the 'offset', and is an important measure, which is part of Nissan's Global Inventory Reduction (GIR) targets.

4.4.3.4 Buffers

There are six buffers between the blanking and Laser lines and the press lines, one for each press, each having a capacity of 50000 parts. In reality, the shop floor is used as the buffer, but by designing the model to have six smaller buffers there are fewer parts to search through when a part is called from a press line. This means that the model runs quicker. When the model was tested with only one buffer, the simulation ran for 20 minutes without much headway being made into the schedules. Using six buffers it is possible to run a schedule all the way through in a couple of minutes. The buffers are sorted by attribute (blank number) to increase search speed even further.

There is a function in each of the buffers to record, to an external file as shown in Figure 4-3 if stock of a part in the buffer exceeds a predefined value. In the model this is set to be 4000. This uses local variables so as to take up less processing power in the model.

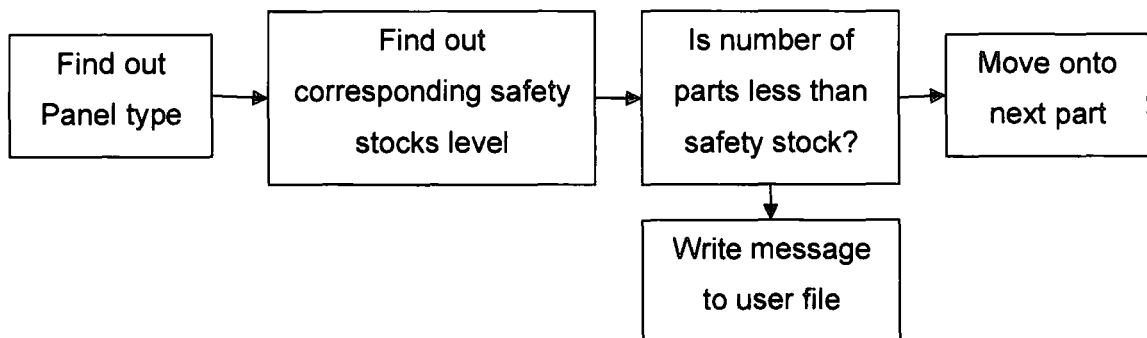

Figure 4-3 Parts going below safety levels

A user action has also been programmed for these buffers; Figure 4-4 displays the total number of instances of a part that are in the buffer at a particular time. The

MODEL CONSTRUCTION

model can be suspended at any time and when user actions are requested, the part number attribute of each part in each of the buffers is exported to external files. This function goes through every part in the buffer in sequence and reports their value. The total number of parts is also recorded. This information is used for looking at inventory at different times in the weekly schedule.

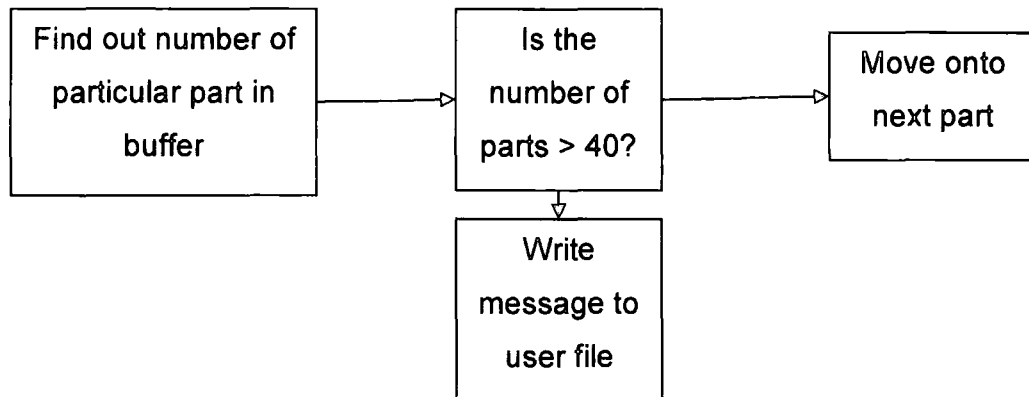

Figure 4-4 Parts going over maximum levels

4.4.3.5 Press Machines

Each Press machine is modelled as a single machine ('271', '272', '273', '321', '322' and '5k') with one part being pulled in and one part produced. The machine pulls parts according to an external schedule, from its buffer stores. This involves using the match rule where the blank in the buffer is matched to the one in the schedule. After being called into the machine and processed, its panel number attribute is attached to the part. The information read from the external schedule file is the part name (panel), the panel number attribute, the blank number attribute, the press line the part is running on, the batch size, the cycle time per part and what type of part it is (e.g. MM 3DR). As with the blanking machines, when a new batch is started a message pops up on the user screen telling the user which part has been started on which line, the size of the batch and the time it started.

There is an additional die change time associated with set-ups for each new blank type. When the model detects a new part attribute, a normally distributed delay is

MODEL CONSTRUCTION

applied. The length of this delay was determined from historical data. The times for these delays is shown in APPENDIX D. Each of the machines also has its own shift cycle that reflects the actual shift pattern used in the shop. This makes waiting between blanking and press as accurate as possible. There is another timestamp function on each press machine. This is put together with the time into press buffer information and the results exported to an external file. This allows the user to analyse offset information between when a part is blanked and when it is pressed.

The parts are then pushed to a buffer, which represents the body shop stores. Six separate buffers are used, again to reduce the time the simulation spends sifting through vast quantities of parts. The parts are stored in the buffer ordered by attribute. The attribute used is now the panel number because this is how they are represented on the body shop systems.

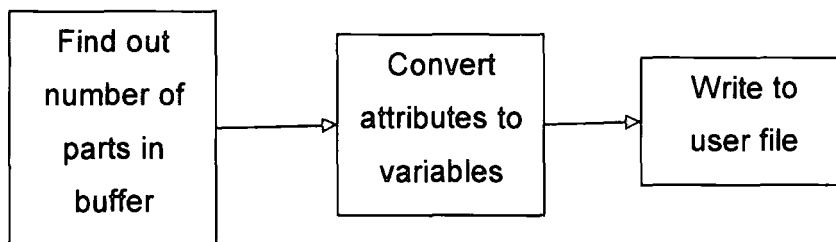

Figure 4-5 Number of parts in the buffer

Local variables (lines starting with DIM) are used in the example shown in Figure 4-5 in actions on output of the buffers to alert the user when stocks are getting low on a part. For example the part type of ED which is a common Primera part is quite high user so the user will be alerted when there are 3 (equivalent to 300) parts left in the buffer. ED 4 Door parts are a lower user and so have a lower safety stock point. When a part goes below its safety stock level an alert is written to an external file which can be viewed by the user at the end of the simulation.

These buffers also have the same function as the press buffers, which allow the user to suspend the model at any time and run user actions to discover which parts are in the buffer, and of what quantity. The buffers have a capacity of 40000 parts.

4.4.3.6 Body shop

The Body shop is represented by six batch machines, one per press, again to reduce running time of the model. The batch size of the machine is dependent on the schedule being read in. To simplify the model, the body shop only pulls parts for the presses' output buffers at the equivalent of the beginning of every day shift. In reality the Body shop would be a continuous user, removing parts from stores during day and late shifts, but because batch sizes have been reduced by a factor of 100, it would be difficult to show the low user parts being removed. It would also require some long schedules and unnecessary time to work out when a part should be taken from the stores, especially if volumes and build mixes changed. Instead, it is easier to have a generic schedule to represent the daily consumption of parts by the Body shop that is easy to adjust and takes a cycle time of 1 minute once per day.

This does mean however that some accuracy is lost in the model. Some parts pulled into the body shop are low user and may only need twenty panels per day. The minimum they can take is 100 because of the batch sizes being reduced by a factor of 100. This affects the stock levels in both buffers and the model may experience more stock shortages in the 'panel stores' than happens in reality.

The Body shop schedule file that is read in contains data on the part name (panel), the panel number and the batch quantity. The machines run to body shop shift patterns, which are day and late shift. Unlike the press shop they do not run a night shift. There are no set up or breakdown patterns on the machines and it is not possible to measure idle and busy times because of the forced timings of taking batches from the stores. Once parts have passed through the Press Shop, they are then pushed to buffers so it can be monitored if the right number of parts have been used and easy to track if there are any problems with supply.

4.4.3.7 Model Warm-up

To fill the model with up-to-date shop floor information on current work in progress (WIP) levels, a part file is used to read in an external text file and fill the buffers at the beginning of the simulation run. The data comes from Nissans MRP Mainframe. This method of integrating actual MRP data into the model can be thought of using the DET model. The results fed back to the user are then as accurate as possible.

Also on starting the simulation, the first lines of the following files are read in. These correspond to the schedules called from the blanking, laser, press and body shop (consumer unit) files.

- Blanking 1 schedule, Blanking 2 schedule, Blanking 3 schedule
- Pressline 271, pressline 272, pressline 273, pressline 321, pressline 322, pressline 5K schedules
- Laser 1 and Laser 2 schedules
- Bodysshop schedules for 271, 272, 273, 321, 322, 5k facilities

4.4.4 Building Large Models

As predicted in the literature review, building large models with high complexity can create many problems. The following section gives a brief description of the main problems faced throughout model building from the initial model up to the final model, used in testing, with all six press lines, three blanking lines and two laser facilities. All of the problems encountered are generic and could occur in any modelling project. The solutions provided are an example of what was used for this model and are not the only options available but were thought to be the best for this application. In APPENDIX E is a more detailed breakdown model revision by model revision of what has taken place.

MODEL CONSTRUCTION

Problem 1 – Routing parts through the model is time consuming and complicated.

Solution – Initially, the Witness 'route system by part' command was used. (A pre-defined Witness program). Problems with routing through the buffers were encountered as Witness does not recognise buffers as machine locations. Hence, the method of routing each part was changed to using the 'To' and 'From' rules on machines. This quickly became impractical as the number of different parts in the model increased, as the amount of coding required and the associated risk of error also increased. Using a part attribute system, as explained below, meant that part routings could be encapsulated in an external file and read in line by line as the model progressed through the schedule.

Problem 2 – Too many parts are referenced in the model

Solution – It became more and more apparent as the model increased in size that it would be cumbersome and difficult to change part attributes if they were all listed in the model itself. Instead, as much information as possible was stored in external files. These are easier to maintain and can be updated with changes made in Access or Excel. A number of part numbers can then be associated with one PART in Witness. For example in the model, 'panel' is the PART in Witness and this is referenced in all the external files and has attributes and variables associated for all the necessary part numbers (e.g. A76022AX60B). Each part number then has attributes such as cycle time, batch quantity, panel number, blank number, which machine it is made on, which store it needs to be shipped to and die set. To have all this information in the model itself would make it large and slow to run, which is the next problem.

Problem 3 – Model Execution Speed

Solution – The model was taking twenty minutes plus to run through a schedule. When this was increased to six schedules it would have resulted in unacceptable run times, making it difficult to make changes and quickly see their effects. The

MODEL CONSTRUCTION

main problem was traced to the quantity of parts running through the system (several thousand in each buffer). To overcome this, several measures were taken.

1. The coil bay buffers were limited in size and are constantly refilled when parts are taken out. This saves several minutes in the warm-up section at the start of the model.
2. Batch quantities were first divided by ten and the cycle times multiplied by ten to counterbalance the effects on accuracy. This meant that there were ten times fewer parts in the model at any one time. The full six press schedules now completed in 20 minutes, a vast improvement.
3. To improve further, the batch sizes and cycle times were divided and multiplied by ten again respectively. The model now runs through completely in 1½ minutes.

These changes may have some effect on model accuracy, but it was decided that the effects were an acceptable trade off against the running time of the model.

Problem 4 – What type of machine to choose?

- The laser schedule

Solution – The laser machine needs to pull in two different parts and produce a single new part type. The problem with this was what coding to use. It was decided to use a production machine and the MATCH/CONDITION rule in Witness. Another possibility may have been to use an assembly machine but the coding would have been more complicated.

4.4.5 Model Verification

Throughout model build and pre-experimentation, verification and validation procedures were undertaken. For example, dummy buffers were set up to monitor the paths that parts take and to check that the batch sizes and cycle times were correct. Temporary attributes were also set up and displayed on screen for the same purpose. As a final confirmation, DET was used to validate the model with an

MODEL CONSTRUCTION

actual week's schedule. This meant that outputs, such as total time, idle time, set up time, cycle time and model type of each part attribute, could be compared with the actual results from the mainframe MRP system. The total time was set against the week's schedule, batch sizes were checked against static data.

4.5 Model Validation and Use

4.5.1 Validation

It is important to validate the model at all stages including model conceptualisation. This means that the user is confident in the outputs of each entity and provides a plan of how to build the model in phases. Figure 2-9 by Hu (2001) was the method used to validate the press shop model. By having an idea of how the model should look and the type of outputs expected it was easier to build the model and not waste time testing every entity at the end of the research to find out where errors were occurring. By isolating sections of the model and introducing dummy buffers, it was possible to perform program walk throughs and test the model under different conditions.

Table 4-1 shows a comparison of the model results against actual results taken from the lines at the end of June (week 27 at 2 am on the 1st July). The actual data is extracted from financial reports and shows the stocks of coils, blanks and panels in the Press Shop at that particular time. The same timings were used to stop the model and run user actions and export results to external text files. The results were then manipulated as described in Chapter 5.

MODEL CONSTRUCTION

MODEL	INVENTORY								
	TIME	BLANK VALUE £			BLANK STOCK (DAYS)				JUDGEMENT
		WITNESS	ACTUAL	VARIANCE	WITNESS	ACTUAL	VARIANCE	%AGE	
MM	2am	162520	192007	29487	2.24	2.41	0.17	7.00	OK
HS	2am	149895	167046	17151	3.13	3.22	0.09	2.80	OK
ED	2am	92340	97017	4677	4.25	4.48	0.23	5.10	OK

Table 4-1 Model Validation Table

The variances are minimal for the number of day's stock as highlighted and show how accurate the model is compared to actual data. The variance for the number of day's stock is 7% and value difference is £29487 overall. This is well within the quantifiable metrics of the research. Discrepancies of £30000 can be explained by stock which is on hold. The GIR figures take this stock into account, whereas the Witness model does not.

4.5.2 Downloading Production Run Data

The model uses real time shop floor data, which is obtained by downloading current stock levels from NMUK's mainframe into Microsoft Access and then exporting this file into Excel. This enforces the use of DET. The files are then formatted and saved as text files ready to be read into Witness. Lookup tables are used to provide the correct data for Witness to use. For example, the part type which the part number relates to and which blanking line or press line buffer or finished panel stores they were put into are obtained from Lookup tables.

Depending on the experiments, schedules are either obtained from NMUK's MRP system into the Excel schedules or a generic schedule is used and the overall ED, HS and MM figures input. Excel then changes all the model variant quantities in the spreadsheet. The schedule files are saved in the same folder as the model, as text files ready to be read into Witness.

4.6 Conclusion

The chapter has described a generic method for use when developing any simulation model. From formulation through to model use, all problems that have been experienced and their solutions that have lead to the successful validation of the model are described.

It is very important to state the assumptions that are made in the model so that users can assess the accuracy of the results for their specific purposes.

Also documented is the data that was collected for the model inputs and the entities and their attributes, so that a user can recreate building the model. This is also important so that a user can go back to the model at a later date and understand why decisions were made.

The validation of the model is very important because it sets the confidence level of the model for use in future scenarios. It is extremely pleasing to see how accurately the model reflects real life results. With respect to the press shop model, all of the car models are within 7% of the actual results. This is an excellent platform on which to begin the experimentation phase.

5 Experimentation and Results

5.1 Introduction

The results shown in this chapter are indicative of the incremental experimental procedure described in the adapted use of Banks' model (2000) depicted in Figure 4-1. In some cases several runs of the model are used to investigate the scenarios and experiments for long and short term schedules. The charts and tables are provided for each stage to best show the effects of the changes made and how they compare to previous results. The points considered are described below;

1. Experimental Design

This is concerned with the design of the experiments undertaken and the processes involved in improving the schedules. There are two main batches of experiments, the first batch are concerned with inventory and cost reduction on the shop floor without a detrimental effect on efficiency. The second batch of experiments looks at future volumes and capacity of the lines in the form of 'What if?' scenarios.

2. Production Runs and Analysis

This describes the inputs into the Inventory Reduction experiments and the analysis of the results obtained. Charts are used to show the improvements in inventory over a period of eight weeks.

3. More Runs

This section shows the full potential of the model when used for 'What If?' scenario experiments. Three experiments are carried out and their results analysed and improved.

Documentation and Reporting is discussed for each Scenario.

4. Implementation

A brief description is provided giving an explanation of how the model will be rolled out and used within the shop. The expected benefits are also discussed.

5.2 Experimental Design

The data generated during a Witness model run is exported into Excel for analysis. To measure the offset and blank and panel inventory levels, pivot tables are used. This gives flexibility for obtaining a wide range of results depending on the experiments objectives. For example, the results can be sorted according to which blanking line a part runs on or which part type it is (ED, HS, MM). The data can also be displayed graphically.

A set of tables has been created for use when running an experiment. The tables can be used to compare the results obtained against pre-set targets. The user then decides whether the obtained result is acceptable (ok), marginal (marg) or no good (ng) and can decide on corrective action for the next model run. These tables were used extensively in evaluating the outcome of the 'What If?' scenarios.

5.3 Production Runs and Analysis

5.3.1 Inventory reduction

Global Inventory Reduction targets (GIR) are set annually by the head office in Japan for each plant around the world. The plant's progress towards these targets must be reported back at the end of every month and discussed at management and director level. The figures monitored are the value of coils, blanks and panels on the shop floor at the end of month and the number of day's stock this relates to. The figure is worked out for the coils, blanks and panels and then a weighted average calculated. This is necessary because of the difference in volumes produced for each model. To work out the weighted average number of day's stock, points considered are the number of working days in the next month and the predicted value of the stock on the floor for the next month. The stock on the floor

EXPERIMENTATION AND RESULTS

prediction comes from the value of the individual blanks, panels and steel multiplied by the volume required for each model.

The calculation is; weighted average number of day's stock =

(Total forecast cost of production for next month / number of days in next month)

Total blank value at end of current month

Table 5-1 below shows the finance results taken from end of month. It can be seen that by the end of August, the shop was well within its targets.

Charts to show this data are in APPENDIX F.

		Jan	Feb	Mar	Apr	May	Jun	Jul	Aug
M/E stocks	ED	148887	142940	132216	118516	111893	97561	97017	92035
	HS	206186	237793	206383	198562	190837	174507	167046	153309
	MM	284242	237662	178346	215989	188610	192104	192007	199573
	TOTAL	639315	618395	516945	533067	491340	464172	456070	444917
Days stock	ED	4.91	3.96	5.47	4.62	5.03	4.48	2.81	2.66
	HS	3.12	4.05	3.31	3.24	3.49	3.22	3.62	3.32
	MM	4.68	3.74	2.96	3.36	2.48	2.41	2.51	2.6
	Weight avge total	4.07	3.9	3.52	3.53	3.21	2.98	2.9	2.83
	Weight avge target	3.8	3.8	3.6	3.6	3.35	3.35	3.3	3.3

Table 5-1 GIR Targets

Between calendar weeks 20 and 28 (mid May to the end of July), there were significant schedule changes on the blanking and laser facilities, which gave the opportunity to rigorously test the Witness model. During this time, blanking and press runs became more synchronised so that they ran closer together. This means that at any given time, the blank inventory on the floor was reduced. This monitoring process was carried out during the eight weeks leading up to factory summer shutdown 2003 and the results of inventory at the times of 1 minute, 4000 minutes and 8000 minutes into the schedule recorded. The offsets between the blanking and press facilities were also recorded as well as alerts when stocks reach maximum and minimum levels in the buffers.

EXPERIMENTATION AND RESULTS

Using the model meant that inventory levels and offsets between blank and press runs could be taken on a weekly basis instead of just monthly as was done previously via the end of month downloads and financial reports.

5.3.2 Results of inventory experiments

The experimentation procedure was carried out on a weekly basis and below are the charts from the beginning, middle and end of the experiment timeframe. The rest of the charts to show offsets are shown in Appendix G.



KEY – Blanking Line 1, Blanking Line 2, Blanking Line 3

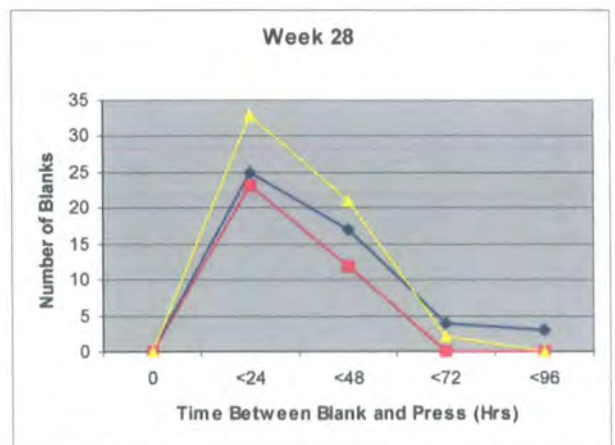
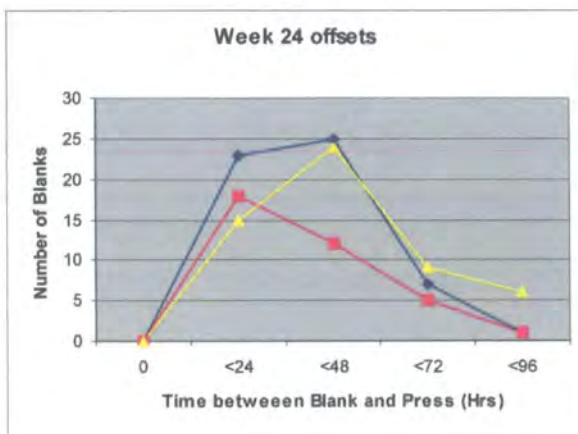

Figure 5-1 Offset charts for Inventory Reduction Exercise

EXPERIMENTATION AND RESULTS

From the charts it is easy to see the improvements made in stock holding across all three blanking lines. In week 20 there were more than five blank types per line that were being held on the shop floor for between 72 and 96 hours. This amount of stock is unacceptable particularly if they are heavy user or high value parts. By week 24, only Blanking line 1 still had this problem. It can also be seen that there was a major shift in the range of the results, showing a normal distribution, especially for lines 1 and 3. By week 28, the desired results had been achieved and even exceeded for inventory and cost of stock holding. The results were dramatic, with the cost of holding inventory being reduced from £639,315 at the start of 2003, to £444,917 at the end of August 2003. This is on target for the end of year figure of £432,332. The number of days holding has been reduced from 4.07 at the start of 2003 to 2.83 at the end of August. The system will be used to ensure that the end of year target, of 2.6 days is met. All of the charts follow the same trend. In week 20 a lot of parts were on the floor up to 48 hours. By week 28, this had changed to 24 hours or less. This is an excellent achievement in monetary terms. It means that there is a lot less inventory on the floor and so less WIP. It is a saving of 30%. If the techniques are continued to be used, benefits such as those experienced with DFMA (average of 50%) could be achieved.

5.4 More Runs - What If Scenarios

There were three different 'What If?' scenarios used to test the flexibility and usability of the model. All scenarios were concerned with volume changes that might occur in the future in the press shop. Table 5-2 shows the scenarios examined.

For each scenario, a generic schedule was created in Excel from an average recent stock download and weekly schedule. The schedules were then modified according to the new figures via links in the spreadsheet. For each scenario, the offset and inventory results were recorded and analysed. This is shown below. In order to show the processes that would be followed when dealing when faced with 'What If?' scenarios. Scenario 1, maximum forecast, was designed to simulate a real capacity problem. It was worked through with changes being made to the

EXPERIMENTATION AND RESULTS

schedules by means of changing run frequencies and schedule running orders to get the most efficient result that works in the time available in a normal week (with no bank holidays). It has been a long-term goal for the plant to produce 500 000 cars per year and this scenario almost simulates that. Scenario 2 uses a forecast that is closer to current running conditions. There are still capacity issues with this because using current shift patterns that are fully loaded with current volumes would be impossible. This scenario would highlight the number of extra shifts required and highlight the resultant staff shortages this would bring and the potential for overtime. Scenario 3 is lower than current volumes and so should prove easy to achieve capacity objectives. The problems with this scenario lie in the time that inventory would be increased. The blanking machines will be running far fewer parts and so some parts may stay on the floor longer due to shorter batch times and a greater number of dead shifts in the schedule before parts are pressed.

Scenario	MM Volume	HS volume	ED volume	HM (for Spain)	Total volume
1	Current (200K per yr)	Maximum forecast (120K per yr)	Maximum forecast (140K per yr)	28800	488800
2	Current (200K per yr)	Midpoint between current and Max (103680 per yr)	Midpoint between current and Max (100800 per yr)	28800	433280
3	Current (200K per yr)	20 % lower than current (70000 per yr)	20 % lower than current (49000 per yr)	28800	347800

Table 5-2 What If Scenarios

5.4.1 Scenario 1

On the first run through of the model the biggest concern was that all of the schedules over ran, which can clearly be seen in Table 5-4 Capacity Table for

EXPERIMENTATION AND RESULTS

Scenario 1. Also the offset times were unacceptable on 'Blanking 1' and '3', with most times being between 48 and 72 hours between blanking and press. This can be seen in Figure 5-2. The desired result was 24 hours or less. This excess stock was reflected in the days holding and inventory as they were then both too high, as shown in Table 5-3. The information provided to the user allows them to make a judgement of the suitability of the schedule based on those issues as shown in Table 5-3 and Table 5-4.

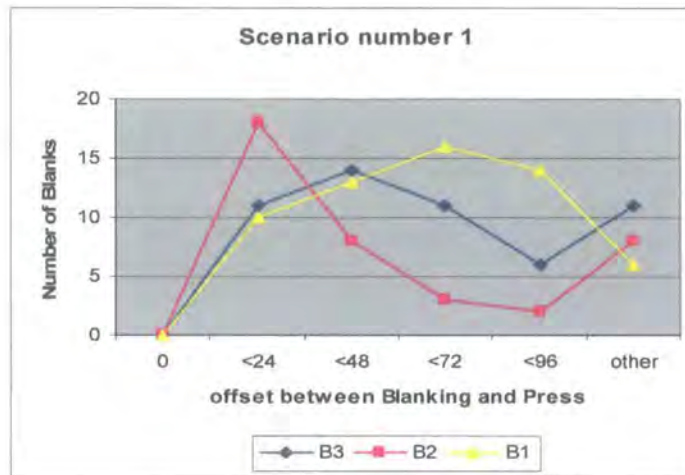

Figure 5-2 Scenario 1 Offsets

Blanking 2 has the lowest stock holding time because the press lines are often waiting for blanks to be produced on it and it overruns so significantly. This can be seen in Table 5-4.

MODEL	INVENTORY							
	BLANK							
	TIME	Witness Result	TARGET	VARIANCE	WitnessDays Holding	TARGET	VARIANCE	JUDGEMENT
MM	1	177800	192104	14304	2.54	2.6	0.06	
	4000	170900		21204	2.44		0.16	ok
	8000	212600		-20496	3.03		-0.43	
HS	1	292700	174507	-118193	4.6	3.32	-1.28	
	4000	329800		-155293	5.19		-1.87	X
	8000	390600		-216093	6.14		-2.82	
ED	1	205300	97561	-107739	3.24	2.66	-0.58	
	4000	212000		-114439	3.34		-0.68	ok
	8000	206800		-109239	3.26		-0.6	

Table 5-3 Inventory table for Scenario 1

EXPERIMENTATION AND RESULTS

It can be seen from Table 5-3 that MM and ED models achieve their targets with regards to days holding, but to the detriment of the HS model. This is the model with most variants and at times the stock is almost double the simulation target. There are more HS parts made on blanking 2 and the laser facilities than the other models. As can be seen from Table 5-4, blanking 2 overruns the most of any of the lines due to the high volume of HS parts it has to blank.

LINE	CAPACITY				
	TOTAL TIME	BUSY AND SET UP TIMES	PLANNED TIME	VARIANCE	JUDGEMENT
BLANK1	7535	5789	4760	-1029	X
				0	
				0	
BLANK2	10324	6545	4478	-2067	X
				0	
				0	
BLANK3	9140	5118	4250	-868	X
				0	
				0	
271	8807	4934	4015	-919	X
				0	
				0	
272	9790	6167	4395	-1772	X
				0	
				0	
273	10019	5498	4355	-1143	X
				0	
				0	
321	8694	7828	6490	-1338	X
				0	
				0	
322	8352	7521	6490	-1031	X
				0	
				0	
5K	8694	7829	6490	-1339	X
				0	
				0	

Table 5-4 Capacity Table for Scenario 1

It can be seen from Table 5-4 that none of the times achieved in this scenario are acceptable. In most cases there is a variance of over -1000 minutes for all of the machines. Even with weekend overtime, the schedules would still be very tight and would not leave any time for trials or machine breakdowns.

EXPERIMENTATION AND RESULTS

5.4.1.1 Reconfiguring the schedule to meet targets

This section shows how the model can be used to optimise the schedules and bring them within acceptable parameters. First the shift patterns were changed, so that all machines work 3 shifts per day starting at 20:45 on Sunday night (time = 0) and finishing at 23:15 on Friday evening (time = 8400). The schedule changes, were made in stages to monitor the model and analyse the results.

Despite increasing the time available, the times still ran over considerably on machines '272', '321' and the '5k' presses. This can be seen in Figure 5-5. A lot of this time was taken up by die change over due to small batch sizes and waiting for blanks

LINE	CAPACITY				JUDGEMENT
	TOTAL TIME	BUSY AND SET UP TIMES	PLANNED TIME	VARIANCE	
BLANK1	6425	5785	6490	705	ok
				0	
				0	
BLANK2	7268	6547	6490	-57	ok
				0	
				0	
BLANK3	5685	5110	6490	1380	ok
				0	
				0	
271	5924	5344	6490	1146	ok
				0	
				0	
272	7715	6950	6490	-460	marg
				0	
				0	
273	7033	6343	6490	147	ok
				0	
				0	
321	9985	8910	6490	-2420	X
				0	
				0	
322	6867	6192	6490	298	ok
				0	
				0	
5K	9132	8690	6490	-2200	X
				0	
				0	

Table 5-5 Revised Capacity Chart for Scenario 1

EXPERIMENTATION AND RESULTS

To summarise, '271' was idle for 315 minutes, this can be compensated for by downtime because the machine still has time at the end of the week available. More importantly '272' ran over by 460 minutes, but was idle for 868 minutes. '273' was idle for 438 minutes, but still had 147 minutes spare. '321' incurred 690 minutes of set up time and the '5k' experienced 630 minutes.

There was still also a problem with the offset between blanking and press. For blanking machines '1' and '3' especially, the majority of stock was spending too long on the shop floor. For 'Blanking 1' only 17% of parts being on the floor for 24 hours or less. For 'Blanking 3' this figure was 20.75% and 'Blanking 2' reached a more acceptable 46.15%.

Further changes were made to increase the batch sizes of parts on the presses where current run sizes took less than 45 minutes. This meant that some run cycles could be eliminated and that die changeover time could be reduced to a standard six minutes. (45 minutes is the time that it takes to set up the dies for a new part, if the run size of the previous part is 45 minutes or longer then the presses will only incur the six-minute changeover).

The output from the model showed that there were parts experiencing blank shortages that required rescheduling. There were two parts on '271', two for '272' and one for '273'. Both shortages on '272' were for Laser parts (76572/3 4M700), so the Laser schedule and 'Blanking 2' schedule (the press line that feeds the Laser facilities) were reorganised to reflect these parts being pulled up the schedule. The model was then re-run to ensure that these changes did not have a detrimental effect on other lines or schedules in later shifts.

'Blanking 3' and '271' were found to have a lot of spare time, so as to avoid increasing the time between blanking and pressing and causing the '271' press to be waiting for blanks, a dead shift where the press does not run was put in. There is still room to put in more dead shifts, to improve offset times further.

EXPERIMENTATION AND RESULTS

Minor changes for the other lines were also made. For example, moving blanking runs by one or two spaces.

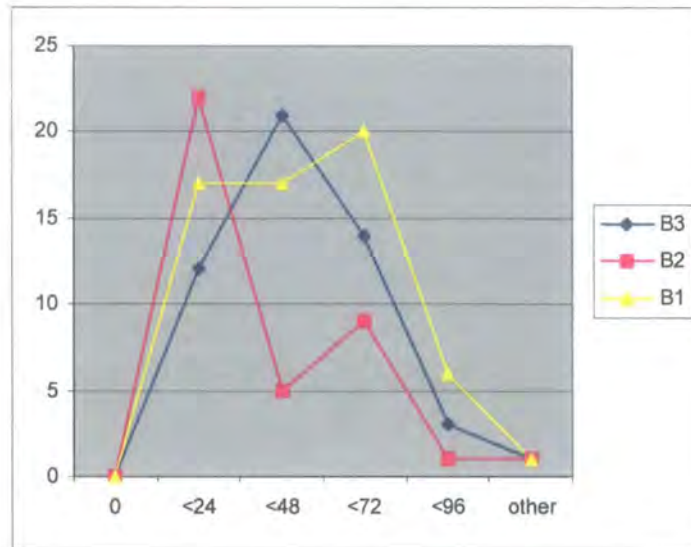

Figure 5-3 Revised Offset charts for Scenario 1

The graph and charts in Figure 5-3 and in Figure 5-4 show that Blanking 2 almost hits the 70% +/- 10% target within 24 hours and that within 48 hours all lines are close to or above the minimum target.

LINE	OFFSET			LINE	OFFSET		
	BLANK	TARGET	JUDGEMENT		BLANK	RESULT	JUDGEMENT
BLK1	70%<24HRS	28%	X	BLK1	70%<48HRS	56%	marg
	+/- 10%				+/- 10%		
BLK2	70%<24HRS	58.00%	marg	BLK2	70%<48HRS	71.00%	ok
	+/- 10%				+/- 10%		
BLK3	70%<24HRS	23.50%	X	BLK3	70%<48HRS	64.70%	ok
	+/- 10%				+/- 10%		

Figure 5-4 Final offset table Scenario 1

There are such big differences between the lines because of the types of parts that run on them. 'Blanking 1' runs left and right hand parts together, whereas the presses may run them on alternate days. The rescheduling of the presses to run in line with the blanking lines is planned for 2004. 'Blanking 2' runs all of the laser parts and so is constrained as to the amount of movement of the schedule. The

EXPERIMENTATION AND RESULTS

parts are run on the laser schedule according to the 'Blanking 2' schedule. This is why it is a lot closer to target than the other two lines. 'Blanking 3' is experiencing problems as the volumes go up because of die constraints on the line. A lot of parts run on the same die which goes in four times per week and those that do not have to fit in around it. Changing this would increase the number of die changes and decrease the time available to run parts.

Table 5-6 shows that it is only HS that is still unacceptably out on days holding.

LINE	CAPACITY				
	TOTAL TIME	BUSY AND SET UP TIMES	PLANNED TIME	VARIANCE	JUDGEMENT
BLANK1	6989	6299	6490	191	ok
				0	
BLANK2	7553	6787	6490	-297	marg
				0	
BLANK3	6212	5587	6490	903	ok
				0	
271	5581	4605	6490	1885	ok
				0	
272	7271	6551	6490	-61	ok
				0	
273	6359	5733	6490	757	ok
				0	
321	8910	7910	6490	-1420	X
				0	
322	7553	6787	6490	-297	marg
				0	
5K	8432	7677	6490	-1187	X
				0	

Table 5-6 Final Capacity chart for Scenario 1

EXPERIMENTATION AND RESULTS

MODEL	INVENTORY							
	BLANK							
	TIME	Witness	GIR target	VARIANCE	Witness holding	GIR target	VARIANCE	JUDGEMENT
MM	1	181639	192104	10465	2.6	2.6	0	
	4000	185908		6196	2.65		-0.05	OK
	8000	222979		-30875	3.19		-0.59	
HS	1	256542	174507	-82035	4.03	3.32	-0.71	
	4000	309488		-134981	4.87		-1.55	X
	8000	310331		-135824	4.88		-1.56	
ED	1	167371	97561	-80929	2.64	2.66	0.02	
	4000	178490		-65666	2.82		-0.16	OK
	8000	163227		-69810	2.57		0.09	

Table 5-7 Final Inventory table for Scenario 1

It can be seen that the biggest problems in terms of capacity are now the 3200 T lines ('321' and '322') and the '5k'.

Even with overtime, the schedule would only be able to recover 455 minutes on each line. This would then lead to the unavoidable, yet disliked, option of outsourcing. Due to Nissan's alliance with Renault this may not be a massive problem as already six panel types are received from Renault's Flin manufacturing site. It would of course mean increasing logistics costs and reduce control of production.

In fact, because it was ED that had experienced the biggest volume increase in this scenario it was suggested that this increase was unrealistic and so ED volume was reduced to 100 000 cars per year from an initial figure of 140 000. The former figure is more realistic as the maximum production for this part as the press shop are only currently manufacturing around 50 000 cars per year in this very competitive sector of the market. The parts that were most adversely affected by the maximum volume of ED being 140000 were the ones running on the 5000T. These are parts such as body sides and fenders, which take a longer time to press.

EXPERIMENTATION AND RESULTS

This is still double the current production level and with the increase of HS too, some common HS and ED parts were rescheduled to run 3 times a week to compensate. The parts affected are A75528 4MGAB and A75512 5M2GB.

MODEL	INVENTORY							
	BLANK							
	TIME	Witness	GIR target	VARIANCE	Witness holding	GIR target	VARIANCE	JUDGEMENT
MM	1	178918	192104	13186	2.56	2.6	0.04	
	4000	158579		33525	2.27		0.33	OK
	8000	184012		8092	2.63		-0.03	
HS	1	252574	174507	-78067	4.59	3.32	-1.27	
	4000	278233		-103726	5.06		-1.74	Marg
	8000	289557		-115050	5.27		-1.95	
ED	1	156753	97561	-59192	3.4	2.66	-0.74	
	4000	146641		-49080	3.21		-0.55	MARG
	8000	1375815		-1278254	3.01		-0.35	

Table 5-8 Inventory table for lower ED volume Scenario 1

LINE	OFFSET		
	BLANK		
	TARGET	RESULT	JUDGEMENT
BLK1	70%<24HRS	32%	X
	+/- 10%		
BLK2	70%<24HRS	50.00%	marg
	+/- 10%		
BLK3	70%<24HRS	25.00%	X
	+/- 10%		

LINE	OFFSET		
	BLANK		
	TARGET	RESULT	JUDGEMENT
BLK1	70%<48HRS	67%	OK
	+/- 10%		
BLK2	70%<48HRS	68.00%	OK
	+/- 10%		
BLK3	70%<48HRS	70.00%	OK
	+/- 10%		

Table 5-9 Offset tables for lower ED volume

EXPERIMENTATION AND RESULTS

LINE	CAPACITY				
	TOTAL TIME	BUSY AND SET UP TIMES	PLANNED TIME	VARIANCE	JUDGEMENT
BLANK1	6474	5834	6490	656	ok
				0	
				0	
BLANK2	6940	6250	6490	240	ok
				0	
				0	
BLANK3	6099	5074	6490	1416	ok
				0	
				0	
271	5966	4941	6490	1549	ok
				0	
				0	
272	6626	5956	6490	534	OK
				0	
				0	
273	5901	5320	6490	1170	ok
				0	
				0	
321	7583	6817	6490	-327	MARG
				0	
				0	
322	6739	6069	6490	421	ok
				0	
				0	
5K	8064	7254	6490	-764	X
				0	
				0	

Table 5-10 Capacity table for lower ED volume Scenario 1

Despite these changes, shown in Table 5-9 and Table 5-10 the '5k' and '321' still ran over. Future work might involve re-balancing the lines. This is easier for the 3200T lines as they can swap parts quite easily, but a lot of parts on the '5k' cannot be shifted because they need the weight of the press to form properly. Another alternative is to run weekend overtime. It may be proven that even with reduced ED volume, this scenario is not viable.



EXPERIMENTATION AND RESULTS

5.4.2 Scenario 2

Scenario 2 had planned volumes of 200K MM, just over 100K ED and 103.5K of HS. In this scenario it was necessary just to do the initial run through to get an idea of the time taken to run the proposed volumes and mix. It can be seen from the resulting inventory table in that MM is within its targets – mainly because the volume is the same as current. HS and ED are experiencing higher volumes than current, so using current schedules are over target.

MODEL	INVENTORY							
	BLANK							
	TIME	Witness	GIR Target	VARIANCE	Witness Holding	GIR Target	VARIANCE	JUDGEMENT
MM	1	179300	192104	12804	2.56	2.6	0.04	
	4000	198000		-5896	2.83		-0.23	OK
	8000	226300		-34196	3.23		-0.63	
HS	1	197100	174507	-22593	3.58	3.32	-0.26	
	4000	228100		-53593	4.15		-0.83	X
	8000	289100		-114593	5.26		-1.94	
ED	1	148400	97561	-50839	3.25	2.66	-0.59	
	4000	141200		-43639	3.09		-0.43	MARG
	8000	149000		-51439	3.26		-0.6	

LINE	OFFSET		
	BLANK		
	TARGET	RESULT	JUDGEMENT
BLK1	70%<24-HRS	19%	X
	+/- 10%		
BLK2	70%<24-HRS	48.70%	MARG
	+/- 10%		
BLK3	70%<24-HRS	19.20%	X
	+/- 10%		

Table 5-11 Inventory and Offset table for Scenario 2

EXPERIMENTATION AND RESULTS

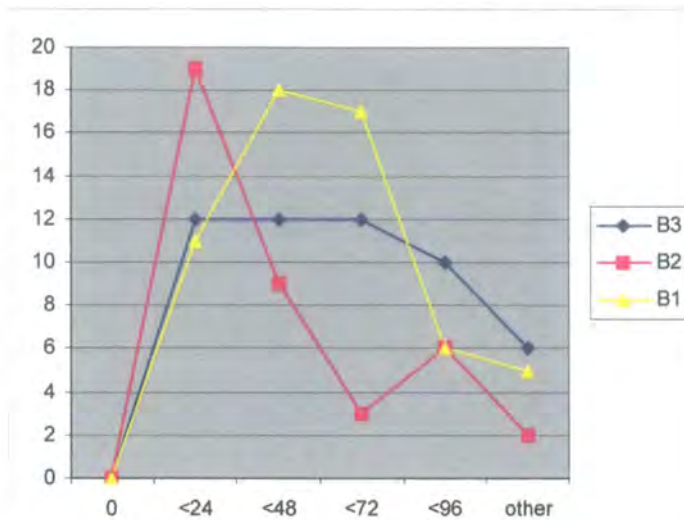

Figure 5-5 Offset chart for Scenario 2

LINE	CAPACITY				JUDGEMENT
	TOTAL TIME	BUSY AND SET UP TIMES	PLANNED TIME	VARIANCE	
BLANK1	7132	5432	4760	-672	marg
				0	
				0	
BLANK2	9790	6010	4478	-1532	X
				0	
				0	
BLANK3	8967	4937	4250	-687	marg
				0	
				0	
271	11670	6240	4015	-2225	X
				0	
				0	
272	9735	6120	4395	-1725	X
				0	
				0	
273	10080	5519	4355	-1164	X
				0	
				0	
321	8350	7520	6490	-1030	X
				0	
				0	
322	7874	7093	6490	-603	marg
				0	
				0	
5K	8357	7527	6490	-1037	X
				0	
				0	

Table 5-12 Capacity table for Scenario 2

EXPERIMENTATION AND RESULTS

The offset table and chart shows that 'blinking 2' is closest to target. In this scenario, the 'blinking 2' line is mainly producing body sides with 2 or 3 cycles and laser parts. This means that the laser schedule is synchronised with the blinking schedule and so the time a blank spends on the floor is not affected too much – refer to Figure 5-5. The capacity of the lines is more worrying but not impossible to fix. The lines are running to the running pattern in APPENDIX D so taking out the dead shifts would mean that the blinking lines and the 2700 press lines would be moved closer to target. There was a lot of waiting time on the '27001' and '27002' and '32001', adjusting the press lines to suit, as in scenario 1, eliminated this problem. For '32002' and the '5000T' presses, measures like working through breaks and weekends would need to be considered.

5.4.3 Scenario 3

In this scenario the following volumes were observed; current MM of 200K, and 20% lower than current volumes of ED and HS, which is 49K and 70K respectively. With a 48-week production year, this equates to 833 MM, 204 ED and 291 HS being consumed per day by the body shop (during early and late shift)

The model was run through with these figures and the current shift patterns as shown in APPENDIX D.

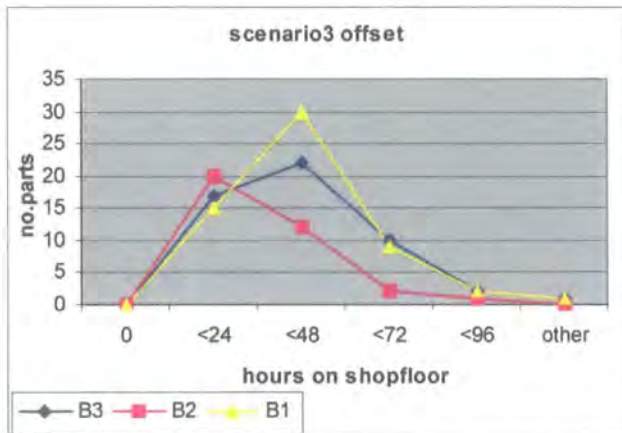

LINE	OFFSET		
	TARGET	RESULT	JUDGEMENT
BLK1	70%<24HRS	26%	X
	+/- 10%		
BLK2	70%<24HRS	57.00%	marg
	+/- 10%		
BLK3	70%<24HRS	33.00%	X
	+/- 10%		

LINE	OFFSET		
	TARGET	RESULT	JUDGEMENT
BLK1	70%<48HRS	79%	ok
	+/- 10%		
BLK2	70%<48HRS	94.00%	ok
	+/- 10%		
BLK3	70%<48HRS	75.00%	ok
	+/- 10%		

Figure 5-6 Scenario 3 Offsets

The charts in Figure 5-6 show that although the target for the offsets does not meet the targets for less than 24 hours on the shop floor between blanking and press, they are met comfortably when the target is two days. This proves that the schedules are not far off the one-day target and with some restructuring, the majority of parts should come into line.

EXPERIMENTATION AND RESULTS

LINE	OFFSET		
	BLANK		
	TARGET	RESULT	JUDGEMENT
BLK1	70%<24HRS	59%	marg
	+/- 10%		
BLK2	70%<24HRS	66.00%	ok
	+/- 10%		
BLK3	70%<24HRS	51.00%	marg
	+/- 10%		

Table 5-13 Comparison to wk 28 offsets

Comparing Table 5-13 with Figure 5-6 shows the effect of the 20% reduction that the HS and ED models make. Because the production runs are shorter, blanking runs take up less time or may be pulled across dead shifts and so are waiting about longer before they are used by the presses. Altering the dead shifts will compensate for this.

MODEL	INVENTORY							
	BLANK							
	TIME	Witness	GIR Target	VARIANCE	Witness no. days	GIR Target	VARIANCE	JUDGEMENT
MM	1	179080	192104	13024	2.56	2.6	0.04	ok
	4000	174470		17634	2.5		0.1	
	8000	192680		-576	2.75		-0.15	
HS	1	176650	174507	-2143	4.77	3.32	-1.45	
	4000	204580		-30073	5.52		-2.2	X
	8000	209920		-35413	5.67		-2.35	
ED	1	78280	97561	19281	3.53	2.66	-0.87	marg
	4000	83760		13801	3.78		-1.12	
	8000	85530		12031	3.86		-1.2	

Table 5-14 Inventory analysis for Scenario 3

Table 5-14 inventory analysis, shows that the model predicts that HS and ED will be close to the September 2003 GIR targets. MM achieves its target because there is little change from the current volume and ED is also quite comfortable. It can be seen that HS is very close to target at the beginning of the schedule, but this drifts significantly as the schedule progresses. This change in HS inventory may be due to the fact that a lot of HS parts are lasered blanks. Because the laser pallets work in SNPs (Standard number of Parts) of up to 800 parts, a 20% decrease would not

EXPERIMENTATION AND RESULTS

have affected the number of SNPs required to meet production demands. These effects need to be investigated further.

LINE	CAPACITY				JUDGEMENT
	TOTAL TIME	BUSY AND	PLANNED TIME	VARIANCE	
BLANK1	5843	4653	4760	107	ok
				0	
				0	
BLANK2	8080	5341	4478	-863	marg
				0	
				0	
BLANK3	7516	4232	4250	18	ok
				0	
				0	
271	7489	4190	4015	-175	marg
				0	
				0	
272	8042	5012	4395	-617	marg
				0	
				0	
273	8252	4382	4355	-27	ok
				0	
				0	
321	6806	6131	6490	359	ok
				0	
				0	
322	7123	6403	6490	87	ok
				0	
				0	
5K	7194	6474	6490	16	ok
				0	
				0	

Table 5-15 Capacity chart for Scenario 3

Table 5-15 shows that most of the lines are within their targets. Blanking 2 is out by 863 minutes. Again this could be explained by the SNPs of the pallets for laser as this is the line that supplies the two laser facilities. Both of the 2700 press lines incurred downtime due to waiting for parts. 271 was idle for 170 minutes and 272 was idle for 434 minutes. The generic schedule also assumes that all parts run every week, which in reality may not be true as some parts run once per fortnight.

EXPERIMENTATION AND RESULTS

This would reduce the set up times on the presses and so proves how schedules fit into the allotted shifts at present despite being 20% higher.

5.5 Implementation and Expected Benefits

Several experiments, representing real-life scenarios, were carried out on the model. To perform similar experiments in a spreadsheet may have taken 2–3 days whereas the simulation model is quick to run and analyse; taking only half a day. This means it brings quick and accurate results and allows the user also to do more detailed analysis and schedule testing. Over a year, if an average hourly labour rate of £25 is assumed, and that it is necessary to perform 'What if?' scenario experiments once a month, the savings would amount to £6000 per annum. This is based on the Witness model taking 4 hours to prepare, run and analyse compared with the 3 days it would take on a spreadsheet.

Implementation is expected after a training period where real schedules and scenarios will be tested to improve the user's ability and confidence in the results. The results and conclusions can then be distributed to the shop floor and production control users for feedback and implementation.

This implementation should also bring about indirect benefits of simulation such as preventing unrealistic schedules from being administered to the shop floor. These schedules could cause idle machine time if presses are waiting for blanks that haven't been made or possible body shop stoppages waiting for panels. They would also reduce confidence that shop floor staff have in production control's scheduling abilities.

Another benefit is that of a potential to increase employee improvement suggestions coming to fruition. This is because it would be quicker and easier for the idea to be tested and for the savings results to be fed back in both inventory quantity and monetary values.

6 Future Work and Conclusions

6.1 Achievement of Major Goals and Objectives

The original aim of this research was to produce a fully functioning, easy to use Discrete Event Simulation (DES) model of a high volume press shop and deploy it using the principles of Digital Enterprise Technology (DET) to improve efficiency and scheduling. The model shall be used to predict the outcomes of various 'What If?' scenarios imposed by the user and have been verified and validated.

To achieve this aim, a working simulation of a high volume Press Shop has been produced that can produce results concerning capacity, inventory and offsets for 'What If?' scenarios. To support the model, a DET implementation has been revised as shown in Figure 3-1 to maintain links between systems, the model and the feedback of the results to the user.

The main objective of the research was to show the advantages of using a Discrete Event Simulation software package to create a model of the press shop. This involved assessing and selecting the software package most suitable for the simulation, creating and using a simulation model for capacity planning and flow optimisation, performing "What If?" scenarios and validating the model using real data.

All parts of the objective have been successfully carried out and have resulted in benefits for the press shop, the company as a whole and the wider awareness and appreciation of DES techniques. The rest of this chapter describes how this has come about in greater detail.

6.1.1 Model of the Press Shop

A press shop model has been created which can be used to optimise schedules, increase knowledge management of constraints and provide data updates and

FUTURE WORK AND CONCLUSIONS

allow "What If?" scenarios of planned stoppage times and trials or machine breakdowns. The model was shown to be a true reflection of the real system by comparing the actual end of month's stocks and the results of the model taken at the same time.

The model has assisted in the reduction of blank stocks on the floor and in the monitoring of the time between blanking and pressing. The results were dramatic, with the cost of holding inventory being reduced from £639,315 at the start of 2003, to £444,917 at the end of August 2003. This is on target for the end of year figure of £432,332. The number of days holding has been reduced from 4.07 at the start of 2003 to 2.83 at the end of August. The system will be used to ensure that the end of year target, of 2.6 days is met.

The use of the model in the press shop has also significantly reduced the time necessary to run "What-If?" scenarios from 3 days using spreadsheets to 3 hours using Witness. If the model were used twelve times a year and the average wage cost were £25 per hour including overheads, then the saving per year in time alone would be £6300. This saving will be continued over the coming years and may increase if the scope of the model was extended.

The use of the model for what if scenarios proved the value of the models continued use in the press shop. Using the model to analyse the effects of volume changes and re run it when schedules had been revised proved invaluable but difficult to accurately quantify. The model results provide support for changing shift patterns and schedules and can be compared against other strategies for deciding the best running patterns and capacity of the shop.

6.1.2 Increased Communication

In terms of DET, there is marked improvement in the feedback of results via set out channels and common methods, using graphs and charts decided early on in the project. This is particularly important during new product and process development and the confirmation of times and schedules. The results of a press shop model

FUTURE WORK AND CONCLUSIONS

are used to optimise schedules, increase knowledge management of constraints and provide data updates and allow "What If?" scenarios of planned stoppage times and trials or machine breakdowns.

6.1.3 Awareness of DES / DET

The benchmarking undertaken, identified Witness as the best Discrete Event Simulation software package to use for the project by meeting all of the most important criteria. As has been highlighted throughout this research, getting acceptance is the hardest thing about introducing simulation models into a company. By introducing DES and DET into NMUK, it is hoped that the experience and improvements made as a result of the model will put confidence in DES. This can then be passed on to other users in order to get continued benefit from this and future projects.

It is thought that many of the barriers to simulation described by Perera (2001) in Figure 2-7 have been overcome. Areas identified as achieved are application oriented research, increased awareness and exposure of DES and DET in the press shop and throughout the company and a increase in internal capability through training. This internal capability is set to improve further as more users become proficient in using the model and its results.

6.2 How the model and Witness fit in with NMUK systems

It is proposed that the Witness model will be used approximately once per month to assess any operational issues in the press shop or the need for capacity planning for future scenarios and new models.

The system interfaces well with NMUK's MRP system, the downloaded schedules can be fed directly into the model after being saved as text files. Obviously, the model must also be supported and maintained by NMUK to keep it up to date with changes in equipment and parts. The only part of the Witness model that will need updating will be the part types (HS, ED etc) in the count function. This is where the model alerts the user that there are too many or too few parts in a buffer. Outside of the model, the volume function in the generic schedule will need updating so

FUTURE WORK AND CONCLUSIONS

that the new model part type variances (Sunroof, 3/5 DR) are updated when volumes and mixes change. There are so few changes required because of the use of attributes coded into the model. Each part number is an attribute of the part, "panel". This means that the part numbers are never actually listed under model parts but can be called in from schedules by their attribute name.

6.3 Limitations of the Simulation

This research has proven that a DES system can be used as an accurate tool to predict the effect of schedule changes, but it should be remembered that while it has been made as close to reality as possible, there are instances where expert interpretation of the results is required. For example, in the model the dead shifts are defined as very definite slots, whereas in reality shifts may be allowed to run into dead time by half an hour or so to finish production runs.

Because of the requirement to run the model quickly, several assumptions and tradeoffs were made. For example, reducing the number of parts in the model by a factor of 100. Before this was done, the model took up to 45 minutes to run and it was difficult and time consuming to make small changes and see their effects with any speed. Doing this meant however that some accuracy was lost in the model as to inventory and run sizes. It was necessary to round all of the blanking runs up to meet the press lines demand. This could have adversely added to the cost of inventory, number of days holding and the length of time the lines took to finish their schedules. The effect of this was found to be negligible, but it would be sensible to put monitoring procedures in place to periodically verify the accuracy of the model.

The simulation is also limited by the fact that it has been used for a brown field site. If it were a green field site the scope of the project could be greatly increased. Elements such as routes that parts take could be made more efficient and the storage and movement of materials, dies and inventory could be improved.

FUTURE WORK AND CONCLUSIONS

Although the model in this thesis is only used in a high volume press shop, in reality it could be used for lots of flow or batch applications as shown in Figure 1-1 where parts take different routes depending on the end item they will be used for. An example within the same plant is the casting shop where molten metal is formed in various moulds. Other, more diverse environments could be in an extrusion plant, which is likely to be batch jobs where material goes through several different processes, or even somewhere like a cheese factory where instead of press machines; cutting and packing machines with different cycle times and capabilities are used and parts are taken from end of line.

6.4 Future Work

It is proposed to investigate scenarios 2 and 3 further, in the same way as was done with Scenario 1. This is to find out more about how changing run cycles and volumes and product mix affects the inventory and capacity of the lines. Analysis such as that done for Scenario 1 will be carried out and the results disseminated.

The model will continue to be used to verify capacity on a monthly basis to analyse capacity plans for both the short and longer term and carry out more "What-If?" scenarios and use the model for dynamic capacity planning as the volume increases for the new Micra vehicle.

There are also proposed new models for the plant from the end of 2004. The model will then be used for the phasing out of the current models and trials and phasing in of the new model.

An assumption made in the model was that of the constant availability of labour. This issue has become more prevalent since the start of the project in January 2002. Since then the number of staff available to run the lines has been reduced and so created the need for dead shifts on the lines. When carrying out capacity planning for the future, it will be important to calculate the number of shifts required

FUTURE WORK AND CONCLUSIONS

per week on each line and hence the number of men to work them. The model could then be used to support proposals for the allocation of extra labour.

Up to now, the model has concentrated mainly on the blanking inventory reduction. At present the Body shop consumer unit (after the press lines) is not accurate enough to perform inventory analysis because parts are only removed from the buffers in one batch once per day. This was necessary to the quantities of parts required per hour for the smaller variants. Sometimes this would only be three or four parts and because the model had had the batches reduced by a factor of 100; it would not be viable to remove the equivalent of 100 parts per hour. In the future it is proposed that a better body shop facility function is created in the model so that inventory and other factors such as stillages can be investigated.

To make the model more accessible and central to the weekly scheduling process, it is a good idea to have a more user-friendly interface on the front end. This will mean that users not trained in Witness can still put data into the model and analyse the results that come out. The most frequent users of the system are likely to be members of production control in the Press Shop as these are responsible for the scheduling of the lines. In the short term, a training plan will be drawn up and executed so that people get the most out of the model.

6.5 Closing Remarks

In overall conclusion this project has been successful in the support of inventory and cost reduction in the press shop and there is a lot of scope for its continued use in the future for further line balancing and long term scheduling. As the research has progressed, confidence has grown in the results produced and there is support to use the model for capacity planning for new models in the future.

The model will have much further reaching applications than just the press shop. The methodology and techniques used in this research can be used for future projects as an example of a proven good working practice. The practices and

FUTURE WORK AND CONCLUSIONS

methodology from this work are also applicable in any other areas of the manufacturing sector as techniques of good practice.

Carrying out the training of more users in the use of the model and the analysis of the results, will undoubtedly lead to increased use and perhaps the creation of more models, to tackle problems in other areas of the Press Shop and the company. This will mean that simulation will become an integral part of scheduling at NMUK.

References

Adesola, B.A., Roy, R., Thornton, S., 2002. A knowledge model for managing schedule disturbance in steelmaking. *In: P.G. Maropoulos, ed. Proceedings of the 1st International CIRP Seminar on Digital Enterprise Technology, 16-17 September 2002, Durham.* Durham University, 147-154.

Al-Aomar, Raid, 2000. Product mix analysis with DES. *In: J.A. Joines, R.R. Barton, eds. Proceedings of the 2000 Winter Simulation Conference, 10-13 December 2000, Orlando, Florida, USA.* 1385–1392.

Alexander, Joseph, Chandrasekharan M.P., 1991. A competitive Analysis of Clustering Methods for Part Family Formation in Group Technology. *IE Journal*, 71, 85-89

Alting, L., Hauschild, M., Wenzel, H., 1998. Elements in a new Sustainable Industrial Culture – Environmental assessment in product development. *Robotics and Computer – Integrated Manufacturing*, 14, 429-439.

Antony, Dr Jiju, Coronado, Ricardo Banuelas, 2002. Design for Six Sigma. *Manufacturing Engineer*, 81 (1), 24-26.

Artiba, A., Elmoghraby, S. E., 1997. *The Planning and Scheduling of Production Systems, Methodologies and Applications*, Chapman and Hall.

Askin, Ronald G., Standridge, Charles R., 1993. *Modeling and Analysis of Manufacturing Systems*, John Wiley and Sons Publishing, USA

Banks, Jerry, 2000. Introduction to Simulation. *In: J.A. Joines, R.R. Barton, eds. Proceedings of the 2000 Winter Simulation Conference, 10-13 December 2000, Orlando, Florida, USA.* 9-16

REFERENCES

- Boesal, Justin, Bowder Jr, Royce O., Glover, Fred, Kelly, James P., Westwig, Erik, 2001. Future of simulation optimisation. *In: B.A. Peters, J. Smith, eds. Proceedings of the 2001 Winter Simulation Conference, 9-12 December 2001, Arlington, Virginia, USA.* 1466-1469
- Bramall, D. G., McKay, K. R., Maropoulos, P. G., 2002. Manufacturability Assessment of Early Product Designs. *Proceedings of the 1st International CIRP Seminar on Digital Enterprise Technology Durham, UK.* 16-17 September 2002, Durham University. 141-144.
- Bren, Karin, Grimshaw, David, Myers, Andrew, 2000. Exploiting Knowledge. *Manufacturing Engineer*, 79 (4), August 2000
- Brown, Robert G, 2000. Driving Digital Manufacturing to Reality. *In: J.A. Joines, R.R. Barton, eds. Proceedings of the 2000 Winter Simulation Conference, 10-13 December 2000, Orlando, Florida, USA.* 224-228
- Centeno, Carrillo, 2001. Challenges of Introducing Simulation as a Decision Making Tool. *In: B.A. Peters, J. Smith, eds. Proceedings of the 2001 Winter Simulation Conference, 9-12 December 2001, Arlington, Virginia, USA.* 17-21
- Chen, Li, Simon, L, 1998. A computerized team approach for concurrent product and process design optimisation. *CAD* , 34, 57-69.
- Cheung, W.M., Aziz, H., Maropoulos, P.G., Gao, J. 2002. Integration of a Manufacturing model with state-of-the-art PDM system. *In: P.G. Maropoulos, ed. Proceedings of the 1st International CIRP Seminar on Digital Enterprise Technology, 16-17 September 2002, Durham, UK.* Durham University, 69 – 72
- Chwif, Leonardo, Paul, Ray J., Barretto, Marcos R. P., 2000. On simulation Model Complexity. *In: J.A. Joines, R.R. Barton, eds. Proceedings of the 2000 Winter Simulation Conference, 10-13 December 2000, Orlando, Florida, USA.* 449-455

REFERENCES

- Czarnecki, Hank, Schroer, Bernard J., Rahman, Mizzanur, 1997. "Using Simulation to Schedule Manufacturing Resources", Winter Simulation Conference 1997, p 750 - 757
- Custance, Lucie J., Maropoulos, Paul G., Bramall, David G., 2003. Using Discrete Event Simulation to Increase Competitiveness within a High Volume Press Shop, Advances in Manufacturing Technology XVII Proceedings of the ICMR Conference 2003, 9-11 September 2003, Glasgow, Scotland. 449 - 454
- Edwards, Kevin, 2000. Specifying your requirements New Product Introduction. *Manufacturing Engineer*, 79 (4), 174
- Elmaghraby, S.E., Artiba, A., Slomp, J., 1996. *The Planning and Scheduling of Production Systems: Methodologies and applications*. Kluwer Academic Publishers.
- Fan, Dr Ip-Shing, 2000. The Power of PDM. *Manufacturing Engineer*, 79 (6), 244
- Fu, Michael C., 2001. Simulation Optimisation. In: B.A. Peters, J. Smith, eds. *Proceedings of the 2001 Winter Simulation Conference, 9-12 December 2001, Arlington, Virginia, USA*. 53-61
- Golay, M.P., Seong, P.H., Manno, V.P., 1989. A measure of the difficulty of systems diagnosis and its relationship to complexity, *International Journal of General Systems*, 16 (1), 1-23
- Goldsman, David, Tokol, Gamze, 2000. Output analysis procedures for computer simulations. In: J.A. Joines, R.R. Barton, eds. *Proceedings of the 2000 Winter Simulation Conference, 10-13 December 2000, Orlando, Florida, USA*. 39-45

REFERENCES

Hall, John D., Bowden, Royce O., 1998. Simulation Optimization Research and Development. *In: D.J. Madeiros, Edward F. Watson, eds. Proceedings of the 1998 Winter Simulation Conference, 13-16 December 1998, Washington DC, USA.* 1693-1698

Hlupic, Vlatka, 1999. Discrete-Event Simulation Software: What the Users Want. *Simulation...for understanding.* 73 (6), 362 – 370

Holst, Lars, 2001. Integrating Discrete-Event Simulation into the Manufacturing System Development Process: A Methodological Framework. Executive Work Software package Description.

Hon, K.K.B., Zeiner, J. 2002. The Function Model: Basis for guiding the Collaborative Design Process in the early stages *In: P.G. Maropoulos, ed. Proceedings of the 1st International CIRP Seminar on Digital Enterprise Technology, 16-17 September 2002, Durham, UK.* Durham University, 61-64

Howard, L., Lewis, H., 2002. Optimising manufacturing process selection during design. *In: P.G. Maropoulos, ed. Proceedings of the 1st International CIRP Seminar on Digital Enterprise Technology, 16-17 September 2002, Durham, UK.* Durham University, 83 -86

Hu, Anbin, San, Ye, Wang, Zicai, 2001. Verifying and validating Simulation Models. *In: B.A. Peters, J. Smith, eds. Proceedings of the 2001 Winter Simulation Conference, 9-12 December 2001, Arlington, Virginia, USA* 595-599

Ingalls, Ricki G, 2001. Introduction to Simulation. *In: B.A. Peters, J. Smith, eds. Proceedings of the 2001 Winter Simulation Conference, 9-12 December 2001, Arlington, Virginia, USA.* 7-16

REFERENCES

- Kelton, W. David, 2000. Experimental design for simulation. *In: J.A. Joines, R.R. Barton, eds. Proceedings of the 2000 Winter Simulation Conference, 10-13 December 2000, Orlando, Florida, USA. 32-37*
- Kempf, Karl, Uzsay, Reha, Smith, Stephen, Gary, Kevin, 2000. Evaluation and Comparison of Production Schedules. *Computers in Industry 2000, 203-220*
- Knoll, Michael J., Heim, Joseph A., 2000. Ensuring the successful adoption of DES in a manufacturing environment. *In: J.A. Joines, R.R. Barton, eds. Proceedings of the 2000 Winter Simulation Conference, 10-13 December 2000, Orlando, Florida, USA. 1297-1304*
- Lang, Sherman Y.T., Dickinson, John, Buchal, Ralph O., 2002. Cognitive Factors in Distributed Design, *Computers in Industry, 48, 89-98*
- Law, Averill M., 2001. How to build valid and credible Simulation Models. *In: B.A. Peters, J. Smith, eds. Proceedings of the 2001 Winter Simulation Conference, 9-12 December 2001, Arlington, Virginia, USA. 22-29*
- Law, Averill M., McComas, Michael G., 1998. Simulation Based Optimisation, *In: D.J. Madeiros, Edward F. Watson, eds. Proceedings of the 1998 Winter Simulation Conference, 13-16 December 1998, Washington DC, USA, 46-49*
- Law, Averill M., McComas, Michael G., 1998. Simulation of Manufacturing Systems, *In: D.J. Madeiros, Edward F. Watson, eds. Proceedings of the 1998 Winter Simulation Conference, 13-16 December 1998, Washington DC, USA, 49-52*
- Leemis, Lawrence, 2000. Input Modelling. *In: J.A. Joines, R.R. Barton, eds. Proceedings of the 2000 Winter Simulation Conference, 10-13 December 2000, Orlando, Florida, USA. 17-25.*

REFERENCES

Lovett, P.J., Ingram, A., Bancroft, C.N., 1999. A Little Knowledge is a Wondrous thing. *Manufacturing Engineer*, 78 (3), 125-127.

Marinho, J., Ramos, C., 2002. Mixed Interaction to Scalable Intelligent Scheduling. In: P.G. Maropoulos, ed. *Proceedings of the 1st International CIRP Seminar on Digital Enterprise Technology, 16-17 September 2002, Durham, UK*. Durham University. 155-158.

Mehta, Arvind, Rowles, Ian, 1999. Business solutions using Witness. In: P.A. Farrington, H.B. Nemhard, eds. *Proceedings of the 1999 Winter Simulation Conference, 5-8 December 1999, Phoenix, Arizona, USA*, 230-233.

Mirttinen, Pauli, Haemäläinen, Raimo P., 1997. How to benefit from decision analysis in environmental life cycle assessment (LCA). *European Journal of Operational Research*, 102, 279-294

Nikoukaran, Jalal, Paul, Ray J., 1999. Software selection for simulation in manufacturing – a review. *Simulation Practice and Theory* 1999, 1-14

Oh, Youchun, Han, Soon – Hung, Suh, Hyouron, 2001. Mapping Product Structures between CAD and PDM Systems using UML. *Computer Aided Design*, 33, 521-529

Paris, Henri, Brissaud, Daniel, 2000. Model for Process Planning; the links between Process Planning Entities. *Robotics and Computer Integrated Manufacturing*, 16, 259-266

Pidd, Michael, 1996. Five simple principles of modelling, In: J.M. Charnes, D.M. Morrice, eds. *Proceedings of the 1996 Winter Simulation Conference, 8-11 December 1996, Coronado, California, USA*, 721-728

Pidd, Michael, 1998. *Computer Simulation in Management Science*, 2nd ed. Wiley.

REFERENCES

Ritchie – Dunham, James, Morrice, Douglas J., Scott, Judy, Anderson, Edward G, 2000. A Strategic Supply Chain Simulation Model. *In: J.A. Joines, R.R. Barton, eds. Proceedings of the 2000 Winter Simulation Conference, 10-13 December 2000, Orlando, Florida, USA. 1260-1264*

Robinson, S, 1996. *Successful Simulation: A practical approach to Simulation Projects*, McGraw-Hill International UK Ltd.

Sadowski, Deborah A., Grabau, Mark A., 2000. Tips for the successful practice of simulation. *In: J.A. Joines, R.R. Barton, eds. Proceedings of the 2000 Winter Simulation Conference, 10-13 December 2000, Orlando, Florida, USA. 26-31*

Salt, J.D., 1993. Keynote address: simulation should be easy and fun!, *In: Evans, Gerald W., Mollaghasemi, M, eds. Proceedings of the 1993 Winter Simulation Conference, 12-15 December 1993, Los Angeles, California, USA, 1-5*

Sargent, Robert G, 2000. Verification, Validation and Accreditation of Simulation Models. *In: J.A. Joines, R.R. Barton, eds. Proceedings of the 2000 Winter Simulation Conference, 10-13 December 2000, Orlando, Florida, USA. 50-59*

Schriber, Thomas J., Brunner, Daniel T, 2000. Inside DES Software. *In: J.A. Joines, R.R. Barton, eds. Proceedings of the 2000 Winter Simulation Conference, 10-13 December 2000, Orlando, Florida, USA. 90-100*

Seila, Andrew F., 2001. Spreadsheet Simulation. *In: B.A. Peters, J. Smith, eds. Proceedings of the 2001 Winter Simulation Conference, 9-12 December 2001, Arlington, Virginia, USA. 74-79*

Simon, H.A., 1964. The architecture of complexity, *General Systems Yearbook*, 10, 63-76

REFERENCES

- Smith, Jeffrey S., Peters, Brett A., 1996. Short term scheduling using DES. *Southwestern Bell – Technology Resources Inc.* 1996.
- Spicer, Andrew J., Wang, Michael H., Software Tool for End of Life Cycle Consideration within a DSS Approach to Environmental Conscious Design and Manufacturing. *Computers and Engineering*, 29 (1-4), 501-505
- Swisher, James R., Hyden Paul D., Jacobson, Sheldon H., Schruben, Lee W, 2000. A survey of Simulation Optimization Techniques and Procedures. *In: J.A. Joines, R.R. Barton, eds. Proceedings of the 2000 Winter Simulation Conference, 10-13 December 2000, Orlando, Florida, USA.* 119-128
- Van der Zee, Durk-Janke, 2000. Look ahead strategies for controlling both operations in Industry – overview, comparison and exploration. *In: J.A. Joines, R.R. Barton, eds. Proceedings of the 2000 Winter Simulation Conference, 10-13 December 2000, Orlando, Florida, USA.* 1364-1373
- Vliet, van J.W., Lutervelt, van C.A., Karpuschewski, B. 2002. Development and application of a computer guided DFM system. *In: P.G. Maropoulos, ed. Proceedings of the 1st International CIRP Seminar on Digital Enterprise Technology, 16-17 September 2002, Durham, UK.* Durham University, 37-41
- Webster et al., 1984. Determining the level of detail in a simulation model – A case study. *Computers and Industrial Engineering*, 8 (3/4), 215-225
- Wiendahl, H.P., Strtze, H., 1998. Logistic Oriented Product Design. *Journal of Materials Processing Technology*, 76, 12-15
- Williams, Edward J., Gevaert, Andrew, 1997. Pallet optimisation and throughput estimation via simulation. *In: Sigrun Andradottir, Kevin J. Healy, eds. Proceedings of the 1997 Winter Simulation Conference, 10-13 December 2000, Atlanta, Georgia, USA.* 744-749.

REFERENCES

Williams, Mark, 2001. Maximum Cost Reduction, Minimum Effort. *Manufacturing Engineer* , 80 (4), 179-182.

Womack, James P., Jones, Daniel T., Roos, Daniel, 1991. *The machine that changed the world: The story of Lean Production*. Macmillan Publishing

Zhang, F., Xue, D. 2002. Concurrent Design, *Computer Aided Design*, 34 , 27-40.

Zhang, F., Xue, D., 2002. Distributed database and knowledge based modelling for concurrent design, *Computer Aided Design*, 34, 27-40

Websites

www.DFMA.com – Boothroyd and Dewhurst . Design for Manufacture and Assembly

www.smmmt.co.uk – The Society of Motor Manufacturers and Traders Limited

APPENDIX A Witness Model A -1 Witness Model

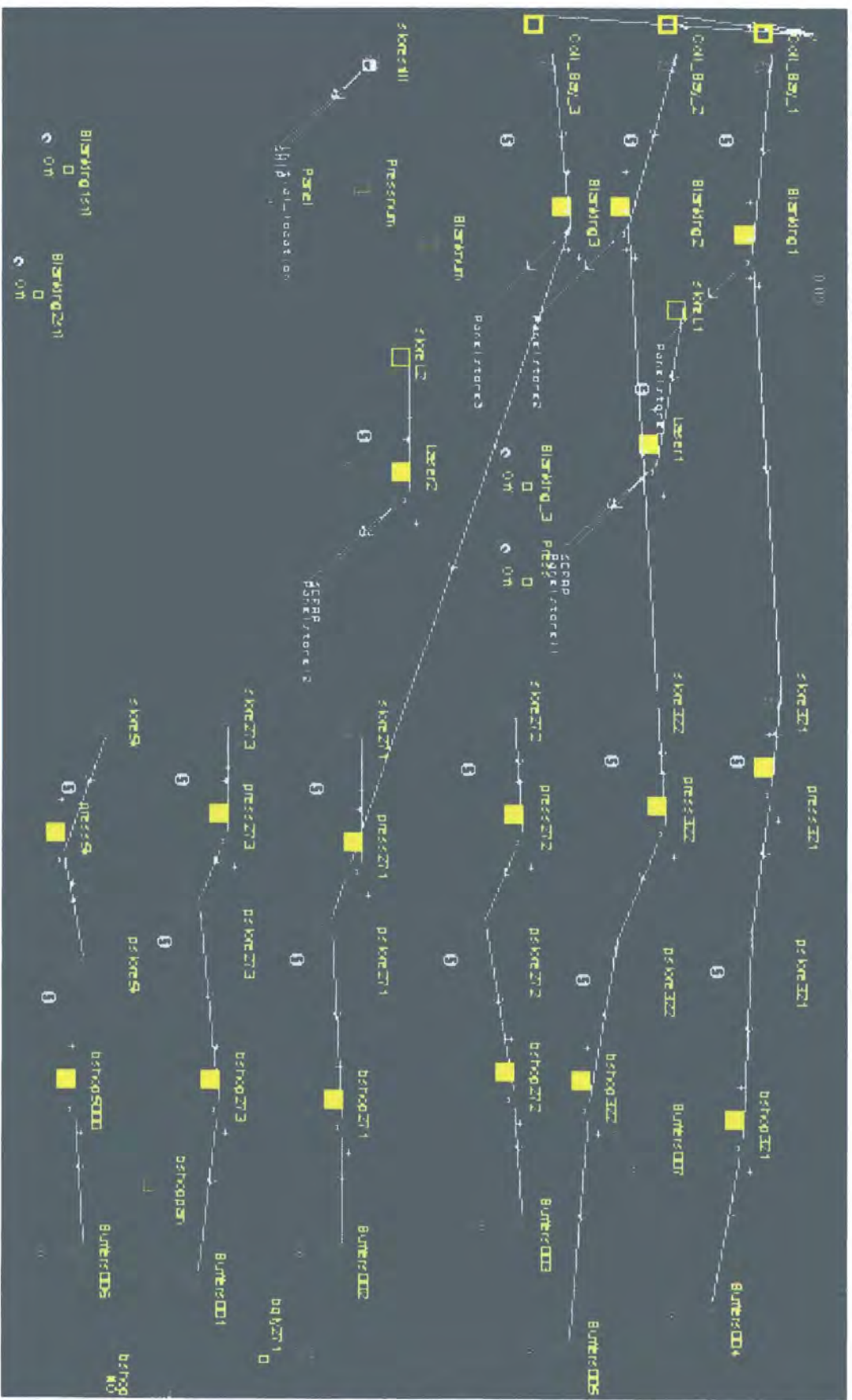

APPENDIX B Software Selection

The following is a detailed description of all the simulation software packages looked at when benchmarking.

B.1 Witness

Witness is already used within Nissan and has several experienced users. This would make back up and support easier to find when problems arise with the simulation. It also means that the simulation would be more readily accepted and trusted than a different software package.

Witness is a lot cheaper than competitors such as Quest and its cost is still coming down. There is the option of having a stand-alone or network software package. The cost for this varies on the number of required users. The training course is offered at a cost of £1850 per person, excluding VAT and accommodation. This may be available at a cheaper rate if bought in conjunction with the Witness software package itself. The Manufacturing based courses are held once a month at the Lanner HQ in Redditch. www.lanner.com

Manufacturer: Lanner

Software package: 2D/3D simulation, programming based

After Sales Support: Comprehensive

Cost: Around £12000 for the hardware to support a stand-alone machine. Various costs for networked machines. Proposed is £156k for 10 licences and training. Much the same for 25 licences excluding training.

Availability: Used extensively within Nissan (2001/2 version) with 10 licences held in industrial engineering since June, Durham University have a licence which will probably soon be updated.

Additional use at Nissan: Plans for other projects in the next 2 years and to add to the number of qualified users. Plans to use it as one would use Excel quickly to validate results.

Special Features: Can link to Excel for both inputs and outputs. Possibility of linking to CAD software package for parts geometry. Has Documentor facility for assigning code in a printable format for each attribute. Makes it easier to view all code at once and use correct titles and links.

For

- Graphics are better than in previous software packages with option of CAD imports
- Easy to track and get statistics about all elements within the simulation : Buffers, Labour, Machines, Conveyors, actual parts
- Can link to other software packages within Microsoft for inputs and outputs.
- Good on line help facility and after sales service, with upgrades. Good levels of training offered.
- Coming down in price
- Already used extensively at Nissan so no integration problems and quick and easy access to back up and support when necessary.
- With links to Microsoft text files, numerous parts and attributes are possible.
- Programming not that difficult to use when performing simple tasks.
- With programming and linking to Excel files, is possible to create schedules
- User forums, discussion groups and conferences regularly held to keep users in touch with one another.
- Received well and recommended by other users

Against

- Graphics not as sound as in other software packages. E.g. Quest
- Programming quite involved for performing advanced tasks.
- Expensive for licences and training

B.2 QUEST

Manufacturer: Delmia

Software package: 3D simulation, Point and Click with SCL and BCL

After Sales Support: Comprehensive

Cost: Full Delmia software package £250K

Quest alone £18K

Availability: Durham University have licence and manuals

Additional use at Nissan: None at present, possibilities for the future.

Special Features: 3D with many camera and alternative views. Easy to track parts, good selection of outputs available. Can link to Excel using Batch Control Language. Good for displaying information to management. Integrated CAD software package

For

- Good user interface
- CAD software package (integrated or otherwise) can be used to model to scale and create a more realistic modelling environment
- Easy to track and get statistics about all elements within the simulation : Buffers, Labour, Machines, Conveyors, actual parts
- Easy to split parts into fractions of production, can have Push or Pull system
- Can link to other software packages, either Delmia or Microsoft for inputs and outputs.
- Good on line help facility and after sales service
- Justifiable possibilities for future use within Nissan

Against

- May be difficult to integrate at Nissan as no similar software package currently in use.
- Is expensive for a licence, maintenance and support and would require a lot of computer memory to run
- Perhaps too elaborate a software package for what is required

- Not really justifiable cost for one project with one trained user.

Others

B.3 Simul8

A 2D point and click software package, which is quite basic in its use. Is simple to use yet only applicable for software packages with few inputs and attributes. Not suitable for complex environments with several "What if?" queries. Graphics are very simple and do not allow links to other programmes/software packages so batch inputs/outputs are not possible.

Not regarded as a software package for complex environments. Output results are not too accurate. www.simul8.com

B.4 Showflow

A 2D/3D software package to model, simulate, animate and analyse processes in logistics, manufacturing and material handling. It is possible to get throughput and lead time information from the results. Only 60 days money back guarantee and free support given after sales. Cheap software at only £275 for everything. www.Showflow.co.uk

Training courses offered, 1 day basic: £250

2 day advanced: £500. Held in Warrington. Not very good for complex problems and solutions.

B.5 CIMstation

Different applications including inspection (Co-ordinate Measuring Machines, CMM) and robotic software packages. From information on web site, it seems that it is not the most appropriate software package. No CIM or CAD data required or available. Used more extensively where it is necessary to convert data from CAD to CIM and vice versa for robotic applications.

B.6 AutoMod

Already used within Nissan Japan and at other automotive companies such as Rover. 3D capabilities and can link up with other software packages. Consultant believes press shop model can be performed although recommended consultancy! Used at BA in small amounts, second to Witness. Has scheduling software package and optimizer. Cost is around £12 000.

B.7 ARENA

2D/3D point and click software package. No heavy programming is required. Arena is quick and easy to use with construction of simple models. More confusing and difficult to keep track of more complex models. Good literature and on line help facility. No UK based help. Cheap to purchase with basic edition costing only £295. Standard edition can handle Kanban and Push/Pull systems. Has an RSS scheduler and Opt Quest optimizer as add ons.

B.8 SIMPROCESS

Training courses only available in America. Uses SIMSCRIPT as language on Network II.5. Not very large software package and does not have much support. Some software packages are no longer supported at all and have no help available. It is quite a unique language. Not much evidence of demos and graphics of actual use of system available on web site. No demo posted.

B.9 ProModel

A Windows based application that has access to external spreadsheets and text files. It has a good Graphical User Interface (GUI) and requires no programming. ProModel has an optimisation tool called Simrunner and can also be used to do schedules and costings. The model has AGV (Advanced Guidance Vehicle) and conveyor capabilities with a downtime application available. On line documentation can be used to assist the user before contacting the vendor.

B.10 GPSS/H

This software package can handle the elements and attributes for people, machines, conveyors and space. It does not use animation and has evolved to be regarded as a programming language.

Figure B-1 Simulation Questionnaire

**Simulation Questionnaire
For software users**

Company : Renault

Nature of company : Automotive

Size of company :

Software package(s) used and Manufacturer : Witness by lanner

Number of users	Trained	250
	Regular	100
Length of use in company		
Cost of software package	Stand alone	
	Network license	
Training given by supplier	Length	
	Location	
	Cost	
After Sales Support	Cost	

Service	Function	Excellent	Good	Average	Poor
After Sales Support	Availability	*			
	Advice Given	*			
	Upgrades patches (Frequency, use)	+	*		

	On line help			*	
	Other...				
Training Given	Standard				
Ease of use	Simple models		*		
	Complex models			*	
How well the software package meets your simulation needs			*		
Integration with other software packages	Microsoft software packages		*		
	CAD software packages				*

Any other comments. Difficulties or good points experienced.

We bought few years ago a software package with the possibility to use 250 licences all over the world. We use only one dongle by place. Each dongle gives between 5 and 20 licences.

As we never use all the licences at the same time, the agreement with Lanner is that we paid only 60 licences and pay the maintenance for theses licences.

We give our own training for the users.

Thank you for your time.

Figure B-6-1 Simulation Questionnaire

**Simulation Questionnaire
For software users**

Company **British Airways PLC**

Nature of company **Scheduled Passenger Airline**

Size of company **50-60k employees worldwide**

Software package(s) used and Manufacturer **Witness (Lanner Group),
Automod (Autologic), Simul8 (Strathclyde Uni)**

		Witness	Automod	Simul8
Number of users	Trained (mostly O.R. employees)	30-40	3	Nothing from BA
	Regular	6	0	0
Length of use in company		10+ yrs	10+ yrs (less prominent)	??
Cost of software package	Stand alone	Software package is free, we run using 20 dongles at a special pro-rate agreed with Lanner	Expensive?	Cheapest?
	Network license		?	?
Training given by supplier	Length	3-5 days	Roughly 1 wk	-
	Location	On site at BA or at Lanner HQ	Their HQ	-
	Cost	5-7k depending on location	?	-
After Sales Support	Cost	Special pro-rate agreed with Lanner	-	-

WITNESS only (no comments on Automod or Simul8 from here on)

Service	Function	Excellent	Good	Average	Poor
----------------	-----------------	------------------	-------------	----------------	-------------

After Sales Support	Availability	X	e-mails replied same day (often within 2 hrs), good phone availability	
	Advice Given	X (to Good)	Quick to understand issue and come up w/solution	
	Upgrades + patches (Frequency, use)		X	Patches available or web or at user conference
	On line help		X	Hints & Tips can be hit & miss (relevance), help in the software is good
	Other...	BA benefits from Lanner visits to our HQ (we are big customer – see deals in place), User conference v.useful		
Training Given	Standard		X	When at BA can be too focussed but when at their HQ can be too general
Ease of use (assumed ease of building)	Simple models		X (to average)	Lot of functionality never used, less prompting than some software packages, less menu functions and it's harder to do routings
	Complex models	X		Wide range of functions, flexibility in elements, in control due to coding and able to build in as much complexity as needed
How well the software package meets your simulation needs			X	Need for some baggage systems modelling filled by Automod (special functionality & critical mass in that business)
Integration with other software packages	Microsoft software packages		X	Excel & Access, have had issues controlling Witness from Excel VBA
	CAD software packages	n/a – never tried		

Any other comments. Difficulties or good points experienced.

Speed – improving in terms of software and also with better coding used

Keep programming knowledge alive as new things (e.g. hints & tips) are always coming up/being solved

Documenting models is hard enough and the ‘Documentor’ add-on/function helps turn comments inside the model code into a useful reference document

APPENDIX C The Digital Enterprise Technology Framework

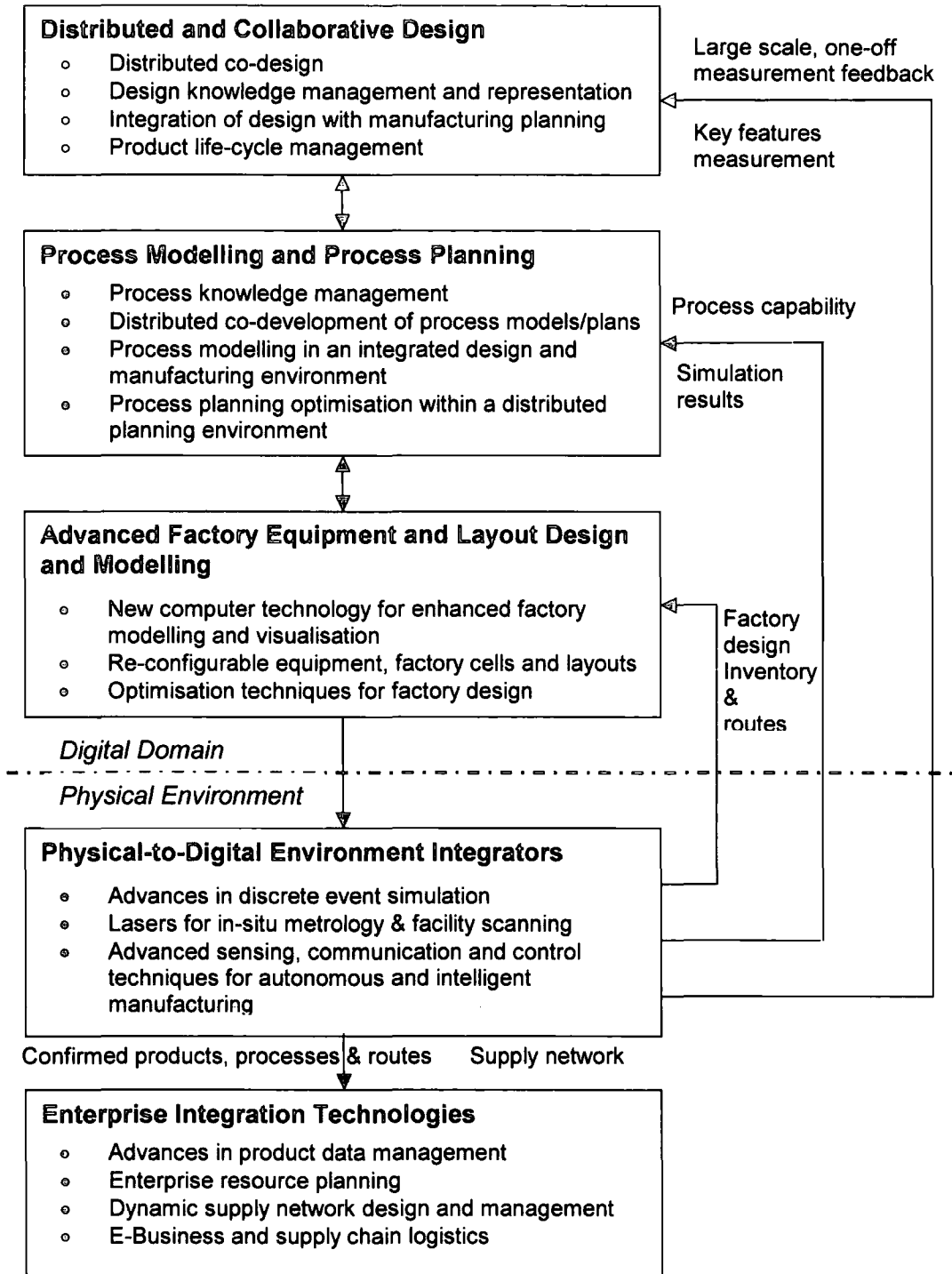

Figure C-1 DET Framework Explained

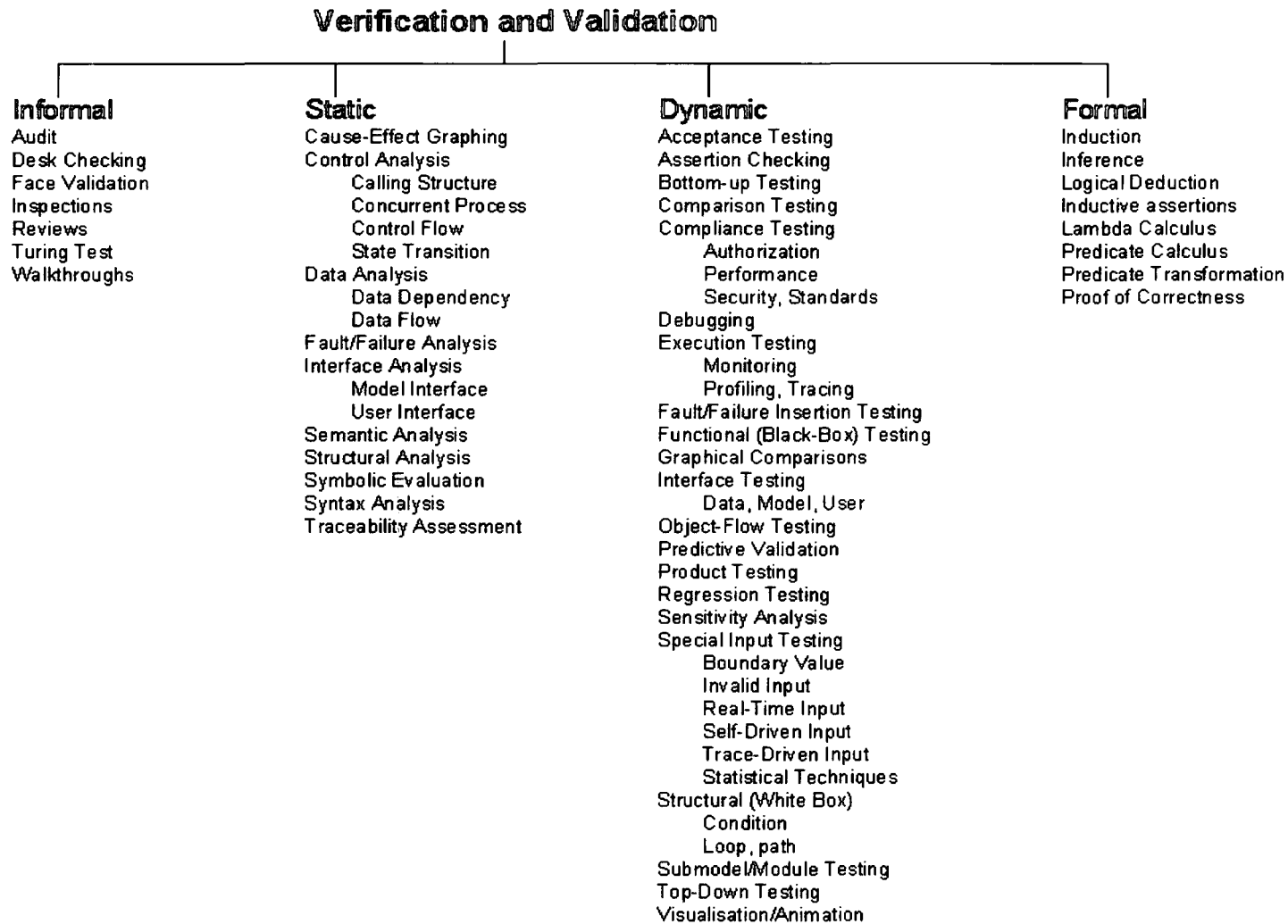

Figure C-2 Verification and Validation Model by Centeno and Carillo 2001)

APPENDIX D

The following is the data collected for the model

- Die change, coil threading and Quality check times. The data was collected from the production database. The database shows the history of all parts run on the blanking and press machines. From this, information such as time taken for quality checks, coil threading and die changes as well as cycle times and whether the machine experienced any other down time can be extracted. A series of 10 –15 results was taken for each machine for each category and continuous distributions set up in Witness

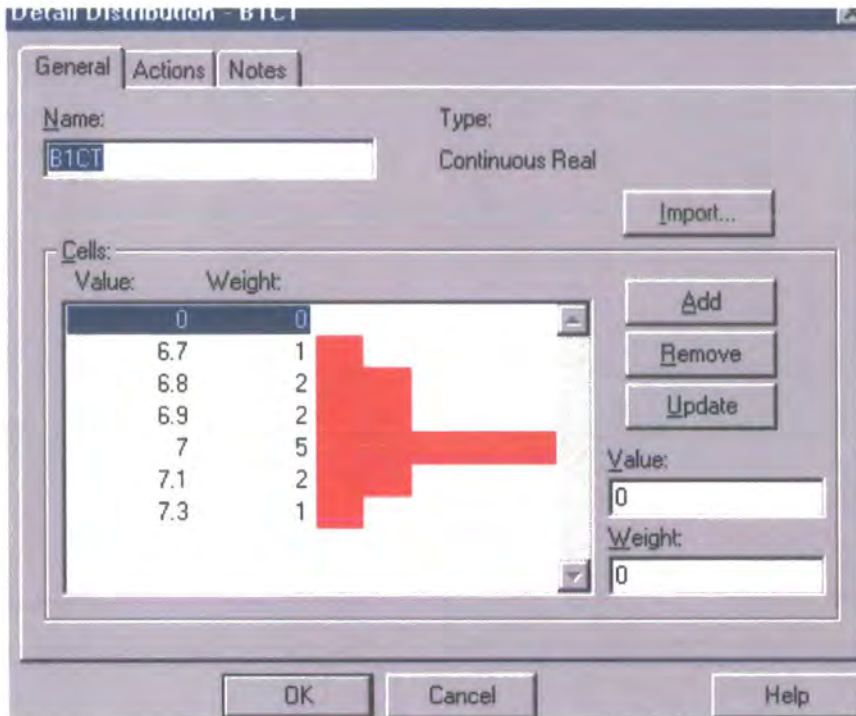

Figure D-1 Blanking 1 Coil Threading Distribution

This is an example of what the distribution looks like in Witness. It is for coil threading (CT) It can then be applied as a variable for the set up times called in the blanking machine. The most common time is around 7 minutes.

The Manual die change distribution is as in Figure D-2

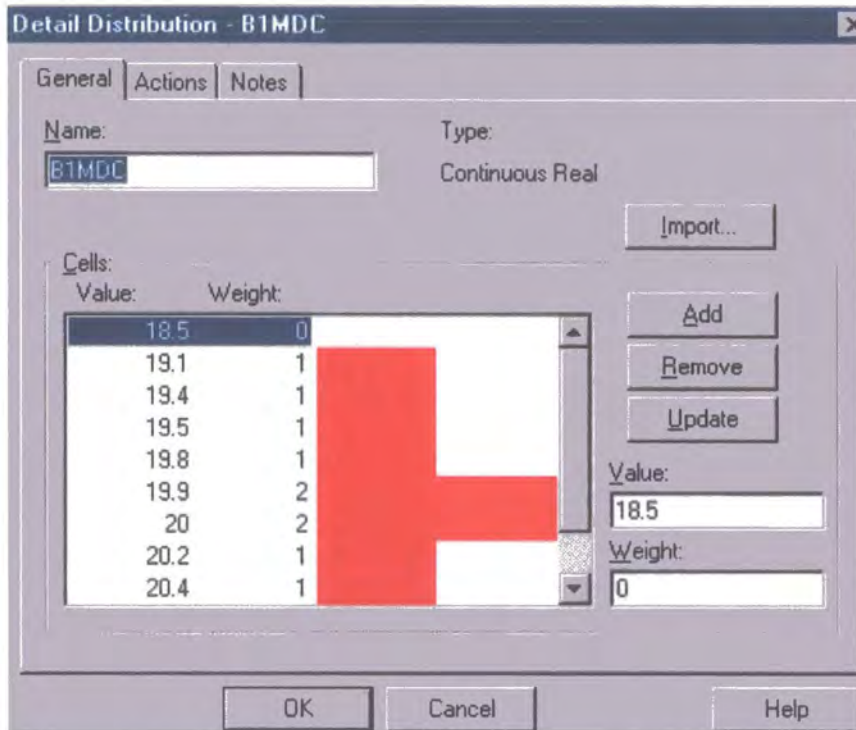
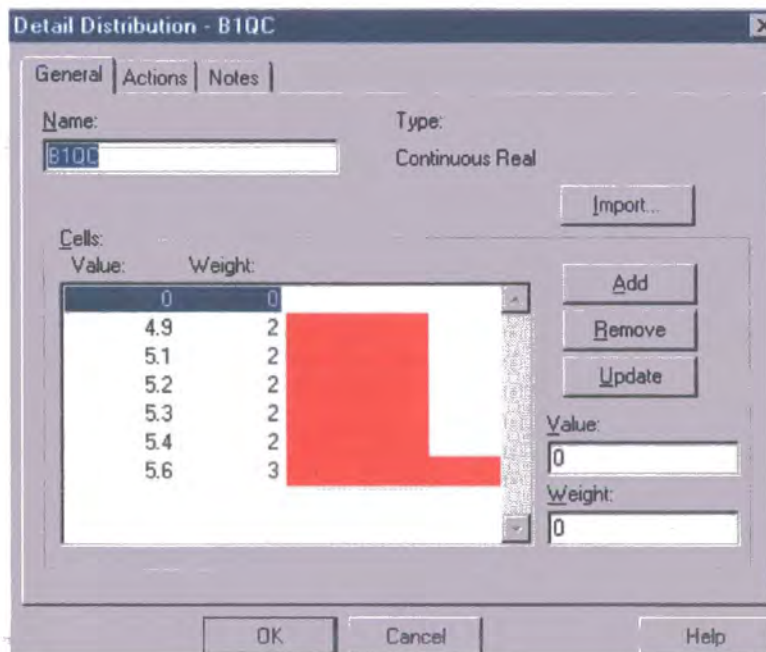

Figure D-2 Blanking 1 Manual Die Change Distribution

It is a distribution around the value of 20 minutes.

Figure D-3 Blanking 1 Quality Check Distribution



The Quality Check information is shown in Figure D-3 and shows a distribution of between 4.9 and 5.6 minutes.

The following data shows the values obtained for Blanking 2 and 3

Table D-1 Blanking 2 Distribution table

Distribution	Data
Die Change	19.7, 19.9, 20, 20, 20, 20.5, 20.5, 20.5, 20.6, 20.7, 21.1, 21.2
Coil Thread	6.6, 6.6, 6.7, 6.7, 6.7, 6.8, 6.8, 6.9, 6.9, 6.9, 6.9, 7, 7
Quality Check	5, 5.3, 5.4, 5.5, 5.5, 5.6, 5.7, 5.8, 5.8, 5.8, 6, 6, 6

Table D-2 Blanking 3 Distribution Table

Distribution	Data
Die Change	12, 12.1, 12.4, 12.5, 12.6, 12.6, 12.6, 12.7, 12.8, 12.8, 12.8, 13.3
Coil Thread	6.1, 6.1, 6.2, 6.3, 6.3, 6.3, 6.4, 6.5, 6.5, 6.5, 6.6, 6.7, 6.7
Quality Check	3.9, 4, 4, 4.1, 4.1, 4.1, 4.1, 4.2, 4.2, 4.3, 4.3, 4.4, 4.4

- Time availability on each line – shift patterns, lunch breaks, down times.

At the beginning of the project most lines were working all shifts. When it came to doing the inventory reduction the shop shift patterns were adhered to. The total time available if all shifts are worked is 6490 minutes. Each shift has a 15 minute break and a 30 minute lunch break.

Blank and Press Running Order															
	SN	MD	ML	MN	TD	TL	TN	WD	WL	WN	THD	THL	THN	FD	FL
BLANK1															
BLANK2															
BLANK3															
LASER1															
LASER2															
27001															
27002															
27003															
32001															
32002															
5000															

Figure D-3 Press Shop Running Orders

- o Total number of parts and number of each part required, batch sizes and weekly volumes.

The number of parts for blanking and press are shown below with their cycle times per part. These times have been multiplied by 10 to make them easier to read. They will be multiplied by 10 again before being used in the model, to compensate for the volumes being reduced by a factor of 100.

Table D-3 Cycle Times

Part	Cycle Time	Part	Cycle Time	Part	Cycle Time
A2315733008	0.74	A75512AV600	1.01	A78112BN800	2.32
A2315733008	0.24	A755135M213	0.81	A781134M6GB	0.55
A631124M615	0.53	A755135M2GB	0.06	A781134M7GB	0.16
A631124M615	0.10	A75513AV600	1.07	A781139M700	2.29
A631124M6GB	0.51	A75513AV600	0.78	A781139M70B	0.39
A631124M6IB	1.70	A755284MGAB	0.38	A78113BN700	1.15
A6311273B05	0.67	A755285M213	0.86	A78113BN800	2.50
A6311273BGB	0.41	A75528AV600	1.15	A791124M7GB	0.29
A63112AV600	0.85	A75528AV600	0.95	A7911250B00	0.70
A63112AV605	0.80	A755294MGAB	0.23	A7911252BNB	0.28
A63112AV60B	0.56	A755295M213	0.88	A79112AU200	0.68
A63112AV6IB	1.65	A75529AV600	0.79	A79112AU20B	0.37
A63112BN700	1.71	A75612AV700	1.08	A79112AV600	0.90
A63112BN700	1.49	A75612AV70B	0.53	A79112AV60B	0.39
A631134M615	2.08	A760223MGLB	1.18	A79112AV700	0.73
A6311373B05	1.07	A760224M602	2.63	A79112AV70B	0.37
A6311373BGB	0.17	A760224M6UB	0.75	A79112BN700	0.73
A63113AV600	0.44	A760224M702	1.52	A8011250BNB	0.51
A63113AV605	0.17	A760224M7GB	0.73	A8011253B00	1.25
A63113AV60B	0.09	A760224M7UB	0.64	A8011253B05	0.99

A63113BN700	1.87
A63113BN700	0.19
A6413250B0B	0.27
A641325M017	0.69
A641325MG1B	0.24
A6413273B00	1.05
A651121F500	1.09
A651124M600	0.90
A651124M605	0.10
A651124M6GB	0.40
A6511250BNB	0.53
A65112AV600	1.22
A65112AV605	1.18
A65112AV60B	0.31
A65112AV6IB	0.44
A65112AV6SB	0.43
A65112BN700	1.22
A651224M605	1.01
A651224M605	0.83
A651224M6GB	0.38
A6512272B05	0.80
A6512272BGB	0.36
A65122AV600	0.90
A65122AV60B	0.40
A6513172B00	0.70
A6513172BSB	0.28
A663121F520	0.91
A6631251BNB	0.27
A663125M1GB	0.29
A663125M317	0.65
A663125M467	0.18

A760224MGAS	3.59
A7602252BNB	0.75
A760225MGAS	3.21
A7602273B00	1.24
A7602276B10	1.67
A7602276BNB	0.74
A76022AU20B	1.02
A76022AU210	2.55
A76022AV600	2.95
A76022AV60B	1.28
A76022AV700	3.13
A76022AV70B	1.18
A760234M602	2.08
A760234M607	0.52
A760234M702	1.23
A760234MGAS	3.65
A760235MGAS	3.17
A7602373B00	1.45
A7602373BNB	0.89
A7602376B10	1.49
A7602376BNB	1.20
A76023AU20B	1.15
A76023AU210	2.17
A76023AV600	2.82
A76023AV60B	1.07
A76023AV700	2.50
A76023AV70B	1.13
A762324M600	0.75
A762324M6RB	0.61
A762324M700	1.06
A762324M7LB	0.39

A8011253BNB	0.38
A801125M320	1.95
A801125M3GB	0.88
A801125M405	1.05
A801125M420	1.04
A801125M4GB	0.77
A8011274B00	0.93
A8011274B05	1.20
A80112AV600	1.74
A80112AV605	1.44
A80112AV6FB	0.60
A80112AV6RB	0.51
A80112AVLAS	7.71
A80112B0B0B	0.41
A80112B3B0B	0.32
A8011350BNB	0.42
A8011353B00	1.25
A8011353B05	0.98
A8011353BNB	0.74
A801135M320	1.18
A801135M3GB	0.17
A801135M420	1.19
A801135M4GB	0.03
A8011374B00	0.96
A8011374B05	1.37
A8014841B00	0.69
A8014841B00	0.30
A801524M3IB	0.67
A8015250B00	0.78
A8015250B0B	0.87
A8015253B00	0.95

A6631273B00	0.83
A66312BN378	0.99
A66312BN960	0.88
A66312BN970	1.10
A671124M417	0.78
A671124MGAB	0.24
A6711250B00	0.76
A6711251BNB	0.29
A6711252B00	0.70
A671125M017	0.64
A67112AV600	0.77
A67112AV60B	0.33
A671225M007	0.67
A671225M307	0.94
A671225MGAB	0.27
A6731250BSB	0.27
A673125M007	6.52
A673125M017	0.27
A673125M107	8.15
A673125M307	1.32
A673125MGAB	0.31
A6731273B00	1.59
A6731273B10	0.59
A6731274B00	3.79
A6731274B10	0.51
A6731275B00	9.50
A67312AU900	0.90
A67312AV700	15.02
A67312BN700	5.06
A673324M402	0.71

A762324M7UB	0.34
A762324MLAS	1.19
A762325MLAS	1.03
A762334M600	1.06
A762334M6RB	0.49
A762334M700	1.21
A762334M7LB	0.32
A762334M7LB	0.29
A762334M7UB	0.47
A762334M7UB	0.33
A762334MLAS	1.24
A762335MLAS	1.22
A762425M007	0.68
A762425MGAB	0.27
A762435M007	0.04
A764525M013	0.81
A764525MG1B	0.36
A764535M013	0.04
A764825M203	0.88
A764825M2GB	0.34
A764B0AV600	0.90
A764B0AV60B	0.44
A765163MGLB	0.44
A765164M605	1.10
A765164M6UB	0.58
A765164MGAS	1.48
A765174M605	1.23
A765174M6UB	0.74
A765174MGAS	1.39
A765323MGAS	3.18

A8015253BNB	0.56
A801525M305	1.17
A801525M315	4.74
A801525M3GB	1.27
A801525M400	0.90
A801525M405	0.65
A801525M4HB	0.92
A801525M4IB	1.13
A80152AV600	0.64
A80152AV6SB	0.77
A8015350B00	0.82
A8015350B0B	0.04
A8015353B00	0.88
A8015353B0B	0.59
A801535M305	0.53
A801535M315	2.65
A801535M3GB	0.14
A801535M400	1.24
A801535M405	0.54
A801535M4HB	0.06
A801535M4IB	0.32
A80153AV600	0.46
A8211253B00	0.88
A8211253B05	0.93
A8211253BNB	0.73
A821125M405	1.14
A821125MGA B	0.94
A821129M70B	0.47
A821129M710	1.36
A82112AV600	0.97

A673324M40B	0.25
A6733250B00	0.69
A6733250B00	0.25
A6733252B00	0.71
A6733252B00	0.30
A673325M002	0.67
A6741250NYB	0.27
A6741273B00	0.75
A7311241B00	0.39
A731124M10B	0.64
A731124M602	2.04
A731124M702	1.39
A7311273B02	1.35
A7311273B0B	0.39
A7311273B12	0.52
A7311273B1B	0.46
A731129M705	1.97
A731129M70B	0.64
A731129M70B	0.44
A73112AU200	1.91
A73112AU20B	0.50
A73112AV600	1.08
A73112AV60B	0.43
A73112AV610	4.60
A73112AV700	1.85
A73112AV70B	0.62
A7431250B00	1.11
A7431250BNB	0.42
A743125M013	1.02
A743125MGAB	0.53

A765323MGLB	0.78
A765324M605	1.68
A765324M6UB	0.79
A765324M705	0.74
A765324M7GB	0.71
A765324M7UB	0.64
A765327MGAS	1.49
A765334M605	0.16
A765334M705	0.76
A765334M7UB	0.29
A765337MGAS	1.62
A765724M700	0.84
A765724M7LB	0.64
A765724M7UB	0.76
A765724MLAS	1.93
A76572AV600	0.85
A76572AV6LB	0.26
A76572AV6UB	0.49
A76572AVLAS	1.56
A765734M700	0.79
A765734M7UB	0.31
A765734MLAS	1.84
A76573AV600	0.88
A76573AV6UB	0.46
A76573AVLAS	1.62
A7663241B0B	0.66
A766324M600	1.44
A766324M60B	0.61
A766324M60B	0.50
A766324M700	0.99

A82112AV605	1.09
A82112AV60B	0.62
A82112AV705	0.62
A82112B3B0B	0.48
A8211353B00	0.96
A8211353B05	1.11
A8211353BNB	0.52
A821135M405	1.13
A821135MGA B	0.15
A821139M70B	0.15
A821139M710	1.33
A82113AV600	0.14
A82113AV700	1.23
A82114AV600	0.96
A82114AV605	0.89
A82114AV60B	0.34
A8215253B10	0.89
A8215253BNB	0.42
A821525M400	0.95
A821525M405	1.04
A821525M4IB	1.53
A821525MGH B	0.66
A821529M700	1.20
A821529M7HB	0.70
A82152AV600	0.82
A82152AV60B	0.52
A82152AV615	2.63
A82152AV6IB	1.60
A82152AV700	1.16
A8215353B10	0.99

A7431274B00	0.94
A74312AV602	1.06
A74312AV60B	0.40
A74312AX600	0.66
A74312B1B0B	0.36
A743225M213	0.95
A743225M2GB	0.45
A743724M40B	0.27
A74372BN800	0.75
A745121F500	1.15
A745121F510	1.39
A745124U113	0.78
A7451250BNB	0.51
A7451251B10	0.60
A745125M213	0.11
A745125M303	0.24
A745125MGAB	0.26
A74512AV700	2.47
A74512BU10B	0.38
A745144U113	3.03
A745145M213	0.58
A745145MGIB	0.31
A74514AV60B	0.29
A74514AV700	1.06
A751124M4GB	0.67
A7511250B1B	0.90
A7511273B00	0.73
A75112AV600	1.60
A75112AV60B	0.97
A75112BN700	0.89

A766324M70B	0.69
A766324M70B	0.58
A7663253B00	0.83
A7663253B00	0.33
A7663273B00	15.58
A7663273B05	0.49
A76632AV700	0.47
A76632AV70B	0.31
A7663341B0B	0.09
A7663353B00	0.82
A7663373B00	13.71
A7663373B05	0.52
A76633AV700	1.20
A767124M715	0.87
A767124MGAB	0.51
A7671250B00	0.54
A7671251BNB	0.23
A7671253B10	1.00
A76712AV600	0.86
A76712AV60B	0.49
A767134M715	0.90
A767134M7GB	0.01
A7671350B00	0.57
A7671351BNB	0.28
A7671353B10	1.04
A76713AV600	0.86
A76713AV60B	0.10
A767521F500	0.74
A7675251BNB	0.34
A767525M013	0.70

A8215353BNB	0.34
A821535M400	0.95
A821535M405	0.33
A821535MGH B	0.17
A821539M700	1.19
A821539M7HB	0.13
A82153AV600	0.55
A82153AV60B	0.21
A82153AV615	0.26
A82153AV700	0.69
A843129M701	1.39
A843129M70B	0.35
A84312AV600	1.14
A84312AV60B	0.36
A843139M701	0.72
A843139M70B	0.37
A843229M700	1.26
A843229M70B	0.47
A84322AV600	1.28
A84322AV60B	0.55
A901221F511	1.28
A901221F521	0.95
A9012254BNB	0.50
A901225M302	1.28
A901225M3GB	0.38
A90122AU200	1.83
A90122AU20B	0.52
A90122AV700	1.37
A90122AV7NB	0.54
A90122BM30B	2.00

A751131F500	0.69
A75113AV600	1.57
A75113BN700	0.02
A7517250B00	0.65
A7517350B09	0.04
A755125M213	0.78
A755125M2GB	0.48
A75512AV600	1.13
A90152AU2HB	0.74
A90152AU2HB	0.56

A767525MGIB	0.39
A767531F500	0.05
A767535M013	0.14
A781124M6GB	0.65
A781124M7GB	0.93
A781129M700	2.30
A781129M70B	1.00
A78112BN700	1.17
A90152AV700	1.75
A90152AV70B	0.78

A90122BU80B	0.62
A9015254B00	0.86
A9015254BNB	0.64
A901525M302	1.70
A901525M312	0.25
A901525M4GB	0.51
A9015273B01	1.47
A90152AU200	2.15
A90152AV70B	0.68

There are a total of 452 blanks and panels

The weekly volumes of parts are important especially for the 'What If?' scenarios because they are used to calculate the initial fill quantities and batch sizes. Current volumes are shown in More Runs - What If Scenarios 5.4.

The maximum batch size for press parts can be assumed to be 3000 before requiring an additional cycle.

- Safety stock levels – 8 and 10 hours, so that a part never stocks out and the body shop can always be supplied. This is worked out from the volumes for each part type. For example taking into account whether the part is a 3D or 5D, MM, HS or ED. The table below shows the categories the parts were split into and what a shifts stock (8 hours) relates to. The figures have been divided by 100 to make them in keeping with the rest of the model volumes.

Table D-4 Minimum volume table

Mix	%Build	Qty	1 shifts stock
ED	100%	1400	3
ED 4/5D	82%	1148	3
ED 4D	20%	280	1
ED 5D	62%	868	2
ED LHD	65%	910	2
ED RHD	35%	490	1

WED	18%	252	1
ED SUN	10%	140	1
HS	100%	1854	4
HS 3D	19%	352	1
HS 4D	27%	501	2
HS 5D	54%	1001	3
HS 3D/5D	73%	1353	3
HS 4D/5D	81%	1502	4
HS SUN	10%	185	1
HS ED		3254	7
HS ED HM		4254	9
HS ED HM LHD		3797	8
HS ED HM RHD		1857	4
HM		1000	2
HS HM		2854	6
HS HM LHD	84%	2397	5
HS HM RHD	16%	457	1
HS LHD	84%	1557	4
HS RHD	16%	297	1
MM	100%	4085	9
MM 3D	52%	2124	5
MM 5D	48%	1961	4
MM LHD	75%	3064	7
MM RHD	25%	1021	3
MM STD	86%	3513	8
MM SUN	14%	572	2

- Parts that need to be lasered, in order to prepare the laser schedule.
The following list overleaf shows the blanks and the laser blank that they create. The parts on Laser 1 require 2 blanks and the part produced on Laser 2 requires 3 blanks to be lasered together.

Laser Blank	Part Number	SNP	Parts that are lasered
HS 5D B/SIDE RH	76022 5MGAS	300	76022 4M7UB
			76022 4M7GB
HS 5D B/SIDE LH	76023 5MGAS	300	76023 4M7UB
			76022 4M7GB
HS 3D FRT PLR RH	76232 4MLAS	750	76232 4M7UB
			76232 4M6RB
HS 3D FRT PLR LH	76233 4MLAS	750	76233 4M7UB
			76233 4M6RB
HS 5D FRT PLR RH	76232 5MLAS	750	76232 4M7UB
			76232 4M7LB
HS 5D FRT PLR LH	76233 5MLAS	750	76233 4M7UB
			76233 4M7LB
HS 3D RNF LOCK RH	76516 4MGAS	800	76516 4M6UB
			76516 3MGLB
HS 3D RNF LOCK LH	76517 4MGAS	800	76517 4M6UB
			76516 3MGLB
HS 3D LOCK PLR R/L	76532 3MGAS	360	76532 4M6UB
			76532 3MGLB
HS 3D B/SIDE LH	76023 4MGAS	300	76022 4M6UB
			76023 3MGLB
HS 3D B/SIDE RH	76022 4MGAS	300	76022 4M6UB
			76022 3MGLB
ED DOORS	80112 AVLAS	225	80112 AV6RB
			80112 AV6FB
HS 5D CTR PLR RH	76532 7MGAS	400	76532 4M7UB
			76532 4M7GB
HS 5D CTR PLR LH	76533 7MGAS	400	76533 4M7UB
			76533 4M7GB
ED BRACE PLR LH	76573 AVLAS	400	76573 AV6UB
			76572 AV6LB
ED BRACE PLR RH	76572 AVLAS	400	76572 AV6UB
			76572 AV6LB
HS 5D BRACE PLR RH	76572 4MLAS	700	76572 4M7UB
			76572 4M7LB
HS 5D BRACE PLR LH	76573 4MLAS	700	76573 4M7UB
			76573 4M7LB
MM FLOOR	74312 AXLAS	200	74312 AX60B
			76452 AX60B
			76452 AX60B

Table D-5 Laser parts

APPENDIX E

The following gives a more detailed breakdown of how the model has grown.

Blank1simple –

One machine (Blanking1) feeding the different press stores in order to get routing control

Route –

A model trying to route 3 different parts arriving at set intervals through one blanking and 3 press machines.

Model uses simple shift patterns

Some trouble with routing through buffers

Difficult and time consuming to update multiple routings

Some set up times, not linked to distributions though

Batch cycle times

W/o route –

Blank and Press machines now have attributes

3 parts in the model are active

Routing taken off as seen as too complicated to use for model with several parts

New method of routing used with If...Then... rule in output from machine. Less complicated but would mean a lot of repeated programming that would slow the model down.

Lucie1 –

Initial Fill file used to pre fill model with parts in stores

All Blanking stores and lines and the 5000T press used

Actual part numbers instead of Part A etc now used

Coil bay contains 10 parts by number

All parts: Coils, Blanks and Panels input into model individually – this is very time consuming to set up and complicated to change attributes.

Blanking1 –

More realistic shift patterns are used. Blanking starting on Thursday, Press on Monday

Cycle times for parts are referenced in attribute files

Problems with model stopping where parts are not referenced correctly

Cycle times are the time for a single cycle multiplied by the batch size – does mean however that the user cannot tell how far through the batch a machine is at any time – only start and finish.

Parts moving from Blanking 1 to 5000T press

Lucie2 –

Variables in model now reference the batch sizes and are used per part on the machine – can now cope with batch sizes better

Moved to 3 Blanking Lines and the 32/1 press line – a simpler press with less associate parts and constraints.

Schedules now read in from external files

Lucie3 –

A simplification of previous model

Average cycle times used

More user friendly with output to screen of batch quantity and time when a new batch is started

Lucie4 –

Distributions of parts used to make set up times for realistic

Lucie5 –

Problems arising with not having parts defined properly in the model

Die sets and Quality check and Coil thread distributions introduced for the Blanking Lines. Use of random numbers instead of getting exactly the same results every time.

Lucie6 –

Model prefills as expected, some problems where parts going in are not defined properly in the model

Parts have fixed attribute values for die sets and cycle times for Blanking and Press. Some problems have arisen in reading these fixed attribute values.

Lucie7 –

Some tweaking but no major differences

Lucie8 and 9 –

Problem with advancing to next part in Blanking 1 schedule. Help desk contacted for support.

Cycle times now referenced from external files

Lucie10 –

Put in variables for batches on Blanking 1,2 and 3. Schedule reads in as one long list so only runs one line at a time.

3 schedules now read in to alleviate this problem.

Machines now run in parallel

Lucie11 –

More parts added to run entire 32/1 weeks press schedule

Lucie LAS –

Laser facility added to the model

Match rule used to pull in correct parts from stores

Changing to Laser part numbers in Actions on Finish of Laser1 machine

Cycle times of parts now in Actions on Create

Laser stores fed by initial fill file and Blanking 2

Lucie ATTR –

Major change to attribute based model

Part numbers now referenced through one single part in the Witness model from text files. Makes updates and line changes easier and quicker.

Match/Condition rule used to automatically change attribute from Blank to Laser number

```
IF PartnoL1 = start
  PULL from storeL1
ELSE
  IF Las1TYPE = "A765327MGAS"
    IF NPARTS (ELEMENT) = 0
! get first part
    MATCH/CONDITION (Blanknum = "A765324M7UB") storeL1 #(1)
  ELSE
! get second part
    MATCH/CONDITION (Blanknum = "A765324M7GB") storeL1 #(1)
ENDIF
```

Very time consuming to Initial fill the system as the number of items in the model increases

Far too many parts in coil bays

Lucie ATTR2 –

Blanknum introduced as a common variable and attribute that parts are recognised by. Eliminates the use of coil numbers – Assume always available.

Test new part system –

New attributes added to schedules and initial fill files.

Now have Cycle_time, Dieset and Panelstore.

Model not stopping at the end of schedules and just continuing to run extra parts.

04092002

Cycle times given variables so that it changes per part – variables stored as temporary attributes.

05092002

Temporary locations set up to test whether parts are going to the right locations and using the right cycle times and picking up the right variables.

25092002

Coil bays now have a maximum capacity of 3000 parts. Filled with parts with no attributes. Means that blanking lines do not have to search through them and hence save time. Bays only fill up when parts are taken out. Speed of model now vastly improved.

01102002

Parts taken in batches (whole system number of parts has been divided by 10 and the cycle times multiplied by 10 to compensate)

Model runs a lot faster without much loss of accuracy running in 2 minutes instead of 20

Schedules now stopping when finished by using a read file to an Excel spreadsheet. For each machine in the model, the number of lines in the schedule is referenced here. This is read in at the start of the model and when this figure is equal to a system variable, the machine goes into an idle state.

Window 2810

Attempt to make model more tidy. Only show on screen what is actually required by the user.

Press lines cloned from 321 at this stage

All blanking lines run through a pre defined schedule and fill up correct press stores.

With increased data and information in the system, the model is starting to run slower again.

15112002

Model batches divided by 10 and cycle times multiplied by 10 to increase speed without losing too much accuracy.

Reading and following full schedule for Blanking, press and laser1

Model now runs in 1.30 and reflects current press shop conditions for schedule from week 44.

APPENDIX F

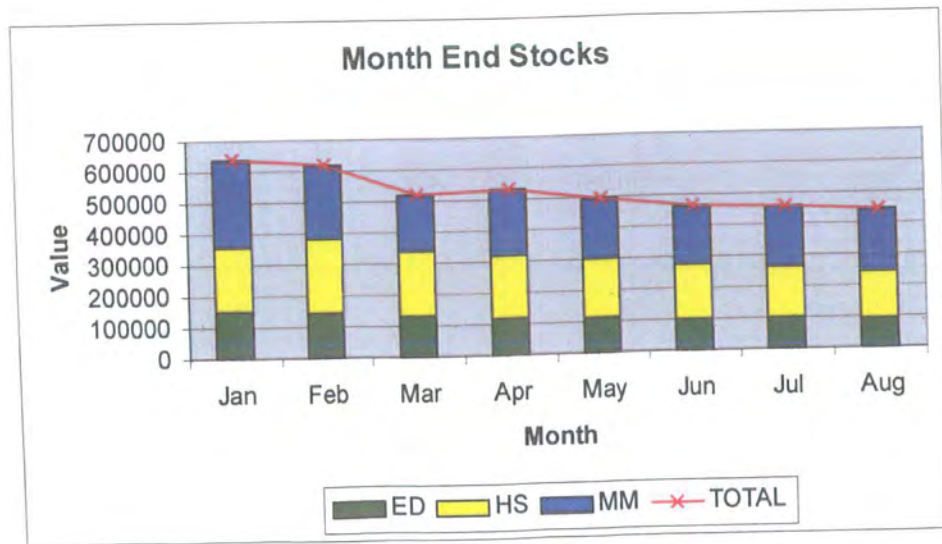
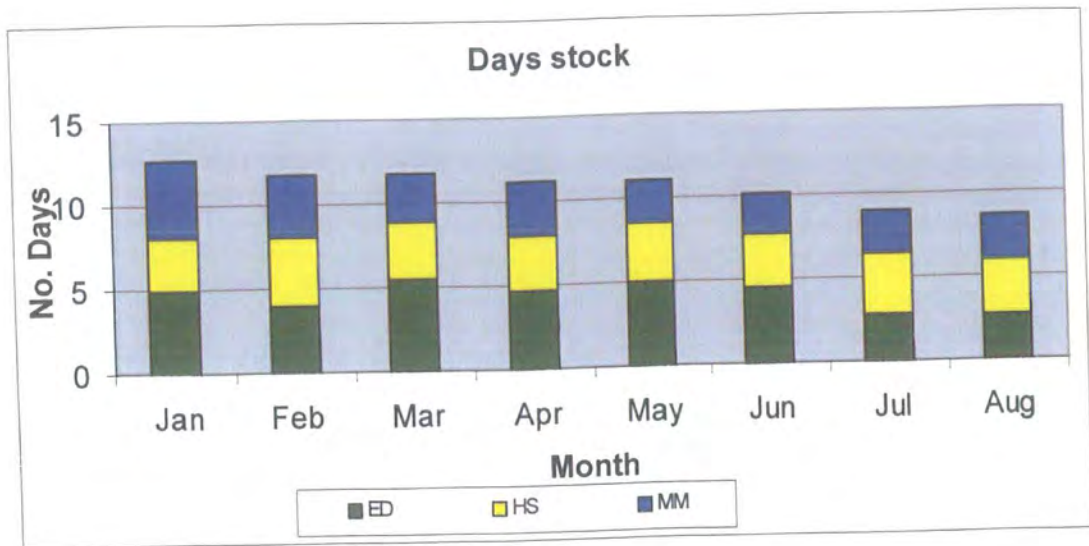

Figure F-1 GIR tables

Figure F-2 Stock Holding

