

Citation for published version:

Airey, M, Harrison, RG, Nicoll, K, Williams, P & Marlton, G 2017, 'Note: A miniature oscillating microbalance for sampling ice and volcanic ash from a small airborne platform', *Review of Scientific Instruments*, vol. 88, no. 8, pp. 086108-086112. <https://doi.org/10.1063/1.4998971>

DOI:

[10.1063/1.4998971](https://doi.org/10.1063/1.4998971)

Publication date:

2017

Document Version

Peer reviewed version

[Link to publication](#)

Publisher Rights

CC BY

This article may be downloaded for personal use only. Any other use requires prior permission of the author and AIP Publishing. The following article appeared in Airey, M. W. Harrison, R. G. Nicoll, K. A. Williams, P. D. Marlton, G. J. (2017) Note: A miniature oscillating microbalance for sampling ice and volcanic ash from a small airborne platform. *Review of Scientific Instruments*, 88(8) and may be found at <https://doi.org/10.1063/1.4998971>

University of Bath

Alternative formats

If you require this document in an alternative format, please contact:
openaccess@bath.ac.uk

General rights

Copyright and moral rights for the publications made accessible in the public portal are retained by the authors and/or other copyright owners and it is a condition of accessing publications that users recognise and abide by the legal requirements associated with these rights.

Take down policy

If you believe that this document breaches copyright please contact us providing details, and we will remove access to the work immediately and investigate your claim.

Note: A miniature oscillating microbalance for sampling ice and volcanic ash from a small airborne platform

M. W. Airey,¹ R. G. Harrison,¹ K. A. Nicoll,¹ P. D. Williams,¹ and G. J. Marlton¹

Department of Meteorology, University of Reading, Reading RG6 6BB, United Kingdom

(Dated: 28 July 2017)

A lightweight and low power oscillating microbalance for in situ sampling of atmospheric ice and volcanic ash is described, for airborne platforms. Using a freely-exposed collecting wire fixed at only one end to a piezo transducer, the instrument collects airborne material. Accumulated mass is determined from change in natural frequency of the wire. The piezo transducer is used in a dual mode to both drive and detect the oscillation. Three independent frequency measurement techniques are implemented with an on-board microcontroller: a frequency sweep, a Fourier spectral method, and a phase-locked loop. These showed agreement to ± 0.3 Hz for a 0.5 mm diameter collecting wire 120 mm long, flown to 19 km altitude on a weather balloon. The instrument is well suited to disposable use with meteorological radiosondes, to provide high resolution vertical profiles of mass concentration.

In extreme situations posing hazards to aircraft, such as after volcanic eruptions, safety-critical decisions require the distribution and concentration of hazardous material to be known. Remote sensing techniques are of limited value for this as they cannot retrieve mass concentrations without prior knowledge of ash properties, such as refractive index^{1,2}. An alternative approach is in situ measurement, and the instrument described here measures the mass directly. Beyond volcanic ash, other applications include detection of ice accretion within supercooled liquid water (SLW) clouds. Our instrument is compact, disposable, lightweight (40 g), and low-power (~ 20 mA from a 9 V supply) designed for rapid-response deployment using a standard weather balloon or other (un)manned airborne platform.

This instrument provides a direct mass determination using the established oscillating microbalance approach, with a wire collector³. Unlike previous implementations which restricted the airflow by actuating devices and enclosures⁴, it uses a freely exposed collecting wire. This both improves the sampling efficiency and yields a response more accurately following theory of a vibrating cylinder fixed at one end. A piezo-electric transducer at the fixed end is used to both drive and detect the oscillation, removing the need for mechanical actuation and associated power consumption and weight. Frequency measurement is implemented through three independent techniques to increase confidence in the measurement. The device is coupled to a meteorological radiosonde which also provides power and data telemetry, through a PANDORA (Programmable ANALogue and Digital Operational Radiosonde Accessory) interface⁵. For the ash collection application, the collecting wire is coated with high-tack adhesive (gasket glue), which can be evenly applied, is effective at cold temperatures, and has been found in laboratory tests to effectively retain ash particles over a range of grain sizes from 10s μm to mm scale.

The collecting wire on our instrument, of 120 mm length and 0.5 mm diameter, is soldered to a piezo transducer with feedback monitoring capability, in contrast to the previous design³, which utilised a drive coil at the attached end of the wire and a pickup coil at the free end. For this new design, the transducer is used in a

dual mode, both to excite oscillations and to measure the oscillations established via a feedback signal. The combination of the wire sensor, a phase-locked loop, and programmable microcontroller, which is illustrated in Figure 1, allows for a great versatility of use that may be tailored to specific uses. Three combined methods of wire vibration frequency detection may be programmed and are described below: direct period measurement via a phase-locked loop (PLL method), a spectral Fast Hartley Transform technique (FHT method), and observation of peak amplitude at driven frequencies (SWEEP method).

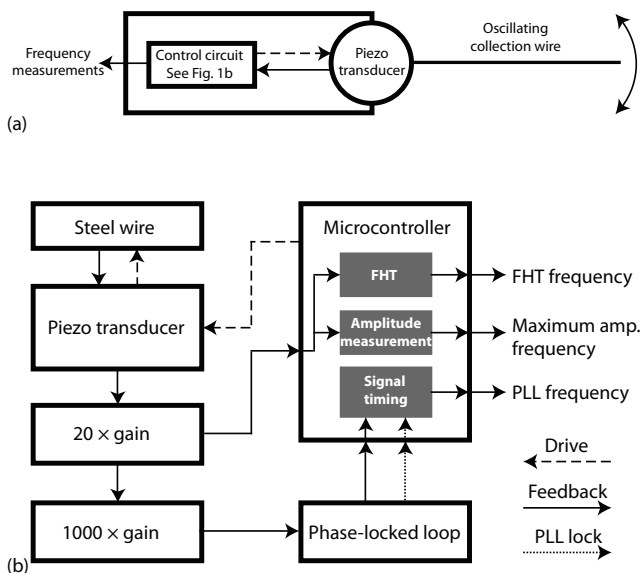

FIG. 1. (a) Sketch of the oscillating microbalance collector. (b) Block diagram to illustrate the main components and signal flow. Dashed lines show optional drive provided to the piezo transducer, dotted lines show the PLL ‘lock’ state signal, and solid lines show the signal received from the wire vibration. White boxes indicate hardware and grey boxes indicate software. Signal flow and component definitions are described in the text.

In use on an airborne platform, the data gathered and processed on the instrument microcontroller are transferred to the PANDORA control board over the I²C protocol at 1 Hz. Four two-byte ‘word’ variables, the os-

calation amplitude and the three independently determined frequency measurements, are transferred during each data request. These data are transmitted with the standard radiosonde data stream and can be retrieved with a commercial radiosonde base station.

The microcontroller used in this device (ATMega 328) has a 32 kB flash memory and a 10 bit analogue to digital convertor (ADC), allowing relatively complex code to be implemented. For the driven operations, timed digital pulses on one of the microcontroller's output pins send a square wave at a defined frequency to the piezo transducer, exciting the wire at that frequency. The vibration of the wire, whether driven or natural, generates a fluctuating voltage at the piezo transducer. This is amplified for the 5 V range of the ADC and is digitised by the microcontroller. The oscillation voltage is also processed through a further gain stage before being applied to a phase-locked loop (PLL), implemented with an HEF4046 integrated circuit. When the PLL is locked to the input signal, a lock indication is provided to trigger the frequency measurement by the microcontroller. The PLL time constant is set to stabilise the input frequencies.

The SWEEP method is achieved by first driving the wire for short bursts (~ 1 s) over a range of frequencies at 1 Hz steps and measuring the amplitude $300 \mu\text{s}$ after each burst has ceased. Successively narrower sweeps (0.5 and 0.1 Hz steps) are then centred upon that peak value obtained to refine the measurement. The finest sweep may then be repeated for as long as measurements are required. This method offers poor temporal resolution (it is slow, with even the finest sweeps taking ~ 10 to 15 s over reasonable ranges of frequencies) but is capable of determining the natural frequency to a precision of ± 0.05 Hz. Figure 2 shows an example amplitude response to a long duration fine sweep (0.1 Hz steps) for a steel wire of 120 mm length, producing a maximum amplitude at 26 Hz. The wire was subsequently coated uniformly with an additional 200 mg of cosmetic nitrocellulose to increase its mass (roughly the same mass as the unladen wire); the dashed line shows the changed amplitude response of the wire, with a new maximum amplitude at 20.5 Hz.

The PLL method measures the frequency directly from the signal. The PLL output indicates the 'lock' state (high or low) from filtering the phase-lock pulses, which identifies when the wire is vibrating at its natural frequency as described above. When the 'lock' state is high, the microcontroller performs a frequency measurement using a reciprocal timing method. Each measurement is derived from the mean of five periods to reduce sampling error. This method is fast, providing continually updated readings at a rate corresponding to the data transfer rate (1 Hz) while the lock state is high. Long duration runs of this method have found a 3σ error of $\sim \pm 0.2$ Hz.

The FHT method uses the Hartley Transform⁶, which is a form of Fourier signal processing that uses only real input and output values to avoid the computation of complex numbers. This makes it a less computationally expensive for implementation on a small microprocessor. Here, the Fast Hartley Transform⁷, is used to determine the natural frequency of the wire by using the amplitude input taken from the first gain stage; a Hann window is applied to the spectrum during the calculations. This al-

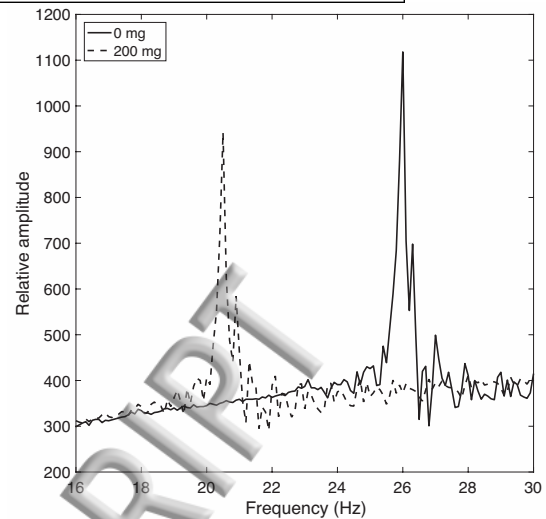

FIG. 2. Relative amplitude frequency response of a 120 mm long, 0.5 mm diameter steel wire after being driven for short pulse intervals (~ 1 s) at 0.1 Hz steps over a range of frequencies. The solid line is for an unladen wire and the dashed line is for the same wire loaded evenly with an additional 200 mg of material.

gorithm can be modified to take up to 256 samples from the amplitude input at any specified sampling frequency. An optimum arrangement for this system is found to be 256 samples at 100 Hz, which provides a spectrum over the frequency range 0 to 50 Hz with ~ 0.4 Hz bin size. This procedure is much faster than the SWEEP method described above, taking only ~ 2.5 s to compute the full 50 Hz range. However, there is a trade off in terms of resolution, as the bin size is ± 0.4 Hz. Figure 3 shows an example spectrum from a vibrating wire with an independently determined natural frequency (using the SWEEP method) of 26 Hz. The ten bins at either extreme of the data range are not counted, resulting in an effective range of ~ 4 to ~ 46 Hz. The frequency range used and initial frequency defined (f_0) was chosen to maximise the output resolution whilst mitigating the boundary effects of the transform, for a practical wire length.

By combining these techniques, it is possible to specify an optimum system in both temporal resolution and measurement precision. The three methods are always found to agree within their limits of uncertainty. The procedure to maximise speed and efficiency is to initially execute an FHT frequency measurement to define a target region on which to apply sweeps for increased precision without the need for long initial coarser runs. The PLL frequency method is employed simultaneously to provide increased data acquisition resolution. Parallel data acquisition has the added advantage of mitigating the risk of data loss. The flexibility inherent in these alternative approaches means that the instrument can be tailored to a specific task, e.g. a high temporal resolution with low precision strategy may be more suited to a task than a low temporal resolution with high precision strategy.

To demonstrate the mass retrieval, the frequency at the peak amplitude was measured as the accreted mass was increased. Uniform (20 ± 5 mg) coatings of cosmetic

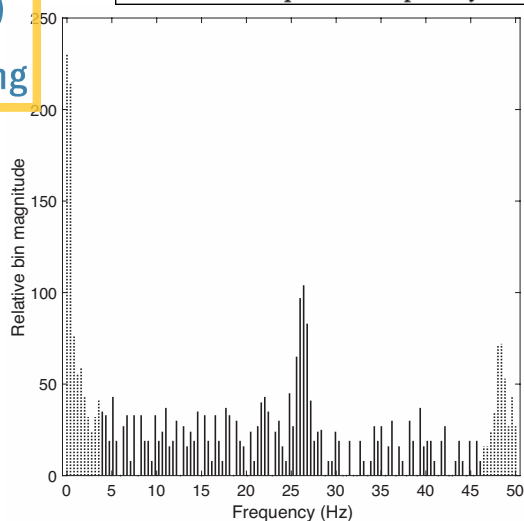

FIG. 3. Histogram of relative bin magnitudes resulting from a 256 point FHT with Hann windowing, sampled at a rate of 100 Hz and grouped into bins of ~ 0.4 Hz for a wire vibrating at a natural frequency of 26 Hz. Dotted bars are for discarded bins and are not counted in the analysis

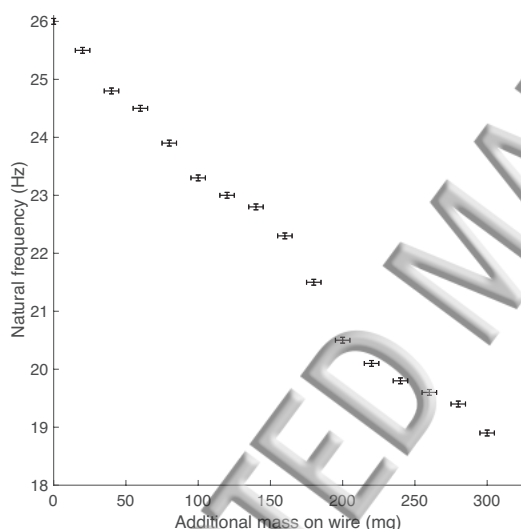

FIG. 4. Response of the 0.5 mm vibrating wire's natural frequency to an incremental mass increase. A linear fit indicates a sensitivity of -0.02 Hz mg^{-1} with a standard error of 0.27 Hz and an R^2 of 0.99. Vertical error bars represent the frequency measurement precision of ± 0.05 Hz and horizontal error bars represent the mass measurement precision of ± 5 mg.

nitrocellulose were consecutively added to the wire. This material allowed consistent mass increments to a higher precision than that afforded by using a natural material

such as ash. Figure 4 shows that the response can be represented by a least square linear fit, giving a sensitivity of $-0.024 \text{ Hz mg}^{-1}$ (-40.6 mg Hz^{-1}), with an R^2 of 0.99. The standard error of the frequency and mass are, respectively, 0.27 Hz and 10.9 mg. Using this response, the associated mass concentration may be calculated through the use of the collection efficiency⁸ of the wire.

In summary, a novel, highly versatile oscillating microbalance has been developed to collect atmospheric material. The sensor wire has a measurement range of >300 mg and the in situ operational effectiveness has been proven in test balloon flights. Data acquired from the instrument during a balloon deployment at Reading to 19 km altitude in clear conditions provided frequency measurements from all three methods, whose mean profiles agreed to ± 0.3 Hz. It has also successfully collected and quantified suspended volcanic ash in the laboratory. The combined use of three independent frequency measurements facilitates tailored use to suit a variety of applications, including measurements of volcanic ash concentration, SLW concentration via ice accretion, and Saharan dust.

ACKNOWLEDGMENTS

This work was funded by the UK Natural Environment Research Council (NERC), grant number NE/P003362/1 (VOLCLAB). KAN acknowledges the support of NERC through Independent Research Fellowship number NE/L011514/1. PDW is funded by The Royal Society, grant number UF130571. The authors thank Stefan Kneifel of the Institute of Geophysics and Meteorology, University of Cologne and Treve Nicol of the Department of Meteorology, University of Reading for useful discussions. The authors also acknowledge the support of Departmental technical staff.

- ¹J. G. C. Ball, B. E. Reed, R. G. Grainger, D. M. Peters, T. A. Mather, and D. M. Pyle, *Journal of Geophysical Research-Atmospheres* **120**, 7747 (2015).
- ²P. N. Francis, M. C. Cooke, and R. W. Saunders, *Journal of Geophysical Research-Atmospheres* **117** (2012), 10.1029/2011JD016788.
- ³G. E. Hill and D. S. Woffinden, *Journal of Applied Meteorology* **19**, 1285 (1980).
- ⁴G. E. Hill, *Journal of Atmospheric and Oceanic Technology* **6**, 961 (1989).
- ⁵R. G. Harrison, K. A. Nicoll, and A. G. Lomas, *Review of Scientific Instruments* **83** (2012), 10.1063/1.3697717.
- ⁶R. V. L. Hartley, *Proceedings of the IRE* **30**, 144 (1942).
- ⁷R. N. Bracewell, *The Hartley Transform* (Oxford University Press, New York, 1986).
- ⁸E. P. Lozowski, J. R. Stallabrass, and P. F. Hearty, *Journal of Climate and Applied Meteorology* **22**, 2053 (1983).

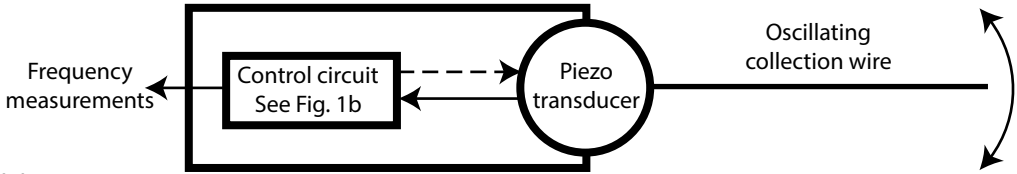

(a)

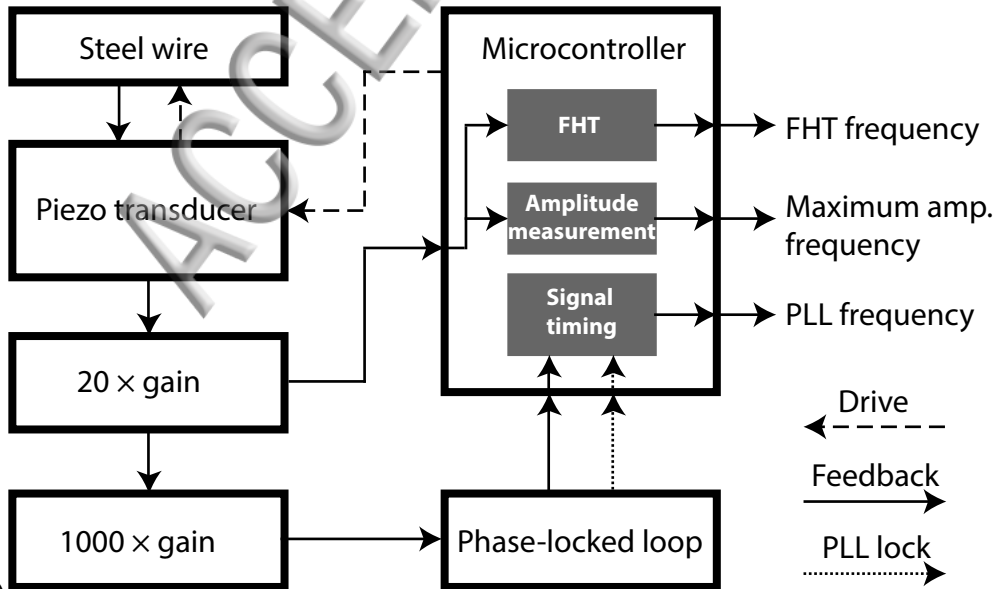

(b)

