

*Citation for published version:*

Xie, M, Zabek, D, Bowen, C, Abdelmageed, M & Arafa, M 2016, 'Wind-driven pyroelectric energy harvesting device', *Smart Materials and Structures*, vol. 25, no. 12, 125023. <https://doi.org/10.1088/0964-1726/25/12/125023>

*DOI:*

[10.1088/0964-1726/25/12/125023](https://doi.org/10.1088/0964-1726/25/12/125023)

*Publication date:*

2016

*Document Version*

Peer reviewed version

[Link to publication](#)

This is an author-created, un-copyedited version of an article published in *Smart Materials and Structures*. IOP Publishing Ltd is not responsible for any errors or omissions in this version of the manuscript or any version derived from it. The Version of Record is available online at [10.1088/0964-1726/25/12/125023](https://doi.org/10.1088/0964-1726/25/12/125023)

**University of Bath**

## **Alternative formats**

If you require this document in an alternative format, please contact:  
[openaccess@bath.ac.uk](mailto:openaccess@bath.ac.uk)

### **General rights**

Copyright and moral rights for the publications made accessible in the public portal are retained by the authors and/or other copyright owners and it is a condition of accessing publications that users recognise and abide by the legal requirements associated with these rights.

### **Take down policy**

If you believe that this document breaches copyright please contact us providing details, and we will remove access to the work immediately and investigate your claim.

## Wind-Driven Pyroelectric Energy Harvesting Device

Mengying Xie<sup>1</sup>, Daniel Zabek<sup>1</sup>, Chris Bowen\*<sup>1</sup>, Mostafa Abdelmageed<sup>2</sup> and Mustafa Arafa<sup>3</sup>

<sup>1</sup>Department of Mechanical Engineering, University of Bath, Bath, United Kingdom

<sup>2</sup>Department of Mechanical Design and Production, Cairo University, Egypt

<sup>3</sup>Mechanical Engineering Department, American University in Cairo, Cairo, Egypt

\*Corresponding author: [c.r.bowen@bath.ac.uk](mailto:c.r.bowen@bath.ac.uk)

### Abstract

*Pyroelectric materials have recently received attention for harvesting waste heat owing to their potential to convert temperature fluctuations into useful electrical energy. One of the main challenges in designing pyroelectric energy harvesters is to provide a means to induce a temporal heat variation in a pyroelectric material autonomously from a steady heat source. To address this issue, we propose a wind-driven pyroelectric energy harvester, in which a propeller is set in rotational motion by an incoming wind stream. The speed of the propeller's shaft is reduced by a gearbox to drive a slider-crank mechanism, in which a pyroelectric material is placed on the slider. Thermal cycling is obtained as the reciprocating slider moves the pyroelectric material across alternative hot and cold zones created by a stationary heat lamp and ambient temperature, respectively. Unlike conventional wind turbines, **the energy harvested by the pyroelectric material is decoupled from the wind flow and no mechanical power is drawn from the transmission; hence the system can operate at low wind speeds (<2 m/s). The open-circuit voltage and closed-circuit current are investigated in the time domain at various wind speeds. The device was experimentally tested under wind speeds ranging from 1.1 m/s to 1.6 m/s and charged an external 100 nF capacitor through a signal conditioning circuit to demonstrate its effectiveness for energy harvesting.***

### Introduction

In energy harvesting systems, heat has always been an attractive source of energy owing to its ubiquity in various industrial applications as well as in the environment. The two most popular approaches to harvest energy from heat rely on thermoelectric and pyroelectric effects. Thermoelectric devices rely on converting temperature gradients into useful energy and have been widely investigated in recent years to convert waste heat into useful energy. Pyroelectric energy harvesting, on the other hand, refers to the ability to convert temperature fluctuations into useful energy. The merits of both approaches have been presented by Sebald et al. [1] and the potential to use the high conversion efficiency of pyroelectric energy harvesting was highlighted. For a comprehensive review of energy harvesting technologies associated with pyroelectric materials and systems, the reader is referred to the works of Bowen et al. [2] and Hunter et al. [3].

At the device level, thermal cycling can either be achieved by mechanically moving a pyroelectric material between stationary hot and cold zones, or by subjecting a fixed specimen to heating and cooling cycles. Recent experimental work by Vaish et al. [4] in which a lead zirconate titanate (PZT) **ferroelectric** ceramic was alternatively dipped in hot and cold oil baths revealed a maximum output voltage of 11.6 V and a power of 5.8  $\mu$ W. Experiments by the same authors [5] were conducted by passing hot and cold air streams over PZT-5H specimens. Thermal

cycling using a motor-driven disk was employed by Erturun et al. [6] to expose and shield a PZT ceramic plate from a heating lamp. A full-wave rectifier bridge circuit in parallel with a resistance and a capacitor was developed for energy storage. The effects of various factors including frequency of temperature change, capacitances, and resistances on stored energy were evaluated. A similar design was presented by Hsiao and Jhang [7] in which cyclic temperature fluctuations in a pyroelectric cell were induced via a motor-driven rotating disk with apertures that separate a PZT pyroelectric cell from a radiating heat lamp.

It can be observed that a considerable amount of research has been conducted under simulated thermal cycling, in which pyroelectric materials are subjected to controlled thermal fluctuations to characterize their behavior. Although these studies provide insight and enable a fundamental understanding of the problem, the development of self-sustained devices is rather challenging since in many practical situations heat, whether coming from industrial waste or the environment, exists predominantly as a steady source or fluctuates at a rate that is too low for an efficient pyroelectric device to operate. This has prompted research to develop devices that operate autonomously at favorable thermal cycling frequencies without the need for external power. In this context, Hunter et al. [8] proposed an innovative design in which a heat source and heat sink were used in conjunction with the thermal expansion/contraction of a resonant bimorph heat-sensitive cantilever beam to induce thermal cycling. Ravindran et al. [9] presented a pyroelectric energy harvester that relies on thermal buckling to drive a bimetallic beam between a heat source and a heat sink. Reference is also made to the work of Ravindran et al. [10], in which an air-filled engine chamber with a bistable membrane oscillates back and forth between a heat source and a heat sink. The output power was 3  $\mu\text{W}$  for a temperature difference of 79.5 K. More recent contributions to enhance the performance of pyroelectric energy harvesting include the use of meshed electrodes [11] and the micropatterning of the surface of pyroelectric materials [12]. These techniques were demonstrated to yield a substantial improvement in the output power through the enhancement of heat transfer, which resulted in faster and higher temperature fluctuations.

Research has also focused on using other energy sources, such as wind, to induce thermal fluctuations in pyroelectric materials. This resulted either in pure pyroelectric solutions that are assisted by another energy source, or in hybrid technologies in which energy is extracted from more than one source, often combining different conversion mechanisms such as pyroelectric and piezoelectric systems; **since all pyroelectric materials are piezoelectric**. As an example, Goudarzi et al. [13] examined a cantilever beam with PZT and lead magnesium niobate – lead titanate (PMN-0.25PT) elements that were subjected to sinusoidal mechanical vibration with heat loads of the same frequency. Hsiao et al. [14] reported on a pyroelectric energy harvester integrating solar radiation with wind power. The device employed a wind-driven generator that also drives a shutter for generating temperature variations in pyroelectric cells using a planetary gear system. The optimal period of the pyroelectric

cells was found to be 35 seconds to harvest the stored energy, about 70  $\mu\text{J}$ , while the rotary velocity of the generator was approximately 31 revolutions per minute at a wind speed of approximately 1 m/s. A wind-assisted design was reported by Krishnan et al. [15] that concentrated solar radiation using a Fresnel lens onto a fixed pyroelectric material and used a chopper disc that was driven by a wind turbine to achieve thermal modulation. The generated energy and power densities produced by PZT-5H were reported to be 6.9  $\text{mJ}/\text{cm}^3/\text{cycle}$  and 421  $\mu\text{W}/\text{cm}^3$ , respectively. Zhang et al. [16] employed wind fluctuation to induce temperature variation in a PZT disc heated by solar radiation. A hybrid device that encompasses the effects of pyroelectric, piezoelectric and shape memory alloys to enhance the thermal energy harvesting was presented by Zakharov et al. [17]. Shape memory alloys were chosen owing to their ability to generate relatively large strains in a narrow temperature range, thereby making the device especially useful for environments with small temperature variations.

Despite the significant contributions that have been achieved in pyroelectric energy harvesting research, it is observed that conceiving autonomous device-level solutions continues to be a major hurdle in the development of self-sufficient harvesters, owing to the difficulty of creating time-domain thermal gradients from steady waste heat sources. One viable approach to achieve thermal cycling is via a secondary source of energy, such as wind or solar. This work addresses this gap by developing a pyroelectric energy harvester that is assisted by a low-velocity wind draft which, for all practical purposes, is too low to drive turbines for power generation. The device consists of a wind-driven propeller that cycles a spinning a ferroelectric pyroelectric plate between hot and cold zones created by a heat lamp. **Since** no mechanical power is extracted from the propeller shaft, the device is envisaged to adapt well for low wind speeds ( $<2$  m/s) available in places with waste heat to be recovered.

### **The pyroelectric effect and properties**

Pyroelectric materials are polar and exhibit a spontaneous polarization in the absence of an applied electric field [2]. In ferroelectric materials, such as the PZT used in this work, the polarisation is a consequence of the alignment of ferroelectric domains that are present due the non-centrosymmetric unit cell in the material. The polarization of the material leads to the presence of a charge on each surface of the material, and the pyroelectric effect is understood from a consideration of the surface charge as the temperature is changed. **If the pyroelectric** is heated ( $dT/dt > 0$ ), there is a decrease in the level of spontaneous polarisation as dipoles lose their orientation. **This fall in polarisation leads** to a decrease in the number of free charges bound to the material surface. If the material is under open circuit conditions the free charges remain at the electrode surface and an electric potential is generated across the material. If the material is under short circuit conditions a current flows between the two polar surfaces of the material. If the pyroelectric is **subsequently** cooled ( $dT/dt < 0$ ) the dipoles regain their orientation leading to an increase in the level of spontaneous polarization, thus reversing **the current** flow under short circuit conditions as free charges **are attracted** to the polar surfaces.

Since there is a requirement for a pyroelectric material to be polar these materials are also piezoelectric and pyroelectrics are a sub-class of piezoelectric materials. Not all piezoelectrics are pyroelectric since materials such as quartz only become polarised as a result of a mechanical stress.

Equation 1 defines the relationship between pyroelectric charge ( $Q$ ) as a result of a temperature change ( $\Delta T$ ) for a material of area ( $A$ ) with pyroelectric coefficient ( $p$ ).

$$Q = p \cdot A \cdot \Delta T \quad (1)$$

Since current is  $dQ/dt$ , Equation 2 provides the pyroelectric current ( $i_p$ ) as a function of the rate of temperature change ( $dT/dt$ ) under short circuit conditions with electrodes orientated normal to the polar direction, which is the case for the element used in this work,

$$i_p = \frac{dQ}{dt} = p \cdot A \cdot \frac{dT}{dt} \quad (2)$$

The capacitance of the pyroelectric material is given by Equation 3,

$$C = \frac{A \cdot \epsilon_{33}^T \cdot \epsilon_0}{h} \quad (3)$$

where  $\epsilon_{33}^T$  is the relative permittivity at constant stress,  $\epsilon_0$  is permittivity of free space and  $h$  is the material thickness. Under open-circuit conditions the pyroelectric charge (Equation. 1), leads to a potential difference ( $V$ ) across the pyroelectric, given by  $Q=CV$ , which leads to Equation 4,

$$V = \frac{p}{\epsilon_{33}^T \cdot \epsilon_0} \cdot h \cdot \Delta T \quad (4)$$

Since under open circuit conditions the pyroelectric element behaves as a capacitor with stored energy  $1/2CV^2$ , the energy ( $E$ ) as a result of a temperature change is given by Equation 5.

$$E = \frac{1}{2} \cdot \frac{p^2}{\epsilon_{33}^T \cdot \epsilon_0} \cdot A \cdot h \cdot (\Delta T)^2 \quad (5)$$

Therefore, for a given area and thickness the energy can be maximised by selecting materials with a high  $\frac{p^2}{\epsilon_{33}^T}$ .

## Design of Wind-Driven Pyroelectric Energy Harvesting Device

Figure 1 shows a schematic illustration of the proposed design of the wind-assisted pyroelectric energy harvester (WiPEH). A wind-driven lightweight propeller drives a slider-crank mechanism through a set of gears. In this way, high-speed rotational motion of the propeller is converted into a low-frequency reciprocating motion of a slider that carries a pyroelectric element, thereby enabling thermal cycling as indicated. Heat is simulated in the laboratory by an infrared lamp. As such, the pyroelectric material is driven slowly into and out of the hot zone created by the heat lamp. A pyroelectric element with a small thickness to surface area ratio is selected so that natural convection with air is the main cooling mechanism [6]. A thermocouple is mounted on the surface of the pyroelectric material to measure temperature fluctuations. The output leads of the pyroelectric material and thermocouple are connected onto a data acquisition system for signal analysis.

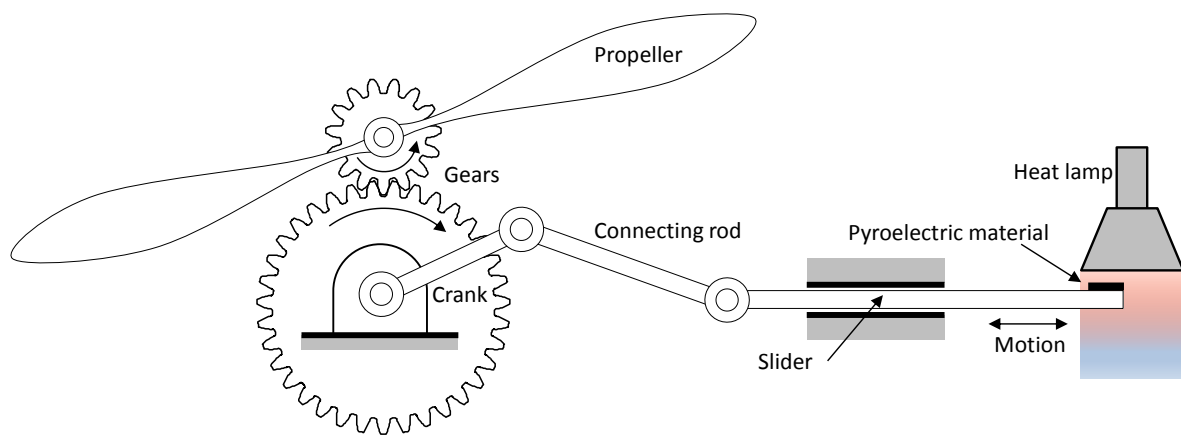

Figure 1. Schematic illustration of proposed energy harvesting device.

Through this design, no mechanical power is extracted from shaft rotation, and hence the design can be effective in applications where the wind velocity is far lower than the cut-in speed for power generation from wind turbines. While a heat lamp is used for laboratory testing, it is envisaged that the design concept can be implemented where industrial waste heat is present along with a wind as an assistive energy source.

## Experimental Work

Figure 2 shows a photograph of the experimental setup. A Dyson fan (AM06 300mm) with a diameter of 10 inches is placed at a distance of 1.2 meters from the propeller to provide a fairly laminar wind flow at controllable speeds. The wind speeds used in this work range from 1.1 m/s to 1.6 m/s, which is considered below the cut-in speed of many conventional wind turbines; for example Fu et al. [18] developed a piezoelectric based device with a cut-in speed of 2.34 m/s. A commercial plastic propeller having a diameter of 12 inches is mounted on a steel shaft which, in turn, is connected to a plastic gearbox having a reduction ratio of 13. The entire setup is mounted on a benchtop for laboratory testing. The wind speed was measured with a Mastech MS6252b wind flow meter. A 2.5

cm diameter piezoelectric lead zirconate titanate element was attached to the end of a light aluminum slider and it moved horizontally during the propeller cycle. The open circuit voltage and closed circuit current were measured using Keithley 6514 electrometer with high input impedance ( $>200T\Omega$ ) for voltage measurements and  $<1fA$  noise. The temperature of the plate surface was measured using a K-type thermocouple; **the thermocouple response time is 0.5 s, which is fast enough to capture the thermal oscillations encountered in this work occurring well below 0.1 Hz.** At the end, **an external capacitor** of 100 nF was charged by this wind assisted pyroelectric harvesting system **to demonstrate harvesting and the rectification system is described later.** A heat lamp (Philips type IR175W, diameter 121 mm) was used to simulate the heat source. The power of the heat lamp was characterized with a calibrated thermal power sensor (THORlabs) at 8 cm distance to the lamp. Figure 3 shows the thermal power that is available for absorption.

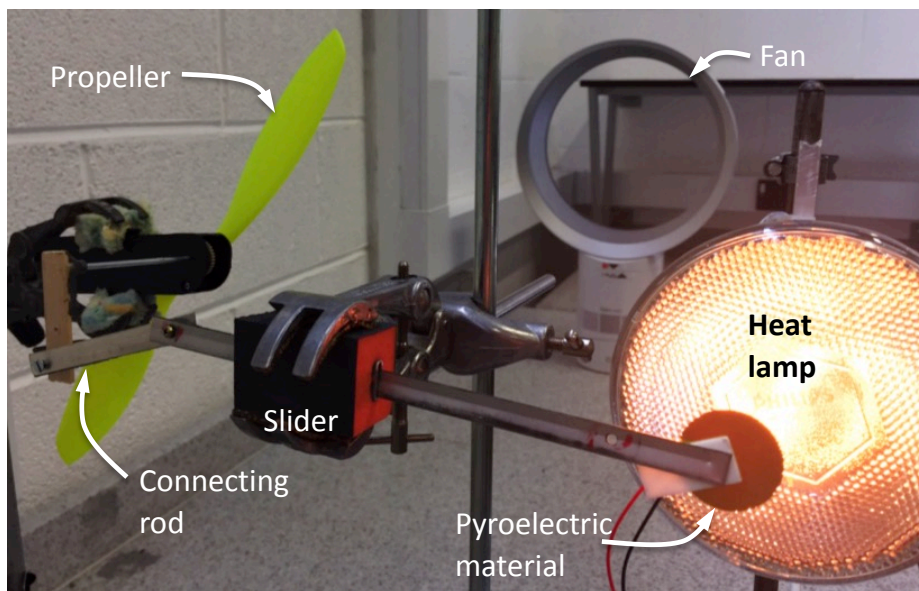

Figure 2. Photograph of experimental setup of harvester.

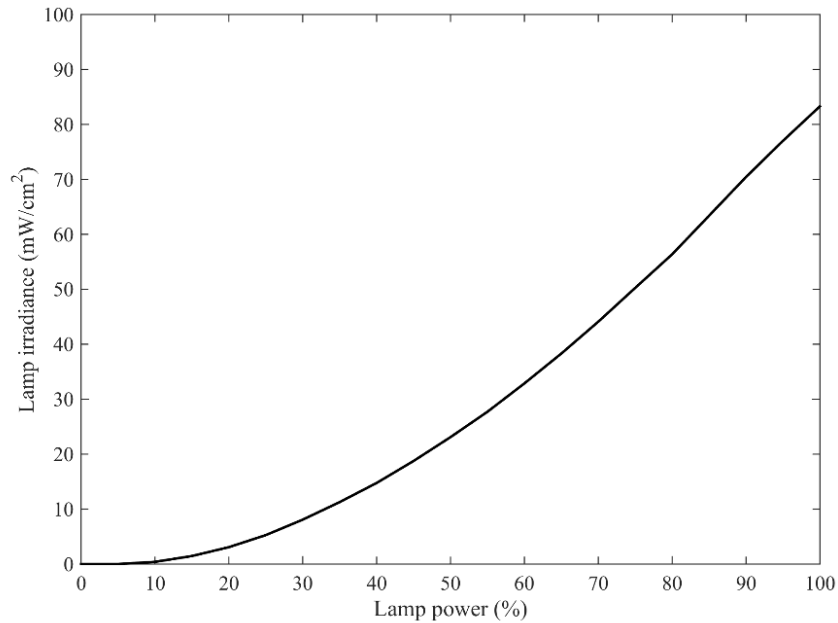

Figure 3. Lamp irradiance intensity with increasing electrical power

To achieve efficient thermal cycling, the pyroelectric material needs to have a large surface area and a small thickness in order to rapidly heat up and cool down. The material chosen in this work is a standard piezoelectric ‘buzzer’, which is constructed from a PZT layer having a diameter of 22 mm and a thickness of 0.2 mm, deposited on a circular brass disc with a diameter of 25 mm and a thickness of 0.3 mm. The conductance at 0.1Hz was approximately  $2 \times 10^{-8}$  S, measured using a Solatron 1260 and 1296 Dielectric Interface. The piezoelectric coefficient,  $d_{33}$ , of the PZT was experimentally measured on a PM25 Take Control Piezometer and was found to be 490 pC/N; this is typical of a relatively ‘soft’ ferroelectric which is both piezoelectric and pyroelectric. The capacitance of the element was 54nF at 1kHz, which is a relative permittivity of 3210 based on the pyroelectric area and thickness and using Equation 3. Temperature measurement was conducted using a K-type thermocouple that is mounted on the surface of the piezoelectric material and the temperature measurement was at a sampling rate of 20 Hz. The thermocouple was electrically insulated from the PZT with a thin coating of lacquer. Short circuit current and open circuit voltage from the PZT sample were measured using an electrometer (Keithley type 6514) and the rate of change of temperature was calculated numerically from the temperature-time data. The output signal was used to charge a capacitor through a signal conditioning circuit to demonstrate the energy harvesting effectiveness. This was achieved using a symmetrical full wave bridged rectifier circuit that was formed from four diodes (Vishay GP02) and a 100 nF (AVX) multilayer ceramic capacitor, as shown in Figure 4.



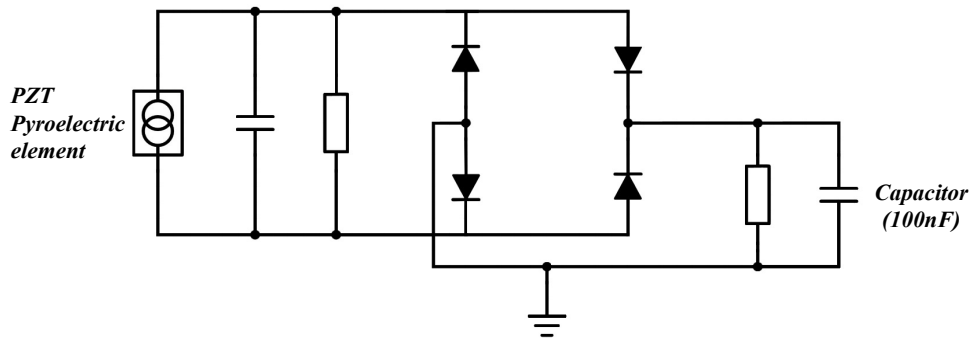

Figure 4. Symmetrical full wave bridged rectifier circuit for the energy harvester.

## Results and discussion

Figure 5 shows the surface temperature of the pyroelectric plate under different wind speeds. It can be seen that temperature changes are relatively consistent, and take place at the slider's motion frequency, which ranges approximately from 2.9 cycles per minute for a wind speed of 1.1 m/s to almost 5.7 cycles per minute for the highest wind speed of 1.6 m/s. It can also be observed that a greater temperature change is obtained at lower wind speeds. This is highlighted in Figure 6a, which shows the average temperature change of half propeller cycle. It **was seen** that the temperature change decreases with the increase in wind speed until 1.5 m/s, hence subsequent measurements **were not taken at wind speeds exceeding 1.5 m/s**. The peak rate of change of temperature ( $dT/dt$ ) has a smaller dependence on wind speed, **see** Figure 6b, and **is dependent** on the heat transfer characteristics of the system.

The measured open circuit voltage of the pyroelectric element under different wind speeds is shown in Fig. 7. From Equation 4 the measured open circuit voltage should be proportional to  $\Delta T$ ; this is also reflected in the form of the temperature-time curve **in Fig. 5 that is similar in form** to that of the voltage-time, **i.e. in terms of the signal consistency and frequencies for the different wind speeds**. Figure 8 shows the measured voltage (**peak to peak**) as a function of wind speed and temperature change. Based on a piezoelectric **element that is 22mm in diameter and 0.2mm thick** with a pyroelectric coefficient of  $-380 \mu\text{C m}^{-2} \text{K}^{-1}$  [2] **and** relative permittivity of 3210 (**similar** to PZT-5H [19]), the **typical  $\Delta T$  values of 4-6 K from Figure 8** should correspond to open circuit voltage of  $\sim 10$ -16V. The measured range of voltages are smaller  $\sim 6$ -9V; differences may relate to the temperature measurement relating to surface temperature, **conductivity losses**, or substrate clamping (the brass substrate) which can reduce the harvested energy [20].

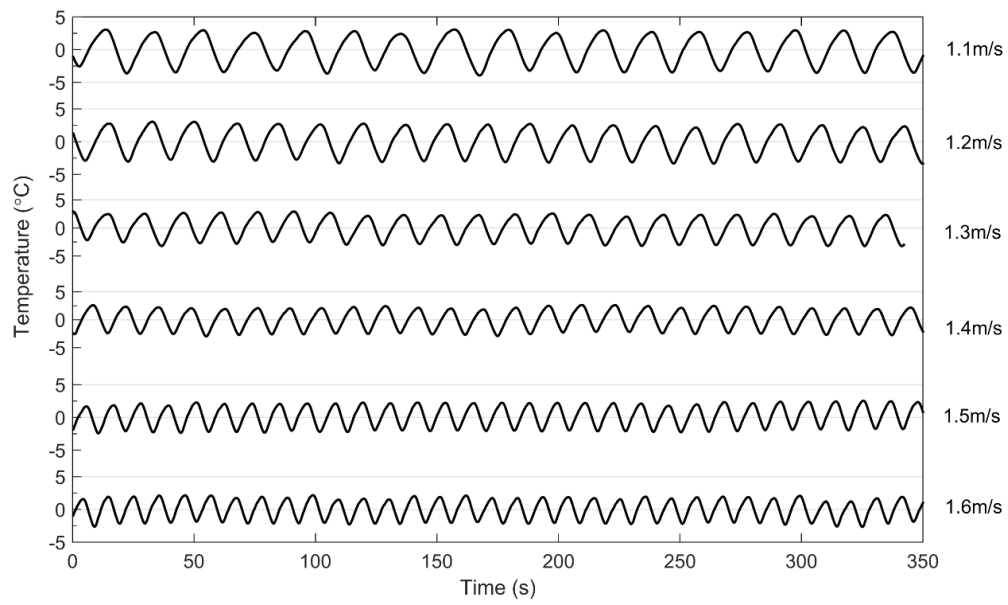
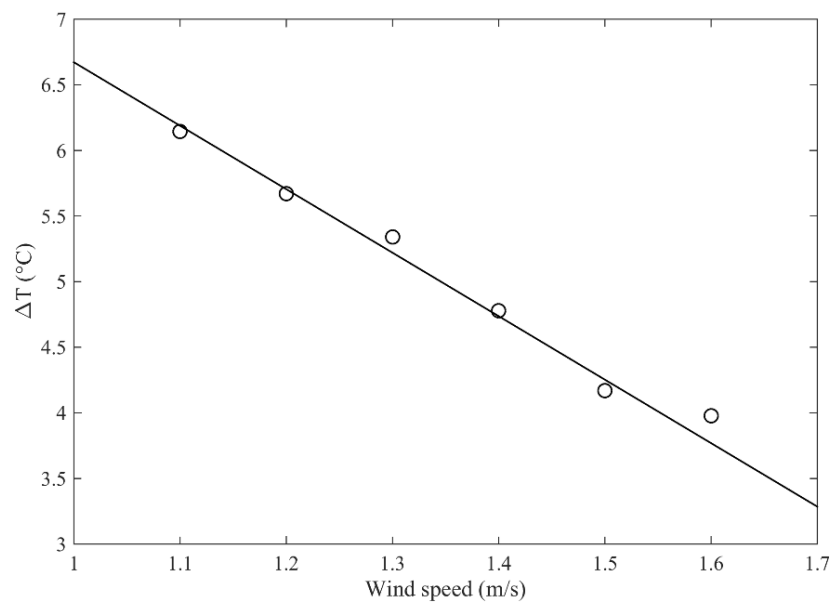
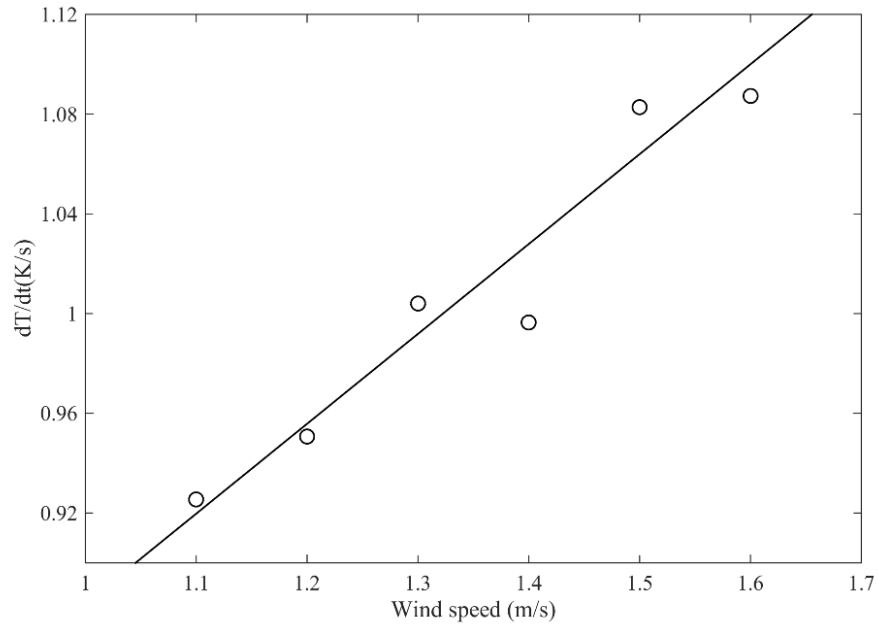

Figure. 5. Measured time-temperature profiles of the pyroelectric with different wind speeds.



(a)



(b)

Figure 6. (a) the temperature change ( $\Delta T$ ) and (b) maximum rate of change of temperature ( $dT/dt$ ) with wind speed.

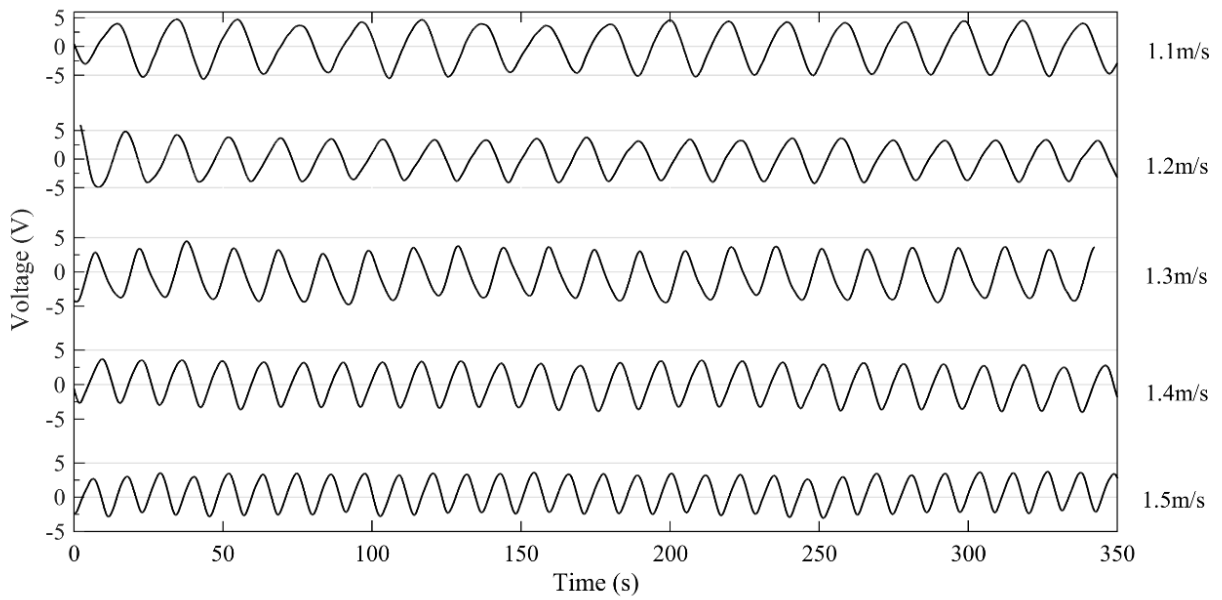

Figure 7. Measured open circuit voltage under different wind speeds.

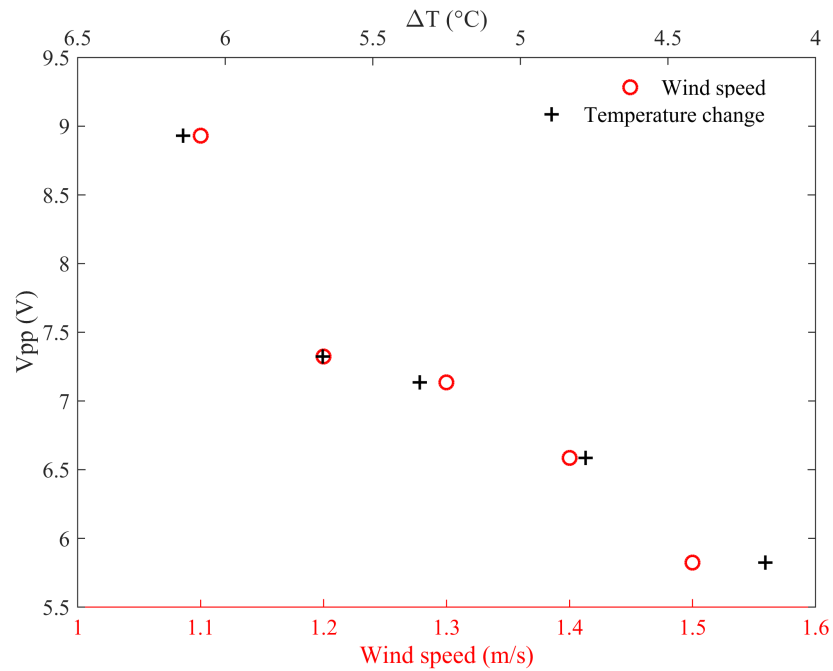
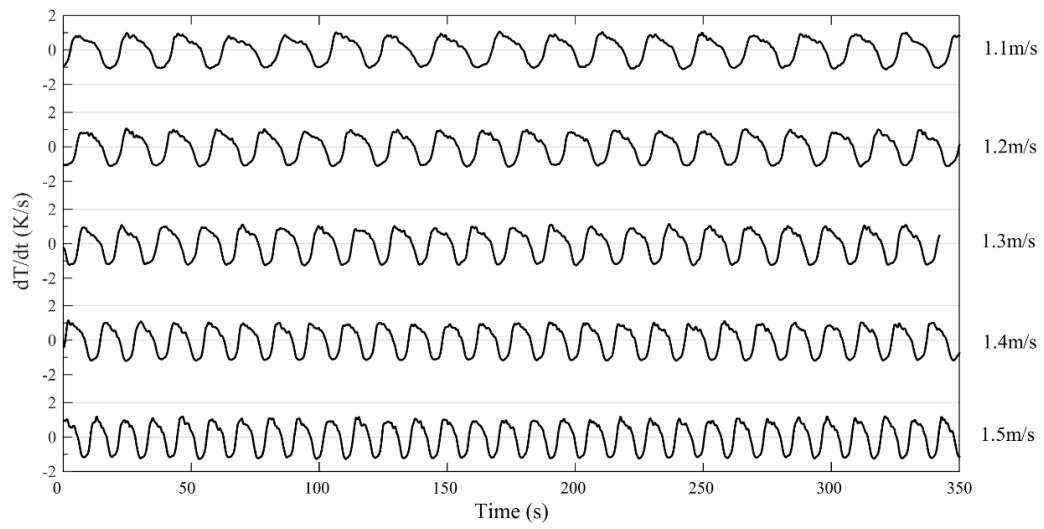

Figure 8. Peak to peak voltage as a function of wind speed and temperature change ( $\Delta T$ ).

Figures 9a and 9b show the rate of temperature change ( $dT/dt$ ) and closed circuit current, respectively, as a function of time. The maximum rate of change of temperature is typically  $1 \text{ K s}^{-1}$  ( $0.92\text{-}1.08 \text{ K s}^{-1}$ ; see Figure 5b) which predicts a closed circuit current of  $144 \text{ nA}$  from Equation 2 based on the pyroelectric area and a typical pyroelectric coefficient of  $-380 \text{ } \mu\text{C m}^{-2} \text{ K}^{-1}$  [2]; this is slightly higher than the peak measured values,  $\sim 90 \text{ nA}$  ( $86\text{-}108 \text{ nA}$ ), yet the waveforms of  $dT/dt$  (Fig. 9(a)) and short circuit current (Fig 9(b)) are commensurate, which agrees with Equation 2.

The charging characteristics of the system are shown in Figure 10, which shows the DC voltage on the external capacitor of the symmetrical full wave bridged rectifier circuit in Figure 4 as a function of time. It can be observed that lower wind speeds lead to faster charging due to the higher temperature changes; based on the external capacitor value of  $100 \text{ nF}$  the energy is  $\sim 10 \text{ } \mu\text{J}$ . The inset in Figure 10 shows the energy generated at different wind speeds, and the results confirm that greater amounts of energy can be obtained at lower wind speeds. This is attributed to the higher voltage, and charge, magnitudes developed at lower cycling speeds.



(a)

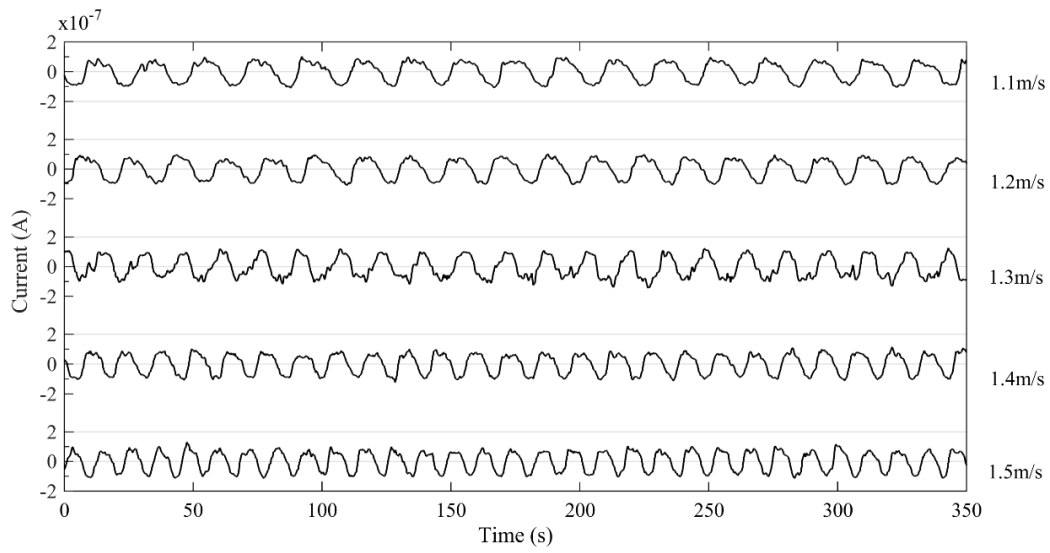

(b)

Figure 9. (a) the rate of temperature change ( $dT/dt$ ) under different wind speed. (b) closed circuit current under different wind speed.

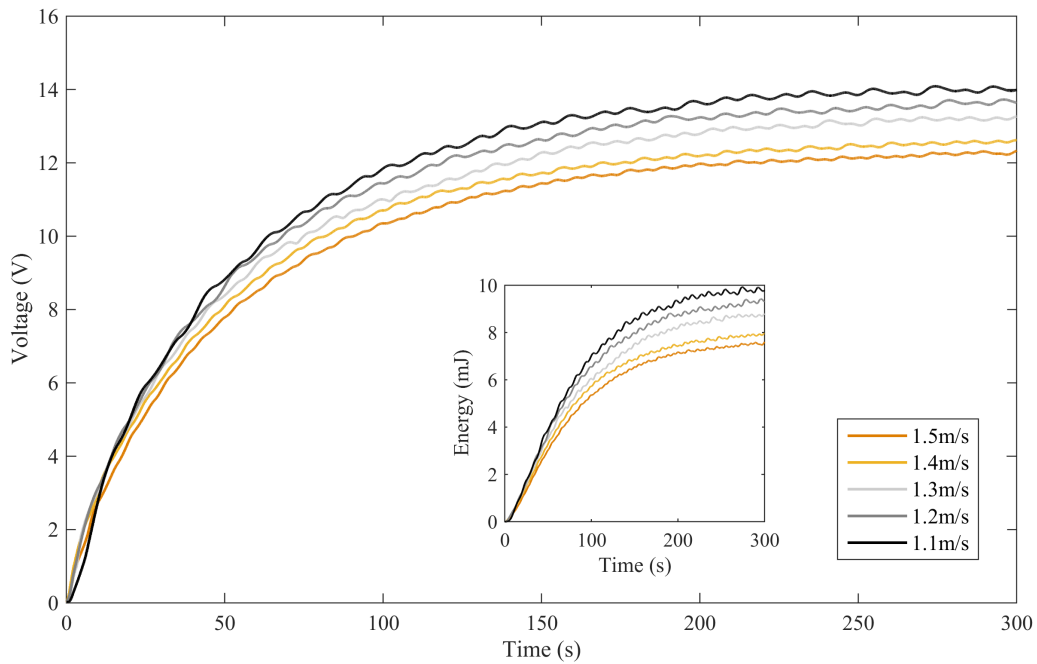

Figure 10. Charging of 100nF capacitor for different wind speeds, the inset shows the energy.

## Conclusions

This work presented a wind-driven pyroelectric energy harvester, in which a low-speed steady wind stream cycled a pyroelectric material between stationary hot and cold zones at frequencies ranging from 2.9 – 5.7 cycles per minute. The device was experimentally characterized by measuring open circuit voltage, closed circuit current as well as surface temperature in the time domain at wind speeds ranging from 1.1 – 1.5 m/s. Cyclic temperature variations in the range of 4-6 K were obtained and the general trend indicated higher temperature change at lower wind speeds. This is attributed to the heat transfer characteristics of the system as lower frequencies of mechanical motion provide more effective heating and cooling cycles. Waveforms of the output voltage were found to be in agreement with time-domain temperature variations, and the generated peak to peak voltage ranged from 6 - 9 V, which compares favorably with theoretical predictions. Closed circuit currents ranging from 86 – 108 nA were obtained and were also shown to compare well with time-domain plots of the rate of temperature change. The ability of the device to charge a 100 nF capacitor through a signal conditioning circuit yielded approximately 10 $\mu$ J in 300 seconds, with better charging characteristics at lower wind speeds. Further improvements could involve using materials with higher figures of merit (Equation 5), such as relaxor-ferroelectric 0.75Pb(Mg<sub>1/3</sub>Nb<sub>2/3</sub>)O<sub>3</sub>-0.25PbTiO<sub>3</sub> (PMN-025PT) single crystal poled along [1 1 1] of the perovskite unit cell, the heat capacity of the material and utilising non-reflective coatings to increase the temperature changes.

It is envisaged that the proposed pyroelectric energy harvester can be employed for waste heat recovery in applications where a slight wind draft is present to enable autonomous operation. The required wind speed is far

better than the cut-in speed of many conventional wind turbines. This separates the application domain of the proposed device from other traditional technologies, such as wind turbines or photovoltaic cells, which are known to perform better in environments abundant with wind or solar energy.

It is emphasized that the present device does not rely on power generation from wind, and wind flow is only needed to set the propeller in steady-state motion to enable thermal cycling. Accordingly, the energy harvested by the pyroelectric material is decoupled from the wind flow, and the only energy extracted by wind is that required to overcome friction in the mechanical parts. These were made of lightweight materials, to keep power consumption and losses down to a minimum. This work is therefore aimed for low wind speeds (< 2 m/s) where no wind turbines are expected to operate.

### Acknowledgement

Xie, Bowen and Zabek have received funding from the European Research Council under the European Union's Seventh Framework Programme (FP/2007-2013) / ERC Grant Agreement no. 320963 on Novel Energy Materials, Engineering Science and Integrated Systems (NEMESIS).

### References

- [1]. Sebald, G., Guyomar, D. and Agbossou, A., "On thermoelectric and pyroelectric energy harvesting," *Smart Materials and Structures* 18 (2009) 1 – 7.
- [2]. Bowen, C.R., Taylor, J., LeBoulbar, E., Zabek, D., Chauhan, A. and Vaish, R., "Pyroelectric Materials and Devices for Energy Harvesting Applications," *Energy and Environmental Science* 7 (2014) 3836 – 3856.
- [3]. Hunter, S.R., Lavrik, N.V., Mostafa, S., Rajic, S. and Datskos, P.G., "Review of pyroelectric thermal energy harvesting and new MEMs based resonant energy conversion techniques," *Proceedings of the SPIE Vol. 8377: Energy Harvesting and Storage: Materials, Devices, and Applications III*, April 23, 2012, Baltimore, Maryland, USA.
- [4]. Vaish, M., Sharma, M., Vaish, R. and Chauhan, V.S., "Experimental Study on Waste Heat Energy Harvesting using Lead Zirconate Titanate (PZT-5H) Pyroelectric Ceramics," *Energy Technology* 3 (7) (2015) 768 – 773.
- [5]. Vaish, M., Sharma, M., Vaish, R. and Chauhan, V.S., "Electrical energy generation from hot/cold air using pyroelectric ceramics," *Integrated Ferroelectrics* 167 (2015) 90 – 97.
- [6]. Erturun, U., Green, C., Richeson, M.L. and Mossi, K., "Experimental Analysis of Radiation Heat-based Energy Harvesting through Pyroelectricity," *Journal of Intelligent Material Systems and Structures* 25 (14) (2014) 1838 – 1849.
- [7]. Hsiao, C.-C. and Jhang, J.-W., "Pyroelectric Harvesters for Generating Cyclic Energy," *Energies* 8 (2015) 3489 – 3502.
- [8]. Hunter, S.R., Lavrik, N.V., Bannuru, T., Mostafa, S., Rajic, S. and Datskos, P.G., "Development of MEMS based pyroelectric thermal energy harvesters," *Proceedings of the SPIE Vol. 8035: Energy Harvesting and Storage: Materials, Devices, and Applications II*, April 25 – 29, 2011, Orlando, Florida, USA.
- [9]. Ravindran, S.K.T., Kroener, M. and Woias, P., "Standalone Pyroelectric Harvester for Thermal Energy Harvesting" *Proceedings of PowerMEMS 2012*, Atlanta, GA, USA, December 2-5, 2012, 80 – 83.
- [10]. Ravindran, S.K.T., Huesgen, T., Kroener, M. and Woias, P., "A self-sustaining pyroelectric energy harvester utilizing spatial thermal gradients" *Proceedings of the 16<sup>th</sup> International Solid-State Sensors, Actuators and Microsystems Conference (TRANSDUCERS)*, 5 – 9 June, 2011, Beijing, China, pages 657 – 660.
- [11]. Zabek, D., Bowen, C.R. and Taylor, J., "Electrical Capacitance with Meshed Electrodes for Piezo- and Pyroelectric Energy Harvesting Application," *Proceedings of the 2015 Joint IEEE International Symposium on*

Integrated Functionalities and Piezoelectric Force Microscopy Workshop (ISAF/ISIF/PFM), 24-27 May 2015, Singapore.

- [12]. Zabek, D., Taylor, J., Le Boulbar, E. and Bowen, C.R., "Micropatterning of Flexible and Free Standing Polyvinylidene Difluoride (PVDF) Films for Enhanced Pyroelectric Energy Transformation," *Advanced Energy Materials* 5 (2015) 1401891 (6 pages).
- [13]. Goudarzi, M., Niazi, K. and Besharati, M.K., "Hybrid Energy Harvesting From Vibration and Temperature Gradient By Pzt And Pmn-0.25pt Ceramics," *Materials Physics and Mechanics* 16 (2013) 55-65.
- [14]. Hsiao, C.-C., Jhang, J.-W. and Siao, A.-S., "Study on Pyroelectric Harvesters Integrating Solar Radiation with Wind Power," *Energies* 8 (2015) 7465 – 7477.
- [15]. Krishnan, S.H., Ezhilarasi, D. and Umapathy, M., "Pyroelectric-Based Solar and Wind Energy Harvesting System," *IEEE Transactions on Sustainable Energy* 5 (1) (2014) 73 – 81.
- [16]. Zhang, Q., Agbossou, A., Feng, Z., and Cosnier, M., "Solar micro-energy harvesting with pyroelectric effect and wind flow," *Sensors and Actuators A* 168 (2011) 335 – 342.
- [17]. Zakharov, D., Gusarov, B., Gusarova, E., Viala, B., Cugat, O., Delamare, J. and Gimeno, L., "Combined Pyroelectric, Piezoelectric and Shape Memory Effects for Thermal Energy Harvesting," *Journal of Physics: Conference Series* 476 (2013) 012021.
- [18]. Fu, H., D'Auria, M., Dou, G. and Yeatman, E.M., "Dynamic Regulating Mechanism for Increased Airflow Speed Range in Micro Piezoelectric Turbines," *Proceedings of MEMS 2016, Shanghai, China, 24-28 January 2016*, 1220 – 1223.
- [19]. Morgan Electro Ceramics Technical Publication TP-226: Properties of Piezoelectricity Ceramics, available online: <http://www.morgantechnicalceramics.com/sites/default/files/documents/tp226.pdf>
- [20]. Atulasimha, J., Xie, J., Richeson, M. and Mossi, K.M., "Pyroelectric Materials: Scaling of Output Power with Dimensions and Substrate Clamping," *Proceedings of the ASME 2009 Conference on Smart Materials, Adaptive Structures and Intelligent Systems (SMASIS 2009) September 21-23, 2009, Oxnard, California, USA*.