



Citation for published version:

Ma, K, Li, F & Aggarwal, R 2016, 'Quantification of additional reinforcement cost driven by voltage constraint under three-phase imbalance', *IEEE Transactions on Power Systems*, vol. 31, no. 6, pp. 5126-5134.
<https://doi.org/10.1109/TPWRS.2016.2515499>

DOI:

[10.1109/TPWRS.2016.2515499](https://doi.org/10.1109/TPWRS.2016.2515499)

Publication date:

2016

Document Version

Peer reviewed version

[Link to publication](#)

Publisher Rights

Unspecified

© 2016 IEEE. Personal use of this material is permitted. Permission from IEEE must be obtained for all other users, including reprinting/ republishing this material for advertising or promotional purposes, creating new collective works for resale or redistribution to servers or lists, or reuse of any copyrighted components of this work in other works.

University of Bath

Alternative formats

If you require this document in an alternative format, please contact:
openaccess@bath.ac.uk

General rights

Copyright and moral rights for the publications made accessible in the public portal are retained by the authors and/or other copyright owners and it is a condition of accessing publications that users recognise and abide by the legal requirements associated with these rights.

Take down policy

If you believe that this document breaches copyright please contact us providing details, and we will remove access to the work immediately and investigate your claim.

Quantification of Additional Reinforcement Cost Driven by Voltage Constraint under Three-Phase Imbalance

Kang Ma, Furong Li, *Senior Member, IEEE*, Raj Aggarwal, *Senior Member, IEEE*

Abstract—Three-phase imbalance causes uneven voltage drops across LV transformers and main feeders. With continuous load growth, the lowest phase voltage at the feeder end determines the voltage spare room, which is lower than if the same power were transmitted through balanced three phases. This imbalance causes additional reinforcement cost (ARC) beyond the balanced case. This paper proposes novel ARC models for a typical LV circuit based on primary-side voltage and current measurements. All models except the accurate model not only enable efficient utility-scale ARC calculations with sufficient accuracy but also remove the need for phasor measurements. The ARC models calculate voltage-driven reinforcement costs for the imbalanced case and the benchmark, i.e. the balanced case, where the ARC is the difference between the above values. The models include: 1) an accurate ARC model considering imbalance in both magnitudes and phase angles; 2) a semi-simplified ARC model assuming balanced phase angles; 3) a fully simplified model assuming a purely resistive LV circuit and a unity power factor; and 4) linearized ARC models considering the imbalance degree for two special cases. Test case proves that: i) the ARC is a monotonically increasing, convex (concave) but close-to-linear function of current (voltage) imbalance; ii) voltage imbalance has a greater impact on ARCs than current imbalance; iii) a higher degree of current imbalance and/or a deteriorating power factor reduce the accuracy of the fully simplified model; and iv) the accuracy of the semi-simplified model is higher in the case of voltage angle imbalance than in the case of current angle imbalance.

Index Terms—power transformers, power system economics, power distribution

I. NOMENCLATURE

K	Transformer turning ratio
Z_t	Transformer equivalent impedance referred to the secondary side
I_a, I_b, I_c	Secondary-side phase currents
I_A, I_B, I_C	Primary-side phase currents
I_{AB}, I_{BC}, I_{CA}	Primary-side line currents
V_{AB}, V_{BC}, V_{CA}	Primary-side line voltages

V_{an}, V_{bn}, V_{cn}	Secondary-side phase-to-neutral voltages
V_{ta}, V_{tb}, V_{tc}	Secondary-side phase voltages of the ‘ideal’ transformer
V_{lower}	The statutory lower limit for phase voltage
V_{LL}, I_{LL}	Primary-side line voltage and current in the three-phase balanced gauge case
Z_f	The equivalent impedance of a LV main feeder
Z_0	The impedance per unit length of a LV main feeder
Z_{eq}	The equivalent impedance of a combined Dyn11 transformer and a feeder
R_{eq}, X_{eq}	The real and imaginary parts of Z_{eq} , respectively
Z_{dij}	The complex element of the three-phase equivalent impedance matrix
R_{dij}, X_{dij}	The real and imaginary parts of Z_{dij} , respectively
IC	Investment cost
r	Annual load growth rate
d	Discount rate
n_{ϕ}	The number of years it takes for the phase voltage $V_{\phi n}$ to drop to the statutory lower limit
PV_B, PV_{IB}	The present values of the voltage-driven reinforcement costs for the three-phase balanced case and imbalanced case, respectively
θ_A, θ_B	The phase angles for I_A and I_B , respectively
$\theta_{AB}, \theta_{BC}, \theta_{CA}$	The phase angles for V_{AB}, V_{BC} and V_{CA} , respectively

II. INTRODUCTION

Three phase imbalance is widespread across low voltage (LV) distribution networks. A key impact of three-phase imbalance is the inefficient utilization of three-phase network assets [1]. For three-phase Delta-Wye-N-11 (Dyn11) connected LV transformers popular in the UK, the phase imbalance manifests itself as the measured voltage imbalance [2, 3] and the current imbalance [4] on the primary side. Such

This paragraph of the first footnote will contain the date on which you submitted your paper for review.

K. Ma is with University of Bath, UK (e-mail: K.Ma@bath.ac.uk).
 Prof. F. Li is with University of Bath (email: F.Li@bath.ac.uk).

an imbalance is passed onto the secondary side with voltage drops through the transformer winding. From the secondary side, the unbalanced phase voltages further drop along LV main feeders [5]. The voltage drop, coupled with three phase imbalance, brings cost implications especially for high demand urban circuits and low demand rural circuits (with higher impedance than the urban counterparts). With continuous demand growth, the lowest phase voltage along the LV main feeders determines the voltage spare room towards the statutory lower voltage limit, and the spare room is lower than if the same power were transmitted through balanced three phases. The reduction in voltage spare room causes the feeder-end voltage to reach the lower limit earlier, thus triggering earlier network reinforcements and leading to an additional reinforcement cost (ARC) driven by voltage constraints.

When facing the three-phase imbalance issue, a common approach for the distribution network operators (DNOs) to address the issue is ‘doing nothing but waiting until network investments become necessary’, i.e. a passive option [6], of which the ARC is a key cost element. The passive option is popular in the absence of customers’ phase connectivity knowledge, as is the case in the UK. For DNOs to appraise the passive option, the ARC has to be properly modelled and quantified – this is the focus of this paper. In future, with increasing knowledge of customers’ phase connectivity, it is possible to use alternative proactive options for short-term phase balancing, e.g. demand side responses. And the ARC quantified in this paper will serve as the benchmark for comparison.

Existing work on LV network reinforcement costs is limited. Thermal and voltage limits are the major drivers for network reinforcements, and the resulting costs were quantified on a UK-wide scale using a triangular distribution model [7]. However, it does not consider voltage drop across the LV transformer or three-phase imbalance. Network investment costs are widely integrated into the objective functions of the LV network planning models [8-12]. E. Matlotse et al. proposed a pricing mechanism based on the long-run incremental cost of reactive compensation devices for tackling voltage issues [13, 14]. All these studies assume that the LV networks have balanced three phases, which is not the case in reality.

Previous papers identified the impact of three-phase imbalance on network reinforcements qualitatively [1, 15], but not quantitatively. We recently published a paper on the quantification of the ARC driven by thermal constraints considering three phase imbalance for main feeders and LV transformers [16]. Now we extend the concept to quantify ARCs driven by voltage constraints under three phase imbalance for a typical LV circuit. For the first time, this paper proposes novel ARC models for a typical LV circuit based on the line voltage and phase current measurements on the primary side (11kV). The novel ARC models include: i) an accurate ARC model that quantifies the voltage-driven reinforcement costs for the imbalanced case and the benchmark, i.e. the balanced case. The ARC is the difference between the above costs for the two cases; ii) a semi-simplified ARC model where

the calculations of voltage-driven reinforcement costs for the imbalanced case and the balanced case are partially simplified based on the assumption of phase angle balance; iii) a fully simplified ARC model for calculating the voltage-driven reinforcement costs for the imbalanced case and the balanced case based on the assumption of a purely resistive LV circuit and a unity power factor; and iv) linearized ARC models considering the imbalance degree for two special cases. The simplifications not only remove the requirement for phasor measurements but also allow for the ARC calculations to be conducted efficiently on a utility scale with sufficient accuracy, enabling DNOs to better understand the voltage-driven cost implications in three-phase imbalanced LV networks.

The remainder of this paper is organized as follows: Section III introduces a typical LV circuit model as a combination of a Dyn11 connected LV transformer model and a main feeder model; based on the circuit model, Sections IV, V, and VI present an accurate ARC model, a semi-simplified model, and a fully simplified model, respectively; Section VII presents two linearized ARC models for two special cases; Section VIII conducts a case study; and Section IX concludes the paper.

III. TYPICAL LV CIRCUIT MODEL

A typical LV circuit is a combination of a Dyn11 connected transformer and a LV three-phase main feeder, which is a common configuration in the UK [17]. This paper adopts the transformer model as ‘ideal’ windings connected with equivalent impedance referred to the secondary side. The symmetrical LV main feeder is modelled as equivalent impedance which gives the same voltage drop at the feeder end for the phase current at the starting point of the feeder. The typical LV circuit model and its mathematical representation are presented based on the above transformer and main feeder models.

A. Dyn11 Connected LV Transformer Model

The Dyn11 connected transformer model is presented in Fig. 1 [18].

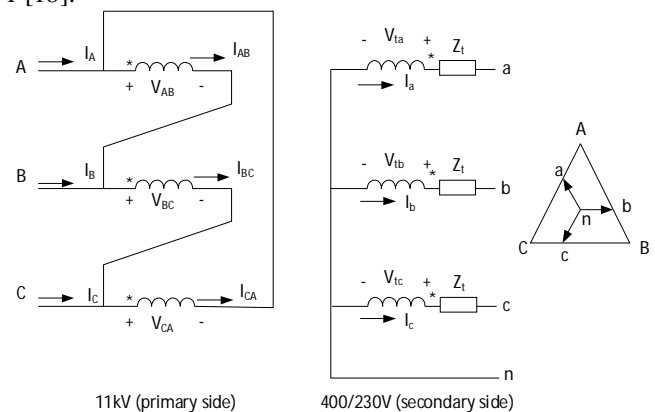

Fig. 1. Dyn11 connected transformer model [18].

The study assumes that the transformer tap is set to achieve the highest voltage on the secondary side – it is therefore not an option to increase the voltage on the secondary side by further tap changes.

It is assumed that the phase currents and line voltages on the

primary side are measured. The mathematical model of the Dyn11 transformer is adopted from [19]. Given that only two variables among \dot{I}_A , \dot{I}_B and \dot{I}_C are independent, the secondary-side phase voltages are expressed as a function of the primary-side line voltages and phase currents, which are available from monitoring devices on the primary side.

$$\begin{bmatrix} \dot{V}_{an} \\ \dot{V}_{bn} \\ \dot{V}_{cn} \end{bmatrix} = \begin{bmatrix} 1/K & & \\ & 1/K & \\ & & 1/K \end{bmatrix} \begin{bmatrix} \dot{V}_{AB} \\ \dot{V}_{BC} \\ \dot{V}_{CA} \end{bmatrix} + \begin{bmatrix} -\frac{1}{3}KZ_t & \frac{1}{3}KZ_t & -\frac{1}{3}KZ_t \\ -\frac{1}{3}KZ_t & -\frac{2}{3}KZ_t & -\frac{1}{3}KZ_t \\ \frac{2}{3}KZ_t & \frac{1}{3}KZ_t & -\frac{1}{3}KZ_t \end{bmatrix} \begin{bmatrix} \dot{I}_A \\ \dot{I}_B \\ 0 \end{bmatrix} \quad (1)$$

where any variable with a dot above is a phasor.

B. LV Main Feeder Model

A main feeder refers to a 3-phase symmetrical backbone branch starting from an LV substation downwards. This paper considers the UK's three-phase LV systems, where three-phase laterals extending from a main feeder feed customers directly. It should be noted that this work is limited to a conventional scenario with a low penetration of distributed generation.

An example of currents distribution along a LV main feeder is depicted in Fig. 2, where the current monotonically drops towards the feeder end because of the customers' extractions of the current through laterals.

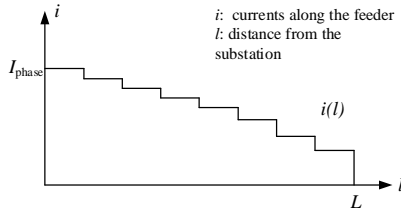

Fig. 2. An example of currents distribution along a main feeder

The voltage drop at the feeder end is given by

$$\Delta V = Z_0 \int_0^L i(l) dl \quad (2)$$

where Z_0 denotes the impedance per unit length.

The equivalent impedance of the main feeder is the one that gives the same feeder-end voltage drop for the phase current at the starting point of the feeder, i.e. the secondary side of the LV transformer.

$$Z_f = \frac{Z_0 \int_0^L i(l) dl}{I_{phase}} \quad (3)$$

where I_{phase} denotes the phase current at the starting point of the feeder.

Without monitoring along the LV feeder, it is assumed that i) customers are distributed evenly along the feeder; and ii) that the phase currents decrease linearly along the main feeder, from I_{phase} at the starting point of the feeder down to zero at the feeder end. This gives

$$i(l) = I_{phase} - \frac{I_{phase}}{L} l \quad (4)$$

Therefore,

$$Z_f = 0.5Z_0L \quad (5)$$

C. Typical LV Circuit Model

A typical LV circuit model is presented in Fig. 3 as a combination of a Dyn11-connected LV transformer and a main feeder.

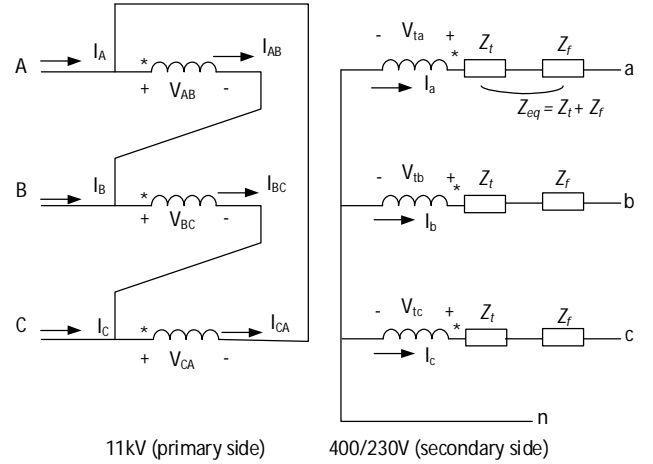

Fig. 3. Typical LV circuit model as a combination of Dyn11 transformer and LV main feeder

It should be noted that this paper considers a low level of voltage and current imbalance (the degree of the current magnitude imbalance being less than 10% and that of the voltage magnitude imbalance being less than 4.0%), based on an approximate line model introduced in [19]. The total equivalent impedance Z_{eq} is therefore the summation of the transformer impedance referred to the secondary side and the feeder's equivalent impedance. The mathematical model for the LV circuit is given by

$$\begin{bmatrix} \dot{V}_{an} \\ \dot{V}_{bn} \\ \dot{V}_{cn} \end{bmatrix} = \begin{bmatrix} 1/K & & \\ & 1/K & \\ & & 1/K \end{bmatrix} \begin{bmatrix} \dot{V}_{AB} \\ \dot{V}_{BC} \\ \dot{V}_{CA} \end{bmatrix} + \begin{bmatrix} -\frac{1}{3}KZ_{eq} & \frac{1}{3}KZ_{eq} & -\frac{1}{3}KZ_{eq} \\ -\frac{1}{3}KZ_{eq} & -\frac{2}{3}KZ_{eq} & -\frac{1}{3}KZ_{eq} \\ \frac{2}{3}KZ_{eq} & \frac{1}{3}KZ_{eq} & -\frac{1}{3}KZ_{eq} \end{bmatrix} \begin{bmatrix} \dot{I}_A \\ \dot{I}_B \\ 0 \end{bmatrix} \quad (6)$$

where the three-phase equivalent impedance matrix is given by

$$\begin{aligned} [Z_{dij}] &= [R_{dij} + jX_{dij}] \\ &= \begin{bmatrix} -\frac{1}{3}KZ_{eq} & \frac{1}{3}KZ_{eq} & -\frac{1}{3}KZ_{eq} \\ -\frac{1}{3}KZ_{eq} & -\frac{2}{3}KZ_{eq} & -\frac{1}{3}KZ_{eq} \\ \frac{2}{3}KZ_{eq} & \frac{1}{3}KZ_{eq} & -\frac{1}{3}KZ_{eq} \end{bmatrix} \end{aligned} \quad (7)$$

$$Z_{eq} = R_{eq} + jX_{eq} \quad (8)$$

The model expresses the feeder-end phase voltages as a function of the primary-side line voltages and phase currents, which are available from monitoring devices.

IV. ACCURATE ARC MODEL

An accurate ARC model is proposed which computes the ARC as the difference between the voltage-driven reinforcement cost for the three-phase imbalanced case and that for the balanced benchmark. The calculations are based on the primary-side measurements of the phase currents and the line

voltages when the yearly maximum phase current occurs. This is consistent with the DNOs' current practice to plan the networks for the maximum demand scenario. The model considers the imbalance in both magnitudes and phase angles. But its practicality is limited because it poses excessive data requirements by demanding phasor measurements for the currents and voltages. Nonetheless, it is the basis for the semi-simplified and fully simplified models.

A. Three-Phase Imbalanced Case

This paper adopts the idea to calculate asset reinforcement costs by translating them to the time horizon [14, 20]. As a result of demand growth, it is assumed that the annual growth rate of a phase current is r . Take phase a as an example. Suppose the number of years for the phase voltage V_{an} to drop to the statutory lower limit is n_a , which is the solution to the following equation:

$$\left| \frac{1}{K} \dot{V}_{AB} + Z_{d11} \dot{I}_A (1+r)^{n_a} + Z_{d12} \dot{I}_B (1+r)^{n_a} \right| = V_{lower} \quad (9)$$

Equation (13) is transformed into

$$(A^2 + B^2)(1+r)^{2n_a} + (2AC + 2BD)(1+r)^{n_a} + (C^2 + D^2 - V_{lower}^2) = 0 \quad (10)$$

where

$$A = R_{d11} I_A \cos \theta_A - X_{d11} I_A \sin \theta_A + R_{d12} I_B \cos \theta_B - X_{d12} I_B \sin \theta_B \quad (11)$$

$$B = X_{d11} I_A \cos \theta_A + R_{d11} I_A \sin \theta_A + R_{d12} I_B \sin \theta_B + X_{d12} I_B \cos \theta_B \quad (12)$$

$$C = \frac{1}{K} V_{AB} \cos \theta_{AB} \quad (13)$$

$$D = \frac{1}{K} V_{AB} \sin \theta_{AB} \quad (14)$$

Similar equations can be derived for the other two phases. The general solution n_ϕ for each phase is given by

$$n_\phi = \frac{\log(-F_\phi - \sqrt{F_\phi^2 - 4E_\phi G_\phi}) - \log E_\phi - \log 2}{\log(1+r)} \quad (15)$$

where $\phi \in \{a, b, c\}$.

$$E_\phi = X_{dm1}^2 I_A^2 + R_{dm1}^2 I_A^2 + R_{dm2}^2 I_B^2 + X_{dm2}^2 I_B^2 + 2I_A I_B (R_{dm1} R_{dm2} + X_{dm1} X_{dm2}) \cos(\theta_A - \theta_B) \quad (16)$$

$$F_\phi = \frac{2}{K} R_{dm1} V_{LL_\phi} I_A \cos(\theta_A - \theta_{LL_\phi}) - \frac{2}{K} X_{dm1} V_{LL_\phi} I_A \sin(\theta_A - \theta_{LL_\phi}) + \frac{2}{K} R_{dm2} V_{LL_\phi} I_B \cos(\theta_B - \theta_{LL_\phi}) - \frac{2}{K} X_{dm2} V_{LL_\phi} I_B \sin(\theta_B - \theta_{LL_\phi}) \quad (17)$$

$$G_\phi = \frac{1}{K^2} V_{LL_\phi}^2 - V_{lower}^2 \quad (18)$$

When $\phi = a$, there are $m = 1$ and $LL_\phi = AB$; when $\phi = b$, there are $m = 2$ and $LL_\phi = BC$; when $\phi = c$, there are $m = 3$ and $LL_\phi = CA$.

The number of years n_{IB} for the phase voltages to drop to the statutory lower limit is determined by the phase of which the voltage first reaches the lower limit.

$$n_{IB} = \min\{n_a, n_b, n_c\} \quad (19)$$

By the end of the n_{IB} th year, the DNO will pay an investment cost IC to tackle the voltage issue, e.g. by deploying a parallel LV transformer [7, 21]. It should be noted that this represents a conventional solution adopted by the DNOs [6, 7, 21]. It is not the least-cost option for tackling the voltage issue, but it is set as the benchmark solution, with which the costs of alternative solutions (e.g. deploying voltage regulators, load shifting, and capacitor banks) can be compared. The present value of the voltage-driven reinforcement cost for the imbalanced case is given by

$$PV_{IB} = \frac{IC}{(1+d)^{n_{IB}}} \quad (20)$$

where d is the discount rate.

B. Three-Phase Balanced Benchmark

A three-phase balanced benchmark needs to be defined for the calculation of ARC. This is to understand what the voltage-driven reinforcement cost would be if three phases were perfectly balanced and that the same three-phase complex power is transmitted as in the imbalanced case.

For the imbalanced case, the three-phase complex power is given by

$$\dot{S} = \dot{V}_{AB} \dot{I}_{AB}^* + \dot{V}_{BC} \dot{I}_{BC}^* + \dot{V}_{CA} \dot{I}_{CA}^* \quad (21)$$

$$\begin{aligned} \dot{S} = & \frac{1}{3} \dot{V}_{AB} \dot{I}_A^* - \frac{1}{3} \dot{V}_{AB} \dot{I}_B^* + \frac{1}{3} \dot{V}_{BC} \dot{I}_A^* \\ & + \frac{2}{3} \dot{V}_{BC} \dot{I}_B^* - \frac{2}{3} \dot{V}_{CA} \dot{I}_A^* - \frac{1}{3} \dot{V}_{CA} \dot{I}_B^* \end{aligned} \quad (22)$$

The three-phase balanced benchmark is a special case of the imbalanced model. There are $I_A = I_B = I_\phi$, $\theta_A - \theta_B = 120^\circ$ and $V_{LL} = V_{AB}$. Let $\phi = \theta_A - \theta_{AB}$. Then $\phi - 120^\circ = \theta_B - \theta_{AB}$. Assume the line voltage magnitude for the balanced benchmark is the arithmetic mean of the line voltages for the imbalanced case.

$$V_{LL} = \frac{1}{3} (V_{AB} + V_{BC} + V_{CA}) \quad (23)$$

The line current magnitude for the balanced case is given by

$$I_{LL} = \frac{P}{3V_{LL} \cos(\phi + 30^\circ)} = \frac{\text{real}(\dot{S})}{3V_{LL} \cos(\phi + 30^\circ)} \quad (24)$$

where $\cos(\phi + 30^\circ)$ is the power factor.

The phase current magnitude is given by

$$I_\phi = \sqrt{3} I_{LL} \quad (25)$$

In this case, the number of years it takes for the voltage to drop to the lower limit is given by

$$n_{\text{balanced}} = \frac{\log(-F - \sqrt{F^2 - 4EG}) - \log E - \log 2}{\log(1+r)} \quad (26)$$

where

$$E = \frac{1}{3} K^2 R_{eq}^2 I_\phi^2 + \frac{1}{3} K^2 X_{eq}^2 I_\phi^2 \quad (27)$$

$$F = -R_{eq} V_{LL} I_\phi \cos \phi + \frac{1}{\sqrt{3}} R_{eq} V_{LL} I_\phi \sin \phi + \frac{1}{\sqrt{3}} X_{eq} V_{LL} I_\phi \cos \phi + X_{eq} V_{LL} I_\phi \sin \phi \quad (28)$$

$$G = \frac{1}{K^2} V_{LL}^2 - V_{lower}^2 \quad (29)$$

The present value of the voltage-driven reinforcement cost for the balanced case is given by

$$PV_B = \frac{IC}{(1+d)^{n_{\text{balanced}}}} \quad (30)$$

Therefore, the ARC is given by

$$ARC = PV_{IB} - PV_B = K_{ARC} \cdot PV_B \quad (31)$$

where coefficient $K_{ARC} = \frac{1}{(1+d)^{n_{IB}} - n_{\text{balanced}}} - 1$.

The coefficient K_{ARC} expresses ARC as a proportion of the present value of the voltage-driven reinforcement cost for the benchmark, i.e. the three-phase balanced case.

V. SEMI-SIMPLIFIED ARC MODEL

The major drawbacks for the accurate ARC model are: 1) phase angle measurements are required for the calculations; and 2) elements E_\emptyset , F_\emptyset , E , and F have over-complicated expressions. The first drawback particularly hinders the applications of the accurate model to the fields. To make the ARC model more practical for field applications and to allow for utility-scale efficient calculations, a semi-simplified ARC model and a fully simplified one are proposed in this section and the next section, respectively.

A semi-simplified ARC model is proposed where the calculations of voltage-driven reinforcement costs for both the three-phase imbalanced case and the balanced case are partially simplified based on the assumption of phase angle balance: $\theta_A - \theta_B = 120^\circ$, $\theta_{AB} - \theta_{BC} = 120^\circ$ and $\theta_{CA} - \theta_{AB} = 120^\circ$. This level of simplification considers the imbalance of magnitudes only. It is highly useful because it removes the requirement for phasor measurements, which are usually not available in distribution networks. In fact, the semi-simplified ARC model is the most accurate option among alternatives in the absence of phasor measurements.

Let $\theta_{AB} = 0$. For the imbalanced case, the time to reinforce n_\emptyset ($\emptyset \in \{a, b, c\}$) and n_{IB} have the same form as given in (15) and (19), respectively. Elements G_\emptyset is unchanged as given in (18). However, elements E_\emptyset and F_\emptyset are simplified as follows:

$$E_a = \frac{1}{9} K^2 (R_{eq}^2 + X_{eq}^2) (I_A^2 + I_B^2 + I_A I_B) \quad (32)$$

$$F_a = -\frac{2}{3} R_{eq} V_{AB} I_A \cos \theta_A + \frac{2}{3} X_{eq} V_{AB} I_A \sin \theta_A + \frac{2}{3} R_{eq} V_{AB} I_B \cos(\theta_A - 120^\circ) - \frac{2}{3} X_{eq} V_{AB} I_B \sin(\theta_A - 120^\circ) \quad (33)$$

$$E_b = \frac{1}{9} K^2 (R_{eq}^2 + X_{eq}^2) (I_A^2 + 4I_B^2 - 2I_A I_B) \quad (34)$$

$$F_b = -\frac{2}{3} R_{eq} V_{BC} I_A \cos(\theta_A + 120^\circ) + \frac{2}{3} X_{eq} V_{BC} I_A \sin(\theta_A + 120^\circ) - \frac{4}{3} R_{eq} V_{BC} I_B \cos \theta_A + \frac{4}{3} X_{eq} V_{BC} I_B \sin \theta_A \quad (35)$$

$$E_c = \frac{1}{9} K^2 (R_{eq}^2 + X_{eq}^2) (4I_A^2 + I_B^2 - 2I_A I_B) \quad (36)$$

$$F_c = \frac{4}{3} R_{eq} V_{CA} I_A \cos(\theta_A - 120^\circ) - \frac{4}{3} X_{eq} V_{CA} I_A \sin(\theta_A - 120^\circ) + \frac{2}{3} R_{eq} V_{CA} I_B \cos(\theta_A + 120^\circ) - \frac{2}{3} X_{eq} V_{CA} I_B \sin(\theta_A + 120^\circ) \quad (37)$$

The present value of the voltage-driven reinforcement cost for the imbalanced case PV_{IB} has the same form as in (20).

For the balanced case, the time to reinforce n_{balanced} , elements E and G , and the present value of the voltage-driven reinforcement cost PV_B have the same form as in (26), (27), (29), and (30). F is given by

$$F = -R_{eq} V_{LL} I_\emptyset \cos \theta_A + \frac{1}{\sqrt{3}} R_{eq} V_{LL} I_\emptyset \sin \theta_A + \frac{1}{\sqrt{3}} X_{eq} V_{LL} I_\emptyset \cos \theta_A + X_{eq} V_{LL} I_\emptyset \sin \theta_A \quad (38)$$

The ARC formula has the same form as in (31).

VI. FULLY SIMPLIFIED ARC MODEL

For LV networks with a high power factor close to unity, the semi-simplified ARC model can be further simplified to allow for fast estimations of the ARCs on spreadsheets. The fully simplified model not only inherits the assumptions of the semi-simplified model but goes further by making the following assumptions: $X_{eq} = 0$, $\theta_{AB} = 0$, $\theta_{BC} = -120^\circ$, $\theta_{CA} = 120^\circ$, $\theta_A = -30^\circ$, and $\theta_B = -150^\circ$. Essentially, the fully simplified model assume i) a purely resistive LV circuit; and ii) a unity power factor, i.e. only real power is considered. However, the highly simplified nature and the limited applicability of the fully simplified ARC model represent a tradeoff: the model is not applicable when the power factor is less than 0.95.

For the imbalanced case, n_\emptyset ($\emptyset \in \{a, b, c\}$), n_{IB} , G_\emptyset and PV_{IB} have the same form as those in (15), (19), (18) and (20), respectively. But elements E_\emptyset and F_\emptyset are significantly simplified compared to the accurate model:

$$E_a = \frac{1}{9} K^2 R_{eq}^2 (I_A^2 + I_B^2 + I_A I_B) \quad (39)$$

$$F_a = -\frac{1}{\sqrt{3}} R_{eq} V_{AB} (I_B + I_A) \quad (40)$$

$$E_b = \frac{1}{9} K^2 R_{eq}^2 (I_A^2 + 4I_B^2 - 2I_A I_B) \quad (41)$$

$$F_b = -\frac{2}{\sqrt{3}} R_{eq} V_{BC} I_B \quad (42)$$

$$E_c = \frac{1}{9} K^2 R_{eq}^2 (4I_A^2 + I_B^2 - 2I_A I_B) \quad (43)$$

$$F_c = -\frac{2}{\sqrt{3}} R_{eq} V_{CA} I_A \quad (44)$$

For the balanced case, n_{balanced} , G , and PV_B have the same form as in (26), (29) and (30), respectively. However, elements E and F are simplified as follows:

$$E = \frac{1}{3} K^2 R_{eq}^2 I_\emptyset^2 \quad (45)$$

$$F = -\frac{2}{\sqrt{3}} R_{eq} V_{LL} I_\emptyset \quad (46)$$

In this model, the above elements E_\emptyset , F_\emptyset , E , and F are simplified to the extent that utility-scale ARC calculations can

be efficiently conducted on spreadsheets.

The ARC formula has the same form as in (31).

VII. LINEARIZATION FOR TWO SPECIAL CASES

Linearization is conducted for two special cases, i.e. the balanced voltages and imbalanced currents case, and the balanced currents and imbalanced voltages case (both ‘voltages’ and ‘currents’ refer to the measurements on the primary-side of the transformer). The linearization provides even simpler calculations than the fully simplified ARC model, allowing for utility-scale ARC calculations to be completed within seconds on spreadsheets.

For the balanced voltages and imbalanced currents case, assume that the magnitude of phase A current is greater than that of phase B current by a percentage of α , i.e. $I_A = (1 + \alpha)I_B$; and that all phase angles are balanced with 120° difference between each other. The linearization is applicable when α is close to zero, corresponding to a slight imbalance in the magnitudes of the currents. ARC can be expressed as a function of α :

$$ARC = f(\alpha) \quad (47)$$

There is

$$f(0) = 0 \quad (48)$$

ARC can be linearized with regard to α through Taylor’s expansion.

$$ARC = M_1\alpha \quad (49)$$

where coefficient M_1 can be regarded as a constant.

M_1 is calculated in the following steps:

i) Suppose $\alpha = 0.5\%$. I_A and I_B are then determined. Based on I_A , I_B and the balanced voltages, the ARC (denoted as $ARC_{0.5\%}$ where the subscript is the α value) can be calculated from the accurate ARC model in Section IV, or the semi-simplified ARC model in Section V, or the fully-simplified ARC model in Section VI.

And ii) calculate $M_1 = \frac{ARC_{0.5\%}}{\alpha} = 200ARC_{0.5\%}$.

Similarly, for the balanced currents and imbalanced voltages case, assume that U_{AB} is greater than U_{BC} in magnitude by a percentage of β , i.e. $U_{AB} = (1 + \beta)U_{BC}$; and that all phase angles are balanced with 120° difference between each other. The linearization is applicable when β is close to zero. ARC is expressed as a function of β :

$$ARC = g(\beta) \quad (50)$$

There is

$$g(0) = 0 \quad (51)$$

ARC can be linearized with regard to β through Taylor’s expansion.

$$ARC = M_2\beta \quad (52)$$

where coefficient M_2 can be regarded as a constant.

M_2 is calculated in a similar way to M_1 . Given a small β , e.g. $\beta = 0.5\%$, the ARC (denoted as $ARC_{\beta=0.5\%}$ when $\beta = 0.5\%$) can be calculated either from the accurate model, or the semi-simplified model, or the fully simplified model. $M_2 = \frac{ARC_{\beta=0.5\%}}{0.5\%} = 200ARC_{\beta=0.5\%}$.

VIII. CASE STUDY

The case study is conducted on a typical LV circuit as a combination of a Dyn11 transformer and a three-phase main feeder, based on the line voltages and phase currents measurements on the primary side. The list of parameters used in the base case are given in Table I.

TABLE I
LIST OF PARAMETERS

Parameter	Value	Parameter	Value
K	11,000/245	Z_f	$0.032+j0.0075 \Omega$
V_{lower}	216V (= 230 × 0.94) *	V_{LL}	11kV
r	2.5%	I_ϕ	12.1244A
d	5.0%	Power factor	0.98
Z_t	$0.012+j0.0106\Omega$	IC	£40,000**

* The UK’s lower voltage limit is -6% from the nominal voltage [22].

** This is the investment cost of a parallel transformer.

The case study investigates the impacts of current magnitude imbalance, voltage magnitude imbalance, power factor, and phase angle imbalance on the ARCs separately. In the first three cases, phase angles are assumed to be balanced, which is a necessary assumption given the absence of phasor measurements in distribution networks.

A. The Impact of Current Imbalance on ARCs

To identify the impact of current imbalance on ARCs, three-phase voltages are assumed to be balanced, of which the magnitude is $V_{LL} = 11kV$. The currents magnitudes for phase A and B are: $I_A = (1 + \alpha)I_\phi$, and $I_B = I_\phi$. The parameter α represents the degree of current magnitude imbalance, and a greater α corresponds to a greater degree of the imbalance.

Due to the absence of phasor measurements, the accurate ARC model is not used in this case. The ARCs are calculated from the semi-simplified model, the fully simplified model, and the linearized model under varying α values. The results are as plotted in Fig. 4.

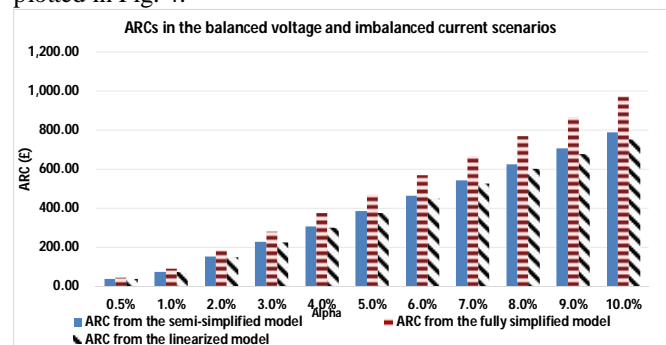

Fig. 4. ARCs in the balanced voltage and imbalanced current scenarios

The results show that the ARCs grow almost linearly with the increase of α . The coefficient M_1 of (49) is calculated from the semi-simplified model. The relative errors are calculated as the relative deviations of the model in question from the semi-simplified model, as presented in Table II.

TABLE II
RELATIVE ERRORS FOR THE IMBALANCED CURRENTS CASES

α	Relative deviation of the fully-simplified model	Relative deviation of the linearization model
0.5%	21.90%	0.00%
1%	21.97%	-0.24%
2%	22.11%	-0.72%
3%	22.25%	-1.20%
4%	22.39%	-1.67%
5%	22.53%	-2.14%
6%	22.66%	-2.60%
7%	22.80%	-3.06%
8%	22.93%	-3.51%
9%	23.06%	-3.96%
10%	23.19%	-4.41%

The linearized model produces results with satisfactory accuracy, where the errors increase from -0.24% to -4.41% with the increase of α . The negative relative errors demonstrate that the ARCs actually grow slightly ‘faster than linear’ with the increase of α , i.e. the ARC is a monotonically increasing, convex but close-to-linear function of α .

The fully simplified model produces higher ARCs than the semi-simplified model, where the errors are much higher than the linearized model, increasing from 21.90% to 23.19% with the increase of α . The major source for this error is identified as the assumption of $X_{eq} = 0$. In this case, $\frac{X_{eq}}{R_{eq}} = 41\%$, where the transformer contributes a major proportion to the equivalent reactance X_{eq} of the LV circuit. The fully simplified model represents a tradeoff between accuracy and efficiency in calculations. On the positive side, the fully simplified model produces rough estimations, enabling utility-scale estimations to be done on spreadsheets.

When $\alpha = 10\%$, the ARC is only about 2.4% of the total voltage-driven investment cost. Therefore, current imbalance alone does not have a significant impact on ARCs.

B. The Impact of Voltage Imbalance on ARCs

To identify the impact of voltage imbalance on ARCs, three-phase currents are assumed to be balanced with the magnitude $I_0 = 12.1244A$. Three-phase voltages are given by $\dot{U}_{AB} = (1 + \beta)U_{LL}\angle 0^\circ$, $\dot{U}_{BC} = U_{LL}\angle -120^\circ$, and $\dot{U}_{CA} = -\dot{U}_{AB} - \dot{U}_{BC}$. The parameter β represents the degree of the voltage magnitude imbalance, and a greater β corresponds to a greater degree of the imbalance. The ARCs are calculated from the semi-simplified model, the fully simplified model, and the linearized model under varying α values. The results are as plotted in Fig. 5.

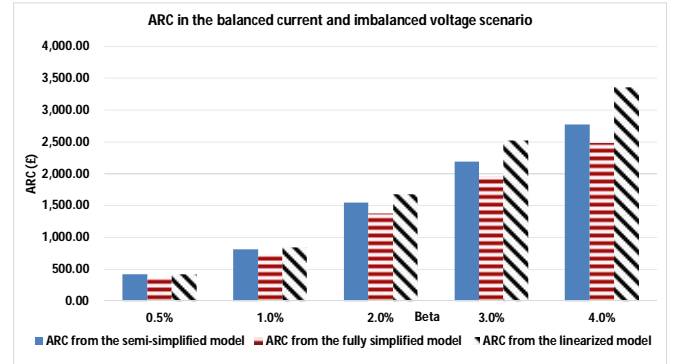

Fig. 5. ARCs in the balanced current and imbalanced voltage scenarios

The results show that ARCs grow almost linearly with the increase of β . Both the fully simplified model and the linearized model demonstrate increasing errors with the increase of imbalance degree β . Unlike in the imbalanced currents case, the linearized model in this case produces higher ARC results than the semi-simplified model, meaning that the ARCs actually grow slower than linear. The relative errors of the fully simplified model from the semi-simplified model is approximately -10.6%, much lower than the errors in the imbalanced currents case. This is because the currents are balanced and fixed in this study – the impact of the assumptions which support the fully simplified model does not grow with the increase of β .

When $\beta = 4\%$, the ARC is already over 6.5% of the total voltage-driven reinforcement cost. This shows that a slight imbalance in the voltage magnitudes has a significant impact on the ARC.

C. The Impact of Power Factor on ARCs

The ARCs for the imbalanced voltages and balanced currents case where $\beta = 1\%$ are calculated under varying power factor values. The results are plotted in Fig. 6.

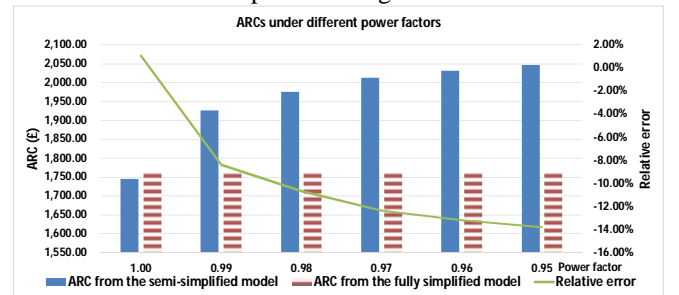

Fig. 6. ARCs under varying power factor values

The results show that the ARCs from the fully simplified model do not change with power factor. This is because the model assumes a unity power factor, where the reactive power is not considered. In contrast, the semi-simplified model considers the growing reactive power with a deteriorating power factor from unity.

The results show a rapidly increasing relative error of the fully simplified model from the semi-simplified model with deteriorating power factor values. For the ideal case where the power factor is 1.0, the error is merely 1.07%. However, a tiny drop of power factor from 1.0 to 0.99 will cause the error to increase from 1.07% to -8.4%, and a 0.95 power factor causes

an error of nearly -14%.

The study proves that the accuracy of the fully simplified model is highly sensitive to power factor. The model would be more accurate when the power factor is close to unity.

D. The Impact of Phase Angle Imbalance on ARCs

Previous studies assumed balanced phase angles in the absence of phasor measurements. In this section, we investigate the impact of phase angle imbalance on the ARCs and present a comparison between the accurate ARC model that considers the phase angle imbalance and the semi-simplified one that ignores such an imbalance. Two cases are defined:

Case 1): the voltages are balanced; the currents have the same magnitude but with imbalanced phase angles, represented by an angle difference δ_I deviating from -120° between \dot{I}_B and \dot{I}_A .

Case 2): the currents are balanced; the voltages have the same magnitude but with imbalanced phase angles, represented by an angle difference δ_V deviating from -120° between \dot{V}_{BC} and \dot{V}_{AB} .

Fig. 7 and 8 present the results for case 1) and 2), respectively.

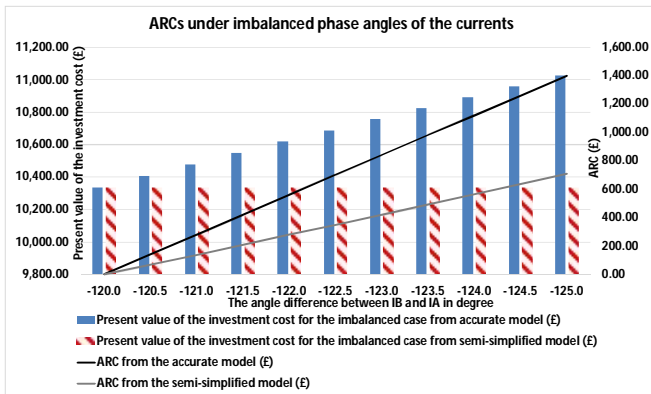

Fig. 7. Results when the currents have imbalanced phase angles

For case 1), the results in Fig. 7 show that the ARCs increase almost linearly with the phase angle difference δ_I . In terms of the present values of the investment costs for the imbalanced case PV_{IB} , the accurate model yields a linearly increasing PV_{IB} with the phase angle difference, whereas the semi-simplified model yields a constant PV_{IB} irrespective of the change of the phase angle difference. This is because the semi-simplified model assumes balanced phase angles with 120° apart from each other. Both the accurate and the semi-simplified models produce the ARCs that are no more than 15% of PV_{IB} given the range of the phase angle difference δ_I from -120° (balanced) to -125° . However, with the increase of the phase angle difference, the ARCs from the accurate model grow almost twice as fast as those from the semi-simplified model, i.e. the slope of the ARC curve from the accurate model is approximately twice as much as that of the ARC curve from the semi-simplified model.

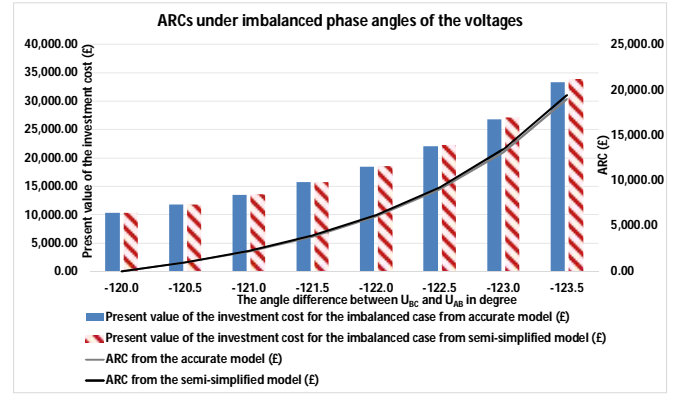

Fig. 8. Results when the voltages have imbalanced phase angles

For case 2), results in Fig. 8 show that the ARC is a monotonically increasing, convex function of the phase angle difference δ_V . So are PV_{IB} from both the accurate and the semi-simplified models. Unlike in case 1), both the accurate and the semi-simplified models produce the ARCs as high as 67% of PV_{IB} when the phase angle difference δ_V is -123.5° . Any further imbalance in phase angles would result in the non-existence of a feasible solution. The semi-simplified model yields almost the same ARC and PV_{IB} results as the accurate model, with the maximum error being less than 3%.

Two conclusions can be drawn from the comparison: 1) voltage angle imbalance has a greater impact on the ARCs than current angle imbalance, given other conditions the same; and 2) the accuracy of the semi-simplified model is much higher in the case of voltage angle imbalance than in the case of current angle imbalance. This suggests the need to monitor the phase angles of the currents for improving the accuracy of the ARC estimation.

IX. CONCLUSIONS

This paper proposes novel ARC models for a typical LV circuit as a combination of a Dyn11 transformer and a main feeder, based on primary-side (11kV) voltage and current measurements. The following conclusions can be drawn from the case study:

- 1) The ARC is a monotonically increasing, convex (concave) but close-to-linear function of the current (voltage) imbalance degree. The linearized models produce satisfactory results for both the imbalanced currents case and the imbalanced voltage case.
- 2) A slight imbalance in the voltage magnitudes causes a significant ARC.
- 3) The imbalance in the current magnitudes compromises the accuracy of the fully simplified ARC model more than that in the voltage magnitudes. An increasing imbalance in the current magnitudes reduces the accuracy of the fully simplified ARC model increasingly, but this is not true for an increasing imbalance in the voltage magnitudes.
- 4) The accuracy of the fully simplified model is highly sensitive to power factor – its accuracy is significantly reduced even with a slight deterioration of power factor from unity.

5) Voltage angle imbalance has a greater impact on the ARCs than current angle imbalance. However, the accuracy of the semi-simplified model is higher in the case of voltage angle imbalance than in the case of current angle imbalance.

The simplifications not only remove the requirement on phasor measurements but also allow for the ARC calculations to be conducted efficiently on a utility scale. This is essential in helping DNOs to fully appraise the voltage-driven cost implications in three phase imbalanced LV networks.

REFERENCES

- [1] J. Zhu, M. Y. Chow, and F. Zhang, "Phase balancing using mixed-integer programming [distribution feeders]," *Power Systems, IEEE Transactions on*, vol. 13, pp. 1487-1492, 1998.
- [2] L. Yun and P. A. Crossley, "Voltage balancing in low-voltage radial feeders using scott transformers," *Generation, Transmission & Distribution, IET*, vol. 8, pp. 1489-1498, 2014.
- [3] N. C. Woolley and J. V. Milanovic, "Statistical Estimation of the Source and Level of Voltage Unbalance in Distribution Networks," *Power Delivery, IEEE Transactions on*, vol. 27, pp. 1450-1460, 2012.
- [4] M. W. Siti, D. V. Nicolae, A. A. Jimoh, and A. Ukil, "Reconfiguration and Load Balancing in the LV and MV Distribution Networks for Optimal Performance," *Power Delivery, IEEE Transactions on*, vol. 22, pp. 2534-2540, 2007.
- [5] Y. Ruifeng and T. K. Saha, "Investigation of Voltage Imbalance Due to Distribution Network Unbalanced Line Configurations and Load Levels," *Power Systems, IEEE Transactions on*, vol. 28, pp. 1829-1838, 2013.
- [6] (2013). *R10-ED1 HV and LV network investment analysis*. Available: http://www.spenergynetworks.co.uk/userfiles/file/201303_A2_4_TNEI_HV_LV_network_investment_analysis.pdf
- [7] Y. Zhang, F. Li, Z. Hu, and G. Shaddick, "Quantification of low voltage network reinforcement costs: A statistical approach," *Power Systems, IEEE Transactions on*, vol. 28, pp. 810-818, 2013.
- [8] A. M. Cossi, R. Romero, and J. Mantovani, "Planning of secondary distribution circuits through evolutionary algorithms," *Power Delivery, IEEE Transactions on*, vol. 20, pp. 205-213, 2005.
- [9] T. Sugita, D. Iioka, Y. Yokomizu, T. Matsumura, N. Hatakeyama, T. Kuriyama, and T. Ootaki, "Low-voltage distribution network planning taking account of power loss cost in genetic algorithms," in *Future Power Systems, 2005 International Conference on*, 2005, pp. 5-10.
- [10] A. M. Cossi, R. Romero, and J. Mantovani, "Planning and Projects of Secondary Electric Power Distribution Systems," *Power Systems, IEEE Transactions on*, vol. 24, pp. 1599-1608, 2009.
- [11] A. Navarro and H. Rudnick, "Large-Scale Distribution Planning Part I: Simultaneous Network and Transformer Optimization," *Power Systems, IEEE Transactions on*, vol. 24, pp. 744-751, 2009.
- [12] I. Ziari, G. Ledwich, A. Ghosh, and G. Platt, "Optimal distribution network reinforcement considering load growth, line loss, and reliability," *Power Systems, IEEE Transactions on*, vol. 28, pp. 587-597, 2013.
- [13] E. Matlotse and F. Li, "Long-run incremental cost pricing for the use of network reactive power compensation devices for systems with different R/X ratios," in *Power & Energy Society General Meeting, 2009. PES '09. IEEE, 2009*, pp. 1-8.
- [14] F. Li and E. Matlotse, "Long-run incremental cost pricing based on nodal voltage spare capacity," in *Power and Energy Society General Meeting - Conversion and Delivery of Electrical Energy in the 21st Century, 2008 IEEE, 2008*, pp. 1-5.
- [15] J. Zhu, G. Bilbro, and M.-Y. Chow, "Phase balancing using simulated annealing," *Power Systems, IEEE Transactions on*, vol. 14, pp. 1508-1513, 1999.
- [16] K. Ma, R. Li, and F. Li, "Quantification of Additional Asset Reinforcement Cost From 3-Phase Imbalance," *IEEE Transactions on Power Systems*, vol. In press, 2015.
- [17] I. Hernando-Gil, "Integrated assessment of quality of supply in future electricity networks," PhD thesis, School of Engineering, University of Edinburgh, 2014.
- [18] (2012). *Understanding Vector Group of Transformer (1)*. Available: <http://electrical-engineering-portal.com/understanding-vector-group-transformer-1>
- [19] W. H. Kersting, *Distribution System Modeling and Analysis*, 3rd ed.: CRC Press, 2012.

- [20] F. Li, "Long-Run Marginal Cost Pricing Based on Network Spare Capacity," *Power Systems, IEEE Transactions on*, vol. 22, pp. 885-886, 2007.
- [21] E. Lakervi and E. J. Holmes, *Electricity Distribution Network Design*. London, UK: The Institution of Engineering and Technology, 2003.
- [22] (2005). *Electrical Supply Tolerances and Electrical Appliance Safety*. Available: https://www.gov.uk/government/uploads/system/uploads/attachment_data/file/293405/05-1410-electrical-supply-tolerances-and-appliance-safety.pdf

BIOGRAPHIES

Kang Ma received the B.Eng. degree from Tsinghua University, Beijing, China, and his Ph.D. degree in Electrical Engineering from the University of Manchester, U.K. He is now working as a research associate at the University of Bath. His research interest include low voltage network planning and operation, especially the integration of low carbon technologies into low voltage networks.

He worked as an R&D engineer at China Electric Power Research Institute (Beijing) from 2011 to 2014, during which time he developed the algorithm and the core software module for distribution network planning platform.

Furong Li (SM'09) was born in Shannxi province, China. She received the B.Eng. degree in electrical engineering from Hohai University, Nanjing, China, in 1990 and the Ph.D. degree from Liverpool John Moores University, Liverpool, U.K., in 1997. She is a Professor in the Power and Energy Systems Group, University of Bath, U.K. Her major research interest is in the area of power system planning and power system economics.

Raj Aggarwal attained his degrees of BEng and PhD from the University of Liverpool in 1970 and 1973 respectively. He joined University of Bath in September 1973. As a professor at University of Bath, he has extensive experience in power system planning, operation, control and protection at all voltage levels, including transmission, distribution and very low voltage domestic.