

**THE EARLY DEVELOPMENTAL HISTORY OF CONCRETE BLOCK
IN AMERICA
A THESIS
SUBMITTED TO THE GRADUATE SCHOOL
IN PARTIAL FULFILLMENT OF THE REQUIREMENTS FOR THE DEGREE
MASTER OF SCIENCE IN HISTORIC PRESERVATION**

**BY
JAMES P. HALL**

**CHAired BY ASSOCIATE PROFESSOR DUNCAN C. CAMPBELL, MSHP
BALL STATE UNIVERSITY
MUNCIE, INDIANA
APRIL 2009**

THE DEVELOPMENTAL HISTORY OF CONCRETE BLOCK IN AMERICA

A THESIS

SUBMITTED TO THE GRADUATE SCHOOL

IN PARTIAL FULFILLMENT OF THE REQUIREMENTS

For the degree

MASTER OF SCIENCE IN HISTORIC PRESERVATION

By

JAMES P. HALL

Committee Approval:

_____	_____
Committee Chairman – Duncan Campbell, MSHP	Date
_____	_____
Committee Member – Francis Parker, Ph. D.	Date
_____	_____
Committee Member – Susan Lankford, MSHP	Date
_____	_____

Departmental Approval:

_____	_____
Department of Architecture – Mahesh Senagala	Date

Graduate Office Check:

_____	_____
Dean of the Graduate School – Robert Morris, Ph. D.	Date

Table of Contents

Acknowledgments	4
Abstract	5
List of Figures	6
List of Concrete Block Related Patents	8
Introduction	10
Concrete: Primer	13
Concrete: A Brief History	17
Concrete Block: An Early History	19
Portland Cement	32
The Commercialization of Concrete Block	37
Concrete Block On The World Stage: The 1904 Louisiana Purchase Expo	54
Conclusion	65
Work Cited	70
Appendix	73

ACKNOWLEDGMENTS

I would first and foremost like to thank my fiancé and soon to be wife, Jenica Duval, for all the support she has given me over these last two years. Without her encouragement, understanding, and love I would have not accomplished this thesis or degree.

I would like to extend the deepest gratitude to my chair, Duncan Campbell, for his insightful dialogue and revisions throughout the process. His understanding and encouragement has not gone unnoticed. I would also like to sincerely thank Francis Parker, a committee member, for all his help and assistance during the process of writing this paper and during my time here at Ball State. I know for a fact that without his presence I would have never succeeded. Also, I must extend much gratitude towards Susan Lankford, a committee member, for her invaluable assistance throughout this whole process. Without her guidance, my time here would have been much more difficult.

Last but not least, I would like to thank all of my friends and family who encouraged and believed that I could do it. Many thanks go to my fellow preservation students who encouraged me along the way.

Abstract

Thesis: The Early Developmental History of Concrete Block in America

Student: James P. Hall

Degree: Master of Science in Historic Preservation

College: Architecture and Planning

Date: May, 2009

Pages: 144

This thesis outlines the early developmental history of concrete block in America with special attention being placed on the years leading up to the St. Louis Louisiana Purchase Exposition of 1904. In general, the history of concrete block in contemporary building material histories begins with the innovations in block machinery that took place at the turn of the 20th century. However, the history of concrete block begins much earlier than these innovations.

Harmon S. Palmer invented the first commercially successful concrete block machine in 1900, but there were many reasons why concrete block became widely used during the first half of the 20th century. The establishments of a domestic Portland cement industry, the innovations in concrete block machinery, and the marketing and promotion of concrete and concrete block at the 1904 St. Louis Louisiana Purchase Exposition, are all major reasons why concrete block began to be widely used in America.

List of Figures

Figure:

Figure 1: George A. Ward House, Staten Island, N. Y.,	24
Figure 2: Foster & Messinger Building Block Patent, 1855.	27
Figure 3: T. J. Lowry concrete block molding box	31
Figure 4: An example of a Frederick Ransome Rotary Kiln	35
Figure 5: H. S. Palmer's first concrete block machine	38
Figure 6: H. S. Palmer's First cast iron concrete block machine	39
Figure 7: H. S. Palmer machine, closed	41
Figure 8: The Normandin side-mount machine	42
Figure 9: H. S. Palmer machine, open	42
Figure 10: A face-down concrete block machine	43
Figure 11: A face-down machine	43
Figure 13: Two-piece concrete block wall system	44
Figure 14: A mechanical press machine	46

Figure 15: Concrete block home built with panel face block	47
Figure 16: Tooled-face cast iron mold for decorating concrete block	48
Figure 17: Rock-face mold and rock-face block	48
Figure 18: Colored concrete block (red)	49
Figure 19: A Winget concrete block machine, closed	50
Figure 20: A Winget concrete block machine, open	50
Figure 21: A Hayden concrete block machine	51
Figure 22: A Dykema concrete block molding box.	52
Figure 23: A Dykema concrete block manufacturing plant	53
Figure 24: Interior view of Portland Cement Building at the 1904 St. Louis Louisiana Exposition.	56

Appendix

List of Concrete Block and Concrete Block Machinery Patents

Pg.

- 75** **Patent 1:** Ambrose Foster & E. A. Messinger, *Building Block*, Patent No. 12,264. Jan. 16, 1855.
- 78** **Patent 2:** Thomas B. Rhodes, *Improvement in Building Blocks*, Patent No. 149,678. April 14, 1874.
- 82** **Patent 3:** T. Cook, *Machine for Manufacturing Blocks of Artificial Stone*, U. S. Patent No. 161,866. April 3, 1875.
- 87** **Patent 4:** W. H. Smith, *Machine for the Manufacture of Artificial Stone*, U. S. Patent No. 177, 578. May 16, 1876.
- 89** **Patent 5:**J. C. Sellers, *Apparatus for Molding Concrete and Artificial Stone*, U. S. Patent No. 244,322. July 12, 1881.
- 93** **Patent 6:**H. S. Palmer, *Machine for Molding Building Blocks*, U. S. Patent No. 375,377. Dec. 27, 1887.
- 95** **Patent 7:** H. S. Palmer, *Building Blocks*, U. S. Patent No.384,541. June 12, 1888.
- 98** **Patent 8:** J. Winkler, *Stamping Machine for Molding Artificial Stone*, U. S. Patent No. 409,542. Aug. 20, 1889.
- 101** **Patent 9:** H. S. Palmer, *Concrete Wall for Buildings*, U. S. Patent No. 674,874. May 28, 1901.

- 106 Patent 10:** N. F. Palmer, *Machine for Molding Artificial Stone*, U. S. Patent No. 694,985. Mar. 11, 1902.
- 110 Patent 11:** H. S. Palmer, *Machine for Molding Hollow Concrete Building Blocks*, U. S. Patent No. 731,323. June 16, 1903.
- 120 Patent 12:** H. S. Palmer, *Artificial Building Blocks*, U. S. Patent No. 36,772. Feb. 3, 1904.
- 123 Patent 13:** H. S. Palmer, *Hollow Building Block*, U. S. Patent No. 800,674. Oct. 3, 1905.
- 125 Patent 14:** F. E. Kidder, *Building Block and Wall*, U. S. Patent No. 793,591. June 27, 1905.
- 128 Patent 15:** H. S. Palmer, *Machine for Making Concrete Blocks*, U. S. Patent No. 828,767. Aug. 14, 1906.
- 142 Patent 16:** I. E. Yarnell, *Concrete Building Block Machine*, U. S. Patent No. 822,333. June 5, 1906.

Introduction

Many important factors were involved in the innovation and evolution of concrete block in America, and too often many of these factors have been overlooked in contemporary architectural histories. Harmon S. Palmer invented the first successful commercial machine used to make concrete block in 1900, and Palmer's invention is important in understanding the initial commercial successes. However, the story does not begin with Palmer, because the introduction of concrete block as a building material predates his invention by well over a half century. As a direct result the early history of concrete block has been overshadowed by the innovations that took place during the first decade of the 20th century.

Palmer's invention had little to do with the widespread commercial successes of concrete block, because numerous concrete block manufacturers established themselves during the same period as Palmer. A wide variety of machines were patented at the turn of the century that had little or no resemblance to his. The marketing ingenuity of the Portland cement industry and other concrete subsidiaries had more to do with the success of concrete block than Palmer's invention.

Concrete block began to be mass produced as a direct result in the increase in the domestic Portland cement industry. The emergence of a domestic Portland cement industry coincides with the first commercially produced block machine. Portland cement was cheaper than natural cement and the increase in domestic production made available a more economical concrete product. The growth of the Portland cement industry was an impetus for the growth of the concrete block industry.

As the Portland cement industry was gaining momentum in America and concrete block machinery was evolving, these two industries benefitted from an international platform, the St. Louis Louisiana Purchase Exposition of 1904. The Expo was the defining moment in America when concrete and concrete block gained an international audience. To date, little attention is placed in contemporary building material histories on how important the 1904 Expo was in promoting the use of concrete and concrete block in America. The Expo was responsible for a significant increase in the awareness of concrete block as a potential building material.

One of the most important influences the Expo had on concrete and concrete block was the role it played in its promotion and marketability. The 1904 Exposition was the first time the Portland cement industry in America came together and worked as one unit to promote its material. A multitude of independent Portland cement companies pooled resources to erect a building at the Exposition.¹ This initial consolidation continued for decades as Portland cement companies promoted the use of concrete and concrete block.

¹ American Society of Testing Materials, *Proceedings of the Eighth Annual Meeting*, Vol. V, (Philadelphia: American Society of Testing Materials, 1905), 396.

The 1904 Exposition also played an integral part in establishing scientific testing of concrete and concrete block. The Exposition building erected by the Portland cement industries also served as a testing laboratory, and after the Expo, the testing of concrete continued in Forrest Park, the site of the Fair.² This testing was financially supported by the United States government, and this marks the first time a federal agency was involved in a comprehensive assessment of concrete and its capabilities.³

Many contemporary sources do not detail in depth the early history of concrete block and the early commercial successes of concrete block machinery. By studying early publications related to concrete block it becomes evident how complex the industry was at the turn of 20th century.

The domestic manufacture of Portland cement, the innovations in concrete block making technology, and the role concrete played at the 1904 St. Louis Louisiana Purchase Exposition are just a few reasons why concrete block originally gained acceptance in America, and these claims will be argued using numerous primary sources which will in turn outline the early history of concrete block in America.

² Ibid.

³ Richard L. Humphrey, *Organization, Equipment, and Operations of the Structural-Materials Testing Laboratories at St. Louis, MO.*, U. S. Geological Survey (Washington D. C.: Government Printing Office, 1908), 8.

Concrete: A Primer

In order to discuss concrete and concrete block, it is important to understand the material composition of concrete. Concrete is a highly complicated material. The chemical composition of modern concrete closely resembles the composition of natural limestone. For this reason, concrete could be viewed as an artificial stone. To put it abstractly, concrete is the byproduct of the man-made reversal of nature; it is a man-made reconstitution of minerals into stone. Concrete is created by combining three main ingredients: aggregates, cement, and water.

The aggregate and its application in concrete can vary widely from culture to culture, region to region and has changed over the epochs of history. Generally, aggregates consist of sand or gravel, and can even be as large as rocks or stones. However, experience has proven that the smaller the aggregate the stronger and more durable the concrete will be. Geological differences result in different types of aggregates. The sand or gravel of Europe differs greatly from the sand and gravel found in Midwest America. Some aggregates have proven to be more successful in producing stronger cements than others. Two types of aggregates are generally utilized within

concrete, fine or coarse aggregate. Fine aggregate is typically screened sand or stone. The screening process frees the aggregate of all useless matter. However, fine aggregate should not be confused with fine sand. Fine sand should be avoided because fine sand is more porous than coarse sand when water is introduced due to the more granules present in fine sand.⁴

The other common aggregate utilized in concrete is coarse aggregate. Coarse aggregate is generally gravel, broken stone, or cinders. Gravel is generally superior to broken stone because of its smooth round pebbles as opposed to jagged broken stone.⁵ The smoothness allows for better compaction during tamping.⁶

The binder in concrete that holds the aggregates together is referred to as cement. Cement is not a finished structural product, but is only an ingredient within concrete. Cements can be broken down into two groups; natural and manmade.

Natural cement is created by heating limestone at a very high temperature and thus forcing out the carbon within the stone.⁷ After the stone has been heated the byproduct is crushed into a powder. The limestone used in natural cement production must contain between 13 to 35% clay material in which 10 to 22% is silica.⁸ The finished product is a fine powder mixture referred to as lime. This powdery mixture is

⁴ Harmon H. Rice, *Concrete-Block Manufacture Process and Machines* (New York: John Wiley & Sons, 1906), 10.

⁵ Lewis, Myron H. and Albert H. Chandler, *Popular Hand Book for cement and Concrete Users* (New York: The Norman W. Henley Pub. Co., 1911), 40.

⁶ Ibid.

⁷ Frederick W. Taylor and Sanford E. Thompson, *A Treatise on Concrete Plain and Reinforced, Materials, Construction, and Design of concrete and Reinforced Concrete* (New York: John Wiley & Sons, 1916), 43.

⁸ Edwin C. Eckel, *The Material and Manufacture of Portland Cement*, Geological Survey of Alabama, Bulletin No. 8 (Montgomery, Alabama: The Brown Printing Company, 1904), 9.

then mixed with an aggregate and water which in turn can be used in mortars, plasters, and concretes. Natural cements were the most widely produced cements used in America during the 19th century. It was very common to name the cement after the locality where it was produced; examples include Rosendale cement and Louisville cement.⁹

Common lime, or quick lime, is natural cement that has been utilized within mortars and plasters for centuries. Lime based mortars and cements are made possible by the presence of the calcium carbonate that is found in limestone. Calcium carbonate contains three main ingredients: calcium, carbon, and oxygen.¹⁰ When limestone is heated, a chemical reaction forces carbon and oxygen out of the stone and the byproduct is a highly reactive material known as quicklime, or calcium oxide. When quicklime is treated with water, or hydrated, a chemical reaction takes place that produces heat and the result is referred to as hydrated lime.

Another type of natural cement is Puzzolan. Puzzolan was first utilized by the Greeks and later perfected by the Romans. Puzzolan was the dominant cement used within the great engineering feats of the Roman Empire. Puzzolan consists of lime mixed with volcanic ash. Because volcanic ash has already been exposed to extreme temperatures during volcanic eruptions, no further heating is needed, unlike the pulverization utilized in lime production.

A modern version of Puzzolan cement is called slag cement. The chemical composition of slag cement is basically the same as traditional Puzzolan, but instead of

⁹ Ibid.

¹⁰ F. Wolfgang Tegethoff, *Calcium Carbonate; From the Cretaceous Period into the 21st Century* (Birhauser, 2001), 2.

volcanic ash, blast-furnace slag is substituted. Blast furnace slag is the byproduct of iron production.

During the 19th century, experiments with the chemical composition of mortars produced the first man made cement, Portland cement:

Portland cement is produced by burning a finely ground artificial mixture containing essentially lime, silica, alumina, and iron oxide, in certain definite proportions. Usually this combination is made by mixing limestone or marl with clay or shale, in which case about three times as much of the lime carbonate should be present in the mixture as of the clayey materials. The burning takes place at a high temperature, approaching 3,000° F., and must, therefore, be carried on in kilns of special design and lining. During the burning, combination of the lime with silica, alumina, and iron oxide takes place. The product of the burning is a semi-fused mass called clinker, consisting of silicates, aluminates, and ferrites of lime in certain definite proportions. This clinker must be finely ground. After grinding the powder, Portland cement, will set under water.¹¹

¹¹ Eckel, 10.

Concrete: A Brief History

Concrete has been utilized by many cultures and has been invented and reinvented for over a millennia. The exact recipes of ancient concretes have been lost. It could be argued that concretes of ancient Greece and Rome were equal if not superior to pre-Portland cement concretes due to their longevity and their hydraulic qualities. The complete history of concrete is yet to be written, because of modern man's limited archeological knowledge of pre-Roman civilizations. To date, ancient Rome is credited with perfecting a form of concrete, but the ancient Egyptians and ancient Greeks both utilized lime-based mortars and plasters.

The Romans were one of the first cultures to use concrete on a wide scale as a building material. The Romans utilized a form of concrete called Puzzolan in the construction of the extensive aqueduct projects starting in the first century B.C. Puzzolan was formed into u-shaped trenches to carry water over long distances, and some of these trenches still exist today as a testament to the durability of Roman cement and the ingenuity of Roman engineers. The Pantheon may be the first grand structure that utilized concrete, or Puzzolan; it was constructed in the first century A.D. The Pantheon

is regarded as the largest un-reinforced concrete dome in the world and is also thought to be one of the oldest structures in continuous use. The Pantheon used Pozzolana in the wide-reaching dome, which is credited as being one of the most impressive indoor open spaces of the Roman Empire.¹²

However, the expertise of Roman engineers was lost for well over a millennium, and it was not until the Renaissance that Europe was able to duplicate a material that even came close to the strength and durability of Pozzolana. It was not until the 17th and 18th centuries in England that concrete was used again on a wide scale as a building material.

¹² Frank Harvey Eno, *The Use of Hydraulic Cement*, No. 2, 4th series (Springfield, Ohio: Springfield Publishing Co., 1904), 18.

Concrete Block: An Early History

Presently, most concrete historians credit Harmon S. Palmer as the inventor of the modern concrete block. These assertions are oversimplifications because they limit this important invention to only one individual, when it was a result of an evolutionary process spanning decades. These oversights also overlook the fact that the concrete block was invented well before post-industrialization and prior to the building boom that took place in America during the second half of the 19th century. This is a major oversight, because the block form was a groundbreaking achievement. Its realization was not created overnight or by one lone individual. The block took centuries if not millennium to come to fruition and its importance should not be diminished due to preconceived notions of its cheapness and coldness. Concrete is “artificial stone,” and in block form should be relegated as one of the most important building innovations of the last several centuries.

It is debatable as to what culture first utilized concrete block as a building material. It is generally agreed upon by most academics that concrete construction was first utilized on a large scale by Roman engineers. However, there is evidence and

ongoing research at the time of this writing that suggests that an Egyptian form of concrete predates the Roman usage by well over a millennium; this usage was in the form of a block.¹³

Some evidence suggests that the earliest use of concrete block was initiated by the ancient Egyptians in the construction of the Great Pyramids. Although it is a highly controversial argument, contemporary claims have been made by academics that the ancient Egyptians made use of a form of concrete within some of the building blocks of the pyramids, mainly the upper portions where the handling and manipulability of large cut stone blocks was almost impossible. The claim is that many upper story blocks were actually molded in place utilizing wooded molds.¹⁴

The leading proponent of this argument is Joseph Davidovits, a French chemical engineer who coined the term geopolymer, and one of the leading experts on Geopolymer Chemistry. Davidovits claims geopolymers are alkali aluminosilicate-based binders and if mixed with a high concentrated limestone aggregate could form a compound that is almost identical to natural stone.¹⁵ Beginning in the 1980's, Davidovits argued that many of the blocks within the pyramids were constructed using a high concentration of limestone concrete, or geopolymer. The Davidovits' theory asserts that the ancient Egyptians had very advanced knowledge of alchemy, and that it is more plausible that they chemically constructed some blocks than chiseled and moved them vast distances as currently believed by many historians. The theory states that the Egyptians created a re-

¹³ Joseph Davidovits, *They Built the Pyramids* (Institute Geopolymere, 2008), 31.

¹⁴ *Ibid.*, 12.

¹⁵ The Research Group of Dr. Michel Barsom, *Of Geopolymers, Pyramids, and Homes, A White Paper* (Philadelphia: Drexel University, 2006), 1-2.

agglomerated stone by utilizing naturally broken up limestone mixed with chemicals to produce stone that looks, feels, and has the strength of limestone found in the region.¹⁶

Davidovits' theory has been cautiously accepted if not totally disregarded by the archeological and Egyptological community due to decades of preconceived notions and academic assertions. However, it should be noted that the idea of concrete block pyramids has precedence as an early American concrete publication attests in 1909:

Of the antiquity of the use of manufactured blocks there seems to be no doubt. It is called a modern industry, but it has been proved that the Egyptians used porous lava that contained hydraulic properties and the basic element necessary in the making of cement similar to our Portland of today. The sarcophagus in which they placed their dead was manufactured stone. It has been pretty definitely decided that at least the upper portions of the Egyptian pyramids were formed in the same manner and the massive blocks of stone that have baffled the past ages by the mystery of their transportation to such elevations probably were borne to their destination by pailful. As a further proof that these blocks were of man's formation breakages in some of them reveal small pieces of wood embedded in the mass.¹⁷

Davidovits's theory aside, it is hard to determine an exact date for when man first molded concrete into a block or brick form. Historians agree upon the fact that the Romans did mold concrete within the extensive aqueduct works throughout the Roman

¹⁶ Ibid.

¹⁷ William A. Radford, *Cement Houses and How to Build Them* (Chicago: Radford Architectural Company, 1909), 5.

Empire, but there is no evidence that they molded concrete into blocks that resembled cut stone. The notion of concrete molded into blocks is an important innovation in the use of concrete construction. The molded block form is important because it is easy to manufacture, transport, and is durable and long lasting.

One of the earliest applications in the modern era of the block form was established in England by William Ranger in 1832. William Ranger of Brighton, England, took out a patent for artificial stone less than ten years after the invention of Portland cement.

William Ranger molded his blocks by utilizing wooden molds that were held together by wood trenails, or pegs, and iron clamps.¹⁸ It was stated that:

a number of the molds being laid out in a line, the mixing boards are placed near them, in which the sifted quick lime powder and the proper proportion of gravel and sand are mixed with boiling water, with all exceptions: and the mixture is thrown immediately into one of the moulds, in which it is continually rammed until the mould is quite full, where a smooth surface is made upon the top of the artificial stone afterward by a plasterer.¹⁹

Ranger's first attempt at building something out of his concrete block was noted in an 1835 English architectural journal:

¹⁸ C. W. Pasley, *Observations on Limes, Calcareous Cements, Mortars, Stuccos and Concrete, and Puzzolanas, Natural and Artificial* (London: John Weale Architectural Library, 1847), 19.

¹⁹ *Ibid.*, 20.

The first work executed in this material (concrete block) was a wall surrounding the garden of Mr. Peel of Kemp Town. The ashlar stones (2ft. long and 9 1/2 in. by 8 in.) were formed on the spot, and became in a few hours, sufficiently hard to commence setting. The mortar used in laying was formed of the same materials, and the whole become as it were, one entire mass of concrete; having the precise appearance and the durability of Portland stone, though the proprietor did not incur above a third of the cost.²⁰

It is interesting that this very early testimonial of concrete block promotes its importance relative to its similar appearance and cost to real Portland limestone. The mention of Portland limestone is interesting because of Aspdin's discovery of Portland cement less than a decade earlier. Aspdin named his cement Portland after its relative appearance to the limestone of the Portland region of England. It is not known if Ranger was aware and utilizing Aspdin's discovery or if these two men just happen to be concurrently innovative, but it is very interesting that the invention of Portland cement and the comparisons of Ranger's blocks to Portland limestone are similar. Portland cement and concrete block would continue to have an important relationship well into the 20th century. Portland cement would be the catalyst for the concrete boom in America during the turn of the 20th century.

The first documented concrete block residence in America was constructed shortly after Ranger's invention. It is not known if the utilization of concrete block

²⁰ J. C. Loudon, *The Architectural Magazine, and Journal of Improvements in the Architectural, Building, and Furnishing, and in the Various Arts and Trades Connected Therewith*, Vol. II, Art. VI (1835), 62.

coincidentally happened in America or if it was transplanted via diffusion. The house was constructed on Staten Island, New York, by George A. Ward, Esq. who was a well-to-do, well-traveled merchant in 1837. (Fig. 1) Unfortunately this structure no longer remains and it is up for debate as to the actual construction technique utilized. In a 1904 publication, the author states, after visiting the structure that:

The oldest concrete house built in the United States is of monolithic concrete. It was built on Staten Island, N. Y. in 1837 of natural cement concrete. Although badly weather worn and dilapidated this house still stands and was inhabited by one or two families when the writer visited it in 1902. It must be remembered that this house was built of the imperfect natural cement made in those early years and the aggregate used was not carefully selected, but portions were compounded of brickbat, irregular and rather large sized broken stone.²¹



Figure 1: Picture of the George A. Ward House, or “The Cement House,” built 1837. Picture taken in 1902. Frank Harvey Eno, *The Use of Hydraulic Cement*, 4th series, No. 2. (Springfield, Ohio: Springfield Publishing Co., 1904), 74.

²¹ Frank Harvey Eno, *The Use of Hydraulic Cement*, No.2, 4th series (Springfield, Ohio: Springfield Publishing Co., 1904), 74.

This author claimed that the Ward house was constructed of monolithic concrete but a slightly earlier 1900 source states the house was, “generally known as the, ‘Cement House,’ and the walls are of solid blocks of cement or composition. These blocks were cast in moulds, and on being exposed to the sun, soon became as hard as the ordinary red sandstone.”²²

Because George A. Ward was a well-traveled merchant and spent much time in Europe, including England, it is possible he came across the techniques that William Ranger was experimenting with in concrete block construction. A blurry picture of the “Cement House” in Frank Eno’s *The Use of Hydraulic Cement*, shows the house to be a castellated structure with one turret on each corner of the dwelling. Although blocks are not visible in the picture it is most likely built of concrete masonry because monolithic concrete had not been tried and tested yet. It is also possible that the author who visited the property in 1902 mistook the structure for monolithic construction when in actuality it was constructed of an early version of concrete block. The description of William Ranger’s invention, previously described, attests that the mortar used in laying the block was of the same material as the block itself, which resulted in the finish product looking like one mass. The one mass could have been mistaken for monolithic construction. It is also possible the walls were plastered over thus concealing the block form. This is most

²² Ira k. Morris, *Morris’s Memorial History of Staten Island*, Vol. II (West New Brighton, New York, 1900), 171.

likely the construction technique utilized in Ward's Cement House because monolithic or grout wall construction was not utilized until the second half of the 19th century.²³

In 1850, Joseph Gibbs, an English engineer, took out a patent for the construction of solid concrete walls. The walls would be constructed by utilizing timber forms that could be removed after curing. Gibbs stated:

When it is thought advisable to dispense with the lattices and to make the wall without any part of it being composed of wood, then in such case, blocks of the size of the stone of which the wall would be composed under ordinary circumstances are to be cast, only these blocks are to be hollow, having only sides and ends, the sides and ends being made about two Inches thick. After every course of these blocks have been built, the hollows must be filled with concrete like that before described. The blocks being made to break joints with each other, and being filled with cementious matter, the wall will become one mass of solid artificial stone, so there will be no necessity to put mortar between the blocks to bed them.²⁴

Although the intention of Gibbs was not to construct hollow concrete block walls, his invention was the precursor to the hollow block system. Many people who

²³ Orson S. Fowler, *A Home For All, or the Gravel Wall and Octagon Mode of Building*, (New York: Dover Pub., Inc.1855), 19. Orson Fowler experimented with grout wall construction starting in the 1850's. Fowler claimed Mr. Goodrich of Milton, Wisconsin was the discoverer of this building method. Fowler advocated the use of a gravel or grout wall type of construction for Octagon houses.

²⁴ Harmon H. Rice, *The Manufacture of concrete Blocks and Their Use in Building Construction* (New York: The Engineering New Publishing Co., 906), 33.

constructed block walls with Gibbs system skipped the process of filling in the hollow cores.²⁵

In 1855, an American patent was applied for by Ambrose Foster and John Messinger, both of Wisconsin, for a concrete mixture and mold process of manufacturing

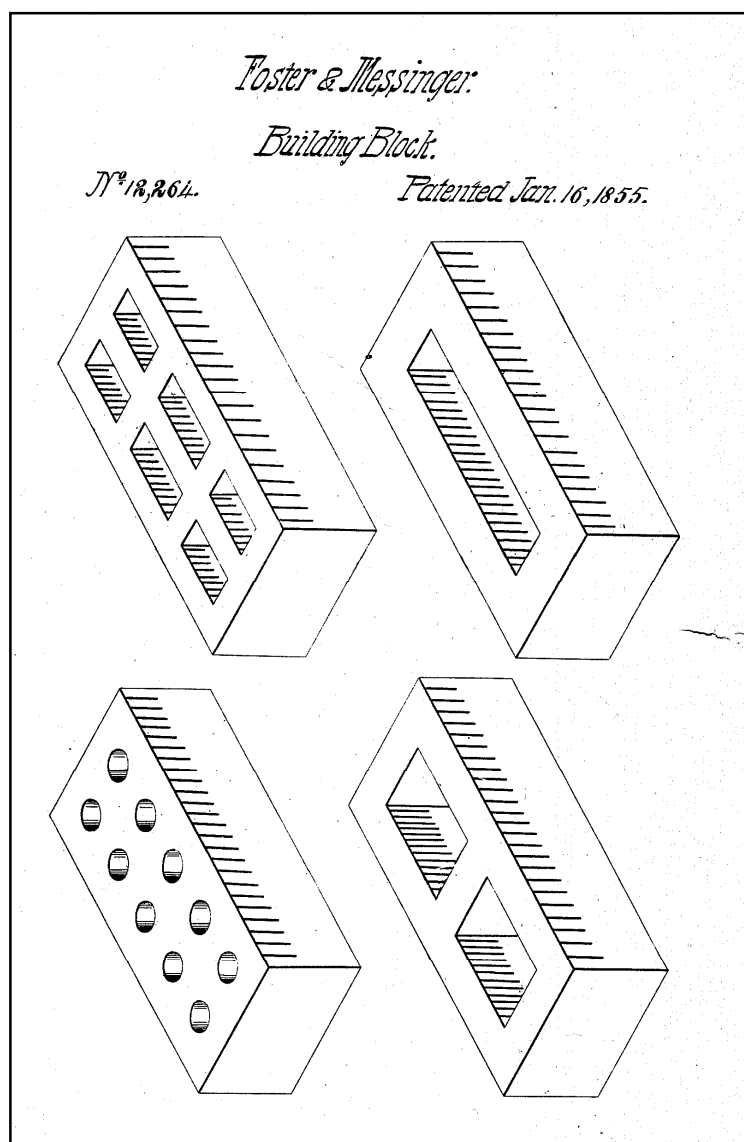

concrete blocks. (Fig.

2) Although Messinger was no longer alive, he is credited on the patent.

The patent for the *Improved Building Block, or Artificial Granite* was filed and accepted on January 16, 1855.²⁶ (See

Appendix, p. 75)

Figure 2: Foster and Messinger's patent for the *Improved Building Block, or Artificial Granite*, U. S. Patent Office, Jan. 16, 1855. Notice the hollow core options presented in the patent drawing.

²⁵ Ibid.

²⁶ Ambrose Foster, "*Improved Building Blocks, or Artificial Granite*," US Patent 12264. 16 Jan. 1855.

Foster's and Messinger's patent specified the process was nothing more than mixing common sand, or gravel, and lime. By mixing eleven bushels of sand or gravel to one bushel of unslaked lime, an artificial stone could be produced.²⁷ This mixture of ingredients then had to be consolidated by pressure, which was accomplished by a mechanical press. The most important aspect of Foster's and Messinger's system is the hollow core element introduced within the block. Prior to the hollow core innovation, concrete blocks were solid and void of any air chambers. The hollow core was introduced within Foster's design in order to assist and speed up the curing process. According to the patent documents they ignored the fact that these hollow core elements also limited the amount of material necessary in their production. They also ignored the fact that the reduction of material made the blocks much lighter and easier assemble.

One 20th century author has stated about Foster's system, "The blocks were solid, made entirely by hand in awkward wooden molds, oversized, very heavy, and exceedingly hard to handle."²⁸ This author's assertions have perpetuated decades of misinformation. Foster's blocks were not solid. The blocks may have been awkward and cumbersome, but they were hollow, and the importance of this fact cannot be understated. The hollow cores assisted in the curing process, lightened the weight of each block, and also helped in insulating exterior walls. Foster and messenger may have not been aware

²⁷ Charles P. Dwyer, *The Economic cottage Builder: On, Cottages for Men of Small Means* (Buffalo: Wanzer, McKim & Co., 1856), 100.

²⁸ Joseph Bell, *From The Carriage Age...To The Space Age...The Birth and Growth of the Concrete Masonry Industry* (Arlington, Va.: National Concrete Masonry Association, 1969), 1.

of the importance of their innovation, but it would set a precedent in concrete block production that has carried over to the present day.

In an 1856 publication explaining his patent, Foster goes into detail on how the mechanical elements of concrete block production are limited and in their infancy. Foster explained that a company in New Hampshire was on the eve of perfecting the mechanical process of manufacturing block:

M. & J. H. Buck & Co. have perfected a press, which, I think will work admirably, and with two of which, driven by small engine, or other power, and with 10 or 12 hands, 5000 Blocks may be mixed, molded and piled away per day. I think, in most cases, it will be found more economical to work them by steam or horse power – one horse being sufficient to drive two presses. The power applied continuously feeds the moulds, presses the Block, and raises it from the mould, holding it a sufficient time to be removed. The only manual labor required is the mixing and filling the hopper, taking off the Blocks, and piling them away.²⁹

This arrangement was highly sophisticated for antebellum America and was a precursor to the early 20th century industrialization of the concrete block industry. It was not until the second decade of the 1900s that concrete block was manufactured on such a mass scale as the M & J. H. Buck process described. In all reality, the mechanization that Foster describes was never realized.

²⁹ Ambrose Foster's Patent, " *Improved Building Blocks or Artificial Granite*," No. 75, Nassau St. New York, 1856, 7.

Foster's patent also addressed the opportunity for ornamentation. Foster explained, "Ornamental devices too, may be molded upon the block, which could not be formed upon any kind of brick or block, that required burning, without increasing the expense beyond what would be justified by the value of the brick when finished."³⁰ Although Foster did not give great detail about how to ornament blocks, his conceptualization of the opportunity to do so anticipates later developments.

Foster & Messinger were the inventors of the modern version of the concrete block. Their contributions are understated and should be reevaluated. Their molding process utilized pressure and mechanization; and their awareness of concrete's ornamental capabilities all suggest that Foster & Messinger should be credited with inventing the modern concrete block masonry unit. They have been overlooked and misrepresented in building material histories. Unfortunately most architectural and building material historians ignore this period of discovery and jump ahead to post industrial manufacture.

After the Civil War, further advancements in molding block were realized. In 1868, Thomas J. Lowry patented an apparatus for molding block. (Fig.3) This molding box was an interesting innovation because a) it had the hollow core element built into it, b) it was constructed with handles and a wheel for ease in moving, c) it incorporated interchangeable dove tail elements into the mold that would allow for an interlocking component in the constructions of walls.

³⁰ Ambrose Foster, U.S. Patent 12264.

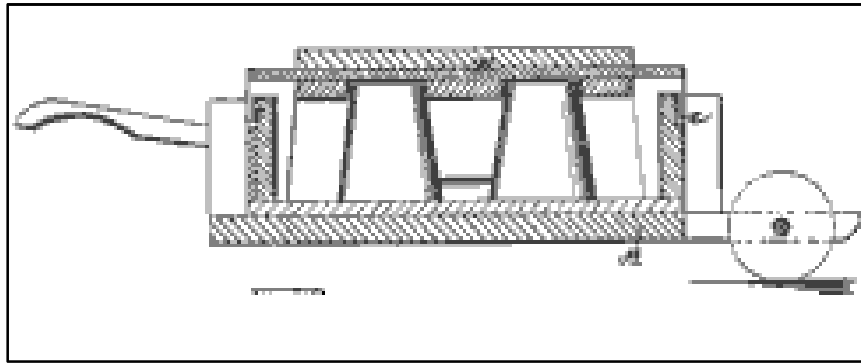

Figure 3: A cross section view of T. J. Lowry concrete block molding box. Harmon Howard Rice, *The Manufacture of concrete Blocks and Their Use in Building Construction* (New York: The Engineering New Publishing Co., 1906), 32.

The previously described concrete block systems are an overview of the many innovations made during the 19th century. The innovations achieved by Ranger, Foster, and others set the stage for the inventors of Late Victorian America. Pamela Simpson in *Quick, Cheap, and Easy; Imitative Architectural Materials, 1870-1930* states:

While concrete is an ancient building material, concrete block is essentially a product of the twentieth century. None of the nineteenth century patents, led to any widespread production of concrete block. They all were isolated experiments that produced a few buildings and gave impetus for the idea of block, but not to its practical mass production.³¹

³¹ Pamela H. Simpson, *Cheap, Quick, & Easy: Imitative Architectural Materials, 1870-1930* (Knoxville: The University of Tennessee Press, 1999), 11.

Simpson argues that the mass production of concrete block was due to innovations in machinery. However, it was not the innovations in machinery that allowed concrete block to be produced on a wide scale; it was the mass production of Portland cement that allowed for eventual machinery to even be profitable.

Portland Cement

One of the most important innovations in the use of concrete was the introduction of man-made cement known as Portland cement. Portland cement was invented by Joseph Aspdin of Leeds England in 1824. Aspdin named the compound Portland because he felt it resembled the oolitic limestone of Portland, England.³²

During the last decade of the 19th century, Portland cement displaced natural cement in America as the leading binding agent utilized in the manufacture of concrete. The first attempt at producing Portland cement in America was in 1872 in Kalamazoo, Michigan, but the plant was unsuccessful and had little to do with future development of the material in other parts of the country.³³

Prior to domestic manufacturing, all Portland cement used in America was imported from Europe, especially England. This kept cement prices high, and as a result cement was not perceived to be economically practical in construction. However, as

³² Edwin Eckel, *Portland Cement Materials and Industry In the United States*, Department of the Interior, U. S. Geological Survey, Bulletin 522 (Washington D. C.: Government Printing Office, 1913), 24.

³³ *Ibid.*, 27.

domestic manufacture increased, the prices of Portland cements were driven down and concrete's potential as a building material was realized.

In 1890, only sixteen domestic Portland cement manufacturers were known in the United States.³⁴ Over the next decade, American production increased so much that by 1902 there were 65 plants producing Portland cement in America; this number grew steadily over the next decade.³⁵ Two main factors contributed to the increase in domestic Portland cement manufacturing: the perfection of the rotary kiln and timber shortages at the turn of the 20th century.³⁶

Kilns had been utilized in the production of Portland cement from the very beginning. Kilns are and were used to produce Portland cement by burning a mixture of pulverized materials containing lime, silica, and alumina.³⁷ What results from burning this mixture is a product called a clinker and this clinker is then crushed into a fine powdery mixture called Portland cement.³⁸

³⁴ *Transactions of the Society of Civil Engineers*, Vol. LIV (New York: International Engineering Congress, 1905), 426.

³⁵ *Ibid.*

³⁶ William A. Radford, *Cement Houses and How to Build Them* (Chicago: Radford Architectural Company, 1909), 3

³⁷ Edwin C. Eckel, *The Material and Manufacture of Portland Cement*, *Geological Survey of Alabama, Bulletin No. 8* (Montgomery, Alabama The Brown Printing Company, 1904), 43.

³⁸ *Ibid.*, 43.

The rotary kiln was invented in England by Frederick Ransome in 1885.³⁹ Ransome's invention consisted of cylinders 25 ft. long and 5 ft. in diameter.⁴⁰ (Fig. 4) The cylinders would be propped up on rollers and these rollers would in turn rotate the cylinders.⁴¹ The American industry took Ransome's concept and perfected and commercialized it. In 1893 the American Portland cement industry used rotary kilns within 25.2% of all Portland cement manufacture, and by 1900 the rotary kiln was used in 81.5% of all Portland cement manufacture.⁴² The rotary kiln proved to be very

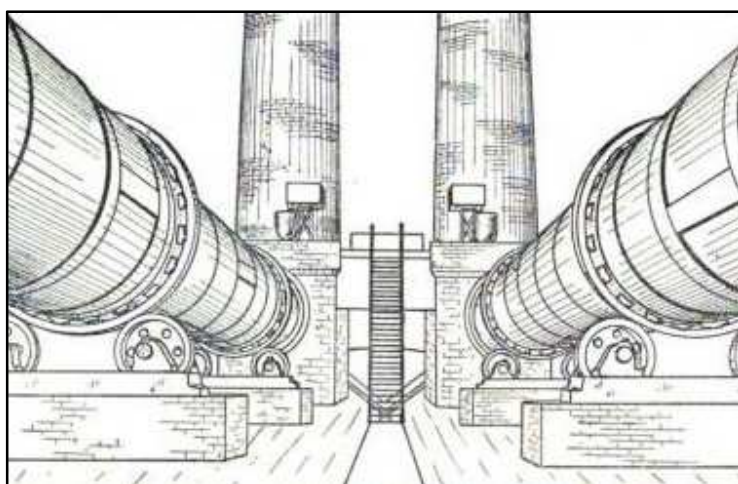

Figure 4: An example of a rotary kiln which was invented by Frederick Ransom in 1885. The rotary kiln effectively produced large quantities of Portland cement. James A. Audley, *Silica and the Silicates* (New York: D. Van Nostram, 1921), 148.

successful in manufacturing large quantities of Portland cement and this increase at the turn of the century is a testament to its practicality.

Another important factor in the increase in the production of Portland cement was the lack of available lumber at the turn of the 20th century.⁴³ The

mass production of Portland cement coupled with the shortages of timber created an

³⁹ *Transactions of the Society of Civil Engineers*, Vol. LIV (New York: International Engineering Congress, 1905), 428.

⁴⁰ James A. Audley, *Silica and the Silicates* (New York: D. Van Nostram, 1921), 147.

⁴¹ *Ibid.*

⁴² *Transactions of the Society of Civil Engineers*, Vol. LIV (New York: International Engineering Congress, 1905), 428.

⁴³ Radford, *Cement Houses*, 3.

opportune situation for experiments with new building technologies. Concrete block is an example of one such building material.

The Commercialization of Concrete Block

Foster & Messinger may have been the first individuals to conceptualize the modern block form, and its mass production, but Foster & Messinger never gained much success and notoriety for their invention. During the second half of the 19th century, many inventors, both in America and Europe, tackled the idea of creating a practical and simple machine for molding concrete blocks on a mass scale. Some machines were overly elaborate and could not be practically used or moved. Some required engines or highly elaborate belt systems. As the 19th century came to a close, numerous concrete block machines entered the market.

During the 1880s, an economical molding machine for building blocks was closer to being realized. In 1887, Harmon S. Palmer filed for a U. S. patent for a *Machine for Molding Building Blocks*. Palmer's first patent comprised of a table with a molding unit in the center.(Fig. 5)(See **Appendix, p. 93**) The table and molding unit were constructed of wood, and the sides of the mold could be retracted in order to remove the concrete block. The introduction of the table is important in understanding Palmer's eventual successful innovations.

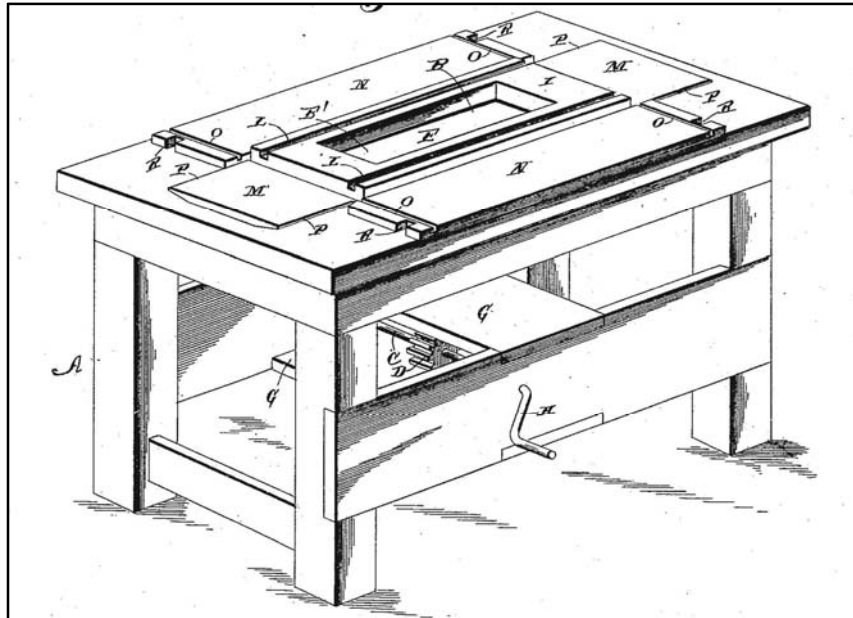

Figure 5: H. S. Palmer's original concrete block machine.

By 1900, Palmer evolved his original table system into a four legged cast iron unit that had a removable core and collapsible sides. (Fig. 6) The removable core and collapsible sides are what make Palmer's invention important, because this ingenious adaptation allowed the maker to remove “green” blocks from the machine without damaging them. (See **Appendix, p. 106, 110, 128**) The use of cast iron is also important, because of the constant and repetitive motion of manufacturing blocks and the moist nature of creating concrete, wood proved to be an inferior molding material.



Figure 6: An example of H. S. Palmer's first cast iron concrete block machine. Eno, 75.

In 1902, Palmer started the Hollow Building Block Company, claiming that he was the inventor of the original hollow concrete block system.⁴⁴ Over the next decade, many variations of cast iron concrete block machines flooded the U. S. patent office in Washington D. C.; Palmer attempted to take to court anyone whose machine or block form resembled his. An ad in a 1904 engineering journal warned:

WANTED—We want the name of every party selling, buying or using any HOLLOW CONCRETE BUILDING BLOCK MACHINES, as well as the location of every building erected with HOLLOW CONCRETE BUILDING BLOCKS without our license, and for first information we will pay a reward. "We have six years in which to begin action."⁴⁵

⁴⁴ *Municipal Engineering, Index*, Vol. XXVI, Jan. – June, (Indianapolis: Municipal Engineering Co., 1904), 480.

⁴⁵ *Ibid.*

Palmer was not successful in establishing his claims because he failed to prove he invented the hollow concrete block. As already stated, the hollow concrete block had precedent in the Foster and Messinger system.

In the case of *Clark vs. The Harmon S. Palmer Hollow Concrete Bldg. Block Co.* it was decided:

The Palmer design patent No. 36,806, for a design for artificial building blocks, showing the upper portion of the block having a rock face and the lower part smooth, Is void for anticipation and lack of Invention; It being shown without contradiction that houses still standing were built, prior to the application for the patent, of alternate layers of rock-face and smooth-face stone, presenting substantially the same appearance to the eye as a building of stone made after the design of the patent⁴⁶

Also, Palmer failed to prove that he was the sole originator of the concrete block machine, because a wide variety of machines flooded the patent office shortly after Palmer's 1900 patent. Although similarities existed among some of these machines there were distinct differences among them. Some of these differences included how the concrete was loaded into the machine, the consistency of the concrete used, where the face plate was located on the machine, and ultimately the type of block produced.⁴⁷

⁴⁶ *The Federal Reporter, Cases Argued and Determined in the Circuit Courts of Appeals and Circuit and District Courts of the United States*, Feb. – March, 1907 (St. Paul: West Pub. Co., 1907), 1001.

⁴⁷ Jerome Cocharan, *A Treatise on the Inspection of Concrete Construction* (Myron C. Clark Pub. Co. 1913), 527.

At the turn of the century three types of machines were common; upright, facedown, and mechanical presses. Palmer's machine is a prime example of an upright or side-mount machine. (Fig. 7 and Fig. 8) Within the side-mount machine:

The sides and ends of the machine swing out and down upon hinges. The hollow places in each stone are formed by metal wedges or cones raised into place, through the base plate by means of a cog and ratchet attachment. The side plates can be readily changed so as to substitute smooth, quarry faced, or ornamental facing for the stone desired. The concrete is tamped into the machine upon thin iron base plates, so that as soon as the block, which is made of rather dry concrete, is finished, the sides are let down, the hollow centers lowered and the block is lifted out on this base plate, and allowed to remain upon it until firmly set.⁴⁸ (Fig. 9)



Figure 7: An H. S. Palmer machine in the closed position. The Palmer machine is an example of a side mount machine. Homer A. Reid, *Concrete and Reinforced Concrete*, The Myron C. Clark Pub. Co., New York, 1908, 869.

⁴⁸ Eno, 75.

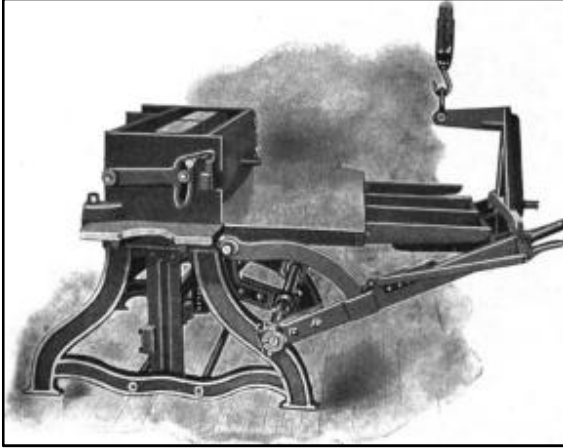

Figure 8: The Normandin Machine at left is an example of a side mount machine, Eno, 239.

The facedown machine was similar to the upright machine, but the major difference being that the mold, or face plate, was located at the bottom of the box instead of the side.(Fig. 10, Fig. 11 and Fig 12) A 1906 publication described this manufacturing process in the following way:



Figure 9:An H. S. Palmer machine in the open position. Homer A. Reid, *Concrete and Reinforced Concrete*, The Myron C. Clark Pub. Co., New York, 1908, 870.

Fine facing matter varying from 1:1 to 1:3 mixture of cement and fine sand, granite screenings or marble dust is deposited and thoroughly tamped, after which the leaner mixture comprised in the body of the block is deposited and tamped in the usual manner, except that the cores, which it will be noted enter and withdraw laterally, are not inserted until the lower half of the block has been

tamped in place. In most machines of the this type the mold is so arranged that when the block is ready for delivery the mold may be turned to an upright

position and the block released either on a wooden pallet or on an iron bottom plate.⁴⁹



Figure 10: An example of a face-down machine of unknown manufacturer. The machine is closed and ready to be opened in order to deposit the block. Reid, 870.

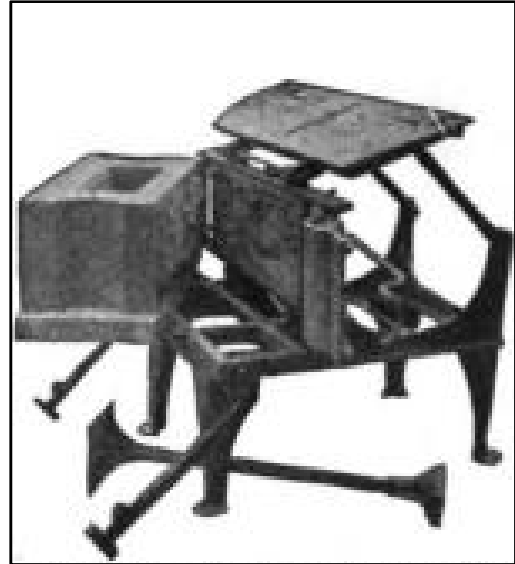

Figure 11: A face-down machine open and ready for the concrete block to be removed. Reid, 870.

The face down machine had the advantage of allowing a different face mixture to be placed in the machine prior the addition of the concrete body mixture.⁵⁰ The facing mixture could consist of a higher Portland cement concentration, a waterproofing chemical, or colored concrete.

⁴⁹Harmon H. Rice, *Concrete-Block Manufacture Process and Machines* (New York: John Wiley & Sons, 1906), 70.

⁵⁰Homer A. Reid, *Concrete and Reinforced Concrete* (New York: The Myron C. Clark Pub. Co., 1908), 869.

The mechanical press method was yet another process utilized in making block and it was generally used in constructing blocks of the two-piece wall system.(Fig. 13)The two-piece wall system was built by staggering blocks to construct an inner and outer wall. These blocks were typically “T” shaped. The two-piece wall system never had much

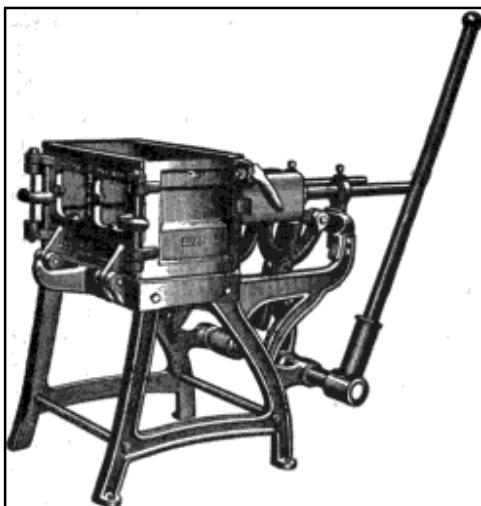

Figure 12: An example of a face-down machine, manufacturer unknown. Radford, *Cement and How to Use It*, 153.

commercial success because of the large size of the machines and the process of manufacture was more complicated. However, it should be noted that the concrete block wall built from the

two-piece system had many advantages. One of these advantages was the presence of the hollow void between the inner and outer walls.

Figure 13: An example of a two-piece wall system. Two-piece wall block was typically built by mechanical concrete block machines. This block design was manufactured by the American Hydraulic Stone Co., Rice, 37.



This void was beneficial for two main reasons: it was advantageous in insulating structures, and provided a vapor barrier. A 1906 publication detailed how a mechanical machine (Fig. 14) worked:

It will be noted that the pressure is applied by means of upright hand-levers, which, by lowering either to the right or to the left, bring into action an arrangement of compound toggles which exert upon the movable bed of the press a pressure of 60,000 pounds. The molds are filled at their respective ends of the track, the medium-wet mixture of one part cement, three of sand, and four of gravel or broken stone being shoveled into the mold and raked off level. The pressing-plate of the particular design required is then put in place on top of the mold, and the mold, which is hung on trolleys having grooved wheels fitting the track, is then run into the press and the pressure made. From three to four seconds is required in this operation. As the pressure is relieved, the mold is withdrawn and two hooks thrown over the pressing-plate to hold it in place, while the mold is inverted and run to the end of the track. The releasing-stand is then raised to engage the pressing-plate, the hooks loosened, and the block lowered (face down), resting on the plate by which it was pressed. The process is very rapid, expert men producing unfaced blocks in twenty seconds and faced blocks in thirty.⁵¹

⁵¹ Rice, *Concrete-Block Manufacture*, 70.

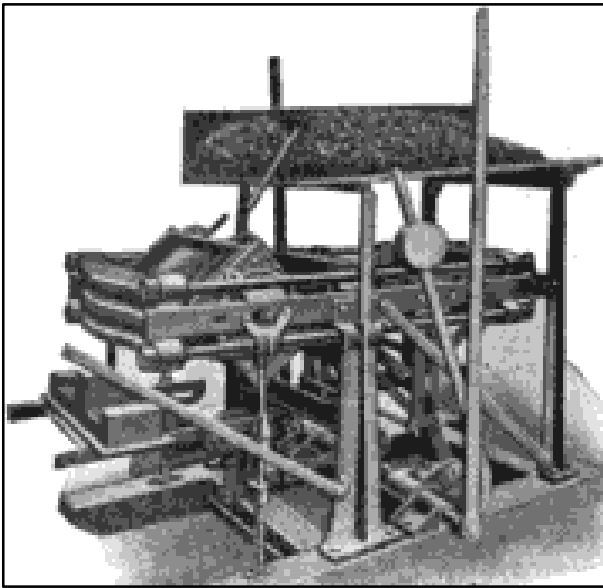

Figure 14: An example of a mechanical press machine manufactured by the American Hydraulic Stone Co. located in Denver, Co. Concrete was deposited into a molding box. The hydraulic lever at the right of the picture was employed to consolidate the concrete by means of mechanical pressure. Reid, 872.

One company that perfected the two-piece wall system was the American Hydraulic Stone Company out of Denver, Colorado, but the company never perfected a machine that could be easily transported from job site to job site which eventually led to its impracticality in the market place.

As with other block machines various molds could be used to face the block with different types of patterns and ornamental designs. Molds, or face plates, were constructed of cast iron and could be used over and over again or interchanged to face the block with the design desired. Some examples of face plates that could be utilized with the American Hydraulic Stone Co. machine included plain-face, paneled-face, tooled-face, rock-face, and pebble-face. (Fig. 15, Fig. 16, and Fig. 17)

Blocks could also come in a variety of colors from brown, grey, black, and red with red being the most common. (Fig. 18) However, colored blocks were not very



Figure 15: Concrete block home built with an American Hydraulic Stone Co. machine, c. 1905-1906. The home was built with panel-face block. Marengo, IL. Photo taken by James Hall.

common because of the additional chemicals needed in their

fabrication. Some of the chemicals needed in coloring block included:⁵²



Figure 16: The picture to the left is a cast iron tool-face mold manufactured by the American Hydraulic Stone Co. Photo by James Hall

⁵² Radford, *Cement Houses and How to Build Them*, 38.

- Black = Peroxide of magnese
- Blue = 5 Lbs ultramarine blue, 1lbs. pulverized alum



Figure 17: The picture on the left is an example of a cast iron rock-face mold manufactured by the American Hydraulic Stone Co. It was utilized to make block similar to the concrete block in the picture on the right. Photo by James Hall

- Red = Oxide of iron or Pompeian red. These chemicals were then mixed with the cement prior to the cement being mixed with the sand or aggregate.⁵³



Figure 18: An example of red concrete block. Red concrete block was manufactured by mixing oxide of iron with the cement. This mixing was done prior to the cement being mixed with aggregates and water. Photo by James Hall.

Palmer should be credited with innovations to machinery for block production, but what hurt Palmer in the long run were his claims for inventing the hollow concrete block and wall system when its invention predated his by several decades. By 1905, numerous concrete machines flooded the market, and they were willing to fight for their

⁵³ Ibid.

legitimacy. Following is just an overview of some of the concrete block manufacturers that gained success shortly following the turn of the 20th century.

The Winget Machine

The Winget Machine was first manufactured in Columbus, OH during the first decade of

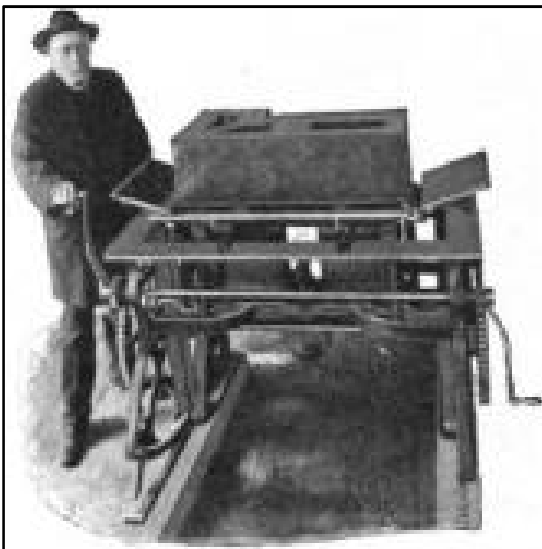

Figure 19:
An example of a Winget Machine prior to being filled with concrete and tamped. Eno, 240.

the 20th century. (Fig. 19 and 20) The Winget machine was constructed of cast iron and had adjustable sides.⁵⁴ The adjustable sides allowed the block maker to face the block with a richer mortar of about $\frac{1}{2}$ to $\frac{3}{4}$ in.

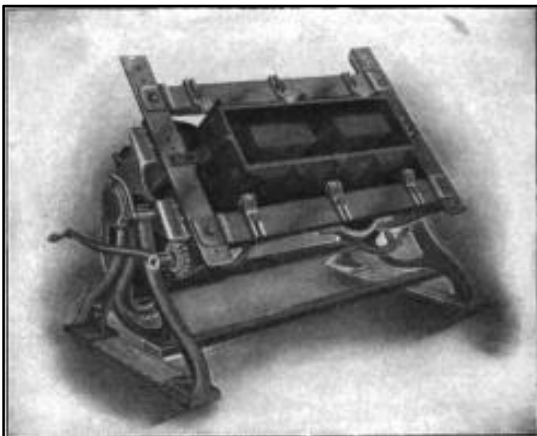

Figure 20: An example of a Winget machine ready for block removal. Eno, 239.

The availability of a different facing material provided strength to the face of the block and also allowed the introduction

⁵⁴ Eno, 239.

of a coloring agent.⁵⁵ The normal size of a Winget block was 9 in. by 10 in. by 32 in. The Winget machine is an example of a side-mount machine.

Hayden Concrete Block Machine

The Hayden machine was also manufactured in Columbus, Ohio and was a face-down machine similar to the Palmer system.⁵⁶ A Hayden block was 8 in. to 16 in. thick and 8 in. to 32 in. long.⁵⁷

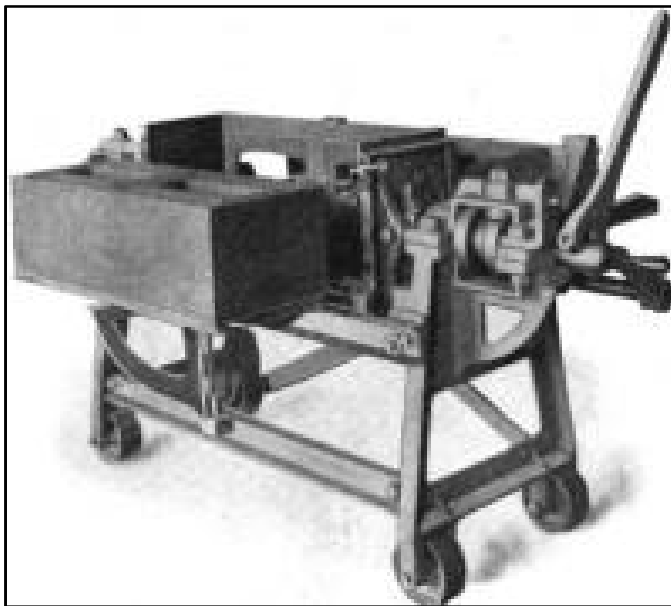

Figure 21: A Hayden concrete block machine depositing a block. The Hayden is an example of a face-down machine. Eno, 245.

⁵⁵ Ibid., 239.

⁵⁶ Ibid., 245.

⁵⁷ Ibid.

Dykema Machine Co.

The Dykema machine was one of the more simple machines for molding concrete block.(Fig. 22) The Dykema molding system consisted of a box constructed of sheet steel with a double interior core element.⁵⁸The box had interior walls that could be manipulated to adjust the size of the block.⁵⁹ A disadvantage of the Dykema system was that you needed a multitude of boxes in order to produce a significant number of blocks.

(Fig. 23)

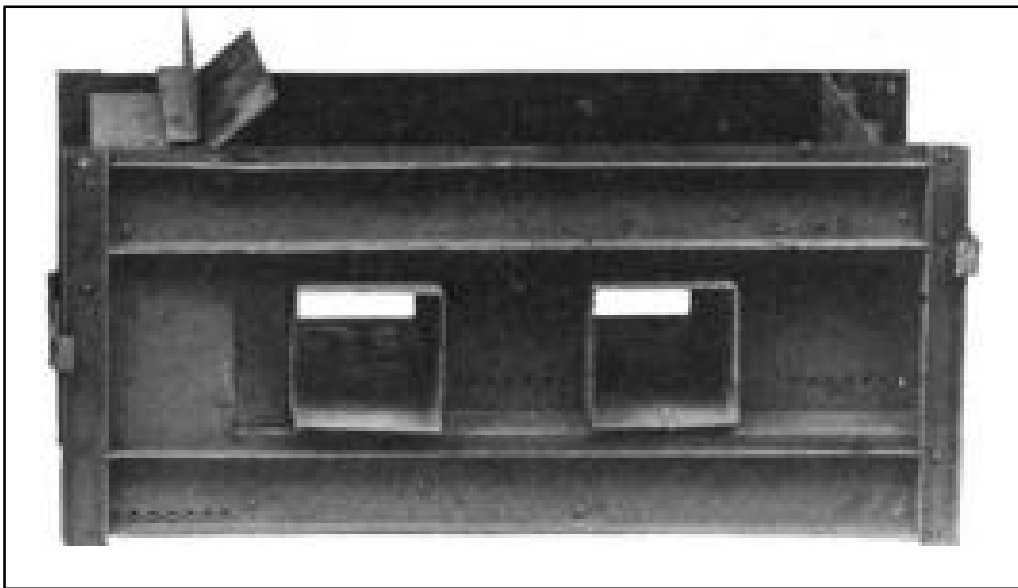

Figure 22: Dykema Block Machine, left was a simple sheet metal box with movable inner walls and interior hollow core elements. Eno, 241.

⁵⁸ Eno, 240.

⁵⁹ Ibid.

Although there were some similarities between different block machines, they all had patentable differences that Palmer could never contend with. Simple differences in machinery and in the finished product resulted in the failure in Palmer's ultimate case. For this reason, Palmer should not be credited with being the sole originator of the commercial concrete block machine.

Figure 23: A manufacturing plant where numerous Dykema machines were lined up and filled with concrete. Notice this system necessitated the use of a horse. Eno, 243.



Concrete Block on the World Stage: The 1904 Louisiana Purchase Expo (St. Louis)

Although concrete block had a long history prior to the turn of the 20th century, it was not until the 1904 Louisiana Purchase Exposition in St. Louis that concrete and concrete block gained a wide audience from the building trades industry and average citizens. The St. Louis Exposition is important in understanding the early development of concrete block for three main reasons. First, the Exposition consolidated a fragmented Portland cement and concrete block industry. Second, the Expo was integral in establishing comprehensive testing for concrete and concrete block, which led to government assistance. Third, the Expo acted as a springboard for the promotion of concrete block to the average citizen.

Prior to the 1904 Louisiana Purchase Exposition, the American Portland cement industry consisted of numerous independent cement manufacturers that competed for dominance of the market. The Expo helped to consolidate the many independent Portland cement manufacturers. At the 1893 Columbian Exposition in Chicago, just eleven years prior, the concrete industry had little presence, but between 1893 and 1904,

the Portland cement industry in American grew at an enormous rate. By 1905, the Portland cement industry in America had outgrown the production of both natural cement and the importation of Portland cement. As a testament to this growth, the Portland cement industry constructed a reinforced concrete building to house their exhibits. (Fig. 24) The intentions of these exhibits were purely for the promotion of Portland cement as a building material and did not promote any one manufacturer over another.⁶⁰ Forty cement manufacturers participated in this exhibit without one brand taking center stage.⁶¹

The Portland cement exhibit housed:

- A collection of the raw materials from which Portland cement is manufactured, together with samples of this material taken in various stages of manufacture, to the finished product.
- A collection of the various sands, gravels, cinders, broken stone and metal used in concrete, together with photographs and models of structures built of concrete in all parts of the world.
- A library of books and files of the various technical journals devoted to cement, mortar and concrete.

⁶⁰ American Society, *Eighth Annual Meeting*, 396.

⁶¹ Ibid.



Figure 24: The interior of the of the Portland cement exhibit housed in the Portland cement building at the 1904 St. Louis Louisiana Exposition. American Society of Testing Materials: *Proceedings of the Eighth Annual Meeting*, Vol. II, 1905, 391.

- A completely equipped model testing laboratory.
- A collection of machines for mixing and molding concrete
- A collection showing the many ways in which Portland cement is used.⁶²

The 1904 exhibit literally brought the major players within the concrete industry under one roof. These satellite industries realized that the promotion of Portland cement and its benefits would be advantageous to all. As a testament to the importance the Expo played in strengthening the industry, Portland cement production increased significantly the following year. By 1905, the usage of Portland cement increased by 36 % from the year previous and natural cement was down 8.5% in 1905 from 1904.⁶³ 1905 was the first year exports of Portland cement were greater than Portland cement imports.⁶⁴

As a result of the 1904 exhibit, concrete and concrete block manufacturing organizations began to be established. One of the first organizations to be established out of the St. Louis Expo was the National Association of Cement Users. During the

⁶² *American Society, Eighth Meeting*., 391.

⁶³ *Ibid.*, 64.

⁶⁴ Richard P. Rothwell, *The Mineral Industry, Its Statistics, Technology and Trade During 1905*, (New York: Engineering and Mining Journal, 1906), 65.

International Engineering Congress held at the Expo between October 3rd and 8th, an informal meeting was set up to discuss the complexities of the current concrete building boom taking place in the country with specific attention placed on concrete block and its manufacture. At this time, the industry lacked an authority in charge of overseeing the integrity of concrete or any of its building methods. Representatives from the many concrete block manufacturers from around the country met to discuss their ever-evolving industry. As a result of this congress, many concrete block manufacturers felt a necessity to consolidate into an association that would set standards and meet regularly to keep up to date about current practices.

The first meeting the following year evolved into the Convention of the National Association of Cement Users. This first meeting was held in Indianapolis, Indiana on January 17-19, 1905. Its original agenda was tailored toward the concrete block industry, but eventually became an association of all concrete workers. By 1913, this organization would become known as the American Concrete Institute.⁶⁵

Another important element to come out of the 1904 Exposition was the implementation of scientific testing with regard to the structural capabilities of concrete and concrete block. The American Society of Testing and Materials, along with the American Society of Civil Engineers, played a role in evaluating the integrity of various methods of producing concrete and the various methods of manufacturing concrete block.

⁶⁵ National Research Council, *Scientific and Technical Societies and Institutions of the United States and Canada*, 4th Ed., No. 106 (Washington D. C., 1942) 39.

The American Society of Testing and Materials established a concrete laboratory, called the Model Testing Laboratory at the Portland Cement Exhibit. One of the main goals of the Model Testing laboratory was to test concrete, reinforced concrete, concrete block, and concrete block machinery:

A very complete series of tests on building blocks has been started. The series now in hand consists of molding mortar blocks using the standard cement and Meremac River sand with six different types of block machines and using three consistencies, dry, medium, and wet, and mixing in three proportions, 1 to 3, 1 to 5 and 1 to 8.

The blocks are stored under different conditions in order to determine the effect of different methods of storage. Some are kept under wet burlap, others are kept wet by simply sprinkling, and a third lot are stored in a steam room. They are investigated as to their fire-resisting qualities, transverse and crushing strength. About three hundred blocks have been tested for crushing and transverse strength before being fired. In the fire tests the blocks are tested both with and without the subsequent application of water. The blocks fired are 60 days old, while the other blocks are tested for transverse and compressive strength at 30, 90, 180, and 360 days. The blocks are molded in the same manner by the same men, out of identical materials in a number of different types of block machines, and are cured

in various ways. Some 2,000 blocks have so far been made, and about the same number tested.⁶⁶

These tests involved dozens of Portland cement companies and numerous concrete block manufactures. It was the first comprehensive test of concrete that crossed corporate lines.⁶⁷

Due to time constraints, only a limited number of tests could be conducted during the duration of the Expo, but ultimately the successes achieved within the Model Testing Laboratories prompted further investigation. After the closing of the Expo appeals were made to St. Louis and the Federal government to fund the further investigation of concrete and other building materials. The United States Geological Survey prompted Congress for appropriations, and in 1905 the sum of \$12,500 was given to further the endeavor.⁶⁸

After the initial appropriation of \$12,500 from Congress, the Secretary of the Interior requested that an advisory board be established to oversee the testing taking place in St. Louis.⁶⁹ Presidents of National Societies that had an interest in concrete and

⁶⁶ American Society of Testing Materials: *Proceedings of the Tenth Annual Meeting*, Vol. II, (1907), 340.

⁶⁷ *Ibid.*, 396.

⁶⁸ Richard L. Humphrey, *Structural-Materials testing Laboratories at St. Louis, Mo.* (Washington D. C. 1908), 2.

⁶⁹ Richard L. Humphrey, *Organization, Equipment, and Operations of the Structural-Materials Testing Laboratories at St. Louis, MO.*, U. S. Geological Survey, (Washington D. C.: Government Printing Office, 1908) 3.

reinforced concrete construction were chosen to sit on the board. Following is just a few of the organizations from where representatives were chosen:⁷⁰

- The American Institute of Mining Engineers
- The American Institute of Electrical Engineers
- The American Society of Civil Engineers
- The American Society of Mechanical Engineers
- The American Society for Testing Materials
- The American Institute of Architects
- The American Railway Engineering and Maintenance of Way Association
- The American Railway Master Mechanics' Association
- The Association of American Portland Cement Manufacturers
- The Geological Society of America
- The Iron and Steel Institute
- The National Association of Cement Users
- The National Board of Fire Underwriters:
- The National Fire Protective Association
- The Corps of Engineers

The diverse list of parties is interesting, and is a testament to how important concrete was becoming in America. In March 1906, the board members received direct appointments from President Theodore Roosevelt.⁷¹ With support of the Federal

⁷⁰ Ibid., 3.

⁷¹ Ibid.

Government money soon followed and during the years of 1906 and 1907, the Congress appropriated \$100,000. The Congressional Fiscal Bill stated:

For the continuation of the investigation of structural materials belonging to or for the use of the United States, such as stone, clays, cement, and so forth, under the supervision of the Director of the United States Geological Survey, to be immediately available, one hundred thousand dollars.⁷²

What followed were the most comprehensive tests conducted on concrete and concrete block to date, and the data gathered would usher in a century-long concrete building boom. Concrete and concrete block tests yielded information about mixing, molding, storage, strength, and fire resistance.

Richard L. Humphrey, the first president of the National Association of Cement Users, gave a speech during the third annual meeting of that organization in 1907 about the testing taking place at St. Louis:

The work at St. Louis, as you know, was organized some two years ago, and the very limited appropriation available was insufficient for doing anything more than getting a start, and it was not until June of the past year that an appropriation of \$100,000 was made for the investigation of structural materials, and by vote of the various people who have acted in an advisory capacity on the expenditure of this money, it was decided that it should be expended for investigations of cement

⁷²Ibid.

mortars and concretes. Naturally, that is an extensive field, and it was difficult to tell just what phases of it should be taken up first.⁷³

Humphrey continued to describe in detail the specific elements of the concrete block testing laboratory:

In the concrete block laboratory we have some six machines, which typify the various machines on the market, such as the two-piece block, single and double air space block, the down faced block, the wet process block, that is, the sand molded block, and so on.

Those blocks are all made with the same sand, with different proportions and consistencies. The blocks are stored in damp chambers and are tested for their physical strength, and also shipped to Chicago, where they are being tested in the furnace at the Underwriters' Laboratory for their fire-resisting qualities.

The force at St. Louis consists of about forty men, which will be materially added to this year, and there is every reason to believe that the information will come at regular intervals. When the series of tests on blocks is completed, the value of blocks made under different conditions of different materials will be pretty well established. Certainly, some of the strength values that are needed in the drafting of an ordinance will be obtained, such as the compressive strength the block ought to have at a given period, what the modulus of rupture should be, and what the

⁷³ National Association of Cement Users, *Proceedings of the Third Annual Convention*, V. III, (1907), 283.

absorption should be. We will also be able to tell you more about the process of steam curing, how a block should be cured in steam in order to develop its qualities in a very short time.⁷⁴

The building block section of the structural-materials testing laboratories tested five block machines, provided by five different companies; they were:⁷⁵

- The American Hydraulic Stone Co., Denver Co.
- Miracle Pressed Stone Co., Minneapolis Minnesota
- P. B. Miles Manufacturing Co., Jackson Michigan
- Dykema Co., Grand Rapids, Michigan
- Century Machine Co., Jackson Michigan

The five different blocks were tested by utilizing different proportions of cement, aggregates, and water.⁷⁶ Also, blocks of varying ages were used within the testing.⁷⁷ The testing was also broken down into five different categories:

- Mixing & Molding
- Storage
- Strength Tests
- Fire Tests
- Permeability

⁷⁴ Ibid., 284.

⁷⁵ Humphrey, *Organization, Equipment*, 69.

⁷⁶ Ibid., 68.

⁷⁷ Ibid., 68.

The St. Louis Expo was also the seminal point in America where concrete block was made familiar to architects, academics, builders, and millions of citizens. A 1907 Engineering Journal noted:

The cement block machine has preempted the 'territory from the Atlantic to the Pacific and from the Lakes to the Gulf.' The exhibits made at the St. Louis Exposition in 1904 gave the people some idea of the magnitude of this new industry, and in my humble opinion did more to break down the prejudice of the devotees of the "old system" than anything that has occurred.⁷⁸

Awards were also presented to concrete block manufacturers and manufacturing systems by the authority of the Expo, and this gave a legitimacy that it had never seen before. A progressive minded publication that came out the same year as the St. Louis Exposition stated:

The U. S. Arsenal at Watertown, N. Y., has made a very complete test of cement blocks and the Jackson Cement Machinery Co., of Jackson, has the best and largest exhibit of any machines on the grounds at the Universal Exposition at St. Louis. This company is receiving encouragement and praise from all parts of the country wherever their machines have been exhibited. The Normandin Cement Concrete Block Machine is taking the lead over all other machines of this nature in the United States and Canada as well as in several foreign countries. The Jackson Company has today over 250 plants in operation and has never had a

⁷⁸ *The Iowa Engineer*, Vol. VII, No. I, January (Ames, Iowa, 1907) 12.

machine returned nor is there any dissatisfaction from the workings or the product of said machines.⁷⁹

The American Hydraulic Stone Co. also won an award at the St. Louis Exposition. In a promotional catalogue it was stated, “The Gold Medal awarded to The American Hydraulic Stone Company by the International Jury of Awards at the St. Louis World’s Fair in 1904 was the only award made to any system of hollow concrete walls and partitions.”⁸⁰

The St. Louis Expo played an important role in catapulting concrete block onto the world’s stage. Because of the Expo, people outside of the building trades industry started to take notice of the capabilities of concrete blocks.

⁷⁹ *The Gateway; Literature, Commerce and Development*, (Detroit, MI, 1904). 38.

⁸⁰ *The American Hydraulic Stone Company, Ferguson System Concrete Construction*, Denver, Co., Authors Collection, 6.

Conclusion

Concrete block's evolution as a building material in America spans the better part of the 19th century, but it was not until the turn of the 20th century that it gained acceptance by architects, builders, and the country as a whole. Its acceptance is largely due to its practicality, and it became practical as a direct result of the emergence of a domestic Portland cement industry. From Aspin's first discovery of Portland cement to Ranger's first experiments in concrete block construction, these two innovations have been historically linked. The Portland cement industry in America reduced the price of cement, and because of this, concrete became a viable building material.

As the Portland cement industry gained momentum during the 1890's, numerous individuals were experimenting with concrete block machinery. Although Harmon S. Palmer invented a practical cast iron machine for making concrete block, he was not the sole originator of the hollow block form, or the block machine itself. Shortly after Palmer patented his cast iron machine in 1900, a plethora of block machines hit the patent office in Washington D. C. Some of these machines had similarities, but many of them were distinctly different. Palmer never proved his claim of being the sole originator of

the hollow block form, because it had been around for decades prior to his invention. There is no evidence to date to suggest that the numerous block machines that came out during the first decade of the 20th century had anything to do with Palmer's invention.

As the Portland cement industry was increasing its production and innovations in concrete block machinery were being realized, these two industries had a perfect platform to promote their products at the 1904 St. Louis Exposition. The Expo played an integral part in the promotion of Portland cement and concrete block. Directly following the Expo, Portland cement production increased tremendously, and concrete block machinery began to be widely marketed.

The testing that evolved out of the Fair proved to be a seminal point in the history of concrete in America. The initial model testing laboratory at the Expo and the eventual structural materials laboratory that came out of it, proved to be invaluable in establishing future standards for concrete construction. These tests and the Expo helped in legitimizing concrete block.

There seems to be a high point around the years 1905 to 1906, when people of all classes were building commercial and residential concrete block buildings. Many architecturally significant buildings were built of concrete block during this period. It has yet to be determined why the initial energy that revolved around concrete block faded away by the 1930's. Aesthetic issues aside, the most likely reason is that many of the concrete blocks manufactured during the first two decades of the 20th century were constructed using poor techniques and inadequate machinery. Many concrete block

buildings were poorly built during this time, and the inexperience of builder's in the use of concrete perpetuated the uncertainty about the material.

Unfortunately, the negative attitudes toward concrete block still exist today among many architects, preservationists, and academics. During conversations with many people about concrete block, it has become apparent that many people have little knowledge, let alone interest, in concrete block as a building material.

This paper acts as a primer to the reader interested in the early history of concrete block in America, and further research is necessary to truly understand how complex the industry was during the first two decades of the 20th century. It would be beneficial for a comprehensive survey to be conducted on how many different types of concrete block manufacturers operated during the first half of the twentieth century. The industry was highly complicated and was more than just a back yard business.

Throughout the research of this paper it has become evident that little concrete block machinery remains from this period. It is not known if a lot of these machines were scrapped because they were perceived to be useless, or because of economic reasons. The author has only come across two actual machines during the research of this paper; one belonging to a family member and one found through internet research. A detailed survey of the many concrete block machines would be invaluable. These machines are significant and should be preserved as a record to this innovative period in engineering and building construction.

Works Cited

- American Society of Testing Materials: Proceedings of the Tenth Annual Meeting*. Vol. II, 1907.
- Audley, James A., *Silica and the Silicates*. New York: D. Van Nostram, 1921.
- Bell, Joseph. *From The Carriage Age....To The Space Age...The Birth and Growth of the Concrete Masonry Industry*. Arlington, Va.: National Concrete Masonry Association, 1969.
- Brown, William Alden. *The Portland Cement Industry, A Practical Treatise on The Building, Equipment, and economical Running of A Portland Cement Plant*. New York: D. Van Nostrand Co., 1917.
- Chandler, Albert H. and Myron H. Lewis. *Popular Handbook for Cement and Concrete Users; A Comprehensive and Popular Treatise on the Principles Involved and the Methods Employed in the Design and Construction of Modern Concrete Work*. New York: The Norman W. Henley Pub. Co., 1911.
- Cocharan, Jerome. *A Treatise on the Inspection of Concrete Construction*. Myron C. Clark Pub. Co. 1913.
- Dwyer, Charles P. *The Economic Cottage Builder: On, Cottages for Men of Small Means*. Buffalo: Wanzer, McKim& Co., 1856.
- Eckel, Edwin. *Portland Cement Materials and Industry In the United States*. Department of the Interior, U. S. Geological Survey, Bulletin 522. Washington D. C.: Government Printing Office, 1913.
- Eckel, C. Edwin. *The Material and Manufacture of Portland Cement, Geological Survey*

of Alabama. Bulletin No.8, Montgomery, Alabama: The Brown Printing Company, 1904.

Eno, Frank Harvey. *The Use of Hydraulic Cement*. Springfield Publishing Co., Springfield, Ohio, 4th series, No. 2. 1904.

The Federal Reporter. "Cases Argued and Determined in the Circuit Courts of Appeals and Circuit and District Courts of the United States." Feb. – March, 1907. St. Paul: West Pub. Co., 1907.

The Gateway, Literature, Commerce and Development. Detroit, MI, 1904.

Houghton, A. A. *Ornamental Concrete, Without Molds; A practical Treatise, Explanatory of A System Of Molding Ornamental Concrete Units with Templates; Containing Additional Information on the Proper Preparation of Concrete for Ornamental Work, Proportionate Size of the Various Units and the Reinforcement Of Work*. New York: The Norman W. Henley Pub. Co., 1910.

Humphrey, Richard L. *Organization, Equipment, and Operations of the Structural-Materials Testing Laboratories at St. Louis, MO.*, U. S. Geological Survey. Washington D. C.: Government Printing Office, 1908.

Loudon, J. C. *The Architectural Magazine, and Journal of Improvements in the Architectural, Building, and Furnishing, and in the Various Arts and Trades Connected Therewith*. Vol. II, Art. VI, 1835.

Lewis, Myron H. and Albert H. Chandler. *Popular Hand Book for Cement and Concrete Users*. New York: The Norman W. Henley Pub. Co., 1911.

Morris, Ira K. *Morris's Memorial History of Staten Island*. Vol. II. New York: West

New Brighton, 1900.

Municipal Engineering, Index. Vol. XXVI, Indianapolis: Municipal Engineering Co.,
Jan.– June, 1904.

National Association of Cement Users, Proceedings of the Third Annual Convention. V.
III, 1907.

Pasley, C. W. *Observations on Limes, Calcareous Cements, Mortars, Stuccos and
Concrete, and Puzzolanas, Natural and Artificial.* London: John Weale
Architectural Library, 1847.

Radford, William A. *Cement Houses and How to Build Them.* Chicago: Radford
Architectural Company, 1909.

Reid, Homer A. *Concrete and Reinforced Concrete.* New York: The Myron C. Clark
Pub. Co., 1908.

Rice, Harmon Howard. *Concrete-Block Manufacture Process and Machines.* New York:
John Wiley & Sons, 1906.

Rice, Harmon Howard. *The Manufacture of Concrete Blocks and Their Use in Building
Construction.* New York: The Engineering New Publishing Co., 1906.

Rothwell, Richard P. *The Mineral Industry, Its Statistics, Technology and Trade During
1905.* New York: Engineering and Mining Journal, 1906.

Taylor, Frederick W. and Sanford E. Thompson, *A Treatise on Concrete Plain and
Reinforced, Materials, Construction, and Design of concrete and Reinforced
Concrete.* New York: John Wiley & Sons, 1916.

Transactions of the Society of Civil Engineers. Vol. LIV. New York: International

Engineering Congress, 1905.

Scientific and Technical Societies and Institutions of the United States and Canada,

National Research Council. Washington D. C., 4th Ed., No. 106, 1942.

Stirtz, Mary M. *Goodfellow / Julian Concrete Block District*, National Register of
Historic Places Inventory Form, October, 1986.

Whipple, Harvey. *Concrete House, How They Were Built.* Detroit: Concrete-Cement Age
Publishing, 1920.

Appendix

Concrete Block and Block Machine Patents

Issued by the United States Patent Office: 1855 - 1906

Foster & Messinger:

Building Block.

N^o 12,264.

Patented Jan. 16, 1855.

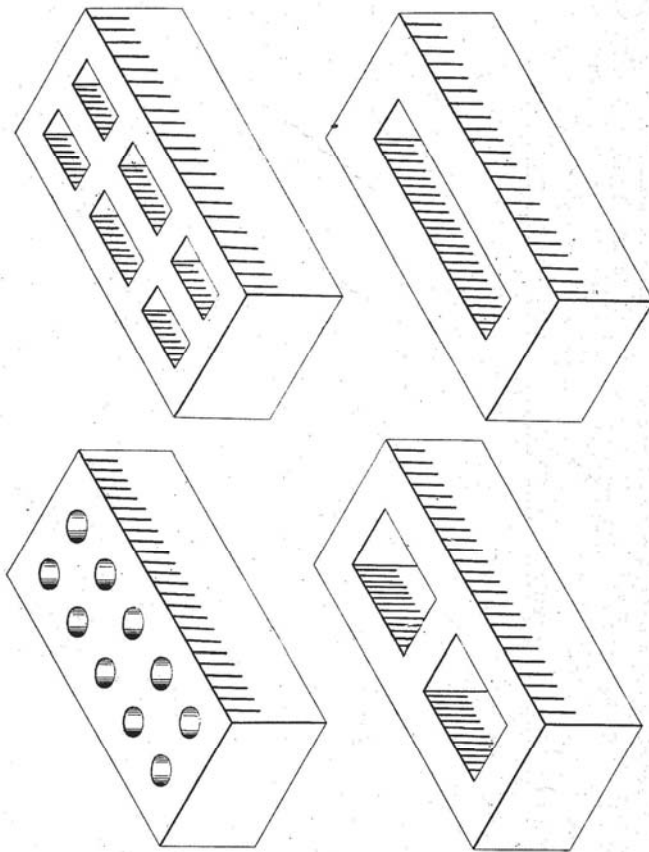

Patent 1: Ambrose Foster & E. A. Messinger, *Building Block*,
Patent No. 12,264, Jan. 16, 1855.

UNITED STATES PATENT OFFICE.

AMBROSE FOSTER, OF PORTLAND, WISCONSIN; E. A. MESSINGER AND WM. A. SPENCER,
ADMINISTRATORS OF JOHN A. MESSINGER, DECEASED, LATE OF MILWAUKEE, WIS-
CONSIN.

BUILDING-BLOCK.

Specification of Letters Patent No. 12,264, dated January 16, 1855.

To all whom it may concern:

Be it known that AMBROSE FOSTER, of Portland, in the county of Dodge, and JOHN A. MESSINGER, deceased, late of Milwaukee, in the county of Milwaukee, both in the State of Wisconsin, have invented a new and useful Building-Block as a Substitute for Bricks and Stones, of which the following is a full, clear, and exact description, reference being had to the accompanying drawings, which represent building-blocks of various forms made according to this improved plan.

The bases of this improved building block are lime and sand, articles which are old and well known materials for building purposes, and have been used in combination in a great variety of relative proportions, under innumerable forms, either as mortar to cement stones or bricks together, as concrete to make foundations, or as molded and dried blocks of mortar; but this invention is clearly distinguishable from all these and other things before known, for although it is composed of such old and well known materials, yet these materials are so combined as to give to the block new properties and advantages essentially different from those possessed by any other known artificial building material. The manner in which these new building blocks are formed is as follows:—A quantity of coarse siliceous sand, as free as possible from admixture with clay or other earths is provided, together with a quantity of good freshly slaked lime in powder. Each of these should be sifted to separate any coarse lumps it may contain. As much sand and lime as can be molded into blocks during an hour, are then to be thoroughly mixed together, in the proportions of about one part, by measure, of lime, to twelve parts of sand, the lime being the dry powdery hydrate produced when lumps of calcined limestone are freshly slaked, and the sand being as damp, as it ordinarily is when dug out of the earth. This composition is next placed in molds of the proper shape, in a molding press, similar to those in common use for making bricks from pulverulent clay, and is there submitted to great pressure which should be proportioned to the thickness of the block required. A suitable pressure for a block which, when finished would be ten inches long, four inches

wide, and three inches thick, would be one hundred and twenty tons, or three tons to the inch. Thinner blocks would of course require less, and thicker more pressure than this. When the block has been thus submitted to pressure, it is removed from the mold with care, and laid upon a flat surface with free access of air, where it should remain until sufficiently hardened or ripened to be built into a wall, which will be from four to twenty days, according to the thickness of the block, and the state of the weather. For the purpose of facilitating the ripening of the block, it should, where this form is admissible, be perforated with one or more holes, as represented in the drawings. These admit the carbonic acid of the atmosphere into the central part of the blocks, and thus convert the hydrate of lime into carbonate, which change, if the blocks were large and solid, might not take place for years. The particles of sand in the composition are forced by the heavy pressure to which the block is subjected, into such close proximity that it requires but very little cement to fill the interstices, and agglomerate them together into a block of compact sandstone. Hence a small proportion of lime furnishes an abundance of cement. The blocks thus made become indurated after a few months to such a degree, that they are not readily distinguishable from natural sandstone such as is used in many places for building purposes; and perhaps the most appropriate name for this building block would be artificial stone. Care must be taken in the preparation of this material, not to employ wet sand, because if there is an excess of moisture to such a degree that water exudes while the block is pressing, or mortar is formed, it would be impossible to give to the mass, the requisite solidity, as the cohesion of the water to the sand and lime is so strong and its incompressibility is so great that it could not be expressed in the very brief space of time to which the pressure of the block in the process of manufacture is necessarily limited. This excess of water would afterwards be evaporated leaving the block, comparatively, porous, light, and friable, and it would not maintain its shape, would crack in drying, would be much longer in hardening, and would never attain that degree of induration necessary to

Patent 1: Ambrose Foster & E. A. Messinger, *Building Block*, Patent No. 12,264, Jan. 16, 1855.

constitute it a good building material; these are the objections to the blocks of mortar before referred to.

5 If the lime should be of poor quality such as is made in some sections of the country from a siliceous magnesian limestone, it might require one bushel of lime to six of sand. Again, if sharp, washed, sand is of very coarse grain, it will require more lime than if of fine grain; if it is loamy and fine, 10 it will require more or less lime according to the nature of its impurities.

When sand is not readily obtainable, the coarsely pulverized scoria of furnaces, 15 bricks, &c., and other pulverulent siliceous matter may be employed in place of the sand.

The lime and sand may be mixed with the oxids of metals or other coloring matter, to 20 give the blocks any desired color.

25 These blocks dry without shrinking or warping, and hence, possess in these particulars, great advantages over bricks, which always shrink much, and very unequally, and also warp in burning.

Ornamental devices too, may be molded upon these blocks, which could not be formed upon any kind of a brick or block, that required burning, without increasing the expense beyond what would be justified 30 by the value of the brick, when finished.

As sand and lime, can be obtained cheaply in nearly all sections of the country where buildings are required, and no expense for burning, or making, filling, and emptying 35 kilns is necessary in the manufacture of these blocks, as in brick making, they will in most places cost less than bricks and will supply a good and cheap building material, which has long been a great desideratum. 40

The building block herein described, is claimed as a new manufacture.

AMBROSE FOSTER.

ELIZABETH A. MESSINGER,

WILLIAM A. SPENCER,

Administrators of the estate of John A. Messinger, deceased.

Witnesses:

E. L. PHELPS,

E. M. JOSLIN.

Patent 1:Ambrose Foster & E. A. Messinger, *Building Block*, Patent No. 12,264, Jan. 16, 1855.

T. B. RHODES.
Building-Blocks.

No. 149,678.

Patented April 14, 1874.

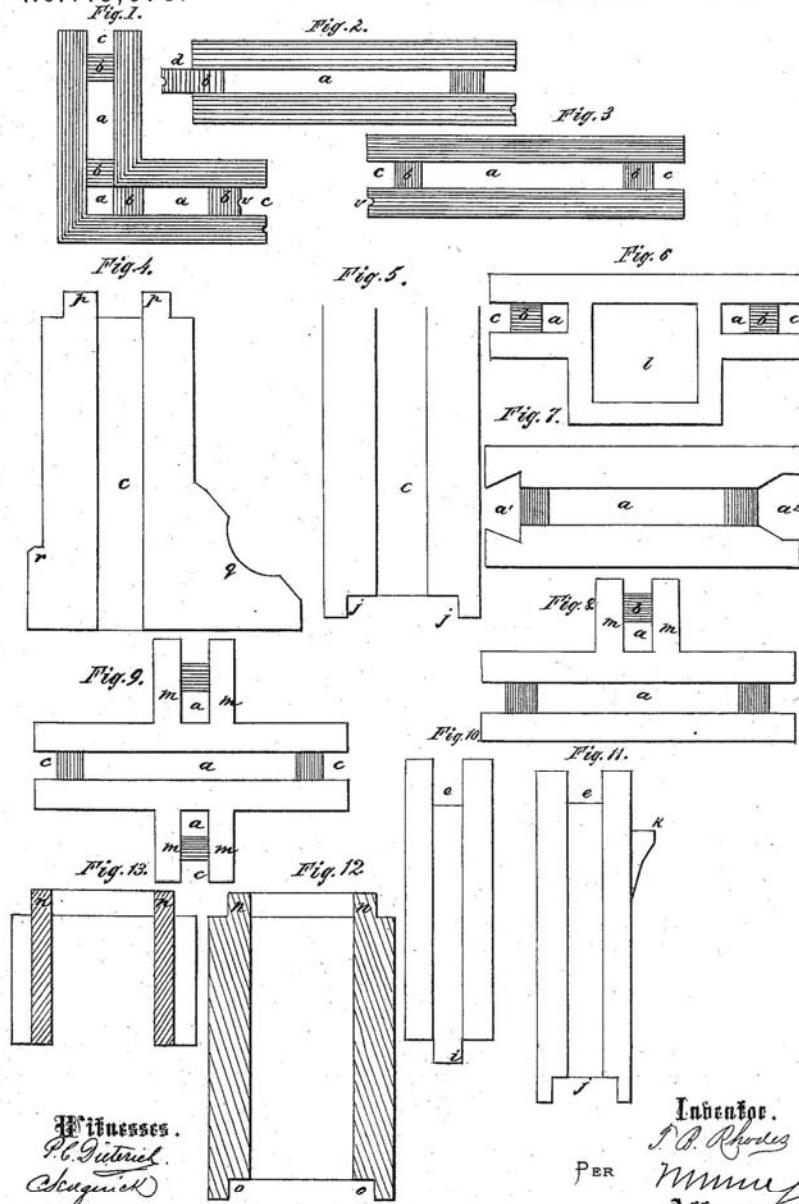

Witnesses.
P. C. Ginter.
(Clerk)

Inventor.
T. B. Rhodes
PER
Munn & Co.
Attorneys.

Patent 2: Thomas B. Rhodes, Improvement in Building-Blocks, Patent No. 149,678, April, 14, 1874.

3 Sheets--Sheet 2.

T. B. RHODES.
Building-Blocks.

No. 149,678.

Patented April 14, 1874.

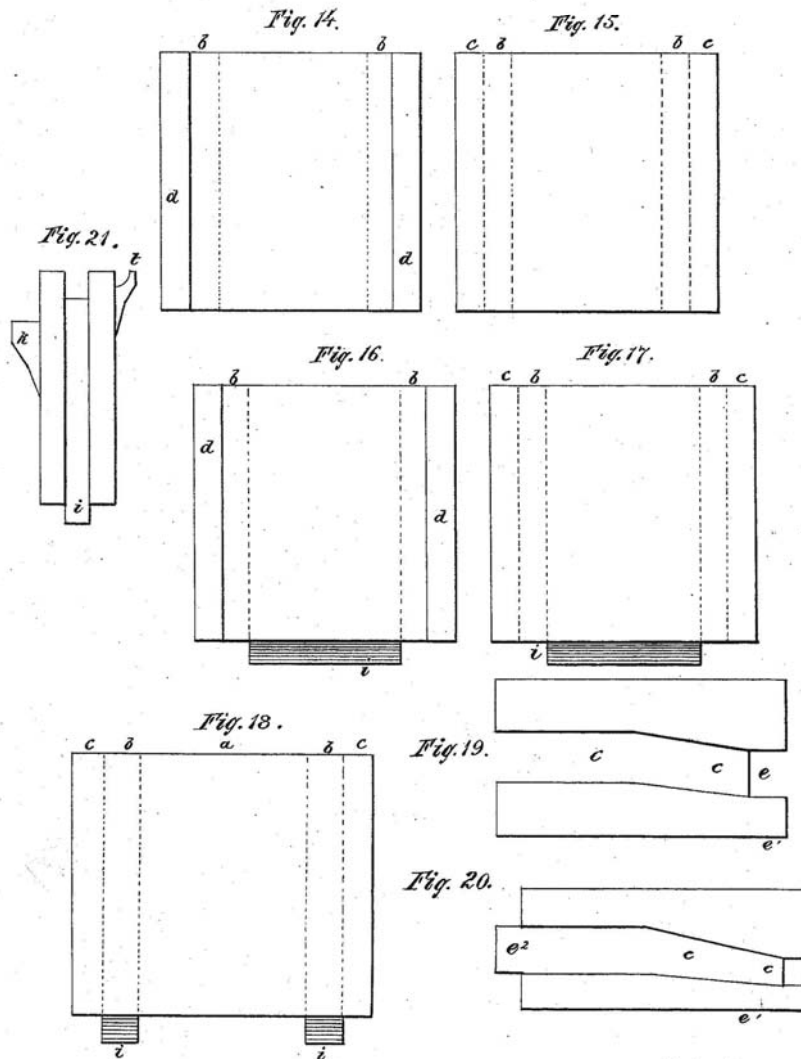

Witnesses.
P. C. Quinlan,
W. J. Quinlan

Inventor.
T. B. Rhodes
 PER *Munnell*
 Attorneys.

Patent 2: Thomas B. Rhodes, *Improvement in Building-Blocks*,
 Patent No. 149,678, April, 14, 1874.

Patent 2: Thomas B. Rhodes, *Improvement in Building-Blocks*,
Patent No. 149,678, April, 14, 1874.

thick base sections, Figs. 4 and 5, will be locked by a wide groove, *j*, in one, and a wide tongue, *p*, on the other, in the same manner that the upper tiers are joined. The base-blocks may have a base-rib, *q*, on the outside, and a mop-board rib, *r*, on the inside.

In Figs. 19 and 20, the grooves *C* in the ends of the blocks are crooked so as to match blocks of different thickness, to diminish the thickness of the walls at the floors of high buildings. The groove *e* in the top of the block is brought as much nearer the outside *e'* of the wall as is necessary for receiving the tongue *e''* of the block of the next tier above, so that its outside, *e'*, will be flush with the outside of the block below while its tongue is in the middle.

In Fig. 21, the upper-tier block is represented with a tongue, *i*, for locking with the groove of the tier below, a joist-bracket, and a grooved projection, *t*, on the outside for an eaves-trough.

In some cases, I will have the meeting ends of the blocks grooved, as at *U*, to form holes, when joined together, to fill with cement to unite them and make the joints water and air tight.

By molding these blocks they can be readily and cheaply made, in any approved form and size, both plain and ornamental, and thus afford desirable building material for less cost than bricks or wood.

I propose to construct these in several different standard sizes and thicknesses to correspond with the different stories of the building, and designate them by classes, so that by the class the size and thickness will be known.

Holes may be formed in the blocks when molded, to make continuous passages, where the blocks are joined, for conducting water from the eaves-trough to the ground; also for speaking-tubes, and the like.

In laying up a wall with these blocks, I propose to inclose each layer temporarily in a casing of wood, and pour in hot cement to flow into the interstices and fill them up and unite the blocks.

The roof-blocks, which I also propose to make of this material, according to the same general plan, with tongues and grooves to match them together, as shown at *d c*, Fig. 23, and hollow spaces, will have a recess, *p*, in the under side of the lower end, to lap over the upper end *q* of the next block below, which will be made sufficiently thinner in the upper portion than in the portion below to fit under the lower end and match with the recess, as shown.

A better elevation, *r*, will be formed on the under portion, and a corresponding rib, *s*, on the upper portion, to prevent the water from setting back in the joint. The ridge-block of one side will overlap the beveled upper end of the one on the other side, as shown at *t*, and will have a lip, *U*, at the upper end, fitting on the side of the other ridge-block, to prevent back-flow. On the under side of these blocks will be lugs or ribs *V W*, to be let into the rafters or sheathing, if any is used, to hold the blocks on the roof. The tongues and grooves will be formed, on the broken dotted lines represented in Fig. 22, to correspond with the form in which they are necessarily made for lapping each other, and said tongues and grooves will be formed in cross-section, as represented in Fig. 23—that is to say, so that the upper side of the tongue forms a little gutter through which the water that may find its way down the joint thereto will escape down to the eaves, and thus be prevented from leaking through the roof. *X* represents the hollow spaces of these blocks, which will extend from near the lower ends to the point in the upper part, where they begin to taper down to be overlapped by the block above.

I propose to make these blocks considerably thinner in the middle of the upper side than at the edges, as shown in the end view, Fig. 23, as another means of economizing material.

Y represents a rib, which will be formed on the end tier of the roof-blocks to overlap the ends of the roof.

Having thus described my invention, I claim as new and desire to secure by Letters Patent—

1. The blocks having partition-connections *m*, substantially as specified.
2. The said blocks having joist and eaves-trough brackets *k t*, substantially as specified.
3. The said blocks having the end grooves and tongues crooked to match the tiers of different thickness, substantially as specified.
4. The base-blocks having base-ribs *q* and mop-board rib *r*, substantially as specified.
5. The arrangement of the lap-joints *p q r s* of the roof-blocks, substantially as specified.
6. The arrangement of the ridge-joint *t u*, substantially as specified.
7. The arrangement of the tongues *d* of the roof-blocks for carrying off the water, substantially as specified.

THOS. B. RHODES.

Witnesses:

WM. H. WALTER,
J. M. MOWREY.

Patent 2: Thomas B. Rhodes, *Improvement in Building-Blocks*, Patent No. 149,678, April, 14, 1874.

3 Sheets--Sheet 1.

T. COOK.

Machine for Manufacturing Blocks of Artificial Stone.
No. 161,866.

Patented April 13, 1875.

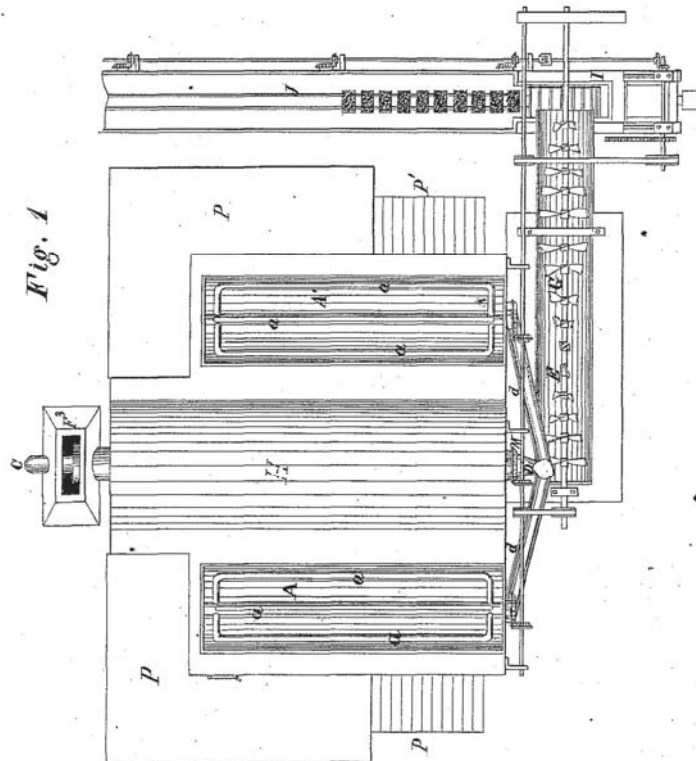

Fig. 1

WITNESSES

Ed. Warner.
M. Smith BY

INVENTOR

T. Cook
By *Wm. H. Bennett*
Attorney

THE GRAPHIC CO. PHOTO-LITH. 39 & 41 PARK PLACE, N. Y.

Patent 3: T. Cook, *Machine for Manufacturing Blocks of Artificial Stone*, U. S. Patent No. 161,866, April 13, 1875.

T. COOK.

Machine for Manufacturing Blocks of Artificial Stone.

No. 161,866.

Patented April 13, 1875.

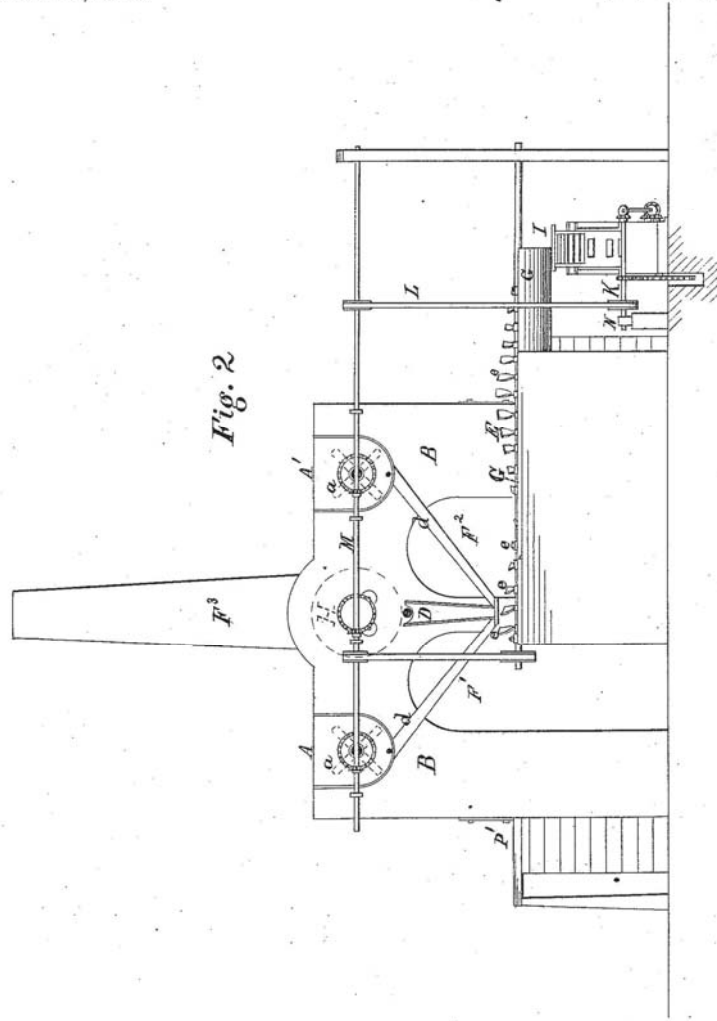

Fig. 2

WITNESSES
C. S. Warner.
M. Church BY

INVENTOR
 Thomas Cook.
 By *Wm. H. Bennett*
 His Attorney

THE GRAPHIC CO. PHOTO-LITH. 39 & 41 PARK PLACE, N.Y.

Patent 3: T. Cook, *Machine for Manufacturing Blocks of Artificial Stone*, U. S. Patent No. 161,866, April 13, 1875.

3 Sheets--Sheet 3.

T. COOK.

Machine for Manufacturing Blocks of Artificial Stone.

No. 161,866.

Patented April 13, 1875.

Fig. 3

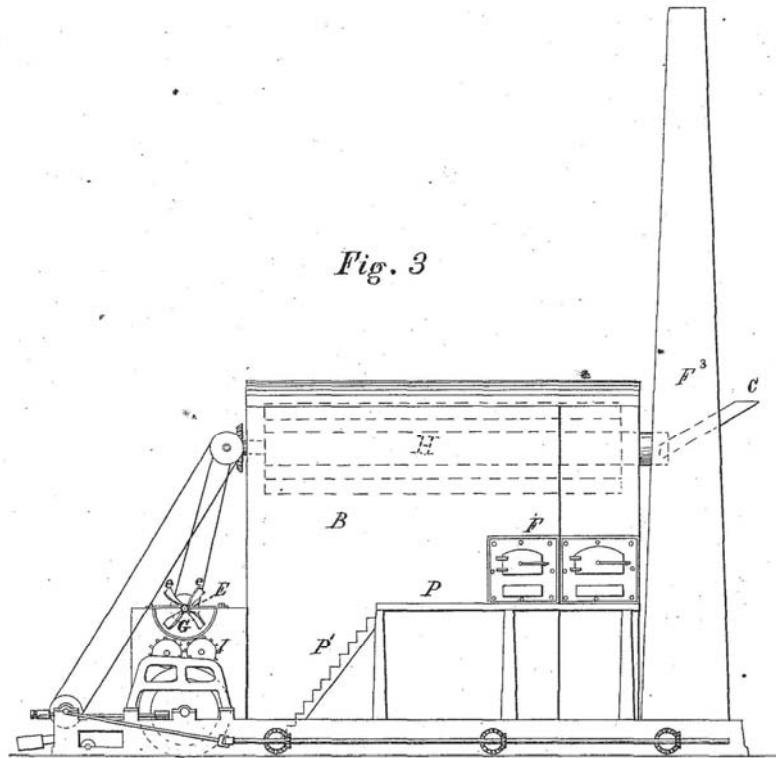

WITNESSES

E. S. Hamer.
M. Church BY

INVENTOR

Thomas Cook
By Hill & Coleman
His Attorney

THE GRAPHIC CO. PHOTO-LITH. 39 & 41 PARK PLACE, N.Y.

Patent 3: T. Cook, *Machine for Manufacturing Blocks of Artificial Stone*, U. S. Patent No. 161,866, April 13, 1875.

UNITED STATES PATENT OFFICE.

THOMAS COOK, OF SING SING, NEW YORK, ASSIGNOR TO J. R. DOS PASSOS
AND ZACHARIAH E. SIMMONS, OF NEW YORK CITY.

IMPROVEMENT IN MACHINES FOR MANUFACTURING BLOCKS OF ARTIFICIAL STONE.

Specification forming part of Letters Patent No. **161,866**, dated April 13, 1875; application filed
February 24, 1875.

To all whom it may concern:

Be it known that I, THOMAS COOK, of Sing Sing, in the county of Westchester and State of New York, have invented certain new and useful Improvements in Machinery for Manufacturing Blocks of Concrete, Artificial Fuel, &c.; and I do hereby declare the following to be a full and exact description of the same, reference being had to the accompanying drawings forming part of this specification, in which—

Figure 1 is a top plan view of the machinery for carrying out my invention. Fig. 2 is a front elevation, and Fig. 3 is a side elevation, of the same.

Similar letters of reference in the accompanying drawings denote the same parts.

The object of this invention is to provide for the public an improved combination of mechanism for the more rapid, convenient, and effective treatment of the materials used in making artificial concrete blocks, artificial fuel, and other blocks of similar character, and for combining said materials, compressing them to form the blocks, and delivering the completed blocks from the machine, in such a manner as to effect the utmost possible saving of time and of hand-labor, and produce the most perfect blocks at the least practicable expense.

This object I accomplish by means of my improved combination and arrangement of mechanism adapted to heat the asphalt or other equivalent material, heat the ground, pulverized, or granular stone, or other equivalent thereof, convey said heated stone and heated asphalt to a mixing-vessel and discharge them together thereinto, thoroughly mix and incorporate them together, convey the mixed materials to the press and compress them into suitable blocks, and, if desirable in any particular case, convey the completed blocks away to a suitable receptacle, or to the place where they may be wanted for use.

My invention consists, first, in the improved combination and combinations of mechanism, for the purposes referred to, and as I will more particularly hereinafter describe; secondly, in an improved arrangement of mechanism by

which one of the vessels employed for heating and stirring the asphalt may be delivering the melted asphalt to the mixing-vessel while the other is heating up a new charge of asphalt to be used in its turn with the mixer, as I will also proceed to describe; and, thirdly, in the improved process of manufacturing the blocks by machinery without the intervention of hand-labor.

In the drawings, B is a brick structure adapted to the proper support and convenient arrangement of the apparatus, and provided with a furnace, F, for heating the granulated stone or equivalent material in its passage through the apparatus; a furnace or furnaces, F¹ F², for heating one or both of the asphalt-vessels; a smoke-flue, F³; and, if preferred, a suitable furnace under the mixing-vessel for the purpose of keeping the materials at the proper temperature for mixing in cold weather. In lieu of this last-mentioned furnace, a flue or flues from either of the other furnaces, provided with regulating-dampers or cut-offs, may be caused to pass under or beside the mixing-vessel, or a set of steam-pipes or hot-water pipes from a suitable boiler may be arranged to control and regulate the temperature of the materials in the mixer. A variety of suitable arrangements for this purpose will readily suggest themselves to the mind of any skilled mechanic familiar with the state of the art without further description herein.

A suitable platform, P, provided with steps P¹ and guard-rail, may be arranged to accommodate the workmen in attending to the fires, inspecting the progress and condition of the work, supplying the materials, &c., and the form of this platform must in all cases be adapted to the form of the brick structure, the arrangement of the vessels and furnaces, the nature of the work, &c.

The brick structure having been thus provided and adapted to its appropriate functions, the mechanism which I employ in connection with it may be described as follows: C is a chute, through which the ground or pulverized stone, or other granular or pulverulent material, is fed to the apparatus, said feed-chute being provided with a suitable con-

Patent 3: T. Cook, *Machine for Manufacturing Blocks of Artificial Stone*, U. S. Patent No. 161,866, April 13, 1875.

3. The process of heating the stone, heating and stirring the asphalt, delivering the stone and the asphalt into the same mixing-vessel, mixing them thoroughly therein, discharging them, thus mixed, into the press, and molding and compressing them into blocks, and delivering the blocks from the press, finished and ready for use, by the

operation of machinery, as above described, and without the intervention of hand-labor at any stage, substantially as herein set forth.

THOMAS COOK.

Witnesses:

WM. H. MINNIX,
M. CHURCH.

Patent 3: T. Cook, *Machine for Manufacturing Blocks of Artificial Stone*, U. S. Patent No. 161,866, April 13, 1875.

W. H. SMITH.
 MACHINES FOR THE MANUFACTURE OF ARTIFICIAL STONE.
 No. 177,578. Patented May 16, 1876.

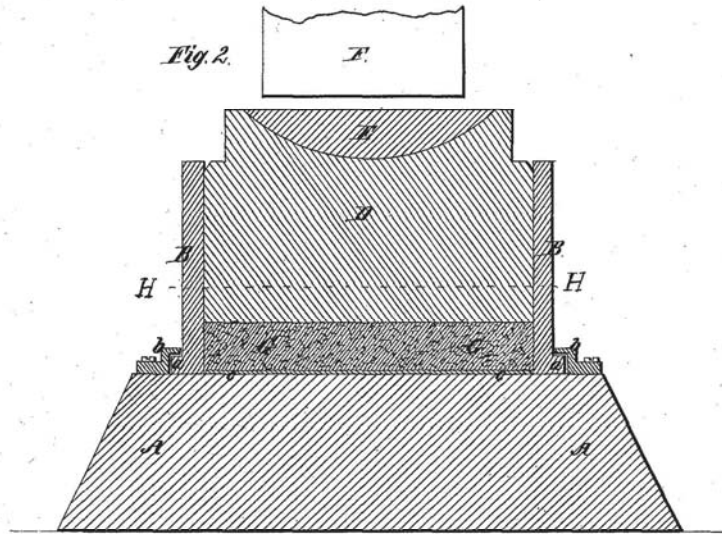

Fig. 2.

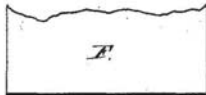
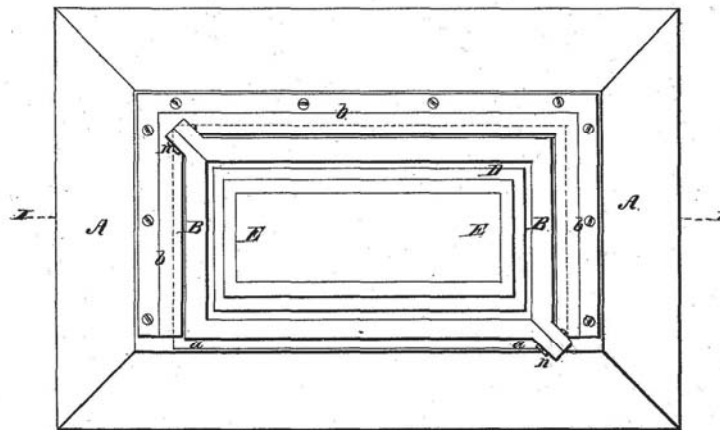

Fig. 1.



Witnesses.

Joseph Lippman
Theo. Pfaffhuos

Inventor.

W. Harold Smith

Patent 4: W. H. Smith, *Machine for the Manufacture of Artificial Stone*, U. S. Patent No. 177,578, May 16, 1876.

UNITED STATES PATENT OFFICE.

W. HARROLD SMITH, OF PHILADELPHIA, PENNSYLVANIA.

IMPROVEMENT IN MACHINES FOR THE MANUFACTURE OF ARTIFICIAL STONE.

Specification forming part of Letters Patent No. 177,578, dated May 16, 1876; application filed October 7, 1875.

To all whom it may concern:

Be it known that I, W. HARROLD SMITH, of the city of Philadelphia and State of Pennsylvania, have invented certain Improvements in the Method of Manufacturing Artificial Stone, of which the following is a specification:

My invention consists in the arrangement of devices for applying percussive force to the material of which the artificial stone is composed while the same is in a semi-plastic state, whereby the material is wrought into a condition more closely resembling natural stone than can possibly be effected by other known means.

To accomplish this result I employ the following mechanism, the description of which will be best understood by reference to the accompanying drawings, which show the principal portions of my apparatus in plan, Figure 1, and sectional elevation, Fig. 2.

A is a solid anvil of iron or steel, upon which a mold, B B, is slid and securely fastened by means of the flange *a a* and clips *b b*, or any equivalent mechanical device. This mold is in two or more parts, and can be separated by unscrewing the nuts *n n*, by which its sections are held together. The under face of the flange *a a* is armed with rubber or other packing, so as to secure an air-tight joint all round. C C is a thin metallic plate fitting accurately inside the mold, and held in position flush with the under face of flange *a a* by springs, (not shown in the drawings,) which are withdrawn so as to release the plate by the mere act of securing the mold to the anvil.

The object of this arrangement is to allow the mold to be filled at a distance, the whole office of the plate being to prevent the material from escaping while the mold is being handled. It is not an essential feature of my invention, but may be dispensed with and the mold filled after it is in position on the anvil, or upon a table having its surface continuous therewith, so that the mold, after filling, may, without lifting, be slid directly under the hammer.

There are a series of minute holes pierced, at convenient places, in the sides of the mold

or through the top of the die, to allow the escape of compressed air. (They are not shown in the drawings.) D is a die or plunger of metal, made to fit accurately into the mold B, and bearing upon its upper surface a mass, E, of slightly-elastic metal or wood, designed to take up a portion of the blow given to the die, so as to break the dead force of impact and prevent injury to the apparatus, such an expedient being absolutely necessary to this manufacture. This mass E may also consist of hard rubber, or it may be replaced by a system of springs or other equivalent mechanical device, or, finally, such expedients may be transferred to the anvil and act beneath the material, instead of being seated upon the die and acting above it. F (not shown in Fig. 1) represents the hammer of a steam-hammer, or any power-hammer of equivalent character.

The operation is as follows: The plate C C is fixed in position within the mold B B, which is then filled with the plastic material out of which the block is to be made to the level of the line H H, and the die D inserted thereon. The mold so filled is next slid upon the anvil A A, and fastened securely beneath the hammer F, which thereupon, by repeated blows, forges the block into the required consistency and thickness. The air compressed in the operation is allowed to escape through the minute holes pierced in the body of the mold, as already described. The forged block is readily released from the mold by unscrewing the nuts *n n*.

I do not claim the steam-hammer, nor the die and mold with its plate, nor the compressed-air-escape holes.

I claim as my invention—
The combination of a power-hammer, F, with an anvil, A, mold B, die D, and sub-elastic mass E, to effect the compacting and solidification of the semi-plastic material of which artificial stone is composed under powerful percussion, substantially as described.

W. HARROLD SMITH.

Witnesses:
JOSEPH LIPPMAN,
THEO. P. MATTHEWS.

Patent 4: W. H. Smith, *Machine for the Manufacture of Artificial Stone*, U. S. Patent No. 177,578, May 16, 1876.

(No Model.)

J. C. SELLARS.

APPARATUS FOR MOLDING CONCRETE AND ARTIFICIAL STONE.
 No. 244,322. Patented July 12, 1881.

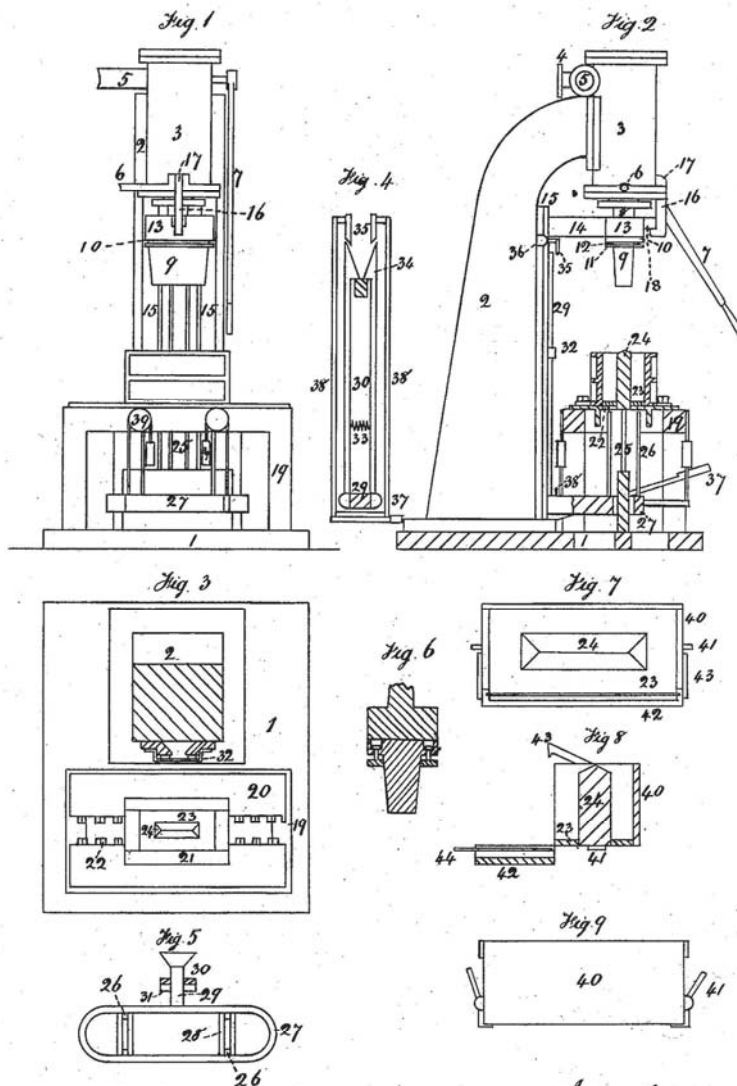

Witnesses
J. Johnson
M. Melman

Inventor
J. C. Sellars.

N. PETERS, Photo-Lithographer, Washington, D. C.

Patent 5: J. C. Sellers, *Apparatus for Molding Concrete and Artificial Stone*, U. S. Patent No. 244,322, July 12, 1881.

UNITED STATES PATENT OFFICE.

JOHN C. SELLARS, OF BIRKENHEAD, COUNTY OF CHESTER, ENGLAND.

APPARATUS FOR MOLDING CONCRETE AND ARTIFICIAL STONE.

SPECIFICATION forming part of Letters Patent No. 244,322, dated July 12, 1881.

Application filed May 31, 1881. (No model.) Patented in England September 23, 1876, and December 27, 1877.

To all whom it may concern:

Be it known that I, JOHN CARRINGTON SELLARS, of Birkenhead, in the county of Chester, England, manufacturing chemist, have invented a new and useful Apparatus for Molding Concrete and Artificial Stone, (for which I have obtained Letters Patent in Great Britain, No. 1,279, bearing date September 23, 1876, and No. 4,905, bearing date December 27, 1877,) of which the following is a specification.

My invention relates to apparatus for molding concrete and artificial stone when in a semi-plastic condition into various forms, such as hollow blocks, slabs, linings, jointings, ridge-tiles, window-heads, and the like, employed in buildings.

Hitherto apparatus for molding concrete and artificial stone has not been so constructed as to produce with facility blocks or pieces having the desired shapes truly and correctly made so as to present a neat and finished appearance and be ready for use in buildings without further preparation other than aging.

The objects of my improvements are, first, to provide apparatus in which blocks and other pieces used in buildings may be made with facility, of various forms and sizes, truly shaped and accurately finished; and, second, to afford facilities for filling the molds and removing the molded articles.

I attain the above objects by means of the apparatus illustrated in the accompanying sheet of drawings, in which—

Figure 1 is a front elevation, Fig. 2 a side elevation, partly in section, and Fig. 3 a plan view, also partly in section, of the press or that part of the apparatus for giving the desired shape to the concrete or artificial stone, and arranged for making hollow blocks. Fig. 4 is a front elevation, and Fig. 5 a plan view, partly in section, of the apparatus for raising and lowering the ejectors for raising the finished blocks or articles out of the molds. Fig. 6 is a sectional view of the plunger for compressing the concrete or artificial stone. Fig. 7 is a plan view, Fig. 8 a sectional elevation, and Fig. 9 a front view, of apparatus for facilitating the charging of the molds with semi-plastic concrete or artificial stone.

The same figures refer to similar parts throughout the several views.

1 is a bed-plate, which may, if desired, be mounted on wheels to permit of the apparatus being easily moved from place to place; 2, standard carrying the steam-cylinder; 3, 4, 55 steam-pipe; 5, exhaust-pipe; 6, waste-water pipe. The pipes 4 and 5 are joined to a valve-box attached to the cylinder 3 and containing a valve connected to a lever, 7. The valve-box and valve are of any usual or desired kind 60 for admitting and exhausting steam from each end of a cylinder.

8 is a piston-rod; 9, body of plunger or die used only in making hollow blocks; 10, top of plunger or die; 11, suction-ring surrounding 65 body of plunger and fitted with pins 12, free to slide in holes in the top 10 of the plunger or die. The said pins are secured to the ring 11 by screwing or riveting, and are provided with heads or equivalent means to prevent the ring 70 11 from falling too low. The plunger 9 10 is secured to the piston-rod head 13 by screws or in any convenient manner, so that any desired shape of plunger or die may be used.

14 is a guide-bar secured to or forming part 75 of the piston-rod head 13. The said guide-bar works in between guide-pieces 15, secured in any usual or desired manner to the standard 2.

16 is a catch suspended from a fulcrum-pin at 17 and falling under a projection, 18, on the 80 piston-rod head 13.

19 is a frame carrying the bearers 20, which latter serve as a table to carry the mold 21. The mold 21 is cast or made in one piece, or of two or more pieces bolted together, and is secured on the bearers 20 by means of bolts or 85 equivalent fastenings. 22 are grid-projections forming part of the bearers 20. 23 is a foundation-ring, which rests on the grid-projections 22 and serves as a bottom to the mold while 90 the block or other article is being molded and as means for removing the molded block. 24 is a core supported by the concrete or artificial stone within the mold and free to slide down the guide-rods 25, which work in holes in the 95 said core. The cores and foundation-rings are of various sizes, according to the blocks to be made. The hole in the foundation-ring must be sufficiently large to let the core pass through. 100 When solid blocks are made the core is not used, and the foundation-ring has no hole through it.

Patent 5: J. C. Sellers, *Apparatus for Molding Concrete and Artificial Stone*, U. S. Patent No. 244,322, July 12, 1881.

26 represents ejectors, carried by the ring 27 and adjustable transversely in slotted carriers 28, which are themselves adjustable longitudinally in the ring 27, so as to allow of the said ejectors being placed in any desired position to insure the proper ejection of the finished block from the mold. The ejectors 26 and carriers 28 are secured in position by screws, nuts, clips, or in any other well-known manner.

29 is a bar and guide secured to or made with the ring 27, and working between the guide-pieces 15; 30, lifting-rods, jointed to the bar 29 at 31, passing through a guide, 32, and held together by a spring, 33. The ends of the said lifting-rods are formed with catches 34.

35 represents disengaging-prongs, pivoted at 36 to the standard 2, and connected to the treadle 37 by the rods or their equivalents 38; 39, balance-weights to facilitate the raising of the ring 27; 40, feeding-box, fitted with catches 41, on which the foundation-ring 23 rests; 24, core; 42, hinged side to box, held in position by catches 43; 44, shutters sliding in a groove in the side 42.

The action of the apparatus is as follows: Concrete or artificial stone in a semi-plastic condition is filled into the feeding-box 40, surrounding the core 24. The said box is then lifted or run on rails over the mold 21. The catches 41 are released, and the foundation-ring, core, and contents allowed to drop into the mold, where the foundation-ring rests on the top of the grid-projections 22. The catch 16 is released and the lever 7 is moved, so as to admit steam to the top of the cylinder, the plunger or die 9 10 descends, and the portion 9 of the said plunger or die drives down the core 24, and by its taper form compresses the concrete or artificial stone sidewise. The part 10 of the plunger or die compresses the said material vertically. More than one blow of the die 9 10 may be given to insure consolidation of the block. As the plunger or die rises the suction-ring 11 sticks by suction to the top of the block until there is a space through which air can pass and allow the said ring to leave the surface of the block freely. If the suction-ring 11 were not free to remain stationary until the plunger or die had risen a slight distance, air could not get to the surface of the block, and parts of such block would adhere to the plunger or die and the upper surface would be uneven. When the block is made the lever 7 is moved until steam is admitted to the bottom of the cylinder, and the plunger or die is raised to the top of its stroke, and is held in position by the catch 16. When the said plunger or die has risen about half the distance to the top of its stroke, the guide-bar 14 engages with the catches 34 and the ring 27, and with it the ejectors 26 are raised and the foundation-ring and block are carried to the top of the mold. The foundation-ring and finished block are then removed and placed in any suitable position to age. The treadle 37 is depressed, the disengaging-prongs 35 descend and open the catches 34 until they are free

from the guide-bar 14, and the ejectors 26 and ring 27 then fall by the action of gravity. The core 24, left on the guide-rods 25 beneath the mold, is removed, and the mold is ready to be charged with fresh material.

The foundation-rings provide means for the easy removal of the finished blocks and serve as bottoms for the feed-boxes. The spaces between the grid-projections 22 allow any concrete or artificial stone left in the mold to escape, so that the foundation-ring shall bed squarely in the bottom of the mold. For the better insuring of that purpose the grid-projections 22 are tapered upward.

When one of the surfaces of a block is on the outside of a building the side 42 is opened, as shown in Fig. 8, fine concrete or artificial stone is placed thereon, the shutter 44 is inserted, and the side is closed. The interior is then filled with coarser material and the shutter is withdrawn. The contents are then allowed to fall in the mold, and a block is produced having a surface of fine or superior material. For corner-blocks one end and one side of the feeding-box 40 are hinged and provided with a shutter.

The molds and dies and feeding-boxes are varied in shape and size according to the articles it is desired to produce.

What I claim as my invention, and desire to secure by Letters Patent, is, in apparatus for molding concrete or artificial stone—

1. The combination of a plunger, an open-bottomed mold, a movable mold-bottom, a movable core, and mechanism for actuating the plunger, core, and mold-bottom, substantially as and for the purpose specified.

2. The combination of a mold, a plunger, and a loose relief or suction plate for preserving the surface of the molded article during the withdrawal of the plunger, substantially as specified.

3. In a mold-table for detachable bottom molds, the combination of the adjustable mold-bearers, having grids or projections for the support of the mold-bottom or foundation-ring, substantially as specified.

4. The combination of an open-bottom mold, a foundation-ring, and a mold-table having grids or projections which support the foundation-ring and permit the escape of surplus material, substantially as and for the purpose specified.

5. The combination, with the plunger and mold, of a movable core and guide-rods for insuring the proper movement of the core as it withdraws from the mold before the advancing plunger, substantially as specified.

6. The combination, with the open-bottom mold and foundation-ring adapted to traverse the mold, of the series of adjustable ejectors and mechanism for actuating the ejectors, substantially as and for the purpose specified.

7. The combination of a plunger, an open-bottom mold, a bottom or foundation ring movable through the mold, ejectors for lifting the foundation-ring, and a lifting-rod for actuating

244,322

3

the ejectors from the plunger, substantially as and for the purpose specified.

8. The combination, with an open-bottom feed-box, of a detachable foundation-ring and a loose core, substantially as and for the purpose specified.

9. The feed-box provided with a hinged side piece and a detachable slide or shutter for dividing the box into two compartments, substantially as and for the purpose specified.

10. The combination, with a plunger and an

open-bottom mold having a foundation-plate adapted to traverse the mold, of a series of ejectors, 26, an ejector-ring, 27, jointed spring lifting-rods 30, and the disengaging devices 35, substantially as and for the purpose specified.

JNO. C. SELLARS.

Witnesses:

T. JOHNSON,

J. RICHMAN.

Patent 5: J. C. Sellers, *Apparatus for Molding Concrete and Artificial Stone*, U. S. Patent No. 244,322, July 12, 1881.

(No Model.)

2 Sheets—Sheet 1.

H. S. PALMER.

MACHINE FOR MOLDING BUILDING BLOCKS.

No. 375,377.

Patented Dec. 27, 1887.

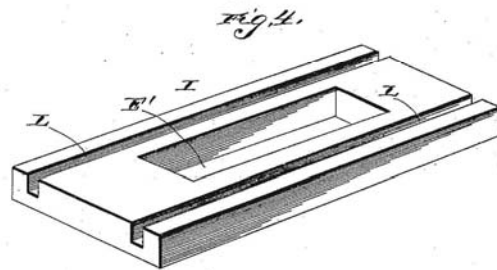
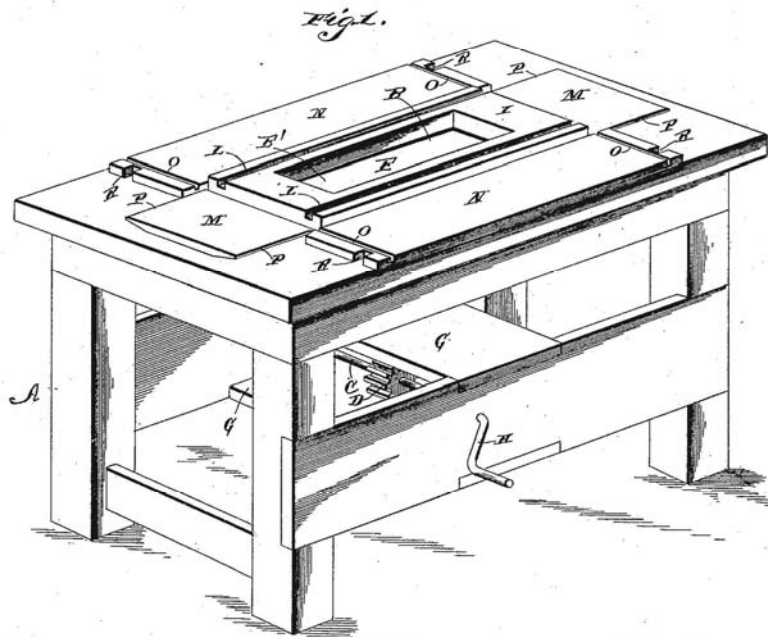

Witnesses
C. S. Taylor
J. W. Garner

Inventor
Harmon S. Palmer
 By his Attorneys
C. A. Snow & Co.

N. PETERS, Photo-Lithographer, Washington, U. C.

Patent 6: H. S. Palmer, *Machine for Molding Building Blocks*, U. S. Patent No. 375,377, Dec. 27, 1887.

UNITED STATES PATENT OFFICE.

HARMON S. PALMER, OF CHATTANOOGA, TENNESSEE.

MACHINE FOR MOLDING BUILDING-BLOCKS.

SPECIFICATION forming part of Letters Patent No. 375,377, dated December 27, 1887.

Application filed April 5, 1887. Serial No. 233,750. (No model.)

To all whom it may concern:

Be it known that I, HARMON S. PALMER, a citizen of the United States, residing at Chattanooga, in the county of Hamilton and State of Tennessee, have invented a new and useful Improvement in Machines for Molding Building-Blocks, of which the following is a specification.

My invention relates to an improvement in machines for molding building-blocks; and it consists in the peculiar construction and combination of devices that will be more fully set forth hereinafter, and particularly pointed out in the claim.

This machine is particularly adapted for molding the building-blocks described in my pending application for Letters Patent of the United States, Serial No. 227,696, filed February 15, 1887.

In the drawings, Figure 1 is a perspective view of a machine embodying my improvements. Fig. 2 is a vertical longitudinal sectional view of the same. Fig. 3 is a vertical transverse sectional view of the same. Fig. 4 is a detached perspective view of the bottom plate.

A represents a table or frame, the top of which is provided at its center with an elongated rectangular opening, B. In suitable bearings, under the top of the table and near the center thereof, is journaled a transverse shaft, C, which is provided at its center with a spur-pinion, D.

E represents a core-block adapted to move vertically in the opening B. The base of this core-block exactly fits in the said opening; but the sides and ends of the core-block are slightly inclined, as shown, and thereby the upper end of the core-block is slightly smaller than the base thereof, the core-block being thus rendered substantially wedge-shaped. From the lower side of the core-block, at the center thereof, depends a vertical bar, F, which extends through supporting-keepers G. One side of the bar F is provided with a series of rack-teeth which mesh with the pinion D. A crank, H, is provided for one end of the shaft C, and by turning the said crank the pinion is caused to rotate, and thereby either move the core-block upwardly in the opening B, or else lower it therein, according to the direction in which the shaft C is rotated.

I represents a removable bottom plate, which is provided with a central opening, E', corresponding in size and shape with the opening B. This plate I forms the bottom of the mold, and is provided on its upper side with longitudinal grooves L, for the purpose to be hereinafter explained.

M represents a pair of plates or boards which form the ends of the mold, and have their lower edges hinged to the table-top just beyond the ends of the bottom plate, I, when the latter is in position on the table-top.

N represents a pair of boards or plates which form the sides of the mold, and have their lower edges similarly hinged to the table-top just beyond the sides of the bottom plate, I. These side boards or plates, N, are provided near their ends on their opposing sides with grooves O, and the ends of the boards or plates M are beveled on their outer sides to form projections P, which are adapted to fit in the grooves O, as shown. The ends of the side boards or plates, N, are also provided near their free edges with open slots R.

S represents a pair of bolts, which are adapted to fit in the said slots and connect the side plates or boards, N, together when the latter are closed against the ends of the end plates or boards, M, and the said bolts S are provided at their threaded ends with wing-nuts T, which are adapted to clamp the side boards or plates, N, firmly in position against the ends of the end boards or plates, M.

The operation of my invention is as follows: In order to mold a building-block, the bottom plate, I, is first placed on the table-top and the sides and ends of the mold are closed against each other in the position shown in Figs. 2 and 3, and clamped in this position by means of the bolts S and the nuts T. The crank H is then turned, so as to raise the core-block in the center of the mold until the upper end of the said core-block is on a level with the upper edges of the sides and ends of the mold. Concrete or other suitable material in a semi-plastic condition is then poured into the mold and is firmly tamped therein. The bolts S are then removed from the slots R, and the sides and ends of the mold are folded downwardly upon the table-top, and the crank H is turned so as to withdraw the core-block from the center of the building-block formed

Patent 6: H. S. Palmer, *Machine for Molding Building Blocks*, U. S. Patent No. 375,377, Dec. 27, 1887.

(No Model.)

H. S. PALMER.
BUILDING BLOCK.

No. 384,541.

Patented June 12, 1888.

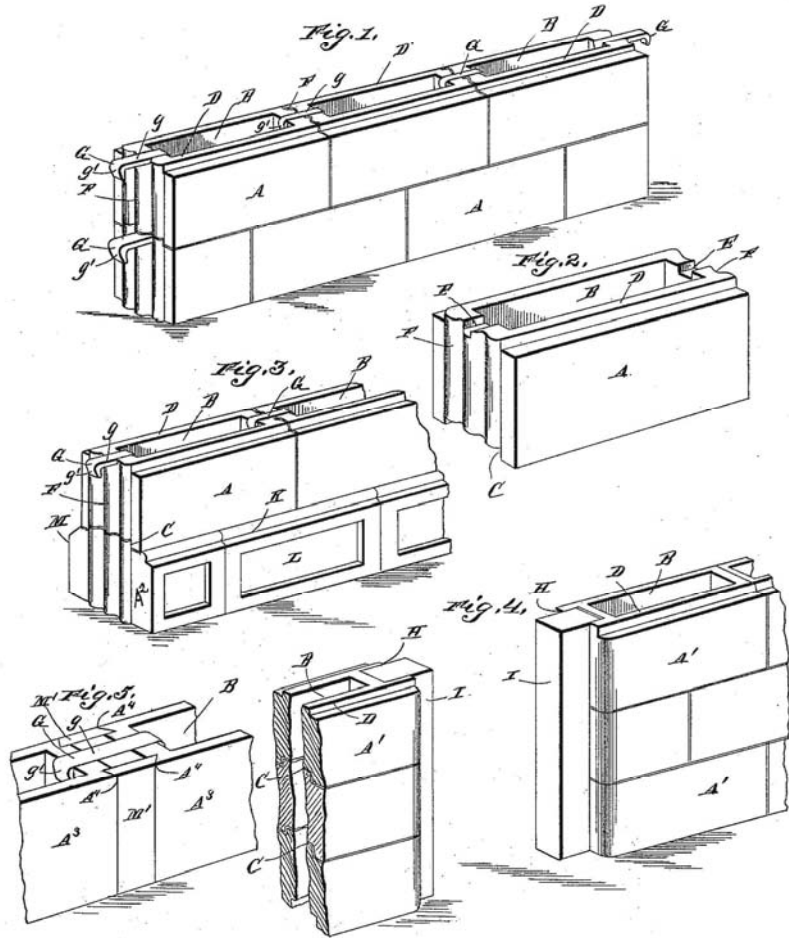

Witnesses

C. B. Taylor
E. J. Siggers

Inventor;
Harmon S. Palmer

By his Attorneys

C. A. Howard

Patent 7: H. S. Palmer, *Building Blocks*, U. S. Patent No. 384,541, June 12, 1888.

UNITED STATES PATENT OFFICE.

HARMON S. PALMER, OF CHATTANOOGA, TENNESSEE.

BUILDING-BLOCK.

SPECIFICATION forming part of Letters Patent No. 384,541, dated June 12, 1888.

Application filed February 15, 1887. Serial No. 227,696. (No model.)

To all whom it may concern:

Be it known that I, HARMON S. PALMER, a citizen of the United States, residing at Chattanooga, in the county of Hamilton and State of Tennessee, have invented a new and useful Improvement in Building-Blocks, of which the following is a specification.

My invention relates to an improvement in building-blocks for walls and other structures; and it consists in the peculiar construction and combination of devices that will be more fully set forth hereinafter, and particularly pointed out in the claim.

In the drawings, Figure 1 is a perspective view of a wall in course of erection and constructed with my improved building-blocks. Fig. 2 is a detailed perspective view of one of the blocks. Fig. 3 is a perspective view of a part of a wall of a house in course of erection, showing the lower blocks provided with moldings and panels on their inner sides to form a wash-board, and with offsets or shoulders on their outer sides to form a water-table. Fig. 4 is a similar view showing a window or door frame built into the wall. Fig. 5 is a similar view illustrating means for adjusting the length of the wall.

My building-blocks are composed of concrete molded into rectangular forms, and each block A has a vertical longitudinal opening, B, in its interior, which extends from its lower to its upper side and nearly from end to end of the block, thereby making the latter hollow, to reduce its weight and effect an economy of the material of which the block is composed.

On the lower side of the block is a longitudinal central groove, C, and on the upper side of the block is a longitudinal central tongue, D, adapted to enter the groove of its companion superincumbent blocks and bind the blocks together. On the upper side of each block are made grooves E, which extend from the ends of the opening B to the ends of the block, for the purpose to be hereinafter described. The ends of each block are provided with vertical flutes or scallops, F, adapted to fit together when the blocks are arranged end to end.

G represents clamps or keepers, which are preferably made of iron or other suitable metal, and comprise bars *g*, having depending arms

g' at their ends, the said arms being wedge-shaped longitudinally.

The bars are adapted to enter the grooves E of two adjoining blocks, and the arms of the clamps bear against the inner ends of the blocks, thereby locking them firmly together and preventing them from being longitudinally displaced. By reason of the grooves E the clamps are countersunk in the blocks, and are thus prevented from projecting beyond the upper sides thereof.

In erecting a wall the blocks are laid in horizontal courses, care being taken to have the joints in each course midway between the joints of the subjacent course, as shown.

I do not secure the blocks together ordinarily by means of cement or mortar, but prefer to employ strips of tarred paper or canvas coated with any suitable glutinous substance. These strips of tarred paper or canvas are inserted between the joints of the blocks, both at the ends and at the upper and lower sides thereof. The fluted meshed ends of the blocks admit of the paper being inserted between them without being torn, and effect joints which are sufficiently tight to exclude air and light.

By arranging some of the blocks directly over each other in building a wall, so that the interior openings in the blocks will align with each other, a chimney or flue can be formed, as will be readily understood. In this case the fluted ends of the blocks of that portion of the chimney or flue which projects above the roof give a very neat and tidy finish to the chimney.

In order to enable window or door frames to be built into the wall while the latter is being constructed, I provide some of the blocks A, which are to form the sides of the opening in the wall, with vertical rectangular grooves H in one end, the said grooves being adapted to receive and retain the sides of the frame I, as shown at Fig. 4. Those blocks which are to form the lower course of an outside wall just above the floor are made with moldings K on their inner sides, and panels or other ornamental forms, L, below the moldings to form the wash-board, and on their outer sides the said blocks are formed with projecting offsets or shoulders M, having beveled upper sides to form the water-table of the wall.

Patent 7: H. S. Palmer, *Building Blocks*, U. S. Patent No. 384,541, June 12, 1888.

In order to avoid cutting any of the blocks to make all the courses of the wall of equal length, I provide certain blocks, A³, with vertical dovetailed grooves A' on their opposing ends, and further provide space blocks or keys M' of various widths and made of the same material as the blocks. These keys have their side edges beveled and thereby adapted to enter the grooves A' and fill the spaces between the blocks A³, as shown at Fig. 5.

By means of the blocks and devices hereinbefore described walls can be erected very rapidly and without employing the services of skilled masons. Such walls are also absolutely fire and water proof, and are exceedingly strong and durable. Such walls are also adapted to be taken down, when desired, very quickly and easily and without destroying the material.

If it be desired to increase the strength and durability of a wall erected for permanent use, this may be accomplished by omitting the use

of the tarred paper and pouring concrete in a thin and plastic condition into the hollow of the wall, so as to completely fill the same.

Having thus described my invention, I claim--

As a new article of manufacture, a hollow rectangular concrete building-block having the projecting tongue D on its top and the groove C in its lower side, the tongue of one block fitting in the groove of the superimposed block, and the ends of the block being provided with a series of scallops or vertical corrugations extending entirely across the end thereof, substantially as described and shown.

In testimony that I claim the foregoing as my own I have hereto affixed my signature in presence of two witnesses.

HARMON S. PALMER.

Witnesses:

T. T. WILSON,

WM. H. PAYNE.

(No Model.)

J. WINKLER.

STAMPING MACHINE FOR MOLDING ARTIFICIAL STONE.

No. 409,542.

Patented Aug. 20, 1889.

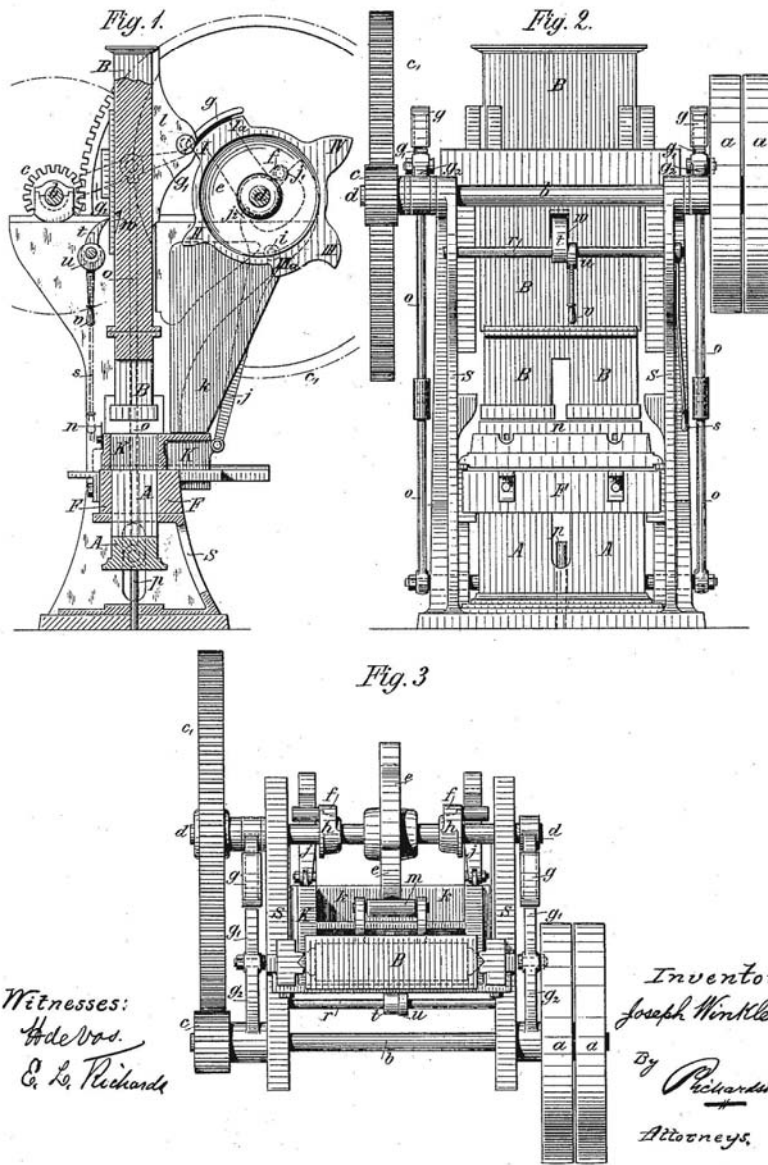

Witnesses:
H. de Vos.
E. L. Richards

Inventor.
Joseph Winkler
By *Richardson*
Attorneys.

Figure 8: J. Winkler, *Stamping Machine for Molding Artificial Stone*, U. S. Patent No. 409,543, Aug. 20, 1889.

UNITED STATES PATENT OFFICE.

JOSEPH WINKLER, OF KIESENBACH, NEAR WALDSHUT, GERMANY.

STAMPING-MACHINE FOR MOLDING ARTIFICIAL STONE.

SPECIFICATION forming part of Letters Patent No. 409,542, dated August 20, 1889.

Application filed July 24, 1888. Serial No. 230,951. (No model.) Patented in Germany July 1, 1887, No. 42,780; in England September 28, 1887, No. 13,133, and in France October 10, 1887, No. 173,413.

To all whom it may concern:

Be it known that I, JOSEPH WINKLER, a subject of the Grand Duke of Baden, residing in Kiesenbach, near Waldshut, in the Grand Duchy of Baden, Germany, have invented certain new and useful Improvements in Stamping or Beating Machines for Molding Artificial Stones and the Like, (for which I have obtained patents as follows: in Germany, No. 42,780, dated July 1, 1887; in France, No. 173,413, dated October 10, 1887, and in England, No. 13,133, dated September 28, 1887,) of which the following is a specification.

My invention relates to a machine for the rapid manufacture of firm well-formed bricks, tiles, briquettes, and other similar articles from cement, slag, coal-dust, and other appropriate materials, and for automatically effecting the requisite operations, such as feeding the material to be operated on into the form-box, compressing said material in the form-box, lifting out and removing the finished bricks, tiles, &c.

Figure 1 is a vertical section of the machine on the line $x x$ in Fig. 3. Fig. 2 is an elevation, and Fig. 3 a top view or plan of my improved machine.

a are the strap-drums arranged on the driving shaft b , and consisting of a fast and loose drum, or the two halves of the shaft can be connected by a claw-coupling.

The pinion c is keyed to the driving-shaft b , and is in gear with the tooth-wheel c' on the shaft d , to which a disk e , with suitable tappets, is fixed, as described later on in this specification. The rollers $f f$ and the preferably T-formed lever-arms $g g$ are also carried by the shaft d , said rollers $f f$ extending horizontally from the disks h and serving for operating the two-armed levers $j j$, which have their fulcrums at $i i$ and which serve to give the charging-box K a horizontal reciprocating movement beneath the drop-hammer B .

The charging-box K feeds the material placed by hand in the hopper k of the same into the form F and above the anvil A .

The anvil A constitutes the bottom of the form, and can be raised and lowered by means

of a device described later on, while the said walls of the form F are fixtures.

Immediately above and fitting snugly into the said form F is the drop-hammer B , which has its guides in the massive standards G , and which is provided at the rear with two lugs $l l$, for carrying the massive roller m , with which the tappets of the tappet-disk e come in contact, so as to raise the said drop-hammer B in its guides. The drop-hammer B gives, preferably, four blows for each operation, the commencement of the operation being represented in Fig. 1, after the charging-box K has fed a fresh quantity of material into the form. The drop-hammer B strikes the first blow as soon as the tip of the tappet I has passed the roller m . During the further rotation of the disk e the tappet II comes into contact with the roller m of the hammer B , raises the same and causes, as before described, the second blow. A further rotation of the said disk e brings the part III^a in gear with the roller m and raises the hammer B , which remains in this position until the tappet III has passed the roller m . At the same time, when the hammer is held up by the concentric part III^a of the tappet III the roller f comes in contact with the claws j^2 and presses the same to the left, so that the charging-box k beneath the hammer B is moved to the rear. The flexible scraper n will now scrape off any material adhering to the striking-surface of the hammer B into the hopper k , and the tappet III now allows the hammer to fall for the third blow, whereupon the said hammer is again raised by the tappet IV and falls to give the fourth blow when the said tappet IV has passed the roller m of the hammer B .

The time used in giving the third and fourth blows is utilized for repelling the charging-box K .

The bricks or other objects, which are completed as soon as the fourth blow has been struck, are lifted out of the form, for which purpose the anvil A can be moved upward by means of two connecting-rods, one on each side of the anvil, said upward movement being effected by the arms $g g$. The connect-

Figure 8: J. Winkler, *Stamping Machine for Molding Artificial Stone*,
U. S. Patent No. 409,543, Aug. 20, 1889.

ing-rod *o* is connected to a lever *g'*, which can be mounted on the shaft *b*, the free end of the said lever *g'* being raised by coming in contact with the edge *l* of the arm *g*. During the further rotation of the disk *e* the anvil *A* remains in its raised position and has pushed the finished brick or other object out of the form. The roller *f* presses simultaneously against the claw *j'* of the lever *j* and pushes the refilled charging-box *K* again under the hammer, thereby pressing the finished brick or other object from the anvil, which recedes to its original position, so that the material in the charging-box *K* falls into the form. The arrangement of the parts is such that the lever-arm *g* will release the lever *g'* before the tappet *I* releases the hammer *B*, in order that the anvil *A* can receive the blow of the same. The anvil is guided by means of one or more mandrels *p*, running in suitable borings in the anvil. The afore-described series of movements are now repeated. The machine as represented in the accompanying drawings is intended for simultaneously making two bricks; but it will be evident that the same can be arranged to make only one or a larger number of bricks, tiles, or other objects.

In order to be able to retain the hammer *B* in raised position, a shaft *r*, which can be rotated by means of the lever *s*, is employed. A pawl *t* is eccentrically mounted on the shaft *r* by means of the eccentric *u*, which can also be operated direct by means of the handle *v*, so as to bring the hammer *B* out of contact with the tappets of the disk *e*.

The pawl *t* gears into a recess *w* of the hammer *B* when the same is to be put out of action. The tappets on the disk *e* are of various heights, so that the successive blows on the mass or material in the form are of increasing force.

Fig. 1 represents the anvil *A* in raised position immediately before the first blow of the

hammer *B* is given. In Fig. 2 the levers *g'* *g*² have been already released from the arms *g*, and the anvil also released, and the hammer is about to give the first blow.

Having now particularly described and ascertained the nature of my said invention and in what manner the same is to be performed, I declare that what I claim is—

1. A machine for manufacturing bricks, tiles, briquettes, and other objects, consisting substantially of the drop-hammer *B*, which is raised by the tappets *I* *II* *III* *IV*, of a disk *e*, the anvil *A*, which is raised by means of the connecting-rods *o*, levers *g'* *g*², and arms *g*, the charging-box *K*, which feeds the material into the form, pushes the formed articles out of the machine, and is operated by the lever *j* with its claws *j'* *j*², and has its fulcrum at *i*, which said lever *j* preferably receives its movement from the roller *f*, arranged crank-like on the shaft *d*, substantially as set forth.

2. In a machine for manufacturing bricks, tiles, and the like, the combination, with the charging-box, the hammer, and means for retaining the hammer temporarily in the raised position, of a series of tappets of gradually-increasing size, whereby the blows of the drop-hammer are successively increased, substantially as and for the purposes set forth.

3. In a machine for manufacturing bricks, tiles, and the like, the arrangement of a pawl *t* on an eccentric *u* on the shaft *r*, which said pawl can be operated by the handle *v* or handle-*lever* *s* for retaining the drop-hammer *B* in its highest position, substantially as set forth and shown on the drawings.

In testimony that I claim the foregoing as my invention I have signed my name in presence of two subscribing witnesses.

JOSEPH WINKLER.

Witnesses:

ALBR. LIEBELT,
JOHANN TEPY.

Figure 8: J. Winkler, *Stamping Machine for Molding Artificial Stone*, U. S. Patent No. 409,543, Aug. 20, 1889.

No. 674,874.

Patented May 28, 1901.

H. S. PALMER.
CONCRETE WALL FOR BUILDINGS.

(Application filed Mar. 21, 1900.)

(No Model.)

2 Sheets—Sheet 1.

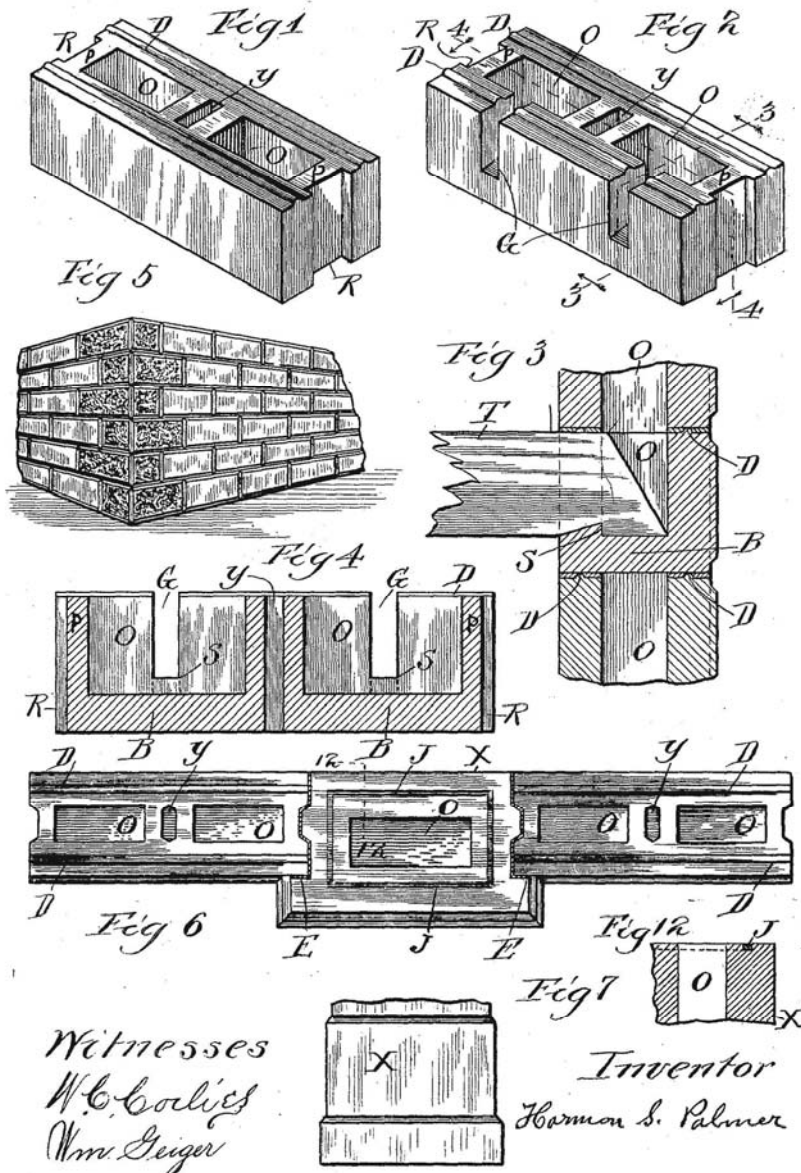

THE NORRIS PETERS CO. PHOTO-LITHO. WASHINGTON, D. C.

Patent 9: H. S. Palmer, *Concrete Wall For Buildings*, U. S. Patent No. 674, 874, May 28, 1901.

UNITED STATES PATENT OFFICE.

HARMON S. PALMER, OF CHICAGO, ILLINOIS.

CONCRETE WALL FOR BUILDINGS.

SPECIFICATION forming part of Letters Patent No. 674,874, dated May 28, 1901.

Application filed March 21, 1900. Serial No. 9,631. (No model.)

To all whom it may concern:

Be it known that I, HARMON S. PALMER, a citizen of the United States, residing at Chicago, in the county of Cook and State of Illinois, have invented certain new and useful Improvements in Concrete Walls for Buildings, of which the following is a specification.

My improvement relates to the construction of buildings; and the object is to simplify, cheapen, and to produce stronger buildings as well as more efficient in protecting from the elements, and relates to that class usually made of concrete or similar material in which separate blocks are united to make the desired wall.

With this end in view my invention consists in certain features of construction and combination of parts, as will be hereinafter set forth, and pointed out in the claims.

In the accompanying drawings, which form part of this specification, Figure 1 is a perspective view of one of my building-blocks designed to be laid with others in position to form the whole and complete wall. Fig. 2 is a similar block, but provided with the openings to receive the floor-joists and a bottom on which the joists rest. Fig. 3 is a detailed vertical section taken through the line 3 3 of Fig. 2, but showing the floor-joists in position. Fig. 4 is a longitudinal section taken on the line 4 4, Fig. 2, but with the joists removed. Fig. 5 is the perspective view of the outside corner of a completed wall. Fig. 6 is a detailed plan view showing the building-blocks as applied to a chimney or pilaster. Fig. 7 is a detailed elevation of a pilaster or chimney removed. Fig. 8 is a detailed perspective view of one of the corner-blocks as shown in Fig. 9. Fig. 9 is a perspective detail view with the several blocks and parts assembled, showing the relation that each bears to the other. Fig. 10 shows a modified form of the door or window frame which is shown in Fig. 9, and the same may be made of wood in place of stone or concrete. Fig. 11 shows a modified form of building these walls with one side concrete and the other side of brick or other material, which is done by splitting the block, Fig. 1, and substituting for the discarded side some other material. Fig. 12 is a cross-section of Fig. 6 on the line 12 12.

In all buildings constructed of soft and por-

ous material—such as brick, sandstone, &c.—a great detriment exists in the absorbent nature of the material and the long time required to dry out such walls after heavy rains, and the unsanitary, damp, and musty condition of such walls after years of service renders any method to prevent or better such conditions valuable. In my method advantage is taken of a cavity or opening O, molded vertically through the concrete block a few inches from the side which forms the outside of the building. By this means a thin wall of stone is made to receive the rain and dampness which is prevented from penetrating to the inside by this opening O, and thus it will be understood that a few hours of sunshine will remove all dampness, leaving the walls dry and the building in a sanitary and healthy condition, and as a further aid to this end this opening O may be used as a ventilator, which can be connected with every room in the house, thereby securing a circulation of air of the most desirable kind. In order to prevent the dampness and frost from penetrating at the joints where the ends of the blocks come together, I set the end partitions (marked P, Fig. 1) a little back from the end of the block, thus leaving an opening R corresponding in purpose to the opening O and intermediate opening Y. When two blocks are joined together thus, a continuous joint is obviated and the object is secured. This is shown at N in Fig. 9. In the use of such hollow walls it is desirable to distribute the minimum amount of material in such a manner as to secure the greatest strength where it is most needed in the building, and as that part of the wall which supports the joists and floors is in need of more strength than other parts I use a course of blocks around the building especially adapted for this purpose. (Represented by Fig. 2.) By reference to the cross-section of this block, Fig. 3, on the line 3 3, it will be seen that the opening O does not extend entirely through the block, and thus is left a solid bottom, (marked B,) the object of which is to, first, give additional strength to resist lateral pressure of the wall, and, second, to make a firm and substantial seat for the joists which support the floors, &c. It will be seen that this block, Fig. 2, is provided with side openings (marked

Patent 9: H. S. Palmer, Concrete Wall For Buildings, U. S. Patent No. 674, 874, May 28, 1901.

G) extending to the central opening O, and these are receptacles to receive and hold the joists or bond-timber, (marked T in Figs. 3 and 9.) By forming the lower ends of these receptacles in the manner shown a shoulder is left on the inside of the opening O, as shown by the letter S in Figs. 3 and 4, and the object of this shoulder is to enter a corresponding notch cut into the joists or bond-timber, as shown by the letter S, Fig. 3, and is for the purpose of tying and binding the walls firmly together. By the use of this particular block three important results are attained—viz., first, the means by which the joists bind the walls together; second, greatly increased strength under the joists which have to support the floors, &c., and, third, a long and perfect seat on which the joists rest. In order to strengthen the building still more, a block especially adapted to form the corner is shown by Fig. 8. Two desirable advantages are gained by the use of this block, which has an inner angle, as shown at A in Figs. 8 and 9—first, a corner of the building is secured without a single joint, which is a most desirable feature; but the second advantage is the means by which a perfect bond of the different courses of the blocks is preserved, as shown in Fig. 5. If the blocks of the side walls came through at the corners, as heretofore, the joints thus occasioned would not come in the center of the long blocks, thus destroying the perfect bond and harmony of the ashlar; but with a block containing an inner angle, as shown by the letter A in Figs. 8 and 9, the bond and harmony, perfectly retained and combined with the increased strength, are valuable. As a further means to secure the greatest strength with a minimum amount of material I provide a raised projection or longitudinal bead, molded lengthwise on the stone, as shown at D in nearly all the figures. By the use of this bead the bearings are always in the center of the stone, which is the strongest part, as shown more particularly at D, Fig. 3. It is also a gage by which to spread the thickness of the mortar as the blocks are laid in the wall, thus giving a true and even bearing and materially adding to the strength of the wall when the mortar is dry and hard.

In Fig. 6 is shown a section of blocks (marked X) of a different shape from and for a different purpose than any of the others. These sections of blocks are built into the walls wherever desired to secure the results and are for one or more of the following purposes: as a chimney for conducting smoke, as a pilaster for giving strength, and as a means for preventing vertical cracks in the walls. It will be understood that while heat is conducted when used as a chimney the change of temperature is liable to expand and contract the material of which the wall is composed, sometimes causing harmless, but unsightly, cracks to appear if the walls are long and unbroken, and to prevent this advantage is taken at this point

to form a "sliding joint," which will allow of expansion and contraction without pulling the blocks apart to cause the crack. It will be seen by reference to the letters E E, Fig. 6, that these joints are in the nature of a mortise and tenon, and while they allow for expansion and contraction will not produce an unsightly crack. It should be understood that these sections can be used for this purpose alone when no chimney or pilaster is required, in which case shorter sections of different designs on the outside can be arranged with the sliding joint, as shown at E E, Fig. 6. It will be observed that in nearly all these blocks there are two large openings (marked O) and an intermediate opening (marked Y) which corresponds in size and shape to an opening formed by uniting the ends of two other blocks having the opening marked R. By this means the builder is enabled to keep these openings in alignment one above the other, thus giving more perfect ventilation and also allowing the air to pass that course of blocks which have the bottom to support the joist, as shown at Y in Fig. 4.

When absolutely fireproof buildings are to be constructed by this method, it should be understood that the wooden joists can be dispensed with and in their place iron or steel beams be used; but the general construction of tying the walls and supporting these beams is the same, also in regard to the door and window frames, of which both wood and stone or metal can be used, as desired, the construction of both wood and stone being shown by Fig. 10.

In Fig. 9 is shown a section of frame made of artificial stone or concrete C C, resting on the door-sill. In this way the frame can be put up in sections as the wall is laid or in one piece, as desired; but in either case the projecting lug C² is made to enter the opening of the block marked R, thus making a perfectly water-tight joint at this point all around the frame. The rabbet or offset on the inside of this frame (shown by the letter F) is for the same purpose when a metal sash is used.

When from any cause it is desired to use a wooden frame, I construct them, as shown by Fig. 10, with the front casing H in one piece and forming a part of the projecting lug C², Fig. 9. By this means it will be seen that as this part sets back into the opening R (represented at C, Fig. 9) a crack or joint is obviated. The shown in Fig. 10 (marked K) is for cords and window-weights.

In Fig. 9 the different blocks are assembled in the wall to form a building possessing the merits which I claim in the foregoing specification. Beginning with the lower course of blocks at the right in Fig. 9, I use the blocks shown by Fig. 1, joining the ends, as shown at N. A continuous joint is obviated, and the shape and size of the opening thus made are the same as the intermediate opening Y. When the corner is reached, the block repre-

674,874

3

sented by Fig. 8 is placed in position, with the short side (which is a half-block) to the left, and to this is joined another whole block, as shown by Fig. 1, and to this is attached the frame, as before described. Returning to the corner, I reverse the corner-block and put the short side to the right, thus making a perfect bond and all openings in alinement one above the other. When the desired height is attained for the floors or bond-timbers, the block shown by Fig. 2 is placed in position around the building, the joists are notched and fitted and placed in the gains G, and the next course of blocks, Fig. 1, is laid over the joists, and so on to the roof.

While only right angles are above referred to, it will be understood that any other angle can be made in the same way and for the same purpose.

In Fig. 11 is shown a modified form in which these walls can be constructed combined with brick or similar material. By dividing the blocks represented by Fig. 1 on the line 4 4, Fig. 2, I have one side of the block W provided with the cross-partitions P P. By these cross-partitions the other side, made of brick or other material L, may be united to the concrete side W, thus preserving the opening O substantially as though both sides were made of concrete and either side may be the outside of the building.

In Fig. 6 (letters) J J is shown an iron band which is sometimes embedded in the concrete block when the same is molded and is for the purpose of strengthening and preventing the blocks from cracking when extra or unusual weight or stress is brought to bear upon them. This can also be put in any of the other blocks and is designed to be a continuous band, strengthening the ends as well as the sides. In Fig. 12, which is a cross-section of Fig. 6 on the line 12 12, this band is at the top of the block, but may be in the middle or where desired.

Having thus described my invention, what

I claim as new, and desire to secure by Letters Patent, is—

1. The within-described building-wall constructed of hollow concrete blocks, and containing the corner-block with the inner angle as shown at A in Figs. 8 and 9, and opening O for the purpose as shown and described.

2. The within-described building-wall constructed of hollow concrete blocks, containing the block Fig. 2, provided with the bottom B substantially as specified.

3. The within-described building-wall constructed of hollow concrete blocks, one or more sections connected by an exterior lap projecting from one of the adjacent pairs as shown at E for the purpose of hiding exteriorly the crack caused by expansion and contraction of the material employed, substantially as and for the purpose set forth.

4. The above-described building-wall constructed of hollow concrete blocks shown by Figs. 1, 2, 6, and 8, all combined substantially as and for the purpose herein shown and described.

5. The within-described building-wall constructed of hollow concrete blocks, in combination with a wooden frame containing the cavity K, and the casing H forming a part of the projecting lug C², as shown in Fig. 9, all combined substantially as set forth.

6. The within-described hollow building-wall consisting of one concrete side W (Fig. 11) provided with the cross-partitions P P by which is connected the opposite side L made of brick or other material, so as to leave an air-space O, substantially as set forth.

7. The within-described building-wall constructed of hollow concrete blocks, said blocks containing a band of metal embedded therein as shown by the letters J J Fig. 6, as set forth.

HARMON S. PALMER.

Witnesses:

DUNCAN M. MOORE,
LOUIS B. DORR.

No. 694,985.

Patented Mar. 11, 1902.

N. F. PALMER.
MACHINE FOR MOLDING ARTIFICIAL STONE.

(Application filed Sept. 28, 1901.)

(No Model.)

2 Sheets—Sheet 1.

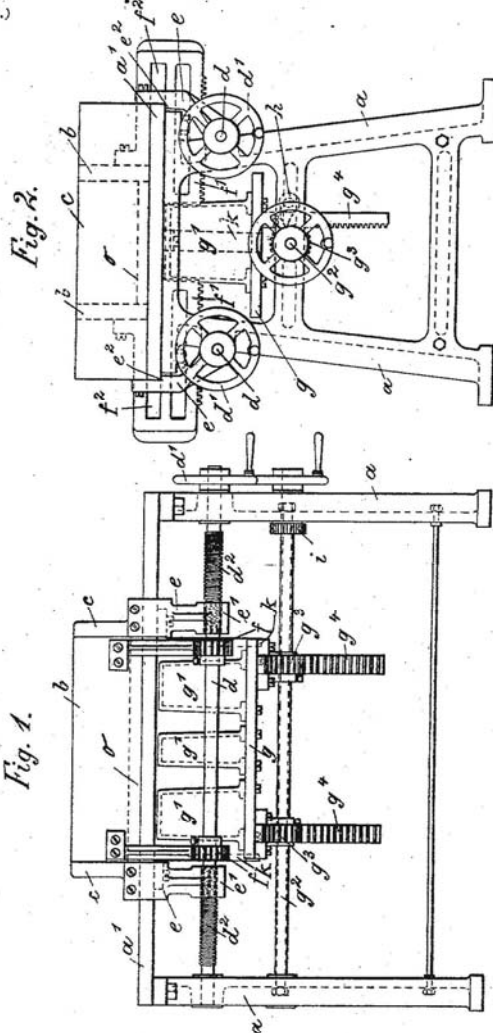

Witnesses:
Arthur Lumpe
Edward Gray

Inventor:
Noyes F. Palmer
 by his attorneys
Coeders & Sires

THE MORRIS PETERS CO., PHOTO-LITHO., WASHINGTON, D. C.

Patent 10: N. F. Palmer, *Machine for Molding Artificial Stone*,
 U. S. Patent No. 694,985, Mar. 11, 1902.

No. 694,985.

Patented Mar. 11, 1902.

N. F. PALMER.

MACHINE FOR MOLDING ARTIFICIAL STONE.

(Application filed Sept. 28, 1901.)

(No Model.)

2 Sheets—Sheet 2.

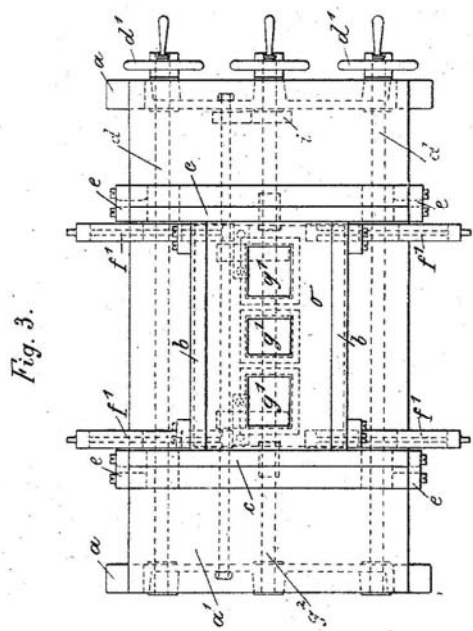
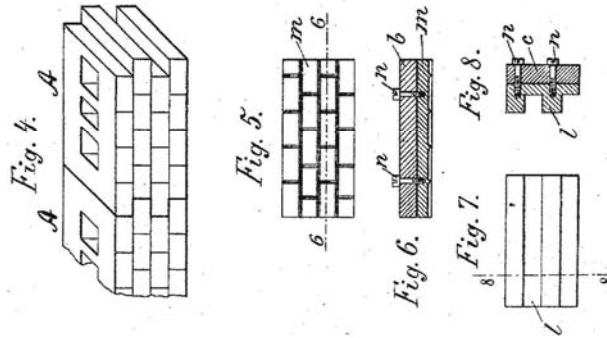

Witnesses:
Arthur L. Lumm
Edward Ray

Inventor:
Noyes F. Palmer
 by his attorney
Walter A. Brown

THE MORRIS PETERS CO., PHOTO-LITHO, WASHINGTON, D. C.

Patent 10: N. F. Palmer, *Machine for Molding Artificial Stone*,
 U. S. Patent No. 694,985, Mar. 11, 1902.

UNITED STATES PATENT OFFICE.

NOYES F. PALMER, OF BROOKLYN, NEW YORK.

MACHINE FOR MOLDING ARTIFICIAL STONE.

SPECIFICATION forming part of Letters Patent No. 694,985, dated March 11, 1902.

Application filed September 23, 1901. Serial No. 76,852. (No model.)

To all whom it may concern:

Be it known that I, NOYES F. PALMER, a citizen of the United States, and a resident of Brooklyn, county of Kings, and State of New York, have invented certain new and useful Improvements in Machines for Molding Artificial Stone, of which the following is a specification.

This invention relates to a machine for molding hollow and solid concrete building and paving blocks.

The machine is provided with a mold-box having sliding sides and ends that are simultaneously moved inward or outward. The mechanism for effecting this movement is such that the machine may be readily set to mold blocks of various sizes.

In the accompanying drawings, Figure 1 is a side elevation of my improved machine; Fig. 2, an end elevation thereof; Fig. 3, a plan; Fig. 4, a perspective view showing adjoining blocks molded by the machine; Fig. 5, a face view of one of the removable pattern-plates *m*; Fig. 6, a section through the mold-box on line 6-6, Fig. 5; Fig. 7, a face view of the removable pattern-plate *l*; and Fig. 8, a section through the mold on line 8-8, Fig. 7.

The letter *a* represents the frame of the machine supporting the bed-plate *a'*. The mold-box is formed of two side plates *b* and of two end plates *c*, arranged to slide upon the bed-plate. The plates *b* are movable between the plates *c*, the latter being of a length to extend along the entire path of plates *b*. Motion is imparted simultaneously to all the plates *b* and *c*, so as to open or close the mold-box, in the following manner:

d d are a pair of longitudinal shafts supported in frame *a* and which may be either intergeared or be separately driven by hand-wheels *d'* or otherwise. Each shaft is provided with a right and a left worm *d²*, engaged by nuts *e'* of arms *e*, to which the end plates *c* are connected. These arms are provided with offsets *e²*, engaging the lower face of bed-plate *a'* and constituting guides. Between the worms *d²* there are bolted to each of the shafts *d* a pair of gear-wheels *f*. These wheels are engaged by racks *f'*, extending transversely to the shafts *d*. The racks *f'* are slot-

ted, as at *f²*, to embrace the bed-plate *a'* and are connected at their upper ends to the side plates *b*. The slots *f²* constitute guides for the movement of the racks and side plates. It is evident that by rotating the shafts *d* all the four sides of the mold will slide either outward or inward, so that the mold will open or close. Should it be desired to change the size of the mold-box, the gear-wheels *f* are unbolted from shafts *d* and slipped out of engagement with the racks *f'*. By turning the shafts *d* the position of the arms *e* and end plates *c* may be readily shifted, while by drawing the racks *f'* in or out and then resetting the wheels *f* the position of the side plates *b* may also be shifted. Thus the machine may be readily set to mold larger or smaller blocks. When the size of the mold-box is changed, the same end plates *c* may be retained, while the side plates must obviously be removed and replaced by others of the size desired.

In order to make hollow blocks, I provide a plunger *g*, carrying a core or set of cores *g'*, corresponding in size and position to the perforations to be formed within the blocks *A*. The cores *g'* may be projected into the mold-box through perforations *a²*, formed in the bed-plate *a'*. The plunger is operated from a longitudinal shaft *g²*, having pinions *g³*, which are engaged by racks *g⁴*, depending from plunger *g* and held against the pinions by idlers *h*. A pawl and ratchet *i* maintains the plunger at any elevation, while it is guided in its movements by suitable rails *k*.

To the inner side of the mold-box are adapted to be removably secured pattern-plates, by which any suitable shape may be given to the ends or face of the block. Thus when the ends are to be made in the form of tongues and grooves I use pattern-plates *l*, of the shape illustrated in Figs. 7 and 8. So, also, when the face of the block is to be provided with creases to imitate courses of bricks I use the pattern-plate *m*. (Illustrated in Figs. 5 and 6.) These pattern-plates are so attached to the side and end plates of the mold by bolts *n* or otherwise that they may be readily removed or replaced.

In use the mold-box is set to the size required, a false bottom *o* is inserted, and the

Patent 10: N. F. Palmer, *Machine for Molding Artificial Stone*, U. S. Patent No. 694,985, Mar. 11, 1902.

2

694,985

core is raised. The stuff is then tamped in and struck off, after which the mold is opened and the block lifted out upon the false bottom.

It will be seen that by my invention blocks of various sizes and contours may be quickly molded by one and the same machine. By sliding the sides outward the pattern-plates are withdrawn from the molded faces of the blocks in a rectilinear direction, so that tongues, grooves, or other deep surface configurations may be readily produced.

What I claim is—

1. In a machine for molding artificial stone, the combination of a mold-box having sliding sides, and an open bottom, with a vertically-movable core adapted to be projected through said bottom, substantially as specified.

2. In a machine for molding artificial stone, the combination of a mold-box having sliding sides and sliding ends, with a worm-shaft adapted to actuate the sliding ends, and with racks and pinions adapted to actuate the sliding sides, substantially as specified.

3. In a machine for molding artificial stone, the combination of sliding mold-box sides, with sliding mold-box ends which project beyond the mold-box sides, and with means for simultaneously moving the sides and ends, substantially as specified.

4. In a machine for molding artificial stone, the combination of a shaft having right and left worms and a pair of pinions mounted upon the shaft between the worms, with a mold-box having sliding ends adapted to be operated by the worms, and sliding sides

adapted to be operated by the pinions, substantially as specified.

5. In a machine for molding artificial stone, the combination of a shaft having right and left worms, and a pair of pinions movably bolted upon the shaft between the worms, with threaded arms engaging the worms, mold-box ends connected to the arms, racks engaging the pinions, and mold-box sides connected to the racks, substantially as specified.

6. In a machine for molding artificial stone, the combination of a mold-box having sliding ends and sliding sides, with worms and pinions for actuating the same, a vertically-movable core, and means for raising and lowering said core, substantially as specified.

7. In a machine for molding artificial stone, the combination of a mold-box having sliding sides and ends, with pattern-plates adapted to be removably attached to the mold-box, substantially as specified.

8. In a machine for molding artificial stone, the combination of a mold-box having sliding sides and ends, with pattern-plates adapted to be removably attached to the mold-box, and with a core adapted to be projected into the mold-box, substantially as specified.

Signed by me at New York city, county and State of New York, this 27th day of September, 1901.

NOYES F. PALMER.

Witnesses:

F. V. BRIESEN,
EDWARD RAY.

Patent 10: N. F. Palmer, *Machine for Molding Artificial Stone*, U. S. Patent No. 694,985, Mar. 11, 1902.

No. 731,323.

PATENTED JUNE 16, 1903.

H. S. PALMER.

MACHINE FOR MOLDING HOLLOW CONCRETE BUILDING BLOCKS.

APPLICATION FILED APR. 9, 1903.

NO MODEL.

7 SHEETS—SHEET 1.

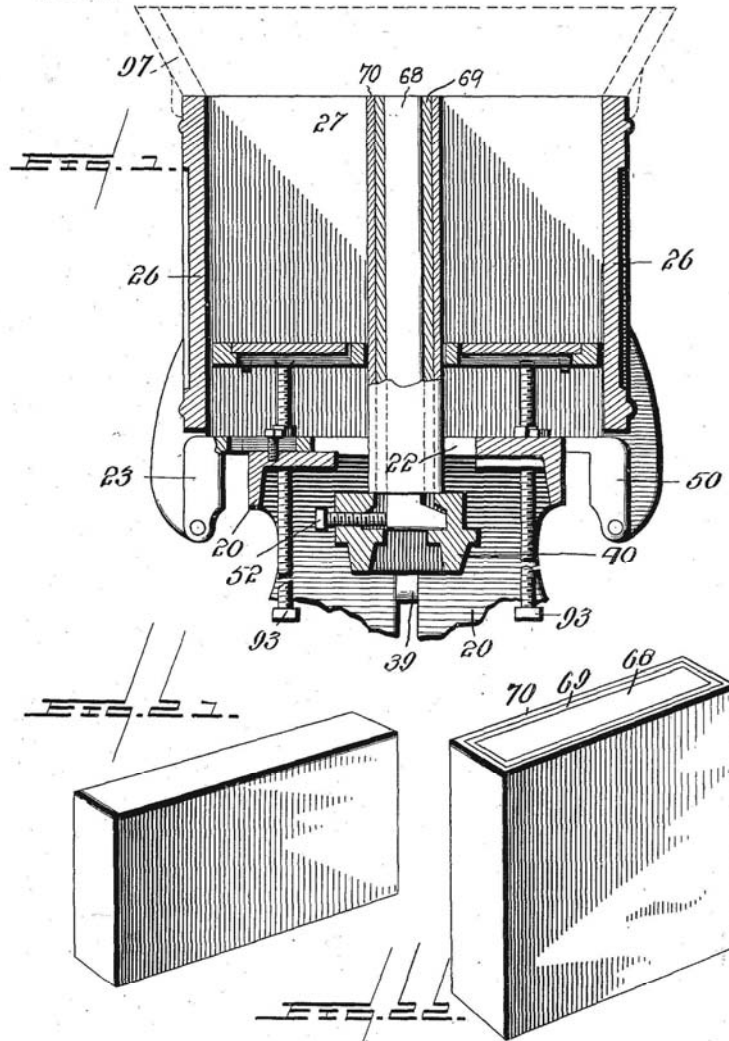

Witnesses
H. S. Palmer
J. M. & C. Palmer

H. S. Palmer, Inventor.
by *C. Knowles*
Attorneys.

THE MORRIS PETERS CO. PHOTO-LITHO., WASHINGTON, D. C.

Patent 11: H. S. Palmer, *Machine for Molding Hollow Concrete Building Blocks*, U. S. Patent No. 731,323, June 16, 1903.

No. 731,323.

PATENTED JUNE 16, 1903.

H. S. PALMER.

MACHINE FOR MOLDING HOLLOW CONCRETE BUILDING BLOCKS.

APPLICATION FILED APR. 9, 1903.

NO MODEL.

7 SHEETS—SHEET 2.

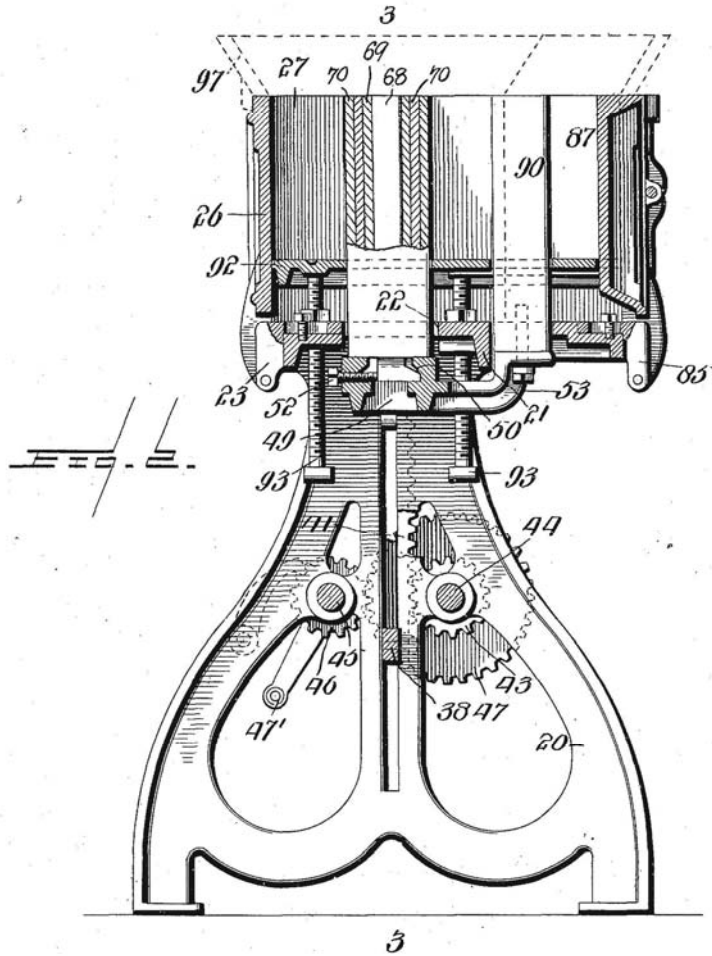

Witnesses
W. F. Doyle
J. M. & J. S. Parker

H. S. Palmer, Inventor.
 by *C. Knowles*
 Attorneys

THE AMERI PETERS CO. PHOTO LITHO. WASHINGTON, D. C.

Patent 11: H. S. Palmer, *Machine for Molding Hollow Concrete Building Blocks*, U. S. Patent No. 731,323, June 16, 1903.

No. 731,323.

PATENTED JUNE 16, 1903.

H. S. PALMER.

MACHINE FOR MOLDING HOLLOW CONCRETE BUILDING BLOCKS.

APPLICATION FILED APR. 9, 1903.

NO MODEL.

7 SHEETS—SHEET 3.

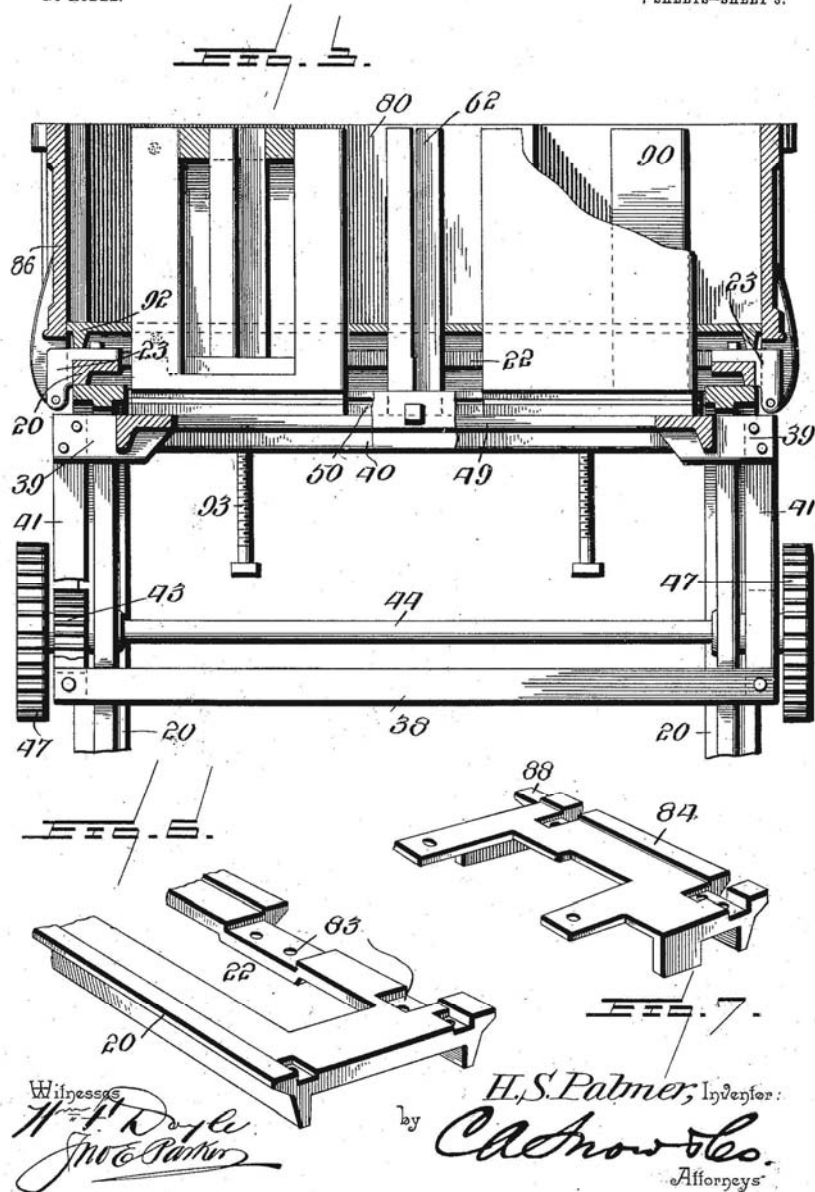

Witnesses
H. F. Doyle
J. W. Palmer

H. S. Palmer, Inventor.
by *C. A. Knowles*
Attorneys

THE MORRIS PETERS CO., PHOTO-LITHO., WASHINGTON, D. C.

Patent 11: H. S. Palmer, *Machine for Molding Hollow Concrete Building Blocks*, U. S. Patent No. 731,323, June 16, 1903.

No. 731,323.

PATENTED JUNE 16, 1903.

H. S. PALMER.

MACHINE FOR MOLDING HOLLOW CONCRETE BUILDING BLOCKS.

APPLICATION FILED APR. 9, 1903.

NO MODEL.

7 SHEETS—SHEET 4.

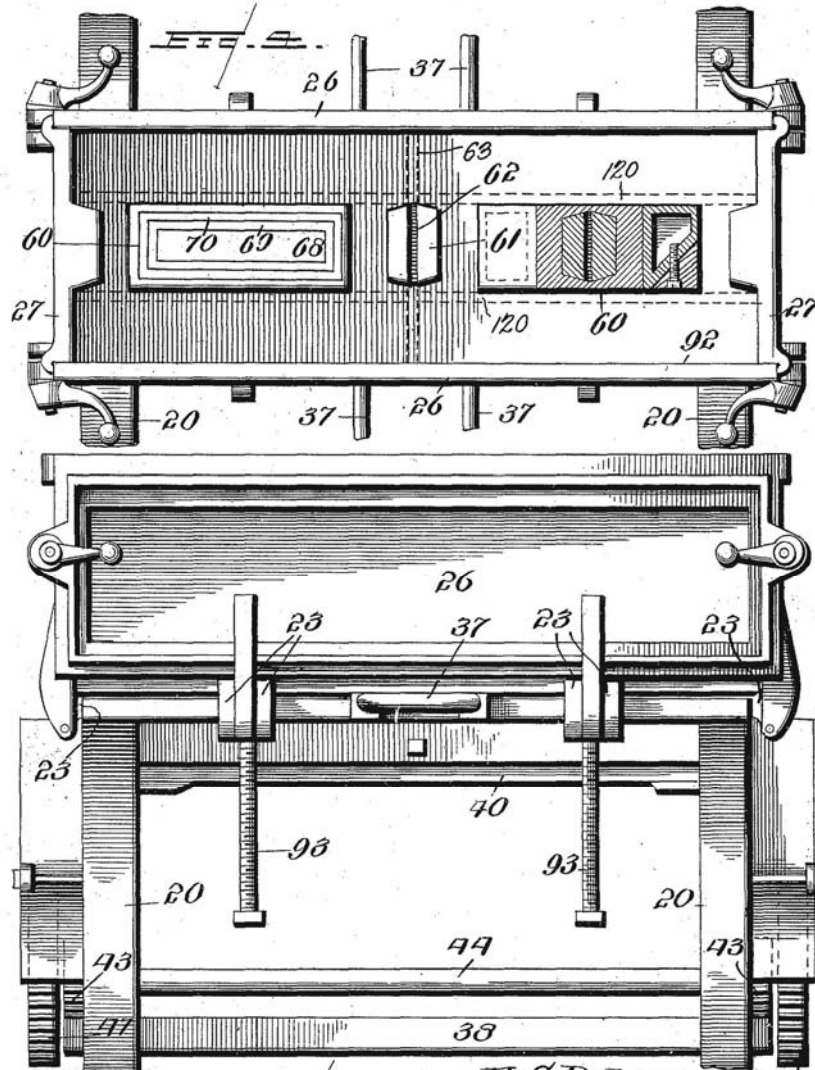

Witnesses
Wm. H. Taylor
Jno. C. Parker
by *H. S. Palmer*, Inventor
C. Snow & Co.
Attorneys

THE HOBBS PETERS CO., PHOTO-LITHO., WASHINGTON, D. C.

Patent 11: H. S. Palmer, *Machine for Molding Hollow Concrete Building Blocks*, U. S. Patent No. 731,323, June 16, 1903.

No. 731,323.

PATENTED JUNE 16, 1903.

H. S. PALMER.
MACHINE FOR MOLDING HOLLOW CONCRETE BUILDING BLOCKS.

APPLICATION FILED APR. 9, 1903.

NO MODEL.

7 SHEETS—SHEET 5.

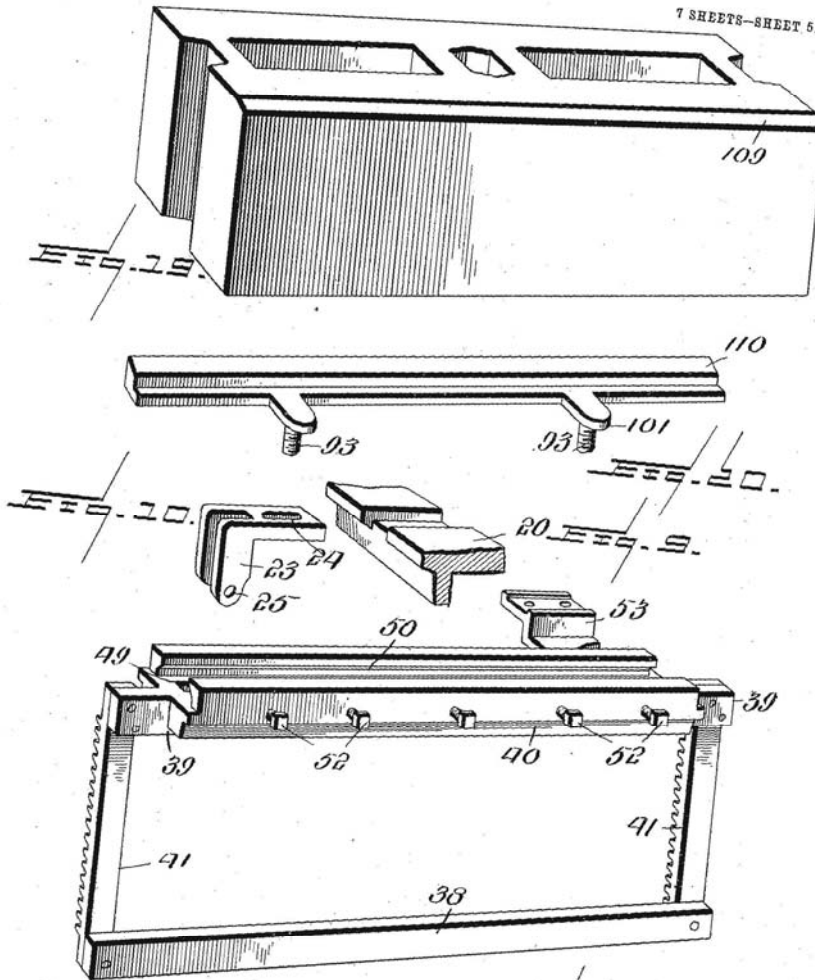

Witnesses
F. Doyle
Wm. C. Palmer

FIG. 1.
H. S. Palmer, Inventor.
Chas. Knowlton
Attorneys

THE MORRIS PETERS CO., PHOTOLITHO., WASHINGTON, D. C.

Patent 11: H. S. Palmer, *Machine for Molding Hollow Concrete Building Blocks*, U. S. Patent No. 731,323, June 16, 1903.

No. 731,323.

PATENTED JUNE 16, 1903.

H. S. PALMER.

MACHINE FOR MOLDING HOLLOW CONCRETE BUILDING BLOCKS.

APPLICATION FILED APR. 9, 1903.

NO MODEL.

7 SHEETS—SHEET 6.

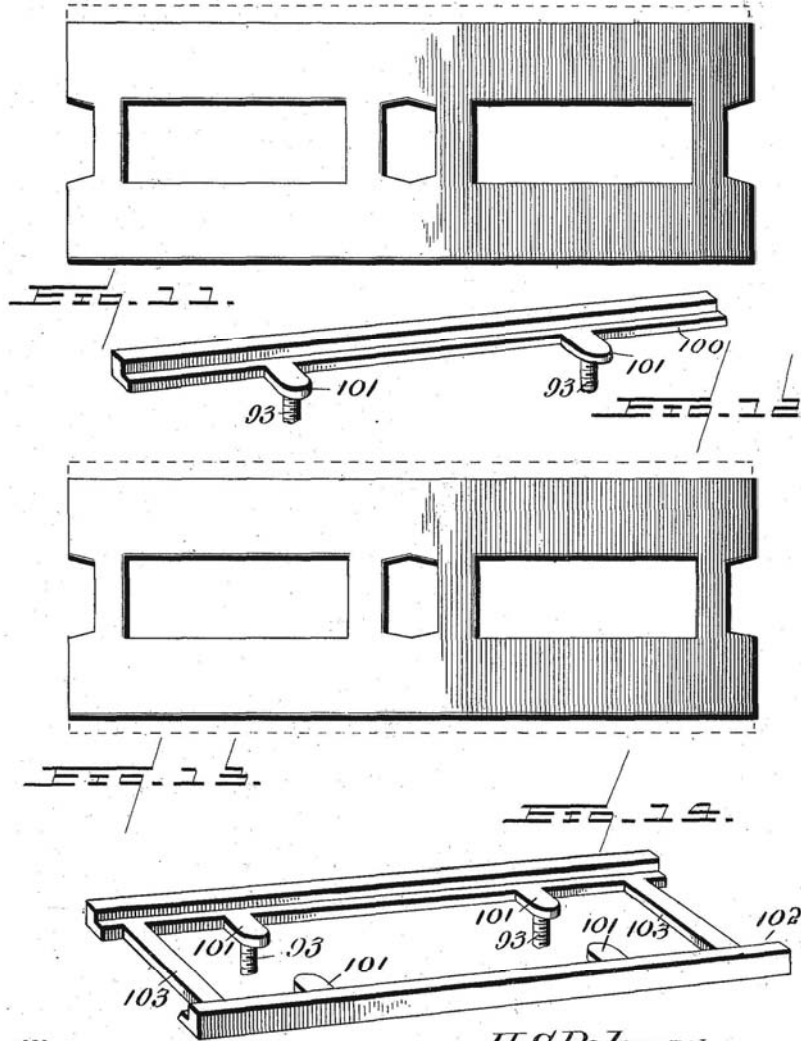

Witnesses
W. F. Doyle
J. C. Palmer

H. S. Palmer, Inventor:
by *C. Snowles*
Attorneys

THE MORRIS PETERS CO., PHOTO-LITHO., WASHINGTON, D. C.

Patent 11: H. S. Palmer, *Machine for Molding Hollow Concrete Building Blocks*, U. S. Patent No. 731,323, June 16, 1903.

No. 731,323.

PATENTED JUNE 16, 1903.

H. S. PALMER.

MACHINE FOR MOLDING HOLLOW CONCRETE BUILDING BLOCKS.

APPLICATION FILED APR. 9, 1903.

NO MODEL.

7 SHEETS—SHEET 7.

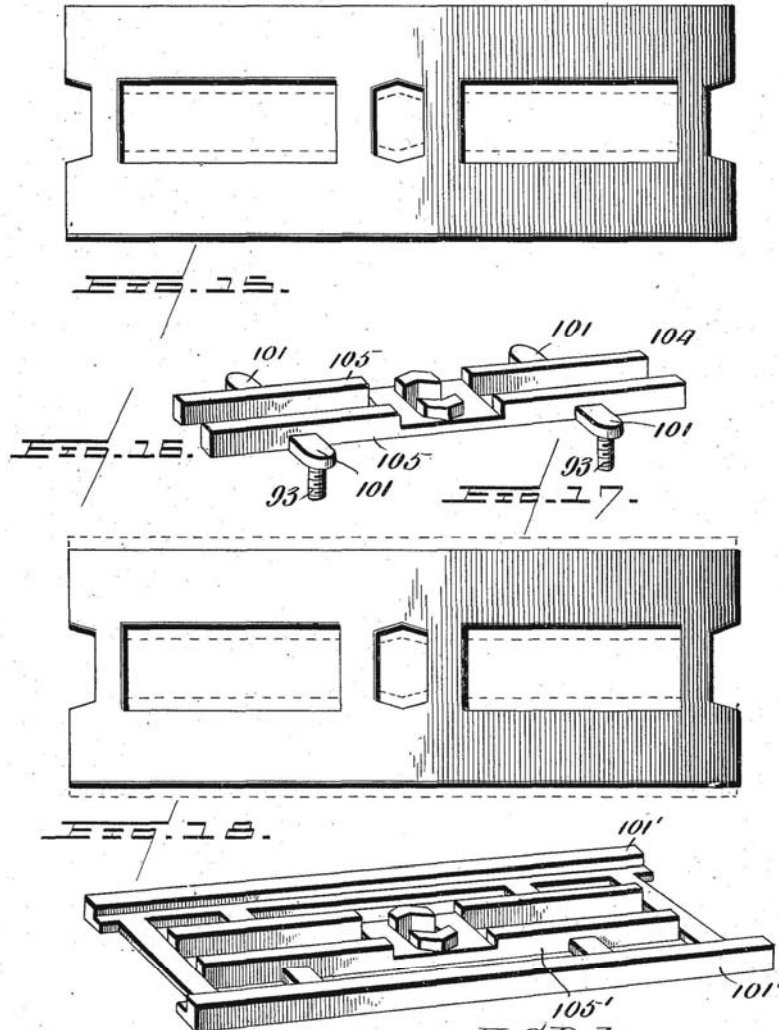

Witnesses
W. F. Doyle
Jno E. Carter

H. S. Palmer, Inventor:
by *C. Knowles*
Attorneys

THE MORRIS PETERS CO., PHOTOLITHO., WASHINGTON, D. C.

Patent 11: H. S. Palmer, *Machine for Molding Hollow Concrete Building Blocks*, U. S. Patent No. 731,323, June 16, 1903.

No. 731,323.

Patented June 16, 1903.

UNITED STATES PATENT OFFICE.

HARMON S. PALMER, OF WASHINGTON, DISTRICT OF COLUMBIA.

MACHINE FOR MOLDING HOLLOW CONCRETE BUILDING-BLOCKS.

SPECIFICATION forming part of Letters Patent No. 731,323, dated June 16, 1903.

Application filed April 9, 1903. Serial No. 151,888. (No model.)

To all whom it may concern:

Be it known that I, HARMON S. PALMER, a citizen of the United States, residing at Washington, in the District of Columbia, have invented a new and useful Machine for Molding Hollow Concrete Building-Blocks, of which the following is a specification.

This invention relates to certain improvements in machines of that class employed for the molding of building-blocks from concrete and similar compositions, and has for its principal object to construct an improved machine by which blocks of any shape and size may be made by proper adjustment of the sides and ends, cores, and other portions of the machine.

A further and important object of the invention is to provide a machine of this class in which a plurality of cores are arranged on a vertically-movable core-carrier in such manner as to permit the ready detachment of the cores and the substitution of others of different shape and size for the formation of core-openings of different character in the blocks, and, further, to provide for the adjustment of the positions of the cores with respect to the length of the block.

In machines employed for the manufacture of building-blocks from concrete and similar compositions it is usual to place in the bottom of the mold-box a removable plate which forms the lower portion of the mold and is removed with the block on the completion of the molding operation to serve as a support for the block until the latter is set or dried to an extent sufficient to permit the removal of the plate without injury to the block. The mold-boxes are adjustable to permit the manufacture of blocks of different shape and size with a single machine, and in such cases it is necessary to employ removable bottom plates of a different size for each different block to be made. This adds greatly to the expense of the machine, as it is necessary to employ hundreds of bottom plates of each size and shape, a block requiring considerable time before it is set to an extent sufficient to permit the removal of the bottom plate and its return to the machine for another operation.

A further object of the invention, therefore, is to provide a machine whereby a single set of bottom plates all of the same size

may be employed in the manufacture of blocks of any shape and size within the limits of the machine.

A still further object of the invention is to provide a machine which may be employed for the manufacture of cored blocks of the usual type or for the manufacture of slabs to be utilized for facing walls or for flooring or like purposes.

A still further object of the invention is to improve the construction of the machine, especially to improve the mounting of the adjustable side and end plates with a view of preventing injury to the blocks during the opening of the mold-box.

With these and other objects in view the invention consists in the novel construction and arrangement of parts hereinafter described, illustrated in the accompanying drawings, and particularly pointed out in the appended claims, it being understood that various changes in the form, proportions, size, and minor details of the structure may be made without departing from the spirit or sacrificing any of the advantages of the invention.

In the accompanying drawings, Figure 1 is a transverse sectional elevation of a machine for molding concrete building-blocks constructed in accordance with the invention. Fig. 2 is a similar view of the same machine on a somewhat smaller scale, illustrating the adjustment of the parts for the manufacture of corner-blocks. Fig. 3 is a longitudinal sectional elevation of the same on the line 3-3 of Fig. 2. Fig. 4 is a plan view of the machine, showing the same adjusted for the manufacture of standard blocks. Fig. 5 is a side elevation of the machine. Fig. 6 is a detail perspective view of a portion of the bed-plate of the machine. Fig. 7 is a similar view of a detachable bracket which may be employed when the machine is adjusted to position for the manufacture of corner-blocks. Fig. 8 is a detail perspective view of the core-carrier removed from the machine. Fig. 9 is a fragmentary view of the bed-plate; and Fig. 10 is a detail perspective view of one of the adjustable lugs employed for the support of the side and end plates, these lugs being arranged at intervals in suitable slots formed at the edge of the bed-plate. Fig. 11 is a plan view of a standard form of block having cores and

Patent 11: H. S. Palmer, *Machine for Molding Hollow Concrete Building Blocks*, U. S. Patent No. 731,323, June 16, 1903.

provided with bonding-recesses at its opposite ends, the dotted lines indicating a block of increased width which may be manufactured by adjusting one of the side plates of the machine. Fig. 12 is a detail perspective view of a removable filling-strip which may be employed as an auxiliary to the movable bottom plate when used in the manufacture of a block of increased width. Fig. 13 is a plan view of a standard block, illustrating in dotted lines an increase in width on both sides of the block, this being secured by adjustment of both of the side plates. Fig. 14 is a detail perspective view of a pair of removable auxiliary strips to be used to increase the effective width of the removable bottom plate when the machine is employed for the manufacture of a block of the size indicated by dotted lines in Fig. 12. Fig. 15 is a plan view of a standard block, showing in dotted lines an increase in the thickness of the walls of the block by decreasing the width of the cores. Fig. 16 is a detail perspective view of a removable bar or strip which may be employed as an auxiliary to the removable bottom plate when a block of the character shown by dotted lines in Fig. 15 is to be made. Fig. 17 is a plan view of a standard block, showing in dotted lines a block of increased width and in which the thickness of the walls is increased by reduction in the area of the cores. Fig. 18 is a detail perspective view of the auxiliary member to be employed as an addition to the movable bottom plate for the manufacture of a block of the character shown by dotted lines in Fig. 17. Fig. 19 is a perspective view of a block having an offset to form the usual water-table. Fig. 20 is a detail perspective view of an auxiliary strip which may be employed in addition to the removable bottom plate for the purpose of molding a block of the character shown in Fig. 19. Fig. 21 is a detail perspective view of a slab which may be manufactured by a suitable adjustment of the mold-box. Fig. 22 is a detail perspective view of a form of core which it is preferred to employ in connection with the invention.

Similar numerals of reference are employed to indicate corresponding parts throughout the several figures of the drawings.

The main frame of the machine comprises opposite end standards 20 and an upper flanged bed-plate 21, the latter being provided with a longitudinally-disposed opening 22, extending for the entire length of the bed-plate between the inner faces of the standards to permit of the adjustment of the cores to any desired position in the length of the mold-box. The bed-plate is provided at each of its sides and ends with pairs of lugs 23, having slots for the passage of securing-bolts, by which they are secured to the bed-plate, the slots permitting adjustment of the lugs until the pivot-openings carried thereby are at any desired distance from the edges of the bed-plate in order to thereby vary the distance

between the sides of the mold-box and alter the width of the molded blocks. The outer ends of the lugs extend downwardly below the bed-plate for a considerable distance and are provided with openings 25 for the passage of hinge-pintles or pivots by which the side plates 26 and end plates 27 are connected to said pivot-blocks, the connection permitting the movement of the side and end plates from a vertical position to an approximately horizontal position to open the box and allow the removal of the block and the completion of the molding operation.

In the manufacture of blocks having curved external surfaces or ornamental faces having deep indentations there is always more or less danger of mutilation of the molded faces when the plates are swung to a horizontal position, and it becomes desirable to increase the radius of swinging movement in order that the separation of the design-plate from the block shall be in a line as nearly as possible at right angles to the surface of said block. To accomplish this, the adjustable pivot-lugs are extended downwardly for a considerable distance, thus permitting a separating movement of the design-plates without danger of mutilation of the molded block.

The end standards 20 are provided with vertical guiding-slots for the reception of a cross-bar 38 and the outwardly-projecting arms 39 of a core-carrying bar or plate 40, the cross-bar and arms 39 being rigidly secured together at points outside the slotted frames by rack-bars 41, adapted to intermesh with pinions 43, mounted on a shaft 44, adapted to suitable bearings. The frame also carries a shaft 45, provided at its opposite ends with pinions 46, adapted to intermesh with gears 47, secured to the shaft 44, and said shaft 45 is further provided with an operating-crank 47' (shown in Fig. 2) or a suitable belt or gear wheel, which may be used to impart a vertical reciprocating movement to the core-carrying bar or plate through the medium of the gears and rack-bars. The core bar or plate is of approximately the same length as the bed of the machine and comprises two side members spaced by an elongated slot 49, the adjacent faces of such members being provided with dovetailed guides 50, adapted to receive the lower ends of the adjustable and detachable core members. The cores, which may be of any contour, are carried by the core bar or plate and are adjustable longitudinally thereof, suitable securing devices, as set-screws 52, being employed to lock the cores in any position to which they may be adjusted, and said cores may be readily detached from the carrier when it becomes necessary to substitute cores of different size or shape or to wholly dispense with the cores when it becomes necessary to form a solid block. The core-carrying bar is provided at a point near one end with a laterally-extending arm 53, to which a core may be secured when the machine is employed for the manufacture of a corner-

4

731,323

substituted. Ordinarily it would be necessary to employ another set of removable bottom plates of a width equal to that of the block being made, and, as before stated, this materially increases the cost of the machine, as in practical use it is necessary to employ a very large number of bottom plates in order that opportunity may be had for molded blocks to set or dry. To overcome this difficulty, I employ removable and adjustable filling-strips of a character depending on the change in the contour of the block.

Fig. 11 illustrates the contour of a standard block; but in many cases it may be desirable to furnish a block having a thickened outer or inner wall in order to increase and strengthen the stability of the structure. When the thickness of only one wall of the block is to be increased, as to the extent indicated by dotted lines in Fig. 11, I employ a filling-strip 100 of the character shown in Fig. 12, said strip being in the form of an angle-bar having a vertical web, the inner wall of which is of a height equal to the thickness of the removable bottom plate, while portions of the lower web are continued inwardly to form lugs 101, which may have suitable sockets for the reception of the upper ends of the adjustable screws or supports 93, carried by the bed-plate. In using a strip of this character one of the side plates is adjusted outward to the desired distance by means of the adjustable pivot-lugs 23, and after suitable adjustment of the screws 93 the auxiliary strips 100 are placed in position, the sockets in the lugs 101 receiving the ends of said screws and serving to support the strips, or in some cases these strips may be allowed to rest directly on the bed-plate, the lower web of the strip being made of sufficient thickness for the purpose. The removable bottom plate of standard size is then placed in position in the usual manner and the concrete or similar material shoveled in and tamped, as previously described, the block being supported partly by the removable bottom plate and partly by the strip 100. After the completion of the molding operation the sides and ends of the mold-box are moved to the open position and the bottom plate removed with the molded block, leaving the auxiliary strip in place in the mold-box. A portion of the block will project beyond the edge of the bottom plate; but it is found in practice that the material will set sufficiently to allow this without any injury whatever to the block, and it is possible to manufacture the blocks on a practical scale with the use of removable bottom plates of four inches, or thereabout, less than the width of the block or, say, about two inches on each side of said block.

The strip 100 may be made at very small cost and may be said to take the place of separate sets of removable bottom plates, which would otherwise be necessary in the manufacture of a block of increased width,

so that the manufacturer is not compelled to carry in stock a large number of bottom plates of different size of which only one size can be used at a time.

In Fig. 13 is illustrated a block of standard size, the dotted lines showing a proposed increase in the width of both walls of the block, and in the manufacture of a block of the size indicated by these dotted lines I preferably employ a double filling-bar 102 of the character shown in Fig. 14, this double filling-bar being merely a duplication of the bar 100 and the two members being connected by cross-bars 103 in order to increase the stability of the structure. The side plates of the mold-box may be readily adjusted to accommodate the blocks of increased width, and after the molding operation is completed the narrow bottom plate of standard size may be employed to support the block.

In Fig. 15 is illustrated a form of block in which increased strength is provided for by decreasing the width of the core-openings, and when this is to be done I preferably employ a filling-bar of the character shown in Fig. 16 and comprising a double bar 104, having vertically-disposed ribs 105, which tend to support the inner portion of the molded block and act as auxiliaries to the removable bottom plate during the molding operation. This double bar is likewise provided with outwardly-projecting lugs 101 for engagement with the supporting-screws.

In some cases it may be desired to manufacture a block of the character shown in dotted lines in Fig. 17, in which case the width of the block is increased and at the same time the width of the core-openings is reduced, and this may be accomplished by combining the auxiliary bars or plates, (shown in Figs. 14 and 16,) the outer bars 101 being connected to the inner bars 105, as clearly shown in Fig. 18.

In the manufacture of blocks provided with water-tables, as at 109 in Fig. 19, I employ an auxiliary filling-bar 110, having an inclined surface to form the beveled upper edge of the block, and thereby mold the water-table usually found in the lower portions of buildings.

The method of manufacture is obvious and needs no detailed description.

For some work it is desirable to mold the material in the form of slabs of the character shown in Fig. 21, and to manufacture such slabs I employ removable division or spacing plates 120, which are placed in the mold-box, being disposed in vertical position and supported by the cores. The plates are merely held by contact with the cores and are not secured in position, so that when the material has been tamped and the slabs molded the withdrawal of the cores, as in the making of blocks, will release the division-plates and permit the ready removal of the same without danger of injury to the slabs, and said division-plates may be formed of cast metal,

731,323

5

either plain or ornamented, so as to form any desired design on the face of the slab. After the completion of the molding operation and the withdrawal of the cores the division-plates are removed, the sides of the mold-box are opened, and the removable bottom plate taken out with the slabs resting thereon.

Having thus described the invention, what is claimed is—

1. In a machine for molding hollow concrete blocks, the combination with the mold having movable sides and ends, of a core, a removable bottom plate, and a removable filling-strip for increasing the area of the block-support when the machine is adjusted for the manufacture of blocks of increased width.

2. In a machine for molding hollow concrete blocks, the combination with the mold having movable sides and ends, of a core, a removable bottom plate, and removable filling-strips serving to increase the effective area of said plate.

3. In a machine for molding hollow concrete blocks, the combination with the mold having movable sides and ends, of a core, a removable bottom plate, and a filling-strip having webs or ribs for filling the spaces between the sides of the core and the adjacent edge of the opening in the bottom plate.

4. In a machine for molding hollow concrete blocks, the combination with the mold-box and removable bottom plate, of an auxiliary filling-strip for increasing the effective area of the bottom plate, and means for adjustably supporting said strip in position in the mold-box.

5. In a machine for molding hollow concrete blocks, the combination with the mold-box

and removable bottom plate, of an auxiliary strip, and means for supporting the same in position within the mold-box to thereby form a water-table on the molded block.

6. In a machine for molding hollow concrete blocks, the combination with the mold having movable sides and ends, of a core, and removable division-plates arranged longitudinally of the mold and supported on one side by the core to thereby permit the molding of slabs.

7. In a machine for molding hollow concrete blocks, the combination with the mold having movable sides and ends, of a vertically-movable core, division-plates supported on one side by the core, and means for lowering the core to permit the removal of said plates.

8. In a device of the class specified, the combination with a bed-plate, of a plurality of adjustable lugs carried by the plate and having pivot-ears depending below the bottom of the plate, sides and ends connected to said pivot-ears, and a vertically-movable core disposed within the mold-box.

9. In a machine for molding hollow concrete blocks, the combination with a mold-box having movable side and end members, of a vertically-movable core-carrier, means for operating the same, a core comprising a plurality of detachable nested sections, and a removable bottom plate having an opening for the passage of said core.

In testimony that I claim the foregoing as my own I have hereto affixed my signature in the presence of two witnesses.

HARMON S. PALMER.

Witnesses:

J. ROSS COLHOUN,
C. E. DOYLE.

Patent 11: H. S. Palmer, *Machine for Molding Hollow Concrete Building Blocks*, U. S. Patent No. 731,323, June 16, 1903.

D25-151

EX

D9075

XR

D 36,772

DESIGN.

No. 36,772.

PATENTED FEB. 2, 1904.

H. S. PALMER.
ARTIFICIAL BUILDING BLOCK.
APPLICATION FILED DEC. 21, 1903.

Fig. 1.



Fig. 2.



WITNESSES:

Just H. Blackwood
Warren G. Ogden

INVENTOR

Harmon S. Palmer

BY *W. H. ...*

Attorney.

Patent 12: H. S. Palmer, *Artificial Building Block*, U. S. Patent No. 36, 772, Feb. 3, 1904.

No. 36,772.

Patented February 2, 1904.

UNITED STATES PATENT OFFICE.

HARMON S. PALMER, OF WASHINGTON, DISTRICT OF COLUMBIA.

DESIGN FOR AN ARTIFICIAL BUILDING-BLOCK.

SPECIFICATION forming part of Design No. 36,772, dated February 2, 1904.

Application filed December 21, 1903. Serial No. 186,130. Term of patent 7 years.

To all whom it may concern:

Be it known that I, HARMON S. PALMER, a citizen of the United States, residing at No. 1450 Binney street northwest, in the city of Washington, District of Columbia, have invented a new, original, and ornamental Design for Artificial Building-Blocks, as disclosed by the accompanying drawings, made a part of this specification, of which the following is a description.

Figure 1 is a front view of the block, and Fig. 2 is a side view.

Having thus disclosed my invention, what I claim, and desire to secure by Letters Patent, is—

The ornamental design for an artificial building-block substantially as herein shown.

In testimony whereof I affix my signature in presence of two witnesses.

HARMON S. PALMER.

Witnesses:

JOS. H. BLACKWOOD,
WARREN G. OGDEN.

Patent 12: H. S. Palmer, *Artificial Building Block*, U. S. Patent No. 36, 772, Feb. 3, 1904.

No. 800,674.

BEST AVAILABLE COPY

PATENTED OCT. 3, 1905.

H. S. PALMER.
HOLLOW BUILDING BLOCK.
APPLICATION FILED MAR. 24, 1904.

Fig. 1.

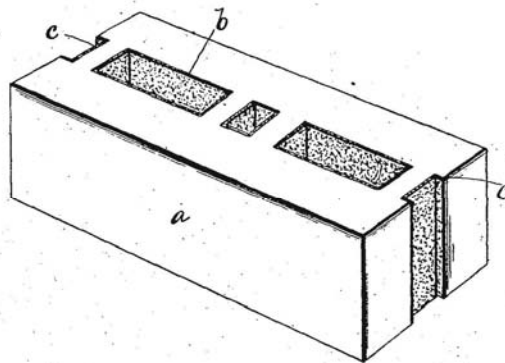
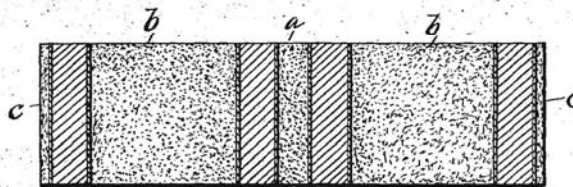

Fig. 2.



Witnesses
Just Blackwood
H. P. Doolittle

Inventor
Harmen S. Palmer
By W. A. Doolittle
Attorney

Patent 13: H. S. Palmer, *Hollow Building Block*, U. S. Patent No. 800, 674, Oct. 3, 1905.

BEST AVAILABLE COPY

UNITED STATES PATENT OFFICE.

HARMON S. PALMER, OF WASHINGTON, DISTRICT OF COLUMBIA.

HOLLOW BUILDING-BLOCK.

No. 800,674.

Specification of Letters Patent.

Patented Oct. 3, 1905.

Application filed March 24, 1904. Serial No. 199,818.

To all whom it may concern:

Be it known that I, HARMON S. PALMER, a citizen of the United States, residing at Washington, in the District of Columbia, have invented new and useful Improvements in Hollow Building-Blocks, of which the following is a specification.

My invention relates to improvements in hollow building-blocks; and its object is to provide a block of increased durability.

The invention is illustrated in the accompanying drawings, in which—

Figure 1 is a perspective view of a hollow building-block constructed in accordance with my improvements, and Fig. 2 is a central and vertical section of the same block.

Referring to the drawings, *a* is the block proper, *b* represents holes formed therein, and *c* represents recesses formed in the ends of the block. On the surfaces of the block within these holes and recesses is formed by molding the same with the block or by applying to the surfaces of the block in any suitable way a moisture-proof lining of asphalt, coal-tar, or other suitable moisture-proof material. By this construction the block is rendered impermeable to moisture through

the spaces forming the central holes and recesses of the block.

Having thus described my invention, what I claim is—

1. An artificial hollow building-block having a central hole adapted to register with a hole of a corresponding similar block and having a coating of plastic moisture-proof material on the walls of said hole whereby a protective lining is afforded for the block and the inner air-space extending through the blocks maintained in a dry state, substantially as described.

2. A building-block provided with a central hole and with recesses adapted to register with similar recesses in an adjoining block and a coating of a plastic moisture-proof material on the walls of said hole and recesses, substantially as and for the purpose described.

In testimony whereof I have signed my name to this specification in the presence of two subscribing witnesses.

HARMON S. PALMER.

Witnesses:
JOS. H. BLACKWOOD,
H. P. DOOLITTLE.

Patent 13: H. S. Palmer, *Hollow Building Block*, U. S. Patent No. 800, 674, Oct. 3, 1905.

No. 793,591.

PATENTED JUNE 27, 1905.

F. E. KIDDER.
BUILDING BLOCK AND WALL.
APPLICATION FILED JUNE 23, 1903.

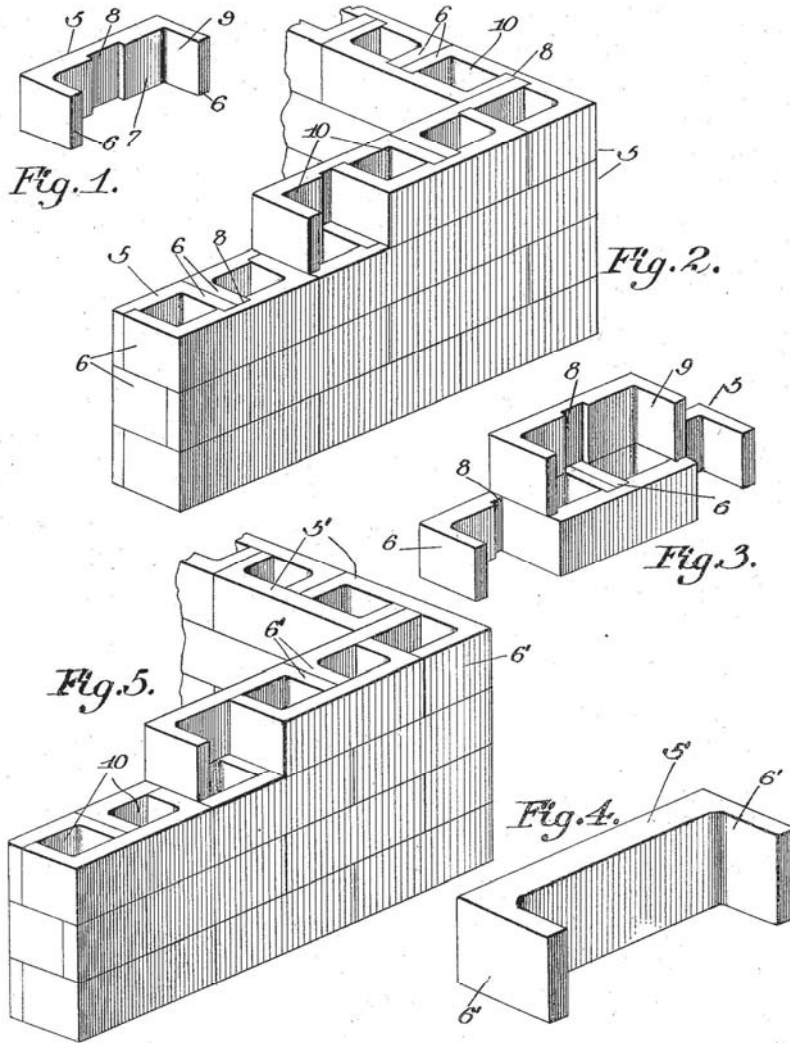

Witnesses
E. J. Stewart
L. M. Vickers

Frank E. Kidder, Inventor.
by *C. A. Snow & Co.*
Attorneys

PHOTO LITHOGRAPHED BY SWEET & WILHELMUS LITH. & PR. CO. NEW YORK.

Patent 14: F. E. Kidder, *Building Block and Wall*, U. S. Patent No. 793,591, June 27, 1905.

No. 793,591.

Patented June 27, 1905.

UNITED STATES PATENT OFFICE.

FRANK E. KIDDER, OF DENVER, COLORADO, ASSIGNOR TO JOHN A. FERGUSON, OF DENVER, COLORADO.

BUILDING-BLOCK AND WALL.

SPECIFICATION forming part of Letters Patent No. 793,591, dated June 27, 1905.

Application filed June 23, 1903. Serial No. 162,805.

To all whom it may concern:

Be it known that I, FRANK E. KIDDER, a citizen of the United States of America, residing in the city and county of Denver and State of Colorado, have invented certain new and useful Improvements in Building-Blocks and Walls; and I do declare the following to be a full, clear, and exact description of the invention, such as will enable others skilled in the art to which it appertains to make and use the same, reference being had to the accompanying drawings, and to the figures of reference marked thereon, which form a part of this specification.

15 This invention relates to improvements to artificial-stone building-blocks and walls constructed from the same.

The object of the invention is to provide a strong, durable, and inexpensive block having the appearance of cut or sawed stone and which when laid side by side in superposed courses will form a strong substantial wall having vertically-disposed flues or air-spaces of substantially uniform width.

25 The invention consists in the construction and novel combination and arrangement of parts hereinafter fully described, illustrated in the accompanying drawings, and pointed out in the claims hereto appended, it being understood that various changes in form, proportion, and minor details of construction may be resorted to without departing from the principle or sacrificing any of the advantages of the invention.

35 In the accompanying drawings, forming a part of this specification, Figure 1 is a perspective view of a building-block constructed in accordance with my invention. Fig. 2 is a perspective view of a fragmentary portion of a wall built of the blocks shown in Fig. 1. Fig. 3 is a similar view showing a portion of the completed wall. Fig. 4 is a perspective view of another form of block, and Fig. 5 is a similar view of a portion of a wall built from the blocks shown in Fig. 4.

45 Similar numerals of reference indicate corresponding parts in all the figures of the drawings.

The building-blocks may be molded or oth-

erwise formed from concrete, terra-cotta, or 50 other suitable material, and each consists of an elongated body portion 5, provided with terminal projections 6, extending laterally from the inner vertical face 7 of the block, as shown. The projections 6 are preferably of equal 55 thickness and of a height equal to the height of the block, so as to form a continuous bearing-face at the top and bottom of the block, and thereby prevent any tendency of the blocks to wobble when placed one upon the other. 60

The inner vertical face of the block 5 is provided with an intermediate transversely-disposed groove or recess 8, the sides of which are arranged parallel to the inner walls 9 of the projections 6, as shown. The groove or 65 recess 8 is preferably of a width equal to the combined width of the projections 6, said recess being adapted when the block is laid into a wall to receive the adjacent projections of the abutting blocks on the opposite side of 70 the wall.

In constructing a wall from the blocks shown in Fig. 1 said blocks are preferably laid side by side and arranged in superposed courses, with the terminal projections 6 of one block 75 disposed within the groove or recess 8 of the opposite block, so that the blocks of the several courses will break joint and form a plurality of vertically-disposed flues or air-spaces 10 of substantially uniform width. The wall is preferably constructed two blocks thick, 80 with the terminal projections turned inwardly, so as to present a smooth exterior finish on each side of said wall. The thickness of the wall, however, may be regulated as desired 85 by making the projections shorter or longer. Attention is called to the fact that in building the wall the blocks are laid edge downward, with the terminal projections of adjacent blocks on one side of the wall in engage- 90 ment with the side walls of the groove or recess of the block on the opposite side of the wall, thereby effectually preventing independent longitudinal and transverse displacement of the blocks comprising the several courses. 95 By arranging the blocks in this manner a strong, durable, and well-bonded wall is obtained which will effectually withstand all lat-

Patent 14: F. E. Kidder, *Building Block and Wall*, U. S. Patent No. 793,591, June 27, 1905.

2

793,591

eral as well as longitudinal strains to which it may be subjected.

In Figs. 4 and 5 the body portion 5' of the block is provided with terminal lateral projections 6', similar to those shown in Fig. 1, while the space on the inner face of the block between said projections is entirely free from protuberances or other obstructions. The blocks shown in Fig. 4 are also preferably laid in superposed courses, with the projections of adjacent blocks on one side of the wall facing or engaging the intermediate portions of the unobstructed vertical face of the block on the opposite side of the wall, as clearly shown in Fig. 5.

Having thus described the invention, what is claimed is—

1. A building-block comprising a body portion provided with terminal projections, the inner walls of which are unobstructed and extend laterally at right angles to the inner unobstructed vertical face of the block, there being a transverse groove or recess formed in the inner vertical face of the block intermediate said projections, the sides of the groove being disposed parallel with the inner walls of the lateral projections.

2. A building-block comprising a body por-

tion provided with terminal projections of the same height as the block and having their inner walls extended laterally at right angles to the inner vertical face of said block, there being a transverse groove or recess formed in the central portion of the inner vertical face of the block of a width equal to the combined width of the lateral projections, the sides of the groove being disposed parallel with the straight inner walls of said projections.

3. A building-block comprising a body portion provided with terminal projections, the inner walls of which extend laterally at right angles to the inner vertical face of the block, said projections being of the same length and of a height equal to that of the block, there being a transverse groove or recess formed in the central portion of the inner vertical face of the block of a width equal to the combined width of the lateral projections, the sides of said grooves being disposed parallel with the inner walls of said projections.

In testimony whereof I affix my signature in presence of two witnesses.

FRANK E. KIDDER.

Witnesses:

DENA NELSON,
A. J. O'BRIEN.

No. 828,767.

PATENTED AUG. 14, 1906.

H. S. PALMER.

MACHINE FOR MAKING CONCRETE BLOCKS.

APPLICATION FILED AUG. 14, 1905.

6 SHEETS—SHEET 1.

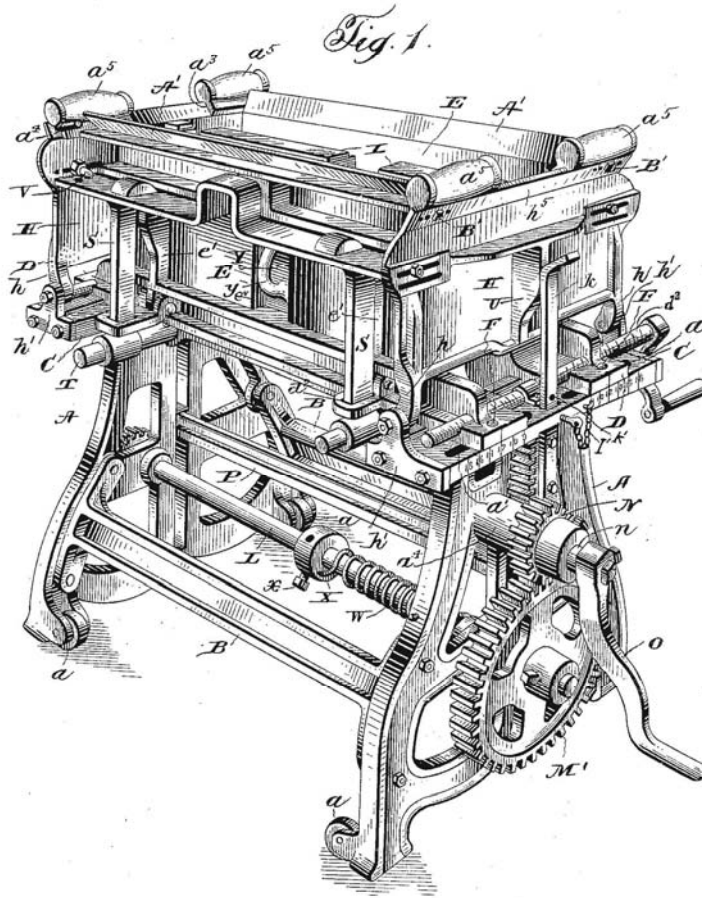

Witnesses:

James Hutchinson
Norris W. Owens

Inventor:

Hannon S. Palmer
by *Prindle & Williamson*
Attorneys.

THE NORRIS PEYERS CO., WASHINGTON, D. C.

Patent 15: H. S. Palmer, *Machine for Making concrete Blocks*,
U. S. Patent No. 828,767, Aug. 14, 1906.

No. 828,767.

PATENTED AUG. 14, 1906.

H. S. PALMER.
 MACHINE FOR MAKING CONCRETE BLOCKS.
 APPLICATION FILED AUG. 14, 1905.

6 SHEETS--SHEET 2.

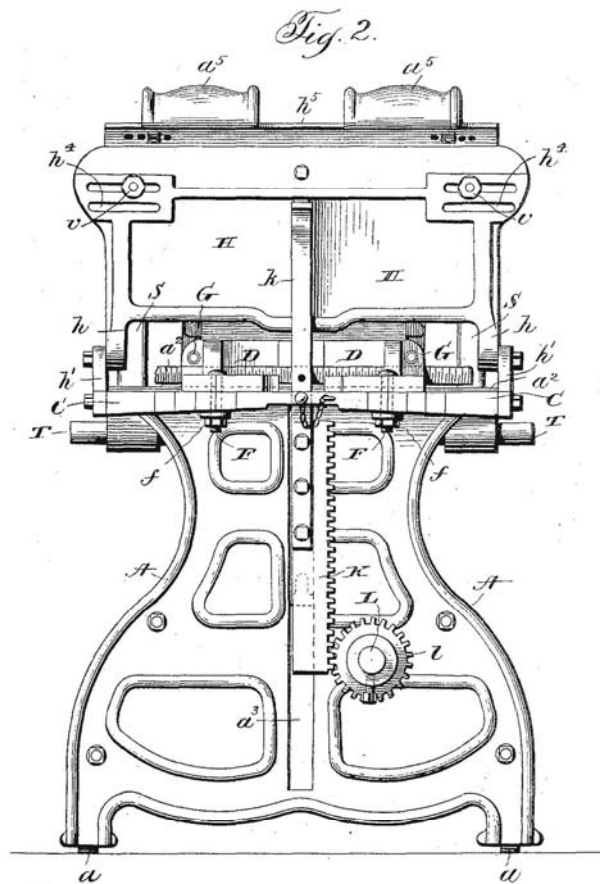

Witnesses
Jas. Hutchinson.
Horris W. Cluett

Inventor
Harmon S. Palmer,
 by *Prindle & Williamson*
 Attorneys

THE NORRIS PETERS CO., WASHINGTON, D. C.

Patent 15: H. S. Palmer, *Machine for Making concrete Blocks*,
 U. S. Patent No. 828,767, Aug. 14, 1906.

No. 828,767.

PATENTED AUG. 14, 1906.

H. S. PALMER.
MACHINE FOR MAKING CONCRETE BLOCKS.

APPLICATION FILED AUG. 14, 1906.

6 SHEETS—SHEET 3.

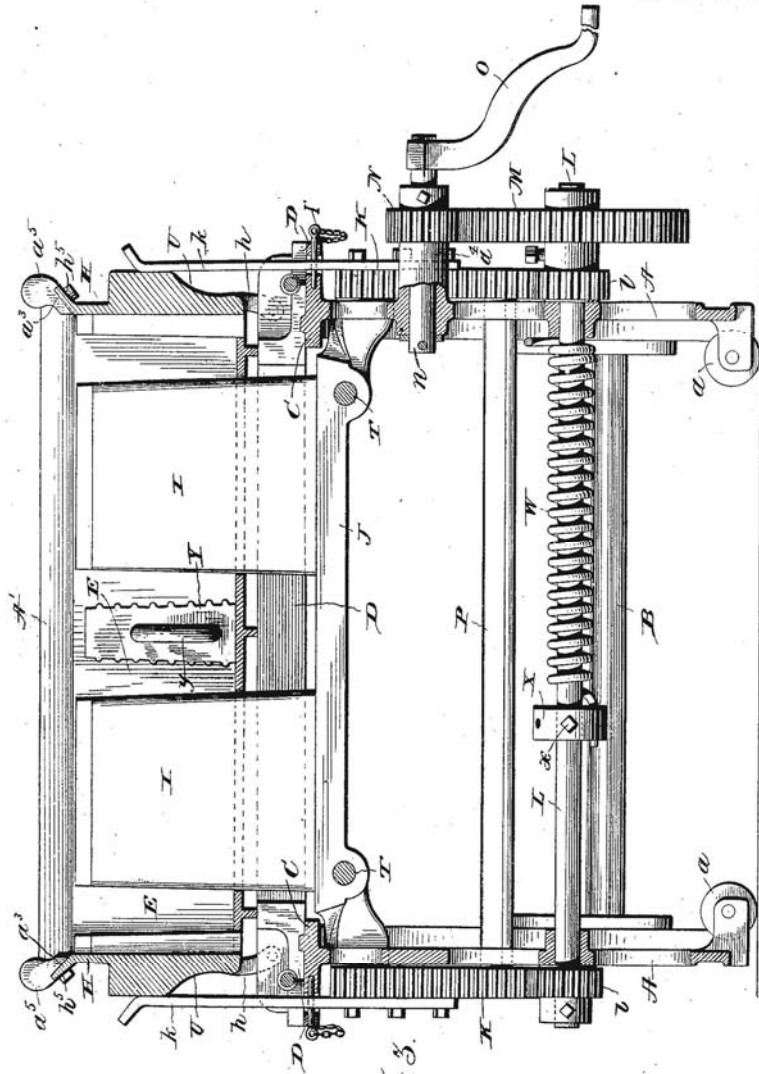

Witnesses
James Hutchinson
Thomas W. Lewis

Fig. 3.

Inventor
Harmon S. Palmer,
 by *Prindle & Williams,*
 Attorneys

THE MORRIS PETERS CO., WASHINGTON, D. C.

Patent 15: H. S. Palmer, *Machine for Making concrete Blocks*, U. S. Patent No. 828,767, Aug. 14, 1906.

No. 828,767.

PATENTED AUG. 14, 1906.

H. S. PALMER.
 MACHINE FOR MAKING CONCRETE BLOCKS.
 APPLICATION FILED AUG. 14, 1906.

6 SHEETS—SHEET 4.

Fig. 4.

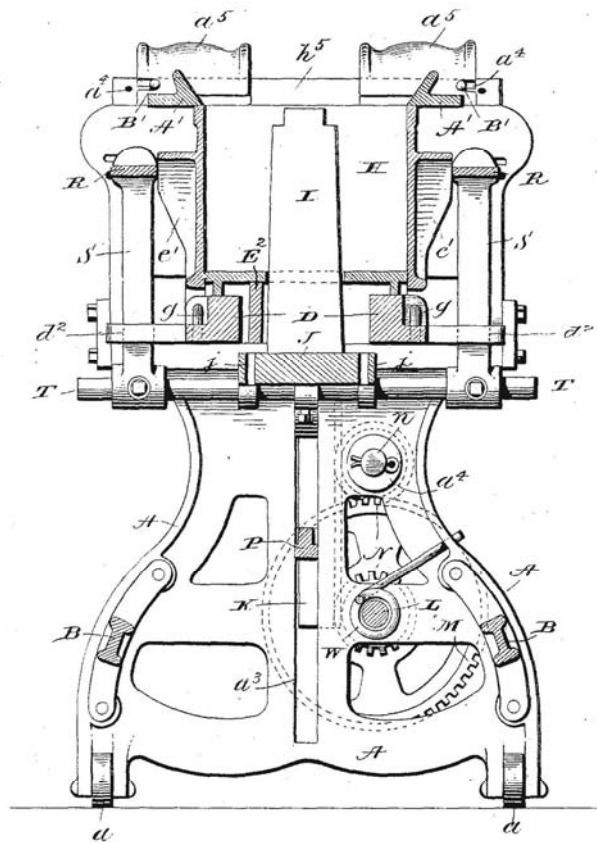

Witnesses
Jas. Hutchinson
Norris W. Owens

Inventor
Harmon S. Palmer
 by *Pinckney M. Williams*
 Attorneys

THE NORRIS PETERS CO., WASHINGTON, D. C.

Patent 15: H. S. Palmer, *Machine for Making concrete Blocks*, U. S. Patent No. 828,767, Aug. 14, 1906.

No. 731,323.

PATENTED JUNE 16, 1903.

H. S. PALMER.
MACHINE FOR MOLDING HOLLOW CONCRETE BUILDING BLOCKS.

APPLICATION FILED APR. 9, 1903.

NO MODEL.

7 SHEETS—SHEET 5.

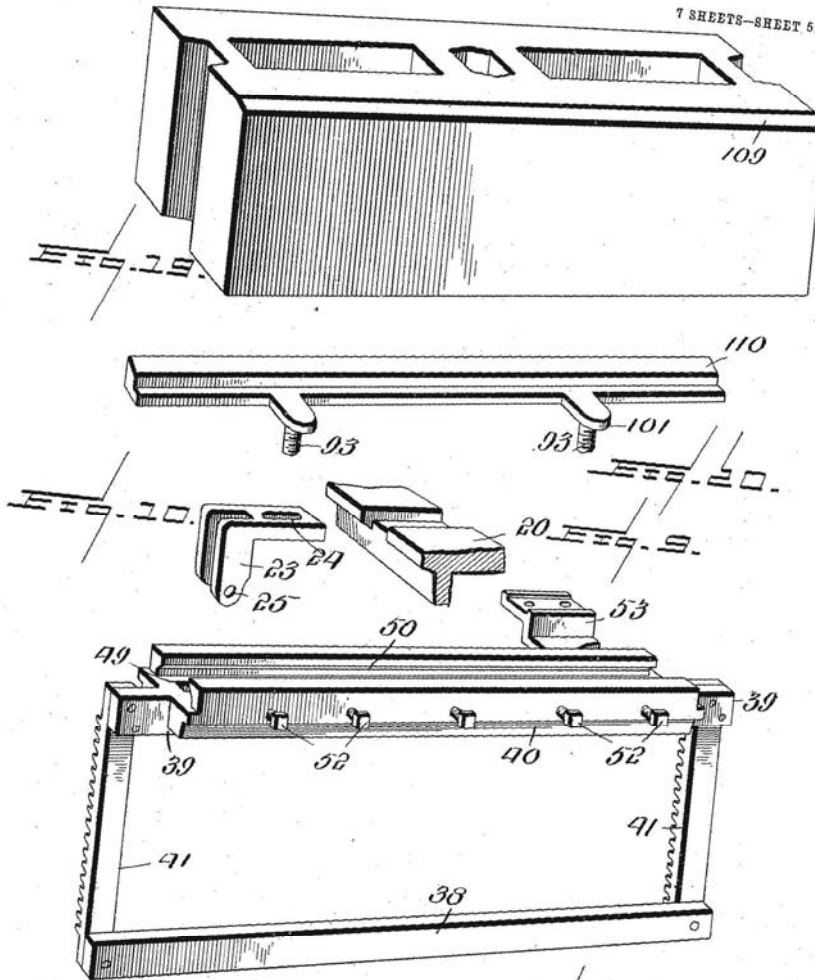

Witness
F. Doyle
Attest
H. S. Palmer

FIG. 8.
H. S. Palmer, Inventor.
by C. A. Knowlton
Attorneys

THE MORRIS PETERS CO., PHOTOLITHO., WASHINGTON, D. C.

Patent 15: H. S. Palmer, Machine for Making concrete Blocks, U. S. Patent No. 828,767, Aug. 14, 1906.

No. 828,767.

PATENTED AUG. 14, 1906.

H. S. PALMER.
MACHINE FOR MAKING CONCRETE BLOCKS.
APPLICATION FILED AUG. 14, 1905.

8 SHEETS—SHEET 6.

Fig. 10.

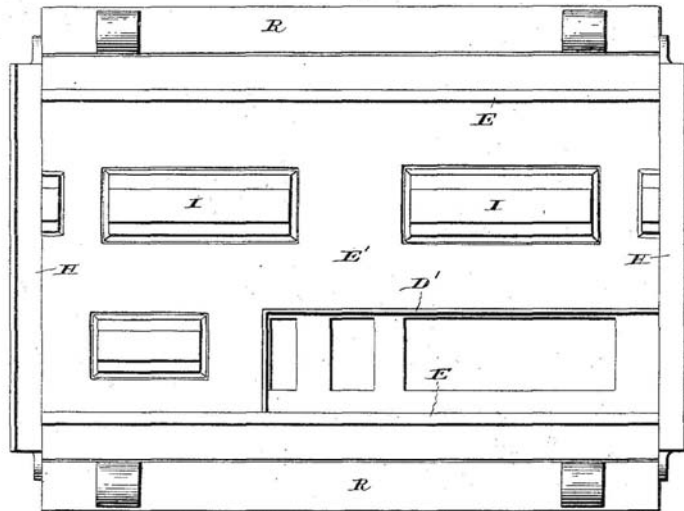

Fig. 12.

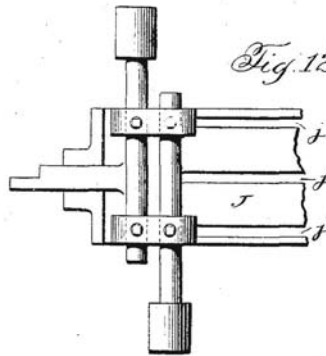

Fig. 13.

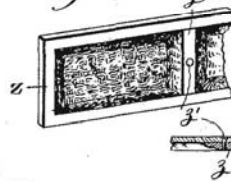
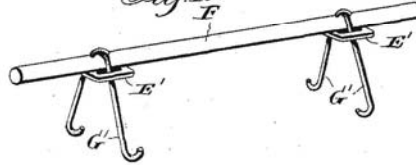

Fig. 14.



Fig. 15.



Witnesses
Jas. S. Hutchinson
Norris W. Lewis

Inventor
Harmon S. Palmer,
 by *Prindle and Williamson*
 Attorneys

THE NORRIS PETERS CO., WASHINGTON, D. C.

Patent 15: H. S. Palmer, *Machine for Making concrete Blocks*, U. S. Patent No. 828,767, Aug. 14, 1906.

2

828,767

restrain the side plates from outward movement. As each side plate is carried by but a single bar or part, it will be evident that the operation of adjusting the side plate may most easily and quickly be performed. To preserve the position of the plate-carrying bar in being shifted from one point to another, a guide-rib a^2 is preferably provided on the top of each leg table or flange, which engages a groove in the under side of the bar, and to simplify and to render the accurate adjustment of the side plates easy a gage or scale is provided on the outer edge of the table or flange of each leg with graduations spaced apart the distances required for the different width of blocks to be made, and on one of the tables or flanges the graduations are numbered with numbers corresponding to the transverse dimensions of the blocks to be made. On the contiguous end of each of the side-plate-carrying bars a line or pointer is provided for coöperation with the index or scale. It will be seen that by the employment of these scales the adjustment of the sides of the mold may be most easily and yet accurately accomplished, and as a scale or index is provided at each end of the machine perfect parallelism of the side plates is assured.

If preferred, the shifting of the hinge-bars D may be done by power by providing a transversely-extending shaft d^3 , having right and left threads to engage the correspondingly-threaded openings in the respective bars, on one end of which shaft a crank or hand-wheel is mounted, by which it may be revolved, the shaft of course being swiveled in suitable bearings to prevent it moving longitudinally and to compel the movement of the hinge-bars when it is revolved.

The side plates E are detachably pivoted to their supporting-bars, so that side plates of one configuration can be substituted for side plates of another configuration, the pivoting means consisting of two hinge-lugs e at the bottom of each side plate near the ends thereof and a pair of lugs d for each hinge-lug e , the latter being placed between the pair, and a pivot-pin G, passing through the set of lugs e and d and having at one end a radial extension or arm g , adapted to be moved into and out of a notch d' in the bar D, said extension or arm when by the turning of the pin it is disengaged from the notch leaving the pin free to be withdrawn from the lug and when it is seated in the notch preventing the withdrawal of the pin. Not only is this hinge construction a simple and entirely efficient one, but it is valuable because it so greatly facilitates the removal and replacement of a side plate.

In addition to the two side plates E the mold-box has two end plates H, between which the two side plates are situated, and each of said end plates has near each end and

at its bottom a hinge-lug h , pivoted to a bracket h' on the contiguous leg table or flange, and the length of each end plate is such, together with its position with reference to the ends of the two side plates, that the one pair of end plates serves for all the blocks that may be made within the capacity of the machine irrespective of the width of such blocks, which of course is a feature of great practical value, since if extra end plates were required for each width of block to be made it would add greatly to the cost of the machine and render its use inconvenient.

The side and end plates of the mold-box are automatically opened and closed, and the means by which this is accomplished is fully described hereinafter.

For the support of the cores I, which may be any number desired, a core-carrier J is employed that consists of a bar that extends lengthwise of the machine and at its end passes through vertical slots a^3 in the respective legs A. On the outer side of each leg A said core-carrier is provided with a vertical rack K, with which meshes a pinion l upon a longitudinal shaft L, turning in bearings in the legs A and having fixed to it on the outside of one of the legs a gear-wheel M, which meshes with a pinion N. The pinion N is mounted on a short or gudgeon shaft n , journaled in an extended hub or boss a^4 on the contiguous leg A, and on the outer end of said shaft is mounted a removable crank O, by which the shaft and the pin may be revolved, and thus power transmitted to the shaft L to actuate the core-carrier and racks. The racks near their lower ends are connected by a stiffening or brace bar P. The core-carrier is shown as provided with several series of holes j for the attachment of cores or other machine members thereto and in different positions or relations, according to the nature of the work to be done. Thus when a single hollow block is to be made only cores are attached to the core-carrier. Should, for example, it be desired to make several separate blocks at the same time, then by means of the holes at the transverse center of the core-carrier one or more plates Q, (shown in Fig. 9,) having a length equal to the length of the desired blocks, may be bolted to the core-carrier to separate the mold-box into longitudinally-extending compartments, and cores for forming the chambers or openings in each of the narrow blocks, which may thus be made, are attached to the core-carrier by the holes at either side of the center thereof. Should it be desired to form a considerable number of small solid blocks or bricks at one time, this can be done by bolting to the core-carrier in lieu of the cores a plate having a number of thin vertical walls or partitions separated by spaces corresponding to the thickness of the bricks, a bottom plate or follower, such as is hereinafter more fully re-

Patent 15: H. S. Palmer, *Machine for Making concrete Blocks*, U. S. Patent No. 828,767, Aug. 14, 1906.

828,767

3

ferred to, being used to support the bricks, that is provided with slots for the respective partitions.

The upper surface of the core-carrier adjacent each leg A is inclined downwardly and inwardly, the downward inclination being from the transverse center of the core-carrier in each direction, so that should any concrete or block material drop upon these portions of the core-carrier they will at once slide therefrom and away from the gearing, so that all liability of the latter being choked or clogged by the concrete or block material is obviated.

I utilize the core-carrier for automatically operating the mold-box sides and ends, so that when the core-carrier is raised to lift the cores or other parts carried thereby into position in the mold-box the sides and ends may be raised into closed position, and when the core-carrier descends its descent will at the same time be attended by the lowering or opening outward of the mold-box sides and ends. For raising the two side plates or swinging them upward on their hinges to a closed position one or more, preferably two, ribs e' are provided on the outer side of each plate, whose outer edges have an inclined or cam-like formation, with which ribs a longitudinally-extending bar R, that is connected with the core-carrier, so that it is raised and lowered therewith, engage when said bar R ascends. The bar R is bolted near its ends to two posts or uprights S, which at their lower ends are attached, respectively, to horizontal rods T, secured to the core-carrier. The rods T are preferably made of shafting, because thereby a cheapening of the cost of manufacture of the machine is secured. This is so because such shafting is stock material, and for attaching the rods to the core-carrier it is necessary merely to bore or drill holes through the core-carrier, an operation that can easily and inexpensively be done on an ordinary drill, to the face-plate of which the core-carrier may be readily bolted, the holes for the rod, since the latter consist of standard shafting, being of standard size. The connection between the bars R and the core-carrier must of course be adjustable to enable the positions of the bars R to be changed, according to the width of the block to be made, and where, as shown in Figs. 1 to 5 of the drawings, a single rod T is employed at each end of the core-carrier and passed through the latter to opposite sides thereof such adjustment is provided for by slidably mounting the posts or uprights upon the rods and securing them in the desired adjusted position by set-screws. To avoid separate manipulation of the posts or uprights in changing the adjustment of the machine, I pass each through a hole or slot d' in the side-plate-supporting bars D, so that when the latter is shifted it will move with it the posts

or uprights thus attached to it. In some instances it may be desirable to avoid the undue protrusion of the ends of the rods T at the sides of the machine, and to obviate this instead of employing a single rod at each end of the core-carrier for two posts on opposite sides thereof a separate rod for each post may, as shown in Fig. 12, be employed and the two rods placed alongside of each other, each in its own bearings on the core-carrier and each being adjustable independently of the other to adjust the position of the side-plate-operating bars R, the adjustment in this case being effected by moving the rods and not by moving the posts or uprights thereon, the latter being fixed to the rods.

For lifting the end plates H there is fastened to the core-carrier or to each rack-bar K a vertical rod k , whose upper end is adapted to engage and coact with a cam-rib U on the end plate similar to the cam-ribs on the side plates. The opening of the mold-box by the swinging downward of the side and end plates is effected by gravity and takes place as the closing-bars descend. For the purpose of insuring the downward swinging of the side and end plates when they are free to swing downward by the descent of their lifting devices the center of gravity of each of these plates is placed at a point well outside of a plane passing vertically through their pivots, and this in part is produced by the presence of the cam-ribs on the outer sides of the plates and by other longitudinally-strengthening ribs on the outer side of the plates near the tops thereof. To firmly lock the side and end plates of the mold-box in their closed position, so that they will be able to withstand the strains in forming the block, I provide in each end of each side-plate-lifting bar R a hole, and vertically in line therewith when the end plates are closed there is a vertical pin or projection V on each end plate, which as the lifting-bar rises enters the contiguous hole, and thus both the end plates and the side plates are restrained most firmly against any tendency to move outward or open. The pin or projection V has at its upper end a right-angle shank which is threaded and passes through a hole in the end plate, and there is a nut v on said shank on each side of the end plate, by which the pin or projection is securely fastened in place. The pin or projection is thus adjustable to compensate for wear, and the hole in the end plate in which it is placed is in the form of a horizontal slot, so that it may be adjusted laterally to suit the adjustment of the mold-box for different blocks. To supplement the action of the nuts in holding the pins or studs from lateral movement outwardly, the side surfaces (preferably the outer side surfaces) of the end plate with which the nut on the outer side of said plate engages is inclined outwardly and laterally in a direction away

Patent 15: H. S. Palmer, *Machine for Making concrete Blocks*, U. S. Patent No. 828,767, Aug. 14, 1906.

828,767

from the end plate, so that a wedging or crowding of the nut thereagainst is produced by any tendency of the pin outward. The pins or projections also serve as stops to arrest the ascent of the cores at the proper level, and I avail myself of this function for the manufacture of blocks having passages to extend only partially through them, and to do this I provide a second slot k^2 in the end plates nearer the plate-axis, in which the pin or projection V may be placed, and when it is so placed the cores will not rise to a height which would place their tops level with the top of the mold-box, and therefore the concrete or block material placed in the mold-box will overlie the tops of the cores.

It will be understood that the cam-ribs on the mold-box plates have such form that there may be a continued ascent of the lifting-bars R after the mold-box plates have been moved to proper position to close the mold to enable the engagement of the holes of said bars and the pins or projections T without any disturbance of the position of the mold-walls. This form of the cam-ribs is also important, because when the mold is to be opened the cores will be lowered a short distance to free them from the newly-formed block before the side and end walls begin to open, so that injury to the newly-formed block by cracking it be avoided, which might be caused by first taking away its support by the mold-walls.

The lifting of the cores and the upward swinging of the mold-walls to close the machine may be done by a manual operation; but preferably I construct the machine so that the closing thereof is done automatically. I do this by providing the machine with a spring which acts upon gearing to lift the core-carrier. This spring may be applied in any desired way; but a very good way to employ it is to give it the form of a coil or helical spring W, encircling the shaft L, one end of the spring being attached to some stationary part of the machine and the other to a collar X on said shaft. The collar X is rotatable upon the shaft to enable the tension of the spring to be adjusted as may be found necessary, the collar being provided with a number of holes in its periphery adapted to receive a bar or lever by which it may be easily turned. A set-screw x is provided for securing the collar when the spring has been placed under the desired tension. The mold sides when the mold is fully open lie substantially horizontal, and when in this position the point of engagement therewith by the bars R and k is so close to the axis of said sides that the weight of the sides is sufficient to hold them against the lifting tendency of the spring W, and this enables the newly-formed block, resting upon a removable bottom plate of usual construction, to be removed without the provision of any special holding means to keep the mold-walls and the cores in their lowered position. A slight movement of the operating-crank is all that is necessary to release the locking of the spring, as I have just described, and thereupon the spring will act to automatically close the mold-box. The spring W is also of use, and an important one, in that as it offers resistance to the opening of the mold-box it prevents such sudden and violent opening thereof as might result in the cracking and injury of the newly-formed block.

It is desirable sometimes to make several blocks at the same time which are shorter than the length of the mold and to give to their inner ends in the mold a configuration that is not possible where a vertically-movable transverse division-plate or core is employed. I adapt my machine for this work by providing it with a removable core or division-plate that may be inserted into the mold-box and withdrawn therefrom by a horizontal movement, one of the mold side plates being provided with a slot or opening e' , through which said horizontally-movable core or division-plate Y may be passed, said core or division-plate being provided upon its outer end with a handle y , by which it may be manipulated. It will be seen that after the mold-box is closed the horizontally-removable core Y may be placed therein, and after the molding of the blocks it is withdrawn before the cores and mold-walls are operated to open them. By reason of its horizontal movement the ends of the blocks which are formed by its sides may be given a configuration—such, for example, as a horizontally-ribbed one—which would be impossible by the employment of a vertically-movable core or partition-plate. The advantage of withdrawing the core Y before opening the mold is that the same core may be immediately used in the manufacture of other blocks, whereas if the core were left in position until after the mold-box is opened it would have to remain with the newly-formed blocks until they had set sufficiently to enable the core to be removed, and this of course would necessitate the employment of a great number of such cores. The web or neck of stone that unites two blocks thus made can easily be cut or removed. When several short blocks are thus made in one mold, it may be desirable to provide for each block its own removable bottom plate. Instead of the longitudinally-removable core being used to make two short blocks the construction illustrated in Fig. 11 may be used, where a thin core or projection i is attached to the core-carrier, and on the inner side of each side plate there is a rib e , which reaches to said core or projection to complete the separation of the mold.

As a matter of precaution a lock is preferably provided to prevent the accidental descent of the cores and the opening of the

Patent 15: H. S. Palmer, *Machine for Making concrete Blocks*, U. S. Patent No. 828,767, Aug. 14, 1906.

828,767

5

mold-box, which, as shown, may consist of a pin I' , adapted to pass through a hole in one of the legs A and either one of two holes k' in one of the end-wall-lifting rods k , holes being provided because of the employment of the machine for making blocks with holes or passages all the way through them from top to bottom and blocks with such holes or passages extending only partially through them.

In producing blocks with what is known as the "rock-face" finish it is desired sometimes to have narrow fillets or smooth portions at intervals dividing the rock-finish surface into sections of rock-finish, and to enable my machine to be used for making blocks having a side with a uniform rock-finish from end to end, as well as one interrupted by the use of fillets, I detachably secure to the inner side of the side plates of the machine which are formed to produce a rock-finish extending from end to end of the block pieces or sections Z , having raised narrow smooth portions z for producing the smooth fillet-strips on the face of the block, these pieces or blocks Z having adjacent the smooth raised portion portions that have a rough or rock face configuration that merge into the adjacent similar configuration of the side plates and having their portions that abut against the latter conforming thereto. Screws or bolts z' are provided as a convenient means for the detachable connection of the pieces or blocks Z to the side plates.

Each of the end plates of the mold is provided with an upwardly and outwardly inclining flange h^2 at its upper edge, which constitutes a hopper-like extension or guide for the block material being placed in the mold-box, and for each of the side plates of the mold-box there is provided a longitudinally-extending bar A' , having an inclined surface, which when the bar is placed in proper position above or over the upper edge of its side plate when the latter is in its vertical position inclines upward and outward and constitutes a guide or hopper-like portion for said side plate. At each end said bar A' has a transverse groove a^3 to fit over the flange of the end plate of the mold-box, and it is provided also at each end with an open-ended slot a^4 for engagement by a pin or stud B' , attached to the end-plate flange in a position to gage or fix the position of the hopper-bar properly with reference to its side plate. Said pin or stud is preferably in the form of a screw or bolt, and of course it is adjustable to different positions, according to the adjustment of the mold-box, for making blocks of one width or another, a series of holes being provided in said flange for this purpose. Said screws or bolts are used, as shown in Fig. 16, when the machine is to be shipped or transported to clamp or fasten the hopper-bars to the end plates. At each end the hopper-bars are provided with handles a^5 , by which they

may be placed in and removed from position and by which one or the other may be slid across the top of the mold-box, being guided by the end-plate flanges h^2 after the block material has been placed and tamped in the mold-box, so that the hopper-bar thus serves as a striker-off or trowel to remove the surplus material and level off or smooth the top of the newly-formed block. Instead of using the bars A' for the hopper the construction which is shown in Fig. 17 may be used, which consists of a bar A^2 , having an inclined material-guiding surface and which is pivoted to the outer edge of a horizontal flange on the side plate, so that it may be swung or turned on its pivots from a position in use to a position out of use, leaving the top of the mold-box free from obstruction, so that the block material may be leveled off or smoothed.

My machine is adapted for making what are known as "corner-blocks," which are blocks having an angle or L-shape form, and when such blocks are to be made the hinge-bars of the side plates are adjusted a distance apart equal to the width of the block to be made plus a corner extension and then an angle or L-shape plate D' is placed within the mold-box to form the inner sides of the corner-block. It will be seen that by this arrangement the automatic opening and closing of all four walls of the mold-box is not interfered with, and no change of walls is necessary. The bottom plate E' , that is used when corner-blocks are made, in view of the wide separation of the hinge-bars which is necessary when making a corner-block, may be supported or sustained against the strains to which it is subjected by a supplemental bar E^2 , placed beneath it and resting upon the legs A , or it may be given the form shown in Fig. 10, where it is provided with strengthening or reinforcing ribs or bars e^2 , that give it a general rectangular form instead of an L shape or angle form. To form a chamber or passage in the angle or L of the corner-block, the core-carrier, as in my Patent No. 727,427, May 5, 1903, will be provided with a lateral extension or bracket at the proper point for a suitable core, which is detachably connected thereto, so that when corner-blocks are not to be made said core may be removed.

For lifting the newly-formed block from the machine I employ a lifter of well-known construction, consisting of a pole or bar F' , having at each end a handle and hooks G' depending therefrom, the hooks being an inverted-V shape, and one or both legs of each pair of hooks being passed through a slotted plate E' , which limits the swing of the hooks, so that the latter are always kept in position for use, as they are not when, as has been the case heretofore, they have been free to swing on their pivotal connections with the handle-bar.

For the provision upon the blocks of an

Patent 15: H. S. Palmer, *Machine for Making concrete Blocks*, U. S. Patent No. 828,767, Aug. 14, 1906.

828,767

ample mortar-receiving surface at the top thereof, and yet without unduly using material, the tops of the cores are rabbeted or cut away, so as to provide on the interior of the blocks at the top thereof overhanging ledges or projections.

As I have already indicated, some features of my invention may be used in machines that are not automatic, and I also desire to state that in many instances the particular construction which is found in the machine which I have selected to illustrate my invention may be departed from without involving any departure from the scope of my invention.

Having thus described my invention, what I claim is—

1. In a machine for making artificial blocks, the combination of a support, a mold-box, having a wall that is movable to open and close the box, a single adjustable bar upon which said wall is movably mounted, and a removable bottom plate that rests upon said bar.

2. In a machine for making artificial blocks, the combination of a suitable support, a mold-box having pivoted walls, a single bar for each of said walls, adjustably mounted upon said support, whereby the distance between such walls may be varied, and a removable bottom plate supported by said adjustable bars.

3. In a machine for making artificial blocks, the combination of a support, a mold-box having pivoted walls, a single adjustable bar for each of said pivoted walls, and a removable bottom plate supported by said bars.

4. In a machine for making artificial blocks, the combination of a support, a mold-box having a pair of pivoted side walls, a pair of adjustable bars, one for each of said side walls, which is pivoted thereto, a removable bottom plate supported by said bars, and a core or cores, a space being provided between said bars for the accommodation of the core or cores.

5. In a machine for making artificial blocks, the combination of a support, a mold-box having a pair of pivoted side walls, a pair of adjustable bars, one for each of said side walls, which is pivoted thereto, a removable bottom plate supported by said bars, and a vertically-movable core or cores, a space being provided between said bars for the accommodation of the core or cores.

6. In a machine for making artificial blocks, the combination of a mold-box having adjustable elements to adapt it for making blocks of different sizes, holding devices for the adjustable elements, and cooperating surfaces on such holding devices, inclined one relative to the other, to lock or bind the same from movement in the direction in which they are shiftable for adjustment.

7. In a machine for making artificial blocks, the combination of a suitable support, adjustable wall-supporting bars on said support, and clamping devices for said bars engaging said support, the engaging surfaces of the support and clamping devices being inclined.

8. In a machine for making artificial blocks, the combination of a pair of legs, mold-box walls, bars supporting said walls, resting on said legs, and bolts and nuts for clamping the bars to the legs, the nut-engaging under side of the legs being inclined.

9. In a machine for making artificial blocks, the combination of a mold-box having pivoted walls, a vertically-movable core carrier, horizontal rods secured in holes in the core-carrier, and vertical wall-engaging bars supported by said rods.

10. In a machine for making artificial blocks, the combination of a mold-box having pivoted walls, a vertically-movable core-carrier, rods secured in holes in the core-carrier, and vertical wall-engaging bars supported by said rods, and adjustable horizontally thereon.

11. In a machine for making artificial blocks, the combination of a mold-box having pivoted walls, a core-carrier, racks attached to the core-carrier at each end, bars attached to said racks to engage certain of the pivoted walls, rods in the form of shafting attached to the core-carrier, posts rising from said rods, and wall-engaging bars on said posts.

12. In a machine for making artificial blocks, the combination of movable mold-walls, which move in directions that intersect, means for moving them to closed position, and automatic means supplemental to said closing means comprising two cooperating members both of which are supplemental to said closing means, for locking them in a closed position, and unlocking them.

13. In a machine for making artificial blocks, the combination of movable mold-walls, which move in directions that intersect, means for moving said walls to a closed position which includes a movable bar, and a locking device for the walls into and out of engagement with which said bar moves when moved into and out of mold-closing position, respectively.

14. In a machine for making artificial blocks, the combination of movable mold-walls, which move in directions that intersect, means for moving them to a closed position, which includes a bar for engaging one of said walls, and a lug or projection on another wall that interlocks with said bar when the walls are moved to their closed position.

15. In a machine for making artificial blocks, the combination of a pair of movable mold-walls, bars that engage and actuate said mold-walls, a second pair of movable

828,767

7

mold-walls, movable toward and from the ends of the first pair, means for actuating the second pair, and lugs or projections on the walls of the second pair that engage with said bars.

15 16. In a machine for making artificial blocks, the combination of a pair of movable mold-walls, bars that engage and actuate said mold-walls, a second pair of movable
20 mold-walls, movable toward and from the ends of the first pair, means for actuating the second pair, and adjustable lugs or projections on the walls of the second pair that engage with said bars.

15 17. In a machine for making artificial blocks, the combination of a pair of movable mold-walls, adjustable toward and from each other, bars that engage and actuate said mold-walls, a second pair of movable mold-
20 walls, movable toward and from the ends of the first pair, means for actuating the second pair, and adjustable lugs or projections on the walls of the second pair that engage with said bars.

25 18. In a machine for making artificial blocks, the combination of a mold-box having movable walls, a core or cores, means whereby the separation of the core or cores from the newly-formed block may be effect-
30 ed, and adjustable means shiftable to and fixed in definite positions for determining the position of the core or cores within the mold-box, whereby the extent of the passages or chambers produced by the core or cores may
35 be varied.

19. In a machine for making artificial blocks, the combination of a mold-box having movable walls, a core or cores, means whereby the separation of the core or cores from the newly-formed block may be effect-
40 ed, a stop device carried by a mold-wall and coacting with a member of the core-operating means to arrest the movement of the cores, and shiftable to and fixed in definite posi-
45 tions to stop the cores in different positions within the mold-box, whereby the extent of the passages or chambers produced by the cores may be varied.

20. In a machine for making artificial
50 blocks, the combination of a mold-box having movable walls, a movable core or cores, a part connected with the latter that coacts with one of said walls, and a wall-locking device that coacts with said part, and shiftable
55 to different positions to vary the position of the core or cores with reference to the mold-box in the block-forming position of the parts.

21. In a machine for making artificial
60 blocks, the combination of a pair of swinging mold-walls, a bar for each of the same to control the movement thereof, a second pair of swinging mold-walls, means for actuating the same, lugs or projections on the second pair
65 of walls, adjustable to different positions ver-

66 tically to cooperate with said bars, and a movable core or cores connected with said bars.

22. In a machine for making artificial
70 blocks, the combination of a mold-box having a pivoted wall, a shiftable support on which said wall is pivoted, an operating device for said wall, and connections between said device and said support, whereby said device may be shifted when the support is
75 shifted.

23. In a machine for making artificial blocks, the combination of a mold-box having movable walls, and a wall-locking device consisting of a pin having a threaded shank
80 passing through a wall with nuts on opposite sides of the latter on said shank, and a reciprocating part having a hole with which said pin coacts.

24. In a machine for making artificial
85 blocks, the combination of a mold-box having a pivoted wall, a shiftable bar on which said wall is pivoted, an actuating device for said wall, posts supporting said device, and connections between said posts and said bar,
90 whereby when the bar is shifted the posts are shifted.

25. In a machine for making artificial blocks, the combination of a pivoted mold-
95 box wall, a bar to which the same is pivoted, and a pivot-pin detachably connecting the wall and bar having a laterally-extending portion that engages a notch in said bar.

26. In a machine for making artificial
100 blocks, the combination of a mold-box having a movable member or members, a shaft, gearing between the shaft and said member or members through which power from the shaft is transmitted thereto, and a spring
105 connected with the shaft, placed under tension when it is rotated to open the mold-box, and which acts to rotate said shaft to close the mold-box.

27. In a machine for making artificial
110 blocks, the combination of a vertically-movable core-carrier, movable mold-box walls, a shaft from which power is taken to actuate said core-carrier and said walls, and a spring acting to rotate said shaft in one direction.

28. In a machine for making artificial
115 blocks, the combination of a vertically-movable core-carrier, vertically-swinging walls, parts connected with the core-carrier for actuating said walls, a shaft, gearing between the latter and the core-carrier, and a coil-
120 spring mounted on said shaft that is placed under tension when the shaft is turned to lower the core-carrier and open the mold.

29. In a machine for making artificial
125 blocks, the combination of a mold, means for opening the same, a device for storing energy when the mold is opened, said device being restrained from action when the mold is fully open, and means for releasing said device to
130 permit it to act.

Patent 15: H. S. Palmer, *Machine for Making concrete Blocks*, U. S. Patent No. 828,767, Aug. 14, 1906.

S

828,767

30. In a machine for making artificial blocks, the combination of a mold, means for opening the same, a device for storing up energy, and a spring placed under tension when the mold-box is open, said spring being restrained from action when the mold-box is fully open, and means for releasing said spring to permit it to act.
31. In a machine for making artificial blocks, the combination of a mold-box, a material guide or hopper, the latter comprising bars unconnected with each other and movable to and from position for use, and means for holding said bars in fixed positions adjacent to certain of the mold-walls, whereby they serve as guides to direct the material into the mold-box.
32. In a machine for making artificial blocks, the combination of a mold-box having movable side and end walls, a material guide consisting of a bar lying parallel with a side wall, and slidably supported on the end wall, and means to hold said bar in a fixed position adjacent to said side wall for guiding material thereby into the mold-box.
33. In a machine for making artificial blocks, the combination of a mold-box having four walls, two material-engaging bars independent of each other, adapted for cooperation with two of such walls, and situated at the top thereof to guide the material into the mold-box, and supports for said bars on the other two walls.
34. In a machine for making artificial blocks, the combination of a mold-box, consisting of four walls, two of which have upwardly and outwardly inclining flanges at their upper ends, and a bar for each of the other walls having portions to engage said flanges.
35. In a machine for making artificial blocks, the combination of a mold-box, consisting of four walls, two of which are adjustable to vary the size of the blocks to be made, a material-guide, consisting of a bar that is movably mounted, and an adjustable stop for said bar.
36. In a machine for making artificial blocks, the combination of a mold-box, a slidable bar mounted at the top thereof, and stop-pins for said bar, adapted also to secure the bar from movement, said pins being reversible to change their relation to the bar according to the function they are to perform.
37. In a machine for making artificial blocks, the combination of a mold-box, a bar slidably mounted on and supported by the top of the box, and stop pins or projections on the box to engage the bar to fix its position.
38. In a machine for making artificial blocks, the combination of a mold-box, consisting of four walls, two of which are provided at their upper ends with guiding-flanges, a bar slidably mounted on said flanges, and stop-pins on said flanges for said bar that also serve to secure the same to said flanges.
39. In a machine for making artificial blocks, the combination of a mold-box, adjustable bars to support certain of the walls thereof, a bottom plate to support the block to be formed that rests upon said bars, said bottom plate having supporting or strengthening means for the support thereof when said bars are adjusted wide apart.
40. In a machine for making artificial blocks, the combination of a mold adapted to be opened and closed, operating mechanism therefor comprising a reciprocable rod or bar having several holes, a relatively stationary part having a hole to align with any one of the holes in said rod or bar, and a pin adapted to pass through the aligning holes, locking the operating mechanism from movement.
41. In a machine for making artificial blocks, the combination of movable mold-walls, a movable core or cores, parts moving with the core or cores to actuate the movable mold-walls, cam-ribs on the mold-walls for engagement by said parts, said cam-ribs having a formation which permits movement with the core or cores of their parts which cooperate with said cam-ribs, without causing movement of the mold-walls during a portion of the time of movement of the cores, and a mold-locking device comprising two coacting members, one of which moves with the cores to effect the engagement and disengagement of said members.
42. In a machine for making artificial blocks, the combination of a mold-box, a pair of adjustable parallel bars to which a pair of the mold-walls are attached, a removable bottom plate for the mold supported by said bars, and a supplemental bar between the adjustable bars for supporting the removable bottom plate.
43. In a machine for making artificial blocks, a mold-wall having a configuration to produce a rock-face finish on the block, a detachable piece or section for said wall, extending transversely of the wall, having a raised portion to form a surface different from that formed by the face of the mold-wall and having contiguous to the latter a portion similar in configuration to that of the wall, whereby an appearance resembling several panels may be produced.
44. In a machine for making artificial blocks, a mold-wall having a block-forming surface for the purpose of the production of a rock-face finish on the surface of the block, and a piece or section conforming to such surface and detachably connected to the wall, provided with a raised, smooth portion, and having contiguous to the latter a portion similar in configuration to that of the wall.

Patent 15: H. S. Palmer, *Machine for Making concrete Blocks*, U. S. Patent No. 828,767, Aug. 14, 1906.

828,767

9

45. In a machine for making artificial blocks, a mold-wall having a dished or reëntrant face for producing the desired configuration of the block-surface, and a piece or
5 section smaller in size than said face and having on its inner side a surface conforming to and fitting such reëntrant face and detachably connected to the wall, the configuration of the block-surface being produced in part
10 by the reëntrant face of the mold-wall and said detachable piece or section.

46. In a machine for making artificial

blocks, the combination of a mold-box having end walls and adjustable side walls, and a material guide or hopper having members 15 supported by said end walls and adjustable toward and from each other to vary the size of the hopper.

In testimony that I claim the foregoing I have hereunto set my hand.

HARMON S. PALMER.

Witnesses:

CHAS. J. WILLIAMSON,
JOSEPHINE L. LAWLOR.

Patent 15: H. S. Palmer, *Machine for Making concrete Blocks*, U. S. Patent No. 828,767, Aug. 14, 1906.

No. 822,333.

PATENTED JUNE 5, 1906.

I. E. YARNELL.
CONCRETE BUILDING BLOCK MACHINE.

APPLICATION FILED MAY 13, 1905.

4 SHEETS—SHEET 1

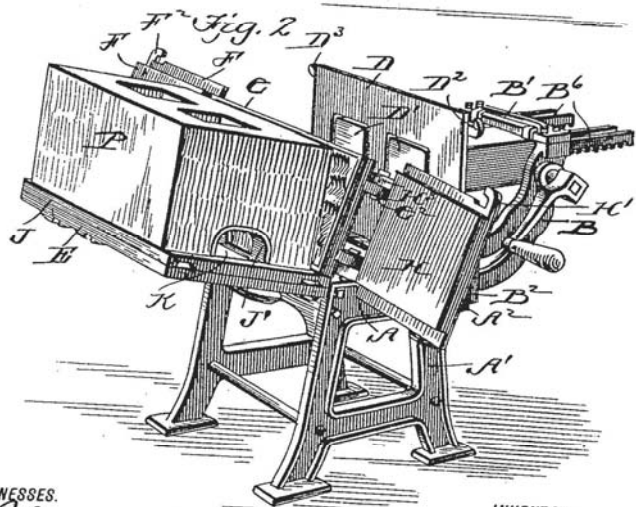
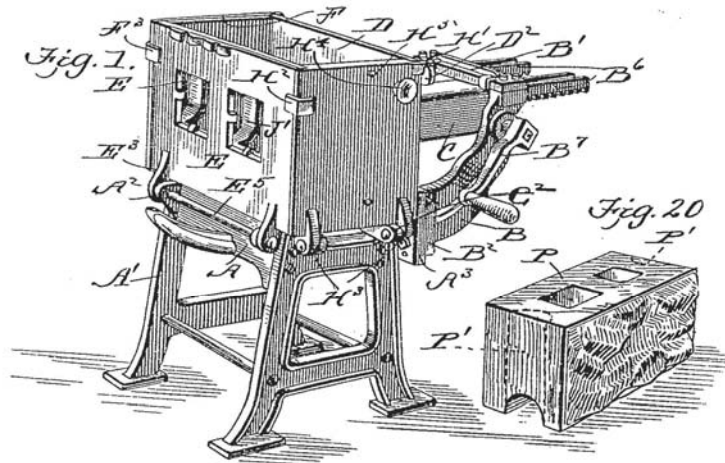

WITNESSES.
Wm. Blundell
E. B. McBeth

INVENTOR
I. E. Yarnell.
BY
Chas. Brock
ATTORNEYS

Patent 16: I. E. Yarnell, Concrete Building Block Machine, U. S. Patent No. 822,333. June 5, 1906.

849-64

PARATUS

an

No. 822,333.

PATENTED JUNE 5, 1906.

I. E. YARNELL.
CONCRETE BUILDING BLOCK MACHINE.

APPLICATION FILED MAY 13, 1905.

4 SHEETS-SHEET 2.

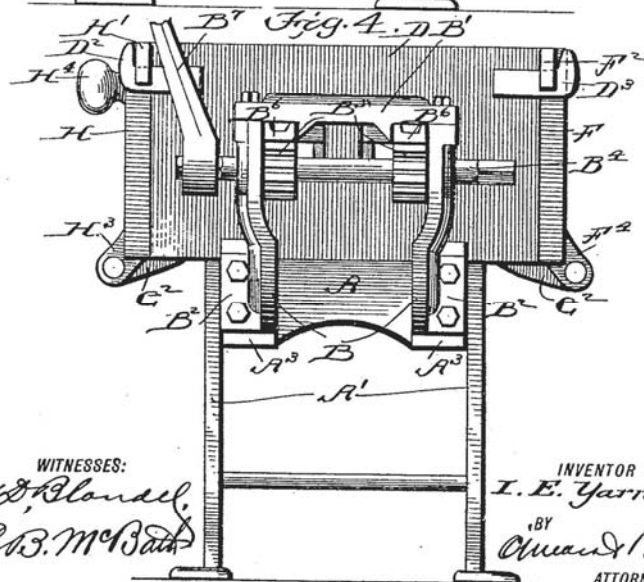
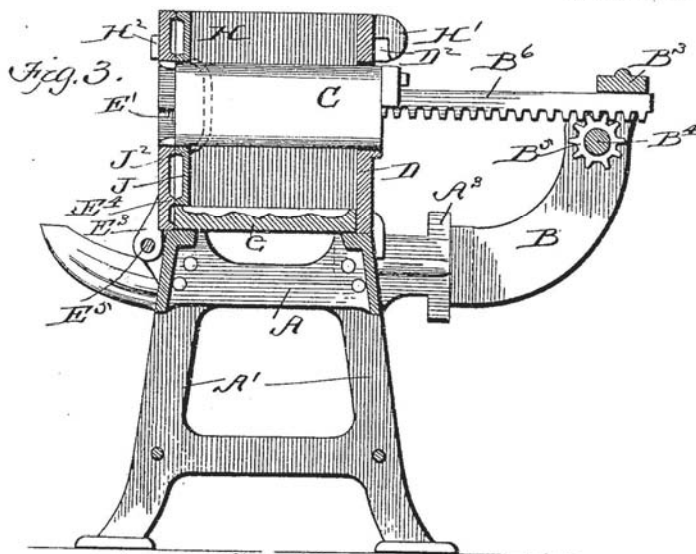

WITNESSES:
M. D. Blundell,
E. B. McBeth

INVENTOR
I. E. Yarnell.
 BY
Oliver & Brock
 ATTORNEYS

Patent 16: I. E. Yarnell, *Concrete Building Block Machine*, U. S. Patent No. 822,333. June 5, 1906.

No. 822,333.

PATENTED JUNE 5, 1906.

I. E. YARNELL.
CONCRETE BUILDING BLOCK MACHINE.

APPLICATION FILED MAY 13, 1905.

4 SHEETS—SHEET 3.

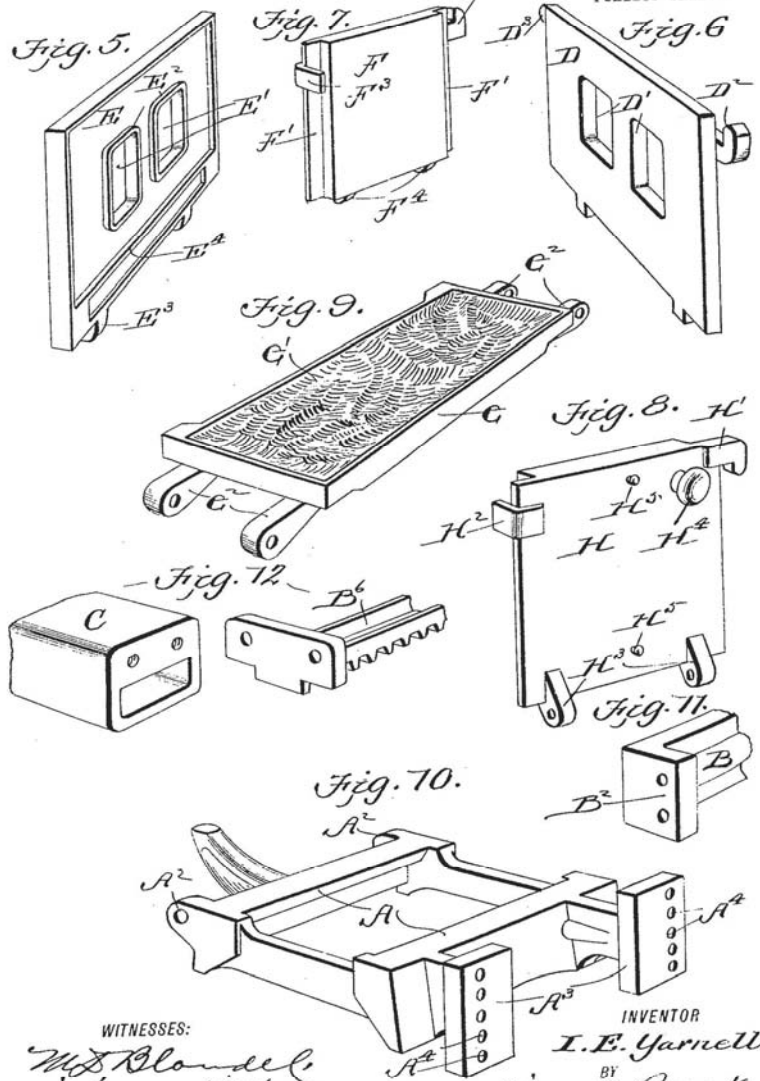

WITNESSES:
W.D. Blondell,
E.B. McBeth,

INVENTOR
I.E. Yarnell,
 BY
Chas. Brock
 ATTORNEYS

Patent 16: I. E. Yarnell, *Concrete Building Block Machine*, U. S. Patent No. 822,333. June 5, 1906.

822,333

D, and on its inner face a flange E² surrounds the openings E'. Along the lower edge of the plate E are depending ears perforated to align with the ears A² of the frame A, and a rod E³, passing through the ears A² and E³, hinge the rear plate E to the frame A. Adjacent its lower edge and on its inner face the plate E has a longitudinal rib E⁴ formed thereon. The front and rear walls rest on the frame A, and the bed-plate G also rests on said frame between the plates D and E. The end plates F and H rest on and transverse to the bed-plate G, and the ears F⁴ align with the ears G² at one end of the bed-plate, and the ears H² align with the ears G² at the opposite end of the bed-plate, a suitable pivot pin or pintle connecting them.

It will now be obvious that the side and end plates of the mold are readily detachable and may also be swung open, as shown in Fig. 2.

In operating the machine the parts are placed in the position shown in Fig. 1. An inner rear plate J is placed in position resting on the rib E⁴. This plate is longitudinally slotted, as shown at J', and on its inner face has three inwardly-curved bars J², arranged transverse to the slot J' and spanning the slot. When in place, the slot J' registers with the openings E' and the bars J² are upon one side of said opening, the central bar J² being between the openings E'. The machine is then filled two-thirds full of concrete and tamped, and the cores C are then driven through the mass by rotation of the handle B'. The mold is then filled and the tamping operation resumed. The block is subsequently trimmed down with an edging-tool.

In order to make various sizes and shapes of blocks, supplemental bottom and end plates are provided, which fit within the molding-frame previously described. In Fig. 15 I have shown an end plate K having a central curved ridge K' stamped thereon. When plates K are set in each end of the mold, grooves P' are formed in the ends of a block P, as shown by the dotted lines in Fig. 20, whereas with the plates K omitted the stone would appear as shown in full lines in said figure.

The face of the stone is formed by the bed-plate G, and supplemental bed-plates may rest on this bed-plate, not only varying the size of the block in thickness, but also changing the face finish. In Fig. 16 I show a sup-

plemental bed-plate L having transverse grooves L' and in Fig. 17 a bed-plate M having beveled sides M', thereby giving a smooth face and beveled-edge stone or block. In Figs. 18 and 19 are shown smaller bed-plates, used with supplemental end plates, the plate O being smooth and having beveled edges and the plate O' being rough-dressed and similar to the bed-plate G, except in size.

In making a block of less than the usual size but one core is required, and by moving the pinion B² along the shaft B⁴, so as to throw it out of engagement with the rack, only one core C is operated. Reference has been made to threaded apertures H³, through which a suitable screw can work. These are for the purpose of adjusting the supplemental end plate resting in the mold adjacent the end plate H, as will be readily understood. In making blocks of various size it is of course necessary that the core or cores be vertically adjustable, as heretofore described. When solid blocks are made for veneering, the cores C are not employed.

The machine herein described and shown in the drawings will make six sizes of blocks—two solid and four hollow.

Having thus fully described my invention, what I claim as new, and desire to secure by Letters Patent, is—

1. The combination with a frame, a mold formed of detachable side, bed and end plates adapted to rest on the frame, means for locking the side and end pieces together and to the bed-plate, vertically-adjustable brackets carried by the frame, a shaft carried by the brackets, pinions thereon, rack-bars engaging the pinions, and cores adapted to work in the mold and connected to the rack-bars.

2. A machine of the kind described comprising a bed-plate, end plates hinged thereto, front and rear plates resting on the bed-plate and locked to the end plates, aligning opening in the said front and rear plates, vertically-adjustable brackets in advance of the front plate, a shaft carried by the brackets, pinions slidably carried by the shaft, racks in engagement with the pinions, and cores carried by the racks, as and for the purpose set forth.

ITHAMER E. YARNELL.

Witnesses:

G. A. LAMB,
RUPERT HOLLAND.