

## Polymer-bonded NiZn ferrite magnetic cores mixed with titanium (IV) isopropoxide (C<sub>12</sub>H<sub>28</sub>O<sub>4</sub>Ti)

K. W. E. Cheng, Kai Ding, S. L. Ho, W. N. Fu, Junhua Wang et al.

Citation: *J. Appl. Phys.* **109**, 07A514 (2011); doi: 10.1063/1.3562038

View online: <http://dx.doi.org/10.1063/1.3562038>

View Table of Contents: <http://jap.aip.org/resource/1/JAPIAU/v109/i7>

Published by the [American Institute of Physics](#).

---

### Related Articles

Managing magnetic force applied to a magnetic device by a rotating dipole field  
*Appl. Phys. Lett.* **99**, 134103 (2011)

Design and performance of a pulse transformer based on Fe-based nanocrystalline core  
*Rev. Sci. Instrum.* **82**, 084703 (2011)

High performance bonded neo magnets using high density compaction  
*J. Appl. Phys.* **109**, 07A743 (2011)

Micro-structured ferromagnetic tubes for spin wave excitation  
*J. Appl. Phys.* **109**, 07D333 (2011)

Reducing audible noise for distribution transformer with HB1 amorphous core  
*J. Appl. Phys.* **109**, 07A318 (2011)

---

### Additional information on J. Appl. Phys.

Journal Homepage: <http://jap.aip.org/>

Journal Information: [http://jap.aip.org/about/about\\_the\\_journal](http://jap.aip.org/about/about_the_journal)

Top downloads: [http://jap.aip.org/features/most\\_downloaded](http://jap.aip.org/features/most_downloaded)

Information for Authors: <http://jap.aip.org/authors>

### ADVERTISEMENT

**AIP**Advances

*Submit Now*

**Explore AIP's new  
open-access journal**

- **Article-level metrics  
now available**
- **Join the conversation!  
Rate & comment on articles**

## Polymer-bonded NiZn ferrite magnetic cores mixed with titanium (IV) isopropoxide ( $C_{12}H_{28}O_4Ti$ )

K. W. E. Cheng,<sup>a)</sup> Kai Ding, S. L. Ho, W. N. Fu, Junhua Wang, and Shuxiao Wang  
*Department of Electrical Engineering, The Hong Kong Polytechnic University, Kowloon, Hong Kong*

(Presented 18 November 2010; received 12 October 2010; accepted 8 December 2010; published online 14 April 2011)

For decades, the technology and engineering domains have been constantly demanding high-performance magnetic materials. Recently, polymer bonded NiZn ferrite magnetic materials mixed with titanium (IV) isopropoxide ( $C_{12}H_{28}O_4Ti$ ) for power converter applications have been found to be very promising in reducing the loss, cost, and material weight when compared to their conventional counterparts using air-core technology, conventional soft ferrites, and powder iron. The proposed magnetic core is flexible in both size and shape and is not brittle. The design of a high-frequency transformer for a 100 W two-transistor forward converter-based electric vehicle battery charger operating at a switching frequency of 360 kHz is reported in this paper. Printed circuit board prototyping and experimental results as well as comparisons with conventional converters are provided to validate the application feasibility of the proposed materials. © 2011 American Institute of Physics. [doi:10.1063/1.3562038]

The research and development for power electronic converters is making phenomenal advancements. Major drivers for this increasingly topical research include growth of green energy and energy-saving products, electrical vehicles (EV), mobile devices, liquid crystal display television, etc. As the provision of high-quality magnetic material is critical in the design of power converters for high-frequency transformers, designers are paying increasing attention to searching for materials with excellent magnetic properties.

The design of magnetic power converters is dependent on many factors, including permeability, loss factor, size, and shape of the magnetic materials. Specifically, the loss in magnetic materials usually accounts for around 30%–40% of the total loss in a converter. Conventional magnetic materials, such as ferrites and molybdenum permalloy powder, are known for their low loss characteristics and high-frequency operation. Thus, these magnetic materials are commonly used in inductors and transformers of high-power converters. However, these magnetic materials suffer from a number of drawbacks, such as bulkiness, brittleness, and high cost.

The losses in power conversion can be divided into conductor loss and core loss. The conductor loss, or winding loss, is the resistive loss due to the current passing through windings. Due to the skin effect in conductors at high frequency, this loss can increase very significantly as the frequency increases. On the other hand, core loss is due to hysteresis, eddy-current loss, and/or residue loss of the magnetic materials. Hysteresis loss and eddy-current loss can be reduced by using powder iron core for high-frequency application. The introduction of polymer into the conventional core could also reduce the eddy-current loss and extend their applications to a broader range in high-frequency applications.

Recently, polymer-bonded magnetic materials have attracted a great deal of attention in the fields of magneto-

electrics and magneto-optics. These materials are composed of polymer matrices and magnetic powders, which can be produced using traditional polymer processing methods.<sup>1–6</sup> Polymer-bonded magnetic materials offer significant advantages over conventional materials.<sup>7–9</sup> For instance, polymer-bonded magnetic materials can be molded more easily, lowering the costs of both manufacturing and quality control. Nonetheless, the polymer-bonded magnetic materials have not typically been applied in power conversion devices. This is because the tremendous work required in terms of optimization and permeability study has indeed deterred these materials from being widely exploited in commercial products.

Similar polymer-bonded magnetic material has been reported<sup>10</sup> in the development of planar transformers and inductors. In these prior art composites reported, no excluder and coupling agent have been included and their power levels are small. However, for power application over 100 W, for example, the characteristics and performance of the materials have to be examined properly. This paper will investigate the application of the proposed material as described in below to high-frequency power conversion.

The proposed magnetic composition for power conversion includes a thermoplastic polymer and magnetic powder.

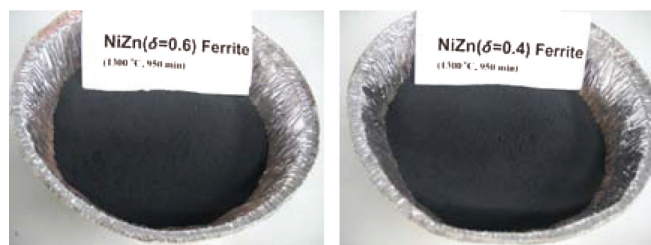

FIG. 1. (Color online) Typical photos for NiZn ferrite materials (1300 °C, 950 min,  $\delta = ZnO/Fe_2O_3$ ).

<sup>a)</sup>Electronic mail: eecheng@polyu.edu.hk.



FIG. 2. (Color online) Typical images of the extrusive composites.

The thermoplastic polymer can be taken from the group consisting of poly (methyl methacrylate) (PMMA) and polyethylene. The magnetic powder can be taken from the group consisting of nickel, cobalt, NiZn ferrite, and MnZn ferrite. Optionally, a coupling agent of titanium (IV) isopropoxide ( $C_{12}H_{28}O_4Ti$ ) is included in the composition. For example, a typical composition contains about 10 wt. % of the thermoplastic polymer and about 90 wt. % of the magnetic powder. The magnetic powder itself also contains about 15 wt. % of the coupling agent.

To produce the polymer-bonded magnetic material, appropriate amounts of  $Fe_2O_3$ , NiO, and ZnO in different mole ratios (50:20:30, 50:30:20, or 50:40:10, Fig. 1) can be vigorously mixed in a high-speed blender for about 2 min. The mixture is then sintered in a high-temperature calcination furnace. The furnace is heated at a rate of  $8^\circ C/min$  to  $1300^\circ C$  and this temperature is maintained for 950 min. The melted mixture is then taken out immediately to an ambient temperature of about  $20^\circ C$  so as to cool down the composition to room temperature rapidly. The cooled mixture is then crushed in a high-speed blender to become magnetic powders.

To remove most of the moisture in the mixture, the PMMA pellets are dried in an oven at about  $60^\circ C$  for about 6 h. The magnetic powders are also dried in an oven at about  $60^\circ C$  for about 4 h. To modify the surface properties of the magnetic powders, these powders are vigorously mixed with titanium (IV) isopropoxide ( $C_{12}H_{28}O_4Ti$ ) in a high-speed blender. The dried magnetic powders contain about 15 wt. % of  $C_{12}H_{28}O_4Ti$ . The mixture is further dried in an oven at about  $60^\circ C$  for about 3 h. Such a modification improves the compatibility between the magnetic powders and the polymer, which in turn improves the properties of the composite.

The dried PMMA pellets are mixed with Stearic acid ( $C_{18}H_{36}O_2$ ) in a high-speed blender to form polymer powders with appropriate size. The dried PMMA contains about 2 wt. % of  $C_{18}H_{36}O_2$ . The modified magnetic powders and polymers



FIG. 3. (Color online) Typical photos of polymer-bonded magnetic cores (ring shape, EI shape, and U shape).

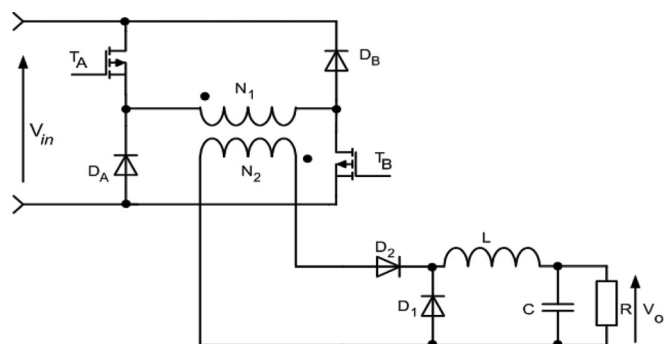

FIG. 4. Two-transistor forward converter.

are then vigorously premixed in a high-speed blender. This mixture is blended further using a single-screw extruder operating at an appropriate rotation speed. The temperature settings are selected as: Zone 1 at  $210^\circ C$ , Zone 2 at  $230^\circ C$ , Zone 3 at  $265^\circ C$ , and Zone 4 at  $260^\circ C$ . It is worth noting that the extrusion becomes difficult at low temperature, while high temperature would also cause inconsistency in material properties. Figure 2 shows typical images of the extrusive composites. Figure 3 shows the polymer-bonded magnetic cores.

To evaluate the performance and feasibility of the polymer-bonded magnetic transformers, an 100 W polymer-bonded magnetic two-transistor forward converter-based EV battery charger is designed and implemented.

The two-transistor forward converter as shown in Fig. 4 is operated by two transistors and the voltage across the transistor is always within the supply voltage  $V_{in}$ . No double voltage-rating requirements on the components are needed in this circuit. In the off state, both transistors are subjected to only the dc input voltage rather than  $2V_{in}$  as in single-ended converters. Furthermore, at turnoff, there is no leakage inductance spike.<sup>11</sup> This type of converter topology is commonly used for power ratings under 200 W. The voltage converter ratio is  $DN_2/N_1$ . There is no shoot-through danger as the two transistors are not connected in series across the dc supply. The downside is that more components are needed. The maximum duty ratio is 50% because of the requirement for volt-second balance of the transformer.<sup>12–14</sup>

Consider the requirement for an EV battery charger rated at 100 W to deliver a single output of 30 V, 3.3 A. The

TABLE I. Electrical specification of a two-transistor forward converter.

Description	Symbol	Min	Typ	Max	Units
<b>Input</b>					
Voltage	$V_{in}$	85	110	137	VAC
Frequency	$f_{line}$	47	50	60	Hz
<b>Output</b>					
Output voltage	$V_{out}$	29	30	31	V
Output ripple	$V_{ripple}$	...	...	420	mV
Output current	$I_{out}$	0.13	...	3.3	A
Output power	$P_{out}$	...	...	100	W
Switching frequency	$f_s$	...	360	...	kHz
Efficiency	$\eta$	...	87	...	%
Ambient temperature	$T_{AMB}$	0	...	40	$^\circ C$



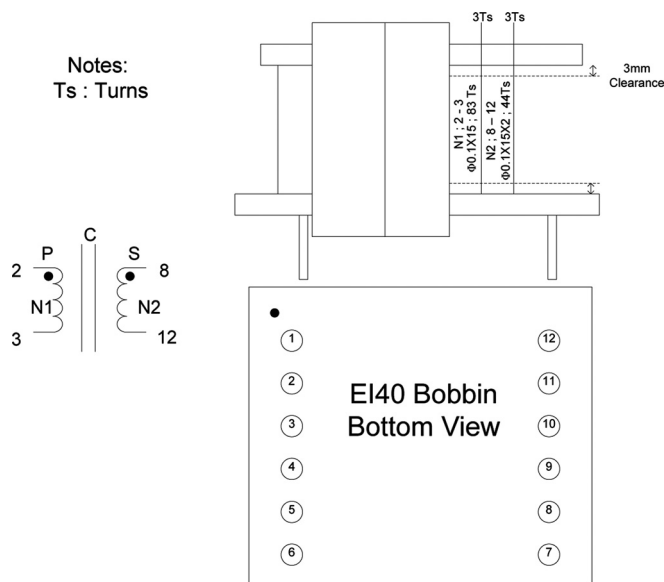

FIG. 5. Transformer specification of the polymer-bonded two-transistor forward converter.

switching frequency is 360 kHz; the electrical specification of the converter is given in Table I.

The prototype of the two-transistor forward converter is built utilizing a high-speed PWM controller UC3825 as shown in Fig. 4. The specification of the transformer is shown in Fig. 5. Two MOSFET IRF840s are used as the main switches at a switching speed of 360 kHz. This converter has an ac input of 110 V and a dc output of 30 V. The output voltage can be adjusted as required. Figure 6(a) shows the measured waveforms of the primary voltage and secondary voltage of the transformer. The gate driving signal and drain to source voltage are shown in Fig. 6(b). Figure 7 shows the printed circuit board (PCB) prototype of the converter. The power converter reaches an efficiency of 87.3% at 100 W. Another 100 W two-transistor forward converter using conventional materials 3C90 with an EI 40 core has also been fabricated for comparison purposes. Under the same experimental condition, the measured efficiency of the conventional converter is around 86.6% at full power at a switching frequency of 100 kHz. In other words, the performance of polymer-bonded magnetic two-transistor forward converter is competitive with those of a converter using traditional core.

A polymer-bonded magnetic material composed of polymer matrices and special magnetic powder has been

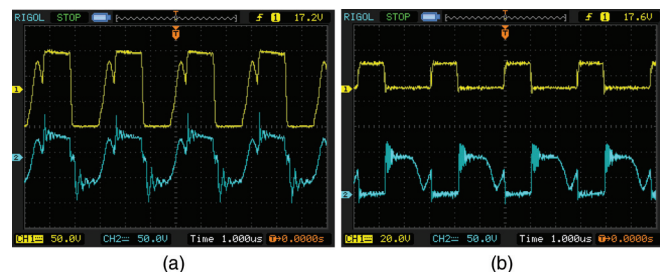

FIG. 6. (Color online) Measured waveforms for the two-transistor forward converter using polymer-bonded magnetic core. (a) CH1: Primary voltage of transformer, 50 V/div, time: 1  $\mu$ s/div; CH2: Secondary voltage of transformer, 50 V/div. (b) CH1: Gate driver signal, 20 V/div; CH2: Drain to source voltage, 50 V/div, time: 1  $\mu$ s/div. ("Div" means: per division).



FIG. 7. (Color online) PCB prototype of the two-transistor forward converter.

developed. In using the materials, light weight, low cost, and nonbrittle magnetic cores of flexible shapes and sizes are realized. The EI 40 polymer-bonded magnetic core has also been fabricated and used in building a 100 W, two-transistor forward converter-based EV battery charger which has an 110 V ac input and a 30 V dc output.

The proposed converter using these materials are light, compact, nonbrittle, and easy to fabricate when compared to converters fabricated using conventional materials. The conversion efficiency of the proposed converter is comparable, if not slightly higher, than that of converters using EI 40 polymer-bonded magnetic core. Successful implementation of polymer-bonded magnetic material-based two-transistor forward converter therefore is a good showcase to demonstrate the feasibility of using these materials in power conversion application for reducing the overall weight and size of conventional converters.

<sup>1</sup>K. W. E. Cheng and C. Y. Tang *et al.*, IEEE Annual Power Electronics Specialists Conference, Cairns, Queensland, Australia, 2002, Vol. 3, pp. 1254–1259.

<sup>2</sup>X. F. Wang, D. Lee, and Z. L. Jiang, *J. Appl. Phys.* **99**, 08-513 (2006).

<sup>3</sup>J. Xiao and J. Otaigbe, *J. Alloys Compd.* **309**, 100 (2000).

<sup>4</sup>J. Xiao and J. U. Otaigbe, *J. Mater. Res.* **14**, 2893 (1999).

<sup>5</sup>J. Xiao and J. U. Otaigbe, *Polym. Compos.* **21**, 332 (2000).

<sup>6</sup>J. Xiao, J. U. Otaigbe, and D. C. Jiles, *J. Magn. Magn. Mater.* **218**, 60 (2000).

<sup>7</sup>K. Ding, K. W. E. Cheng, W. T. Wu, and D. H. Wang, Second International Conference on Power Electronics Systems and Applications Proceedings, Hong Kong, 13–14 November 2006, pp. 87–89.

<sup>8</sup>W. T. Wu, Y. W. Wong, and K. W. E. Cheng, Second International Conference on Power Electronics Systems and Applications Proceedings, Hong Kong, 13–14 November 2006, pp. 73–76.

<sup>9</sup>K. W. Cheng, Y. W. Wong *et al.*, U.S. Patent Application No. 12/039,592, filing date: Feb. 28, 2008.

<sup>10</sup>S. Egelkraut, M. März, and H. Ryssel, Proceedings of the CIPS 2008 (ETG-FB 111) Conference, 5th International Conference on Integrated Power Electronics Systems, Nuremberg, Germany, 11–13 March 2008.

<sup>11</sup>K. W. E. Cheng, *Classical Switched Mode and Resonant Power Converters*. (The Hong Kong Polytechnic University, Hong Kong, 2002).

<sup>12</sup>K. Billings, *Switching Mode Power Supply Handbook*, 2nd ed. (McGraw Hill, New York, 1999).

<sup>13</sup>C. W. T. McLyman, *Transformer and Inductor Design Handbook*, 3rd ed. (Kg Magnetics, Idyllwild, 2004).

<sup>14</sup>T. L. Skvarenina, *The Power Electronics Handbook* (CRC Press, Boca Raton, 2001).