

External injection-seeding scheme with selected wavelength feedback to the master Fabry–Perot laser diode for wavelength-tunable optical short-pulse generation

Xiaohui Fang

Department of Electrical Engineering, The Hong Kong Polytechnic University, Hung Hom, Kowloon, Hong Kong, China, and Optoelectronic Research Centre, Department of Electronic Engineering, City University of Hong Kong, Hong Kong, China

Dong-Ning Wang and Wei Jin

Department of Electrical Engineering, The Hong Kong Polytechnic University, Hung Hom, Kowloon, Hong Kong, China

Pak L. Chu, Jie Li, and Yunqi Liu

Optoelectronic Research Centre, Department of Electronic Engineering, City University of Hong Kong, Hong Kong, China

Received March 3, 2005; revised July 6, 2005; accepted August 27, 2005

An external injection-seeding scheme with selected wavelength feedback to the master Fabry–Perot laser diode is developed to improve the side-mode suppression ratio (SMSR) and extend the wavelength tuning range of the injection-seeded optical short pulses. A SMSR of higher than 31 dB over a wavelength tuning range of 20.4 nm has been obtained. For a SMSR of higher than 40 dB, the wavelength tuning range achieved is 13.8 nm. The system is simple and can operate at arbitrary repetition frequency. © 2006 Optical Society of America
OCIS codes: 140.5960, 140.3520, 140.3600.

1. INTRODUCTION

Wavelength-tunable optical short pulses generated from semiconductor laser diodes have many applications in optical fiber communications and fiber optical sensors owing to their compact size and low cost. The Fabry–Perot (FP) laser diode is one of the most economical semiconductor lasers for the generation of optical short pulses in a relatively wide wavelength range.^{1–9} To produce the optical short pulses at arbitrary repetition frequency, researchers have adopted an external injection-seeding scheme in which a high-cost external-cavity tunable laser is usually used as the master laser source to seed a slave FP laser diode.^{4–6} A low-cost FP laser diode together with a wavelength-selective component, such as a FP filter or a fiber Bragg grating, may also be used in external injection seeding.^{7–9} However, as most of the power from the master FP laser diode is filtered out and the selected wavelength component has relatively low intensity, the output pulses obtained exhibit a relatively small side-mode suppression ratio⁷ (SMSR). Although the selected wavelength component can be amplified by use of an erbium-doped fiber amplifier (EDFA) to increase the SMSR, such an increase is still limited as the side mode may also be amplified simultaneously.^{8,9} Moreover, the wavelength tuning is on a mode-to-mode basis, and the tuning range is lim-

ited by the small gain bandwidth of a dc-biased FP master laser diode.⁸

In this paper we present an external injection-seeding scheme for continuously wavelength-tunable optical short-pulse generation by use of a feedback ring to the master source to enhance the selected wavelength intensity and improve the SMSR of the output pulses. The theory that explains continuous wavelength tuning is presented first and is followed by an experimental demonstration. In the system, a dc-biased FP laser diode is used as the master source, and a gain-switched FP laser diode is used as the slave laser. The SMSR of the output optical short pulse is higher than 31 dB over the wavelength tuning range of 20.4 nm. The system is simple and can be operated at arbitrary repetition frequency.

2. THEORY FOR THE CONTINUOUS WAVELENGTH TUNABILITY

When the single-mode continuous-wave (cw) output from a master laser is injected into the cavity of a gain-switched FP slave laser, the multimode field rate equations for the amplitude and the phase of the optical field and the carrier number in the active region of the slave laser are^{10,11}

$$\frac{dE_i(t)}{dt} = \frac{1}{2} \left[\frac{g(N - N_0)}{1 + sE_i^2(t)} - \gamma \right] E_i + k_m \cos(\phi) + \frac{2\beta N}{E_i} + \sqrt{\beta N} \xi_{E_i}(t), \quad (1)$$

$$\frac{d\phi_i(t)}{dt} = \frac{\alpha}{2} \left[\frac{g(N - N_0)}{1 + sE_i^2(t)} - \gamma \right] - \Delta\omega - \frac{k_m E_m}{E_i} \sin(\phi_i) + \frac{\sqrt{\beta N}}{E_i} \xi_{\phi_i}(t), \quad (2)$$

Table 1. Semiconductor Laser Parameters

Parameter	Meaning	Value
g	Differential gain	$5.6 \times 10^4 \text{ s}^{-1}$
γ	Losses	$4 \times 10^{11} \text{ s}^{-1}$
γ_e	Inverse carrier lifetime	$5 \times 10^8 \text{ s}^{-1}$
N_0	Transparency value for the carrier number	6.8×10^7
β	Spontaneous emission rate	$1.1 \times 10^4 \text{ s}^{-1}$
α	Linewidth enhancement factor	5
s	Gain compression factor	0.7×10^{-6}
τ_L	Cavity round-trip time	$7 \times 10^{-12} \text{ s}$
R_2	Facet reflectivity	$7 \times 10^{-12} \text{ s}$
η_{ext}	Coupling losses	1

$$\frac{dN}{dt} = c - \gamma_e N(t) - \frac{g[N(t) - N_0]}{1 + s \sum_{i=-M}^M |E_i(t)|^2} \sum_{i=-M}^M |E_i(t)|^2. \quad (3)$$

The amplitude of the i th mode of the optical field is normalized in such a way that $|E_i(t)|^2$ gives the photo number of the i th mode inside the slave laser cavity. The typical values of the parameters are listed in Table 1. The random spontaneous emission process is modeled as a complex Gaussian white-noise term, $\xi(t)$; such a term has zero

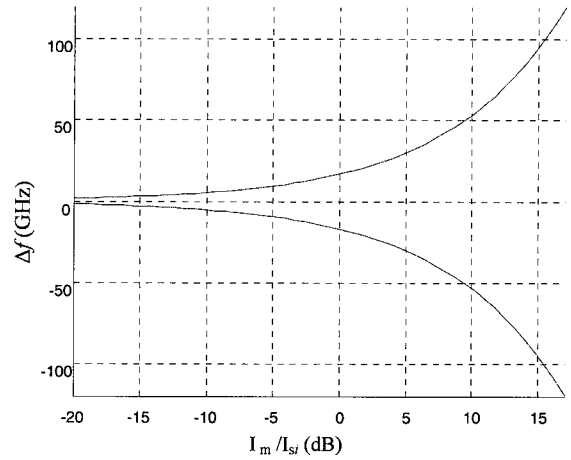

Fig. 1. Frequency locking range versus injection ratio I_m/I_{s_i} .

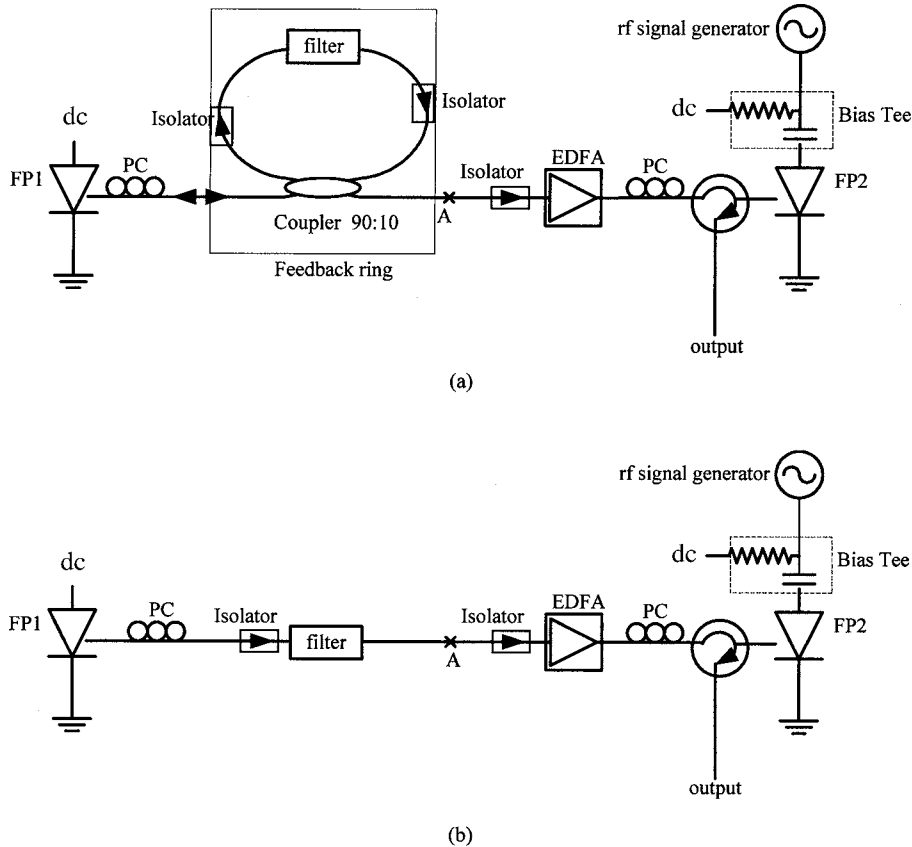

Fig. 2. (a) Experimental setup for external injection seeding with feedback to the master FP laser source. (b) Experimental setup for external injection seeding without feedback to the master FP laser source.

mean, and its autocorrelation $\langle \xi(t)\xi^*(t') \rangle = 2\delta(t-t')$. When the frequency for the single-mode output of the master laser is ω_m and that for one of the free-running modes of the FP slave laser diode is ω_s , the frequency mismatch is considered in the field rate equation through frequency detuning $\Delta\omega = \omega_m - \omega_s$. k_m is the parameter controlling the injection strength, which is given by¹¹

$$k_m = \frac{1}{\tau_L} \frac{\sqrt{1-R_2}}{\sqrt{R_2}} \eta_{\text{ext}}, \quad (4)$$

where τ_L is the slave cavity's round-trip time. η_{ext} is the coupling losses' parameter, which is determined by the power losses arising from filtering, mode matching, and the losses other than that introduced by the laser facet. R_2 is the facet reflection of the slave laser.

Steady states exist inside a locking range given by detunings $|\Delta\omega| < \Delta\omega_L$, where

$$\Delta\omega = \frac{k_m E_m}{E_{s_i}} \sqrt{1 + \alpha^2} = k_m \sqrt{\frac{I_m}{I_{s_i}} (1 + \alpha^2)}. \quad (5)$$

In these steady states, when the slave laser oscillates at the same frequency as the master laser, the slave laser is said to be locked. One obtains the steady-state values E_{s_i} , ϕ_{s_i} , and N_s by setting the corresponding time derivatives to zero. $I_m = E_m^2$ is the injection optical intensity of the master laser, and $I_{s_i} = E_{s_i}^2$ is the optical intensity of the i th mode of a free-running gain-switched slave laser. The frequency locking range versus the injection ratio I_m/I_{s_i} is shown in Fig. 1. The mode spacing of the FP slave laser used in the experiment is 1.1 nm. It can be seen from Fig. 1 that if the injection ratio is increased, which leads the locking range to reach 0.55 nm (half of the mode spacing, ~ 68.75 GHz), a continuous wavelength locking can be

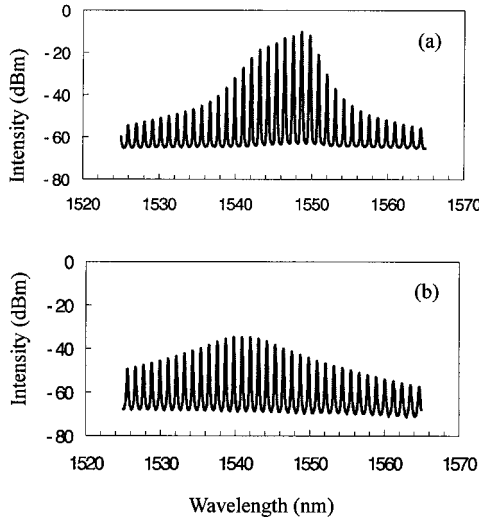

Fig. 3. (a) Multimode output spectrum of dc-biased FP1. (b) Multimode output spectrum of gain-switched FP2.

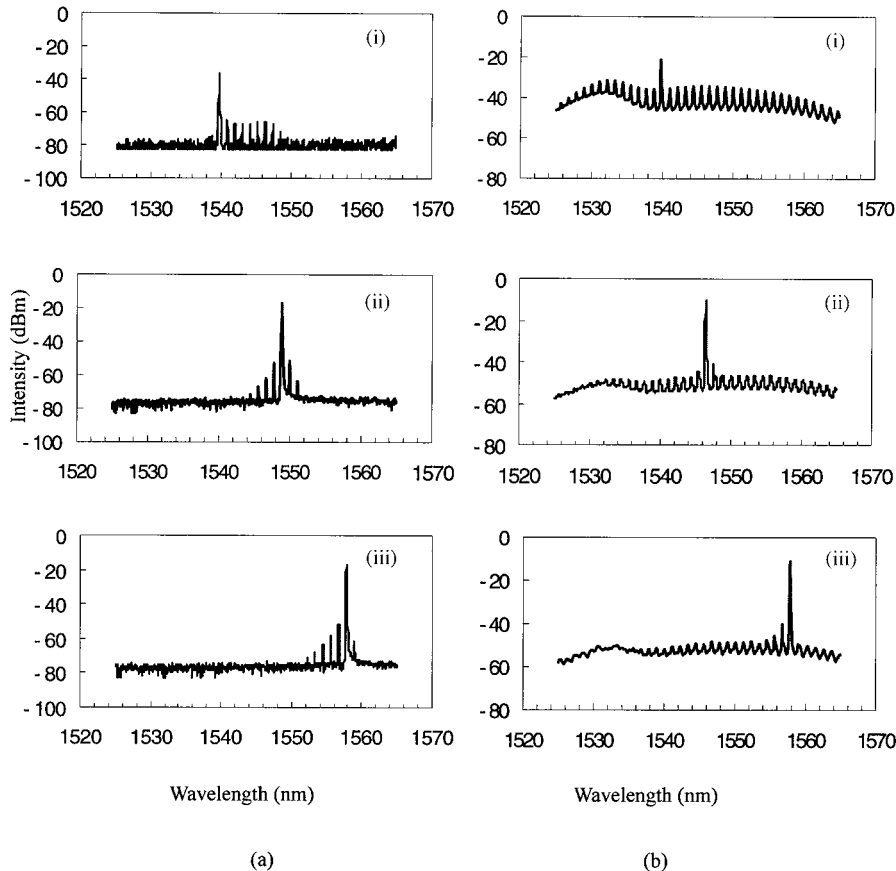

Fig. 4. (a) dc-biased FP1 output spectra at point A, in the system shown in Fig. 2(b) at wavelengths of (i) 1539.8, (ii) 1548.9, and (iii) 1557.8 nm. (b) The output spectra of injection-seeded single-wavelength optical pulses without feedback to FP1 at wavelengths of (i) 1539.8, (ii) 1548.9, and (iii) 1557.8 nm.

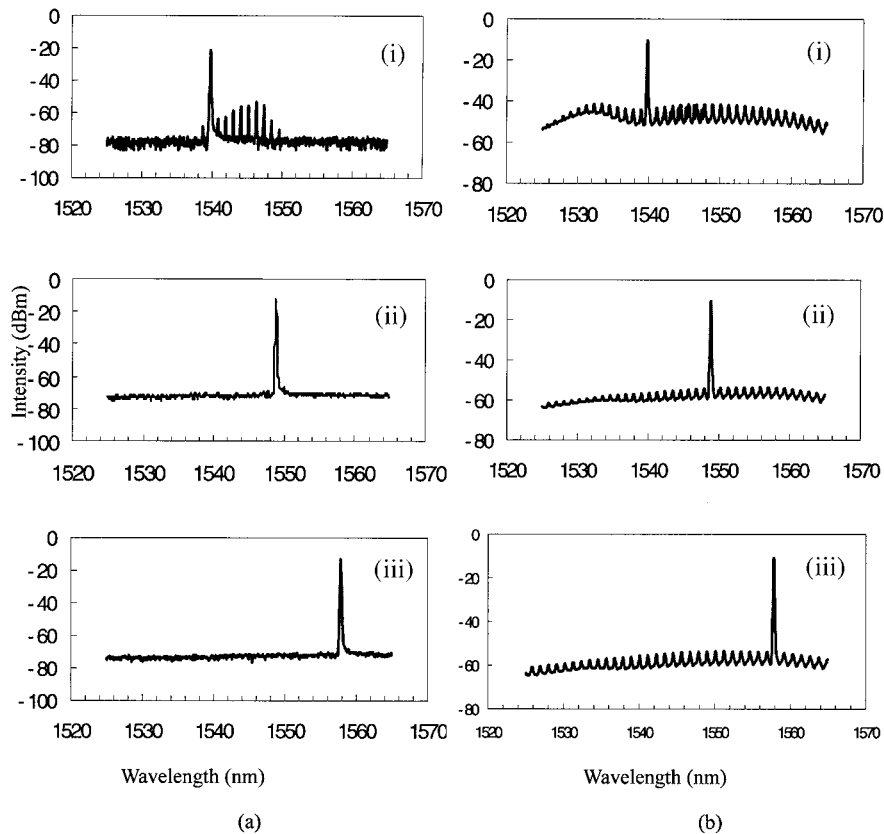

Fig. 5. (a) dc-biased FP1 output spectra at point A, in the system shown in Fig. 2(a) at wavelengths of (i) 1539.8, (ii) 1548.9, and (iii) 1557.8 nm. (b) The output spectra of injection-seeded optical single-wavelength pulse with a feedback to FP1 at wavelengths of (i) 1539.8, (ii) 1548.9, and (iii) 1557.8 nm.

achieved between the two adjacent modes of the FP slave laser.

3. EXPERIMENT

The experimental setup for an external injection-seeding scheme with a feedback ring is shown in Fig. 2(a). The master source, FP1, is a commercial FP laser diode; it has a central wavelength of ~ 1543 nm, mode spacing of ~ 1.10 nm, and threshold current of ~ 10 mA and is dc biased at 29 mA. The multimode cw output of FP1 was first passed through a tunable FP filter with a bandwidth of 4.76 GHz and a free spectral range of 5713 GHz, via a 90:10 coupler. Ten percent of the filtered power was fed back through the feedback ring to form an injection seeding in FP1. Two isolators were used in the feedback ring to ensure the feedback direction. Once a stable injection seeding in FP1 was established, the injection-seeded cw output of FP1 was filtered, and 90% of the selected wavelength power was amplified by an EDFA and then injected into the gain-switched FP laser diodes FP2 (with central wavelength of ~ 1537 nm, mode spacing of ~ 1.10 nm, and threshold current of ~ 14 mA) through a circulator. As a result, single-wavelength optical short pulses were generated. The gain-switched FP2 was driven by an rf electrical sinusoidal signal with power of ~ 10 dBm together with a dc-biased current of 14 mA via a bias tee circuit. The repetition frequency was set as 1.8 GHz, which was kept constant during the system operation. Two polarization con-

trollers (PCs) were used to adjust the polarization state of the feedback and external injection light, respectively.

For comparing our system performance, the experimental setup without the feedback ring in Fig. 2(b),⁸ in which the output from the dc-biased FP1 was sent directly to the tunable filter and then injected to the gain-switched FP2.

4. RESULTS AND DISCUSSION

Figures 3(a) and 3(b) demonstrate the output spectra of a dc-biased FP1 and a gain-switched FP2, with peak wavelength situated at 1548.7 and 1542 nm, respectively.

Figure 4(a) shows the dc-biased FP1 output spectra at point A, after passing through the FP filter, as shown in Fig. 2(b). The wavelengths are located at 1539.8, 1548.9, and 1557.8 nm with average power of -36.7 , -17.0 , and -17.7 dBm, respectively, and the SMSRs of the cw output from the filter are 27.6, 35.7 and 33.6 dB. Figure 4(b) displays the corresponding output spectra of the injection-seeded single-wavelength optical pulses. The SMSRs obtained are 14.5, 34.9, and 29.0 dB. As can be observed in Figs. 4(b)(ii) and 4(b)(iii), the side mode is not sufficiently suppressed, which is due to the large side mode existing in the injection light.

When a feedback ring is introduced into the system as shown in Fig. 2(a), the output spectra at point A and that from the external injection-seeding system output are shown in Figs. 5(a) and 5(b). The wavelengths are located

at 1539.8, 1548.9, and 1557.8 nm, the same as those in Fig. 4. In Fig. 5(a), the average power for the dc-biased FP1 output at point A is -21.1 , -11.9 , and -12.9 dBm, respectively; these levels are increased by approximately 15.1, 5.0, and 4.8 dB, respectively, compared with those in Fig. 4(a). It can also be observed that the lower the intensity, the higher the increase of power, which essentially flattens the injection-seeding power at different wavelengths, and, as a result, a wider wavelength tuning range can be obtained. It can also be seen that the SMSRs of cw output obtained at point A, after passing through the feedback ring, are largely increased by 15.3, 18.8, and 23.7 dB, when compared with those in Fig. 4(a), which can improve the SMSR of external injection-seeded optical short pulses. In Fig. 5(b), the SMSRs obtained are 33.4, 39.7, and 43.1 dB and are nearly 19.0, 5.2, and 14.0 dB larger than those obtained in Fig. 4(b), respectively.

One can realize continuous wavelength tuning by slightly tuning the temperature controller of FP1 to shift the position of the output spectrum and adjusting the tunable FP filter. The gain of the EDFA also needs to be increased by 7–8 dB in the case. Figure 6 shows the output spectra for the wavelengths located between the two adjacent modes of FP2, at 1539.7, 1548.4, and 1557.6 nm, respectively, with SMSRs of 35.3, 43.6, and 43.7 dB.

Figure 7 shows the waveforms of output pulse trains with wavelengths situated at 1548.9 and 1548.4 nm, corresponding to the output spectra at the laser mode and between the two adjacent modes as shown in Figs. 5(b)(i) and 6(ii); the full width at half-maximum (FWHM) values

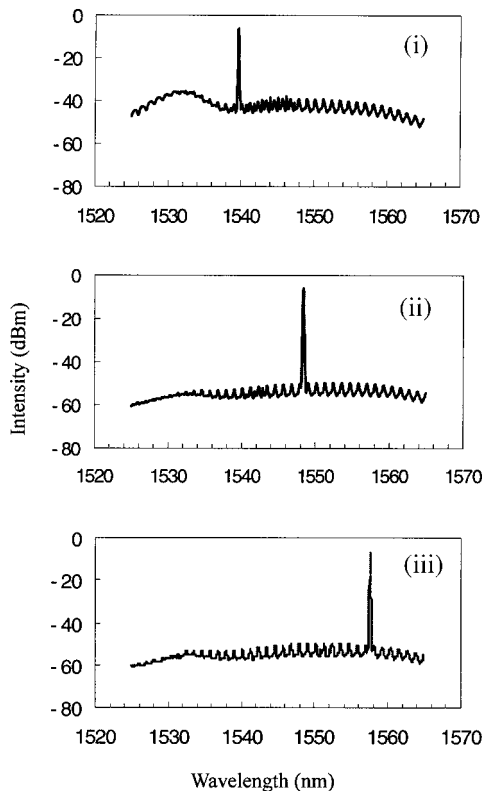

Fig. 6. Output spectra of injection-seeded optical single-wavelength pulses at the wavelengths located between the two laser modes, with a feedback to FP1 at wavelengths of (i) 1539.7, (ii) 1548.4, and (iii) 1557.6 nm.

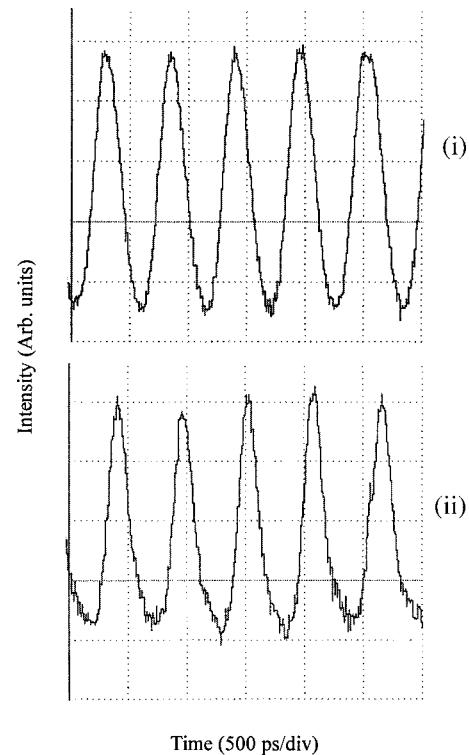

Fig. 7. Waveforms of output pulse trains at wavelengths of (i) 1548.9 and (ii) 1548.4 nm.

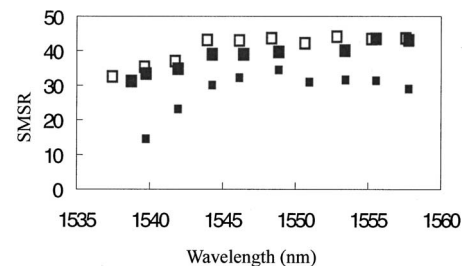

Fig. 8. SMSRs of the injection-seeded optical short pulse at different wavelengths.

of the pulses are about 230 and 170 ps respectively, corresponding to the time–bandwidth product of 3.8 and 2.8, respectively. The output pulses usually exhibit frequency chirp due to inherent carrier density reduction during pulse emission, which leads to a relatively large pulse width. However, such a frequency chirp can be compensated, and the pulse be compressed by use of dispersive fibers and chirped fiber Bragg gratings. The time jitter of the output pulses is around 1 ps, as a result of using a feedback fiber loop.¹² The amplitude noise for the output pulse on the mode is low, whereas increases for the output pulse between two adjacent modes are about 5%.

SMSRs of the injection-seeded single-mode optical short pulses obtained at different wavelengths are shown in Fig. 8. The wavelength tuning range achieved is 20.4 nm, between 1537.5 and 1557.8 nm, for the SMSR higher than 31 dB. For the SMSR higher than 40 dB, the wavelength tuning range is 13.8 nm, between 1644.0 and 1557.8 nm. It can be observed from Fig. 8 that the SMSRs for the injection-seeded wavelengths between the two ad-

adjacent modes of FP2 are slightly higher than that at the laser modes of FP2, which is because a higher EDFA gain is used at these wavelengths. For the injection seeding without feedback to FP1, the SMSR obtained is decreased by 5 to 19 dB when compared with that with feedback, at the laser modes of FP2. The wavelength tuning range is also reduced to ~ 13.5 nm, between 1544.3 and 1557.8 nm, corresponding to the SMSR higher than 30 dB. The results indicate that the external injection-seeding scheme with feedback to FP1 can effectively increase and flatten the SMSR and extend the wavelength tuning range.

5. CONCLUSION

An external injection-seeding scheme with feedback to the master FP laser diode is developed to improve the SMSR and extend the wavelength tuning range of the injection-seeded optical short pulses. Wavelength-tunable optical short pulses with a SMSR higher than 31 dB over a wavelength tuning range of 20.4 nm have been obtained. When the SMSR is higher than 40 dB, the corresponding wavelength tuning range obtained is 13.8 nm. The system is simple and can be operated at arbitrary repetition frequency.

ACKNOWLEDGMENT

The research was supported by the Hong Kong Special Administrative Region government through a Competitive Earmarked Research Grant PolyU5207/03E. Corresponding author X. Fang can be reached by e-mail at xhfang402@hotmail.com.

REFERENCES

1. M. Schell, D. Huhse, and D. Bimberg, "Generation of 2.5-ps light pulses with 15-nm wavelength tunability at 1.3 μm by a self-seeded gain-switched semiconductor laser," *IEEE Photon. Technol. Lett.* **5**, 1267–1269 (1993).
2. Y. Zhao and C. Shu, "Single-mode operation characteristics of a self-injection seeded Fabry–Perot laser diode with distributed feedback from a fiber grating," *IEEE Photon. Technol. Lett.* **9**, 1436–1438 (1997).
3. X. Fang and D. N. Wang, "Mutual pulse injection seeding by the use of two Fabry–Perot laser diodes to produce wavelength-tunable optical short pulses," *IEEE Photon. Technol. Lett.* **15**, 855–857 (2003).
4. Y. Matsui, S. Kutsuzawa, S. Arahira, and Y. Ogawa, "Generation of wavelength tunable gain-switched pulses from FP MQW lasers with external injection seeding," *IEEE Photon. Technol. Lett.* **9**, 1087–1089 (1997).
5. L. P. Barry, P. Anandarajah, and A. Kaszubowska, "Optical pulse generation at frequencies up to 20 GHz using external-injection seeding of a gain-switched commercial Fabry–Perot laser," *IEEE Photon. Technol. Lett.* **13**, 1014–1016 (2001).
6. A. M. Clarke, P. M. Anandarajah, and L. P. Barry, "Generation of widely tunable picosecond pulses with large SMSR by externally injecting a gain-switched dual laser source," *IEEE Photon. Technol. Lett.* **16**, 2344–2346 (2004).
7. M. Zhang, D. N. Wang, H. Li, W. Jin, and M. S. Demokan, "Tunable dual-wavelength picosecond pulse generation by the use of two Fabry–Perot laser diodes in an external injection seeding scheme," *IEEE Photon. Technol. Lett.* **14**, 92–94 (2002).
8. D. N. Wang and X. Fang, "Generation of electrically wavelength-tunable optical short pulses using a Fabry–Perot laser diode in an external-injection seeding scheme with improved sidemode suppression ratio," *IEEE Photon. Technol. Lett.* **15**, 123–125 (2003).
9. D. N. Wang, X. Fang, and W. Jin, "Generation of continuous wavelength-tunable optical short pulses with two Fabry–Pérot laser diodes in an external injection-seeding scheme," *J. Opt. Soc. Am. B* **22**, 917–921 (2005).
10. K. Petermann, *Laser Diode Modulation and Noise* (KTK Scientific, 1991).
11. J. Dellunde, M. C. Torrent, J. M. Sancho, and M. S. Miguel, "Frequency dynamics of gain-switched injection-locking semiconductor lasers," *IEEE J. Quantum Electron.* **33**, 1537–1540 (1997).
12. K. Nonaka and H. Mizuno, "Sub-picosecond time jitter suppression using an optical feedback mechanism for a laser diode short pulse generator," *Meas. Sci. Technol.* **15**, 1581–1585 (2004).