

Journal of Biomechanics
Submitting as a *Communication*
First Submission: June 27 2003

Ultrasonic Measurement of Depth-Dependent Transient Behaviors of Articular Cartilage under Compression

Y.P. Zheng*, H.J. Niu, F.T. Arthur Mak, and Y.P. Huang

Jockey Club Rehabilitation Engineering Center, The Hong Kong Polytechnic University

Keywords: Articular Cartilage, Biomechanics, Ultrasound, Elastography,

*** Corresponding Author:** Dr. Yongping Zheng
Rehabilitation Engineering Center,
The Hong Kong Polytechnic University,
Kowloon, Hong Kong
Tel: 852 27667664
Fax: 852 23624365
Email: htzheng@polyu.edu.hk

Word Count: 1780

ABSTRACT

We previously reported an ultrasound method for measuring the depth-dependent equilibrium mechanical properties of articular cartilage using quasi-static compression. The objective of this communication was to introduce our recent development for nondestructively measuring the transient depth-dependent strains of full-thickness articular cartilage specimens from bovine patellae. A 50 MHz focused ultrasound transducer was used to collect ultrasound echoes from articular cartilage specimens (n=8) and sponge phantoms with open pores (n=10) during tests of compression and subsequent stress-relaxation. The transient displacements of the tissues at different depths along the compression direction were calculated from the ultrasound echoes using a cross-correlation tracking technique. An LVDT sensor and a load cell were used to measure the overall deformation of the tissue and the applied force, respectively. Results showed that the tissues inside the cartilage layer continued to move during the stress-relaxation phase after the compression was completed. In the equilibrium state, the displacements of the cartilage tissues at depths of 1/4, 1/2, and 3/4 of the full-thickness reduced by $51\pm 22\%$, $54\pm 17\%$, and $50\pm 17\%$ in comparison with its peak value. However, the similar phenomenon had not been observed in the sponge phantom. Our preliminary demonstrated that this ultrasound method may provide a potential tool for the nondestructive measurement of the transient depth-dependent processes involved in biological and bioengineered soft tissues as well as soft biomaterials under dynamic loading.

1. Introduction

Articular cartilage is an important biological weight-bearing tissue covering the ends of articulating bones within synovial joints. Its function very much depends on the unique multi-layered structure and depth-dependent material properties (Mankin et al. 1994). Recently, optical microscopic methods associated with compression tests have been used to study the equilibrium inhomogeneous properties of articular cartilage (Guilak et al. 1995, Schinagl et al. 1996, Wang et al. 2002). It has been demonstrated using these methods that the tissues at deeper layers are significantly stiffer than those at the superficial layer in articular cartilage. Using these optical methods, cartilage specimens need to be cut and well prepared for the microscopic markers at different depths of articular cartilage, and only the cut-surface can be imaged to derive the tissue deformation induced by a compression. Thus, it may be difficult to use these methods to obtain the transient behaviors of articular cartilage in its natural intact state without affecting the integrity of the tissue.

Ultrasound methods have also been used to measure the articular cartilage properties of entire layer as well as individual layers together with indentation and unconfined compression tests (Zheng and Mak 1996, Zheng et al. 2001, 2002, Suh et al. 2001, Laasanen et al. 2002, Fortin et al. 2003). The basic principle of these methods is to compress the cartilage tissues and simultaneously collect ultrasound echoes from the tissues. The deformations of the tissues are estimated from the movement of the ultrasound echoes. If the echoes from the AC boundary surfaces are collected, the full-thickness tissue deformation can be measured (Zheng and Mak 1996, Suh et al. 2001,

Laasanen et al. 2002). The depth-dependent material properties can be obtained by analyzing the echoes collected from the cartilage tissues along the same direction of the applied compression (Zheng et al. 2001, 2002). Cohn et al. (1997) reported an ultrasonic system to measure strain distributions of tissue specimens by squeezing them out of a slit (2.6 mm) in the compressor. The ultrasound beam was arranged to propagate through the slit and used to monitor how the tissues were squeezed out. Use of the slit introduced complicated boundary conditions on the specimen. In a recent communication, Fortin et al. (2003) introduced a method to map the transient lateral displacements of articular cartilage tissue by compressing the specimen in one direction and collecting ultrasound echoes in an orthogonal direction. Using this method, they measured the time-dependent lateral-to-axial ratio of articular cartilage. The objective of this communication was to introduce our recent development for mapping the transient interstitial displacements of full-thickness articular cartilage specimens in an in-situ configuration. Sponge specimens were also tested and their results were compared with those of the cartilage specimens.

2. Methods

Figure 1 shows the ultrasound-compression testing configuration and data collection system used in this study. The ultrasound-compression device was installed in a container filled with 0.15 M saline solution. A 50 MHz focused ultrasound beam (Panametrics, Waltham, MA, USA) was transmitted through a very thin layer of subchondral bone into the specimen via a small hole (approximately 0.5 mm in diameter) located at the center of the specimen platform. The focal zone of the ultrasound beam has a -6 dB diameter of approximately 0.1 mm and a -6 dB length of approximately 1 mm.

An impermeable compressor made from stainless steel (Zheng et al. 2002) was attached to the load cell and used to compress the specimen from the top. The applied load was collected using a 25 N load cell (Model ELFS-T3E-5L from Entran, NJ, USA). The ultrasound reflection signals were digitized in 500 MHz (Model CompuScope 8500PCI from Gage, Canada). The ultrasound echo trains and the load signals were collected in a frame rate of approximately 1 Hz. In addition, an LVDT sensor (Model DFg5.0, Solartron, UK) was used to measure the displacement of the compressor.

Full-thickness cylindrical cartilage specimens (n=8, with the mean diameter of 6.32 ± 0.08 mm, and the mean thickness of 1.54 ± 0.17 mm) with a thin layer of bone (approximately 0.1 mm in thickness) were prepared from 8 different fresh mature bovine patellae (Zheng et al. 2001, 2002). This thin layer of bone was oriented towards the hole in the specimen platform during the tests to prevent the cartilage tissue from being squeezed into the hole and to maintain an in-situ situation of the cartilage specimen. The small hole was used to provide a passage for the ultrasound beam propagating into the articular cartilage specimen without generating large reflection signals from the surface of the specimen platform. Otherwise, the large reflection would overlap the weak scattering signals from the articular cartilage tissues. For comparison purposes, sponge specimens with open pores (n=10, with the mean diameter of $?? \pm ??$ mm, and the mean thickness of $?? \pm ??$ mm) were also tested in this study. The saline solution can move freely into or out of the sponge matrix under the compression. For the tests on the sponge specimens, a piece of adhesive tape with a thickness of approximately 0.1 mm was adhered on the surface of the specimen platform to cover the hole so as to prevent the sponge tissue from being squeezed into it (Zheng et al. 2003).

During a test, the compressor was first gradually moved against the surface of the cartilage specimen to generate a contact and perform a 0.05 mm pre-compression. In this study, for every step, the criterion for a complete relaxation was a relaxation rate 100 Pa/min (Korhonen et al. 2002). After pre-compression and equilibrating for approximately 1800 s, two steps of ramp compression of approximately 0.05 mm (with a compression rate of approximately 0.1 mm/min) were applied (Figure 4a). Ultrasound echo trains were continuously collected during the compression and the subsequent stress-relaxation phases (Figures 4c). In order to compare with, a same experiment has been done using sponge specimen. After a 0.1mm pre-compression and equilibrating for approximately 400 s, two steps of ramp compression of approximately 0.1 mm, and the relaxation time is shorten to about 400s (Figure 5).

The transient displacements of the articular cartilage tissues and the sponge specimen at different depths were studied using M-mode representation of the ultrasound signals respectively. This means that the echoes at different measurement times were drawn line by line to form an image, with the grey level indicating the amplitude of the ultrasound signals (Figure 4c and Figure 5c). The horizontal traces in Figure 4c and Figure 5c indicate the transient movements of the ultrasound echoes which correspond to the displacements of the tissues at different depths. In addition, the transient displacements of the articular cartilage tissues and the sponge specimen tissues at selected depths during the compression and the stress-relaxation was extracted using a cross-correlation echo tracking method (Ophir et al. 1999, Zheng et al. 2002). The time

resolution for the displacement measurement was 0.4 ns using the 500 MHz A/D conversion and 5 times of linear data interpolation (Zheng et al. 2002). It corresponded to a displacement resolution of 0.34 μm for an average ultrasound 1666 m/s in AC (Joiner et al. 2001). The displacements of tissues at two adjunct depths were used to calculate the strain of that sub-layer of AC.

3. Results

As shown in Figure 4c and Figure 5c, the movements of the articular cartilage tissues and the sponge tissues at different depths during the compression and subsequent stress-relaxation phases have been successfully captured by the ultrasound measurement system respectively. Each trace at a certain depth in Figure 4c and Figure 5c represented the transient displacement of the tissue at that depth. It was observed that the tissues inside the articular cartilage layer continued to move during the relaxation phases (Figure 4c). The patterns of the tissue movements were quite consistent for the two steps of the ramp-compression and stress-relaxation. These transient phenomena could be observed more clearly when the displacements of the tissues at different depths were extracted using the cross-correlation tracking approach (Figure 6a). However, this kind of phenomenon does not appear inside the sponge specimen (Figure 5a).

In the calculation, the displacement of the articular cartilage-bone interface indicated by the triangle mark on the bottom of Figures Figures 4b and 4c was subtracted from other displacements. As shown in Figure 4c, this displacement was relatively much

smaller in comparison with those of the tissues at the middle layer of the articular cartilage. This might be caused by the slight bending of the thin bone layer which contacted to the small hole in the specimen platform as shown in Figure 1 and the different boundary condition between the middle zone and the deep zone, there is limited lateral expansion for tissue under compression in deep zone .

4. Discussion

In this study, we have successfully demonstrated that the ultrasound technique together with a compression test can be used to investigate the transient compressive mechanical properties of the articular cartilage tissues at different depths. It was observed from the results that the articular cartilage tissues kept moving during the relaxation phase after the completion of the ramp-compression. The results were consistent for the two steps of the compression and relaxation. However, this kind of phenomenon of the tissue moving during relaxation phase does not appear inside the sponge specimen. We can think the sponge an absolute viscoelastic material. This means the water redistribution is the main factor to introduce this phenomenon. This result also showed that the transient phenomenon of the articular cartilage agreed with the theoretical prediction using biphasic models of articular cartilage (Mow et al. 1980). As the water redistributed gradually within tissue matrix of articular cartilage during the stress-relaxation phase, the local strains continued to change at different depths of the tissue. Similar phenomena have been reported by Fortin et al. (2003) for the lateral movements of articular cartilage tissues under an axial compression.

The depth-dependence of the ultrasound speeds in articular cartilage has been previously observed (Agemura et al. 1990, Zheng et al. 2003). The variations of ultrasound speed in articular cartilage may affect the calculation of tissue thickness and displacements. Our recent results demonstrated that the ultrasound speed in the deep zone was approximately 10% larger than that in the superficial zone for the bovine patellar articular cartilage (Zheng et al. 2002). This issue should be taken into account in the future applications of this technique. In addition, the potential changes of the ultrasound speeds during the compression and stress-relaxation may be accounted for the transient displacements. We observed that the sound speed of the measured full-thickness articular cartilage increased about 11.502 ± 2.341 m/s before and after the stress-relaxation phases. This change caused a slightly shift of the trace of the ultrasound echo reflected from the AC/compressor interface during the stress-relaxation phases as shown in Figure 4c. This effect should be compensated for the tissue displacements in the future data analysis.

The pattern of the ultrasound signals scattered from a portion of articular cartilage tissues might change when a large compression was applied. This de-correlation phenomenon (Ophir et al. 1999) of the scattering signal might affect the accuracy of the cross-correlation tracking, particularly during the compression phase. In this study, the tissue was compressed by approximately 3.4% during each ramp-compression. We used a frame rate of 1 Hz, which is high relative to the compression rate, to collect ultrasound signals so as to track the echoes frame by frame and to avoid a large deformation between frames. In addition, the signal-to-noise ratio of the ultrasound echoes is another critical issue for a successful measurement using this ultrasound technique. As shown in Figure

4c, the displacement is difficult to trace for the superficial region (at the depth between surface and depth in 0.608 mm) of the articular cartilage tissues (the upper region in the figure), as ultrasound echoes are too weak at this region. The preparation of the thin bone layer is an important step. A too thin layer of bone cannot successfully prevent the specimen being squeezed into the hole in the specimen platform, while a too thick layer of bone may cause a large attenuation to the ultrasound echoes. Efforts are being made to further improve the signal-to-noise ratio of the echoes.

Overcoming above potential limitations,, this ultrasound system has potentials for the investigation of the transient deformations of articular cartilage tissues at different depths under dynamic loading. The system can also be used to study the transient behaviors of degenerated articular cartilage. We also expected that this ultrasound approach can be used for the assessment of other biological soft tissues, bio-engineered tissues, and biomaterials.

Acknowledgement

This work is partially support by The Hong Kong Research Grant Council (PolyU21/96M, PolyU5199/02E) and The Hong Kong Polytechnic University (G-T468).

References

Agemura, D.H., O'Brien, W.D., Olerud, J.E., Chun, L.E., Eyre, D.E., 1990. Ultrasonic propagation properties of articular cartilage at 100 MHz. *Journal of Acoustic Society of America* 87, 1786-1791.

- Cohn, N.A., Emelianov, S.Y., Lubinski, M.A., O'Donnell, M., 1997. An elasticity microscope. Part I: Methods. *IEEE Transactions on Ultrasonics, Ferroelectrics, and Frequency Control* 44, 1304-1319.
- Fortin, M., Buschmann, M.D., Bertrand, M.J., Foster, F.S., Ophir, J., 2003. Dynamic measurement of internal solid displacement in articular cartilage using ultrasound backscatter. *Journal of Biomechanics* 36, 443-447.
- Guilak, F., Ratcliffe, A., Mow, V.C., 1995. Chondrocyte deformation and local tissue strain in articular cartilage: a confocal microscopy study. *Journal of Orthopaedic Research* 13, 410-421.
- Joiner, G.A., Bogoch, E.R., Pritzker, K.P., Buschmann, M.D., Chevrier, A., Foster, F.S., 2001. High frequency acoustic parameters of human and bovine articular cartilage following experimentally-induced matrix degradation. *Ultrasonic Imaging* 23, 106-116.
- Korhonen, R.K., Laasanen, M.S., Toyras, J., Rieppo, J., Hirvonena, J., Helminenb, H.J., Jurvelina, J.S., 2002. Comparison of the equilibrium response of articular cartilage in unconfined compression, confined compression and indentation. *Journal of Biomechanics* 35, 903-909.
- Laasanen, M.S., Toyras, J., Hirvonen, J., Saarakkala, S., Korhonen, R.K., Nieminen, M.T., Kiviranta, I., Jurvelin, J.S., 2002. Novel mechano-acoustic technique and instrument for diagnosis of cartilage degeneration. *Physiological Measurement* 23, 491-503.
- Mankin, H.J., Mow, V.C., Buckwalter, J.A., Iannotti, J.P., Ratcliffe, A., 1994. Form and function of articular cartilage. In: Simmon, S.R., ed. *Orthopaedic Basic Science*. American Academy of Orthopaedic Surgeons.
- Mow, V.C., Kuei, S.C., Lai, W.M., Armstrong, C.G., 1980. Biphasic creep and stress relaxation of articular cartilage in compression: theory and experiment. *Journal of Biomechanical Engineering* 102, 73-84.
- Ophir, J., Alam, S.K., Garra, B., Kallel, F., Konofagou, E., Krouskop, T., Varghese, T., 1999. Elastography: ultrasonic estimation and imaging of the elastic properties of

- tissues. Proceedings of the Institution of Mechanical Engineers. Part H, Journal of Engineering in Medicine, 213, 203-233.
- Schinagl, R.M., Ting, M.K., Price, J.H., Sah, R.L., 1996. Video microscopy to quantitate the inhomogeneous equilibrium strain within articular cartilage during confined compression. *Annals of Biomedical Engineering* 24, 500-512.
- Suh, J.K.F., Youn, I., Fu, F.H., 2001. An in situ calibration of an ultrasound transducer: a potential application for an ultrasonic indentation test of articular cartilage. *Journal of Biomechanics* 34, 1347-1353.
- Wang, C.C.B., Guo, X.E., Sun, D.N., Mow, V.C., Ateshian, G.A., Hung, C.T., 2002. The functional environment of chondrocytes within cartilage subjected to compressive loading: a theoretical and experimental approach. *Biorheology* 39, 11-25.
- Zheng, Y.P. and Mak, A.F.T., 1996. An ultrasound indentation system for biomechanical properties assessment of soft tissues in-vivo. *IEEE Transactions on Biomedical Engineering* 43, 912-918.
- Zheng, Y.P., Ding, C.X., Bai, J., Mak, A.F.T., Qin, L., 2001. Measurement of the layered compressive properties of trypsin treated articular cartilage: an ultrasound investigation. *Medical and Biological Engineering and Computing* 39, 534-541.
- Zheng, Y.P., Mak, A.F.T., Lau, K.P., Qin, L., 2002. An ultrasonic measurement for in vitro depth-dependent equilibrium strains of articular cartilage in compression. *Physics in Medicine and Biology* 47, 3165-3180.
- Zheng, Y.P., Patil, S.G., Wu, J.Y.. Depth-dependent ultrasound speed of articular cartilage of bovine patella in vitro. *Physiological Measurement*. Submitted in March 2003.

Figure Captions:

Figure 1. Diagram of the ultrasound-compression system. A: Load cell; B: Compressor; C: Specimen platform; D: AC specimen; E: Ultrasound transducer.

Figure 2. (a) A typical stress response during the two steps of ramp compression and subsequent stress-relaxation. (b) A typical set of ultrasound echoes collected from the AC tissues at different depths; (c) M-mode representation of the ultrasound signals as a function of the measurement time with the grey level indicating the signal amplitude as shown in (b). The signal amplitudes indicated by the two vertical dashed lines in (b) were normalized into 256 grey levels in (c). The solid and open triangle marks indicate the signals reflected from the compressor/AC interface and from the AC/bone interface, respectively. The horizontal traces in (c) indicate the transient movements of the ultrasound echoes which correspond to the displacements of the tissues at different depths.

Figure 3. The transient displacements of tissues at different depths. They are derived from the ultrasound signals shown in Figure 2 using a continuous cross-correlation tracking approach. The legends indicate the depths of the tissues where the displacements were extracted. For the transient displacement of the tissue at the depth of 0.36 mm, the cross-correlation tracking for the echoes could not be achieved for the second step of compression due to the low signal-to-noise ratio.

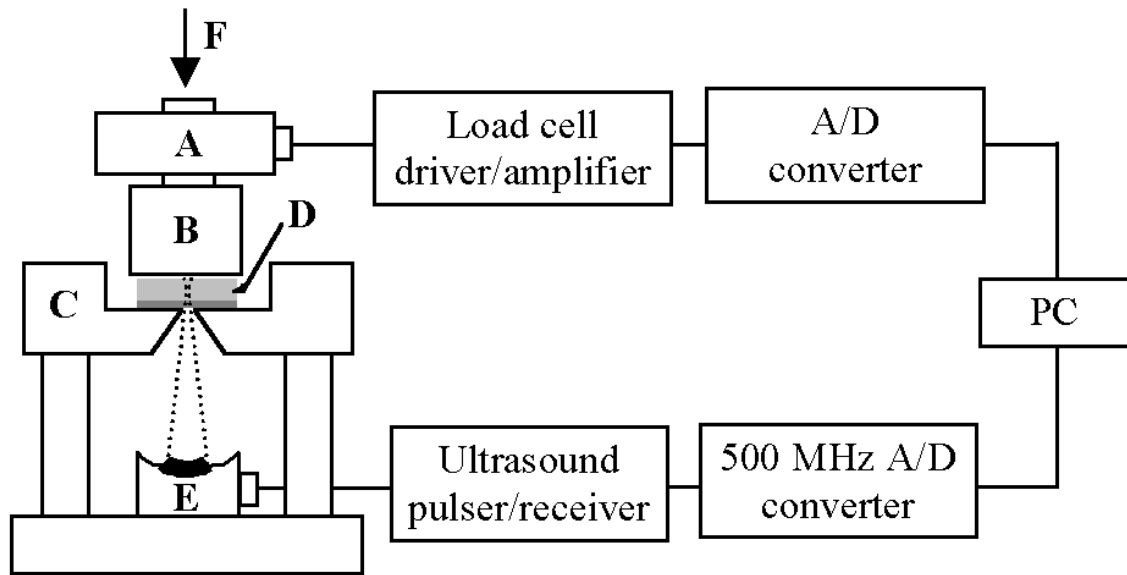

Figure 1. (Zheng et al. 2003)

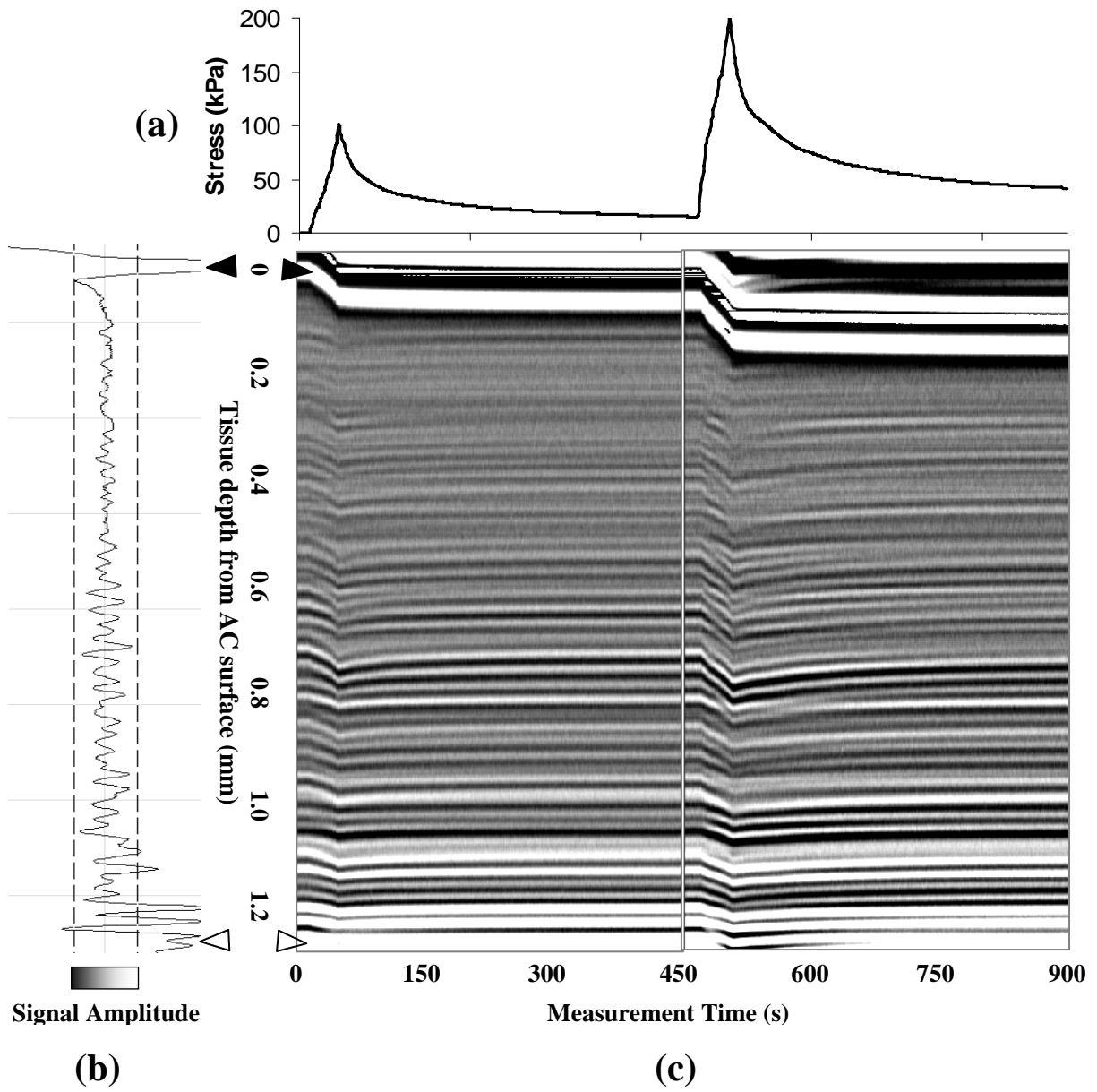

Figure 2.

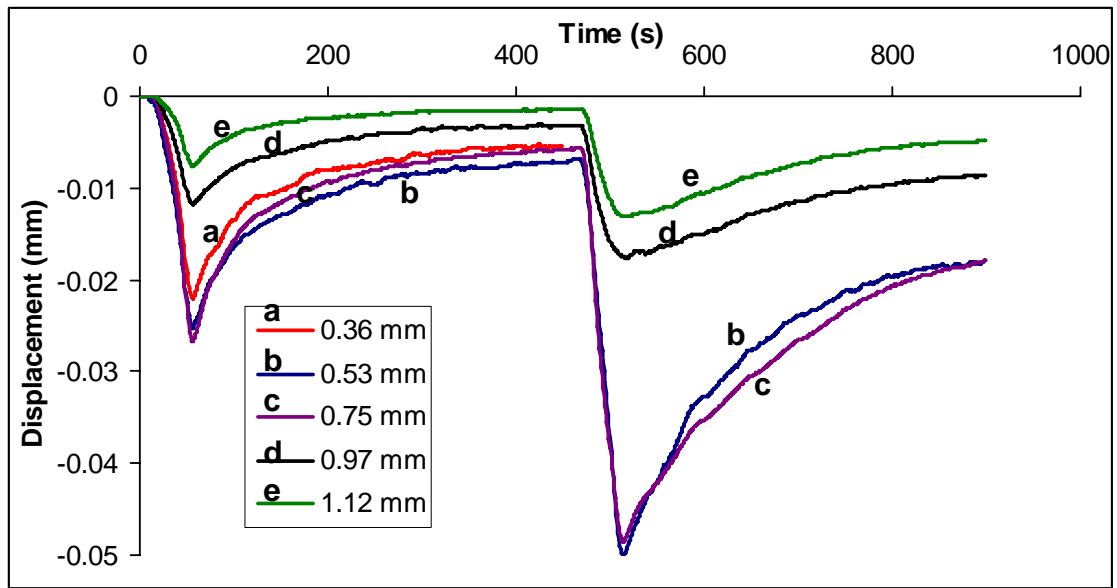

Figure 3.

Figure Captions:

Figure 1. Diagram of the ultrasound-compression system. A: Load cell; B: Impermeable compressor; C: Specimen platform with a hole (approximately 0.5 mm in diameter) in the center; D: Specimen; E: Focused ultrasound transducer; F: Applied force. A thin bone layer for the articular cartilage specimen and a thin adhesive tape for the sponge specimen were used to prevent the tissues squeezing into the hole,

Figure 2. (a) A typical stress response of the cartilage during the two steps of ramp compression and subsequent stress-relaxation. (b) A typical set of ultrasound echoes collected from the articular cartilage tissues at different depths; (c) M-mode representation of the ultrasound signals as a function of the measurement time with the grey level indicating the signal amplitude as shown in (b). The signal amplitudes indicated by the two vertical dashed lines in (b) were normalized into 256 grey levels in (c). The solid and open triangle marks indicate the signals reflected from the compressor/articular cartilage interface and from the articular cartilage/bone interface, respectively. The horizontal traces in (c) indicate the transient movements of the ultrasound echoes which correspond to the displacements of the tissues at different depths.

Figure 3. (a) A typical stress response of the sponge specimen during the two steps of ramp compression and subsequent stress-relaxation. (b) A typical set of ultrasound echoes collected from the sponge tissues at different depths; (c) M-mode representation of the ultrasound signals as a function of the measurement time with the grey level indicating the signal amplitude as shown in (b). The signal amplitudes indicated by the two vertical dashed lines in (b) were normalized into 256 grey levels in (c). The solid and open triangle marks indicate the signals reflected from the compressor/sponge interface and from the sponge/bottom interface, respectively. The horizontal traces in (c) indicate the transient movements of the ultrasound echoes which correspond to the displacements of the sponge tissues at different depths.

Figure 4. The transient displacements of the samples at different depths. (a) cartilage

specimen. (b) sponge specimen. They are derived from the ultrasound signals shown in Figure 4 and 5, respectively using a continuous cross-correlation tracking approach. The legends indicate the depths of the tissues where the displacements were extracted. For the transient displacement of the cartilage at the depth between surface and depth in 0.608 mm could not be achieved due to the low signal-to-noise ratio.

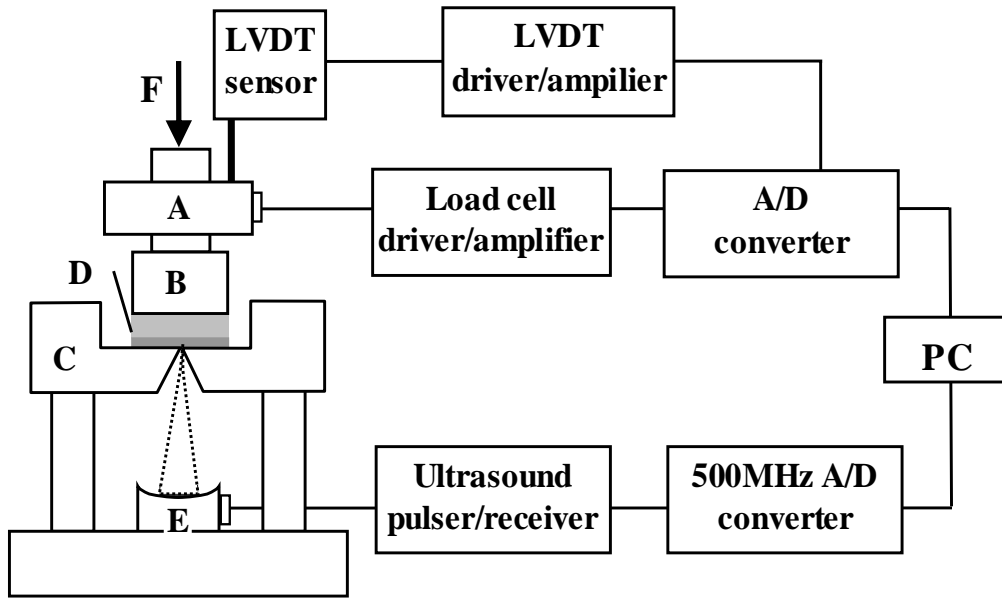

Figure 1.

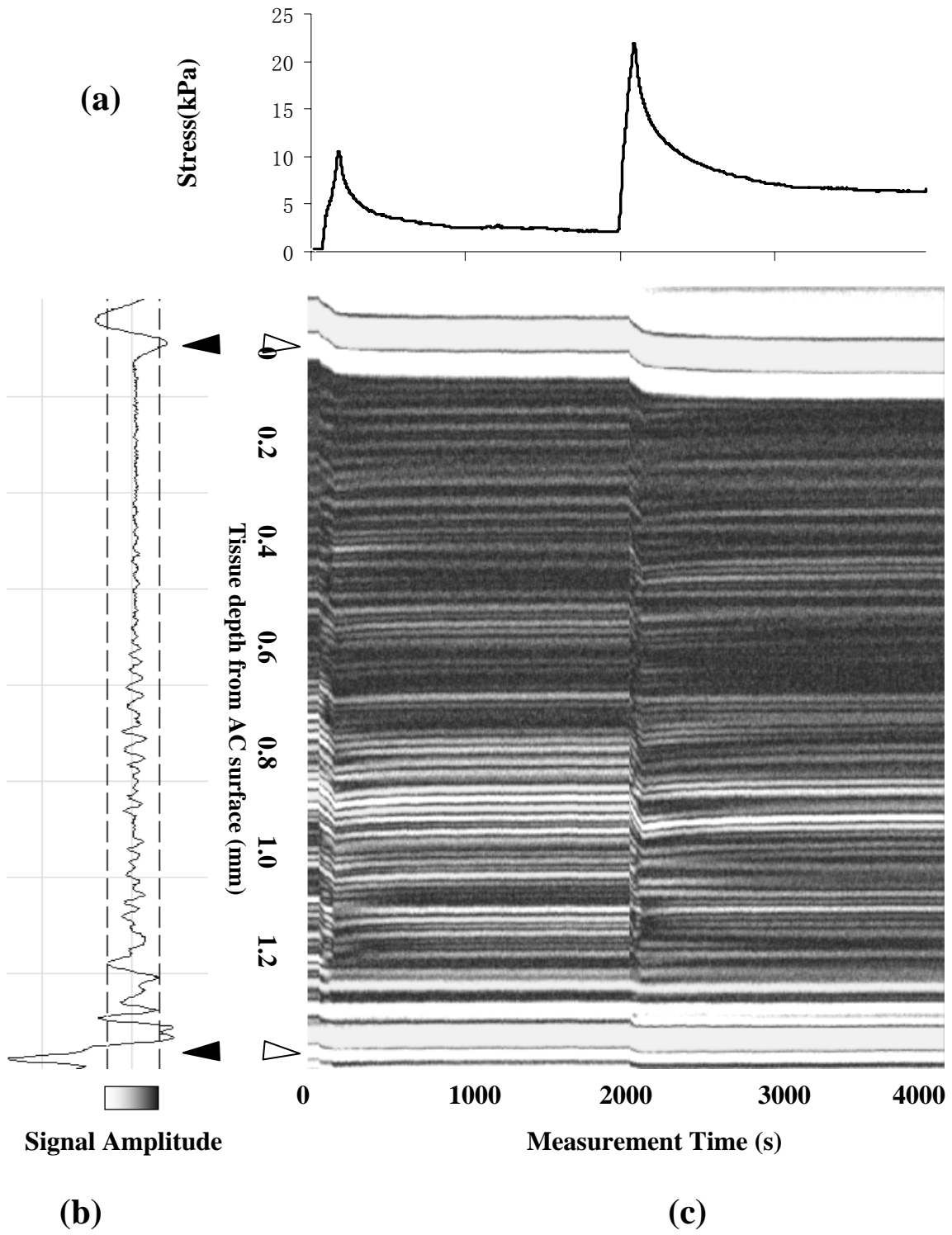

Figure 2.

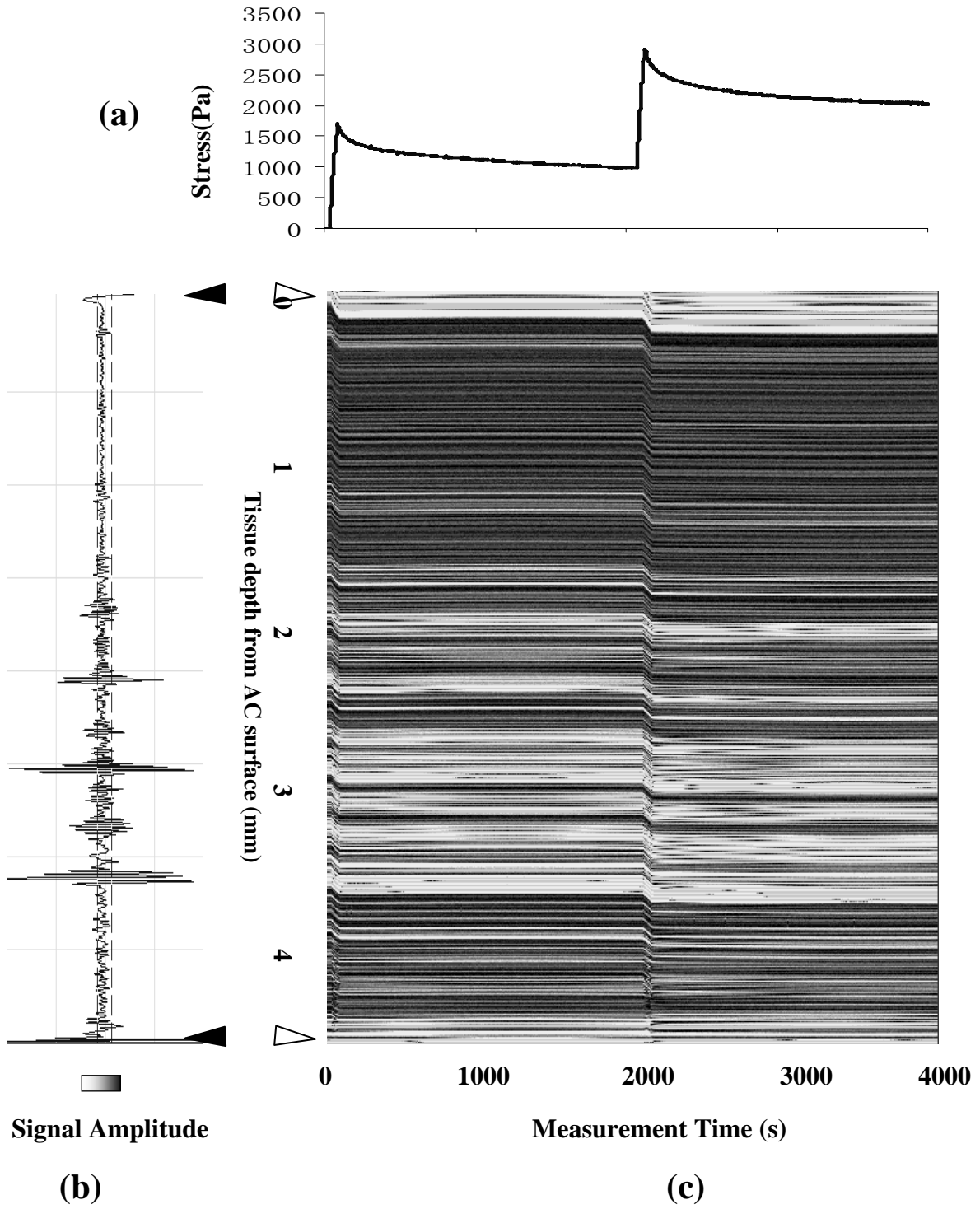
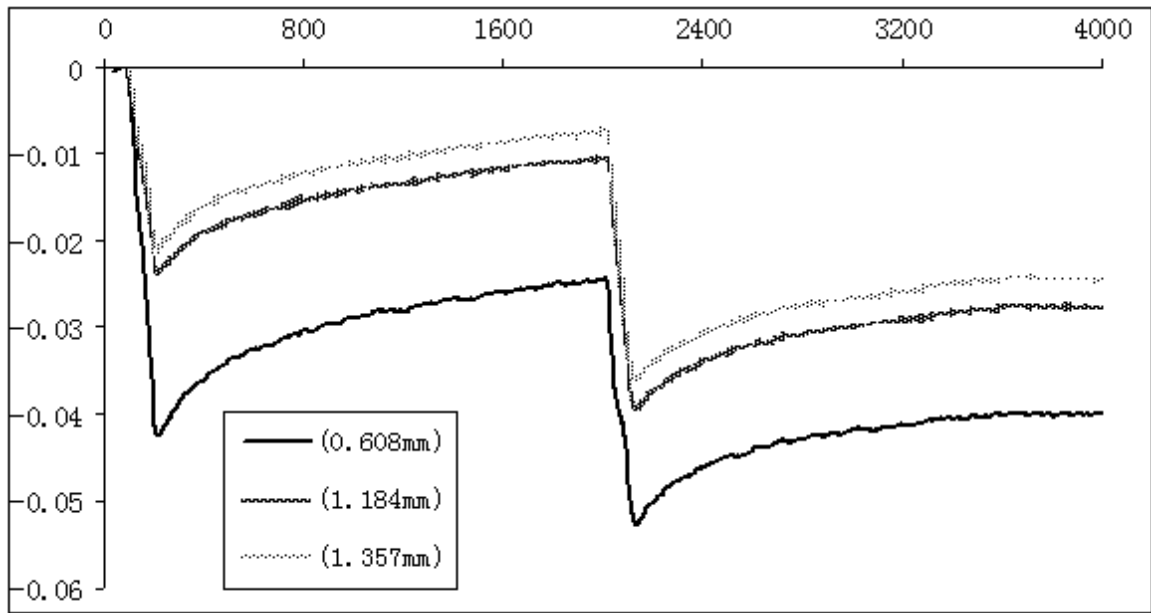
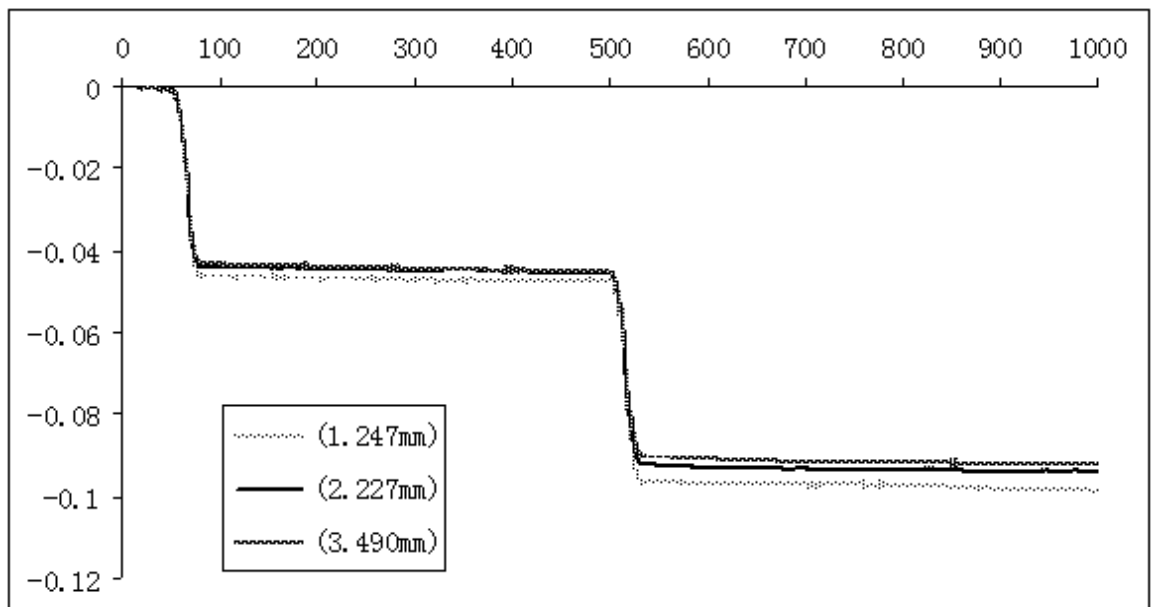

Figure 3.

(a)
Stress(Pa)



(a)



(b)

Figure 4.

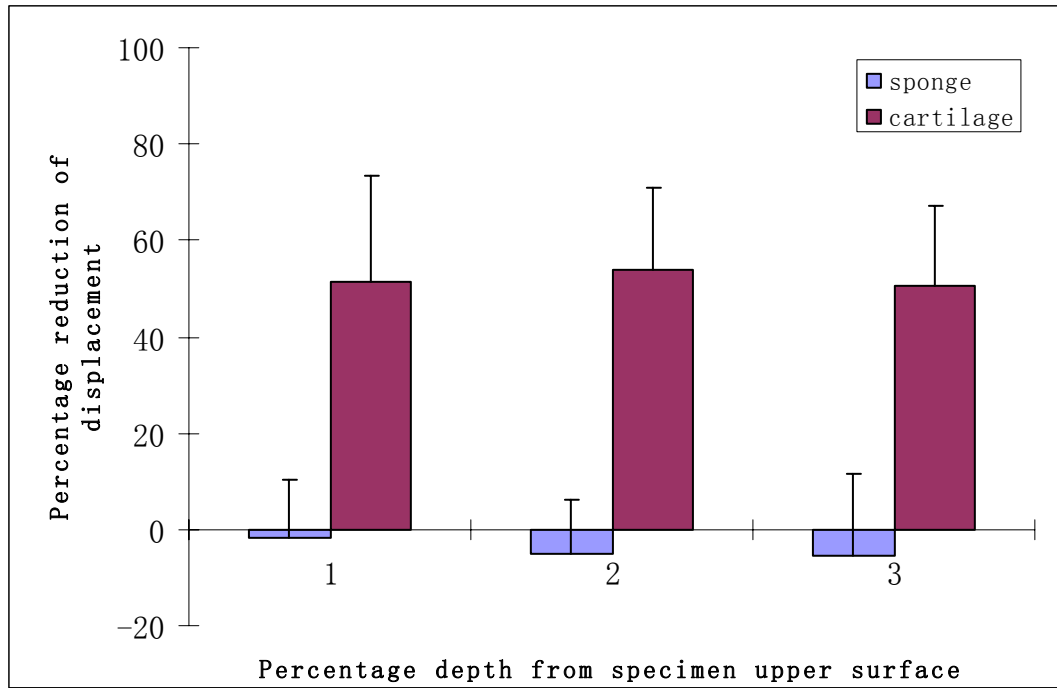

Figure 5.