

Low Cost DIY Solar Energy Hot Water System

CM Cheung, SK Lee, CP Leung, NC Cheung
 Department of Electrical Engineering
 The Hong Kong Polytechnic University
 Hunghom, Kowloon Hong Kong
 E-mail: norbert.cheung@polyu.edu.hk

Abstract – This paper describes a low cost hot water system for domestic use. The system is very simple, low in cost, and can be made without any sophisticated equipment and manufacturing tools.

INTRODUCTION

This paper describes a domestic solar energy hot water system that is suitable for domestic use. In domestic homes, electricity for hot water normally use up a large proportion of the electricity energy bill. This portion of expenses will increase when the cost of fuel gets more and more expensive. Solar energy is plentiful and abundant, therefore it is an attractive proposition to tap this energy to heat up water for the homes. However, using photovoltaic cells to generate electricity for heating are very expensive. There are some commercial direct heating solar hot water systems in the market; however, they are still too expensive for the average home. In this paper, we will introduce a DIY solar energy hot water system that is both low cost and easy to make. The system can be divided into three, namely the heat collection unit, the temperature sensing and control, and software design.

THE TEMPERATURE SENSING UNIT

The temperature sensing unit consists of copper tubes bended in a rectangular spiral form. To prevent heat loss, the tubes are enclosed inside a sealed box. The lining of the box is coated with black paint, and a thick glass is put on top. See Fig. 1 for the details.

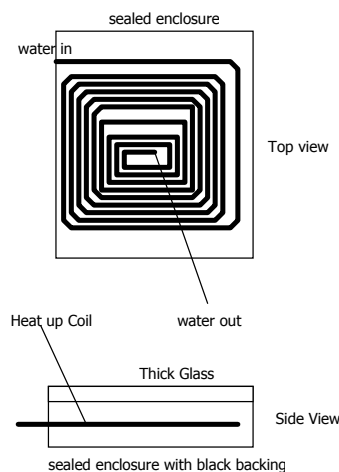

Fig. 1 The Heat collection unit

THE CONTROL UNIT

The control unit consists of a low cost embedded processor. The processor collects the temperature information on the inlet and outlet of the heat collection unit, and controls the flow of water into the heat collection unit. Fig. 2 shows the circuit diagram of the control unit. The heart of the control unit is a low cost 8051 processor. Only very few external components are needed to construct the whole control unit.

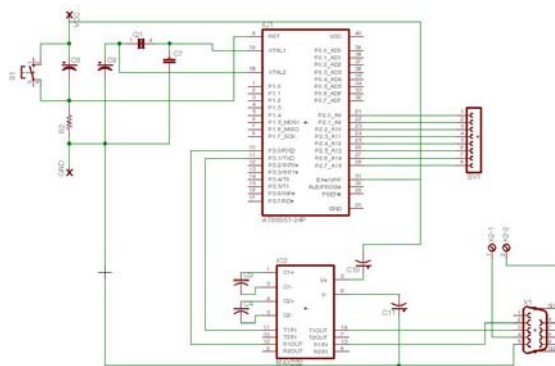

Fig. 2 The embedded control unit

Fig. 3 shows the circuit diagram of the LCD display unit. The unit displays the incoming and outgoing temperature of the DIY hot water system. Fig. 4 shows the temperature sensing circuit. Two semiconductor sensors are used to measure the temperature of the incoming and outgoing water. An 8 bit analogue to digital converter is used to convert the analogue temperature information back to digital form.

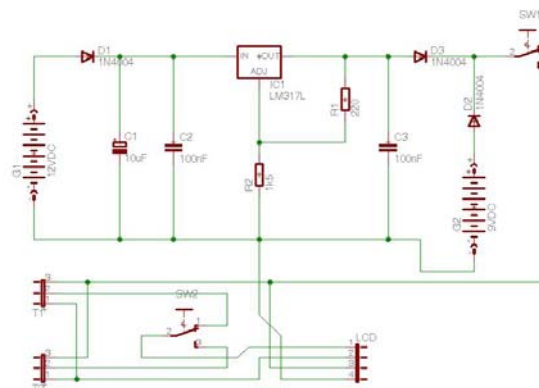

Fig. 3 The LCD display unit

CONCLUSION

This paper describes the design, construction, and testing of a very simple solar energy domestic hot water system. The system is low cost, and can be easily fabricated at home as a DIY project. The result measured on a sunny day is very encouraging: for a solar collection area of 1 square foot, it can heat up $\frac{1}{2}L$ of water from 40°C to 70°C in 15 minutes, or from 23°C to 70°C in 23 minutes. This simple project can promote the use of solar energy in domestic homes.

REFERENCES

- [1] Trimby Paul, "Solar water heating: a D-I-Y guide", Machynlleth (Wales), Centre for Alternative Technology Publications, 1995
 - [2] Zhao JC, "Practical Solar Hot Water System," Shanghai Technical Press 1983 (Chinese).
 - [3] HL Li, SY Wang, SC Chen, "8051/52 Single Chip Computer User's Guide," ChiShing Digital Press (Chinese)
 - [4] www.itdg.org/docs/technical_information_service/solar_water_heating.pdf
-