

# Alternative Energy Resource from Electric Transportation

Sutanto, D

Department of Electrical Engineering  
The Hong Kong Polytechnic University  
Hong Kong

E-mail: [eesutant@polyu.edu.hk](mailto:eesutant@polyu.edu.hk)

**Abstract** –Electric vehicles, whether powered by batteries, fuel cells, or petrol hybrids, have within them the energy source and power electronics capable of producing the AC electricity that powers our homes and offices. When bi-directional connections are added to allow this electricity to flow from cars to power lines and vice versa, this is referred to as "vehicle-to-grid" power, or V2G. The electric vehicles can then become mobile distributed generation resources, which can be valuable, particularly during peak hour. The Electric Power Research Institute predicts that power from electric-drive vehicles could reduce the global requirement for central station generation capacity by up to 20 percent by the year 2050.

The paper describes a power electronics system that can be used to provide the bidirectional power transfer capability of the charger. The proposed bi-directional power converter can also provide reactive power and voltage support which theoretically does not make use of the energy of the energy storage in the EV.

## INTRODUCTION

The "California Initiative" stipulated that increasing proportions of new vehicles in California must be Zero Emission Vehicles (ZEV) and similar legislations have been passed in other US states [1-2]. This has impelled car manufacturers throughout the world to mass manufacture clean vehicles with electric power generation and storage capabilities. Some of the vehicles currently considered are the full ZEV, which include electric vehicles and fuel cell electric vehicles and the advanced technology partial EV, which includes hybrid electric vehicles with small petrol engine or fuel cell. By 2020, it is estimated that there will be 1 million vehicles in California with electrical generation and/or storage capabilities [3]. This large number of vehicles represents enormous power and energy storage potential. It has been proposed that charging stations are installed at parking lots or at shopping centre and places of work and at home. If these charging stations are designed with bi-directional power transfer capability, electrical power can flow from the car to the grid or vice versa. This technology is often referred to as "vehicle to grid" power, or V2G[4].

A demonstration project funded by the California Air Resource Board (CARB) and participated by Volkswagen and California Independent System Operator (ISO) was carried out in 2001-2002 using a VW Beetle EV. The EV was fitted with bi-directional grid interface and wireless internet connection. The California ISO send command using wireless internet to the vehicle based on current power need and knowledge of the vehicle battery current state of charge. The vehicle responds to command

with power to and from the grid. The vehicle automatically maintains the battery state of charge to comply with the driver usage requirement [5].

Despite the successful demonstration, the research work is mainly limited to active power control only. Also no study has been carried out to identify potential problems with having a large number these generation resources on the power system.

The paper describes a novel power electronics system that can be used to provide the bidirectional power transfer capability of the charger. The proposed bi-directional power converter can also provide reactive power and voltage support which theoretically does not make use of the energy of the energy storage in the EV.

The paper initially describes the potential problems that can be produced by unplanned introduction of EV to the electric power system. The paper then describes how the Electricity Supply System can capitalize on the energy storage in the electric vehicle to assist power system operation. As well as increasing reliability of supply and constraining power system operating and capital costs, the introduction of sufficient quantities of V2G system will help diminish Greenhouse gasses. The paper will finally describe a proposed power electronics systems developed at the Hong Kong Polytechnic University that can provide not only active power benefit but also reactive power and voltage support.

## INTRODUCTION OF ELECTRIC VEHICLES (EV)

The coming introduction of electric vehicles and their energy storage systems, which could be charged from the EV owner's residential supply, can offer the possibility of more quickly increasing energy storage capacity on power systems. This would only be useful if the Electricity Supply Industry could have access to portion of the EV battery stored energy. If no preparations are made for their introduction, once there are substantial numbers of electrical vehicles, the Electricity Supply Industry would face new problems.

### A. Difficulties

An approach presently proposed for EV's is for fast charging of battery banks at any time that suits the running of the EV. Taken to its natural conclusion, this will require the ability to charge batteries at 50 to 100 amps 240 volts, both at home and in parking lots [6]. The EV owner would be under no obligation to use off-peak charging and may well give priority to convenience rather than the savings offered by off-peak tariffs. In these circumstances the

utility will have neither direct control of the times nor the amounts of battery charging and could suffer severe consequences. Visualise the impact on the daily peak demand, when many owners return home at about 6 p.m. and recharge their EV batteries banks at 12kW to 24kW for each. At present the largest single domestic load would be a 2.4kW radiator or a 3.6kW hot water system. With the numbers of EV gradually increasing, the rate of load change at peak periods would worsen year by year, and with it the uncertainties and dangers posed to the power system. Every aspect of an introduction of EV, with no utility intervention, spells danger for the Electricity Supply Industry. In spite of a modest increase of electricity energy sales, the increasing peak demands will require heavy additional capital investments and still lead to a serious deterioration of power system operational security and reliability of supply.

#### *B. Preventing EV Problems using the V2G system*

To prevent the predicament that the power system would face once substantial numbers of EV are introduced, the Electricity Supply Industry needs to develop a new strategy, namely [7]:

1. To avoid increases of peak demand, utilities must be able to exert a tight control of the duration and the amount of charging on EV batteries.
2. Utilities should aim to access portion of the EV battery stored energy for their operational needs.

The first requirement can only be met if each EV could have a bi-directional charger, where the amount of power transfer can be controlled through GPS and wireless internet. The second aspect also requires a bi-directional charger so that the batteries is continuously connected to the AC network through inverters. When manufactured in quantity, the price of EV inverters would fall and provide a V2G system that can assist power system operation.

#### *C. Functions of the V2G system*

The range of functions that might be provided by vehicles can be segmented in two broad areas: (1) local services to benefit the electricity customer where the vehicle is connected, and (2) broad area services that benefit the operation of a power grid.

The local services category includes functions such as providing backup power for homes or businesses, local voltage stabilization/power quality improvement, and peak shaving for demand charge reduction.

The broad area services would be grid ancillary services. Ancillary services are power services (other than scheduled bulk generation) that are used by grid operators to maintain the reliable operation of the grid. Examples of ancillary services include spinning and non-spinning reserves – power generation capacity that can be called on short notice as needed.

The potential benefits that could be gained by the Electricity Supply Industry in tapping EV battery energy should prompt them to promote more EV. The community will be encouraged to swing to EV if provided with both convenience and low enough cost. To implement the proposed strategy, utilities should install bi-directional charger at parking places at work and shopping centers to allow control of charging the batteries in the vehicle. The vehicle will also need to be fitted with a wireless internet connection, allowing the remote control dispatch of its

power capabilities. The operating scenario for a vehicle with this capability is that it would be plugged in to the grid during most of the time it is not in use. For most urban use, there are two main periods of grid connection: (1) at home after work through the night to the following morning, and (2) at the workplace during normal working hours.

#### *D. Environmental Advantage*

Greenhouse gases are produced from the combustion of any carbon compound, be it coal, oil or petroleum. Internal combustion engines in motor cars have only 12% thermal efficiency and in city traffic congestion much of the energy is wasted whilst creating air and noise pollution. By contrast, thermal power stations have a 36-40% thermal efficiency. A pessimistic view of only 50% efficiency of battery charging for EV use would still provide an overall 18-20% efficiency [8]. Consequently EV's would provide a significant improvement in the reduction of Greenhouse gas emissions, while also removing a source of air and noise pollution in the heavily populated inner city areas. When EV replaces sufficient internal combustion vehicles in cities, the health and quality of life of residents will be considerably improved. This will translate into savings for taxpayers with the reduction of health care costs, as a consequence of lower noise levels and less air pollution. If the ESI can provide appropriate incentives to speed the community acceptance of EV, the Government could legislate to prohibit internal combustion cars from the inner city areas. Governments could also provide the community financial incentives whose costs would be recouped from the lower health care expenditures.

### POWER SYSTEM CONTROL WITH THE V2G SYSTEM

The V2G system can provide an extremely fast interface between the AC network and the Battery DC energy storage. They can produce both active and reactive power for the AC network, even though the batteries only store real (active) power.

At present the daily peak periods, when the fastest load changes occur pose the greatest problems because these changes are amplified by the losses in the network that connects to the distant power stations. An added difficulty is the higher loadings at peak periods, which make the network more vulnerable to disturbances that, at worst, could disrupt supply to many consumers. But peak periods, being of short duration, are only associated with a small proportion of the power system's daily energy consumption. If sufficient V2G systems are installed, it would not only reduce the annual maximum demand from the central generating stations, but reduce the day to day peak loads as well as filling daily load troughs when recharging the energy storage [7.9].

There are many advantages for the entire power system offered by the introduction of V2G systems.

#### *A. Improving Security*

The much faster responses of the V2G inverters, than turbo-generator governors, would react to quickly control the effects of any disturbance. At present these disturbance effects have time to be amplified before the slower mechanical devices can respond to suppress them.

Consequently the power system has to be made much more robust to survive severe disturbances. Not only would the power system not need to be so robust, because of the fast inverter responses, but also by curtailing the peak demands, the vulnerability of power system would be much reduced [7].

### B. Improving Reliability

With the tremendous advantages of locating V2G system in distribution networks, back-up supply would be close at hand even if the V2G systems were not in the consumer's installation. This would make a major impact on consumer reliability as 90% of interruptions to individual consumers are currently due to disturbances in the distribution networks.

### C. Impact on Generation

With sufficient quantities of V2G system to curtail daily peak demands, peaking power stations do not have to be manned or be run up. At light load periods, re-charging the energy storage allows base load generators to be run at higher, more efficient outputs and avoids the need to shut units down. Further, with a sufficient amount of energy storage, it would no longer be necessary to carry much spinning reserve on the generators.

#### THE PROPOSED CONVERTER FOR THE CHARGER OF THE V2G SYSTEM

The proposed converter is designed to control the current coming from the grid both in its magnitude (positive and negative) and in its waveform, irrespective what other load is connected to the system. By setting the magnitude to be positive, the converter converts AC grid power to DC for charging the battery and by setting the magnitude to be negative, DC power is converted from the vehicle to AC power at the grid frequency. The AC power from the vehicle can be used to power stand-alone loads or it can be fed to the grid. Safety systems similar to those employed with small distributed generation systems prevent the vehicle from feeding power into the grid when the grid power itself is down.

By knowing the energy that the vehicle needs based on the driving profile stored in the memory, and the current available energy in the battery, the operator can then decide whether the vehicle can supply power back to the grid during peak load to reduce some of the peaking demand.

Since the waveform could be easily shifted right and left, reactive power compensation can be easily provided to make the supply current either lagging or leading.

### A. Hardware

The hardware consists of:

- Real time accurate measurements of electrical quantities built around a Texas Instrument TMS320C31 3rd generation floating-point Digital Signal Processor (DSP). The board combines the TMS320C31's computing performance of up to 40 MFlops, with a versatile set of on-board Input/Output (I/O). This subsystem provides more complex functions like PWM, capture, timers and bit I/O,

based on a TMS320P14 micro controller DSP. Using a software based algorithm, this subsystem can be accessed like conventional I/O channels, but also can be programmed as a slave DSP. The DSP board has four (A/D) converters to sample the instantaneous values of two line voltages and two line currents during each sampling period. (The four A/D inputs can be measured and stored concurrently together with calculated power factor and power, as well as rms values of currents and voltages for any further evaluations). All transducer signals are filtered using external analogue filters to remove high frequency components prior to sampling by the ADC input section. The outputs of these analogue filters are then sampled at fixed time intervals (typically 100-1000  $\mu$ sec), the currents are digitised with 16-bit ADC and voltages are digitised with 12-bit ADC and processed in real time during every sampling interval and then stored.

- An intelligent High Power Inverter rated at 415V, 100A three phase output, with DC input of 110V, 100Ah. It employed Insulated Gate Bipolar Transistor modules as the switching devices with switching speed of more than 15kHz., each rated at 1200V and 200A with deadtime of 2.5 $\mu$ sec. The modules has been specially designed to protect the system from both internal and external fault and can in extreme circumstances run at twice at rated rating.
- The lead-acid battery bank for use in the EV chosen for the project is low maintenance air-vented type consisting of 19, 6V cells connected in series to provide 110V, 100Ah capability. Each battery pack can last for 10 hours at 10-ampere with end voltage equal to 1.8V per cell.

The system configuration is shown in Figure 1.

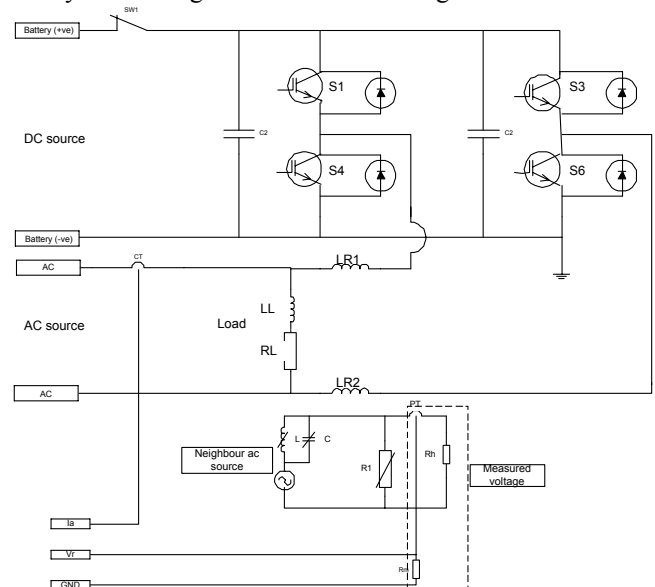

Figure 1 -- System Configuration

### B. Control Strategy

The control Strategy for the Battery Energy Storage System is based on Figure 2.

The current in the source is compared with a reference waveform, in this case the voltage across  $R_1$  in Figure 1. In Fig. 2, the transistors or IGBT's are switched

ON and OFF to ensure that the charger ( $I_C$ ) will supply or absorb the required current to force the supply current ( $I_S$ ) to follow the reference waveform both in magnitude and phase. As the capacitor (C) and inductor (L) are varied in Figure 1, a shifted waveform of the reference signal can be obtained. In this way the power factor of the supply can be varied, from  $50^\circ$  lagging to  $50^\circ$  leading, while at the same time the charger can be made to provide or absorb active power. As the reference is independent of the load current ( $I_L$ ) in Figure 2, the supply current waveform will be kept sinusoidal, even though the output current is non-sinusoidal.

**\* It is controlled to follow a reference waveform irrespective of load current and fluctuation in time.**

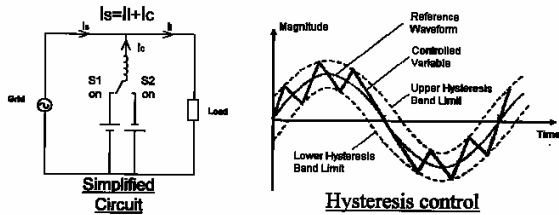

Figure 2. Control Strategy of the power converter

### RESULTS

The following shows the result from the laboratory experiment for different aspects of the converter capability.

#### A. Fast control of the charger from generating to charging

Figures 3 and 4 show the responses of the charger following a sudden change in the polarity of the reference signal from positive to negative value. Initially the input current is controlled at 4A in phase with the supply voltage. When the polarity of the reference waveform is reversed, the input current is now  $180^\circ$  apart from the supply voltage as shown in Figures 4(a) & (b). The charger is now pumping power back to the grid as shown in Figure 4(d). This demonstrates that the output of charger can vary from positive value to negative value.

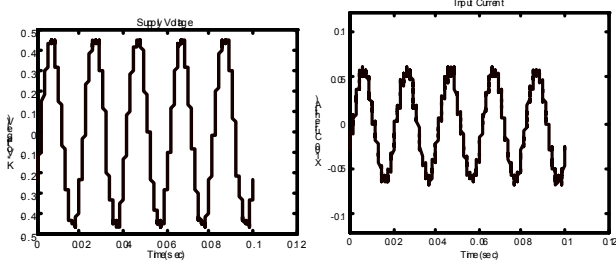

Figure 3(a) Figure 3(b)  
Figure 3: Charging operation

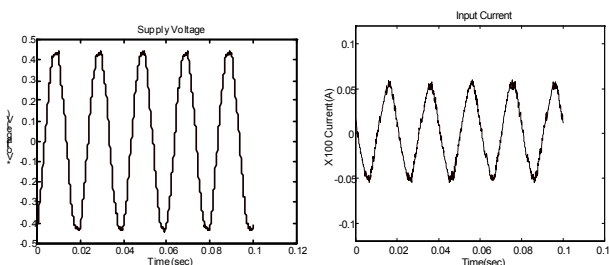

Figure 4(c) Figure 4(d)  
Figure 4: Discharging operation

#### B. Load Leveling

Figure 5 shows the potential operation of the V2G system for reactive power compensation. The load on the power grid is set to be inductive in value, so that without the bidirectional charger, the grid current will be lagging the voltage, but after the converter is connected, the grid current becomes in phase with grid voltage, showing the capability of the converter to provide reactive power compensation.

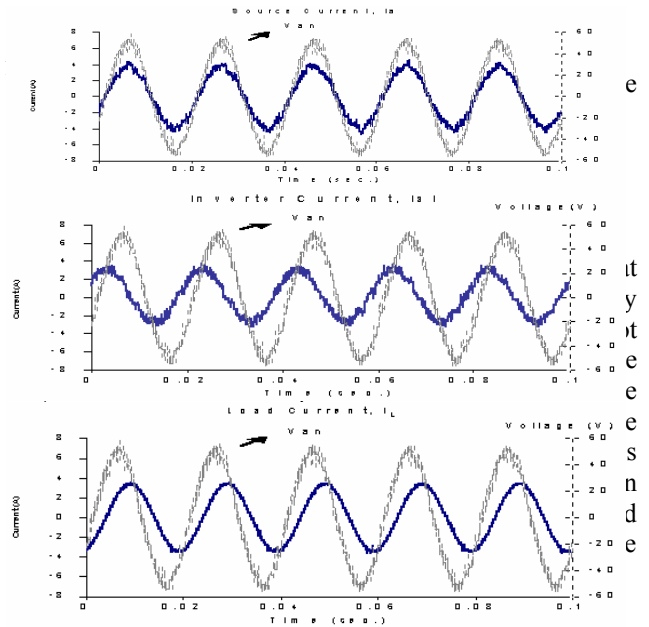

Figure 5: Reactive power Compensation

#### FUTURE OPERATION OF THE V2G SYSTEM [X]

In [X], a future scenario where tens of thousands of vehicles are connected to the grid performing ancillary services is envisaged. In such a case, the grid operator will not want to deal with each individual vehicle. Instead, the grid operator will want to have control over the aggregate capacity of the vehicles. An intermediary entity, called an aggregator, would manage the interactions between the grid operator and the connected vehicles. To the grid operator, the aggregator would appear to be a large source of rapidly-controllable generation or load - a good source of regulation capacity. The aggregator would contract with the grid operator through day-ahead and hour-ahead markets to provide regulation capacity. The grid operator and aggregator would communicate over a secure data link of the same type used to communicate with existing sources of regulation. The aggregator would receive regulation commands from the grid operator and allocates the required regulation out to the connected vehicles. A graphic of the system architecture is shown in Figure 6.

In this future scenario, it is expected that the EV will be charged to a predetermined level that will allow sufficient available energy for the EV, depending on the driver profile. Once this level is reached, the energy storage in the EV can be used by the system for regulation of the grid. Under no circumstances will the battery be allowed to be discharged below this level. A typical scenario is shown in Figure 7.

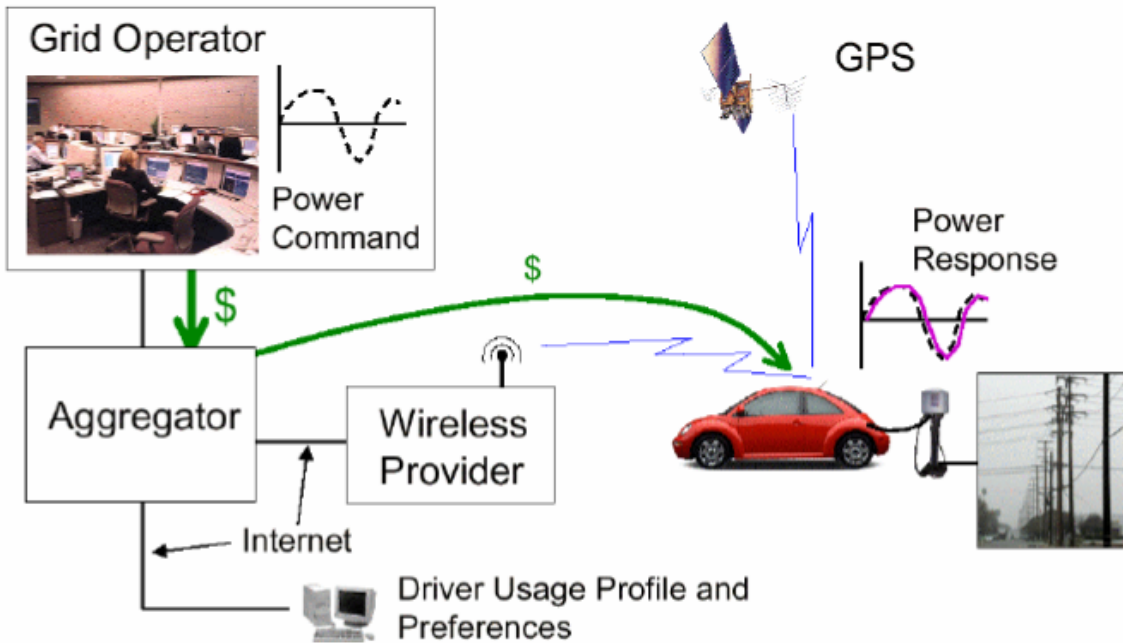

Figure 6: Futuristic architecture of the V2G system (From Reference 5)

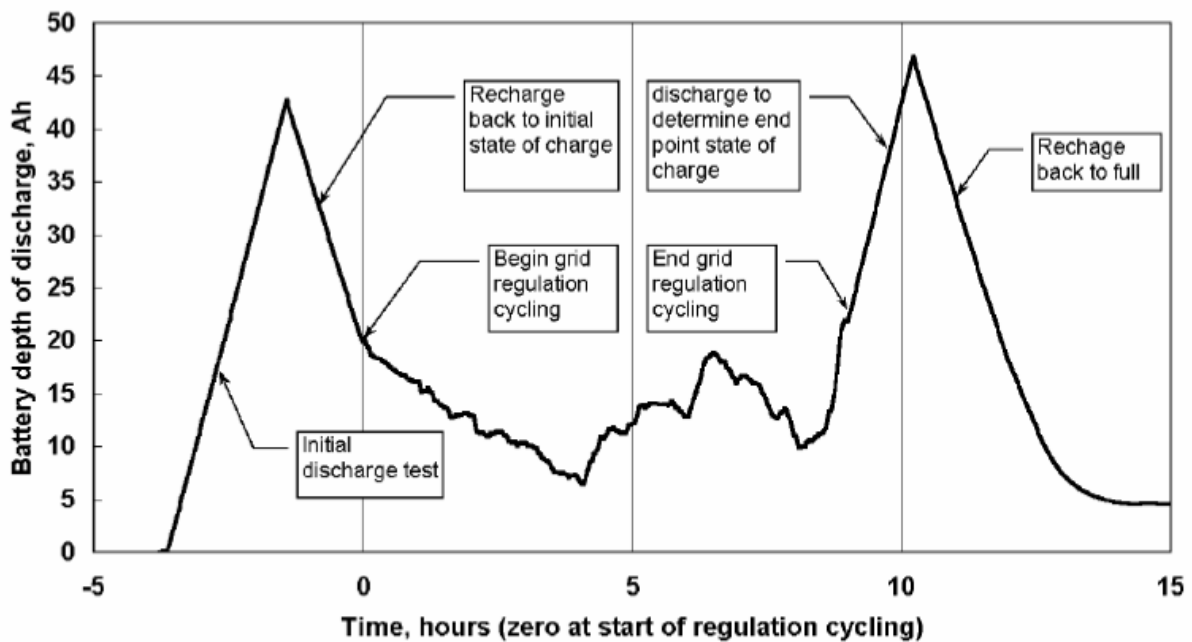

Figure 7: A scenario for a charge discharge cycle in the EV (From Reference 5)

#### CONCLUSION

Even though AC energy cannot be stored, fast responding inverters allow access to energy storage in electric vehicles using bi-directional power transfer. Capable of one cycle responses, the bi-directional converter can produce both active and reactive power, even though only active power is drawn from the energy storage in the vehicle, and their much faster responses are available without the mechanical wear suffered by turbo-generators. Of added importance, the V2G system will be located within distribution network, close to city consumers and fill the gap caused by the retirement of city power stations. Not only will sufficient quantities of V2G

system provide back-up power for essential city services, but also they could speed up restoration of the power system, should the grid be disrupted. The fast responses of V2G system would be particularly valuable for handling emergencies. For extremely severe multiple contingencies, when the danger to the grid could only be relieved by swift load shedding, the V2G system could be requested to swiftly increase their outputs to achieve the same effect, without interrupting consumers. Most of the emergencies could be relieved by only a short duration of "load shedding" and if the higher output were required for several minutes, only a minimal amount of stored energy would need to be expended.

Unless timely preparations are made, charging EV battery banks will produce severe problems and heavy expenses for the Electricity Supply Industry. However, if the necessary measures are taken to provide an infrastructure for the introduction of Electric Vehicles, access to the extra stored energy could greatly assist the power system, but can only come about with timely up front expenditures by the Electricity Supply Industry. Even though there may be a higher up front expenditure, much of this will be defrayed by the EV owner or the system operator.

#### ACKNOWLEDGMENT

The author gratefully acknowledges the financial support of the RGC of Hong Kong (Project Code: PolyU 5245/04E).

#### REFERENCES

- [1] California Air Resources Board (CARB), (2000a) "Staff Report for the 2000 Zero Emission Vehicle Program Biennial Review," August 7, 2000, Sacramento, CA, Air Resources Board.
- [2] California Air Resources Board (CARB), (2000b) "Staff Report: Initial Statement of Reason, Proposed Amendments to the California Zero Emission Vehicle Program Regulations," December 8, 2000, Sacramento, CA, California Environmental Protection Agency, Air Resources Board.
- [3] Kempton, W. and Letendre, S., "Electric Vehicles as a New Source of Power for Electric Utilities" *Transportation Research* 2(3), pp. 157-175, 1997.
- [4] Letendre, S. and Kempton, W., "The V2G Concept: A new Model for Power?" *Public Utilities Fortnightly*, 140(4), pp. 16-26, 2003
- [5] Brooks, A., "Vehicle-to-Grid Demonstration Project: Grid regulation, Ancillary Service with Battery Electric Vehicle", Report, AC Propulsion, December 2002. Prepared for the California Air Resources Board and the California Environmental Protection Agency
- [6] M.J. Reizenman - "Special Report on Electrical Vehicle: Electrical Vehicles" *Spectrum* Vol. 29 No. 11 November 1992 pp. 18-21
- [7] W.R. Lachs, D. Sutanto & D.N. Logothetis - "Power System Control in the Next Century" 95WM 107-3 PWRS IEEE Winter Power Meeting New York February 1995.
- [8] W.R. Lachs, D. Sutanto & G. Ledwich - "Distribution Control with Battery Energy Storage Systems" *Distribution 2000 Conference BRISBANE* 14-17th November, 1995 pp. 253-261
- [9] W.R. Lachs & D. Sutanto - "Battery Storage Plant Within Large Load Centres" *IEEE Transactions on Power Systems*. Vol.7 No.2 May 1992 pp. 762-769.