

# A DC-DC Converter Used as a Light Dimmer for Compact Fluorescent Lamps<sup>1</sup>

Dillian, T.P. WONG<sup>1</sup> Martin, H.L. CHOW<sup>1</sup> C.K. LI<sup>1</sup>

<sup>1</sup>Department of Electronic & Information Engineering,  
The Hong Kong Polytechnic University

**Abstract**—To face the challenge of possible global warming, the governments of developed countries around the world try to cut their carbon emissions by promoting the use of energy efficient appliances such that the standard of living of their people could be maintained with less overall energy consumption [1]. One of their moves is to replace inefficient incandescent lamps with compact fluorescent lamps (CFL) with high efficacy through legislation. However the majority of CFL available in the market cannot be used in conjunction with traditional Silicon Controller Rectifier (SCR) light dimmers such that certain replacements cannot be conducted as expected. Moreover, dimming the light output to a desired level is also a way of energy saving without degradation in living quality. Therefore this paper presents a practical light dimmer, which is essentially a dc-dc converter, that can be used in conjunction with the majority of CFL available in the market and the dimmer can be installed in a wall mountable housing like a conventional dimmer. The paper also provides the measured characteristics of a set of CFL under dimming control and evaluates the overall performance of the proposed light dimmer in conjunction with CFL. Finally, this paper gives a brief discussion on the possible impact on the efficacy and lifetime of CFL used in conjunction with the proposed light dimmer.

## I. INTRODUCTION

CFL operate similarly as their conventional counterparts, fluorescent tubes. Using phosphor coating on lamp tubes of CFL, visible light is generated through the conversion of UV light emitted from electrically excited mercury plasma. Based on this operation, CFL can achieve much higher efficacy than that of incandescent bulbs. In addition, CFL are usually designed with shape and size similar to incandescent bulbs such that, in maintaining the original lumen output, most of the incandescent bulbs employed in the existing lighting fixture can be easily replaced by CFL with one-fifth of the original electrical wattage. In general, CFL can enjoy a longer lifetime because, for a given lumen output, less heat is generated from CFL in a lighting fixture.

On a national scale, energy consumptions on lighting can be greatly reduced by replacing incandescent bulbs with CFL, e.g., in 2007, Australia became the first country [2] to restrict the use of incandescent bulbs and decided to phase out the sales of incandescent bulbs before 2010, and similar legislations are being established in other countries. Despite of the overwhelming preference for the replacement, there is a feature which may be

overlooked when comparing the characteristics of incandescent bulbs and CFL. The feature is the use of incandescent bulbs and CFL in conjunction with traditional SCR light dimmers installed in wall mountable housings.

The majority of CFL available in the market cannot be used in conjunction with traditional SCR light dimmers, in fact all these CFL carry a label which reads as “Not suitable for dimmers or electronics switches”; “Not for use with dimming circuit”; “Not dimmable” etc. for reminding the users.

A light dimmer, which is essentially a dc-dc converter, is designed and constructed to use in conjunction with the majority of CFL available in the market. The light dimmer can be installed in a wall mountable housing. Section 2 describes the ballast circuits in CFL and Section 3 proposes a method for dimming control. Section 4 presents the measured characteristics of some CFL under the dimming control. Section 5 describes the principle of operation and construction of the proposed light dimmer together with its measured performance such as achieved efficacy and the possible impact on the lifetime of the associated CFL.

## II. BALLAST CIRCUIT INSIDE COMPACT FLUORESCENT LAMPS

Most of the CFL available in the market employ simple electronic ballasts adopting typical voltage fed configuration as shown in Figure 1. This configuration is rapid start type [3] which heats the filaments and strikes the gas at the same time when starting. By examining the ballast circuit in Figure 1 in detail, it is surprising to reveal that the lamp current is almost constant for a wide range of supply voltages. The reason for this constant lamp input current properties is due to the current limit imposed by saturable transformer  $T_1$  which is used to cause oscillation for the gas ignition in start up phase and to maintain light generation in normal phase. Note that the secondary windings  $T_{1a}$  and  $T_{1b}$  of the saturable transformer are connected to the bases of transistors  $Q_1$  and  $Q_2$  in opposite phase such that the transistors are turned on and off alternatively whenever the magnetic field inside  $T_1$  collapses due to the current of inductor  $L$  reaches that the limit imposed by the saturable transformer. The oscillation frequency of the transistors could be estimated by the equation

$$I_{\text{sat}} = I_{\text{discharge}} + I_{\text{heating}} \quad (2)$$

where  $I_{\text{discharge}}$  is the tube discharge current,  $I_{\text{heating}}$  is filament heating current.

Because the lamp current is more or less a constant with respect to supply voltage, the brightness of the lamp is then determined merely by the applied electric field between electrodes of the lamp and it is clear the electric field between electrodes is proportional to the supply voltage. In other words, the brightness of the lamp can be controlled proportionally with the supply voltage and this property forms the basis of the proposed light dimmer.

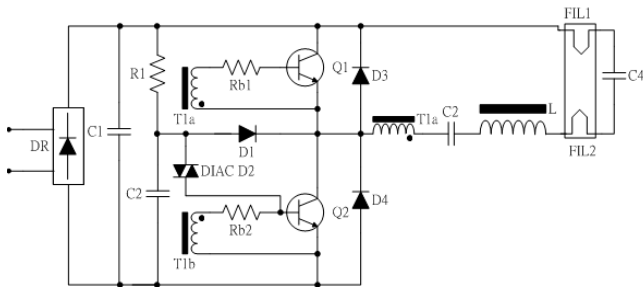

Fig. 1: Typical electronic ballast circuit with voltage fed configuration [4,5] employed in most of the CFL available in the market

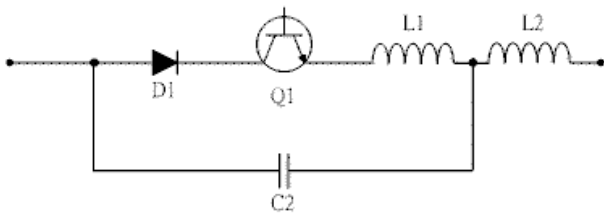

Fig. 2: Ac chopper CFL dimmer proposed by Yao in 2003

### III. METHODS OF DIMMING

CFL dimming can be achieved by decreasing the lamp discharge current or ballast switching frequency but both methods offer no simple and practical solution because the ballast circuits of the CFL usually cannot be accessed externally. Even through the above methods could provide a possibility to optimize the lamp filament heating current, they are only suitable for specially designed dimmable CFL with custom made dimmers. Therefore the simplest solution for achieving dimming of CFL is to adjust the lamp supply voltage such that the electric field energy between the two filaments can be changed accordingly. Although changing the lamp supply voltage should have some effects on the lamp discharge current and oscillation frequency, our major interest is still to facilitate a function of dimming on CFL available in the market.

Perhaps the simplest way for varying the lamp supply voltage is to place an adjustable turn ratio transformer between the ac mains and the CFL but most of the adjustable turn ratio transformers at mains frequency are

poor in efficiency, less than 60% and bulky in size. An efficient way to achieve an adjustable ac voltage from the mains was proposed by Yao [6] in 2003. He suggested a circuit making use of a high frequency switch operates in a region of 2 kHz to 50 kHz for chopping the mains voltage into many segments, and then takes the average of needed segments to regenerate a smaller, adjustable ac voltage at mains frequency. Figure 2 is the simplified ac chopper power supply circuit depicted in Yao’s patent. The idea is very similar to traditional switch mode power supplies except his chopper circuit is modulating an ac instead of a dc.

By re-examining the ballast circuit shown in Figure 1, it is clear that the ballast circuit converts the ac mains into a dc circuit by means of a rectifier, or in the other words, the ballast circuit is actually operating under a dc power supply. Therefore, this type of CFL can be simply driven by a dc power supply and the lamp output can be dimmed if the dc power supply is adjustable.

### IV. AC AND DC DIMMING CHARACTERISTIC OF CFLs

#### 4.1 Testing method

Tests are carried out to study the feasibility of dimming a conventional CFL using adjustable ac and dc supply voltages. In these tests, the samples shown in Table 1 are driven by a programming ac/dc source and then the corresponding light outputs are measured in unit of LUX. In the measurements, the tested lamp is mounted inside a home-made black box which blocks external light from influencing a light sensor placed at the top box. The light sensor and the tested lamp have a distance of roughly 45 cm.

Results in these tests are based on relative measurement, i.e., the recorded light output values under different supply voltages are compared with the nominal light output operated at 220 V 50 Hz ac mains or 300 V dc. Normalized luminous, power input and efficacy for different ac and dc supply voltages are plotted in Figures 3-8. The lamp input current, surface temperature, and oscillation frequency are plotted against different dc supply voltages in Figure 9, Figure 10 and Figure 11 respectively.

Table 1: CFL testing samples

Number	Brand	Rating
1. ----	Toshiba	5W
2. ----	Toshiba	11W
3. ----	Toshiba	25W
4. ----	Philips	8W
5. ----	Philips	11W
6. ----	Philips	20W
7. ----	Osram	11W
8. ----	Osram	13W
9. ----	GE	8W
10. ----	GE	12W
11. ----	DeluxS	7W
12. ----	DeluxS	15W
13. ----	B&Q	5W
14. ----	B&Q	11W
15. ----	B&Q	20W

4.2 Testing Results

Figure 3-8 indicate clearly that the brightness of CFL can be dimmed when there is a reduction in their supply voltage either in ac or dc. In addition, these figures show that CFL can achieve a wider dimming range and higher efficacy if they are operated using adjustable dc power supply. Figure 6 shows a desired linear relationship between output brightness and dc supply voltage. Therefore using adjustable dc supply voltage for dimming CFL is more practical. Figure 9 indicates that the lamp input current is roughly constant for dc supply voltage in the range of 100 – 300 V and this verifies the observation in Section 1. Figure 10 indicates that the lamp surface temperature reduces by 40% when the dc supply voltage varies from 300 V to 100 V. Figure 11 indicates that the oscillation frequency increases from 40 kHz to 60 kHz when the supply voltage varies from 300 V to 100 V.

The results of these tests indicate that when most of the CFL are dimmed down to 70% of their nominal output values and their efficacies are somehow improved by 10 - 20% due to the dimming, whereas the surface temperature of their lamps is decreased by 15% - 20% and the oscillation frequency of their ballast circuit is increased by 5 - 7 kHz.

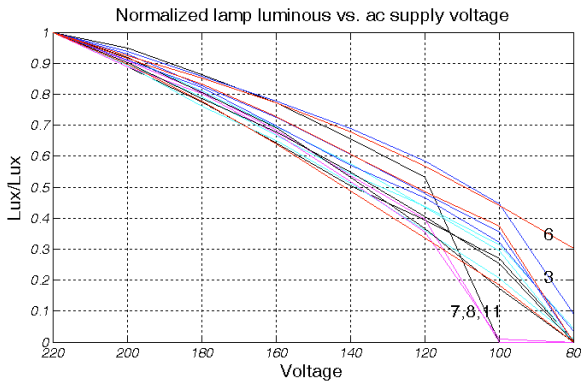

Fig. 3: Normalized lamp luminous vs. ac supply voltage.

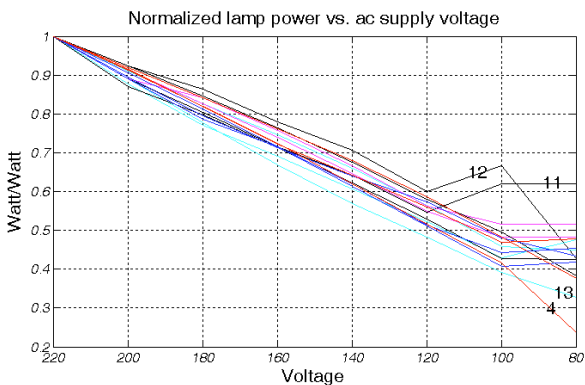

Fig. 4: Normalized lamp power vs. ac supply voltage.

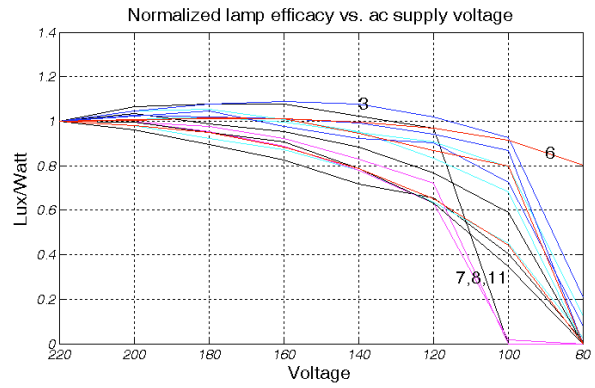

Fig. 5: Normalized lamp efficacy vs. ac supply voltage.

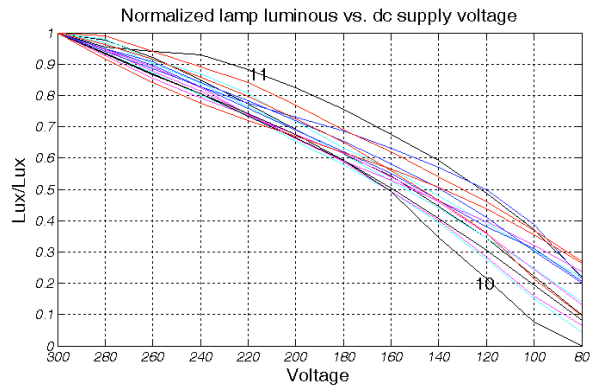

Fig. 6: Normalized lamp luminous vs. dc supply voltage.

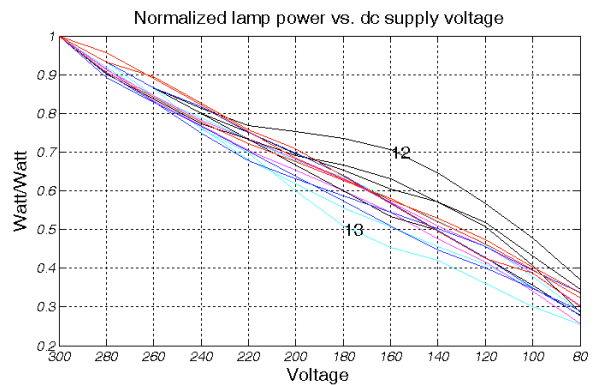

Fig. 7: Normalized lamp power vs. dc supply voltage.

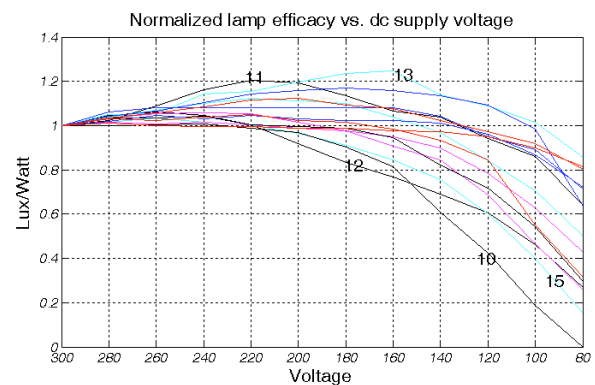

Fig. 8: Normalized lamp efficacy vs. dc supply voltage.

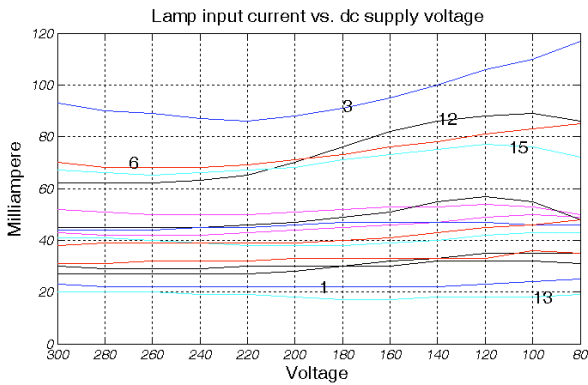

Fig. 9: Lamp input current vs. dc supply voltage.

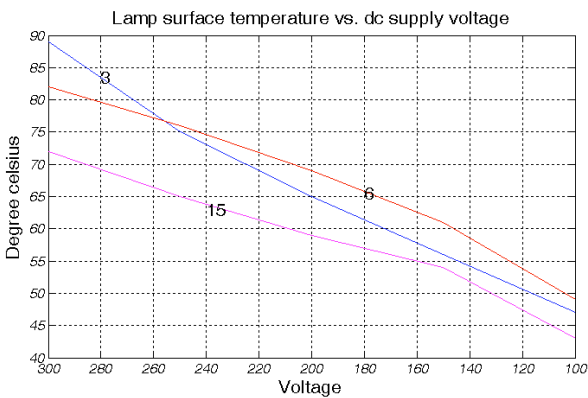

Fig. 10: Lamp surface temperature vs. dc supply voltage.

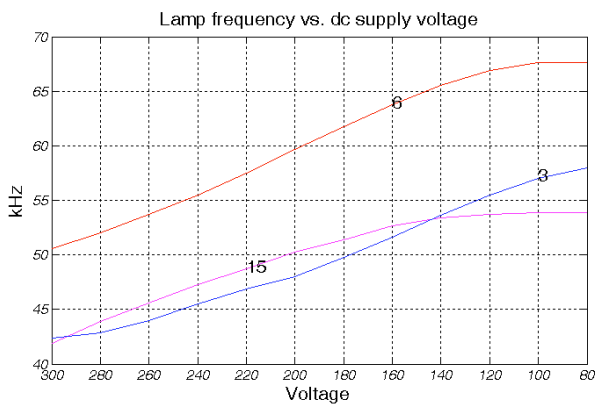

Fig. 11: Lamp frequency vs. dc supply voltage.

#### IV. THE PROPOSED LIGHT DIMMER

A light dimmer which can be used in conjunction with available CFL in the market is proposed. The light dimmer should be able to be turned on, turned off and adjusted its brightness electronically through the control of a microprocessor so as to reserve a possibility of extending the control to under wireless mode in the next phase of development. Apart from dimming a single lamp alone, the dimmer should be able to drive several lamps simultaneously with maximum total power rating of 100 W, and the circuit has to be fit inside a standard wall-mountable housing BS1363. The standby power of the dimmer when all the lamps are off should be less than 0.3 W, while the total loss of the dimmer at

maximum 100 W power output should be less than 2.5 W. Therefore apart from achieving the required dimming functionality, the considerations for improving circuit efficiency and reducing the physical size become dominate in the design.

##### 5.1 Open loop buck converter as an adjustable dc source

An open loop buck converter as shown in Figure 12 is proposed to use as the adjustable dc source for dimming the outputs of CFL. It seems that there is no big difference in idea between the one proposed by Yao [6], ac chopping, and this proposed dimmer because both adopt the technique of pulse width modulation to regulate the output voltage. In fact, Yao proposed dimmer chops the mains voltage directly, whereas the current proposed dimmer chops the rectified dc voltage instead. In addition, the measurement results in Section 4 indicate that it is better to drive CFL in adjustable dc.

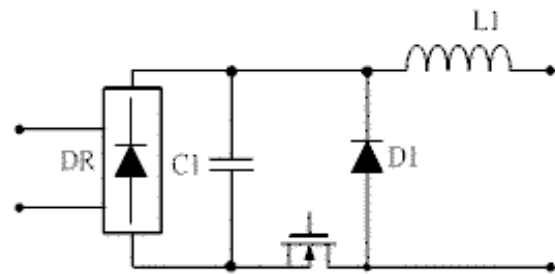

Fig. 12: Open loop buck converter as an adjustable dc source

##### 5.2 Considerations for simplifying the design

Referring the ballast circuit shown in Figure 1, the existence of rectifier and mains capacitor in the ballast suggests there is no need to install an output capacitor to the buck converter and this will lead to a reduction in space and cost. Besides, the buck converter operates at kHz range such that the actual input dc voltage to CFL has less ripple compared with that when the CFL operating with ac mains frequency.

For the sake of a simpler design, the proposed dimmer does not allow the end-users to set the brightness at the very beginning, say the first 20 seconds after the lamp has been turned on for avoiding any possible influence on the ballast circuit in the process of its tube ignition. That means the lamp must be dimmed starting from its full brightness. In contract, one could do something on the lamp supply deliberately when starting with the attention of optimizing the tube striking in some sense, but this is not the major interest in this paper and hence the dimmer merely is designated for the working region where the tube has been fully ionized.

The dimming characteristics of different bands of CFL shown in Figure 3 (with adjustable ac voltages) and Figure 6 (with adjustable dc voltages) indicate the amount of dimming control can vary between different bands of CFL under the same input voltage range. Therefore, the control of the proposed dimmer is under open loop, i.e., the end-users effectively enjoy adjusting the lamp input voltage by monitoring the level of

brightness until they get their desired luminance. However, the experiment results indicate that identical lamps from the same manufacturer may have different dimming characteristics, i.e. some lamps are slightly brighter than the others under the same supply voltage. Most of the lamp applications do not require electrical isolation for safety considerations and this situation allows the MOSFET switch in the proposed dimmer can be directly driven by a controller and placed at the bottom side as shown in Figure 12 without employing any transformer.

5.3 Difficulties encountered

One of the difficulties is to achieve a wide range of loading conditions from a single CFL to several multiple CFL while maintaining excellent power efficiency. The loss of the light dimmer should be minimized because the circuit is completely covered by wall-mount housing in real life application stopping any flash air to cool down the circuit. In order to minimize MOSFET switching loss and inductor hysteresis loss, the switching frequency of the buck converter must be kept as low as possible. The switching frequency of 20 kHz is employed in this prototype. All these lead to a relatively large inductance value on L<sub>1</sub> shown in Figure 12, e.g., a value of 13 mH inductor which is built by 510 turns winding on an MPP core 55895.

At first, we thought it is not necessary to operate the converter at the same low frequency, say 20 kHz, at all conditions because changing either the inductance (variable inductance) or switching frequency (variable frequency) manually or electronically to fit a particular loading condition can meet the level of required efficiency as well. For instance, a current sense circuit could be implemented gradually increasing the switching frequency once the load current reaching the threshold values, this could help in reducing or optimizing the value of the inductor.

In fact, the converter can also be operated in discontinuous mode when it is under light load condition. The only problem perhaps is CFL may blink when it is dimmed too low because the dimmer may generate an unstable output voltage when the duty cycle of the buck converter is too small. However, in real situation, the abovementioned scenario should not happen because end users will increase output of the dimmer once they encounter the blinking situation. Therefore the only drawback of discontinuous mode operation is a narrower dimming range. In the case of our application, the light dimmer supposed to work best when it is under high power, i.e. we keep a fixed switching frequency of 20 kHz for simpler design, i.e., there is a compromise between simplicity and performance.

5.4 Block diagram of the light dimmer

Figure 11 shows the block diagram of the evaluation board. The circuit contains two converters, a buck converter and a flyback converter which is used to step down the rectified voltage to 5 V and 12 V to power the

microprocessor and all other related controlling circuitries at any time in application. During standby, all lamps are off and the flyback converter will be operated in discontinuous mode and all unnecessary circuitries will be shut down electronically. Therefore the standby power is very small. The buck converter is used to drive CFL with an output voltage in the range of 80 ~ 300 V and total maximum power rating up to 100 W. Two buttons are provided for the user to step the brightness up or down and turn the CFL on or off. Current sense here is used to prevent any possible overload, e.g., short circuit.

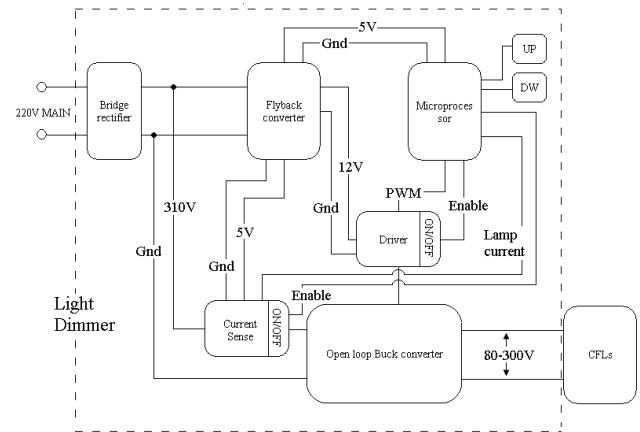

Fig. 13: Block diagram of the light dimmer

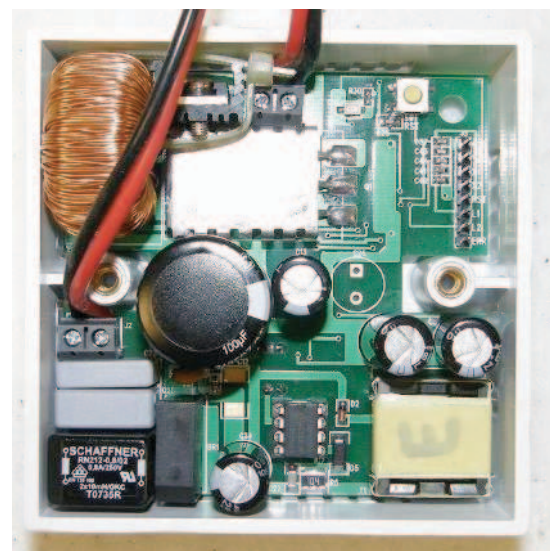

Fig. 14: Evaluation board of 100 W CFL light dimmer

## 5.5 Experimental evaluations

### 5.5.1 Testing Methods

The evaluation board of the light dimmer is inserted between the CFL and 220 V ac mains to dim the lamp at different levels. Input power, output power and brightness of lamps are analyzed in the tests.

In these tests the home-made black box is no longer used, and the dimmer drives five CFL simultaneously. During the measurement, CFL are installed in general lamp fixtures and a light sensor is placed at suitable location for the tests. In this experiment, only Philips 20W warm white CFL are tested.

### 5.5.2 Testing Results

Figure 13 shows the evaluation board of the light dimmer and it has a size which is small enough to put inside a standard wall mountable housing and this proves that the light dimmer is a practical replacement for the conventional SCR light dimmer. The efficiency of the light dimmer is about 98% at 100 W output. Figure 14 shows the dimmer loss versus different output power level. There are 15 dimming levels in the proposed light dimmer. Figure 15 shows the relative brightness output for each dimming level when the dimmer driving five Philips CFL.

The functionality and performance of the evaluation board is quite good and the tests show that using a buck converter to dim CFL is practical and feasible.

### 5.5.2 Efficacy

The efficacy of fluorescent tubes is directly related with the frequency of their driving source. As mentioned in [7], a discharge tube should be operated with frequency higher than 20 kHz, otherwise, extra energy is need for building up the discharge as the recombination of ions and electrons is fast when below 20 kHz. However, higher frequency do not always mean better, there is a duration called "nature time" which is time an excited atom will stay in its high energy level before releasing energy by jumping down to a low energy level. Therefore, if the driving frequency is so high such that the rate of excitation-emission is unable to catch up with the frequency, there will be a reduction in efficacy as the amount of heat created increases while the amount of light emission remains. Usually, the optimum frequency is between 30 - 40 kHz. Above those frequencies, the emission of light will be not increased because of the natural time of mercury atom.

In our measurements, efficacy is generally increased when the supply voltage is greater than 160 V. In this region frequency is lie between 40 kHz to 50 kHz. Below 160 V, efficacy drop fast and the frequency drifts closer to 60 kHz.

### 5.5.3 Lifetime

Death of lamp usually is because of the deterioration of the filament emissive coating to a level where the same strike voltage is no longer enough to ionize the gas or

electron-emissive. The ratio of loss of emissive coating is directly related with the cathode temperature both in lamp starting and in operation [8]. If the temperature is too high, the emissive mix as well as the tungsten material of the filament will be evaporated to a higher level [7].

In our measurements, we find there is a reduction in surface temperature when dimming, but we give no evidence of identifying this temperature reduction is contributed by the decrease of filament heating current or the decrease heat generation from gas reaction or both. However, it seems that the filament should be a bit cooler when dimming as the reduced surface temperature should help in heat dissipation. Nonetheless, we do not perform any life time test in this study, and we cannot make any conclusion on the effect of life time about our proposed light dimmer.

## V. CONCLUSION

A dc-dc converter, an open loop buck converter has been proposed to act as a light dimmer for CFL available in the market. Based on experimental results obtained, the proposed dc-dc converter provides a practical and feasible way to dim most of the CFL. The dimming is in the range of 15%-100% and the efficiency of the converter itself is 98% for 100 W output. The circuit size is small enough to put into a standard wall mountable housing. If the dimmer is required to be highly efficient, low loss and at the same time be able to work for different loading conditions, say one to five lamps with a wide dimming range, the converter requires a huge inductance which may be difficult to produce in mass production.

Regarding the lifetime of lamps, the most critical point is their filament temperature. In this study we show no evidence on any reduction of filament heating current when there is a reduction on the CFL supply voltage, we merely find out there is a temperature reduction on the CFLs surface. Therefore, we cannot make any comment on the influence of the CFL lifetime with reference to our proposed light dimmer at this moment.

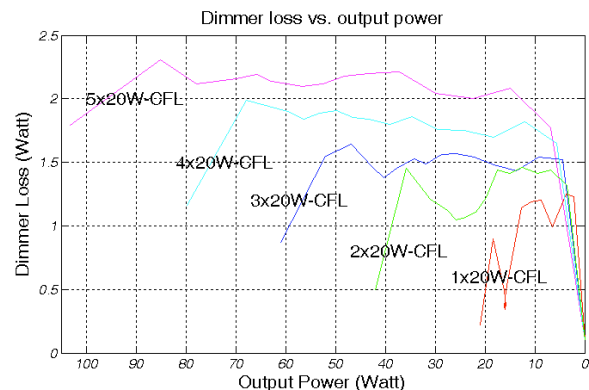

Fig. 15: Dimmer loss vs. output power for different loads

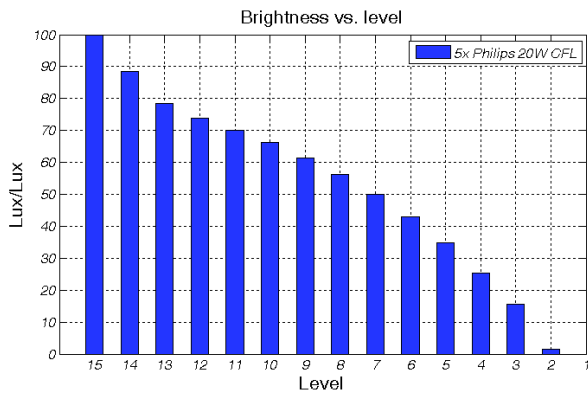

Fig. 16: Brightness vs. level

### REFERENCES

[1] L.R. Brown, J. Larsen, J.G. Dorn, and F.C. Moore, "Time for plan B cutting carbon emissions 80 percent by 2020," Earth Policy Institute

[2] "New measures tackle spiraling energy consumption in homes," Media Release, Australian Federal Government, Jun. 5, 2008.

[3] K.W. Booty, G. Forrler, B. Hitchcock, N.C. Grimshaw, W.D. Kirkland, N. Maiale, R.D. Sierleja, M.A. Stein, J. Sulcs and H. Wolfman, *DG-8-96 Ballasts and the Generation of Light*. New York: IESNA, 1996.

[4] M. Bairanzade, J. Nappe, and J. Spangler, "The Electronic Control of Fluorescent Lamps," Motorola Semiconductor Technical Data AN1049, 1990

[5] R. J. Haver, "The ABC's of DC to AC Inverters," Motorola Application Note AN-222.

[6] X.L. Yao, "Dimmer for energy saving lamp," U.S. Patent Application 2003 0222604 A1, Dec. 4, 2003.

[7] A. Heidemann and W. Denz. "Specifications for the operation of preheated cathode fluorescent lamps on electronics ballasts," in *IESNA Annual Conference*, Aug. 8-12, 1993, pp. 751-758.

[8] Y. Ji, R. Davis, C. O'Rourke and E.W.M. Chui, "Compatibility testing of fluorescent lamp and ballast systems," *IEEE Trans. Ind. Appl.*, vol. 35, no. 6, pp. 1271-1276. Nov./ Dec. 1999.