

# Computation of the In-Wheel Switched Reluctance Motor Inductance using Finite Element Method

T.W. NG<sup>1</sup> K.W.E. CHENG<sup>2</sup> X.D. XUE<sup>3</sup>

<sup>1</sup> Department of Electrical Engineering, The Hong Kong Polytechnic University, Hong Kong  
E-mail: eetwng@polyu.edu.hk

<sup>2</sup> Department of Electrical Engineering, The Hong Kong Polytechnic University, Hong Kong  
E-mail: eeecheng@inet.polyu.edu.hk

<sup>3</sup> Department of Electrical Engineering, The Hong Kong Polytechnic University, Hong Kong  
E-mail: eexdxue@polyu.edu.hk

**Abstract**—In this paper, inductance of an In-wheel Switched Reluctance Motor (SRM) would be computed by using the MEGA software. MEGA, a computer simulation program that model the electromagnetic devices, solves the low frequency subset of Maxwell's equations using Finite Element Method (FEM). Magnetic field strength would be computed in accordance with the SRM specifications. With different values of current injected to different phases, particular elements' field strength can be computed and field contours can be visualized. Field Strength along the stator pole would be achieved and would be used to calculate the inductance of the SRM. Computed results could be a reference compared with the experimental results and analytical calculated ones.

**Keywords:** FEA, in-wheel motor, SRM

## I. INTRODUCTION

With a growing concern on carbon-dioxide emission reduction in vehicles, electric vehicles (EV) which adopted various methodologies to convert electrical energy to mechanical forms are developed to deal with environment protection issues. [1]

One of the modern methodologies adopted in EV would be the In-wheel Switch Reluctance Motor (In-wheel SRM). The concept of the SRM has been published for a long time. It has several advantages over tradition Induction Motor: They are simple in construction, higher power density and efficiency, and higher torque-inertia ratio due to the absence of the rotor windings. However, only a few engineering applications adopted such technology in machine fabrications due to the complicated control system. With the aid of the modern advanced micro and power electronics, the cost of the SRM drive system is made down to a level which is competitive with the system based on other DC and Induction Motor technologies. [2, 9]

Motors with concentrated winding on the stator may have high cogging torque and the electromagnetic torque can have ripples due to the currents' imperfect waveform. [3] With the aid of computer simulation, such problems can be foreseen before the prototype is being fabricated. Thus reduce the cost and time of design.

## II. MEGA FEM SIMULATION

### 1. Theory

The MEGA software had been developed at the University of Bath as an electromagnetic field simulation tool [4].

Digital Reference: K210509121

The MEGA software adopted four Maxwell's equations which defined the field equations.

$$\nabla \times H = J \quad (1)$$

$$\nabla \times E + \frac{\partial B}{\partial t} = 0 \quad (2)$$

$$B = B(H) \quad (3)$$

$$J = \sigma E \quad (4)$$

### 2. Specification

Table 1 shows the specification of the in-wheel SRM. In accordance with the given specifications, a two-dimensional in-wheel SRM model would be built to investigate its characteristics. It should be note that the dimension, together with the material which the SRM is made of would be specified in the modeling stage. The accuracy of the simulated result is greatly depends on the number of nodes and elements used to build the model. The larger number of elements used in the model, the higher precision result can be achieved.

**Table 1: Specification of 4 phase In-Wheel SRM for Examining FEA from MEGA Software**

Number of stator poles	8
Number of rotor poles	6
Rated current	20A
Outer-diameter of stator (D <sub>0</sub> )	194 mm
Inner-diameter of stator pole (D)	98 mm
Length of air gap (g)	0.3 mm
Stator pole arc	22 degree
Rotor pole	23 degree
Shaft diameter (D <sub>sh</sub> )	28 mm
Height of stator pole (h <sub>s</sub> )	29.2 mm
Height of rotor pole (h <sub>r</sub> )	22.74 mm
Number of turns per phase	172
Number of turns per pole	86
Height of winding	25.2 mm
Width of winding	8.33 mm

### 3. Procedure

The model we built follows three general stages. First, we create the model using pre-post processors VIEW command. In this stage, nodes and elements of the model are created. Elements' properties would be set such that all elements in the model are identified and grouped as different regions. Parameters would also be inputted before the computations start. Second, the created model is solved by the SOLVE command. During this stage, computation and the simulated model is made. Groups of

Maxwell's equations which represent the model would be sent to solver for computations. After the equations being processed, the model can be post-processed for analysis, or be further edited by VIEW command.

### 3.1 Pre-solve stage

Nodes are created to construct the outline of the model. Meshes (elements) are formed by joining the constructed nodes. Both nodes and elements have to be checked before executing the solve command in order to compute a correct result. To ensure all nodes are connected and meshes are correctly created, unassigned nodes and overlapped elements would be eliminated by MEGA during the checking process in constructing two-dimension model. The files which contain co-ordinates of node, elements, outlook of model and equations would be generated after checking process is completed. Model built can only be solved only when the above files are saved and present in the current directory.

### 3.2 Processing stage

The saved data would be read by the solver and the model would be solved by the adopting the Maxwell's equations. The MEGA solver can process a number of files simultaneously and would show the status of the files being processed once it is called. A new file which contains answers for the model would be created after computations finished.

### 3.3 Post-processing stage

Simulated results can be viewed by retrieving the data from the answer file after computations finished. At this stage, any amendment made to the model would not take effect to the answer file unless the amended model is checked, saved and processed. One of the major purposes of post viewing is that to check that the problem has been correctly specified. A number of ways can be done to achieve this. Different scalar and vector quantities can be examined by various commands accordingly.

## III. IMPLEMENTATION OF THE IN-WHEEL SRM MODEL BY USING MEGA

A variety of home-made FE models [5]-[6] and commercial software packages [7]-[8] are able to simulate the behavior of the whole drive system – motor and converter. In this paper, focus would be put on the motor characteristics, with the motor control circuits and converters omitted.

### 1. Separate model implementation

The stator and rotor parts are created separately in our In-wheel SRM model. This is because the investigation of the inductance involves various rotor positions. For simplicity, rotor models are created at different angle positions and are attached to one stator model. Fig.1 shows part of the rotor model built at fully-aligned position. Note that from the Fig.1 the area inside the rotor has no nodes or elements where the stator's elements would be implemented afterwards

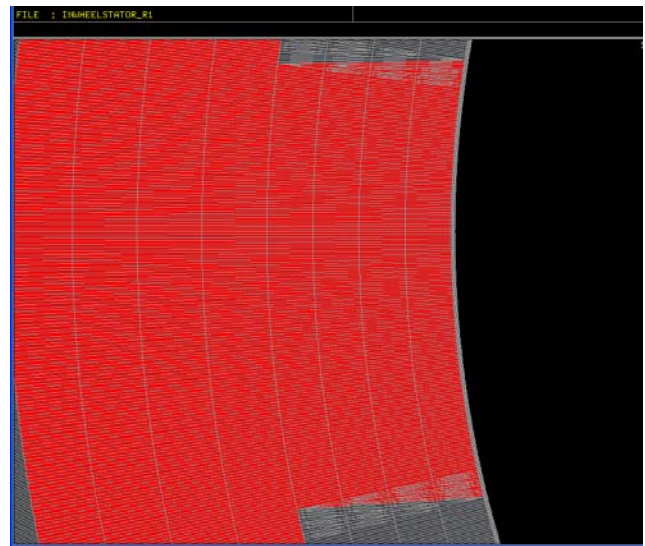

Figure1: Rotor Elements

In the model combination process, elements of the second read-in model (stator part) may overlap the elements of the original one. The MEGA program would check for the errors after the model combinations. Any duplicated elements and unassigned nodes would be eliminated during the checking process if they are found. Fig.2 shows the stator-rotor model at fully-aligned position after combination.

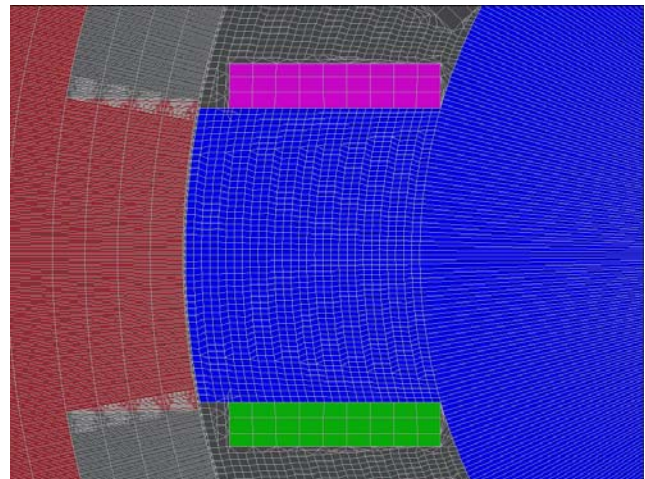

Figure 2: Rotor and stator elements with regions defined.

### 2. Region definition

Different regions were defined to identify the different parts, as well as material properties, of the In-wheel SRM. Regions can only be identified and material properties can only be assigned once meshes are formed. In Fig.2, the rotor, stator and coils are identified as shown. Ports are edited to the coil regions of the in-wheel SRM by specifying the current magnitude, number of turns in coil, direction and other required parameters. The permeability of both stator and rotor is specified by inserting B-H characteristics of D23-0.5mm silicone steel in order to get a more precise result.

### 3. Uneven distribution of the nodes and meshes

The combined model consists of over 50,000 elements and is mainly distributed around the air gap. That is because the air-gap plays a major role in the torque production. In the electromagnetic conversion most of the energy is stored within this thin band. [9] The boundary of the finite-element model is surrounded by air with enough

thickness, whose magnetic permeability is much smaller than that of magnetic materials. Its purpose is to ensure the magnetic field produced by the coil is totally trapped inside the combined model to form complete flux loops. Fig.3 shows the combined model before it is put to MEGA solver.

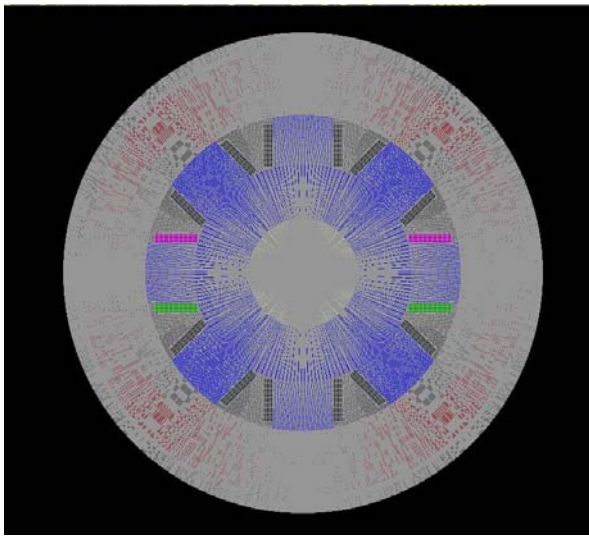

Figure3: Combined In-wheel SRM model for FEA  
IV. SIMULATION RESULTS

1. Fully-aligned position

The Fig.4 below shows the flux distributions of the in-wheel SRM at 20A with one phase excitation at fully-aligned position after the model is put to the MEGA solver. The flux lines pass through the air gap and go into the stator because a strong magnetic field is formed by the coil with high current excitation. The rotor is fully magnetized and formed a complete loop with the stator. The MEGA solver also shows satisfactory result on the permeability of material chosen. The flux lines, which have no tendency passing through non-excited poles under current excitation conditions while they complete loops only through the excited pole verified the correct choice of the material. Under the circumstance of the material permeability is too high, the flux lines would complete its loop at adjacent poles rather than at the excited ones. And flux lines would spread throughout the whole model if the material permeability is too low.

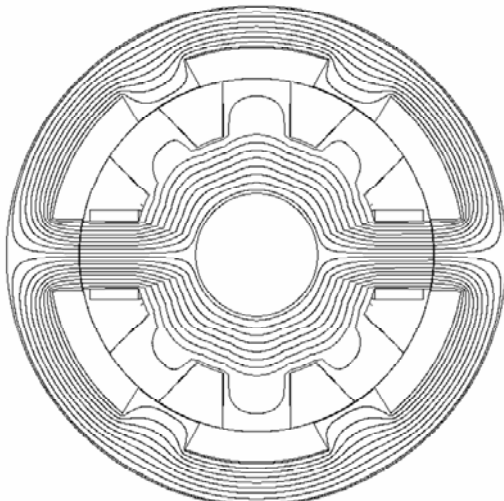

Figure 4: Simulated Flux distribution for fully-aligned position.

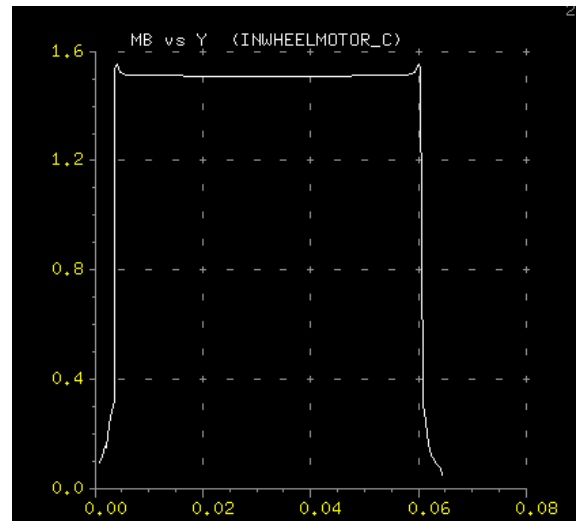

Figure 5: Modulus of magnetic field along the excited stator poles at fully-aligned position.

2. Fully-unaligned position

The Fig.5 below is the simulated result of the in-wheel SRM whose rotor is at fully-unaligned position, with other parameters being unchanged.

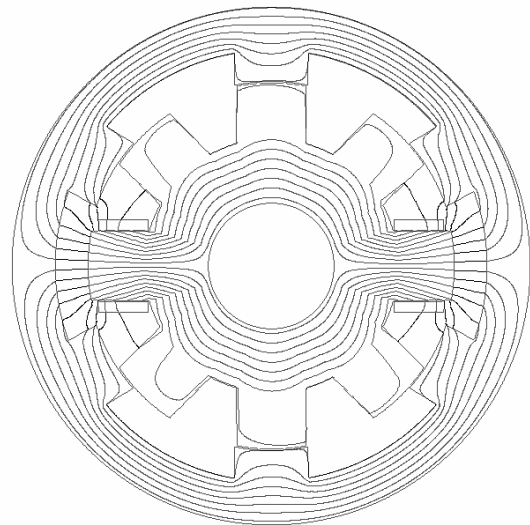

Figure 6: Simulated Flux distribution for fully-unaligned position. From the simulation result showed as above, no flux leakage goes to the adjacent stator poles to form any complete paths at fully unaligned position.

The total flux linkage is the surface integral of the elements' magnitude of magnetic field, which is perpendicular to the flux lines. Line integral would be adopted instead because of the models' 2D scale. The magnetic field integral along the pole should be chosen to cut all the flux lines in order to compute the total flux linkage.

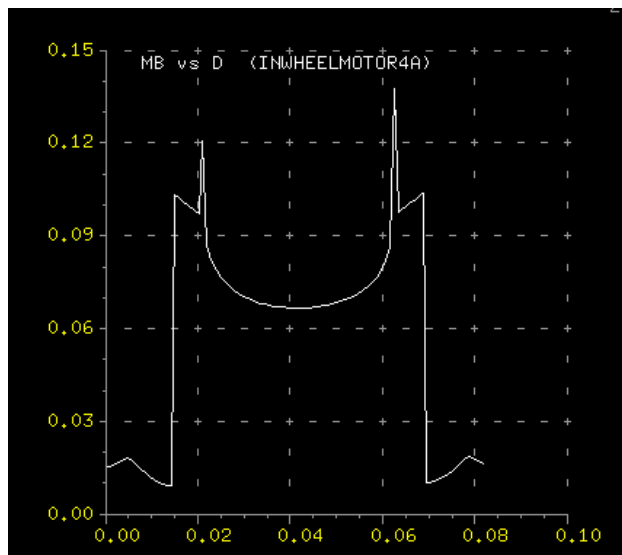

Figure 7: Modulus of magnetic field along the excited stator poles at fully-unaligned position.

By MEGA solver, the flux linkage of the in-wheel SRM is computed at fully aligned position and fully unaligned positions respectively. The data obtained is used to calculate the inductance by the following formula.

$$\Psi_{ph} = N * \int B dA \tag{5}$$

$$L_{ph} = \frac{\Psi_{ph}}{I} \tag{6}$$

From the computed modulus of the magnetic field, the inductance can be calculated whose range at fully aligned position fully unaligned position. Table 2 shows the inductance of the SRM at the two positions, with different current values injected to the coil.

**Table 2: Inductance of in-wheel SRM at fully-aligned and fully-unaligned position with different current injected to the coil.**

Current(A)	Inductance at fully unaligned position	Inductance at fully aligned position
0	0	0
2	0.117004	2.979935
4	0.234009	5.959406
6	0.351015	9.036791
8	0.468021	12.15608
10	0.585029	15.2786
12	0.70204	18.39361
14	0.819048	21.50382
16	0.936059	24.58193
18	1.053075	27.37114
20	1.17009	29.31955
22	1.287105	30.59759
24	1.40412	31.22831
26	1.521135	31.35021

## V. CONCLUSION

The flux distribution diagram for the in-wheel SRM is generated by Finite Element method. With the aid of MEGA, we also computed the integral values of the modulus of the magnetic field which are used to compute the inductance of the SRM. The simulated result shows a significance of accuracy and it can verify with the experimental stages when the SRM is put to test.

## REFERENCE

- [1] C.C. Chan, "The State of the Art of Electric and Hybrid Vehicles", Proceedings of the IEEE, Vol. 90, No. 2, February 2002, pp. 247-275
- [2] Benjamin P. Loop and Scott D. Sudhoff, "Switched Reluctance Machine Model Using Inverse Inductance Characterization", IEEE Transactions on Industry Application, Vol. 39, No. 3, MAY/JUNE 2003, pp.743-751
- [3] Y.P. Yang, Member, IEEE, Y.P. Luh, and C.H. Cheung, "Design and Control of Axial-Flux Brushless DC Wheel Motors for Electric Vehicles—Part I: Multi-objective Optimal Design and Analysis", IEEE TRANSACTIONS ON MAGNETICS, Vol. 40, No. 4, July 2004, pp. 1873-1882
- [4] MEGA tutorial, University of Bath
- [5] S. Brisset and P. Brochet, "Numerical simulation of the transients of a switched reluctance motor using an electronic-magnetic-mechanical coupled finite element model", International Conference on Electric Machines (ICEM) 1994, pp. 402-406, September 1994.
- [6] G. Manot, Y. Lefevre, H. Piquet, "Integration of Feed Back Control in a Field Circuit Coupled Model", International Symposium on Electromagnetic Fields in Electrical Engineering (ISEF) 2001.
- [7] Flux2D, www.cedrat.com
- [8] Opera2D, www.vectorfields.com
- [9] K. Cakir and A. Sabanovic, "In-wheel Motor Design for Electric Vehicles", AMC'06-Istanbul, Turkey, 2006, pp. 613-618