

# An Accurate Vehicle Gasohol Delivery System

Hongwei WANG<sup>1</sup> Yanbo CHE<sup>1</sup> K.W. Eric CHENG<sup>2</sup> Zhan-gang YANG<sup>1</sup>

<sup>1</sup> School of Electrical Engineering & Automation, Tianjin University, Tianjin China.  
E-mail: ybche@tju.edu.cn

<sup>2</sup> Department of Electrical Engineering, The Hong Kong Polytechnic University, Hong Kong,  
E-mail: eecheng@polyu.edu.hk

**Abstract** –Because the Vehicle Gasohol has the merit of low pollution and energy saving, it is extensively spread in recent years. This paper introduced the design scheme and implementation process of an accurate fuel delivery automation control system in an oil store-plant. A centralized control scheme is adopted in this system, where a C200HX series OMRON PLC works as its central controller, communicates with an industrial computer under RS-232 protocol. The system works precisely and proves to be reliable after being put into use.

**Keywords** - Vehicle Gasohol Delivery System, Centralized Control, OMRON C200HX PLC, Communication, RS232

## I. INTRODUCTION

The fuel delivery automation control system is an important component of oil store-plant's monitoring system. Its main purpose is to achieve precise quantitative control about refined oil. Vehicle Gasohol is a clean fuel which is mixed with denatured fuel ethanol and regular gas by a certain proportion. It has many advantages such as saving energy and reducing pollution emissions.

This paper introduced the design scheme and implementation process of an accurate fuel delivery automation control system in an oil store-plant, including structure of the overall system, pipeline equipment of gasohol delivery device (Hok-bit), software process. This paper involved the speed and accuracy of the fuel delivery system, and the key will be focused on the control of the electro-hydraulic valve and programs related to communications.

## II. INTRODUCTION OF VEHICLE GASOHOL DELIVERY SYSTEM

### 1. structure of the overall system

A centralized control scheme is adopted in this system, where a C200HX series OMRON PLC works as its central controller, which will pipeline grading control the electro-hydraulic valve and oil pump-fat oil. The system works precisely and proves to be reliable after being put into use. System structure is showed in the Fig.1. The entire system which is consists of booking machine, monitoring machine, PLC and field equipment control eight Hok-bits all together. Gasohol delivery devices(Hok-bit) include a series of field equipment, terminals, electro-hydraulic valve, crane etc. The control room which is composed of business machine, monitor and PLC is the core of the control system. Its purpose is responsible for the distribution of fat, operational and monitoring.

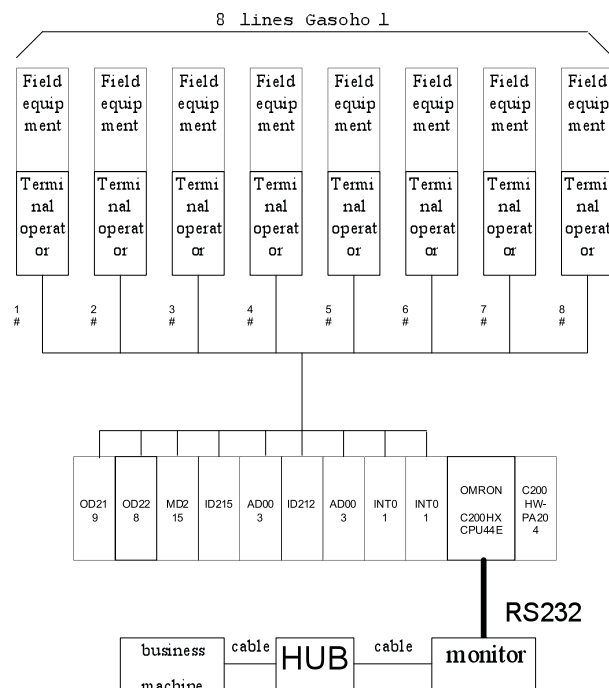

Fig.1 System structure

Business machine is mainly responsible for gasohol delivery, operating the database and issuing an appointment volume, while allocating a five password to users to operate oil. Monitor will exchange real-time date with PLC, and at the same time the information of gasohol delivery oil will be displayed on the monitor screen, and you can do operating such as input density, control gasohol delivery; it will also clear the data ,then write it back to the database timely, statistics the date etc., this process is achieved by accessing the database through the network. PLC is the core controller of all over the control system. Its major work is get the signal of field equipment, output the gasohol delivery control signal, calculation the gasohol delivery flow and terminal control operations and other functions

### 2. Process of Gasohol Delivery

Users in the business room receive a gasohol delivery paper marked with the reservation and password. Then go to the scene to choose the corresponding oil of gasohol delivery platforms, and enter the password in the terminal through the PLC the information will be sent back to monitor machine. After looking up the database, checking the password and oil correct, Monitor will download the gasohol delivery to the PLC and sent an effective password signal. PLC controllers receive this signal automatically calculate the distribution of gas and ethanol booking volume which will be shown in the terminal of

gasohol delivery, waiting for users to confirm; on the other hand, then return an information of error password. After the success of gasohol delivery appointment, we need to make electrostatic grounding and crane operation according to terminal display. Then start gasohol delivery.

Terminal Operation in the whole process of gasohol delivery can show the volume of ethanol and gas that have been issued, flow rate, temperature, marked secret, and the appointment volume. After finish gasohol delivery, the terminal shows the total gasohol delivery and prompt

on-site equipment to the digital operation.

### III. EQUIPMENTS FOR FIELDWORK

Single Hok-bit equipments diagram is shown in Fig.2. System is divided into storage areas, pump area and on-site gasohol delivery place. Gasohol delivery place devices include electro-hydraulic valves, flow meters, etc..

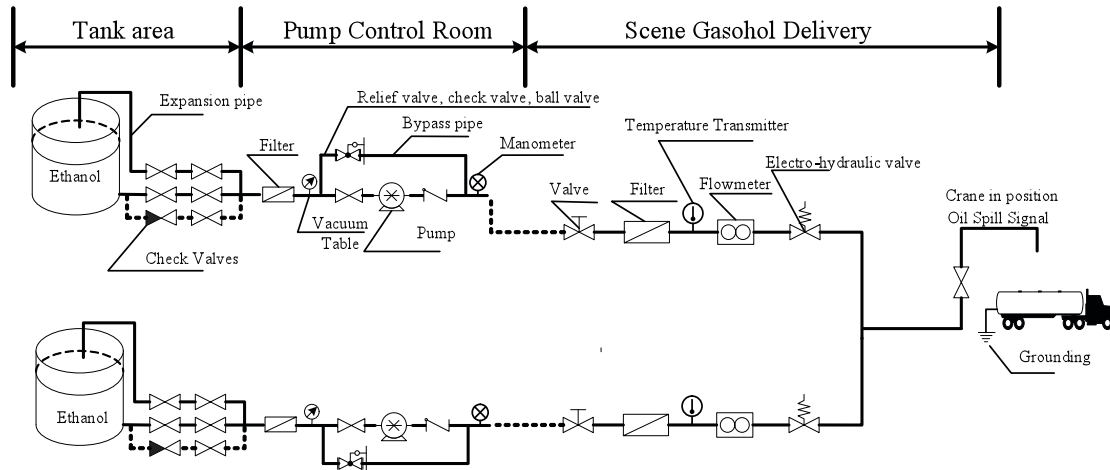

Fig.2 Single Hok-bit equipments diagram

#### 1.. Electro-hydraulic valve[1]

Site used as shown in Fig.3 FBDF Series CNC electro-hydraulic valve, which is joined by normally open solenoid valve, normally closed solenoid valve, 2 3 / 8 of small ball valves (needle valve).

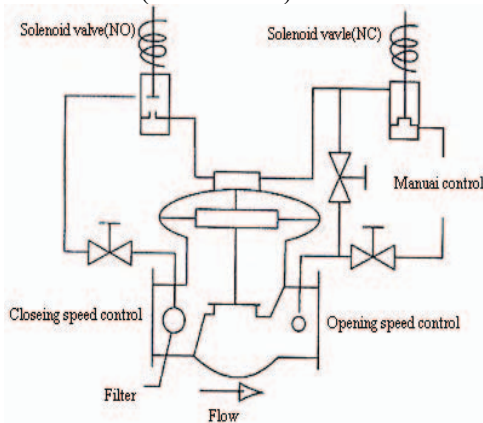

Fig.3 CNC electro-hydraulic valve structure

When the normally open and normally closed solenoid valves are powered at the same time, the diaphragm chamber where upstream toward the main valve on the channel is closed, the channel from the main valve diaphragm chamber leading to the downstream is connected. Pressure in the Lower of the diaphragm greater than the upper's , and the main valve is opened. Similarly, when the normally open and normally closed solenoid valve are closed at the same time, the main valve is closed. If the normally opening solenoid valve power, normally closing solenoid valve power, the main valve to maintain a constant export sending traffic. In addition, there is also

equipped with two small ball valves as the main valve in response in the control loop. According to the viscosity of media and the pressure of the actual pipeline, Micro-regulate the opening and closing of the main valve through regulating respectively the opening of two small ball valves.

#### 2. Flowmeter

FRA Series Roots Flowmeter is a high precision positive displacement flowmeters. It can show accumulated flow in situ, equipped with photoelectric flow converters and intelligent traffic control device which can realize remote measurement and control. This system use 100mm DN flowmeter, and Pulse equivalent is 0.1L/P. The flowmeter pulse will amplify the flow and divide frequency through the circuit where will lead the signal connected to the PLC's interruption (INT) module, in the interruption of proceedings, add the number of pulses, and can calculate velocity real-time during the process. The system works precisely after being tested.

### IV. PLC

#### 1. PLC Hardware [2]

OMRON C200HX is a medium-sized programmable controller. It is popular because its compact structure, good scalability, high-disturbance-rejection performance, and powerful integrated instruction. We can construct different sizes and meet the different needs of the controller, through different CPU and optional modules. This system use CPU44-E which has31.2KProgram memory and 6K date memory. The minimum processing time is 0.15us. General it can be configured two expansion

racks which can get close to 880 points. Besides, the expansion module this system has include high-density output modules OD219(64point) /OD218(32point)、high-density output modules OD215(32point)/OD212(16point)、two analog input modules AD003(8point)、two interrupt input module INT(8point)、and process terminal keyboard and a mixture of input/output module MD215(dynamic 128-point scan). Single control point is shown in table 1.

Table1 I/O Address Assign Table(Only single system)

input address distribution		output address distribution	
address	purpose	address	purpose
100	keyboard input	13	LCD
111	gas temperature	32.00	terminal power
131	ethanol temperature	30.00	petrol normally open valve
140.00	static grounding	30.08	ethanol normally open valve
140.08	gas over the nether lands	31.00	petrol normally closed valve
150.08	ethanol	31.08	ethanol normally closed valve
141.00	crane	33.00	Powered pump
6.00	oil spill	33.08	ethanol powered pump
8.01	petrol pulse	35.00	Terminal buzzer
9.01	Ethanol pulse		

2. PLC software [3]

PLC use CXP-V5.0 for ladder programming. There are two types of mode-offline and online. PLC which is connected to the monitor operate database during online work. Offline gasohol delivery mode can avoid be affected by monitor. Operator direct input the appointment volume of oil in the terminals through the terminal after PLC is placed in offline mode. The main program flow chart is shown in Fig.4. In addition, program also includes digital input terminal keyboard sub-process, terminal feature query sub-process, terminal LCD process.

V. CONTROL STRATEGY

Electro-hydraulic valve is the most important part in the whole control system which Concerns the fast and accuracy of the system. Considering the mixture rate of ethanol and gas ratio is about 1:9, the control of Ethanol gas hybrid oil involves two independent pipeline configuration. According to the actual volume of gasohol delivery, the gas loop use 11KW pump, the oil pipeline pump (DN100 pipelines) and electro-hydraulic valve. But ethanol loop use 3KW pump, the oil pipeline pump (DN50 pipelines) and electro-hydraulic valve. After field testing, gas pipeline can achieve 1500L/min, ethanol pipeline achieve 250L/min, through the electro-hydraulic control valve opening. We can finish gas and ethanol at the same time after adjusting actual parameters, so it can be full mixed in tank.

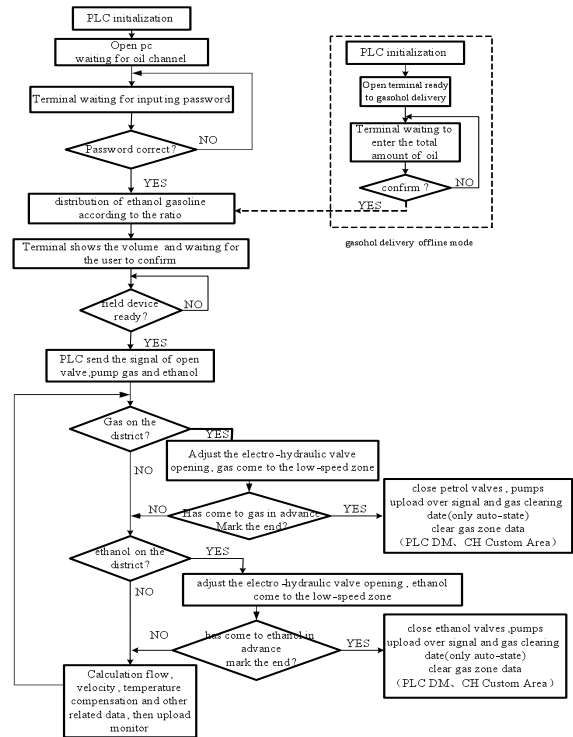

Fig.4 The main program flow chart

FBDF Series CNC electro-hydraulic valve support the multi-level-off valves. After surveying the scene, analysis and debugging, the program open a petrol pipeline valve one time and close it for many times and ethanol loop use one time open and one time close control strategy.

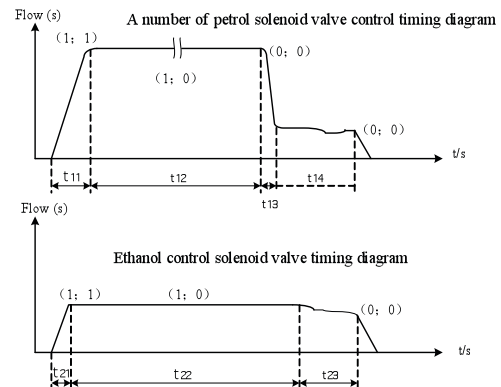

Fig.5 Actual curve of the gas delivery control

Shown in Fig.5, (n; m) represent that the case of the valve in a certain range of solenoid, in which n = 1 represent normally open solenoid valve is powered, and m = 1 represent normally closed solenoid valve is powered. On the contrary it said power outages. T11 is opening the stage of petrol valve. By setting the size of t11 can control the speed in high gas delivery area. T12 is the stage of high-speed gas delivery, and the main valve remains opening unchanged. The beginning of the T13 is reserved low-speed zone which is system settings. Usually when a few hundred is left in the system, then reduce the main valve opening and gas delivery at a low speed. According to the actual scene, we can design 2 or even 3 times closing valve in the process, this will not only guarantee that will not lead to too much error because of the inertia

of gas delivery, at the same time, reasonable regulation of time parameters and valve clearance processes can eliminate effectively "water hammer" phenomenon. In the Low speed stage of t14, electro-hydraulic valve is controlled by connected normally opening with normally closing. This will control the flow in a speed range. While according to the operating conditions in scene, system will set a empirical parameters in advance and further reduce the effects of inertia pipeline to ensure the accuracy of hair oil. Ethanol loop is similar with gas loop, because the system use DN50 Pipeline which has no water hammer phenomenon, and velocity in the pipeline around 250L/min. So close valve directly also can guarantee the accuracy of gas delivery, therefore, the ethanol control loop is much simpler than gas loop. The difference is that the former reduce the process of entering the reserved area. But after entering the reserved area, the electro-hydraulic valve normally opening, normally closing are linked that control the flow in a certain range.

In the whole process of gasohol delivery, PLC will continue to scan the scene, calculating the pulse, and a communicating with host computer. PLC will send the scene state and password, the volume of oil to PC through 232, then waiting PC write into the database sending back a valid/invalid password information and billing information. The terminal operation can go to the next step.

The system is fully able to meet the requirements of the scene after a period of test operation. Under normal circumstances, the error is only in the positive and negative deviations from 2 to 3 liters or less, and the deviation of oil has nothing to do with the volume of gasohol delivery (the volume of gasohol delivery is about 8000 ~ 30000 L).

VI. COMMUNICATIONS SCHEME FOR SURVEILLANCE COMPUTER [2][4][5]

OMRON C200HX serious PLC has a RS-232 port and a peripheral port to support and programming equipment (LSS or SSS) for communication, and communicate with personal computer Host link (PC link) or other external devices without communication protocol, and achieve 1:1 communication with other PLC; and communicate with programmable terminals link with NT interface. In addition, it can be extended communication plate.

This system use Host link communication with RS-232 interface. This communication is used to transmit data between PLC and the host computer which can make the PC link use PLC command to monitor the operational status and data content areas. We also can use the trapezoidal procedure TXD instructions to transmit the data in IOM (IR area、SR area、LR area、HR area、DM area DM0000~DM6134 etc.) of PC to PC link. The frame is data or data exchanged between PLC and PC link. It has no more than 131 characters. If not, it would take a sub-way that you can see the relevant manual [2].

Surveillance computer software use VB to programme.

Because the PLC return a code after accepting PC command and which PC buffer received actually is non-fixed-length data. The system uses a serial communication Mscmm controller and timer cycle to read data in buffer and analyse the processing; When PC link send commands to PLC and write into data through output command, instructions required to be issued according to Host link communication packaged format. And waiting for the returning code [2].

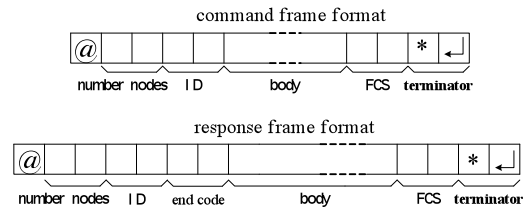

Fig.6 Command frame and response frame format

Table2 Communication Information Sheet

Communications	Communication interval	Priority
gasoline channel status	send every 6 seconds	1
gasoline channel flow	end every 2.5 seconds	3
temperature	send every 10 seconds	6
velocity	send every 4 seconds	5
ethanol channel status	send every 6.5 seconds	2
ethanol-channel flow	send every 3 seconds	4
password to channel	Transmission after terminal confirm password	
settlement amount	Send gasohol delivery, channel No.	
cancel reservation	terminal cancel an appointed return channel No.	

Command frame and the return code format are shown in Fig.6. Among them, @ is the start address, occupying a byte; 2 bytes of the data area is set default value 00 in DM6648 PLC which is used in 1: n communication to sign different PLCs; two bytes ID are used to sign the written instructions; district is the content of the body; FCS is the frame check sequence code; \* + carriage return (chr \$ (13)) is the sign of the end of the trip command. Frame code in the end is return the situation of the PLC response to host computer orders.

During communication procedures, the data transmitted from PLC to PC link is achieved through LR in relay. Communication information is shown in table 2. Procedures set a number of timers for each traffic. Status information in the various channel are sent to a unified LR0 ~ LR16 during the timer is set, while the corresponding bit is set to 1. If at this point there is only one information, we can sent this using frame format in Fig.6 to buffer in PC link, waiting for process.(one word in PLC is composed of four bytes, so actual word which

TXD instruction is send is 17 \* 4 together with the beginning of the end is 77 bytes, which is less than 131). PC link prepare a command frame and then return a signal of success after received information, then cleared PLC, waiting for the next communications. Notice that after PC link write back data into the PLC, PLC will automatically return a 11 bits yard. During the process, we need to distinguish return code form information of 77 bytes in TXD instructions. Only after reading the return code information from PLC, host computer can continue to write down the number otherwise reported communication failure.

In order to avoid some data loss or communications failures caused by uncertainties because, the process set up a communications priority(see Table 2). If because of some uncertain factors, the sub-priority has not been transmitted (communication still is 1) and at this time the high-priority come, the system will send high-priority to host computer, and then carry out sub-priority transmission. Taking into account the actual process situation, enter a password, billing and cancellation of an appointment this three situations of communication are the highest priority. If the host computer as a lost a few did not respond to these three situations, the PLC will continue to upload this data, so the design can greatly improve system accuracy and stability of communications.

## VII. CONCLUSION

The structure of ethanol gasoline delivery control system is said in this paper based on PLC, and we introduce ethanol gasoline pipeline equipment and the PLC program flow. We stress on Electro-hydraulic valve control which is the core of the entire system, and involve the Speed and accuracy of gasoline delivery system. In addition, the system focuses on the communication between the surveillance computer and PLC.

After a long period of operation, the system is able to meet the field requirements. It will not only be able to monitor

all types of information, but also can control a number of site, and issue statements such as gasoline delivery. The error of gasoline delivery volume in a day is only about plus or minus 35 liters which save resources greatly.

The system uses a centralized design. Compared to distributed control, this system has a simple control, and the interference from environmental is little, but also increased the risk. Also need to point out that electro-hydraulic valve made by domestic is the the mainstream equipment currently used in oil system, but due to its own defects, it is not very satisfactory when we control more than 100mm diameter pipes. And the electro-hydraulic piston valve has more advantageous.

## ACKNOWLEDGMENT

The authors would like to acknowledge Mr Tong Rui, Zhang Jian from Tianjin University for their initial work, technical discussions and timely help.

## REFERENCES

- [1] FBDF(DYF)SERIES series CNC electro-hydraulic valve use and maintenance(www.wxuda.cn.)
- [2] OMRON Programmable Controllers C200HX/ C200HG/ C200HE OPERATION MANUAL, 2004. (www.fa.omron.com.cn.)
- [3] SYSMAC WS02-CXPC1-E-V50 CX-Programmer Ver.5.0 OPERATION MANUAL, 2004. (www.fa.omron.com.cn.)
- [4] SYSMAC WAY Host Link Units For Use With C-series Rack PCs, 1996. (www.fa.omron.com.cn.)
- [5] Fanyizhi, Chenliyuan. Visual Basic and RS-232 serial communication control. Beijing: Tsinghua University Press.