

Research on Control Strategy for Three-Phase PWM Voltage Source Rectifier

Yu WANG¹ Yanbo CHE¹ K.W.E CHENG²

¹ School of Electrical Engineering & Automation, Tianjin University, Tianjin China.

E-mail: ybche@tju.edu.cn

² Department of Electrical Engineering, The Hong Kong Polytechnic University, Hong Kong,

E-mail: eecheng@polyu.edu.hk

Abstract –This paper first introduces the topology of Three-Phase PWM Voltage Source Rectifier (VSR). Then the mathematical models in three-phase static and two-phase rotary coordinate system are built. Based on that theory and the voltage-oriented vector control's idea, the paper introduces a dual-channel closed-loop control strategy with current-inner-loop and voltage-outer-loop. Active power channel is aim to make DC side voltage remain steady, and reactive power channel can regulate power factor by set current q-axis component reference. In order to prove that voltage-outer-loop is necessary, the paper builds a comparative model without a voltage loop. According to change current q-axis component reference value, illuminate reactive power channel's effect. In MATLAB/SIMULINK, the paper sets up simulation models for above cases. The simulation results show that the voltage-outer-loop is essential, and prove that current q-axis component can regulate power factor. The Three-Phase PWM Voltage Source Rectifier dual-channel double-closed-loop control strategy is effect.

Keywords - Three-Phase PWM Voltage Source Rectifier, voltage-oriented; dual-channel closed-loop control, voltage-outer-loop, current q-axis component.

I. INTRODUCTION

Conventional rectifying method adopts phase-control method or passive diode rectifier. They have has some disadvantages, including slower dynamic respond, passive diode rectifier can absorb harmonic current from power grid and the DC-side energy can not feed back to power grid[1]. Three-Phase PWM Voltage Source Rectifier (VSR) applies Pulse Width Modulation (PWM) technology, it can overcome the phase-control method and passive diode rectifier's drawbacks, and has higher power factor, lower harmonic current and rapid dynamic respond, so Three-Phase PWM Voltage Source Rectifier is a developing rectifying method [2].

Three-Phase PWM voltage source Rectifier is applied in normal and large power converter field, it also can be used in large UPS supply system, in order to achieve unit power factor and eliminate harmonic current. It is a new important focus in power quality field [3]. This paper will study the control strategy for VSR in particular, and prove the control performance in MATLAB/SIMULINK.

II. THE BASIC THEROY FOR VSR

A. Topology for VSR

The main circuit topology is showed in Fig.1. AC-side inputs are ideal three-phase symmetrical voltage source, which are filtered by resistance R and inductor L, then

connected to three-phase rectifier consist of IGBT and diode. The output load is composed of capacitance and resistance. Suppose that the power switch is ideal, its fundamental wave equivalent circuit is showed in Fig.2. The input side for PWM rectifier can be equaled to three ideal symmetrical voltage sources, and the output side can be replaced by three ideal current sources [4].

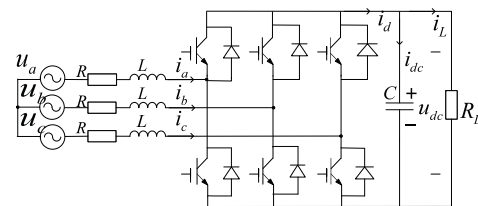

Fig.1. VSR circuit topology

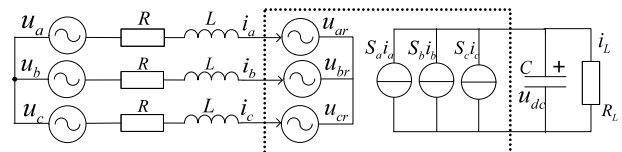

Fig.2. VSR fundamental wave equivalent circuit

B. Mathematical Models for VSR

Base on the topology and equivalent circuit for VSR, we can get (1).

$$\begin{cases} u_a - i_a R - L \frac{di_a}{dt} - S_a u_{dc} \\ = u_b - i_b R - L \frac{di_b}{dt} - S_b u_{dc} \\ = u_c - i_c R - L \frac{di_c}{dt} - S_c u_{dc} \\ C \frac{du_{dc}}{dt} = i_d - i_L = S_a i_a + S_b i_b + S_c i_c - i_L \end{cases} \quad (1)$$

Where: S_a, S_b, S_c are switch functions, when $S_k = 1$, equals the up-arm switch is closed, and the down-arm switch is open. When $S_k = 0$, equals an opposite result (where $k = a, b, c$). It is three-phase three-wire system, so we can get (2).

$$\begin{cases} i_a + i_b + i_c = 0 \\ u_a + u_b + u_c = 0 \end{cases} \quad (2)$$

Linking (2) into (1) is (3):

$$\begin{cases} L \frac{di_a}{dt} = u_a - R i_a - \left(S_a - \frac{S_a + S_b + S_c}{3} \right) u_{dc} \\ L \frac{di_b}{dt} = u_b - R i_b - \left(S_b - \frac{S_a + S_b + S_c}{3} \right) u_{dc} \\ L \frac{di_c}{dt} = u_c - R i_c - \left(S_c - \frac{S_a + S_b + S_c}{3} \right) u_{dc} \\ C \frac{du_{dc}}{dt} = S_a i_a + S_b i_b + S_c i_c - i_L \end{cases} \quad (3)$$

The active component i_d^* and the reactive component i_q^* are compared with their feedback values, then the error are calculated by current PI regulator, the output values are the voltage component u_d^*, u_q^* . According to (10), u_d^*, u_q^* add $\omega_1 L i_q, -\omega_1 L i_d$ and power grid voltage disturb compensation u_s , the result are command control signal u_d^*, u_q^* , which can generate the necessary signals for controlling the switch order of VSR [9]. The whole control structure is showed in Fig.3.

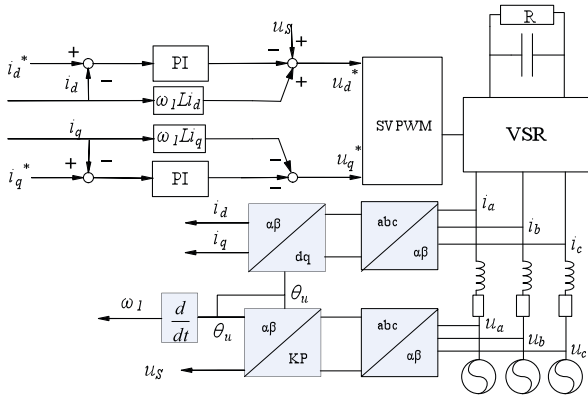

Fig.4 VSR single-closed-loop control structure

C. The Single-Closed-loop Control Model

In order to prove the effect of voltage-outer-loop for dual-closed-loop control model, the primary model is changed to single-closed-loop model,

which remains dual-channel structure. The DC-voltage-loop is removed in new model's active power channel, current d-axis component command value i_d^* is given, and reactive power channel is the same as former. In MATLAB/SIMULINK, the simulation model will be built to prove the single-closed-loop model's control performance. Its structure is showed as Fig.4.

To prove the effect of reactive power channel, the current q-axis component command value i_q^* can be regulated. In MATLAB/SIMULINK, we can see how i_q^* affects the power factor.

IV. SIMULATION

A. Simulation Model.

In MATLAB/SIMULINK, the dual-closed-loop model and single-closed-loop model are built respectively. Simulation time is 0.3s. The model's parameter is set as follows: power grid phase voltage's RMS is 110V, $L=5mH, R=5\Omega, C=2.2mF, i_L=20A, u_{dc}^*=300V$. Dual-closed-loop model is showed in Fig.5; its inner-current-loop model is showed in Fig.6.

Single-closed-loop model is showed in Fig.7, the current command value is set as follows: $i_d^*=30A, i_q^*=0A$. Its inner-loop parameter is as same as dual-loop model.

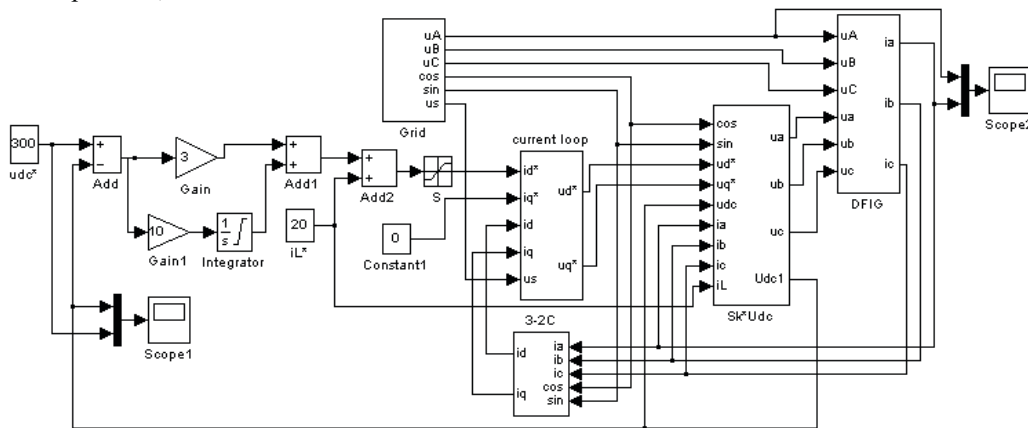

Fig.5 VSR dual-closed-loop simulation model

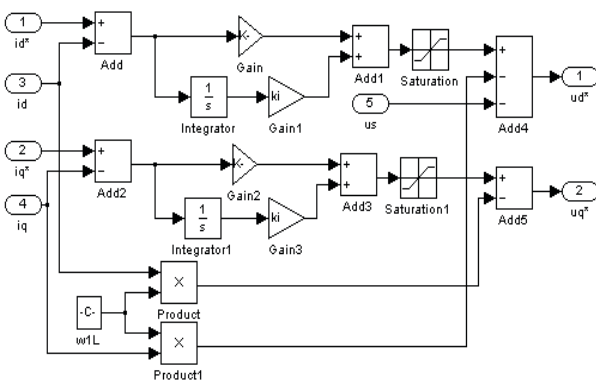

Fig.6 VSR inner-loop simulation model

B. Simulation Result

1) When $i_q^*=0A$, dual-loop simulation results are showed in Fig.8-9. Fig.8 is the DC-side voltage simulation result; Fig.9 is one phase simulation result for power grid voltage and input current. From Fig.8, u_{dc} can follow the command

signal u_{dc}^* , which proves that the VSR DC-side voltage can be controlled as constant steadily. From Fig.9, the result show that input grid voltage and input current have same phase, which illuminates that the dual-closed-loop model can make system run in unit power factor.

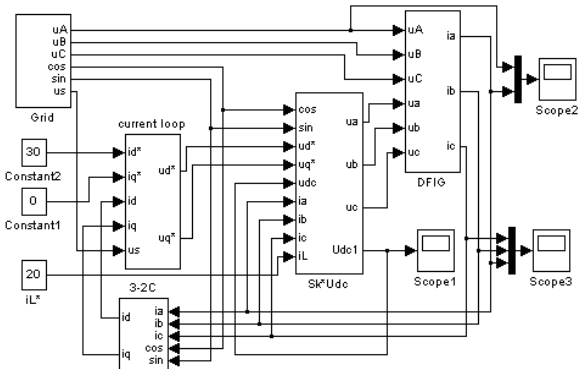

Fig.7 single-closed-loop simulation model

2) when $i_q^* = 20A$, dual-loop simulation results are showed in Fig.10-11. Fig.10 is the DC-side voltage simulation result; Fig.11 is one phase simulation result for power grid voltage and input current. Compared with Fig.8-9, the result shows that u_{dc} also can follow the command signal u_{dc}^* , which is similar to Fig.8. From fig.11, we can see that the phase of input voltage leads the phase of current, and the power factor is not equal to unit. It proves the i_q^* affects the power factor indirectly.

3) The single-closed-loop simulation results are showed in Fig.12-13. Fig.12 is the DC-side voltage simulation result; Fig.13 is one phase simulation result for power grid voltage and input current. The simulation results show that u_{dc} can't follow the command signal u_{dc}^* , its value can't be controlled to be steady. Current wave has high harmonic, its performance can't satisfy control demand, which proves that the DC-voltage-loop is necessary.

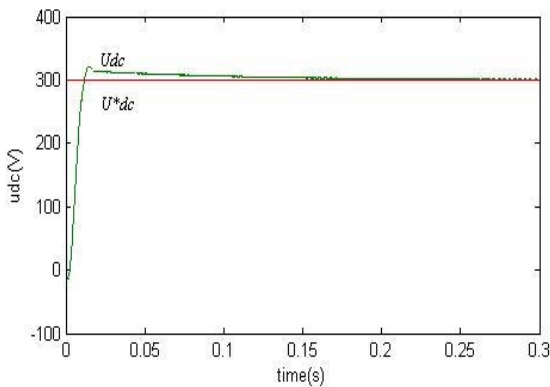

Fig.8 dual-loop u_{dc} simulation result ($i_q^* = 0A$)

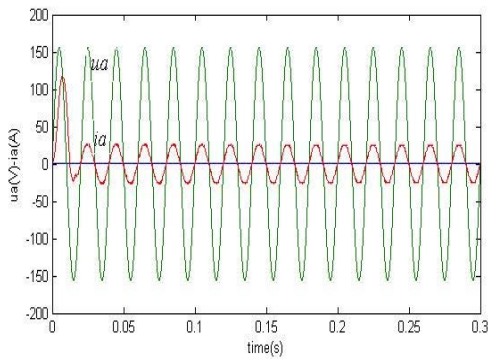

Fig.9 dual-loop u_a, i_a simulation result ($i_q^* = 0A$)

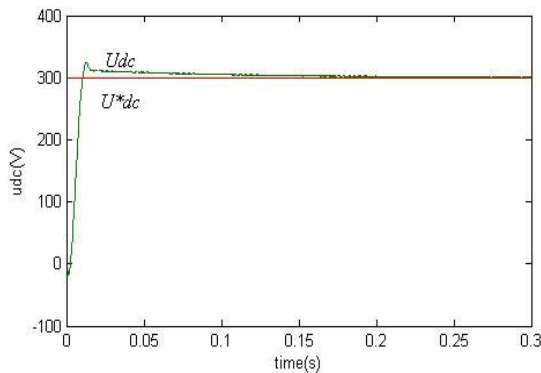

Fig.10 dual-loop u_{dc} simulation result ($i_q^* = 20A$)

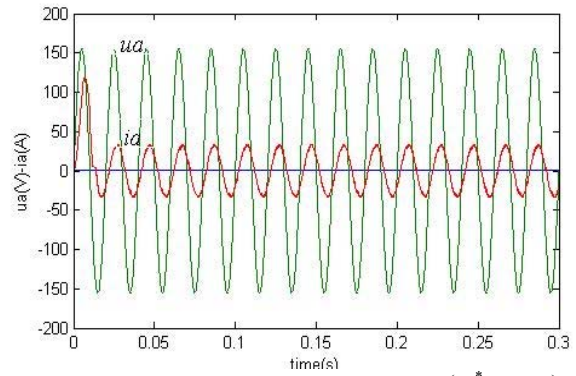

Fig.11 dual-loop u_a, i_a simulation result ($i_q^* = 20A$)

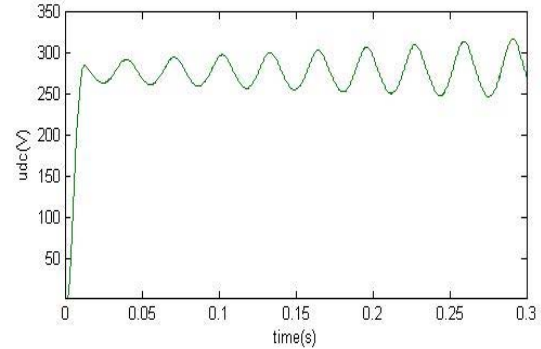

Fig.12 single-loop u_{dc} simulation result

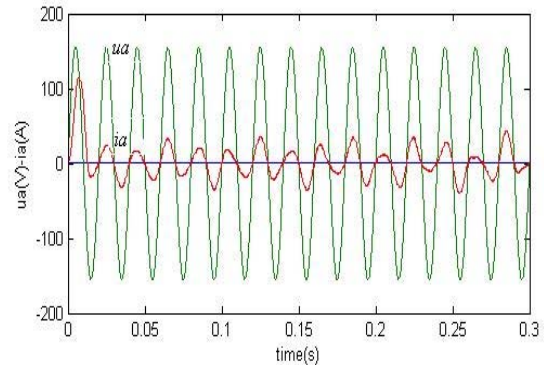

Fig.9 single-loop u_a, i_a simulation result

V. CONCLUSION

The simulation results show that the dual-channel closed-loop strategy has good control effect. Active power channel can control DC-side voltage to be constant for VSR. In reactive power channel, the power factor can be changed by regulating i_q^* . To make system run in unit power factor, we can set $i_q^* = 0$. Compared with dual-closed-loop model, the simulation results of single-loop model is not ideal. Without DC-voltage-loop, u_{dc} can't be steady, which shows that DC-voltage-loop is essential in active power channel. According to compare the simulation results, it proves that the dual-channel closed-loop control strategy for Three-Phase PWM Voltage Source Rectifier is correct.

ACKNOWLEDGMENT

This work is supported by Youth Foundation Project of National Natural Science Foundation Committee "Distributed Generation System Simulation and Optimization Control" (NO.50625722); National Key

Foundational Research Project (973) “Distributed Generation Supply System Pertinent Foundational Research” (NO.2009CB219700), and National Natural Science Foundation Key Project “Key Technique Research of Distributed Generation Micro-Grid System Control and Protection” (NO. 50837001).

REFERENCES

- [1] Kataoka, T.; Fuse, Y.; Nakajima, D.; Nishikata, S.; A three-phase voltage-type PWM rectifier with the function of an active power filter. Power Electronics and Variable Speed Drives, 2000. Eighth International Conference on (IEE Conf. Publ. No. 475)18-19 Sept. 2000 Page(s):386 – 391.
- [2] E. Wernekinck, A. Kawamura, and R. Hoft, “A high frequency AC/DC converter with unity power factor and minimum harmonic distortion,” *IEEE Trans. Power Electron.*, vol. 6, pp. 364–370, May 1991.
- [3] F. Blaabjerg and J. K. Pedersen, “Single current sensor technique in the DC-link of three-phase PWM-VS inverters a review and the ultimate solution,” in *Proc. IAS’96*, 1996, pp. 1192–1202.
- [4] Rusong Wu, Shashi B. Dewan, Gordon R.Slemon. A PWM AC-to-DC Converter with Fixed Switching Frequency. *IEEE Trans. Ind. App* 1,1990,26 (4):880-885
- [5] Dixon J W · Boon-Teck Ooi · Indirect current control of a unity power factor sinusoidal current boost type three-phase rectifier[J] · *IEEE Trans on Industrial Electronics* · 1988 · 35(4) : 508—515 ·
- [6] Verdelho, P. Marques, G., “Bi-directional AC-DC power converter with independent reactive power control”, *SPPEDAM*, 1994, pp.49-84.
- [7] Kolar, J. W. and Zach, F.C.: A Novel Three-Phase Utility Interface Minimizing Line Current Harmonics of High-Power Telecommunications Rectifier Modules. Proceedings of the 16th IEEE International
- [8] Holmes D.G. and Lipo T.A.: Pulse Width Modulation for Power Converters: Principles and Practice, Hoboken, NJ: John Wiley, 2003
- [9] C.-T. Pan and J.-J. Shieh, “New space-vector control strategies for three-phase step-up/down AC/DC converter,” *IEEE Trans. on Industrial Electronics*, vol. 47, pp. 25 – 35, February 2000.