

# Development of a Commercial Induction Cooker

Y. LU<sup>1</sup> K. W. E. CHENG<sup>1</sup> K. W. CHAN<sup>1</sup> Z. G. SUN<sup>1</sup> S. W. ZHAO<sup>1</sup>

<sup>1</sup>Department of Electrical Engineering, The Hong Kong Polytechnic University, Hong Kong  
E-mail: eeyanlu@polyu.edu.hk

**Abstract**—This paper presents the configuration of a prototype induction cooker. Effective control scheme is incorporated in the voltage-fed H-bridge series resonant converter, which is based on an auto-frequency tracking strategy. The proposed control strategy ensures stable operation characteristics of overall converter system and ZVS (Zero Voltage Switching) operation as well as power regulation. The operation principle and the proposed control scheme are described. Also, the experimental results and the performance characteristics are shown for a prototype induction cooking system rated at 15kW.

**Keywords**—Resonant converter, induction cooking, coil, phase angle, frequency tracking

## I. INTRODUCTION

With remarkable advancements of power semiconductor devices and electronic control systems, much attention has been focused on the research and developments of high-frequency resonant converters capable of supplying high-power to induction heating loads. Power switching components such as MOSFETs and IGBTs, are used in high frequency resonant inverters to reduced overall size and switching losses can be reduced as well by means of soft-switching technique. The induction cooking is one of the many applications for induction heating using high-frequency resonant converters. Compared with traditional gas cooking woks, induction cooking woks have the advantages of cleanness, high heating efficiency, lower noise and high power density. Environmental high power induction cookers are more potential in commercial cooking markets. A 15kW Induction cooker is introduced in this paper. An effective control scheme incorporated in the voltage-fed H-bridge series resonant converter for induction heating applications is presented, which is based upon auto-frequency tracking strategy. The proposed control scheme can ensure reliability of overall converter system and operation under the principle of ZVS (Zero Voltage Switching) in spite of power regulation process as well as load fluctuations. Output power regulation is based upon phase angle control through PFM (Pulse Frequency Modulation). Furthermore, the operation principle is described and its performance characteristics are verified by the experimental results for a prototype induction cooking system rated at 15kW.

## II. SYSTEM DESCRIPTION

Fig. 1 shows the diagram of the converter. The DC voltage which is around 500V, is from output of a three phase rectifier. IGBTs S1-S4 constructed an H-bridge with which the DC voltage is inverted to high frequency AC voltage, which is applied to the resonant tank constituted by resonant capacitor  $C_r$  and the induction coil. In addition power regulation, the converter has following characterizes:

### 1. Zero voltage switching (ZVS):

Resonant coil current ( $i_r$ ) is lagging the inverted voltage ( $v_i$ ) and each anti-parallel diode conducts prior to associated IGBT. Hence ZVS can be achieved and therefore efficiency is high.

### 2. Frequency auto-tracking:

Inductance of the coil is variable with respect to different wok material or wok position. The frequency is auto-tuned according to various inductances. At maximum power level, switching frequency is equal to the resonant frequency, which is determined by coil inductance and resonant capacitance. Reactive power is limited to be minimum level and efficiency is modified.

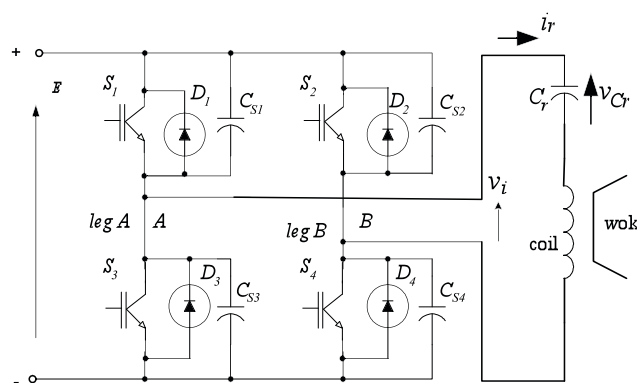

Fig. 1 Converter diagram

## III. ANALYSIS OF LOAD CHARACTERISTICS AND POWER REGULATION

The eddy current inside the wok is induced due to the magnetic flux generated from the coil. Thus the coil and the wok can be considered as a transformer connected with an equivalent resistor as shown in Fig. 2 where  $L_r$  is the leakage inductance used for resonance. The equivalent circuit of the resonant tank is shown in Fig. 3. Either the value or frequency of the voltage  $v_i$  can be adjusted by control the H-bridge converter. It is believed that frequency modulation is more reasonable because coil current is always continuous under PFM strategy and therefore ZVS is easily to be realized. In addition, the range of power regulation can be wider due to high level leakage of the coil. The resonant frequency of the tank can be expressed as

$$f_r = \frac{1}{\sqrt{L_r C_r}}$$

To achieve ZVS, switching frequency must higher than the resonant frequency. Therefore impedance of the tank is inductive. The closer is switching frequency to resonant frequency, the higher is the coil current, which generates higher output power.

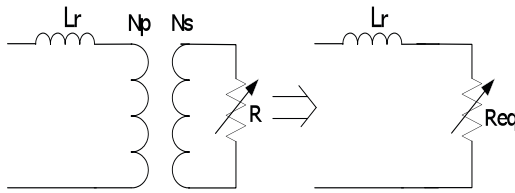

Fig. 2 Model of the coil-wok

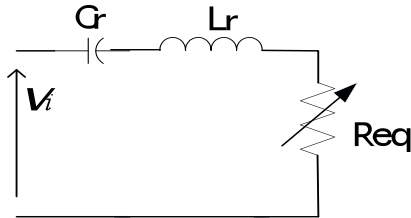

Fig. 3 Resonant tank

IV. CONTROL STRATEGY AND OPERATION

As the resonant frequency  $f_r$  is concerned with the load such as the spacing between coil and wok or the property of the used wok. To achieve maximum power transfer, Phase-locked Loop (PLL) is usually employed in induction heating to get frequency tracking. However, sometimes it is difficult to keep PLL to be stable in practice operation. The purpose of employing PLL is actually to make the inverted AC voltage is in same phase with the coil current. If the coil current is measured, the PLL can be replace with a circuit which is for detecting the zero-crossing points of the coil current. For example S1 and S4 should be switched on when the coil current is being from negative to positive. Similarly S2 and S3 should be switched on when the coil current is being from positive to negative. The coil current is initially set up by an extra circuit at start stage.

The output power is contributed by the active power of the resonant tank circuit. Hence power regulation can be achieved by control the power factor of the circuit or the phase angle between resonant coil current and resonant voltage (inverted voltage). As shown in Fig. 4, the phase-shifted coil current is leading the coil current a phase angle  $\alpha$  and it is converted to be a square waveform, which is considered as reference of bridge gate signals. Hence the phase angle is the command for power level and ZVS is achieved meanwhile. The scheme of the control system is shown in Fig. 5.

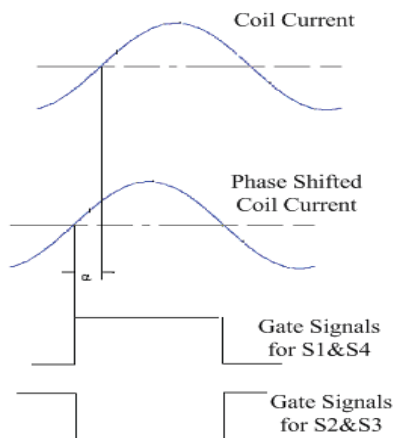

Fig. 4 Illustration of phase angle control

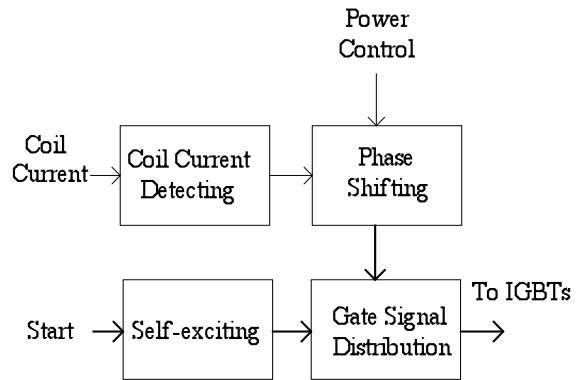

Fig. 5 Scheme of the control system

V. EXPERIMENTAL RESULTS

Experiments were carried to test the performance of the prototype induction cooker. The H-bridge resonant converter was built using SKM100GB123D as main switching devices. The spacing between cooking vessel and the heating coil was maintained 10mm thickness using thermal insulator. The system parameter is followed as;  $V=510V$ ,  $C_r=0.3\mu F$ ,  $L_r=0.25mH$ ,  $R_{eq}=13.5\Omega$ , Dead Time= $1.1\mu s$ . Fig. 6 and Fig. 7 show the coil current under low power and high power, respectively. When the induction cooker works at low power level the waveform of the coil current is close to triangle as the resonant tank is quite inductive. Q factor of the resonant tank is high due to the large leakage inductance of the coil. Hence the coil current at power level is quite sinusoidal. The capacitor should be with low ESR. Parallel connection is a better way to construct it. Effective ZVS can be illustrated in Fig. 8, which means voltage across IGBT S1 is zero before it is switched on. Eddy current is difficulty to be measured. If the active power of the resonant tank circuit is assumed to be output power, the efficiency can be over 90% when the induction cooker works at high power level. Auto-frequency tracking function can be easily verified by changing the spacing between cooking vessel and the heating coil. Switching frequency would go down automatically if the spacing decrease and vice versa.

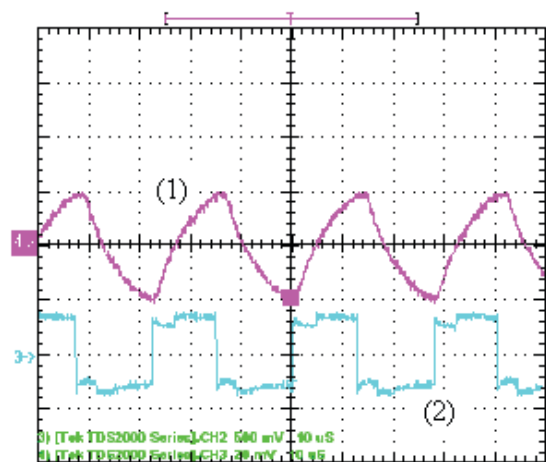

Fig. 6 Waveforms for low power (1): Coil current (2): Gate signal 10A/DIV 20V/ DIV 10us/DIV

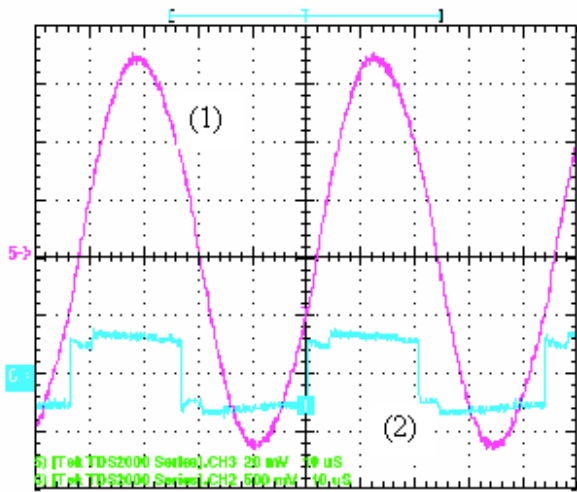

Fig. 7 Waveforms for high power (1): Coil current (2): Gate signal 20V/div 15A/DIV 10us/DIV

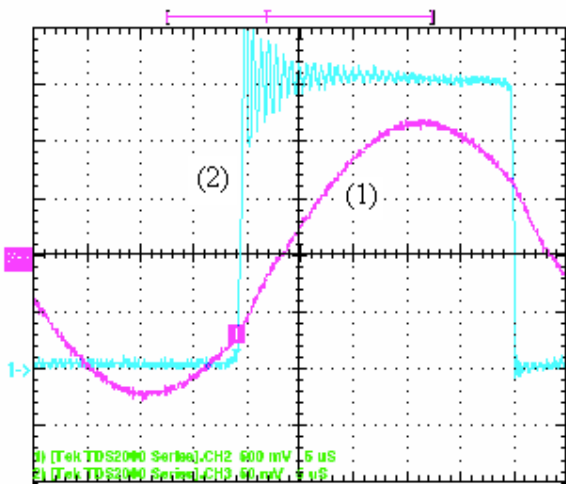
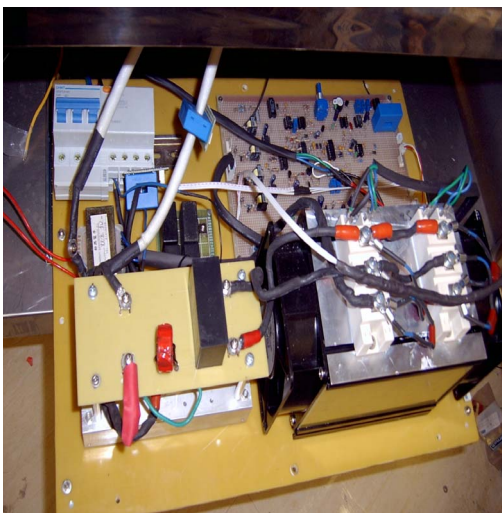

Fig. 8 Waveforms for showing ZVS (1): Coil current (2): Voltage  $V_A$  (point A) 25A/ DIV 100V/ DIV 5us/ DIV



(a)



(b)

Fig. 9 Pictures of the Induction Cooker (a) Circuit (b) Wok station

#### IV. CONCLUSION

In this paper the operation principle of the prototype induction cooker is introduced together with auto-frequency tracking, power regulation and ZVS algorithm incorporated in it. Its performance characteristics are verified by the experimental results for a prototype induction cooking system rated at 15kW. The induction cooker is designed to replace ordinary stove plates. The prototype has been developed and the performance is good. It can provide fast heating and the comparison with gas cooking, it can reduced to less than 1/3 of the power for the same amount of heating capability.

#### ACKNOWLEDGEMENT

The project is supported by RGC General Research Fund under the project reference PolyU 5133/08E (B-Q13S). The support from CLP power is appreciated.

#### REFERENCES

- [1] K.W.E. Cheng, "Classical Switched Mode and Resonant Converters", The Hong Kong Polytechnic University, 2002.
- [2] D.M. Sable, and F.C. Lee, "The operation of a full bridge, zero-voltage-switched PWM converter", Proceedings of Virginia Power Electronics Center Seminar, 1989, pp. 92-97.
- [3] N.S. Bayndtr, O. Kukrer and M. Yakup, "DSP-based PLL-controlled 50-100 kHz 20 kW high-frequency induction heating system for surface hardening and welding applications", IEE Proc-Electr. Power Appl., Vol. 150, No. 3, May 2003.
- [4] S. Furuya, T. Maruhashi, Y. Izuno, and M. Nakaoka, "Load-adaptive frequency tracking control implementation of two-phase resonant inverter for ultrasonic motor," IEEE Trans. Power Electron., vol. 7, no. 3, pp. 542-550, 1992.
- [5] Y. Mizutani, T. Suauki, H. Ikeda, H. Yoshida, and S. Shinohara, "Frequency control of MOSFET full-bridge power inverter for maximizing output power to mega-sonic transducer at 3 MHz," Pmc. Ind. Applicat. Conf, St. Louis, MO, pp. 1644-1651, 1998.