

OPTIMUM NONCOHERENT FM-DCSK DETECTOR: APPLICATION OF CHAOTIC GML DECISION RULE

Géza Kolumbán & Gábor Kis *

Department of Measurement and
Information Systems,
Budapest University of Technology and
Economics, Budapest, H-1521, Hungary.
{kolumban, kisg}@mit.bme.hu

Francis C.M. Lau & Chi K. Tse[†]

Department of Electronic and
Information Engineering,
The Hong Kong Polytechnic University,
Kowloon, Hong Kong, China.
{encmlau, encktse}@polyu.edu.hk

ABSTRACT

A new detector configuration is proposed for the detection of FM-DCSK signals with improved noise performance. Since the new detector configuration is developed directly from the chaotic GML decision rule, it offers the best noise performance in AWGN channel in the category of noncoherent detection if the reception of a single isolated symbol and memoryless modulation scheme is considered. The paper shows how the *a priori* information on chaotic signals may be exploited in waveform communication to maximize the noise performance.

1. INTRODUCTION

A lot of chaos-based communication schemes have been proposed recently [1]. Among them the frequency modulated-differential chaos shift keying (FM-DCSK) modulation scheme assures the best potential noise performance if the reception of a single isolated symbol and memoryless modulation schemes are considered, because the FM-DCSK is the only chaotic modulation scheme which has orthonormal basis functions [2].

The noise performance of a modulation scheme depends on two factors: on the separation of elements of signal set and the detector configuration. The separation of elements of signal set gives the performance bound on attainable noise performance. The better the separation, the better the attainable noise performance.

The detector observes the received signals in the observation space. A well designed detector exploits all the available *a priori* information on the elements of signal set to separate the signal to be detected from channel noise, that is, to suppress the noise. As a rule of thumb we may say,

* This research was financed by the Hungarian Scientific Foundation of Hungary (OTKA) under Grant number T-038083

[†] This work is supported by a research grant provided by Hong Kong Polytechnic University.

the more *a priori* information is exploited, the better noise performance is achieved. In this respect the key issue is the decision rule: the application of maximum likelihood (ML) decision rule assumes that all elements of signal set are *exactly* known at the receiver, while in case of the generalized maximum likelihood (GML) decision rule [3] only certain parameters of elements of signal set must be known.

In chaotic waveform communication, the elements of signal set are not fixed waveforms. The chaotic basis functions are different for each transmitted symbol even if the same symbol is transmitted repeatedly. The continuously varying waveforms make it very hard to find a mathematical model for the detection problem that is simple enough.

This problem has been solved in [4], where the Fourier analyzer concept was introduced to define the observation space of the detector. Section 2 surveys the Fourier analyzer concept and introduces the chaotic GML decision rule. The importance of chaotic GML decision rule is that it shows what is the main theoretical difference between chaotic and conventional waveform communication and how the maximum amount of *a priori* information may be exploited in chaotic communication by the detector.

The new detector configuration is developed in Sec. 3 from the chaotic GML decision rule. Since the application of GML decision rule results in optimum noise performance in additive white Gaussian noise (AWGN) channel, this detector configuration gives the theoretical limit on bit error rate (BER) that may be achieved with chaotic modulation schemes if chaotic basis functions may not be recovered at the receiver from the modulated, distorted and noisy received signal.

Section 4 shows the noise performance of the optimum noncoherent FM-DCSK detector that has been determined by computer simulation. The results are compared with the noise performance of classical FM-DCSK and conventional FSK detectors, conclusions are drawn and the limit on attainable performance improvement is discussed.

2. GENERALIZED MODEL OF WAVEFORM COMMUNICATIONS

Each digital receiver must contain at least a channel filter, whose bandwidth is equal to the bandwidth of modulated signal, and a decision circuit. Consequently, the minimum amount of *a priori* information that is always available at a receiver is the RF bandwidth $2B$ of channel filter and symbol duration T .

Let $r_m(t) = s_m(t) + n(t)$ denote the received signal, where $s(t)$ denotes the transmitted element of signal set and $n(t)$ represents the channel noise. This signal is fed into the channel filter, the output of channel filter is denoted by $\tilde{r}_m(t)$. This signal is observed by the detector.

2.1. The Fourier Analyzer Concept

Each element $s_m(t)$ of signal set is expressed as a linear combination of N orthonormal basis functions $g_j(t)$, $j = 1, 2, \dots, N$ [2]. The Fourier analyzer concept [4] has been derived from the recognition that a detector observes the received signal only on the interval $0 \leq t \leq T$ to perform the detection. Consequently, the signal may have any value outside this interval. Let us exploit this property and let a periodic basis function be defined as

$$g_{T,j}(t) = \begin{cases} g_j(t), & \text{for } 0 \leq t \leq T \\ g_j(t - CT), & \text{otherwise} \end{cases}$$

where C is an arbitrarily nonzero integer. Then the basis functions may be represented over the interval $0 \leq t \leq T$ by a Fourier series

$$g_{T,j}(t) = \sum_{k=K_1}^{K_2} \left[\alpha_{j,k} \cos(k \frac{2\pi}{T} t) + \beta_{j,k} \sin(k \frac{2\pi}{T} t) \right] \quad (1)$$

where $\alpha_{j,k}$ and $\beta_{j,k}$ denote the coefficients of Fourier series expansion. The constants K_1 and K_2 are determined by the frequency band covered by the spectrum of basis functions $g_j(t)$, for a band-pass system $K_2 - K_1 + 1 = 2BT$.

Equation (1) shows that the basis functions have a discrete spectra, the fundamental frequency is determined by the bit duration, and that the number of harmonically related frequencies to be considered is determined by $2BT$.

The Fourier series expansion defines the observation space which is a Hilbert space of harmonically related $\cos(\cdot)$ and $\sin(\cdot)$ functions with dimension $\hat{D} = 4BT$. Note that the dimension of observation space is determined by those parameters that are always known at the receiver.

2.2. Chaotic GML Decision Rule

Two orthonormal basis functions are used in FM-DCSK and each bit is mapped into one basis function. This paper assumes that identical chaotic synchronization may not be used due to the bad propagation conditions. If so then

the GML decision rule [3] has to be used. The application of GML decision rule is summarized in the following.

Consider the observation space constructed by the Fourier analyzer concept. Each basis function defines a subspace in the observation space. The received signal is projected into the subspaces of each basis function and the energies measured in the different subspaces are determined. The decision is made in favor of the subspace and, consequently, in favor of the bit, that receives the greatest energy.

But the GML decision rule known from the theory of conventional communication systems may not be applied directly to chaotic communication, since in the latter the basis functions vary from symbol to symbol. Consequently, only the mean values of the Fourier coefficients may be determined in (1).

Let a weight be defined for each harmonic frequency in (1) as

$$W_{j,k} = \frac{E \left[\sqrt{\alpha_{j,k}^2 + \beta_{j,k}^2} \right]}{E \left[\sqrt{\alpha_{j,k_0}^2 + \beta_{j,k_0}^2} \right]}$$

where $k_0 = (K_1 + K_2)/2$ assigns the center frequency of FM-DCSK signal and E denotes the expectation operator. Then the weighted energy received in the subspace of $g_j(t)$ is obtained as

$$E_{j,m} = \frac{2}{T} \sum_{k=K_1}^{K_2} \left(\left[W_{j,k} \int_0^T \tilde{r}_m(t) \cos(k \frac{2\pi}{T} t) dt \right]^2 + \left[W_{j,k} \int_0^T \tilde{r}_m(t) \sin(k \frac{2\pi}{T} t) dt \right]^2 \right). \quad (2)$$

Due to channel noise, $E_{j,m}$ is a random variable. Since the spectra of basis functions are not uniform, the signal-to-noise-ratio (SNR) differs for each terms in (2). The duty of the weights $W_{j,k}$ is to maximize the SNR for each basis function represented by Fourier series in the observation space. As a result, the overall SNR is maximized and the best noise performance is achieved. This decision procedure is called chaotic GML decision rule.

The weights $0 \leq W_{j,k} \leq 1$ are determined from the averaged spectrum of the j th basis function.

3. DEVELOPMENT OF NEW FM-DCSK DETECTOR CONFIGURATION

This section develops the block diagram of an optimum noncoherent FM-DCSK detector from (2). To do that, first the weights $W_{j,k}$ have to be determined.

3.1. Determination of Weights

Equation (1) gives the Fourier series expansion of basis functions. Recall that bits "1" and "0" are mapped into the

first and second basis functions, respectively. It has been shown in [5] that the spectra of first and second basis functions have only even and odd, respectively, harmonics. To illustrate this, Fig. 1 shows this separation of basis functions in the frequency domain. In the figure, the power spectrum of a pure bit “1” sequence is shown for $T=2 \mu\text{s}$ and center frequency of 2.4 GHz. Note, only even harmonics appear.

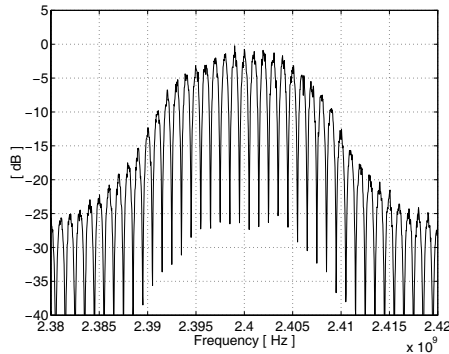

Fig. 1. Power spectrum of an FM-DCSK signal for a pure bit “1” sequence.

The first conclusion is that for bit “1” the weights $W_{j,k}$ in (2) are equal to zero for each odd harmonics since there is no signal energy at those frequencies. The zero weights suppresses the noise components at odd harmonics. Similarly, for bit “0” the weights $W_{j,k}$ are zero for each even harmonics.

To get the exact values of weights, the voltage spectrum of an FM-DCSK signal was determined for a very long FM-DCSK signal carrying an equiprobable random bit sequence. Since an FM-DCSK receiver with the parameters of $2B=30.5 \text{ MHz}$ and $T=2 \mu\text{s}$ is considered in our simulations, only 61 weights may differ from zero as shown in Fig. 2. As examples, the first four values of $W_{j,k}$ are given in Table 1.

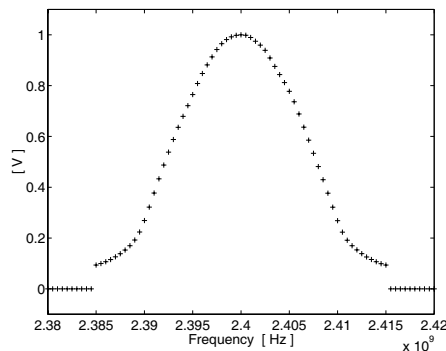

Fig. 2. Voltage spectrum of FM-DCSK signal carrying a random bit sequence.

Table 1. The first four values of the weights $W_{j,k}$.

Frequencies [MHz]	Bit “1”	Bit “0”
	$W_{1,k}$	$W_{2,k}$
2,400.0	1.00	0.00
2,399.5 2,400.5	0.00	0.9983
2,399.0 2,401.0	0.9896	0.00
2,398.5 2,401.5	0.00	0.9748

3.2. Block Diagram of the New FM-DCSK Detector

Consider the reception of bit “1” first. The subspace of $g_1(t)$ contains only the even harmonics of the clock frequency $1/T$. Substituting $j=1$ into (2) we obtain for $g_1(t)$

$$T_C E_{1,m} = \sum_{k=K_1}^{K_2} \left(\left[W_{1,k} \int_0^T \tilde{r}_m(t) \cos(k \frac{2\pi}{T} t) dt \right]^2 + \left[W_{1,k} \int_0^T \tilde{r}_m(t) \sin(k \frac{2\pi}{T} t) dt \right]^2 \right) \quad (3)$$

where $T_C = T/2$, k is an even number and the weights $W_{1,k}$ may be determined from Fig. 2 and Table 1.

In a similar fashion, substituting $j=2$ into (2) we obtain the product of $T_C E_{2,m}$ for bit “0”. In the case of $g_2(t)$, k is an odd number and the values of $W_{2,k}$ may be determined from Fig. 2 and Table 1.

The decision is done in favor of bit “1” if

$$T_C E_{1,m} - T_C E_{2,m} > 0. \quad (4)$$

From (3) and (4), the new FM-DCSK detector may be constructed as shown in Fig. 3. Like the conventional coherent receivers, theoretically there is no need for channel filter in this receiver since the bandlimiting of input signal is performed by the appropriate choice of weights.

4. LIMIT ON BER IMPROVEMENT

The noise performance of optimum noncoherent FM-DCSK detector is shown by dotted curve in Fig. 4. For comparison, the noise performance of frequency domain FM-DCSK [5] (dash-dot curve), differentially coherent FM-DCSK (solid curve) and noncoherent FSK detectors (dashed curve) are also shown.

The frequency domain FM-DCSK and differentially coherent FM-DCSK detectors have the same noise performance. Recall that in the frequency domain FM-DCSK detector the weights in (2) have only two values, 0 and 1, while in the optimum noncoherent FM-DCSK detector the weights are matched to the spectrum of FM-DCSK signal.

From Fig. 4, the following conclusions are drawn. The application of chaotic GML decision rule improves the

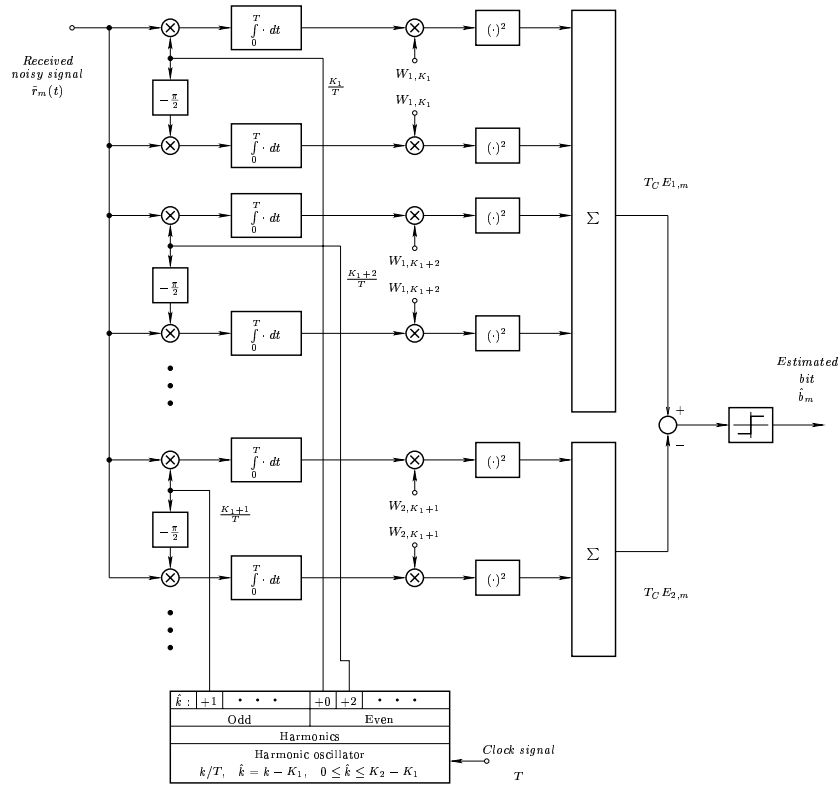

Fig. 3. Block diagram of optimum noncoherent FM-DCSK detector.

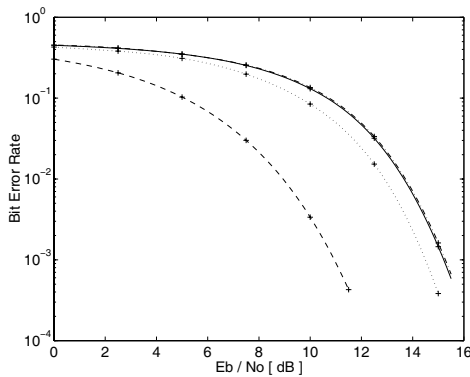

Fig. 4. Noise performance of optimum noncoherent FM-DCSK (dotted curve), frequency domain FM-DCSK (dash-dot curve) and differentially coherent FM-DCSK (solid curve) detector. BER of noncoherent FSK, upper bound on noise performance improvement, is shown by dashed curve.

noise performance since it minimizes the variance of observation signal by matching the weights $W_{j,k}$ to the spectrum of FM-DCSK signal. The noise performance may be improved by reducing the bandwidth of FM-DCSK signal, the lower the bandwidth, the better the noise performance. In the limit, optimum noncoherent FM-DCSK achieves the noise performance of noncoherent FSK.

However, if the signal bandwidth is reduced then FM-DCSK signal becomes a narrow-band signal and the excellent multipath performance of FM-DCSK is lost. The signal bandwidth is one of the most important design parameter, the small bandwidth gives a better noise but worse multipath performance, while increasing the bandwidth results in worse noise but improved multipath performance.

5. REFERENCES

- [1] M. Hasler, G. Mazzini, M. Ogorzalek, R. Rovatti, and G. Setti, "Special issue on applications of nonlinear dynamics to electronic and information engineering," *Proceedings of the IEEE*, vol. 90, no. 5, May 2002.
- [2] G. Kolumbán, M. P. Kennedy, Z. Jákó, and G. Kis, "Chaotic communications with correlator receiver: Theory and performance limit," *Proceedings of the IEEE*, vol. 90, no. 5, pp. 711–732, May 2002.
- [3] L. M. Fink, *Discrete Message Transmission Theory*, Soviet-skaya Radio, Moscow, 2nd edition, 1970, In Russian.
- [4] G. Kolumbán, F. C. M. Lau, and M. Small, "A new description of chaotic waveform communications: The Fourier analyzer approach," in *Proc. ECCTD'03*, Cracow, Poland, September 1-4 2003, vol. III, pp. 241–244.
- [5] G. Kolumbán, "A new frequency-domain FM-DCSK detector," in *Proc. ECCTD'03*, Cracow, Poland, September 1-4 2003, vol. III, pp. 253–256.