

Multiplexing of Fiber Bragg Grating Sensors Using an FMCW Technique

Peter K. C. Chan, W. Jin, *Senior Member, IEEE*, J. M. Gong, and M. S. Demokan, *Senior Member, IEEE*

Abstract—We report on the use of a frequency-domain reflectometry technique for multiplexing fiber Bragg grating (FBG) sensors. This technique is based on the modulation of light intensity from a broadband source by a swept-frequency RF carrier. Signals from the FBG sensors located at different positions in an array are separated in the frequency-domain and demodulated using a tunable optical filter. A three FBG sensor system is experimentally demonstrated. The potential of the technique for multiplexing a large number of FBG sensors is discussed.

Index Terms—Fiber Bragg gratings, frequency division multiplexing, optical fiber sensors.

I. INTRODUCTION

FIBER Bragg Gratings (FBG's) have been identified as very important sensing elements especially for strain measurement in smart structures [1]. In many applications, arrays of FBG sensors are required for multipoint or quasi-distributed measurements; multiplexing of FBG sensors is therefore essential in order to reduce the cost per sensing point and to increase the competitiveness of FBG sensors against conventional electrical sensors.

The most popular technique for multiplexing FBG sensors is the wavelength-division-multiplexing (WDM) technique [2]. The maximum sensor number that can be multiplexed using the WDM technique is determined by the ratio of the source spectral width over the spacing between the Bragg wavelengths of the FBG's. For applications requiring a larger multiplexing gain, a combination of WDM and time-division-multiplexing (TDM) and/or spatial-division-multiplexing (SDM) techniques may be used.

A code-division multiple-access (CDMA) scheme has recently been demonstrated for dense wavelength division multiplexing of FBG sensors [3]. The CDMA technique has the advantage of larger average sensor output power over the TDM technique and consequently better signal to noise ratio. Although a two sensor array was demonstrated experimentally with a channel isolation (crosstalk) of >20 dB, a larger number (>100) of sensor and a better channel isolation is expected by increasing the code sequence length.

In this letter, we report on the multiplexing of FBG sensors using a frequency modulated continuous wave (FMCW) approach [4], [5]. The FMCW technique provides a similar

Manuscript received June 14, 1999; revised July 26, 1999. This work was supported by the Hong Kong Polytechnic University Research Grants (Project V390 and Project S611).

The authors are with the Department of Electrical Engineering, The Hong Kong Polytechnic University, Hung Hom, Kowloon, Hong Kong.

Publisher Item Identifier S 1041-1135(99)08707-8.

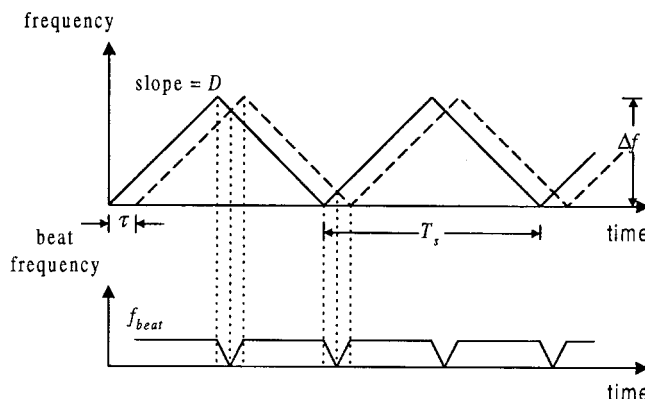

Fig. 1. Production of beat note.

average power level at the photo detector but possible lower cost compared with the CDMA approach because the FMCW technique uses simpler electronic processing circuitry.

II. PRINCIPLE OF OPERATION

Fig. 1 shows the concept of FMCW technique where a triangular frequency sweeping is assumed. A time difference between a triangular frequency-swept reference waveform and a signal (a delayed version of the reference) produce a difference frequency (beat frequency f_{beat}) that is equal to the product of the rate of frequency excursion D and the time delay difference τ between two waves; i.e., $f_{beat} = D\tau = (2\Delta f f_s)\tau$ [4]. Here Δf is the frequency excursion; $f_s = 1/T_s$, T_s is the period of the triangular sweeping. The resultant output beat note has a line spectrum at intervals of f_s . The position of the peak in the envelope of the line spectrum gives the beat frequency f_{beat} [5].

The detailed spectral characteristics of the beat note for a particular set of parameters (i.e., $\Delta f = 40$ MHz, $f_s = 5$ kHz) have been studied by means of computer simulation. These parameters are the approximate values used in our experiments. It was found that, for small τ (e.g., $\tau < 400$ ns), the beat note spectrum is essentially a single line if the beat frequency coincides with one of the harmonics of the sweeping signal, i.e., $f_{beat} = D\tau = 2f_s\Delta f\tau = mf_s$, or $2\Delta f\tau = m$, where m is an integer. The simulation results suggest that the magnitudes of the sidelines are -48 dB below that of the central line. If N sensors are to be multiplexed with their respective time delay difference τ_m ($m = 1, 2, \dots, N$) chosen in such a way so that the respectively beat frequencies satisfying condition f_{beat_i} ($m = 1, 2, \dots, N$), the cross

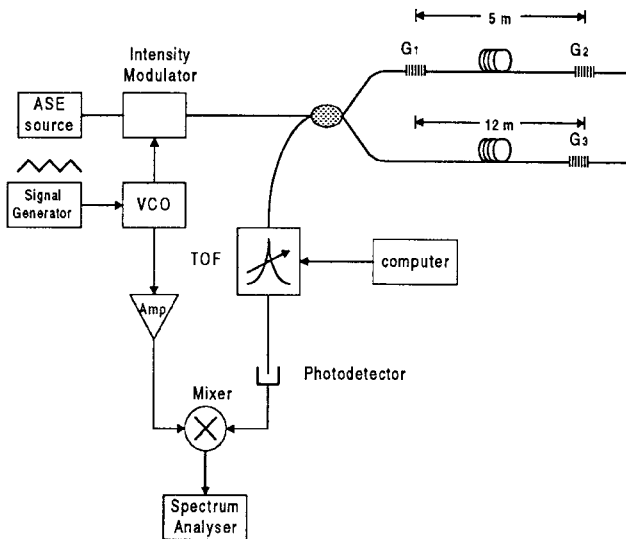

Fig. 2. Experimental setup.

talk (determined by the magnitude of the spectral sidelines) between any two of the sensors should be below -48 dB. The number of sensors that can be multiplexed is $400/12.5 = 32$. When combined with the WDM technique, the FMCW technique should be capable of potentially multiplexing a few hundreds of FBG's with the exact number to be determined by the ratio of the source spectral width over the sensor dynamic range. The aforementioned condition requires an equal time delay difference between adjacent sensors of 12.5 ns or a physical separation of 1.25 m between adjacent FBG's. The magnitude of the side lines and hence the cross talk level would increase if the physical separation is biased from the optimal value, i.e., 1.25 m.

Fig. 2 shows an example of a three-sensor array using the FMCW technique. Light from a broadband source is modulated with a triangular swept frequency carrier generated from a voltage controlled oscillator (VCO) and launched into the FBG sensor array. The reflected signals from FBG's are guided back to a tunable optical filter (TOF), then a photodetector, and mixed with a reference signal from the VCO subsequently. The system output will consist of a number of beat notes with their beat frequencies determined by the delay differences between the FBG sensor signals and the reference signal. The magnitudes of the beat signals are proportional to the convolution of the individual grating reflection spectrum and the transmission spectrum of the tunable filter. The Bragg wavelength of the individual FBG's can be interrogated by scanning the TOF and record the control voltage of the TOF that corresponds to the peak of the different frequency components.

III. EXPERIMENTS AND RESULTS

Experiments were conducted using the system shown in Fig. 2. Light from an Er-doped fiber ASE source was modulated in intensity through a VCO driven integrated optic modulator by a triangular frequency-swept carrier from about 58 – 99 MHz with 5 -kHz repetition rate. The TOF used was made by JDS with linewidth 0.37 nm and a voltage-tuning

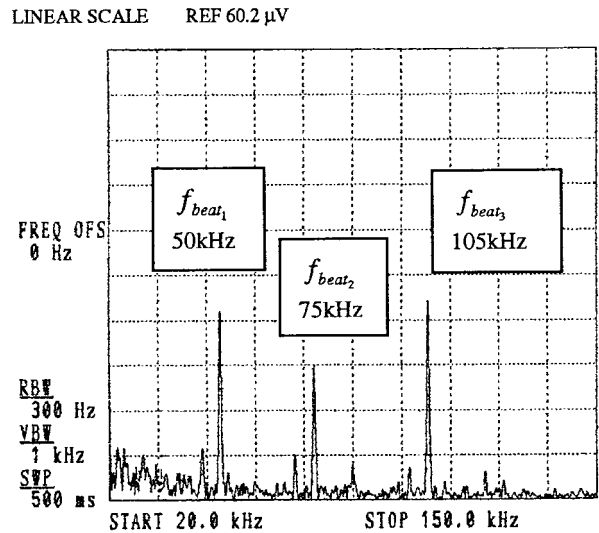

Fig. 3. Beat-note spectrum of the three sensor array.

coefficient of 2.95 nm/V. All FBG's were manufactured in our laboratory by using the same phase-mask of nominal Bragg wavelength of 1545.61 nm. The spectral widths of the FBG's are 0.17 nm. The reflectivity of grating G_1, G_2 , and G_3 are approximately $40, 100$, and 40% , respectively. The spatial separations between G_1 and G_2 and between G_1 and G_3 were arbitrarily chosen to be around 5 and 12 m, respectively. No effort was made to control the OPD between sensors to match the beat frequencies to the harmonics of the frequency-sweeping. The electrical signal produced by the photodetector was mixed with the reference signal from the VCO. The beat signals generated from the mixer were observed from an electrical spectrum analyzer. Fig. 3 shows a typical display of the spectrum analyzer. The three major peaks at 50 kHz ($10f_s$), 75 kHz ($15f_s$), and 105 kHz ($21f_s$) correspond to sensor G_1, G_2 , and G_3 , respectively.

The sensor system was used for strain measurements. During the measurements, the three FBG sensors were strained independently by translation stages and the TOF was controlled through a computer by applying a slow varying voltage, via a 14 -bit D/A converter. The system has a minimum resolvable wavelength shift of approximately 1.8 pm corresponding to $1.5 \mu\epsilon$ applied strain. To demonstrate that this technique can be used to multiplex FBG sensors with the same Bragg wavelength, grating G_1 was shifted to 1546.29 nm and used as a reference grating. The amplitude of the beat frequencies from G_2 and G_3 (at 75 and 105 kHz) were monitored while gratings G_2 and G_3 were being strained from 0 – $1500 \mu\epsilon$. The measurements were repeated 10 times for each applied strain and an average was taken as the TOF control voltage. Fig. 4 shows the relations between the measured control voltages of the tunable filter and the applied strains to G_2 and G_3 . The measured control voltage corresponding to the peak of the beat signal at 105 kHz has a very good linear relation with the strain applied to G_3 (lower diagram) with root-mean-square (rms) strain error of $2.1 \mu\epsilon$. However, the measured voltage corresponding to the peak of the beat signal at 75 kHz shows some nonlinearity when the strain applied to G_2

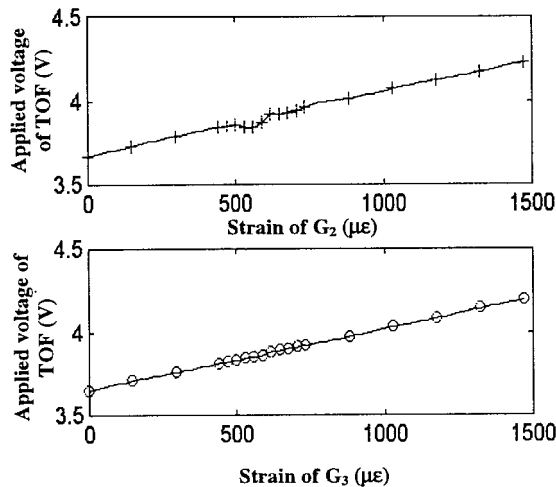

Fig. 4. Applied voltage of TOF as function of the strain applied to grating G_2 (upper diagram) and G_3 (lower diagram).

was around $550 \mu\epsilon$ (upper diagram). This corresponds to the spectral overlapping of G_1 and G_2 and the maximum bias from the linear relation was approximately 0.04 V corresponding to $100 \mu\epsilon$. This value agrees well with the crosstalk level estimated from the “spectral-shadowing” effect [1]. This effect can be reduced using low reflectivity gratings. To estimate the contribution from the nonzero sidelines, gratings G_2 and G_3 were tuned by applying strain so that only light reflected by grating G_1 was allowed to pass through the tunable filter. The magnitudes of the sidelines at 75 and 105 kHz were found to be below the noise floor. Simulations were done for various values of OPD to match the simulated spectrum to that of G_1 as shown in Fig. 3. The difference between the actual and the optimal separation was found to be about 17 cm. The magnitudes of the sidelines at 75 and 105 kHz were estimated to be -20 and -28 dB below that of the central line at 50 kHz. These correspond to a maximum crosstalk level of less than $10 \mu\epsilon$ [6]. For other strain values where the spectra of G_1 and G_2 are not overlapping, the strain resolution in terms of rms value of the strain is calculated to be less than $1.8 \mu\epsilon$.

To demonstrate the feasibility of obtaining a single line spectrum by matching the beat frequency to a harmonic of the repetition frequency, gratings G_1 and G_3 were tuned by the

application of strain so that only the spectrum corresponding to G_2 can be observed. An Er-doped fiber amplifier (EDFA) was inserted just before the photodetector to enhance the signal to noise ratio. By fine tuning the frequency excursion (i.e., by changing Δf) to match the maximum of the beat note envelope to one of the harmonics, a single line spectrum at 85 kHz ($17f_s$) was obtained. The shift in the beat frequency from 75 to 85 kHz is caused by the extra delay introduced by the EDFA. The magnitudes of sidelines were 30 dB below the central line indicating that crosstalk level between sensors should be below -30 dB . This is 10 dB better than that demonstrated by the CDMA approach [3] and would cause a strain measurement error in the worst case of less than $10 \mu\epsilon$ [6]. The discrepancy between the experimental value (-30 dB) and the theoretical prediction (-48 dB) is believed caused by the nonideal response of the VCO used in our experiments. We expect that the sideline suppression can be improved if a VCO with a constant output voltage over the operating frequency range is used.

IV. SUMMARY

In conclusion, we have demonstrated a FMCW based multiplexing technique for addressing FBG sensor arrays. This technique can be used to multiplex FBG sensors with the same Bragg wavelengths. When coupled with WDM approach, the technique has the potential to multiplex a few hundreds of FBG sensors with $\mu\epsilon$ resolution.

REFERENCES

- [1] A. D. Kersey, M. A. Davis, H. J. Patrick, M. LeBlanc, K. P. Koo, C. G. Askins, M. A. Putnam, and E. J. Friebele, “Fiber grating sensors,” *J. Lightwave Technol.*, vol. 15, pp. 1442–1463, Aug. 1997.
- [2] R. L. Idriss, M. B. Kodindouma, A. D. Kersey, and M. A. Davis, “Multiplexing Bragg grating optical fiber sensors for damage evaluation in highway bridges,” *Smart Mater. Struct.*, vol. 7, pp. 209–216, 1998.
- [3] K. P. Koo, A. B. Tveten, and S. T. Vohra, “Dense wavelength division multiplexing of fiber Bragg grating sensors using CDMA,” *Electron. Lett.*, vol. 35, pp. 165–167, 1999.
- [4] B. R. Mahafza, *Introduction to Radar Analysis*. Orlando, FL: CRC Press, 1998.
- [5] A. J. Hymans and J. Lait, “Analysis of a frequency-modulated continuous-wave ranging system,” *Proc. Inst. Elect. Eng.*, vol. 107B, pp. 365–372, July 1960.
- [6] W. Jin, “Investigation of interferometric noise in fiber-optic Bragg grating sensors by use of tunable laser sources,” *Appl. Opt.*, vol. 37, no. 13, pp. 2517–2525, May 1998.